

USER'S MANUAL
Of
AMD 770/780G/780V & AMD SB700
Based
M/B For Socket AM2+/AM2 Quad Core
AMD Processor

NO. G03-XBLUE77A3-F

Rev: 1.0

Release date: March, 2009

Trademark:

* Specifications and information contained in this documentation are furnished for information use only, and are subject to change at any time without notice, and should not be construed as a commitment by manufacturer.

Environmental Protection Announcement

Do not dispose this electronic device into the trash while discarding. To minimize pollution and ensure environment protection of mother earth, please recycle.



TABLE OF CONTENT

USER'S NOTICE.....	iii
MANUAL REVISION INFORMATION	iii
COOLING SOLUTIONS.....	iii
CHAPTER 1 INTRODUCTION OF AMD 770/780V/780G MOTHERBOARDS	
1-1 FEATURES OF MOTHERBOARD	1
1-1.1 SPECIAL FEATURES OF MOTHERBOARD.....	2
1-2 SPECIFICATION.....	3
1-3 PERFORMANCE LIST	4
1-4 LAYOUT DIAGRAM & JUMPER SETTING	5
CHAPTER 2 HARDWARE INSTALLATION	
2-1 HARDWARE INSTALLATION STEPS.....	8
2-2 CHECKING MOTHERBOARD'S JUMPER SETTING	8
2-3 INSTALL CPU.....	9
2-3-1 GLOSSARY.....	9
2-3-2 ABOUT AMD Athlon64 Socket AM2	10
2-4 INSTALL MEMORY	11
2-5 EXPANSION CARDS	12
2-5-1 PROCEDURE FOR EXPANSION CARD INSTALLATION	12
2-5-2 ASSIGNING IRQS FOR EXPANSION CARD.....	12
2-5-3 PCI-EXPRESS2.0 SLOT	13
2-6 CONNECTORS, HEADERS	14
2-6-1 CONNECTORS.....	14
2-6-2 HEADERS	17
2-7 STARTING UP YOUR COMPUTER	21
CHAPTER 3 INTRODUCING BIOS	
3-1 ENTERING SETUP	22
3-2 GETTING HELP	22
3-3 THE MAIN MENU.....	23
3-4 STANDARD BIOS FEATURES.....	25
3-5 ADVANCED BIOS FEATURES.....	26
3-5-1 CPU CONFIGURATION.....	28
3-6 ADVANCED CHIPSET FEATURES	29
3-6-1 MEMORY CONFIGURATION	29
3-6-2 INTERNAL GRAPHICS CONFIGURATION	31
3-6-3 PCI EXPRESS CONFIGURATION	31
3-7 INTEGRATED PERIPHERALS	32
3-7-1 ONBOARD SATA DEVICE	32
3-7-2 ONBOARD DEVICE CONTROL.....	33
3-7-3 SUPER IO CONFIGURATION	34
3-8 POWER MANAGEMENT SETUP	35
3-9 MISCELLANEOUS CONTROL	36
3-10 HARDWARE HEALTH CONFIGURE/PC HEALTH STATUS.....	37
3-11 CPU THERMAL THROTTLING OPTIONS.....	38
3-12 POWER USER OVERCLOCK SETTING.....	39
3-13 BIOS SECURITY FEATURE/PASSWORD SETTINGS	40
3-14 LOAD OPTIMAL/FAILSAFE/STANDARD DEFAULTS	41
3-15 SAVE CHNGES AND EXIT/DISCARD AND EXIT	42
CHAPTER 4 DRIVER & FREE PROGRAM INSTALLATION	
MAGIC INSTALL SUPPORTS WINDOWS2000/XP/VISTA	43
4-1 ATI INSTALL ATI DRIVER PACK.....	44
4-2 SOUND INSTALL AL662 HD CODEC AUDIO DRIVER	45
4-3 LAN INSTALL REALTEK LAN CONTROLLER DRIVER	46
4-4 WIFI_N INSTALL RT2770 WIRELESS NETWORK	46
4-5 WIFI_BG INSTALL RTL8187 WIRELESS NETWORK.....	47
4-6 RAID INSTALL SATA RAID DRIVER AND UTILITY	48
4-7 NORTON INSTALL NORTON 2009 ANTI-VIRUS PROGRAM.....	48
4-8 PC-HEALTH INSTALL MYGUARD HARDWARE MONITOR UTILITY	49
4-9 HOW TO UPDATE BIOS.....	49
4-10 AMD PLATFORM RAID FUNCTION INSTALLATION	50
4-11 PRO MAGIC PLUS FUNCTION INSRUCTION	53
4-12 G.P.I.FUNCTION INSTALLATION STEP.....	54
4-13 G.P.I. LED DISPLAY	57
APPENDIX	58



Safety Environmental Instruction

- Avoid the dusty, humidity and temperature extremes. Do not place the product in any area where it may become wet.
- 0 to 40 centigrade is the suitable temperature. (The figure comes from the request of the main chipset)
- Generally speaking, dramatic changes in temperature may lead to contact malfunction and crackles due to constant thermal expansion and contraction from the welding spots' that connect components and PCB. Computer should go through an adaptive phase before it boots when it is moved from a cold environment to a warmer one to avoid condensation phenomenon. These water drops attached on PCB or the surface of the components can bring about phenomena as minor as computer instability resulted from corrosion and oxidation from components and PCB or as major as short circuit that can burn the components. Suggest starting the computer until the temperature goes up.
- The increasing temperature of the capacitor may decrease the life of computer. Using the close case may decrease the life of other device because the higher temperature in the inner of the case.
- Attention to the heat sink when you over-clocking. The higher temperature may decrease the life of the device and burned the capacitor.

USER'S NOTICE

COPYRIGHT OF THIS MANUAL BELONGS TO THE MANUFACTURER. NO PART OF THIS MANUAL, INCLUDING THE PRODUCTS AND SOFTWARE DESCRIBED IN IT MAY BE REPRODUCED, TRANSMITTED OR TRANSLATED INTO ANY LANGUAGE IN ANY FORM OR BY ANY MEANS WITHOUT WRITTEN PERMISSION OF THE MANUFACTURER.

THIS MANUAL CONTAINS ALL INFORMATION REQUIRED TO USE [AMD 770/780V/780G](#) MOTHERBOARD AND WE DO ASSURE THIS MANUAL MEETS USER'S REQUIREMENT BUT WILL CHANGE, CORRECT ANY TIME WITHOUT NOTICE. MANUFACTURER PROVIDES THIS MANUAL "AS IS" WITHOUT WARRANTY OF ANY KIND, AND WILL NOT BE LIABLE FOR ANY INDIRECT, SPECIAL, INCIDENTAL OR CONSEQUENTIAL DAMAGES (INCLUDING DAMAGES FOR LOSS OF PROFIT, LOSS OF BUSINESS, LOSS OF USE OF DATA, INTERRUPTION OF BUSINESS AND THE LIKE).

PRODUCTS AND CORPORATE NAMES APPEARING IN THIS MANUAL MAY OR MAY NOT BE REGISTERED TRADEMARKS OR COPYRIGHTS OF THEIR RESPECTIVE COMPANIES, AND THEY ARE USED ONLY FOR IDENTIFICATION OR EXPLANATION AND TO THE OWNER'S BENEFIT, WITHOUT INTENT TO INFRINGE.

Manual Revision Information

Reversion	Revision History	Date
1.0	First Edition	March., 2009

Item Checklist

- AMD 780G Chipset based motherboard
- AMD 780G Chipset motherboard User's Manual
- DVD for Motherboard Utilities
- I/O Back Panel Shield
- SATA Cable
- HDD Cable

AMD Processor Family Cooling Solutions

As processor technology pushes to faster speeds and higher performance with increasing operation clock, thermal management becomes increasingly crucial while building computer systems. Maintaining the proper computing environment without thermal increasing is the key to reliable, stable, and 24 hours system operation. The overall goal is keeping the processor below its specified maximum case temperature. Heatsinks induce improved processor heat dissipation through increasing surface area and concentrated airflow from attached active cooling fans. In addition, interface materials allow effective transfers of heat from the processor to the heatsink. For optimum heat transfer, AMD recommends the use of thermal grease and mounting clips to attach the heatsink to the processor.

Please refer to the website below for collection of heatsinks evaluated and recommended for Socket AM2+ processors by AMD. In addition, this collection is not intended to be a comprehensive listing of all heatsinks that support [Socket-AM2/AM2+/AM3](#) processors.

Chapter 1

Introduction of AMD 770/ 780V/780G Motherboards

1-1 Features of motherboard

The AMD 770/780V/780G chipset motherboard series are based on the latest AMD 770/780V/780G Chipset and the SB700 chipset which supports the innovative 64-bit AMD AM3 Phenom™ II X3 processor and AMD Phenom™ II X4 processors ; dual core and quad core AMD Phenom™ processors ; Athlon64 X2 processors and Sempron Processors. With an integrated low-latency high-bandwidth DDRII and DDRIII memory controller and a highly-scalable Hyper Transport technology-based system bus up to HT 3.0. AMD770/780V/780G Platform Processor Chipset motherboard series deliver the outstanding system performance and professional desktop platform solution processors.

The AMD770/780V/780G Series motherboards support new generation Socket AM3/AM2+/AM2 processors with an integrated DDRII memory controller for dual channel DDRII533 /DDRII667 /DDRII800/DDRII 1066 (AM2 Sempron processors only support up to DDRII667 memory) DDRII modules up to 4GB, and DDRIII memory controller for dual channel DDRIII 1066/DDRIII 1333 modules up to 4GB. The motherboard is embedded with SB 700 chipset of providing 1 ULTRA ATA 133 connector and Serial ATA2 with RAID 0, 1, 10, JBOD functions which support up to two IDE hard disk drive devices and six Serial ATA2 devices to accelerate hard disk drives and guarantee the data security without failure in advanced computing performance.

The AMD 770/780V/780G motherboards provide 10/100/1000 LAN function with RealTek RTL8111CVC PCI-E Gigabit LAN which supports optional 10/100/1000Mbps data transfer rate. And the embedded HD 6-channel ALC662 HD Audio CODEC is fully compatible with Sound Blaster Pro standards that offer you with the home cinema quality and satisfying software compatibility.

The AMD 770/780V/780G Series motherboards deliver outstanding value and performance for gamers, with a true bandwidth design for Multi-GPU configurations. This high bandwidth architecture in the AMD 770/780V/780G chipset is combined with the flexibility for single or dual card configurations.

This motherboard series offers one PCI-Express2.0 x16 By 16-lane graphics slot, one PCI-Express2.0 x16 By 4-lane graphics slots and one PCI-Express2.0 x1 graphics slot for astonishing performance with brilliant and intense 3D graphics The motherboard also carries two 32-bit PCI slots guarantee the rich connectivity for the I/O peripheral devices.

Embedded USB controllers as well as capability of expanding to 8 of USB2.0 functional ports delivering 480Mb/s bandwidth of rich connectivity, these motherboards meet the future USB demands which are also equipped with hardware monitor function on system to monitor and protect your system and maintain your non-stop business computing.

Some special features--- **CPU Thermal Throttling/ CPU VID /DIY Clear Button/ OC-CON /G.P.I Function/WI-FI Header** in this motherboard are designed for power user to use the over-clocking function in more flexible ways. But please be caution that the over-clocking maybe causes the fails in system reliabilities. This motherboard provides the guaranteed performance and meets the demands of the next generation computing. But if you insist to gain more system performance with variety possibilities of the components you choose, please be careful and make sure to read the detailed descriptions of these value added product features, please get them in the coming section.

1-1.1 Special Features of Motherboard

CPU Thermal Throttling Technology--- (The CPU Overheat Protection Technology)

To prevent the increasing heat from damage of CPU or accidental shutdown while at high workload, the CPU Thermal Throttling Technology will force CPU to enter partially idle mode from 87.5% to 12.5% according to preset CPU operating temperature in BIOS (from 40 °C to 90°C). When the system senses the CPU operating temperature reaching the preset value, the CPU operating bandwidth will be decreased to the preset idle percentage to cool down the processor. When at throttling mode the beeper sound can be optionally selected to indicate it is in working. (For detail operating please read Section 3-11 Bi-turbo Configuration)

CPU VID--- (Shift to Higher Performance)

The CPU voltage can be adjusted for the precisely over-clocking of extra demanding computing performance.

DIY Clear

The CMOS button is to facilitate the clear CMOS process for power user overclocking function. The user can easily clear or restore CMOS setting by pressing the button without tacking trouble to remove the case and locate the jumper for clear CMOS .

OC-CON --- (High-polymer Solid Electrolysis Aluminum Capacitors)

The working temperature is from 55 degrees Centigrade below zero to 125 degrees Centigrade, OC-CON capacitors possess superior physical characteristics that can be while reducing the working temperature between 20 degrees Centigrade each time, intact extension 10 times of effective product operation lives, at not rising degrees Centigrade of working temperatures each time a relative one, life of product decline 10% only too.

G.P.I Function---(Green power indicator function)

The full name of G.P.I technology is Green Power Indicator technology, obviously technology utilized to low power consumption. G.P.I is a technology with remarkable power saving function:

WI-FI Technology

WI-FI--Full name is wireless Fidelity. It has been used in notebook, mobile phone, PDA, digital cameras and Mobile Terminals widely. With WI-FI. We do not need to worry about the speed and high spending when we are dialing long-distance calls, browsing web pages, receiving and sending E-mails, loading music, delivering digital photos.

1-2 Specification

Spec	Description
Design	* ATX form factor 4 layers PCB size: 29.5cm x21.5cm
Chipset	* AMD 770/780V/780G North Bridge Chipset * AMD SB 700 South Bridge Chipset
CPU Socket AM2	* Support 64bit AMD Socket AM2/AM2+AM3 processor utilizing Flip-Chip Pin Grid Array package * Support for AMD Athlon64 940-pin Dual –Core Athlon 64x2 processor, Athlon 64 & Sempron Processors with HTT Frequency 1GHz and the latest AMD Phenom™ FX, quad core AMD Phenom™ processors with HTT 3.0. * Ready for AM3 CPU
Memory Socket	* 240-pin DDRII Module socket x 2 * 240-pin DDRIII Module socket x 2 * Support 2pcs DDRII533/DDRII667/DDRII800/DDRII1066 Modules Expandable to 4GB or 2pcs DDRIII 1066/DDRIII 1333 Modules Expandable to 4GB * Dual channel supported
Expansion Slot	* PCI-Express2.0 x16 by 16 Lane 1pcs * PCI-Express2.0 x16 by 4 Lane 1pcs * PCI-Express2.0 x1 slot 1pcs * 32-bit PCI slot x 2pcs
Integrate IDE and Serial ATA2 RAID	* One IDE controllers support PCI Bus Mastering, ATA PIO/DMA and the ULTRA DMA 33/66/100/133 functions that deliver the data transfer rate up to 133 MB/s for 2 IDE Devices and for 6 Serial ATA2 ports providing 300 MB/sec data transfer rate with RAID 0, 1, 10 and JBOD functions
Gigabit LAN	* Integrated RealTek RTL8111CVC PCI-E Gigabit LAN. * Support Fast Ethernet LAN function of providing 10Mb/100Mb/1000 Mb/s data transfer rate
6 CH-Audio	* Realtek ALC662 HD 6-channel Audio Codec integrated * Audio driver and utility included
BIOS	* AMI 8MB Flash ROM BIOS
Multi I/O	* PS/2 keyboard and PS/2 mouse connectors * HDMI Connector x1 (Optional) * VGA Connector x1 (Optional) * DVI Connector x1 (Optional) * USB2.0 port x 4 and headers x 2 * RJ-45 LAN Connector x1 * Audio connector x1 (Line-in, Line-out, MIC/6CH Audio) * Floppy disk drive connector x1/ Hard disk drive connector x1 * Serial Port Header x1 * HDMI_SPDIF header x1/ IR Connector x1 * WI-FI Header x1

1-3 Performance List

The following performance data list is the testing result of some popular benchmark testing programs. These data are just referred by users, and there is no responsibility for different testing data values gotten by users (the different Hardware & Software configuration will result in different benchmark testing results.)

Performance Test Report

CPU: AMD Phenom 8600/Athlon 64x2 5400+

DRAM: Kingxon 1G 800X2 Memory

VGA Card : 1. Hybrid CrossFire 2. HD 2400

Hard Disk Driver: Sumsung 160GB

BIOS: To1

OS: Windows XP Professional (SERVICE PACK 2)

3D Mark 2001SE		14141
3D Mark 2003		4685
3D Mark 2005		3418
3D Mark 2006		2624
PCMark2005		
System / CPU / Memory		NA/6077/4302
Graph / HDD		2409/5277
Content Creation Winstone 2004		37.3
Winbench 99 V2.0:		
Business/Hi-end GraphicWinmark99		29100
Business/Hi-end Graphic Winmark		
SISMark 2004: SISMark Rating(Internet Content Creation / Office Productivity)		
SISMark 2007		338
3D Creation/2D Creation		300/411
Web publication		312
Communication/ Document Creation		177/237
Data Analysis		171
SISOFT Sandra 2004 : 1.CPU Arithmetic Benchmark 2.Memory bandwidth Benchmark 3.CPU Multi-Media Benchmark		
1.Dhrystone ALU	MIPS	19590/16546
Whetstone FPU iSSE2	FLOPS	
2.Int/Float Buffered iSSE2	MB/S	50842/56034
3.Integer/Floating-Point	IT/S	5126/5139
UT2003 Benchmark (flyby/botmatch)		171.427/81.560
Quake3 DEMO1 /DEMO2	FPS	342.3/326.3
Return to Castle Wolfenstein	FPS	
Super Pi (1M)	Second	35.594/2m56.688
CPUZ	System / CPU Clock	

1-4 Layout Diagram

XBLUE-77A3

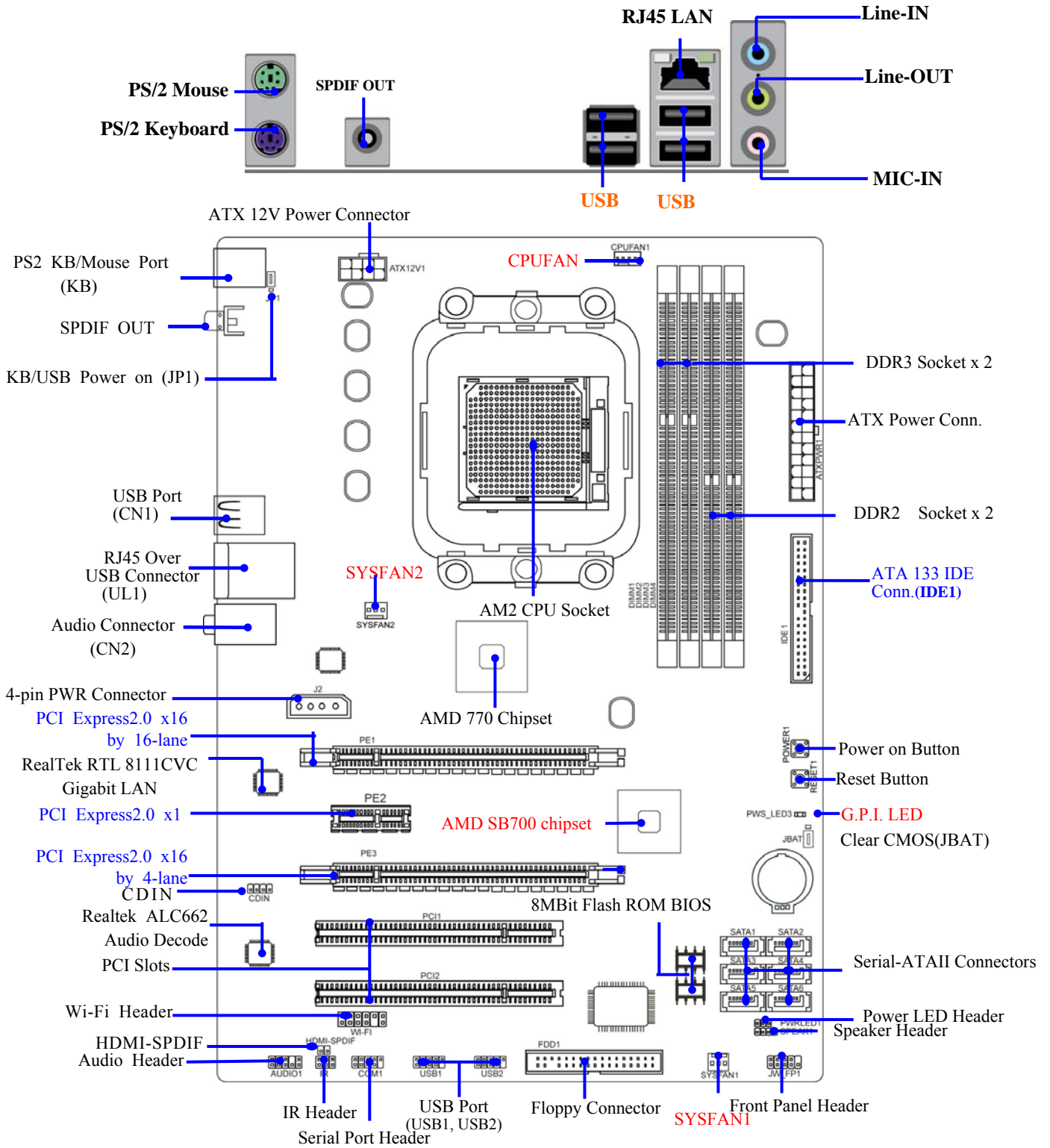

XBlue-78GA3/XBLUE-78VA3 I/O

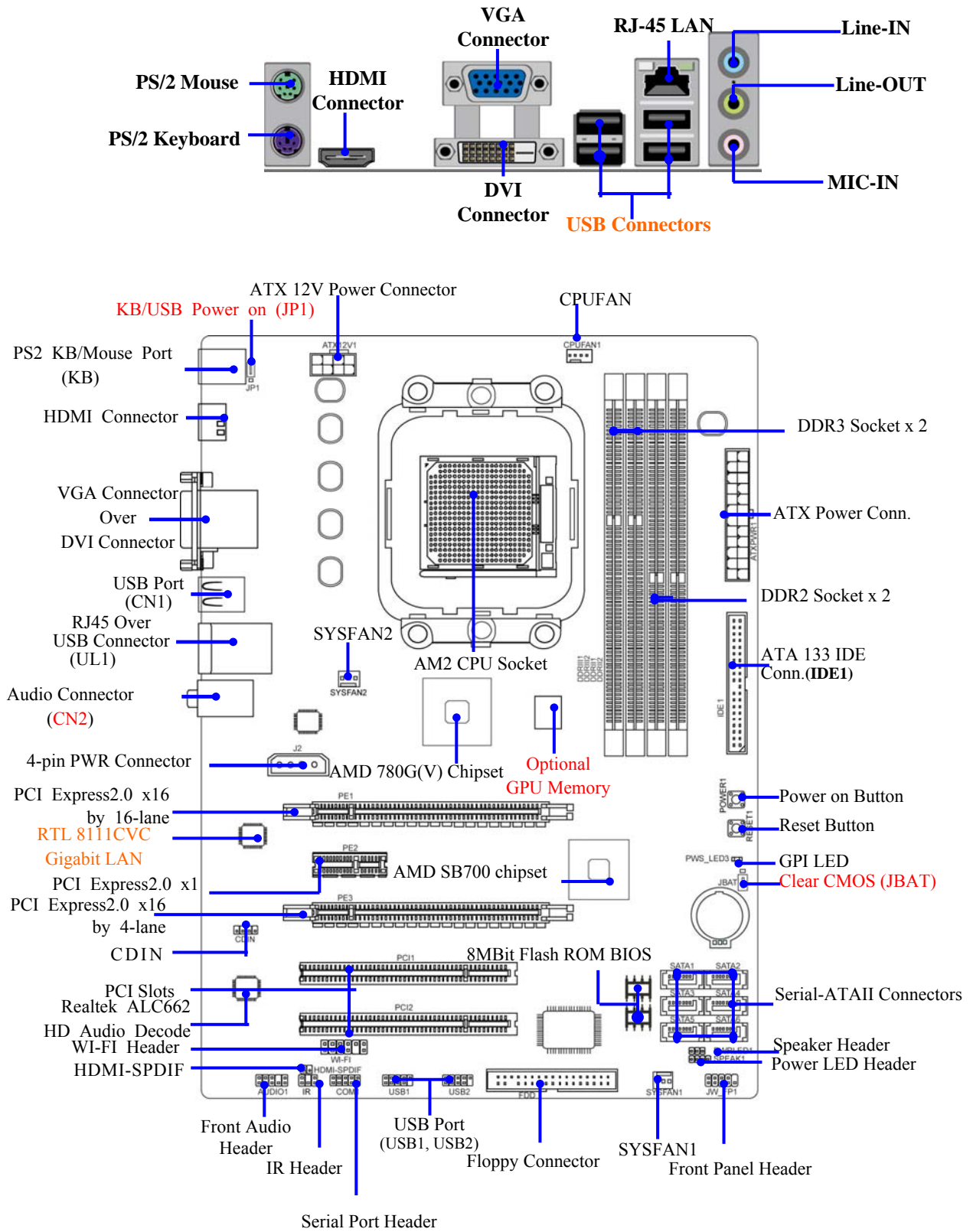

Jumpers

Jumper	Name	Description	Page
JP1	Keyboard/USB Power On Enabled/Disabled	3-pin Block	P.8
JBAT	CMOS RAM Clear	3-pin Block	P.8

Connectors

Connector	Name	Description	Page
ATXPWR1	ATX Power Connector	24-pin Block	P.14
ATX12V1	ATX 12V Power Connector	8-pin Block	P.14
KB	PS/2 Mouse & PS/2 Keyboard Connector	6-pin Female	P.15
USB from CN1, UL1	USB2.0 Port Connector	4-pin Connector	P.15
RJ45LAN from UL1	Gigabit LAN Port Connector	RJ-45 Connector	P.15
J2	CrossFire Power Connector	4-Pin Block	P.15
AUDIO : CN2	6-CH HD Audio Connector	3- phone jack Conn.	P.15
FDD1	Floppy Driver Connector	34-pin Block	P.16
IDE1	Primary/Secondary IDE Connector	40-pin Block	P.16
SATA1~SATA6	Serial ATAII IDE Connectors	7-pin Connector	P.16
VGA	VGA Connector	15-pin Connector	P.17
DVI	DVI Connector	29-pin Connector	P.17
HDMI	HDMI Connector	19-pin Connector	P.17
SPDIF_OUT1	Coaxial SPDIF_OUT Connector	1-phone Connector	P.17

Headers

Header	Name	Description	Page
AUDIO1	SPEAKER, MIC header	9-pin Block	P.17
USB1, USB2	USB Port Headers	9-pin Block	P.18
SPEAK1	PC Speaker connector	4-pin Block	P.18
PWR_LED1	Power LED	3-pin Block	P.18
JW_FP1 (Reset/HDLED/Power Button/PWR_LED)	Front Panel Header (including IDE activity LED/Reset switch / Power On Button lead)	9-pin Block	P.18
SYSFAN1/2	FAN Headers	3-pin Block	P.19
CPUFAN	FAN Header	4-pin Block	P.19
CDIN1	CD Audio-In Header	4-pin Block	P.19
IR	IR infrared module Headers	5-pin Block	P.19
COM1	Serial Port Connector	9-pin Block	P.20
HDMI_SPDIF	SPDIF Out header	2-pin Block	P.20
WI-FI1	Wi-Fi header	11-pin Block	P.20

Expansion Sockets

Socket/Slot	Name	Description	Page
ZIF Socket AM2	CPU Socket	940-pin mPGA Athlon64 CPU Socket	P.10
DDR11~2	DDRII Module Socket	240-pin DDRII Module Socket	P.10
DDR111~2	DDRIII Module Socket	240-pin DDRII Module Socket	P.13
PCI1~PCI2	PCI Slots	32-bit PCI Local Bus Expansion slots	P.13
PE2	PCI-Express2.0 x1Slot	PCI-Express2.0 x1 Expansion Slots	P.13
PE1, PE3	PCI-Express2.0 x16 Slot	PCI-Express2.0 x16 Expansion Slots	P.13

Chapter 2

Hardware Installation

WARNING! Turn off your power when adding or removing expansion cards or other system components. Failure to do so may cause severe damage to both your motherboard and expansion cards.

2-1 Hardware installation Steps

Before using your computer, you had better complete the following steps:

1. Check motherboard jumper setting
2. Install CPU and Fan
3. Install System Memory (DIMM)
4. Install Expansion cards
5. Connect IDE and Front Panel /Back Panel cable
6. Connect ATX Power cable
7. Power-On and Load Standard Default
8. Reboot
9. Install Operating System
10. Install Driver and Utility

2-2 Checking Motherboard's Jumper Setting

(1) **Keyboard/USB function Enabled/Disabled: JP1**

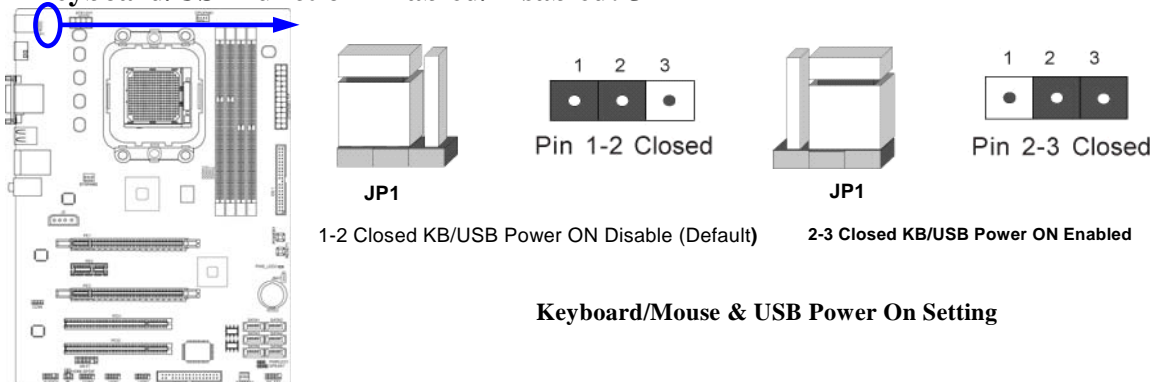

(2) **CMOS RAM Clear (3-pin) : JBAT**

A battery must be used to retain the motherboard configuration in CMOS RAM short 1-2 pins of JBAT to store the CMOS data.

To clear the CMOS, follow the procedure below:

1. Turn off the system and unplug the AC power
2. Remove ATX power cable from ATX power connector
3. Locate JBAT and short pins 2-3 for a few seconds
4. Return JBAT to its normal setting by shorting pins 1-2
5. Connect ATX power cable back to ATX power connector

Note: When should clear CMOS

1. Troubleshooting

2. *Forget password*
3. *After over clocking system boot fail*

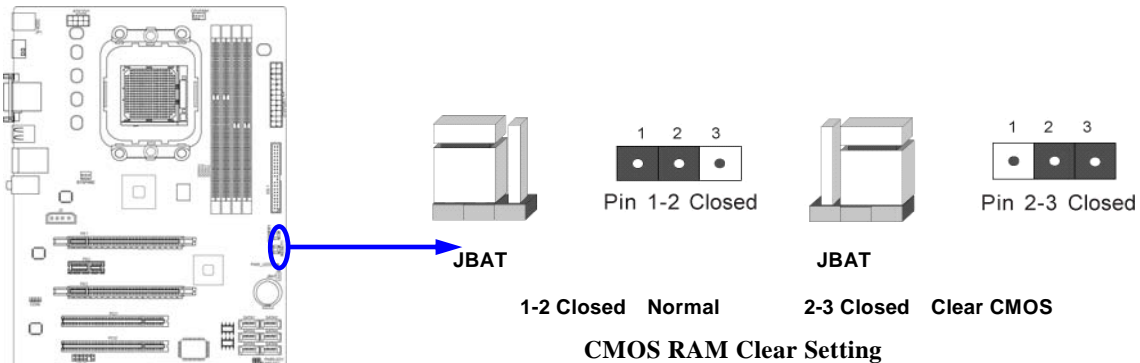

2-3 Install CPU

2-3-1 Glossary

Chipset (or core logic) - two or more integrated circuits which control the interfaces between the system processor, RAM, I/O devices, and adapter cards.

Processor slot/socket - the slot or socket used to mount the system processor on the motherboard.

Slot (PCI-E, PCI, RAM) - the slots used to mount adapter cards and system RAM.

PCI - Peripheral Component Interconnect - a high speed interface for video cards, sound cards, network interface cards, and modems; runs at 33MHz.

PCI Express- Peripheral Component Interconnect Express- a high speed interface for video cards, sound cards, network interface cards, and modems.

PCI Express2.0- Peripheral Component Interconnect Express2.0, developed in 2003, the speed of each line doubled from the previous PCI-E of 2.5Gbps to 5 Gbps.

Serial Port - a low speed interface typically used for mouse and external modems.

Parallel Port - a low speed interface typically used for printers.

PS/2 - a low speed interface used for mouse and keyboards.

USB - Universal Serial Bus - a medium speed interface typically used for mouse, keyboards, scanners, and some digital cameras.

Sound (interface) - the interface between the sound card or integrated sound connectors and speakers, MIC, game controllers, and MIDI sound devices.

LAN (interface) - Local Area Network - the interface to your local area network.

BIOS (Basic Input/Output System) - the program logic used to boot up a computer and establish the relationship between the various components.

Driver - software, which defines the characteristics of a device for use by another device or other software.

Processor - the "central processing unit" (CPU); the principal integrated circuit used for doing the "computing" in "personal computer"

Front Side Bus Frequency - the working frequency of the motherboard, which is generated by the clock generator for CPU, DRAM and PCI BUS.

CPU L2 Cache - the flash memory inside the CPU, normal it depend on CPU type.

2-3-2 About AMD Athlon64 Socket AM2

This motherboard provides a surface mount, Zero Insertion Force (ZIF) socket, referred to as the mPGA940 socket supports AMD Athlon64 processor in the package utilizes Flip-Chip Pin Grid Array package technology.

The CPU that comes with the motherboard should have a cooling fan attached to prevent overheating. If this is not the case, then purchase a correct cooling fan before you turn on your system.

WARNING! Be sure that there is sufficient air circulation across the processor's heatsink and CPU cooling FAN is working correctly, otherwise it may cause the processor and motherboard overheat and damage, you may install an auxiliary cooling FAN, if necessary.

To install a CPU, first turn off your system and remove its cover. Locate the ZIF socket and open it by first pulling the level sideways away from the socket then upward to a 90-degree angle. Insert the CPU with the correct orientation as shown below. The notched corner should point toward the end of the level. Because the CPU has a corner pin for two of the four corners, the CPU will only fit in the orientation as shown.

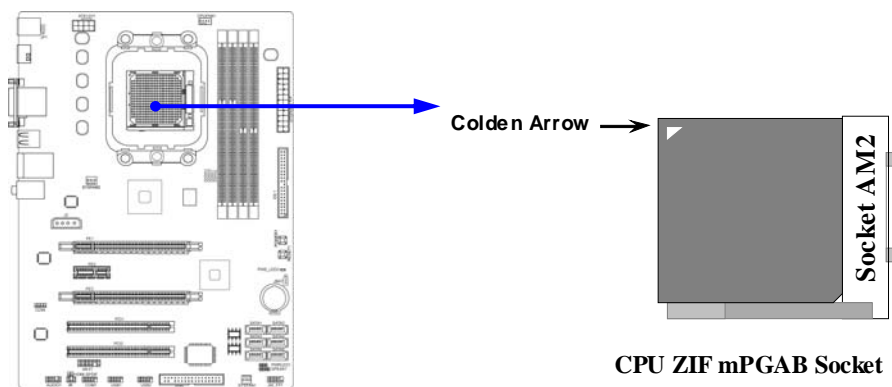

When you put the CPU into the ZIF socket, No force required to insert of the CPU, and then press the level to locate position slightly without any extra force.

2-4 Install Memory

This motherboard provides two 240-pin DDR II DUAL INLINE MEMORY MODULES (DIMM) socket for DDR II memory SDRAM expandable to maximum memory volume of 4 GB and two 240-pin DDR III SDRAM DUAL INLINE MEMORY MODULES (DIMM) socket for DDR III memory SDRAM expandable to maximum memory volume of 4 GB.

Valid Memory Configurations for DDR II

Bank	240-Pin DIMM	PCS	Maximum Capacity
DDRII1	DDR II 667/ DDR II 800/DDR II 1066	X1	2GB
DDR II2	DDR II 667/ DDR II 800/DDR II 1066	X1	2GB
Total	System Memory (Max 2GB)	2	4GB

Valid Memory Configuration for DDR III

Bank	240-Pin DIMM	PCS	Maximum Capacity
DDR III1	DDR III 1333/DDR III 1066/DDR III 800	X1	2GB
DDR III 2	DDR III 1333/DDR III 1066/DDR III 800	X1	2GB
Total	System Memory (Max 2 GB)	2	4GB

NOTICE!

1. Dual channel function only supports when 2 DIMM Modules plug in either both DDR III 1 & DDR III 2 or DDR II 1 & DDR II 2.
2. Memory modules in DDR III 1 & DDR III 2 or DDR II 1 & DDR II 2 must be of the same type, same size, and same frequency for dual channel function.
3. DDR II 1 and DDR II 2 is for installing DDR II memory modules only while DDR III 1 and DDR III 2 is for installing DDR III memory modules only.
4. User can only install DDR II memory module(s) in DDR II memory module slot(s) when an AM2 or AM2+ CPU is installed;
5. User can choose either installing DDR II memory module(s) in DDR II memory module slot(s) or DDR III memory module(s) in DDR III memory module slot(s), but NEVER both DDR II and DDR III memory module(s) at the same time under any circumstances.

Install DDR SDRAM modules to your motherboard is not difficult, you can refer to figure below to see how to install a 240-Pin DDR II 667/DDR II 800/DDR II 1066 or a DDR III 1066 /**DDR III 1333** SDRAM module.

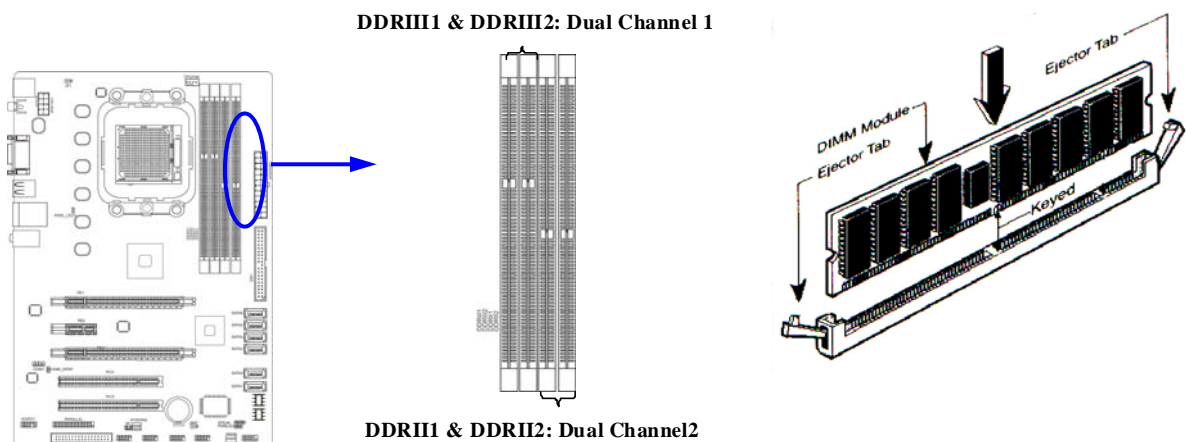

NOTICE!

When you install DIMM module fully into the DIMM socket the eject tab should be locked into the DIMM module very firmly and fit into its indentation on both sides.

2-5 Expansion Cards

2-5-1 Procedure For Expansion Card Installation

1. Read the documentation for your expansion card and make any necessary hardware or software setting for your expansion card such as jumpers.
2. Remove your computer's cover and the bracket plate on the slot you intend to use.
3. Align the card's connectors and press firmly.
4. Secure the card on the slot with the screen you remove above.
5. Replace the computer system's cover.
6. Set up the BIOS if necessary.
7. Install the necessary software driver for your expansion card.

2-5-2 Assigning IRQs For Expansion Card

Some expansion cards need an IRQ to operate. Generally, an IRQ must exclusively assign to one use. In a standard design, there are 16 IRQs available but most of them are already in use.

Standard Interrupt Assignments

IRQ	Priority	Standard function
0	N/A	System Timer
1	N/A	Keyboard Controller
2	N/A	Programmable Interrupt
3 *	8	Communications Port (COM2)
4 *	9	Communications Port (COM1)
5 *	6	Sound Card (sometimes LPT2)
6 *	11	Floppy Disk Controller
7 *	7	Printer Port (LPT1)
8	N/A	System CMOS/Real Time Clock
9 *	10	ACPI Mode when enabled
10 *	3	IRQ Holder for PCI Steering
11 *	2	IRQ Holder for PCI Steering
12 *	4	PS/2 Compatible Mouse Port
13	N/A	Numeric Data Processor
14 *	5	Primary IDE Channel
15 *	1	Secondary IDE Channel

* These IRQs are usually available for ISA or PCI devices.

IMPORTANT!

If using PCI cards on shared slots, make sure that the drivers support "Shared IRQ" or that the cards don't need IRQ assignments. Conflicts will arise between the two PCI groups that will make the system unstable or cards inoperable.

2-5-3 PCI Express 2.0 Slot

This motherboard series offers one PCI-Express2.0 x16 By 16-lane graphics slot, one PCI-Express2.0 x16 By 4-lane graphics slots and one PCI-Express2.0 x1 graphics slot for astonishing performance with brilliant and intense 3D graphics The motherboard also carries two 32-bit PCI slots guarantee the rich connectivity for the I/O peripheral devices.

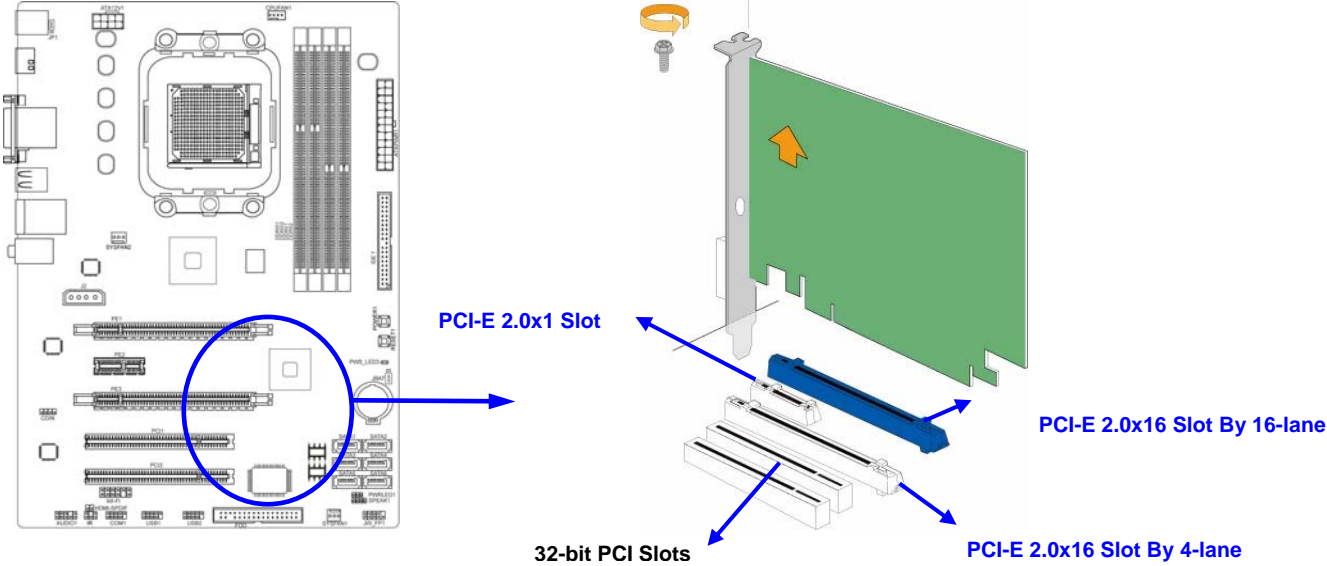

2-6 Connectors, Headers

2-6-1 Connectors

(1) Power Connector (24-pin block) : ATXPWR1

ATX Power Supply connector: This is a new defined 24-pins connector that usually comes with ATX case. The ATX Power Supply allows using soft power on momentary switch that connect from the front panel switch to 2-pins Power On jumper pole on the motherboard. When the power switch on the back of the ATX power supply turned on, the full power will not come into the system board until the front panel switch is momentarily pressed. Press this switch again will turn off the power to the system board.

- ** We recommend that you use an ATX 12V Specification 2.0-compliant power supply unit (PSU) with a minimum of 350W power rating. This type has 24-pin and 4-pin power plugs.
- ** If you intend to use a PSU with 20-pin and 4-pin power plugs, make sure that the 20-pin power plug can provide at least 15A on +12V and the power supply unit has a minimum power rating of 350W. The system may become unstable or may not boot up if the power is inadequate.

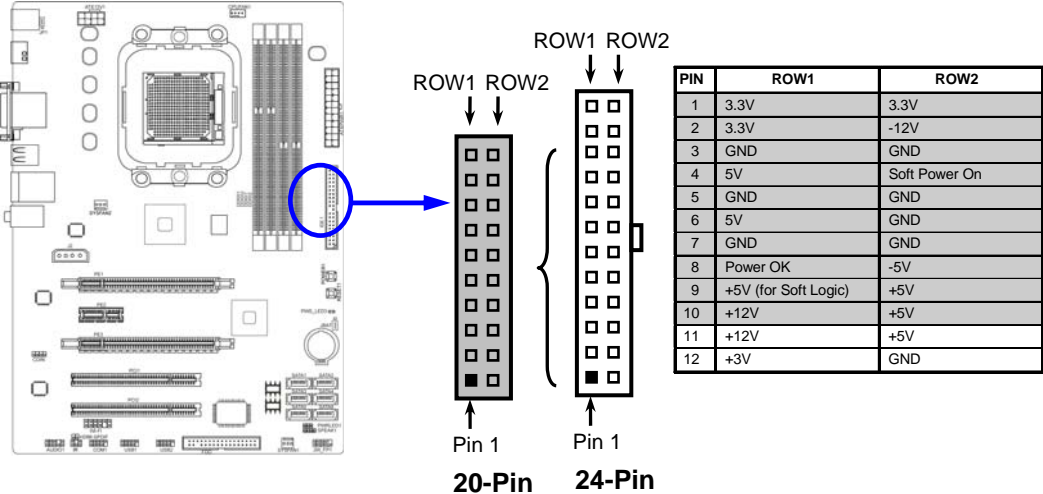

(2) ATX 12V Power Connector (8-pin block) : ATX12V1

This is a new defined 8-pins connector that usually comes with ATX Power Supply. The ATX Power Supply which fully supports Socket AM2+ processor must including this connector for support extra 12V voltage to maintain system power consumption. Without this connector might cause system unstable because the power supply can not provide sufficient current for system.

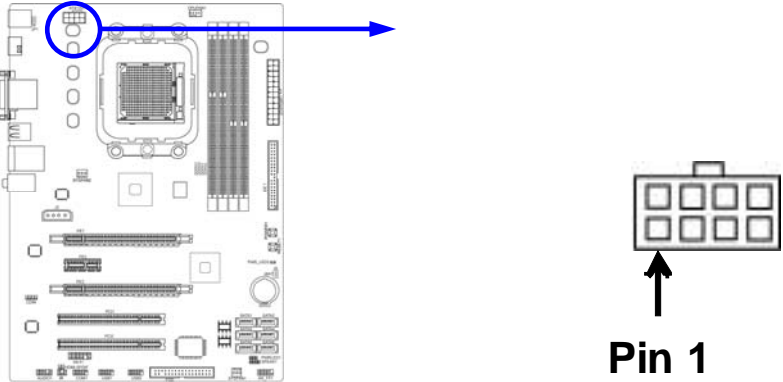

(3) PS/2 Mouse & PS/2 Keyboard Connector: KB

The connectors are for PS/2 keyboard and PS/2 Mouse.

(4) USB Port connector: USB from CN1, UL1

The connectors are 4-pin connector that connects USB devices to the system board.

(5) LAN Port connector: RJ-45 LAN from UL1

This connector is standard RJ45 connector for Network which supports 10M/100Mb/1000Mbps data transfer rate

(6) Large 4-Pin Power Connector: J2 Power Connector

The connectors are 4-pin connector that supports extra 12V / 5V power to your system .

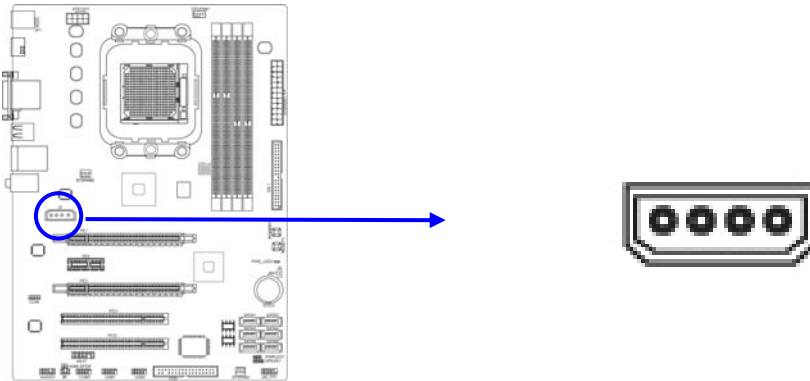

(7) Audio Line-In, Lin-Out, MIC Connector : CN2 for Audio

These Connectors are 3 Phone-Jack for LINE-OUT, LINE-IN, MIC audio connections.

Line-in : Audio input to sound chip

Line-out : Audio output to speaker

MIC : Microphone Connector

XBLUE-77A3

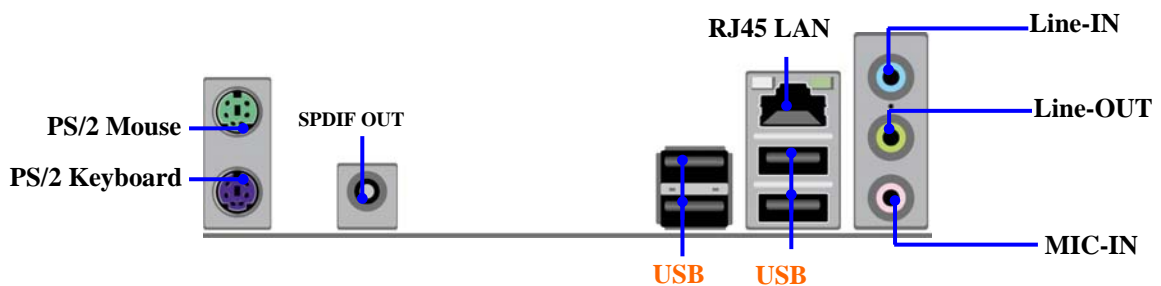

XBLUE-78GA3/XBLUE-78VA3

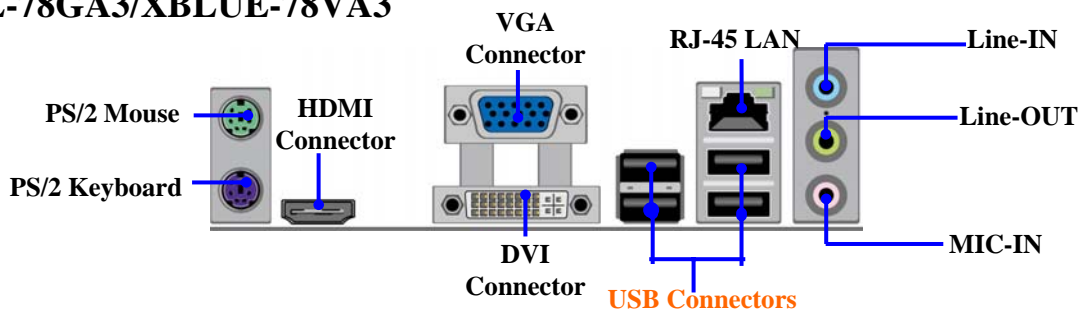

(8) Floppy drive Connector (34-pin block): FDD1

This connector supports the provided floppy drive ribbon cable. After connecting the single plug end to motherboard, connect the two plugs at other end to the floppy drives.

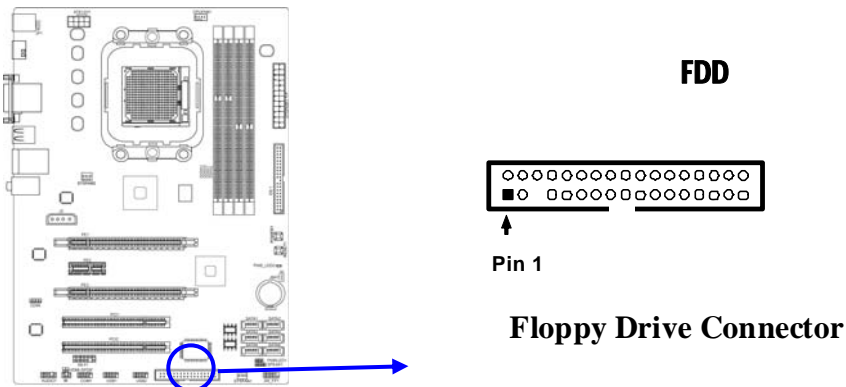

(9) Primary IDE Connector (40-pin block): IDE1

This connector supports the provided IDE hard disk ribbon cable. After connecting the single plug end to motherboard, connect the two plugs at other end to your hard disk(s). If you install two hard disks, you must configure the second drive to Slave mode by setting its jumpers accordingly. Please refer to the documentation of your hard disk for the jumper settings.

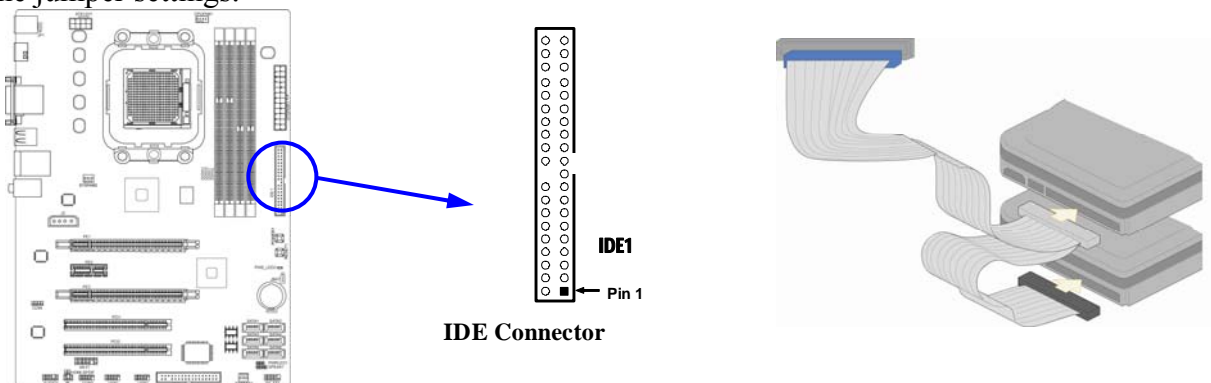

- Two hard disks can be connected to each connector. The first HDD is referred to as the “Master” and the second HDD is referred to as the “Slave”.
- For performance issues, we strongly suggest you don’t install a CD-ROM or DVD-ROM drive on the same IDE channel as a hard disk. Otherwise, the system performance on this channel may drop.

(10) Serial-ATAII Port connector:SATA1~SATA6

These connectors support the provided Serial ATA2 hard disk cables to connecting the motherboard with serial ATAII hard disks. E-SATA1 is not for SATA hard drive, it is only for connecting to a SATA connector of the D-SATA1, D-SATA2 or D-SATA3 to let the ESATA port work.

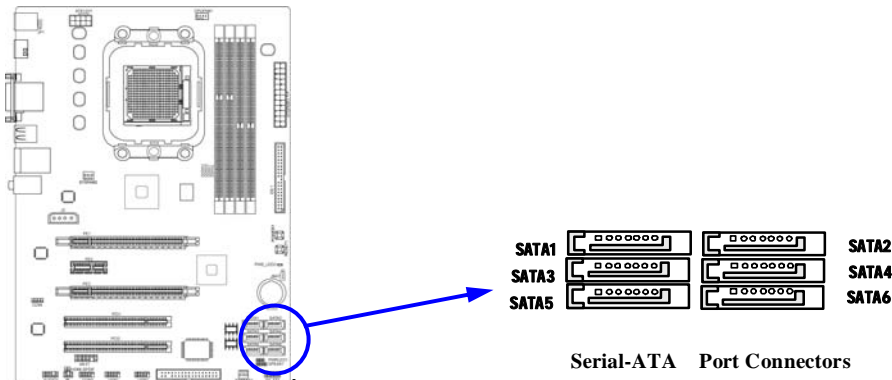

(11) D-Sub 15-pin connector:VGA

VGA connector is the 15-pin D-subminiature female connector; it is for the display devices, such as the CRT monitor, LCD monitor and so on.

(12) Digital Visual Interface: DVI

This interface standard designed to maximize the visual quality of digital display devices such as flat panel LCD computer displays and digital projectors.

(13) HDMI: High-Definition Multimedia Interface

This point-to-point interface is for audio and video signals designed as a single-cable solution for home theater and consumer electronics equipment.

NOTE! DVI and HDMI Connector can not be used at the same time.

(14)Coaxial SPDIF_OUT connector: SPDIF_OUT1

The SPDIF output is capable of providing digital audio to external speakers or compressed AC3 data to an external Dolby digital decoder. Use this feature only when your stereo system has digital input function.

2-6-2 Headers

(1) Line-Out/MIC Header for Front Panel (9-pin): AUDIO1

These headers connect to Front Panel Line-out, MIC connector with cable.

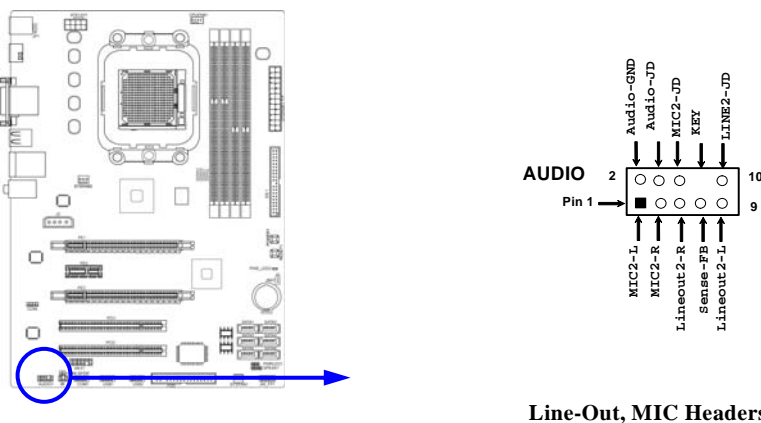

Line-Out, MIC Headers

(2) USB Port Headers (9-pin): USB1/USB2

These headers are used for connecting the additional USB port plug. By attaching an option USB cable, your can be provided with two additional USB plugs affixed to the back panel.

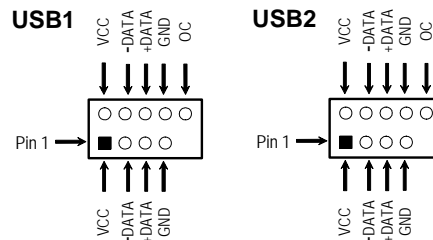
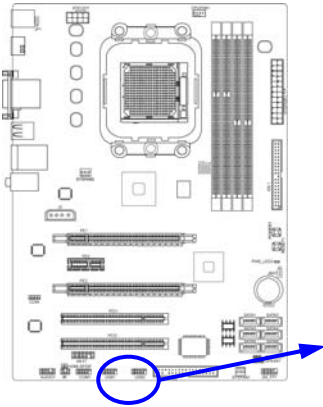

USB Port Headers

(3) Speaker connector: SPEAK1

This 4-pin connector connects to the case-mounted speaker. See the figure below.

(4) Power LED: PWR LED1/ PWR LED

The Power LED is light on while the system power is on. Connect the Power LED from the system case to this pin.

(5) IDE Activity LED: HD LED

This connector connects to the hard disk activity indicator light on the case.

(6) Reset switch lead: RESET

This 2-pin connector connects to the case-mounted reset switch for rebooting your computer without having to turn off your power switch. This is a preferred method of rebooting in order to prolong the life of the system's power supply. See the figure below.

(7) Power switch: PWR BTN

This 2-pin connector connects to the case-mounted power switch to power ON/OFF the system.

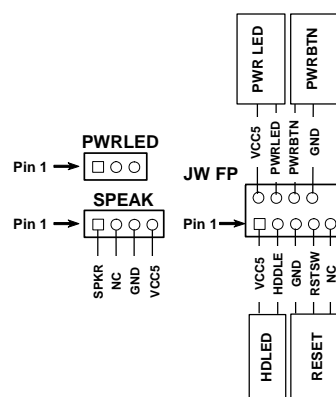
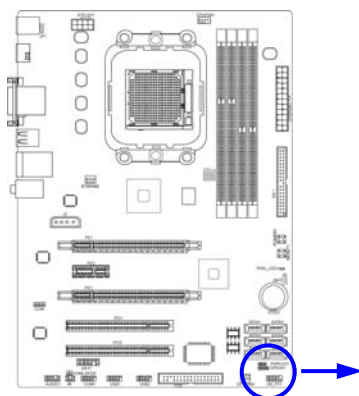

System Case Connections

(8) FAN Power Headers: SYSFAN1, SYSFAN2, CPUFAN (4-pin)

These connectors support cooling fans of 350mA (4.2 Watts) or less, depending on the fan manufacturer, the wire and plug may be different. The red wire should be positive, while the black should be ground. Connect the fan's plug to the board taking into consideration the polarity of connector.

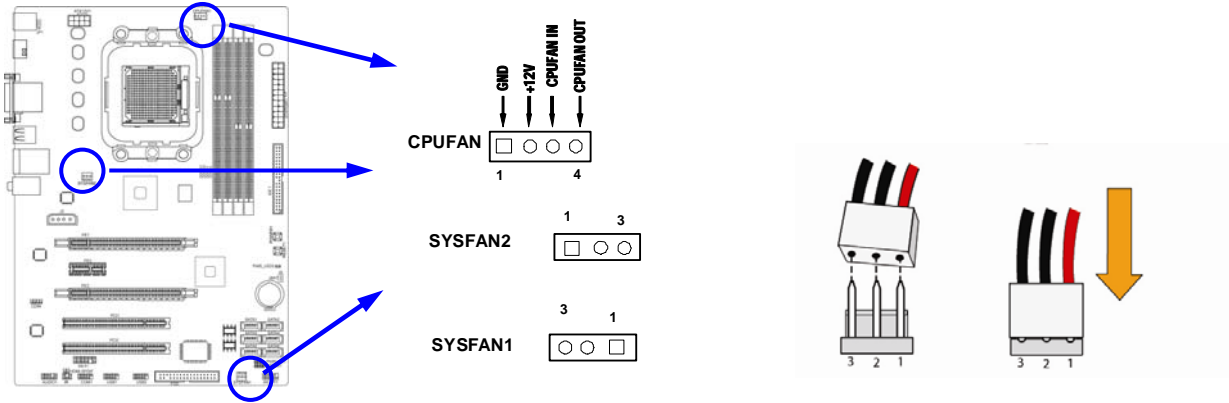

FAN Power Headers

(9) CD Audio-In Headers (4-pin): CDIN1

CDIN are the connectors for CD-Audio Input signal. Please connect it to CD-ROM CD-Audio output connector.

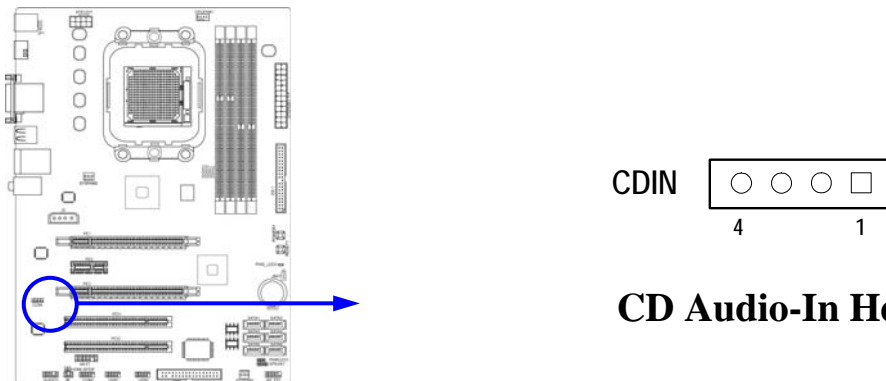

CD Audio-In Headers

(10) IR infrared module Headers (5-pin): IR

This connector supports the optional wireless transmitting and receiving infrared module. You must configure the setting through the BIOS setup to use the IR function.

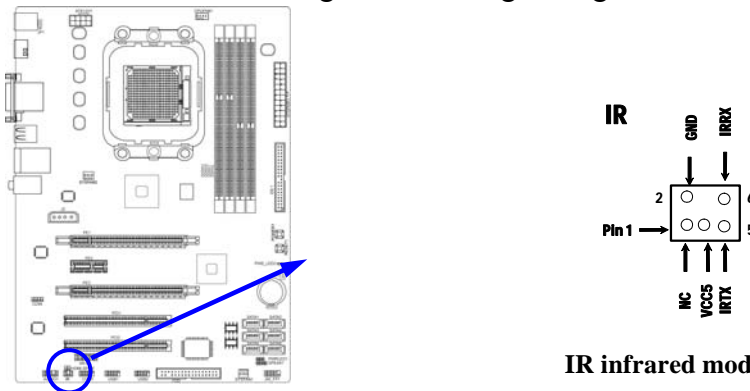

IR infrared module Headers

(11) Serial Port Header : COM1

COM1 is a 9-pin serial port header.

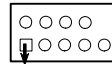
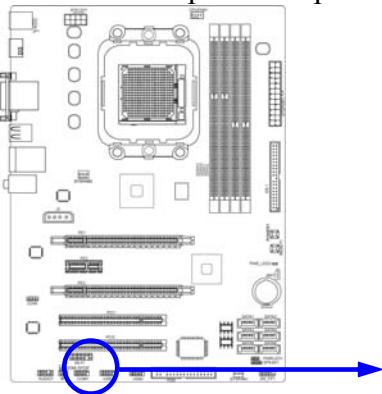

Pin 1

Serial COM Port 9-pin Block

(12) HDMI_SPDIF Out header: SPDIF Out

The SPDIF output is capable of providing digital audio to external speakers or compressed AC3 data to an external Dolby digital decoder. Use this feature only when your stereo system has digital input function.

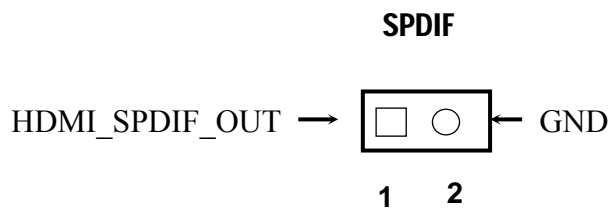
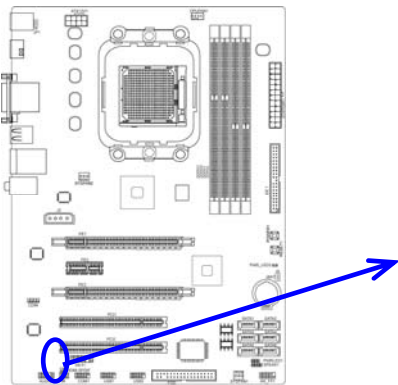

(13) WI-FI Header:

This header supports WI-FI Function. Connect the wireless local area network adapter to this header. It allows you to create a wireless environment and enjoy the convenience of wireless network connectivity.

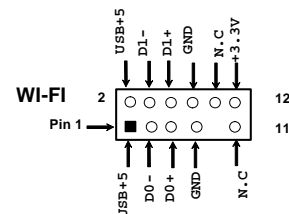
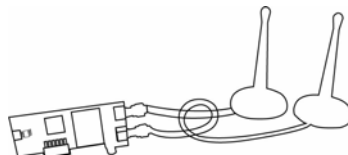
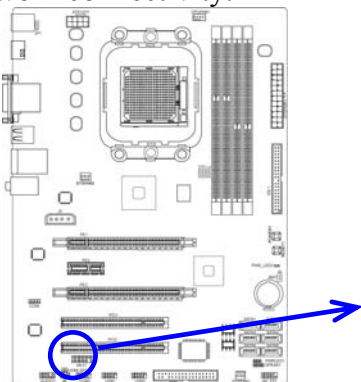

WI-FI Headers

2-7 Starting Up Your Computer

1. After all connection are made, close your computer case cover.
2. Be sure all the switch are off, and check that the power supply input voltage is set to proper position, usually in-put voltage is 220V~240V or 110V~120V depending on your country's voltage used.
3. Connect the power supply cord into the power supply located on the back of your system case according to your system user's manual.
4. Turn on your peripheral as following order:
 - a. Your monitor.
 - b. Other external peripheral (Printer, Scanner, External Modem etc...)
 - c. Your system power. For ATX power supplies, you need to turn on the power supply and press the ATX power switch on the front side of the case.
5. The power LED on the front panel of the system case will light. The LED on the monitor may light up or switch between orange and green after the system is on. If it complies with green standards or if it is has a power standby feature. The system will then run power-on test. While the test is running, the BIOS will alarm beeps or additional message will appear on the screen.

If you do not see any thing within 30 seconds from the time you turn on the power. The system may have failed on power-on test. Recheck your jumper settings and connections or call your retailer for assistance.

6. During power-on, press <Delete> key to enter BIOS setup. Follow the instructions in BIOS SETUP.
7. **Power off your computer:** You must first exit or shut down your operating system before switch off the power switch. For ATX power supply, you can press ATX power switching after exiting or shutting down your operating system. If you use Windows 9X, click "**Start**" button, click "**Shut down**" and then click "**Shut down the computer?**" The power supply should turn off after windows shut down.

Chapter 3

Introducing BIOS

The BIOS is a program located on a Flash Memory on the motherboard. This program is a bridge between motherboard and operating system. When you start the computer, the BIOS program will gain control. The BIOS first operates an auto-diagnostic test called POST (power on self test) for all the necessary hardware, it detects the entire hardware device and configures the parameters of the hardware synchronization. Only when these tasks are completed done it gives up control of the computer to operating system (OS). Since the BIOS is the only channel for hardware and software to communicate, it is the key factor for system stability, and in ensuring that your system performance as its best.

In the BIOS Setup main menu of Figure 3-1, you can see several options. We will explain these options step by step in the following pages of this chapter, but let us first see a short description of the function keys you may use here:

- Press <Esc> to quit the BIOS Setup.
- Press ↑↓←→ (up, down, left, right) to choose, in the main menu, the option you want to confirm or to modify.
- Press <F10> when you have completed the setup of BIOS parameters to save these parameters and to exit the BIOS Setup menu.
- Press <+>/<-> keys when you want to modify the BIOS parameters for the active option.

3-1 Entering Setup

Power on the computer and by pressing immediately allows you to enter Setup.

If the message disappears before your respond and you still wish to enter Setup, restart the system to try again by turning it OFF then ON or pressing the “RESET” button on the system case. You may also restart by simultaneously pressing <Ctrl>, <Alt> and <Delete> keys. If you do not press the keys at the correct time and the system does not boot, an error message will be displayed and you will again be asked to

Press to enter Setup

3-2 Getting Help

Main Menu

The on-line description of the highlighted setup function is displayed at the bottom of the screen.

Status Page Setup Menu/Option Page Setup Menu

Press F1 to pop up a small help window that describes the appropriate keys to use and the possible selections for the highlighted item. To exit the Help Window, press <Esc>.

3-3 The Main Menu

Once you enter AMI BIOS Setup Utility, the Main Menu (Figure 3-1) will appear on the screen. The Main Menu allows you to select from 12 setup functions and 2 exit choices. Use arrow keys to select among the items and press <Enter> to accept or enter the sub-menu.
XBLUE- 77A3

CMOS Setup Utility-Copyright(C)1985-2005 American Megatrends. Inc.

<ul style="list-style-type: none"> ▶ Standard BIOS Features ▶ Advanced BIOS Features ▶ Advanced Chipset Features ▶ Integrated Peripherals ▶ Power Management Features ▶ Miscellaneous Control ▶ Hardware Health Configure 	<ul style="list-style-type: none"> ▶ Thermal Throttling Function ▶ Power User OverClock Settings ▶ BIOS Security Features Load Optimal Defaults Load Standard Defaults Save Changes and Exit Discard Changes and Exit
↑↓→←: Move Enter: Select +/-/: Value F10: Save ESC:Exit F1:General Help F5: Discard Changes F6:Standard Settings F7: Optimized Settings	
V02.66(C)Copyright 1985-2008, American Megatrends. Inc.	

XBLUE- 78GA3/XBLUE- 78VA3

CMOS Setup Utility-Copyright(C)1985-2005 American Megatrends. Inc.

<ul style="list-style-type: none"> ▶ Standard BIOS Features ▶ Advanced BIOS Features ▶ Advanced Chipset Features ▶ Integrated Peripherals ▶ Power Management Features ▶ Miscellaneous Control ▶ PC Health Status 	<ul style="list-style-type: none"> ▶ Thermal Throttling Option ▶ Power User Overclock Settings ▶ Password Settings Load Optimal Defaults Load Failsafe Defaults Save Changes and Exit Discard Changes and Exit
↑↓→←: Move Enter: Select +/-/: Value F10: Save ESC:Exit F1:General Help F5: Previous Values F6: Fail-Safe Defaults F7: Optimized Defaults	
V02.63(C)Copyright 1985-2008, American Megatrends. Inc.	

Figure 3-1

Standard CMOS Features

Use this Menu for basic system configurations.

Advanced BIOS Features

Use this menu to set the Advanced Features available on your system.

Advanced Chipset Features

Use this menu to change the values in the chipset registers and optimize your system's performance.

Integrated Peripherals

Use this menu to specify your settings for integrated peripherals.

Power Management Features

Use this menu to specify your settings for power management.

Miscellaneous Control

Use this menu to specify your settings for Miscellaneous Control.

PC Health Status/Hardware Health Configure

This entry shows your PC health status.

Power User Overclock Settings

Use this menu to specify your settings (frequency, Voltage) for overclocking demand.

CPU Thermal Throttling Setting

The selection is set for activating the active CPU Thermal Protection by flexible CPU loading adjustment in the range of temperature you define.

Load Failsafe Defaults

This menu uses a minimal performance setting, but the system would run in a stable way.

Load Optimized Defaults

Use this menu to load the BIOS default values these are setting for optimal performances system operations for performance use.

Password Settings/BIOS Security Feature

This entry for setting Supervisor password and User password

Save Changes and Exit

Save CMOS value changes to CMOS and exit setup.

Discard Changes and Exit

Abandon all CMOS value changes and exit setup.

3-4 Standard BIOS Features

The items in Standard CMOS Setup Menu are divided into several categories. Each category includes no, one or more than one setup items. Use the arrow keys to highlight the item and then use the <+> or <-> and numerical keyboard keys to select the value you want in each item.

XBLUE- 77A3

CMOS Setup Utility-Copyright(C)1985-2005 American Megatrends. Inc.
Standard BIOS Features

System Date	Wed 01/07/2009	Help Item
System Time	22 : 46 : 33	While entering setup, BIOS auto detects the presence of the IDE devices. This displays the status of suto detection of the IDE devices.
▶ IDE Channel0 Master	Harddisk	
▶ IDE Channel0 Slave	Not Detected	
▶ SATA Channel 1	Not Detected	
▶ SATA Channel 2	Not Detected	
▶ SATA Channel 3	Not Detected	
▶ SATA Channel 4	Not Detected	
▶ SATA Channel 5	Not Detected	
▶ SATA Channel 6	Not Detected	
▶ FLOPPY A	1.44MB, 3 $\frac{1}{2}$ "	
System Memory		
Size: 512 MB		
↑↓→←: Move Enter: Select +/-/: Value F10: Save ESC:Exit F1:General Help F5: Discard Changes F6:Standard Settings F7: Optimized Settings		

XBLUE- 78GA3/XBLUE- 78VA3

CMOS Setup Utility-Copyright(C)1985-2005 American Megatrends. Inc.
Standard BIOS Features

System Date	Wed 01/07/2009	Help Item
System Time	22 : 46 : 33	While entering setup, BIOS auto detects the presence of the IDE devices. This displays the status of suto detection of the IDE devices.
▶ Primary IDE Master	Not Detected	
▶ Primary IDE Slave	Not Detected	
▶ SATA Channel 5	Hard Disk	
▶ SATA Channel 6	Not Detected	
▶ SATA Channel 1	Not Detected	
▶ SATA Channel 3	Not Detected	
▶ SATA Channel 2	Not Detected	
▶ SATA Channel 4	Not Detected	
▶ FLOPPY A	1.44MB, 3 $\frac{1}{2}$ "	
System Memory		
Size: 448 MB		
↑↓→← Move Enter:Select +/-/PU/PD:Value F10:Save ESC:Exit F1:General Help F5:Previous Values F6:Fail-Safe Defaults F7:Optimized Defaults		

System Date

The date format is <day><month><date><year>.

- Day** Day of the week, from Sun to Sat, determined by BIOS. Read-only.
- Month** The month from Jan. through Dec.
- Date** The date from 1 to 31 can be keyed by numeric function keys.
- Year** The year depends on the year of the BIOS.

System Time

The time format is <hour><minute><second>.

Primary IDE Master / Slave

SATA Channel 1, 2, 3, 4, 5, 6

While entering setup, BIOS auto detect the presence of IDE devices. This displays the status of auto detection of IDE devices.

Type: The optional settings are: Not Installed; Auto; CD/DVD and ARMD

LBA/Large Mode: The optional settings are Auto; Disabled.

Block (Multi-Sector Transfer): The optional settings are: Disabled and Auto.

PIO Mode: the optional settings are: Auto, 0, 1, 2, 3 and 4.

DMA MODE: the optional settings are Auto, SWDMAN, MWDMAN, UDMAN.

S.M.A.R.T.: This option allows you to enable the HDD S.M.A.R.T Capability (Self-Monitoring, Analysis and Reporting Technology). The optional settings are Auto; Disabled; and ENABLED.

32 Bit Data Transfer: the optional settings are: Disabled and Enabled.

Floppy A

This item is for specific floppy disk drive settings. Select according to the specification of the floppy disk you use.

System Memory

This item will show information about the memory modules(s) installed.

3-5 Advanced BIOS Feature

XBLUE- 77A3

CMOS Setup Utility-Copyright(C)1985-2005 American Megatrends. Inc.

Advanced BIOS Features

Advanced Settings		Help Item
➤ CPU Configuration	Press Enter	Configure CPU
➤ Hard Disk Drives	Press Enter	
➤ Removable Drives	Press Enter	
Quick Boot	Enabled	
1 st BOOT Device	HDD: PM-WDC WD800	
2 nd Boot Device	1 st FLOPPY DRIVER	
Boot up Num-Lock	On	
ACPI APIC Support	Enabled	
MPS Revision	1.1	

↑↓←→: Move Enter: Select +/-/: Value F10: Save ESC:Exit F1:General Help
F5: Discard Changes F6:Standard Settings F7: Optimized Settings

XBLUE- 78GA3/XBLUE- 78VA3

CMOS Setup Utility-Copyright(C)1985-2005 American Megatrends. Inc.

Advanced BIOS Features

Advanced Settings	Help Item
WARNING: Setting wrong values in below sections May cause system to malfunction	Configure CPU
▶ CPU Configuration Press Enter	
▶ Hard Disk Drivers Press Enter	
▶ Removable Drivers Press Enter	
Quick Boot Enabled	
2 nd Boot Device HDD:PM-WDC WD800	
3 rd Boot Device 1st Floopy Driver	
Boot up Num-Lock On	
ACPI APIC Support Enabled	
MPS Revision Enabled	
Quiet Boot Disabled	
↑↓→← Move Enter:Select +/-/PU/PD:Value F10:Save ESC:Exit F1:General Help F5:Previous Values F6:Fail-Safe Defaults F7:Optimized Defaults	

Removable Drives

Use this item to specify the boot device priority sequence from available removable drives.

Quick Boot

Allows BIOS to skip certain tests while booting. This will decrease the needed to boot the system.

1st/2nd /3rd Boot Device/3rd Boot Device

Specify the boot sequence from the available devices. A device enclosed in parenthesis has been disabled in corresponding type menu.

Boot Up NumLock Status

The default value is On.

On (default) Keypad is numeric keys.

Off Keypad is arrow keys.

ACPI APIC Support

Include ACPI APIC table pointer to RSDT pointer list.

MPS Revision

This option is only valid for multiprocessor motherboards as it specifies the version of the Multiprocessor Specification (MPS) that the motherboard will use.

Quiet Boot

The optional settings are Enabled and Disable.

Disabled: Display normal POST message.

Enabled: Displays OME logo instead of POST message.

3-5-1 CPU Configuration

XBLUE- 77A3

CMOS Setup Utility-Copyright(C)1985-2005 American Megatrends. Inc.

CPU Configuration

CPU Configuration	Help Item
Module Version: 13.43 AGESA Version: 3.3.3.0 Physical Count:1 Logical Count:2	This option should remain disabled for the normal operation. The driver developer may enable it for testing purposr
AMD Athlon(tm)64x2 Dual Core Processor 4200+ Revision :G2 Cache L1 : 256 KB Cache L2 :1024KB Cache L3 : N/A Speed : 2200 MHz, NV CLK: N/A Current FSB Multiplier : 11X Able to change Freq. : Yes uCode Path Level : None Required	
GART Error Reporting Disabled Microcode Update Enabled Secure Virtual Machine Mode Enabled AMDCool&Quiet Control Enabled GPI Function Enabled CE1 Support Enabled ACPI SRAT Mode Enabled CPU Prefetching Enabled	
↑↓→←: Move Enter: Select +/-/: Value F10: Save ESC:Exit F1:General Help F5: Discard Changes F6:Standard Settings F7: Optimized Settings	

XBLUE- 78GA3/XBLUE-78VA3

CMOS Setup Utility-Copyright(C)1985-2005 American Megatrends. Inc.

CPU Configuration

CPU Configuration	Help Item
Module Version: 13.43 AGESA Version: 3.3.3.0 Physical Count:1 Logical Count:2	This option should remain disabled for the normal operation. The driver developer may enable it for testing purposr
AMD Athlon(tm)64x2 Dual Core Processor 4200+ Revision :G2 Cache L1 : 256 KB Cache L2 :1024KB Cache L3 : N/A Speed : 2200 MHz, NV CLK: N/A Current FSB Multiplier : 11X Able to change Freq. : Yes uCode Path Level : None Required	
GART Error Reporting Disabled Microcode Update Enabled Secure Virtual Machine Mode Enabled Cool&Quiet Control Enabled CE1 Support Enabled ACPI SRAT Mode Enabled CPU Prefetching Enabled	
↑↓→←: Move Enter: Select +/-/: Value F10: Save ESC:Exit F1:General Help F5:Previous Values F6:Fail-Safe Defaults F7:Optimized Defaults	

3-6 Advanced Chipset Features

The Advanced Chipset Features Setup option is used to change the values of the chipset registers. These registers control most of the system options in the computer.

XBLUE- 77A3

CMOS Setup Utility-Copyright(C)1985-2005 American Megatrends. Inc.
Advanced Chipset Features

▶ Memory Configuration	Press Enter	Help Item
▶ PCI Express Configuration	Press Enter	
↑↓→←: Move Enter: Select +/-/: Value F10: Save ESC:Exit F1:General Help F5: Discard Changes F6:Standard Settings F7: Optimized Settings		

XBLUE- 78GA3/XBLUE- 78VA3

CMOS Setup Utility-Copyright(C)1985-2005 American Megatrends. Inc.
Advanced Chipset Features

▶ Memory Configuration	Press Enter	Help Item
▶ Internal Graphics Configurat	Press Enter	
▶ PCI Express Configuration	Press Enter	Options
HDMI Audio	HDMI	Auto
NB Power Management Feature	Auto	HDMI
Primary Video Controller	PCI-GFX0-GPP-IGFX	DVI
↑↓→← Move Enter:Select +/-/PU/PD:Value F10:Save ESC:Exit F1:General Help F5:Previous Values F6:Fail-Safe Defaults F7:Optimized Defaults		

HDMI Audio

Use this item to select HDMI audio, the optional settings are: Auto, HDMI and DVI.

Primary Video Controller

This item is for user to choose primary video controller.

3-6-1 Memory Configuration

XBLUE- 77A3

CMOS Setup Utility-Copyright(C)1985-2005 American Megatrends. Inc.
Memory Configuration

DRAM Timing Mode	Auto	Help Item
Memory CLK:	: 266MHz	
CAS Latency (Tcl):	:4.0	Options
RAS/CAS Delay(Trcd):	:4 CLK	AUTO
Min Active RAS(Tras):	:12 CLK	DCT0
RAS/RAS Delay (Trrd)	:2 CLK	
Row Cycle(Trc)	:16 CLK	
Write Recover Time(Twr)	:4 CLK	
Bank Interleaving	Auto	
Enabled Clock to All DIMMs	Disabled	
Mem CLK Tristate C3/ATL VID	Disabled	
Memory Hole Remapping	Enabled	
DCI Unganged Mode	Always	
Power Down Mode	Disabled	
↑↓→←: Move Enter: Select +/-/: Value F10: Save ESC:Exit F1:General Help F5: Discard Changes F6:Standard Settings F7: Optimized Settings		

XBLUE- 78GA3/XBLUE- 78VA3

CMOS Setup Utility-Copyright(C)1985-2005 American Megatrends. Inc.

Memory Configuration

DRAM Timing Mode	Auto	Help Item
Memory CLK:	: 266MHz	
CAS Latency (Tcl):	:4.0	Options
RAS/CAS Delay(Trcd):	:4 CLK	
ROW Precharde Time(Trp)	:4CLK	
Min Active RAS(Tras):	:12 CLK	
RAS/RAS Delay (Trrd)	:2 CLK	
Row Cycle(Trc)	:16 CLK	
Write Recover Time(Twr)	:4 CLK	
Bank Interleaving	Auto	
Enabled clock to All DIMMs	Disabled	
MemCLK Tristate C3/ATLVID	Disabled	
Memory Hole Remapping	Enabled	
DCI Unganged Mode	Always	
Power Down Enabled	Enabled	
Power Down Mode	Channel	
↑↓→←: Move Enter: Select +/-/: Value F10: Save ESC:Exit F1:General Help F5:Previous Values F6:Fail-Safe Defaults F7:Optimized Defaults		

Bank Interleaving

Use this item to enable bank memory interleaving.

Enable Clock to ALL DIMMs

Enable unused clocks to DIMMS when memory slots are not populated.

Mem CLK Tristate during C3 and Alt VID.

Enable and disable Mem CLK Tri-stating during C3 and Alt VID

Memory Hole Remapping

Enable Memory Remapping around Memory Hole.

DCT Unganged Mode

This allows selection of unganged DRAM MODE (64- bit width).

Auto=Ganged Mode; Always= Unganged Mode.

Power Down Enable

Enable or Disable power down mode.

Power Down Mode

Set the DDR power down mode. The optional settings are Channel; Chipset.

3-6-2 Internal Graphics Configurations

XBLUE- 78GA3/XBLUE- 78VGA

CMOS Setup Utility-Copyright(C)1985-2005 American Megatrends. Inc.
Internal Graphics Configurations

Internal Graphics Mode	UMA	Help Item
UMA Frame Buffer Size	Auto	Options
GFX Engine Clock Override	Enabled	Below 4G
Surround View	Disabled	Above 4G
FB Location	Above 4G	
↑↓→← Move Enter:Select +/-/PU/PD:Value F10:Save ESC:Exit F1:General Help F5:Previous Values F6:Fail-Safe Defaults F7:Optimized Defaults		

UMA Frame Buffer Size

The optional settings are: Auto; 32MB; 64 MB; 128 MB; 256 MB and 512 MB.

Surround View

The item is for Hybrid CrossFire function. The optional settings are: Enabled; Disabled.

FB Location

The optional settings are: Above 4G and Below 4G.

3-6-3 PCI Express Configuration

XBLUE- 77A3

CMOS Setup Utility-Copyright(C)1985-2005 American Megatrends. Inc.
PCI Express Configuration

PCI Express Configuration	Help Item
Peer-to-Peer among GFX/GFX2	Options
Port # 02 Features	Enabled
Port #04 Features	Disabled
Port #09 Features	
Port #10 Features	
NB-SB Port Features	
↑↓→←: Move Enter: Select +/-/: Value F10: Save ESC:Exit F1:General Help F5: Discard Changes F6:Standard Settings F7: Optimized Settings	

XBLUE- 78GA3/XBLUE- 78VA3

CMOS Setup Utility-Copyright(C)1985-2005 American Megatrends. Inc.
PCIExpress Configuration

PCI Express Configuration	Help Item
GPP Slots Power Limit. W	Options
▶ Port # 02 Features	Auto
▶ Port # 03 Features	Enabled
▶ Port # 04 Features	Disabled
▶ Port # 09 Features	
▶ Port # 10 Features	
▶ NB-SB Port Features	
↑↓→← Move Enter:Select +/-/PU/PD:Value F10:Save ESC:Exit F1:General Help F5:Previous Values F6:Fail-Safe Defaults F7:Optimized Defaults	

Port #02 Features ~ Port #03 Features

Press Enter and set values in the sub-items as Ge2 High Speed Mode, Link ASPM, Link width , Slot Power Limit,w and Comliance Mode (780G/780V series motherboard) etc..

Port #04 Features~ Port #10 Features

Press Enter and set values in the sub-items as Ge2 High Speed Mode, Link ASPM and Comliance Mode (780G/780V series motherboard) etc..

NB-SB Port Features

Press Enter and set values in the sub-items as NB-SB Link ASPM,;NP NB-SB VC1 Traffic Support and Link Width and Comliance Mode (780G/780V series motherboard) etc..

3-7 Integrated Peripherals

XBLUE- 77A3

CMOS Setup Utility-Copyright(C)1985-2005 American Megatrends. Inc.
Integrated Peripherals

▶ Onboard SATA Device	Press Enter	Help Item
▶ Onboard Device Control	Press Enter	
▶ Super IO Configuration	Press Enter	
↑↓→← Move Enter: Select +/-/PU/PD: Value F10:Save ESC: Exit F1:General Help F5: Discard Changes F6:Standard Settings F7: Optimized Settings		

XBLUE- 78GA3/XBLUE- 78VA3

CMOS Setup Utility-Copyright(C)1985-2005 American Megatrends. Inc.
Integrated Peripherals

▶ Onboard SATA Device	Press Enter	Help Item
▶ Onboard Device Control	Press Enter	
▶ Super IO Configuration	Press Enter	
↑↓→← Move Enter: Select +/-/PU/PD: Value F10:Save ESC: Exit F1:General Help F5:Previous Values F6:Fail-Safe Defaults F7:Optimized Defaults		

3-7-1 Onboard SATA Device

XBLUE- 77A3

CMOS Setup Utility-Copyright(C)1985-2005 American Megatrends. Inc.
Onboard SATA Device

Onchip SATA Channel	Enabled	Help Item
Onchip SATA Type	Native IDE	
SATA IDE Combined Mode	Enabled	
Hard Disk Write Protect	Disabled	
IDE Detect Time Out(Sec)	35	
ATA (PI) 80 Pin Cable Detect	Host & Device	
↑↓→← Move Enter: Select +/-/: Value F10: Save ESC:Exit F1:General Help F5: Discard Changes F6:Standard Settings F7: Optimized Settings		

XBLUE- 78GA3/XBLUE-78VA3

CMOS Setup Utility-Copyright(C)1985-2005 American Megatrends. Inc.

Onboard SATA Device

Onchip SATA Channel	Enabled	Help Item
Onchip SATA Type	Native IDE	
Option ROM Combined Mode	Enabled	Select the time out value for detecting ATA/ATAPI device(s)
SATA IDECombined Mode	Enabled	
PATA Channel Config	SATA as Primary	
Onboard PCI IDE Controller	Both	
Hard Disk Write Protest	Disabled	
IDE Detect Time Out(Sec)	35	
ATA (PI) 80 Pin Cable Detect	Host & Device	
↑↓→← Move Enter:Select +/-/PU/PD:Value F10:Save ESC:Exit F1:General Help F5:Previous Values F6:Fail-Safe Defaults F7:Optimized Defaults		

OnChip SATA Channel

Press Enter to enable or disable CnChip SATA Channel.

On Chip SATA Type

Press Enter to select the SATA type. The optional settings are: Native IDE; RAID; AHCI; Legacy IDE; IDE→AHCI, Hyper Flash (optional)and IDE→Hyper Flash(optional).

Option ROM POST Delay

Optional settings are: Disabled; 0~7 Second(s).

Onboard PCI IDE Controller

The optional settings are Disabled; Primary ; Secondary and Both.

3-7-2 OnBoard Device Control

XBLUE- 77A3

CMOS Setup Utility-Copyright(C)1985-2005 American Megatrends. Inc.

Onborad Device Control

Onboard PCIE Lan Device	Enabled	Help Item
Onboard PCIE Lan BootROM	Disabled	
HD Audio Azalia Device	Enable	Options
Azalia Front Panel	Auto	Disabled
▶USB configuration	Press Enter	Enabled
↑↓→← Move Enter:Select +/-/PU/PD:Value F10:Save ESC:Exit F1:General Help F5: Discard Changes F6:Standard Settings F7: Optimized Settings		

XBLUE- 78GA3/XBLUE- 78VA3

CMOS Setup Utility-Copyright(C)1985-2005 American Megatrends. Inc.

Onboard Device Control

Onboard PCIE Lan	Enabled	Help Item
Onboard Lan BootRom	Disabled	
HD Audio Azalia Device	Enable	Options
Azalia Front Panel	Auto	Disabled
▶USB configuration	Press Enter	Enabled
↑↓→← Move Enter:Select +/-/PU/PD:Value F10:Save ESC:Exit F1:General Help F5:Previous Values F6:Fail-Safe Defaults F7:Optimized Defaults		

Onboard PCI E Lan Device

Use this item to enable or disable Onboard PCI E Lan

HD Audio Azalia Device

This item allows you to decide to enable/disable the chipset family to support HD Audio. The optional settings are: Auto; Enabled and Disabled.

USB Configuration

Press Enter to set values for sub-items as: Legacy USB Support, USB 2.0 Controller Mode BIOS EHCI Hand-Off.

3-7-3 Super IO Configuration

XBLUE- 77A3

CMOS Setup Utility-Copyright(C)1985-2005 American Megatrends. Inc.
Super IO Configuration

Configure F71863 Super IO Chipset	Help Item
Power On by Keyboard Disabled	Allows BIOS to Enable or Disable Floppy Controller
Power On by Mouse Disabled	
Onboard Floppy Controller Enabled	
Serial Port 1 Address 3F8/IRQ4	
Serial Port 2 Address 2F8/IRQ3	
Serial Port2 Mode Select IrDA (1.6 us)	
IR Duplex Mode Half Duplex	
IRTX Pin Select Normal	
IRRX Pin Select Normal	
IRTx to Rx Delay Select No Delay	
IRRx to Tx Delay Select No Delay	
PWRON After PWR-Fail Always Off	

↑↓→←: Move Enter: Select +/-/: Value F10: Save ESC:Exit F1:General Help
F5: Discard Changes F6:Standard Settings F7: Optimized Settings

XBLUE- 78GA3/XBLUE- 78VA3

CMOS Setup Utility-Copyright(C)1985-2005 American Megatrends. Inc.
Super IO Configuration

Configure F71863 Super IO Chipset	Help Item
Onboard Floppy Controller Enabled	Allows BIOS to Enable or Disable Floppy Controller
Serial Port 1 Address 3F8/IRQ4	
Serial Port 2 Address 2F8/IRQ3	
IrDA Mode Select IrDA (1.6 us)	
IR Duplex Mode Half Duplex	
IRTX Pin Select Normal	
IRRX Pin Select Normal	
IRTx to Rx Delay Select No Delay	
IRRx to Tx Delay Select No Delay	

↑↓→←: Move Enter: Select +/-/: Value F10: Save ESC:Exit F1:General Help
F5:Previous Values F6:Fail-Safe Defaults F7:Optimized Defaults

Onboard Floppy Controller

Select Enabled if your system has a floppy disk controller (FDD) installed on the system board and you wish to use it. If you install add-on FDC or the system has no floppy drive, select Disabled in this field. The settings are: Enabled and Disabled.

Serial Port1 Address/ Serial Port2 Address

Use this item to select serial port address for serial port one.

IrDA Mode Select

This item allows BIOS to select mode for serial port 2.

The optional settings are: IrDA(1.6 ns) and IrDA (3/16 bit).

IrDA Duplex Mode/Serial Port 2 Mode

This item allows BIOS to select full or half duplex for serial port 2(IR Mode).The optional settings are: Full Duplex; Half Duplex.

IrTX Pin Select

The optional settings are: Normal and Inverse.

This item allows BIOS to select transmit pin in a normal condition or inverse the IRTX(IR Mode).

IrRX Pin Select

The optional settings are: Normal and Inverse.

This item allows BIOS to select receiver pin in normal condition or inverse the IRRX(IR mode).

IRTX to RX Delay Select

The optional settings are: No Delay and Reception Delay.

This item allows BIOS to select IR from RX to TX 4 characters time delay for serial port2(IR mode)

IRRX to TX Delay Select

The optional settings are: No Delay and Transmission Delay.

3-8 Power Management Setup

The Power Management Setup allows you to configure your system to most effectively save energy saving while operating in a manner consistent with your own style of computer use.

XBLUE- 77A3

CMOS Setup Utility-Copyright(C)1985-2005 American Megatrends. Inc.

Power Management Setup

Power Management Feature		Help Item
Power Management/APM	Enabled	Disable/Enable RTC to generate a wake event
Suspend Time Out	Disabled	
Power Button Mode	On/Off	
Video Power Down Mode	Suspend	
Hard Disk Power Down Mode	Suspend	
Hard Disk Time Out (Minute)	Disabled	
RTC Resume	Disabled	
↑↓→← Move Enter:Select +/-/PU/PD:Value F10:Save ESC:Exit F1:General Help F5: Discard Changes F6:Standard Settings F7: Optimized Settings		

XBLUE- 78GA3/XBLUE- 78VA3

CMOS Setup Utility-Copyright(C)1985-2005 American Megatrends. Inc.

Power Management Setup

Power Management Feature		Help Item
Power Management/APM	Enabled	Disable/Enable RTC to generate a wake event
Suspend Time Out	Disabled	
Power Button Mode	On/Off	
Video Power Down Mode	Suspend	
Hard Disk Power Down Mode	Suspend	
Hard Disk Time Out (Minute)	Disabled	
Restore on AC Power Loss	Disabled	
RTC Resume	Disabled	
↑↓→← Move Enter:Select +/-/PU/PD:Value F10:Save ESC:Exit F1:General Help F5:Previous Values F6:Fail-Safe Defaults F7:Optimized Defaults		

Advanced ACPI Configuration

Use this section to configure additional ACPI options.

Power Management/APM

Use this item to enable or disable AMI based power management and APM support.

Suspend Time Out

If it is set Enabled and no activity during this time period, the BIOS will place the system into suspend low power state. The optional settings are: Enable; 1~64 minutes.

Power Button Mode

The optional settings are: On/Off; Suspend.

Video Power Down Mode

The optional settings are: Disabled; Standby and Suspend.

Restore on AC Power Loss

The optional settings are: Disabled; Power on; Power Off and last state.

3-9 Miscellaneous Control

XBLUE- 77A3

CMOS Setup Utility-Copyright(C)1985-2005 American Megatrends. Inc.
Miscellaneous Control

Advanced PCI/PnP Setting	Help Item
WARNING: Setting wrong values in below sections may cause system to malfunction	Options Clear NVRAM during System Boot
Clear NVRAM No	
Plug &Play O/S No	
PCI Latency Timer 64	
Allocate IRQ to PCI VGA Yes	
Palette Snooping Disabled	
PCI IDE Bus Master Disabled	
Offboard PCI/ISA IDE Card Auto	
▶ IRQ Resources Press Enter	
↑↓→← Move Enter:Select +/-/PU/PD:Value F10:Save ESC:Exit F1:General Help F5: Discard Changes F6:Standard Settings F7: Optimized Settings	

XBLUE- 78GA3/ XBLUE- 78VA3

CMOS Setup Utility-Copyright(C)1985-2005 American Megatrends. Inc.
Miscellaneous Control

Advanced PCI/PnP Setting	Help Item
WARNING: Setting wrong values in below sections may cause system to malfunction	Options Clear NVRAM during System Boot
Clear NVRAM No	
Plug &Play O/S No	
PCI Latency Timer 64	
Allocate IRQ to PCI VGA Yes	
Palette Snooping Disabled	
PCI IDE Bus Master Enabled	
▶ IRQ Resources Press Enter	
↑↓→← Move Enter:Select +/-/PU/PD:Value F10:Save ESC:Exit F1:General Help F5:Previous Values F6:Fail-Safe Defaults F7:Optimized Defaults	

Plug &Play O/S

The optional settings are: No; Yes

No: Let the BIOS configure all the devices in the system.

Yes: Let the operating system configure Plug and Play devices, not required for boot if your system has a Plug and Play system.

Allocate IRQ for PCI VGA

The optional settings are: No; Yes.

Yes: Assigns IRQ to PCI VGA card if card requests IRQ.

No: Does not assign IRQ to PCI VGA card even card requests an IRQ.

Palette Snooping

The optional settings are: Enabled; Disabled.

Enable: inform the PCI device that an ISA graphics devices is installed in the system so the card will function correctly.

PCI IDE Bus Master

The optional settings are: Enabled; Disabled.

Enable: BIOS uses PCI busmastering for reading/writing IDE devices.

Offboard PCI/ISA IDE Card

Some PCI IDE cards may require this to be set to the PCI slot number that is holding the card.

3-10 Hardware Health Configure/PC Health Status

This section shows the Status of you CPU, Fan, and Warning for overall system status. This is only available if there is Hardware Monitor onboard.

XBLUE- 77A3

CMOS Setup Utility-Copyright(C)1985-2005 American Megatrends. Inc.

Hardware Health Configure

PC Health Status		Help Item
▶Smart FAN Configuration	Press Enter	
H/W Health Function	Enabled	
CPU Temperature:	50°C/122°F	
System Temperature:	60°C/140°F	
CPUFAN1 Speed:	2923RPM	
SYSFAN1 Speed:	N/A	
SYSFAN 2 Speed:	N/A	
VLDT:	1.160V	
VDIMM :	2.688V	
Vcore:	1.132V	
VNB:	1.128V	
↑↓←→ Move Enter:Select +/-/PU/PD:Value F10:Save ESC:Exit F1:General Help F5: Discard Changes F6:Standard Settings F7: Optimized Settings		

XBLUE- 78GA3/XBLUE-78VA3

CMOS Setup Utility-Copyright(C)1985-2005 American Megatrends. Inc.

PC Health Status

PC Health Status		Help Item
▶ Smart FAN Configuration	Press Enter	
H/W Health Function	Enabled	
CPU Temperature:	50°C/122°F	
System Temperature:	60°C/140°F	
CPUFAN Speed:	2923RPM	
SYSFAN1 Speed:	N/A	
SYSFAN Speed:	N/A	
NB1.2V :	1.160V	
VDIMM :	2.688V	
VCORE:	1.132V	
NBPCIE:	1.128V	
↑↓← Move Enter:Select +/-/PU/PD:Value F10:Save ESC:Exit F1:General Help F5:Previous Values F6:Fail-Safe Defaults F7:Optimized Defaults		

H/W Health Function,

it displays information list below when set as below. The choice is either Enabled or Disabled.

CPU Temperature/ System Temperature/CPUFAN/SYSFAN1 Speed/SYSFAN2 Speed /VLDT/NB//NB1.2V/VDIMM/VCORE/NBPCIE

This will show the CPU/ /System voltage chart and FAN Speed, etc.

3-11 Thermal Throttling Options

XBLUE- 77A3

CMOS Setup Utility-Copyright(C)1985-2005 American Megatrends. Inc.

Thermal Throttling Options

CPU Thermal-Throttling	Enabled	Help Item
CPU Throttling Temp	70°C	Options
CPU Throttling Duty	50%	Disabled
		Enabled
↑↓← Move Enter:Select +/-/PU/PD:Value F10:Save ESC:Exit F1:General Help F5: Discard Changes F6:Standard Settings F7: Optimized Settings		

XBLUE- 78GA3/XBLUE- 78VA3

CMOS Setup Utility-Copyright(C)1985-2005 American Megatrends. Inc.

Thermal Throttling Options

CPU Thermal-Throttling	Enabled	Help Item
CPU Throttling Temp	70°C	Options
CPU Throttling Duty	50%	Disabled
		Enabled
↑↓← Move Enter:Select +/-/PU/PD:Value F10:Save ESC:Exit F1:General Help F5:Previous Values F6:Fail-Safe Defaults F7:Optimized Defaults		

CPU Thermal Throttling

Use this item to enable or disable CPU thermal Throttling. The optional settings are: Enable; Disabled. When set as Enabled, the two following items will show.

CPU Thermal Throttling Temp.

Use this item to set CPU thermal Throttling temperature. The selectable arrange is from 40 to 100 °C.

CPU Thermal Throttling Duty

Use this item to set CPU Thermal Throttling Duty. The selectable range is from: 12.5% to 87.5%.

3-12 Power User Overclock Setting

XBLUE- 77A3

CMOS Setup Utility-Copyright(C)1985-2005 American Megatrends. Inc.
Power User Overclock Setting

AMD Overclocking Configuration		Help Item
CPU/HT Reference Clock(MHz)	200	Enabled: only AMD over Disabled: Only BIO Ca
PCI E Reference Clock (MHz)	100	
SB Reference Clock(MHz)	100	
Processor Frequency Multiplier	Auto	
Over Voltage Configuration		
Processor Voltage	Auto	
AOD Compatibility	Disbled	
VDIMM Select	1.95 V	
NB Voltage Select	1.10V	
HT Link Speed	Auto	
HT Link Width	Auto	
DRAM Command Rate	2T	
Memory Clock Mode	Auto	
↑↓→← Move Enter:Select +/-/PU/PD:Value F10:Save ESC:Exit F1:General Help F5: Discard Changes F6:Standard Settings F7: Optimized Settings		

XBLUE- 78GA3/XBLUE- 78VA3

CMOS Setup Utility-Copyright(C)1985-2005 American Megatrends. Inc.
Power User Overclock Setting

AMD Overclocking Configuration		Help Item
CPU/HT Reference Clock(MHz)	200	
PCI E Reference Clock (MHz)	100	
SB Reference Clock(MHz)	100	
Spread Spectrum	Disabled	
Processor Frequency Multipli	Auto	
Processor Voltage	Auto	
Over Voltage Configuration		
Set Memory Voltage	1.95 V	
NB Voltage Setting	1.15V	
NODEQ PCI-X2 HT Link		
Link Speed	Auto	
Link Width	Auto	
DRAM Command Rate	2T	
Memory Clock Mode	Auto	
↑↓→← Move Enter:Select +/-/PU/PD:Value F10:Save ESC:Exit F1:General Help F5:Previous Values F6:Fail-Safe Defaults F7:Optimized Defaults		

CPU/HT Reference Clock

Use this item to set CPU/HT Reference Clock. The optional setting range is:190~400 MHz.

PCI E Reference Clock

The optional setting range is:90~250 MHz.

SB Reference Clock

The optional setting range is:90~150 MHz.

Spread Spectrum

The optional settings are: Disabled; SRC CLK; CPUHT CLK and All CLK.

Processor Voltage

The optional settings are: Auto; 0.800V~0.950V.

Set Memory Voltage/VDIMM Select

Use this item to set memory voltage.

NB-Core Voltage Setting

The optional settings are from 1.20v to 1.35v.

NB Voltage Setting/NB Voltage Select

This item is used for setting Northbridge voltage.

3-13 BIOS Security Features/ Password Settings

XBLUE- 77A3

CMOS Setup Utility-Copyright(C)1985-2005 American Megatrends. Inc.

BIOS Security Features

Security Settings	Help Item
Supervisor Password: Not Installed User Password: Not Installed Change Supervisor Password Press Enter Change User Password Press Enter Boot Sector Virus Protection Disabled	Install or change the password
↑↓→← Move Enter:Select +/-/PU/PD:Value F10:Save ESC:Exit F1:General Help F5: Discard Changes F6:Standard Settings F7: Optimized Settings	

XBLUE- 78GA3/XBLUE-78VA3

CMOS Setup Utility-Copyright(C)1985-2005 American Megatrends. Inc.

Password Setting

Security Settings	Help Item
Supervisor Password: Not Installed User Password: Not Installed Change Supervisor Password Press Enter Change User Password Press Enter Boot Sector Virus Protection Disabled	Install or change the password
↑↓→← Move Enter:Select +/-/PU/PD:Value F10:Save ESC:Exit F1:General Help F5:Previous Values F6:Fail-Safe Defaults F7:Optimized Defaults	

You can set either supervisor or user password, or both of them. The differences are:

Supervisor password: Can enter and change the options of the setup menus.

User password: Can only enter but do not have the right to change the options of the

setup menus. When you select this function, the following message will appear at the center of the screen to assist you in creating a password.

ENTER PASSWORD:

Type the password, up to eight characters in length, and press <Enter>. The password typed now will clear any previously entered password from CMOS memory. You will be asked to confirm the password. Type the password again and press <Enter>. You may also press <Esc> to abort the selection and not enter a password.

To disable a password, just press <Enter> when you are prompted to enter the password. A message will confirm that the password will be disabled. Once the password is disabled, the system will boot and you can enter Setup freely.

PASSWORD DISABLED.

When a password has been enabled, you will be prompted to enter it every time you try to enter Setup. This prevents an unauthorized person from changing any part of your system configuration.

Additionally, when a password is enabled, you can also require the BIOS to request a password every time your system is rebooted. This would prevent unauthorized use of your computer.

You determine when the password is required within the BIOS Features Setup Menu and its Security option. If the Security option is set to “System”, the password will be required both at boot and at entry to Setup. If set to “Setup”, prompting only occurs when trying to enter Setup.

Boot Sector Virus Protection

The selection Allow you to choose the VIRUS Warning

feature for IDE Hard Disk boot sector protection. If this function is enabled and someone attempt to write data into this area, BIOS will show a warning message on screen and alarm beep.

Disabled (default) No warning message to appear when anything attempts to access the boot sector or hard disk partition table.

Enabled Activates automatically when the system boots up causing a warning message to appear when anything attempts to access the boot sector of hard disk partition table.

3-14 Load Optimal/ Fail-Safe/Standard Defaults

Load Optimal Defaults

When you press <Enter> on this item, you get a confirmation dialog box with a message similar to:

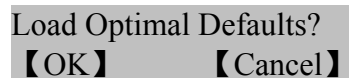

Load Optimal Defaults?
【OK】 【Cancel】

Pressing <OK> loads the default values that are factory settings for optimal performance system operations.

Load Fail-Safe Defaults

When you press <Enter> on this item, you get a confirmation dialog box with a message similar to:



Load Failsafe Defaults?
【OK】 【Cancel】

Pressing <OK> loads the Failsafe default values that are factory settings for stable performance system operations.

Load Standard Defaults

When you press <Enter> on this item, you get a confirmation dialog box with a message similar to:

Load Standard Defaults?
【OK】 【Cancel】

Pressing <OK> loads the standard default values that are factory settings for stable performance system operations.

3-15 Save Changes and Exit / Discard and Exit

Save Changes and Exit

When you press <Enter> on this item, you get a confirmation dialog box with a message similar to:

Save configuration changes and exit setup?
【OK】 【Cancel】

Pressing <OK> save the values you made previously and exit BIOS setup.

Discard and Exit

When you press <Enter> on this item, you get a confirmation dialog box with a message similar to:

Discard Changes and Exit Setup?
【OK】 【Cancel】

Pressing <OK> to leave BIOS setting without saving previously set values.

Notice!	The BIOS options in this manual are for reference only and BIOS menu in menus are usually the first BIOS version when the board is released. Users are welcome to download the latest BIOS version form our official website.
---------	---

Chapter 4

DRIVER & FREE PROGRAM INSTALLATION

Check your package and there is A MAGIC INSTALL CD included. This CD consists of all DRIVERS you need and some free application programs and utility programs. In addition, this CD also include an auto detect software which can tell you which hardware is installed, and which DRIVERS needed so that your system can function properly. We call this auto detect software MAGIC INSTALL.

MAGIC INSTALL supports WINDOWS 2000/XP/Vista

Insert CD into your CD-ROM drive and the MAGIC INSTALL Menu should appear as below. If the menu does not appear, double-click MY COMPUTER / double-click CD-ROM drive or click START / click RUN / type X:\SETUP.EXE (assuming X is your CD-ROM drive).



From MAGIC INSTALL MENU you may take 8 selections:

1. ATI install ATI driver pack
2. SOUND install ALC 662 HD Audio driver
3. LAN install RealTek LAN Controller Driver
4. RaidDisk install SATA RAID Driver and Utility
5. WIFI_N install RTL Wireless Network
6. WIFI_BG install RTL 8187 Wireless Network
7. Norton install Norton 2009 anti-virus program
8. PC-HEALTH install My Guard hardware monitor utility
9. BROWSE CD to browse the contents of the CD
10. EXIT to exit from MAGIC INSTALL menu

4-1 ATI Install ATI Driver Pack



1. Click ATI appears on the MAGIC INSTALL MENU.

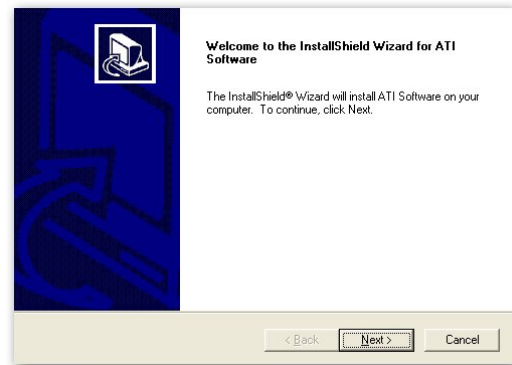

2. Click NEXT when ATI software driver pack appears.

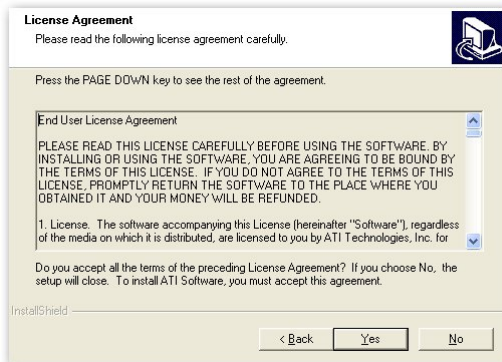

3. Click "Yes" to accept the license agreement and start installation.

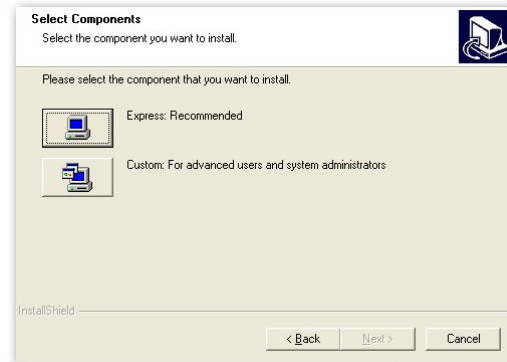

4. Choose whether you would like to restart and click Finish to restart your computer.



5. Click Continue anyway.



6. Choose Finish , do not restart your computer.

4-2 SOUND Install ALC662 HD Audio Driver

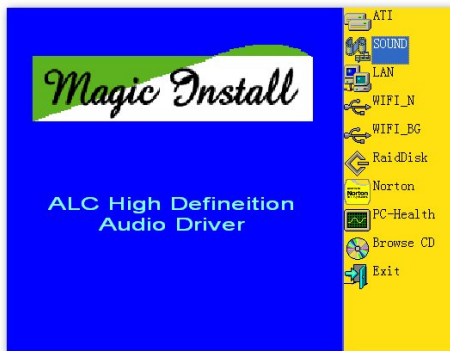

1. Click SOUND when MAGIC INSTALL MENU appears

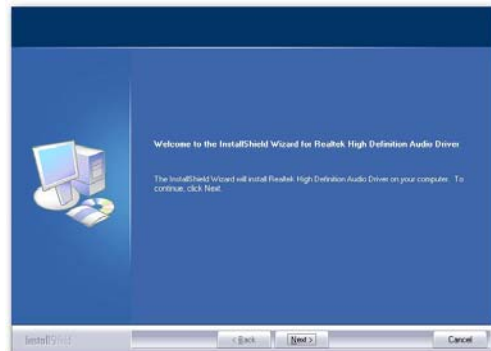

2. Click NEXT When Realtek High Definition Audio driver windows appear

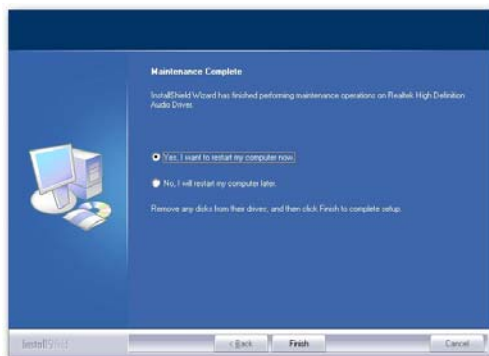

3. Click FINISH and restart your computer



4. Manual Sound Effect Setting



5. Devices and mixer setting



6. Audio input and output setting.



7. Microphone effect setting.



8. 3D demo setting.

NOTE: Please upgrade your Windows XP to Service Pack 1 / Windows 2000 to Service Pack 4

or later before you the HD Audio CODEC driver.

4-3 LAN Install RealTek LAN Controller Driver



1. Click LAN when Magic Install Menu appears.
2. Click Next to install RealTek LAN Driver.

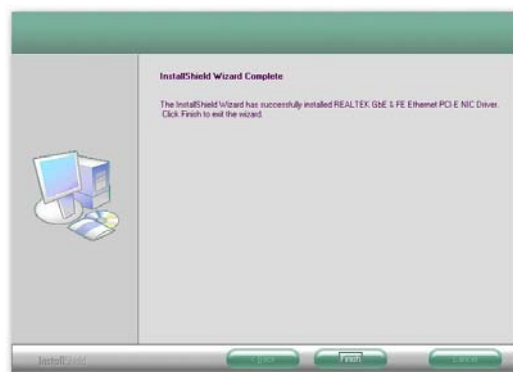
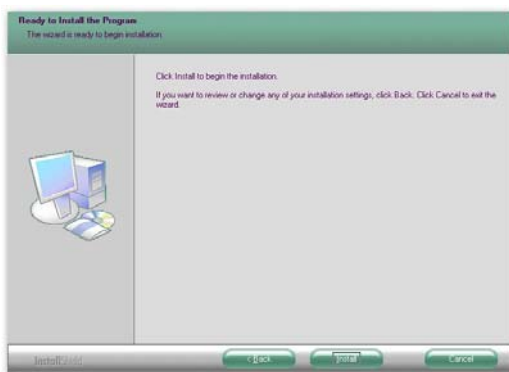

3. Click Install to begin the installation.
4. After driver installation completed, Click Finish.

4-4 WIFI_N Install RT2770 Wireless Network

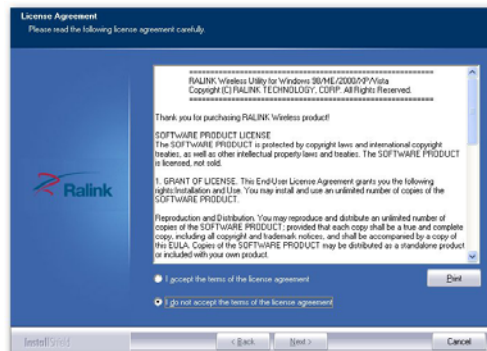

1. Click WIFI_N on Magic Install menu..
2. Click “I accept the terms of the license agreement” .

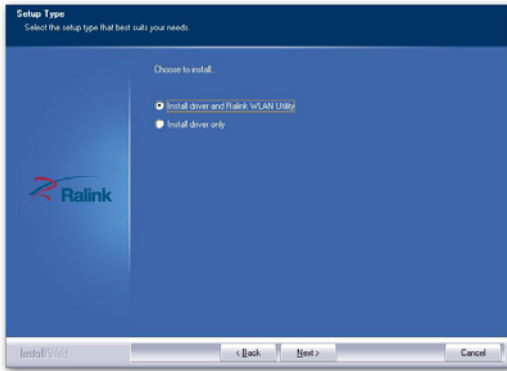

3. Select the setup type, then click Next.

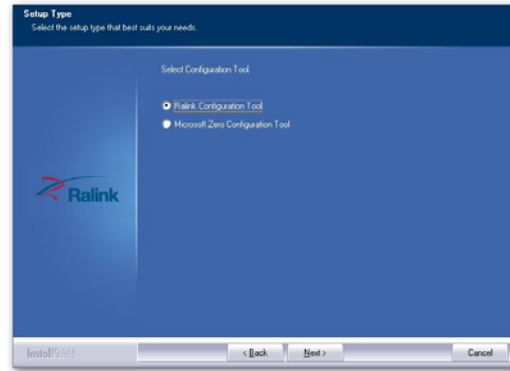

4. Select the configuration tool and then click Next.

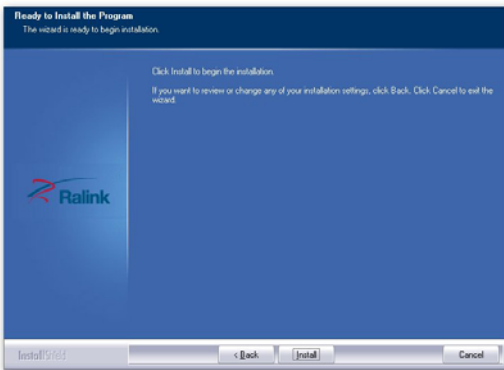

5. Click install to begin installation.



6. Click Finish to complete installation.

4-5 WIFI_BG Install RTL8187 Wireless Network



1. Click WIFI_BG on Magic Install menu..

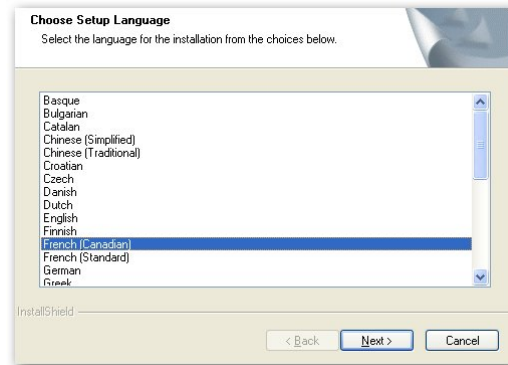

2. Choose setup language, then click Next.

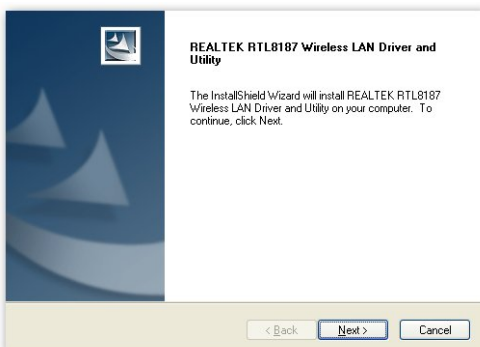

3. Click Next.

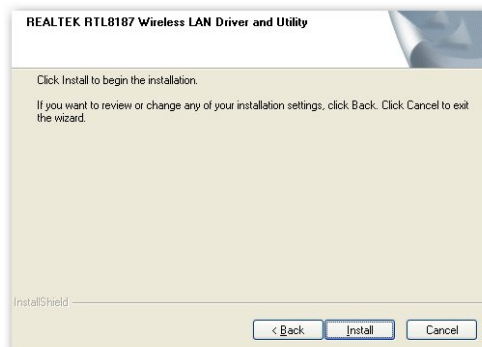

4. Click Install.

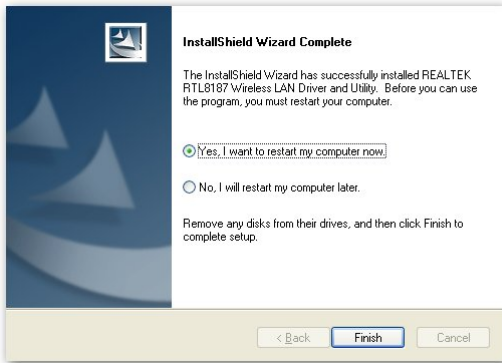

5. Decide if you wish to restart the computer then click Finish to complete the installation.

4-6 RAID Install SATA RAID Driver and Utility



1 Click RAIDDisk when MAGIC INSTALL MENU appears

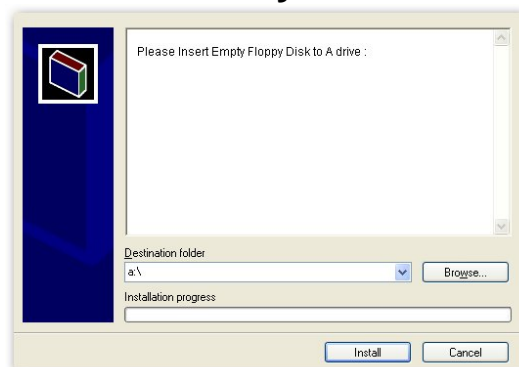

2. Copy the files to floppy disk and restart the computer with floppy disk as the first booting disk and then follow the steps shown on the screen to finish RAID function settings.

4-7 Norton Install Norton 2009 Anti-virus program



1 Click Norton when Magic Install menu appears.



2. Click AGREE & INSTALL after reading User License Agreement.

4-8 PC-HEALTH Install MyGuard Hardware Monitor Utility

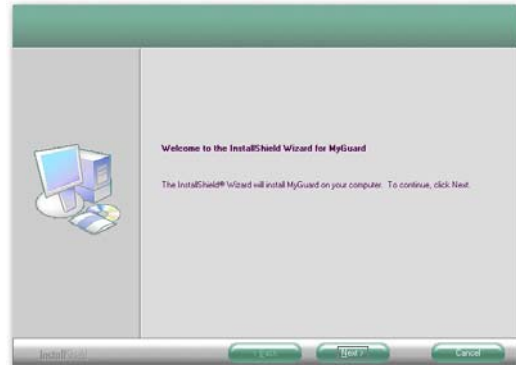

1. Click PC-HEALTH when MAGIC INSTALL MENU appears
2. Click Next on Install shield wizard Window appears.

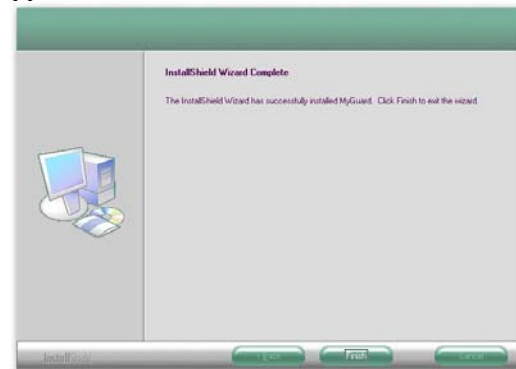
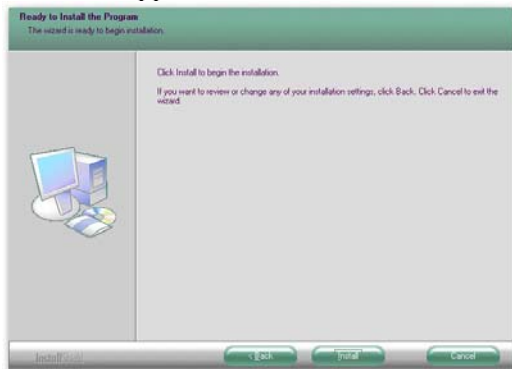

3. Click Install to begin the installation.
4. Click Finish to complete the installation.

4-9 How to Update BIOS

STEP 1. Prepare a bootable floppy disk. (You may make one by click START click RUN type SYS A: click OK)

STEP 2. Download upgrade tools and the latest BIOS files of the motherboard from official website and then make a copy of it to your bootable floppy disk after decompressing these files

STEP 3. Insert the disk into A: ,start your computer and then type in "A:\xxxxxx.BAT"(xxxxxxx being the file name of the latest BIOS)

STEP 4. Type Enter to update and flash the BIOS. The system will restart automatically when BIOS is upgraded.

4-10 AMD Platform RAID Function Installation

Please set these choice in the BIOS as RAID : BIOS setup \Integrated Peripherals \Onboard SATA Device \ Onchip SATA Type. When the below figures appeared, please press [Ctrl-F] into figure 2



[figure1]

Function: press[1] key, showing the RAID; press [2] key , building RAID; press [3] key, delete the RAID; press[4] key, showing the information of controller.

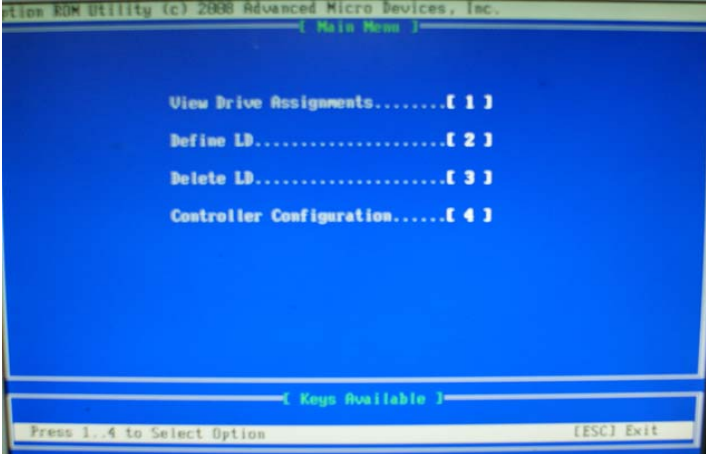

[figure2]

press[1] key , showing the RAID , as the below figure

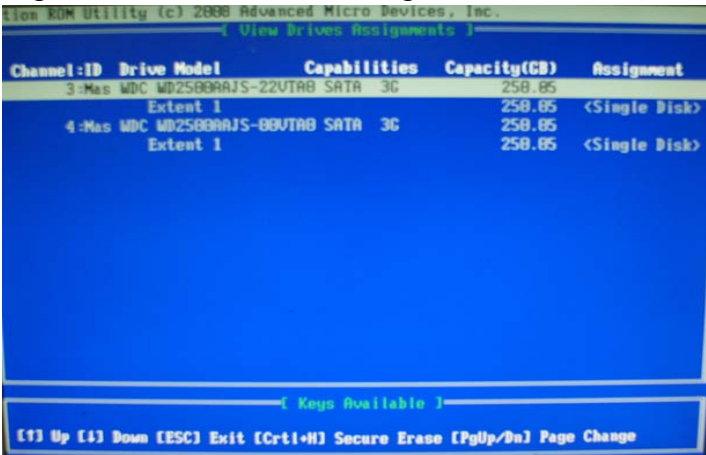

[figure3]

Press [2] key, the interface of RAID, as figure 4.

RAID function:

1. RAID 1 2. RAID 0 3. RAID 10 4. JBOD

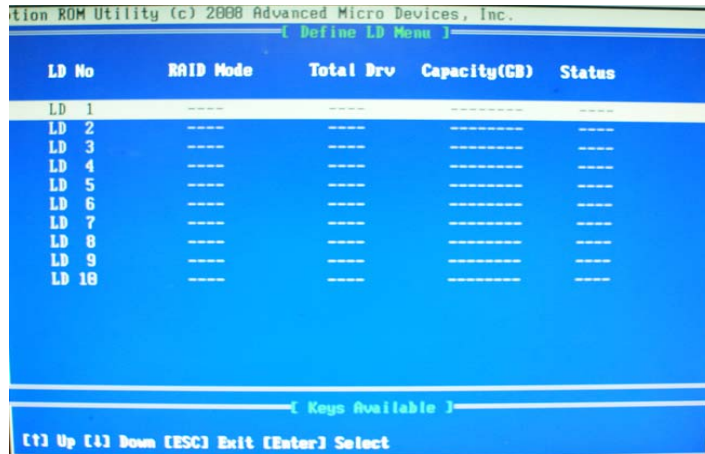

[figure4]

Choose LD 1 then press Enter.

Take Raid0 for example, use [↑] [↓] to shift the cursor, press space key to change the choice, press [Ctrl-Y] to keep.

Set Assignment mode as [Y], press [Ctrl-Y] to keep, then figure 5 appeared, erase the MBR. choose [Ctrl-Y], figure 6 appeared. Press any key, finished the RAID.

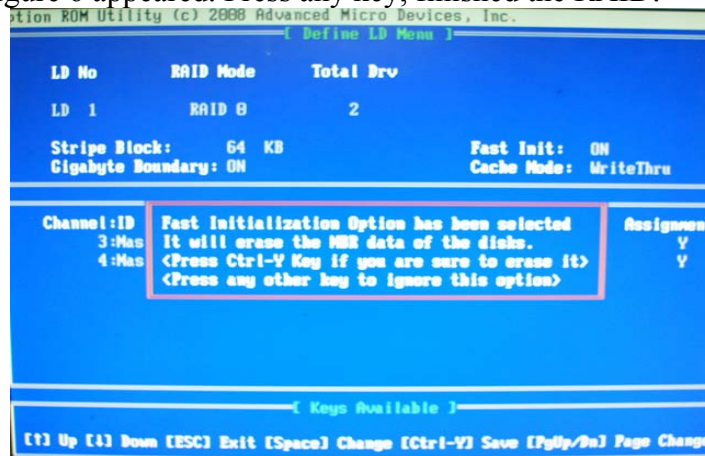

[figure5]

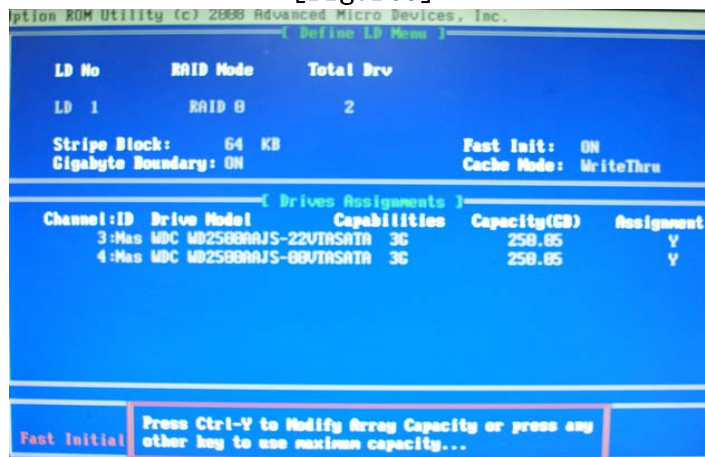

[figure6]

Press [3], delete the RAID mode, as figure 7. press [Delete] will delete the array. As figure 7 .

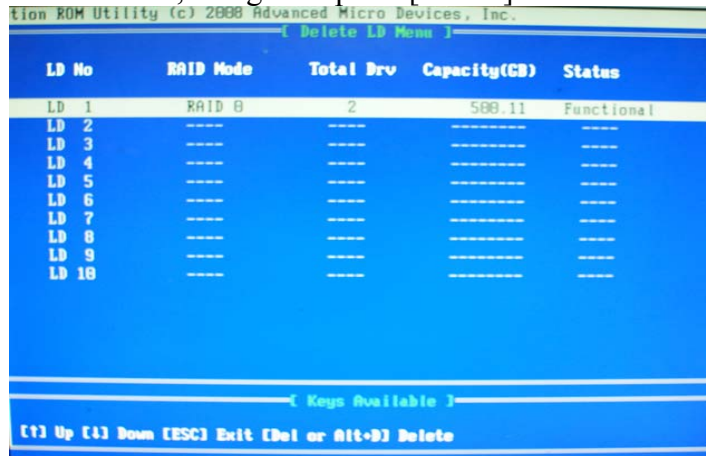

[figure7]

Press [4], showing the information of controller, as figure 8.

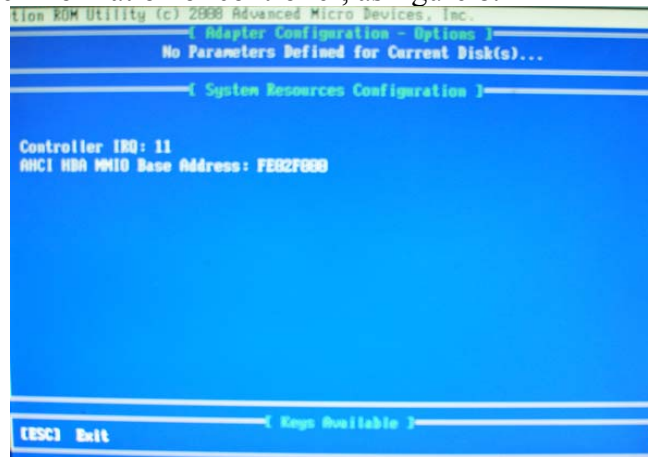

[figure8]

Making RAID driver diskette before Install [WindowsXP/2000/Vista](#)

Before you install the Windows XP or Windows 2000, you will need to make a RAID driver diskette before you start to install the Operating System.

How to make a RAID driver diskette?

- 1: Insert the diskette which is being formatted in floppy drive on a system which can start OS.
- 2: After booting OS insert the bundle CD in your CD-ROM
- 3: Copy all the files from [\AMD\RAIDDisk](#) to floppy diskette

Once you have the SATA driver diskette ready, you may start to install Windows XP, Windows 2000 or Vista on your System.

Installation of Windows XP/ 2000/Vista

For installation of Windows XP, windows 2000 or Vista, please insert Windows XP Windows 2000 or Vista CD into the CD-ROM drive. Then remove the floppy diskette, and boot the system. At the very beginning, you will see the message at the bottom of screen, "Press F6 if you need to install a third party SCSI or RAID driver...."

At this moment, please press <F6> key and follow the instructions of Windows XP or

Windows 2000 for the proper installation.

4-11 Pro Magic Plus Function Introduction

What's Pro Magic Plus?

Tired with reinstall OS each time when it doesn't work? Does your computer often crash down or unable to work after installed new software? Have you had great loses and troubles because of computer problems? Still using time-consuming backup software that occupies lots of HD space?

Pro Magic Plus- an instant system recovery software tailored to solve these problems for you. It combines various application tools (e.g. anti-virus, backup software, uninstall software, multi-boot software) to satisfy your needs of all sorts of system protections.

What functions does Pro Magic Plus have?

1. **Instant System Restoration** – Regardless of mis-operation or system crash, install Pro Magic Plus beforehand would allow you to instantly restore your system back by simply reboot your computer.
2. **Easy-to-use** – Auto installation from CD ROM; Supports Mouse
3. **System Uninstall** – Pro Magic provides a protection mode, which allows user to freely test any software. If user does not want to keep the software, just reboot the computer to restore back to the previous state, and Pro Magic will remove it completely from you computer.
4. **Password Security** – Pro Magic provides double password protection, including user password for entering each OS and manager password for managing 'Pro Magic', which can effectively prevent others from using your computer without permission or data from being stolen. (disable item for OEM version)
5. **Complete Protection** – Pro Magic not only protects the system disk, but also can protect your data disk, and does not require to reboot when backup or restore data disk.
6. **Multipoint Save/Restore** – You can backup your system whenever you need and restore them back to anytime you wish, 1 hour, 1 day or 1 month ago. Restore points are unlimited. (disable item for OEM version)
7. **Data Disk Protection** – Pro Magic Plus now comes with data disk protection, provides complete protection for your computer! (disable item for OEM version)
8. **You can choose to change the default path of 'My Document', 'My Favorite' and 'Outlook Express'**, so that when you are restoring the system, data in these folders will not be restored as well. (This is optional, you can leave it as it is).

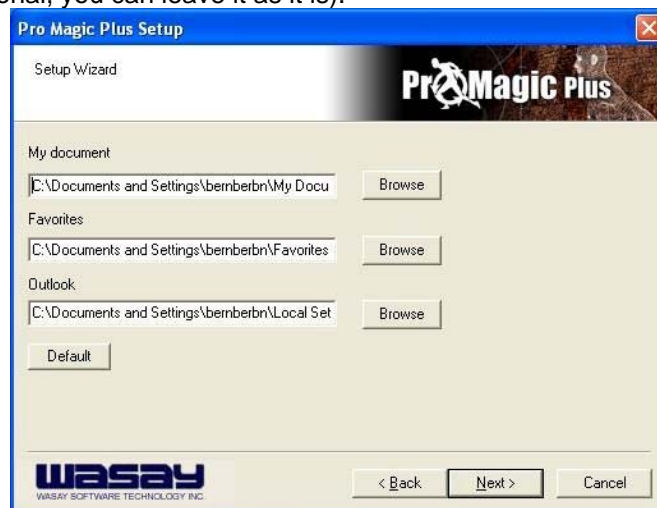

graph 4

☞ **NOTE:** Functions of each version will differ from each other, and will be based on the function descriptions of each version.

System Requirements

- ◇ First OS must be Windows 2000/XP/Vista

- ◇ Support Only Windows OS (No Linux)
- ◇ Windows server OS and Windows NT not supported
- ◇ Minimum of Intel 486 or above, 16MB of memory or above
- ◇ Minimum of 500MB free/usable space or above
- ◇ Support for SCSI & SATA Hard disk

Pro Magic Plus only supports SCSI hard disk with [Windows 2000 or OS above](#)

Notice Before Installation

1. Before install Pro Magic Plus, turn off all anti-virus software. (Include BIOS anti-virus function)
2. Pro Magic Plus does not support multiple PRI partitions. If you have multiple PRI partitions, please repartition your HD before installation.
3. If your HDD is not fully partitioned (with un-partitioned/unused space at end of HDD), please repartition the HDD before install Pro Magic Plus.

4-12 G.P.I Function Installation Steps

Operating Steps:

The Default setting in BIOS has already enabled this function. If you wish to change the settings, please enter BIOS and take the following steps:

Select: [Advanced BIOS Features](#)→[CPU Feature](#)→[AMD Cool&Quiet Control](#):
[AUTO/Disable](#)(This function control the POWER SAVING MODE: Auto/Disabled)

CMOS Setup Utility-Copyright(C)1985-2005 American Megatrends. Inc.

▶ Standard BIOS Features	▶ Thermal Throttling Option
▶ Advanced BIOS Features	▶ Power User Overclock Settings
▶ Advanced Chipset Features	▶ Password Settings
▶ Integrated Peripherals	Load Optimal Defaults
▶ Power Management Features	Load Fail-Safe Defaults
▶ Miscellaneous Control	Save & Exit Setup
▶ PC Health Status	Exit Without Saving
↑↓→←: Move Enter: Select +/-/: Value F10: Save ESC:Exit F1:General Help F7: Previous Values F8: Fail-Safe Defaults F9: Optimized Defaults	

[1]

Phoenix - AwardBIOS CMOS Setup Utility

Advanced BIOS Features

CPU Feature	Press Enter	
Hard Disk Boot Priority	Press Enter	Item Help
Virus Warning	Disabled	
CPU Internal Cache	Enabled	Menu Level >
External Cache	Enabled	
Quick power On Self Test	Enabled	
First Boot Device	Hard Disk	
Second Boot Device	CDROM	
Third Boot Device	Floppy	
Boot other Device	Enabled	
Boot Up Floppy Seek	Disable	
Boot Up NumLock Status	On	
Typematic Rate Setting	Disabled	
Typematic Rate (Chars/Sec)	6	
Typematic Delay (Msec)	250	
Security Option	Setup	
APIC Mode	Enabled	
MPS Version Control For OS	1.4	
OS Select For DRAM > 64MB	Non-OS2	
HDD S.M.A.R.T. Capability	Disabled	
Full Screen LOGO Show	Disabled	
↑↓→← Move Enter:Select +/-/PU/PD:Value F10:Save ESC:Exit F1:General Help F5:Previous Values F6:Optimized Defaults F7:Standard Defaults		

[2]

CMOS Setup Utility-Copyright(C)1985-2005 American Megatrends. Inc.

CPU Configuration

CPU Configuration	Help Item
Module Version: 13.43 AGESA Version: 3.3.3.0 Physical Count:1 Logical Count:2	This option should remain disabled for the normal operation. The driver developer may enable it for testing purposr
AMD Athlon(tm)64x2 Dual Core Processor 4200+ Revision :G2 Cache L1 : 256 KB Cache L2 :1024KB Cache L3 : N/A Speed : 2200 MHz, NV CLK: N/A Current FSB Multiplier : 11X Able to change Freq. : Yes uCode Path Level : None Required	
GART Error Reporting Disabled Microcode Update Enabled Secure Virtual Machine Mode Enabled Cool&Quiet Control Enabled CE1 Support Enabled ACPI SRAT Mode Enabled CPU Prefetching Enabled	
↑↓→←: Move Enter: Select +/-/: Value F10: Save ESC:Exit F1:General Help F5: Discard Changes F6:Fail-Safe Defaults F7: Optimal Defaults	

[3]

Compatible with OS: Windows XP/ 64 series. Users must install CPU driver program(AMD Processor Driver) and select the "Minimal"item in Power Setting.

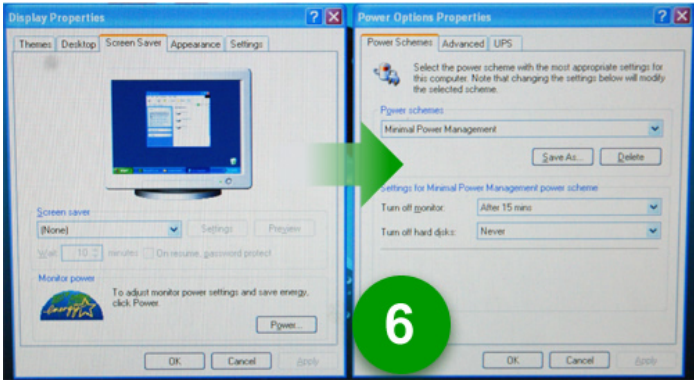
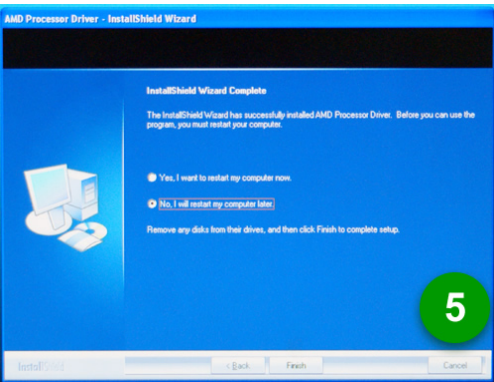
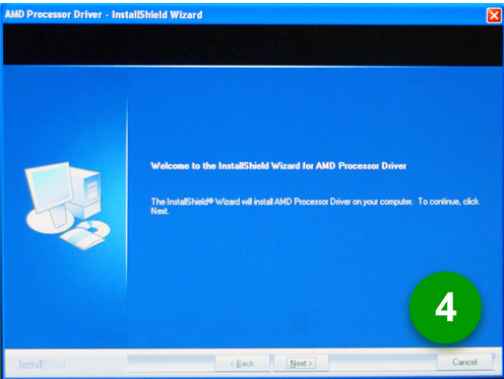

With OS Windows Vista series, there is no need for to take more steps. If needed, please enter Power Settings to make corresponding changes

4-13 G.P.I. LED Display



LED3

Light on-CPU workload is light and motherboard works in power-saving

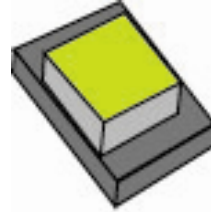

LED3

Light off-CPU workload is heavy and motherboard work in normal mold.

APPENDIX I

Subject 1: Regarding the Application of 3-Phase or 3+1 Phase Power Supply Mold



As a result of the increasing power consumption demand from many AMD CPUs in current market, we suggest not to use a CPU that demands more than 65W power consumption at work for an AMD CPU compliant board that comes with power supply design as 3 phase or 3+1 phase mold and MOSFET design as working in High SideX1 and Low SideX1 mold so as to avoid MOSFET getting burned or other phenomena like a halted system or system instability. So please take notice of the CPU you are using and make sure that it is one that demand not more than 65 W to ensure long-term working

order.

Note:

1. The relation between CPU Power Consumption Amount and Power Phase: depending on difference in voltage rating, one-phase of power can provide 25~30W to the motherboard.
2. 3- Phase Power Supply Mold: motherboard with 3 inductances for CPU power supply, and each inductance carries with it 2 MOSFET (6 MOSFETs in total) (Figure1)
3+1–Phase Power Supply Mold: motherboard with 4 inductances for CPU power supply, and each inductance carries with it 2 MOSFET (8 MOSFETs in total) (Figure2)

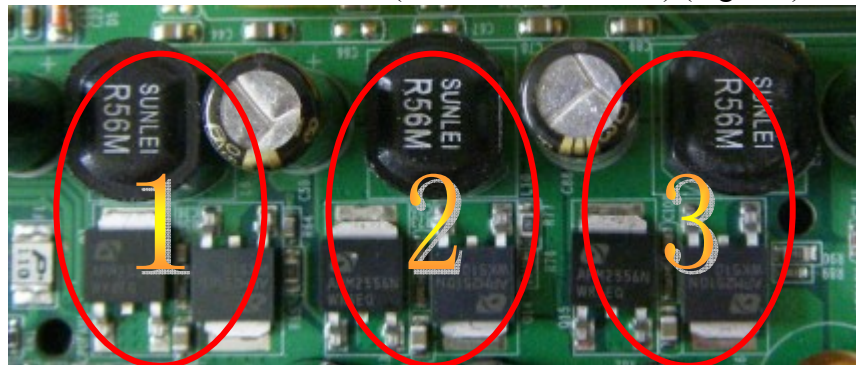

Figure 1

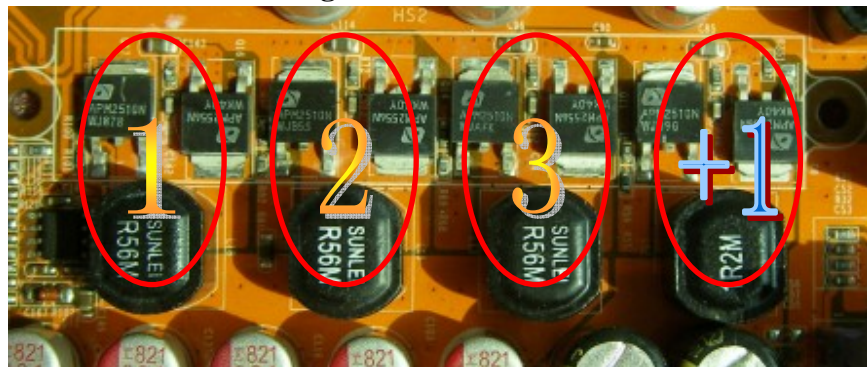

Figure 2

Solution:

We recommend users choose motherboards with power design of 4-phase, 4+1 phase or more for CPUs that demand 89W or 95W power consumption.

We recommend users choose motherboards with power design of 5-phase, 5+1 phase or more

for CPUs that demand 125W or 140W power consumption.

Subject 2: Suggestion on choosing electric fan



Both the amount of electric current to MOSFET and the heat produced from the motherboard go up as AMD's CPU power consumption increases. In this case we recommend users select a CPU fan with air outlet towards MOSFET so that CPU fan can carry away heat produced by MOSFET, for better heat dissipation effects. At the same time we suggest using well-ventilated cases to maintain temperature as 38°C approximately inside.(38°C is recommended by CPU manufactures)

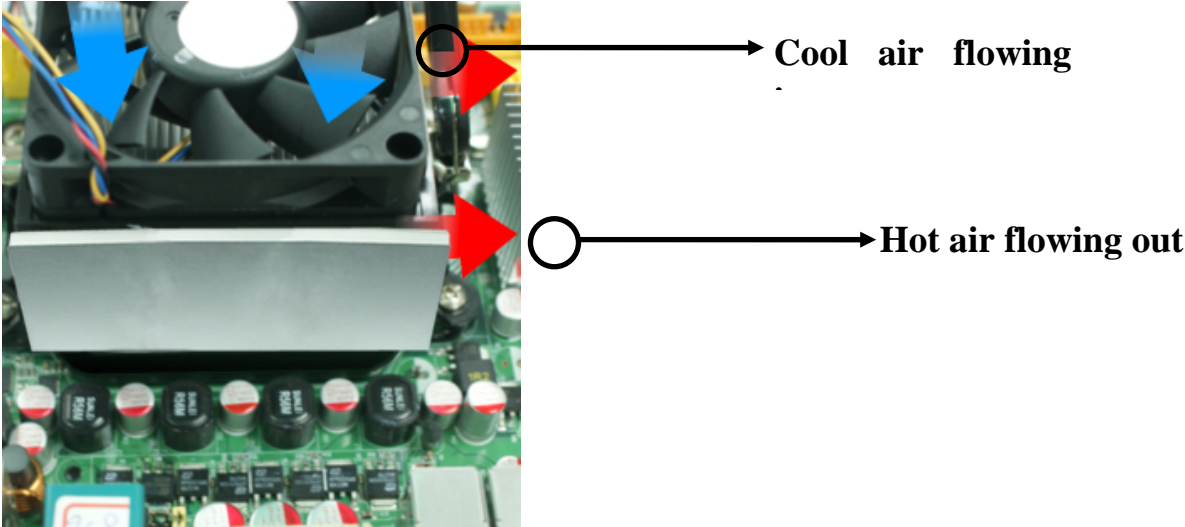

Figure 1---- CPU Fan can not blow off the heat produced by MOSFET. We suggest not to using fans of this kind

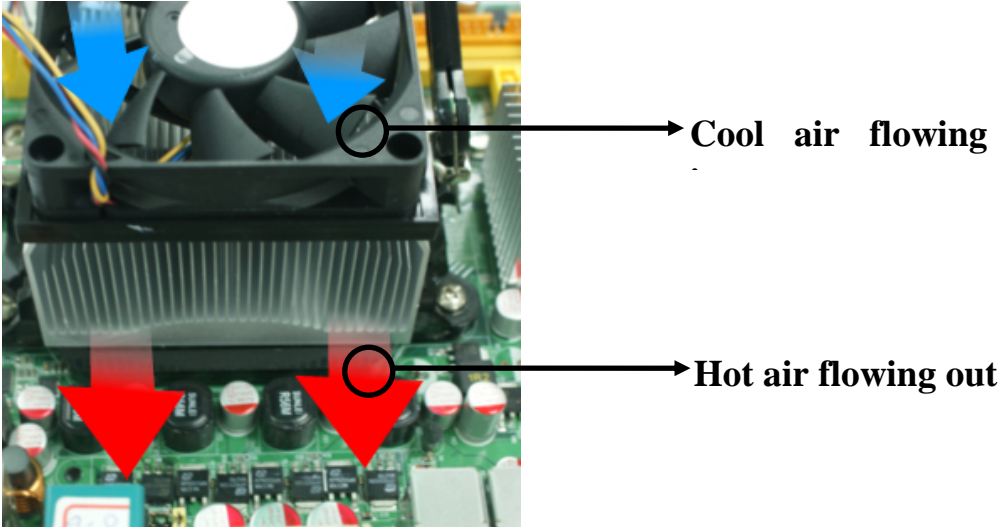

Figure 2---- CPU Fan can blow off the heat produced by MOSFET. We suggest using fans of this kind