

MODEL:

WAFER-PV-D5252/D4252/N4552

**3.5" SBC with Intel® Atom™ Processor
Up to 2.0 GB DDR3, VGA, LVDS, PCIe Mini, RS-232/422/485,
SATA 3Gb/s, CompactFlash®, Eight USB, RoHS**

User Manual

Revision

Date	Version	Changes
August 26, 2015	1.12	Updated Figure 1-3: Dimensions with Heatsink (mm) Updated Section 4.6: Chassis Installation
December 17, 2014	1.11	Added WAFER-PV-D4252 information
November 24, 2014	1.10	Updated for R11 version - Changed audio controller from ALC888 to ALC662 - Updated Chapter 5: BIOS
November 7, 2014	1.03	Modified COM port information to - RS-232 serial port: COM2~COM5 - RS-232/422/485 serial port: COM6
March 20, 2013	1.02	Modified supported memory specifications (Table 1-1)
March 4, 2011	1.01	Modified LVDS connector pinouts (Table 3-11) Modified LVDS resolution select jumper settings (Table 4-5)
January 11, 2011	1.00	Initial release

Copyright

COPYRIGHT NOTICE

The information in this document is subject to change without prior notice in order to improve reliability, design and function and does not represent a commitment on the part of the manufacturer.

In no event will the manufacturer be liable for direct, indirect, special, incidental, or consequential damages arising out of the use or inability to use the product or documentation, even if advised of the possibility of such damages.

This document contains proprietary information protected by copyright. All rights are reserved. No part of this manual may be reproduced by any mechanical, electronic, or other means in any form without prior written permission of the manufacturer.

TRADEMARKS

All registered trademarks and product names mentioned herein are used for identification purposes only and may be trademarks and/or registered trademarks of their respective owners.

Manual Conventions



WARNING

Warnings appear where overlooked details may cause damage to the equipment or result in personal injury. Warnings should be taken seriously.



CAUTION

Cautionary messages should be heeded to help reduce the chance of losing data or damaging the product.



NOTE

These messages inform the reader of essential but non-critical information. These messages should be read carefully as any directions or instructions contained therein can help avoid making mistakes.



HOT SURFACE

This symbol indicates a hot surface that should not be touched without taking care.

Table of Contents

1 INTRODUCTION.....	1
1.1 INTRODUCTION.....	2
1.2 BENEFITS	2
1.3 FEATURES.....	3
1.4 CONNECTORS	3
1.5 DIMENSIONS.....	4
1.6 DATA FLOW	6
1.7 TECHNICAL SPECIFICATIONS	7
2 PACKING LIST.....	9
2.1 ANTI-STATIC PRECAUTIONS	10
2.2 UNPACKING PRECAUTIONS.....	10
2.3 PACKING LIST.....	11
2.4 OPTIONAL ITEMS	12
3 CONNECTOR PINOUTS.....	13
3.1 PERIPHERAL INTERFACE CONNECTORS.....	14
3.1.1 <i>Layout</i>	14
3.1.2 <i>Peripheral Interface Connectors</i>	15
3.1.3 <i>External Interface Panel Connectors</i>	16
3.2 INTERNAL PERIPHERAL CONNECTORS	16
3.2.1 <i>ATX Power Connector</i>	16
3.2.2 <i>Audio Connector</i>	17
3.2.3 <i>Battery Connector</i>	18
3.2.4 <i>CompactFlash® Slot</i>	19
3.2.5 <i>Digital I/O Connector</i>	20
3.2.6 <i>Fan Connectors</i>	21
3.2.7 <i>Keyboard/Mouse Connector</i>	22
3.2.8 <i>LED and +5 V Power Output Connector</i>	23
3.2.9 <i>LVDS Connector</i>	24
3.2.10 <i>LVDS Backlight Connector</i>	25

3.2.11	<i>PCIe Mini Card Slot</i>	26
3.2.12	<i>Power Button Connector</i>	28
3.2.13	<i>Reset Button Connector</i>	28
3.2.14	<i>RS-232/422/485 Serial Port Connector (COM6)</i>	29
3.2.15	<i>RS-232 Serial Port Connector (COM2~COM5)</i>	30
3.2.16	<i>SATA Drive Connectors</i>	31
3.2.17	<i>SATA Power Connectors</i>	32
3.2.18	<i>SMBus Connector</i>	33
3.2.19	<i>SO-DIMM Connector</i>	33
3.2.20	<i>SPI Flash Connector</i>	34
3.2.21	<i>USB Connectors</i>	35
3.3	EXTERNAL INTERFACE CONNECTORS	36
3.3.1	<i>Ethernet Connectors</i>	36
3.3.2	<i>Serial Port Connector</i>	37
3.3.3	<i>USB Ports</i>	38
3.3.4	<i>VGA Connector</i>	38
4	INSTALLATION	40
4.1	ANTI-STATIC PRECAUTIONS	41
4.2	INSTALLATION CONSIDERATIONS	42
4.3	SO-DIMM INSTALLATION	43
4.4	COMPACTFLASH® INSTALLATION	44
4.5	JUMPER SETTINGS	45
4.5.1	<i>AT/ATX Mode Selection</i>	45
4.5.2	<i>Clear CMOS Jumper</i>	46
4.5.3	<i>LVDS Voltage Selection</i>	47
4.5.4	<i>LVDS Resolution Selection</i>	48
4.5.5	<i>CompactFlash® Master/Slave Selection</i>	49
4.5.6	<i>COM6 RS-232/422/485 Selection</i>	50
4.5.7	<i>COM 1 Pin 9 Setting Jumper</i>	51
4.6	CHASSIS INSTALLATION	52
4.6.1	<i>Heat Sink Enclosure</i>	52
4.6.2	<i>Motherboard Installation</i>	53
4.7	INTERNAL PERIPHERAL DEVICE CONNECTIONS	54
4.7.1	<i>AT Power Connection</i>	54

WAFER-PV-D5252/D4252/N4552 SBC

4.7.2 Audio Kit Installation.....	56
4.7.3 Keyboard/Mouse Connector	57
4.7.4 Four Serial Port Connector.....	58
4.8 SOFTWARE INSTALLATION	59
5 BIOS.....	61
5.1 INTRODUCTION.....	62
5.1.1 Starting Setup.....	62
5.1.2 Using Setup	62
5.1.3 Getting Help.....	63
5.1.4 Unable to Reboot After Configuration Changes.....	63
5.1.5 BIOS Menu Bar.....	63
5.2 MAIN.....	64
5.3 ADVANCED	65
5.3.1 ACPI Configuration	66
5.3.2 RTC Wake Settings	67
5.3.3 CPU Configuration.....	68
5.3.4 IDE Configuration	69
5.3.5 USB Configuration.....	71
5.3.6 Super IO Configuration	72
5.3.6.1 Serial Port n Configuration	73
5.3.7 H/W Monitor	78
5.3.8 Serial Port Console Redirection	79
5.3.9 IEI Feature.....	81
5.4 CHIPSET	82
5.4.1 Host Bridge	83
5.4.2 South Bridge.....	84
5.4.3 Intel IGD SWSCI OpRegion.....	86
5.5 BOOT.....	88
5.6 SECURITY.....	90
5.7 EXIT	90
A REGULATORY COMPLIANCE	92
B BIOS OPTIONS	94
C TERMINOLOGY	97

D DIGITAL I/O INTERFACE.....	101
D.1 INTRODUCTION.....	102
D.2 ASSEMBLY LANGUAGE SAMPLE 1.....	103
D.3 ASSEMBLY LANGUAGE SAMPLE 2.....	103
E HAZARDOUS MATERIALS DISCLOSURE	104
E.1 HAZARDOUS MATERIALS DISCLOSURE TABLE FOR IPB PRODUCTS CERTIFIED AS ROHS COMPLIANT UNDER 2002/95/EC WITHOUT MERCURY	105

List of Figures

Figure 1-1: WAFER-PV-D5252/D4252/N4552	2
Figure 1-2: Connectors	3
Figure 1-3: Dimensions with Heatsink (mm).....	5
Figure 1-4: Data Flow Diagram.....	6
Figure 3-1: Connector and Jumper Locations.....	14
Figure 3-2: ATX Power Connector Location	17
Figure 3-3: Audio Connector Location	17
Figure 3-4: Battery Connector Location.....	18
Figure 3-5: CompactFlash® Slot Location.....	19
Figure 3-6: Digital I/O Connector Location	21
Figure 3-7: Fan Connector Locations.....	22
Figure 3-8: Keyboard/Mouse Connector Location	23
Figure 3-9: LED and +5 V Power Output Connector Location	24
Figure 3-10: LVDS Connector Location.....	25
Figure 3-11: Backlight Inverter Connector.....	26
Figure 3-12: PCIe Mini Card Slot Location.....	27
Figure 3-13: Power Button Connector Location.....	28
Figure 3-14: Reset Button Connector Location.....	29
Figure 3-15: RS-232/422/485 Serial Port Connector Location.....	29
Figure 3-16: RS-232 Serial Port Connector Location.....	30
Figure 3-17: SATA Drive Connector Location	31
Figure 3-18: SATA Power Connector Locations	32
Figure 3-19: SMBus Connector Location	33
Figure 3-20: SO-DIMM Connector Location	34
Figure 3-21: SPI Flash Connector Location.....	34
Figure 3-22: USB Connector Location.....	35
Figure 3-23: External Interface Connectors.....	36
Figure 3-24: Ethernet Connector.....	37
Figure 3-25: Serial Port Pinout Locations	38
Figure 3-26: VGA Connector	39

Figure 4-1: SO-DIMM Installation	43
Figure 4-2: CompactFlash® Card Installation	44
Figure 4-3: AT/ATX Mode Selection Jumper Location.....	46
Figure 4-4: Clear CMOS Jumper Location	47
Figure 4-5: LVDS Voltage Selection Jumper Location	48
Figure 4-6: LVDS Resolution Selection Jumper Location.....	49
Figure 4-7: CompactFlash® Master/Slave Selection Jumper Location	50
Figure 4-8: COM6 RS-232/422/485 Selection Jumper Location	50
Figure 4-9: COM 1 Pin 9 Setting Jumper Location.....	51
Figure 4-10: Heat Sink Retention Screws	52
Figure 4-11: Motherboard Installation Example	53
Figure 4-12: Power Cable to Motherboard Connection	55
Figure 4-13: Connect Power Cable to Power Supply.....	55
Figure 4-14: Audio Kit Cable Connection	56
Figure 4-15: Keyboard/mouse Y-cable Connection	57
Figure 4-16: Four Serial Port Connector	58
Figure 4-17: Serial Device Connector.....	59
Figure 4-18: Introduction Screen	60
Figure 4-19: Available Drivers	60

List of Tables

Table 1-1: Technical Specifications.....	8
Table 2-1: Packing List.....	12
Table 2-2: Optional Items.....	12
Table 3-1: Peripheral Interface Connectors.....	16
Table 3-2: Rear Panel Connectors.....	16
Table 3-3: ATX Power Connector Pinouts.....	17
Table 3-4: Audio Connector Pinouts.....	18
Table 3-5: Battery Connector Pinouts.....	18
Table 3-6: CompactFlash® Slot Pinouts.....	20
Table 3-7: Digital I/O Connector Pinouts.....	21
Table 3-8: Fan Connector Pinouts.....	22
Table 3-9: Keyboard/Mouse Connector Pinouts.....	23
Table 3-10: LED and +5 V Power Output Connector Pinouts.....	24
Table 3-11: LVDS Connector Pinouts.....	25
Table 3-12: Backlight Inverter Connector.....	26
Table 3-13: PCIe Mini Card Slot Pinouts.....	28
Table 3-14: Power Button Connector Pinouts.....	28
Table 3-15: Reset Button Connector Pinouts.....	29
Table 3-16: RS-232/422/485 Serial Port Connector Pinouts.....	30
Table 3-17: Serial Port Connector Pinouts.....	31
Table 3-18: SATA Drive Connector Pinouts.....	32
Table 3-19: SATA Power Connector Pinouts.....	32
Table 3-20: SMBus Connector Pinouts.....	33
Table 3-21: SPI Flash Connector Pinouts.....	34
Table 3-22: USB Port Connector Pinouts.....	35
Table 3-23: Ethernet Connector Pinouts.....	36
Table 3-24: RJ-45 Ethernet Connector LEDs.....	37
Table 3-25: Serial Port Pinouts.....	37
Table 3-26: USB Connector Pinouts.....	38
Table 3-27: VGA Connector Pinouts.....	39

Table 4-1: Jumpers	45
Table 4-2: AT/ATX Mode Selection	46
Table 4-3: Clear CMOS Jumper Settings.....	47
Table 4-4: LVDS Voltage Selection	48
Table 4-5: LVDS Resolution Selection.....	48
Table 4-6: CompactFlash® Master/Slave Selection	49
Table 4-7: COM6 RS-232/422/485 Selection	50
Table 4-8: COM 1 Pin 9 Setting Jumper Settings	51
Table 5-1: BIOS Navigation Keys	63

BIOS Menus

BIOS Menu 1: Main	64
BIOS Menu 2: Advanced	65
BIOS Menu 3: ACPI Configuration	66
BIOS Menu 4: RTC Wake Settings	67
BIOS Menu 5: CPU Configuration	68
BIOS Menu 6: IDE Configuration	69
BIOS Menu 7: USB Configuration	71
BIOS Menu 8: Super IO Configuration.....	72
BIOS Menu 9: Serial Port n Configuration Menu	73
BIOS Menu 10: Hardware Health Configuration	78
BIOS Menu 11: Serial Port Console Redirection	80
BIOS Menu 12: IEI Feature	81
BIOS Menu 13: Chipset	82
BIOS Menu 14:Host Bridge Configuration	83
BIOS Menu 15:Southbridge Chipset Configuration	84
BIOS Menu 16: Intel IGD SWSCI OpRegion	86
BIOS Menu 17: Boot	88
BIOS Menu 18: Security	90
BIOS Menu 19:Exit.....	91

Chapter

1

Introduction

1.1 Introduction

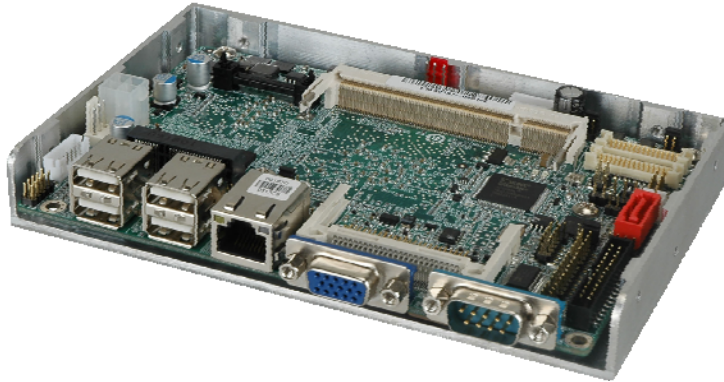

Figure 1-1: WAFER-PV-D5252/D4252/N4552

The WAFER-PV-D5252/D4252/N4552 is a 3.5" SBC with a Intel® Atom™ D525, D425 or N455 CPU.

The WAFER-PV-D5252/D4252/N4552 is designed for fanless operation. The low power CPUs don't require active cooling and stay within specified heat range using the included heatsink.

Storage on the board is handled by a SATA 3Gb/s port for connecting a hard drive, optical drive or SSD. The CompactFlash® slot allows a Type II CompactFlash® card to be installed.

The board has two graphics outputs. A VGA output connects to a traditional VGA monitor and one LVDS connector supports 18-bit single-channel display.

Other slots and connectors include a PCIe Mini cards slot, RS-232, RS-232/422/485, Gigabit Ethernet, USB ports, and digital I/O.

1.2 Benefits

Some of the WAFER-PV-D5252/D4252/N4552 motherboard benefits include:

- Low power consumption
- Wide range of I/O interfaces
- Dual display support

WAFER-PV-D5252/D4252/N4552 SBC

1.3 Features

Some of the WAFER-PV-D5252/D4252/N4552 motherboard features are listed below:

- 3.5" form factor
- Fanless design
- RoHS compliant
- Eight USB 2.0 ports
- Six serial ports
- PCIe Mini card slot
- CompactFlash® Type II slot
- Gigabit Ethernet

1.4 Connectors

The connectors on the WAFER-PV-D5252/D4252/N4552 are shown in the figure below.

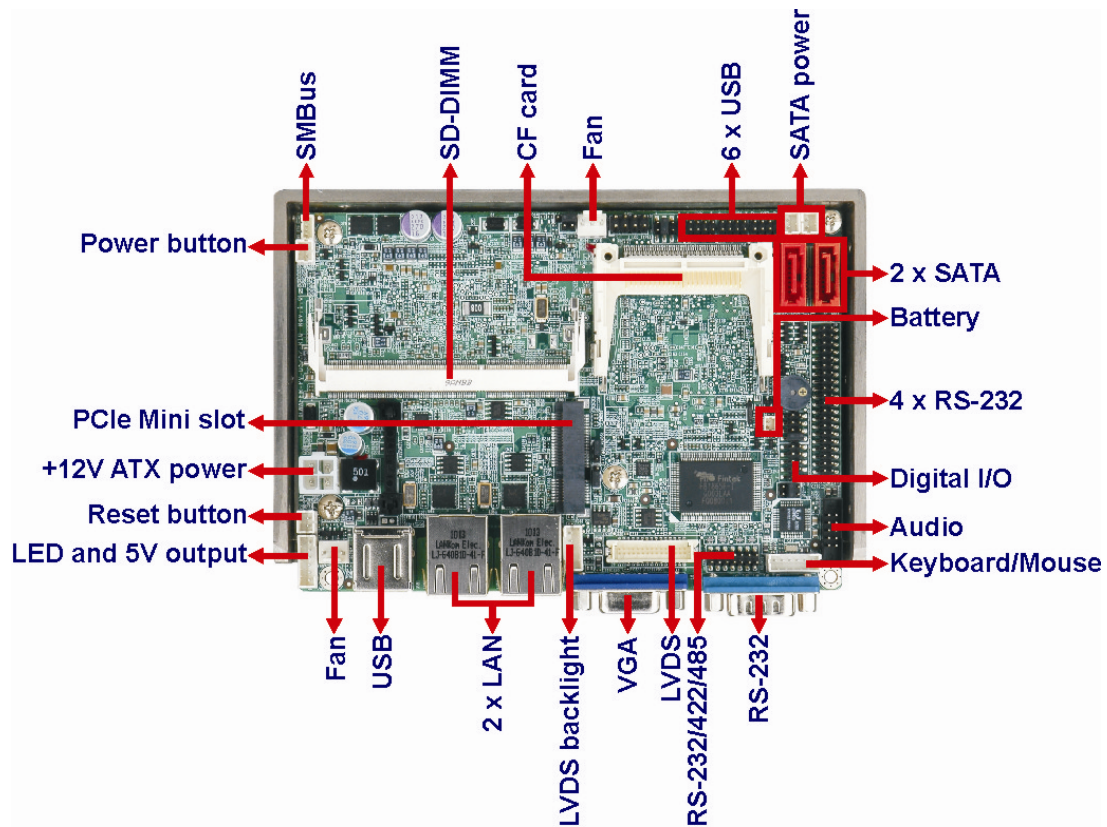
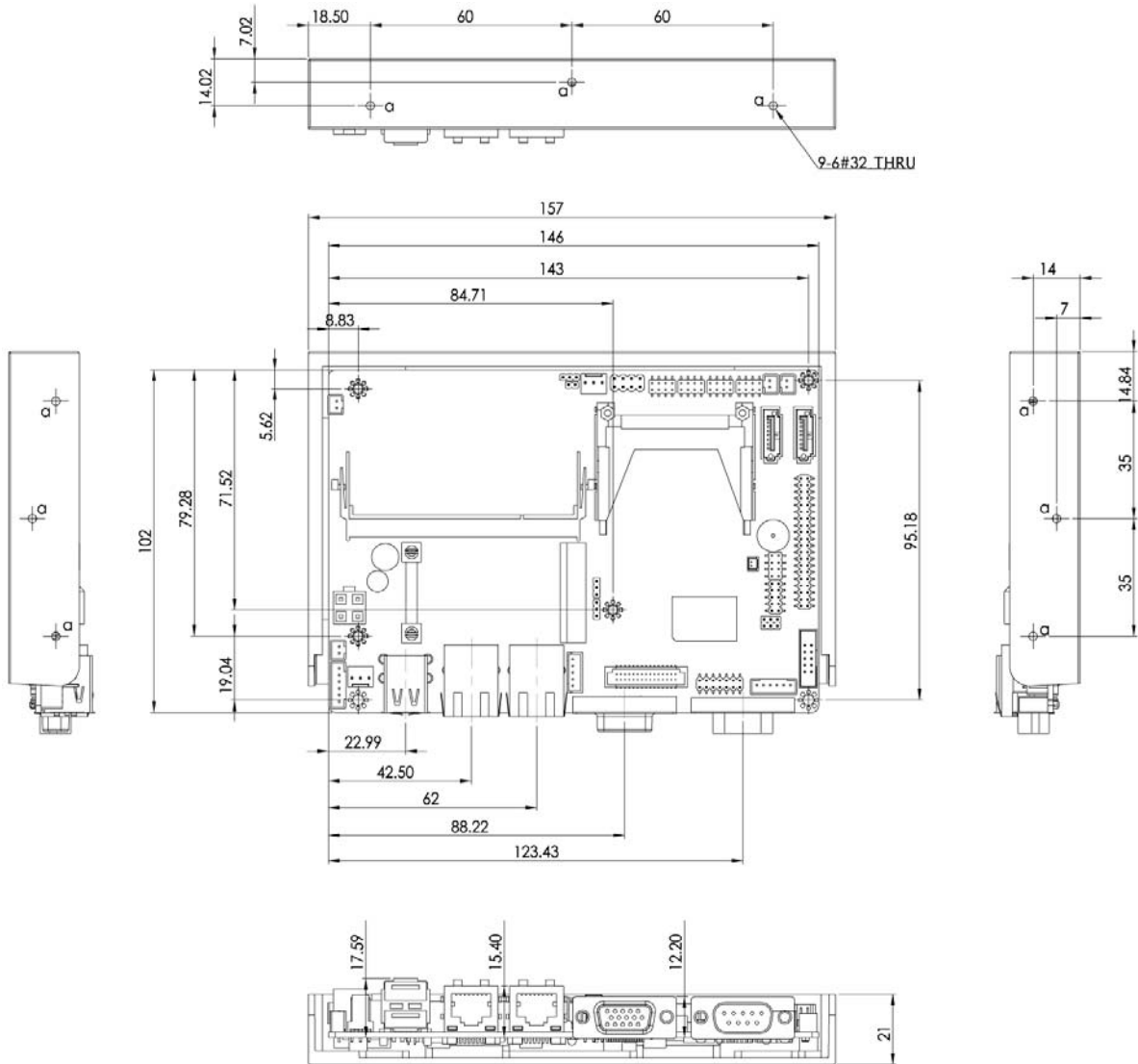

Figure 1-2: Connectors

1.5 Dimensions

The main dimensions of the WAFER-PV-D5252/D4252/N4552 are shown in the diagram below.



WAFER-PV-D5252/D4252/N4552 SBC

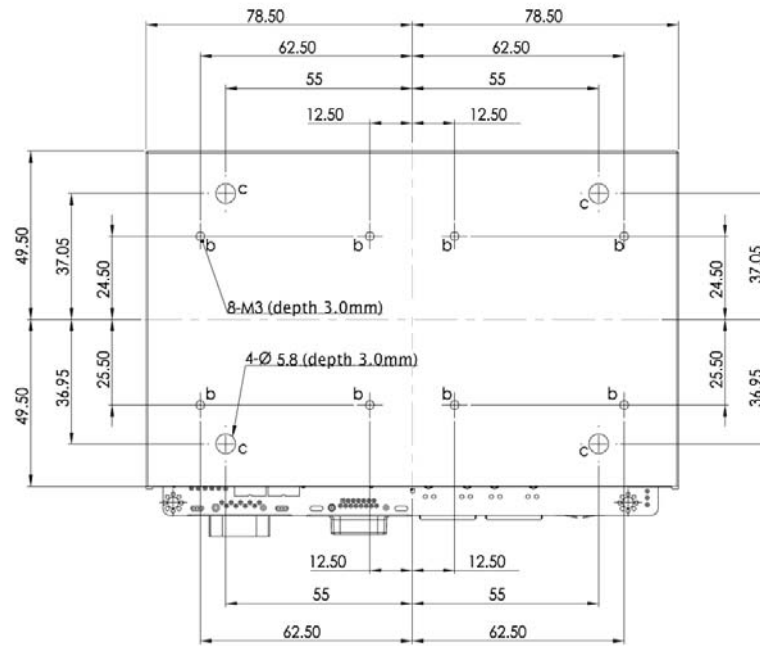

Figure 1-3: Dimensions with Heatsink (mm)

1.6 Data Flow

Figure 1-4 shows the data flow between the system chipset, the CPU and other components installed on the motherboard.

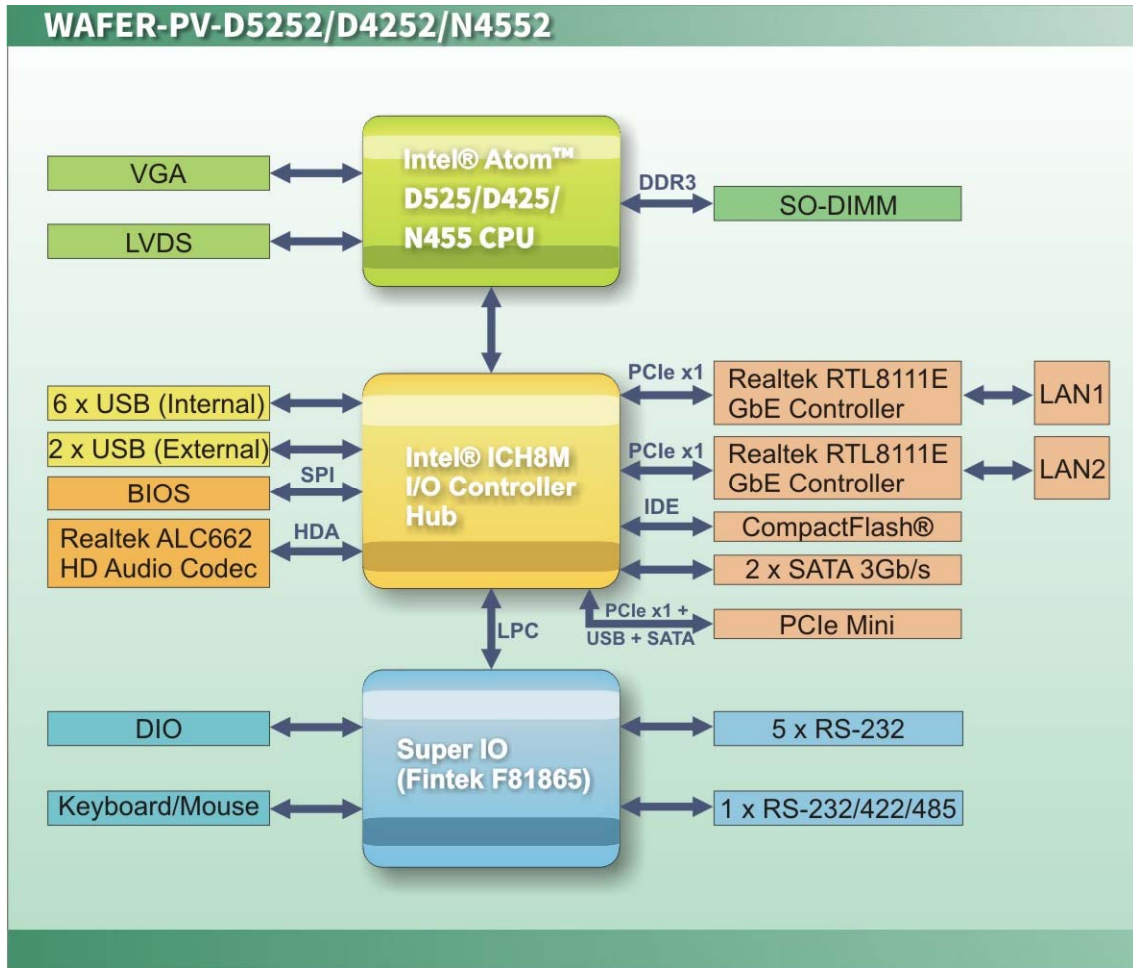

Figure 1-4: Data Flow Diagram

WAFER-PV-D5252/D4252/N4552 SBC

1.7 Technical Specifications

WAFER-PV-D5252/D4252/N4552 technical specifications are listed in Table 1-1.

Specification	WAFER-PV-D5252/D4252/N4552
Form Factor	3.5"
Socket	Embedded
CPU Supported	1.8 GHz Intel® Atom™ D525 dual-core CPU with 1 MB L2 cache 1.8 GHz Intel® Atom™ D425 single-core CPU with 512 KB L2 cache 1.66 GHz Intel® Atom™ N455 single-core CPU with 512 KB L2 cache
System Chipset	Intel® ICH8M
Memory	One 204-pin 800 MHz DDR3 SDRAM SO-DIMM <ul style="list-style-type: none"> ▪ D525/D425: system max. 4.0 GB ▪ N455: system max. 2.0 GB
Graphic Engine	Intel® GMA3150 <ul style="list-style-type: none"> ▪ D525/D425: Gen 3.5 DX9, 400 MHz ▪ N455: Gen 3.5 DX9, 200 MHz
Integrated Graphics	Analog CRT (CRT hot plug supported) <ul style="list-style-type: none"> ▪ D525/D425: up to 2048 x 1536 ▪ N455: up to 1400 x 1050 18-bit single-channel LVDS
BIOS	UEFI BIOS
Digital I/O	8-bit, 4-bit input/4-bit output
Ethernet Controllers	Two Realtek RTL8111E PCIe GbE controllers (LAN1 supports ASF2.0)
Audio	Realtek ALC662 HD Audio codec
Super I/O Controller	Fintek F81865F
Watchdog Timer	Software programmable supports 1~255 sec. system reset
Expansion	PCIe Mini slot (PCIe + USB + SATA signal) supports IEI PCIe Mini disk on module (DOM) cards

I/O Interface Connectors	
Fan connector	Two 3-pin wafer for system fan
Keyboard/Mouse	One internal 6-pin wafer connector
Serial Ports	Five RS-232 COM connectors One RS-232/422/485 COM connector
USB 2.0/1.1 ports	Six internal via pin header Two external USB ports
SMBus	One 4-pin wafer connector
Storage	
IDE	CompactFlash® Type II slot
SATA	Two independent SATA channels with 3.0 Gb/s data transfer rates
Environmental and Power Specifications	
Power Supply	AT or ATX, 12 V only
Power Consumption	12 V @ 1.79 A (1.8 GHz Intel® Atom™ D525 dual-core CPU with one 1 GB DDR3 SO-DIMM)
Operating temperature	D525: -20°C ~ 60°C with free air; -20°C ~ 70°C with force air D425: -20°C ~ 65°C with free air; -20°C ~ 70°C with force air N455: -20°C ~ 70°C with free air; -20°C ~ 75°C with force air
Humidity	0% ~ 95% (non-condensing)
Physical Specifications	
Dimensions	102 mm x 146 mm
Weight GW/NW	600 g/250 g

Table 1-1: Technical Specifications

Chapter

2

Packing List

2.1 Anti-static Precautions



WARNING!

Static electricity can destroy certain electronics. Make sure to follow the ESD precautions to prevent damage to the product, and injury to the user.

Make sure to adhere to the following guidelines:

- **Wear an anti-static wristband:** Wearing an anti-static wristband can prevent electrostatic discharge.
- **Self-grounding:** Touch a grounded conductor every few minutes to discharge any excess static buildup.
- **Use an anti-static pad:** When configuring any circuit board, place it on an anti-static mat.
- **Only handle the edges of the PCB:** Don't touch the surface of the motherboard. Hold the motherboard by the edges when handling.

2.2 Unpacking Precautions

When the WAFER-PV-D5252/D4252/N4552 is unpacked, please do the following:

- Follow the antistatic guidelines above.
- Make sure the packing box is facing upwards when opening.
- Make sure all the packing list items are present.

WAFER-PV-D5252/D4252/N4552 SBC







2.3 Packing List



NOTE:

If any of the components listed in the checklist below are missing, do not proceed with the installation. Contact the IEI reseller or vendor the WAFER-PV-D5252/D4252/N4552 was purchased from or contact an IEI sales representative directly by sending an email to sales@ieiworld.com.

The WAFER-PV-D5252/D4252/N4552 is shipped with the following components:

Quantity	Item and Part Number	Image
1	WAFER-PV-D5252, WAFER-PV-D4252 or WAFER-PV-N4552	
1	SATA and power cable (P/N: 32801-000201-100-RS)	
1	Quad COM port cable (wo bracket) (P/N: 32200-025401-RS)	
1	KB/MS PS/2 Y-cable (P/N: 32000-023800-RS)	
1	AT 12 V cable (P/N: 32100-087100-RS)	
1	Audio cable (P/N: 32000-072100-RS)	





Quantity	Item and Part Number	Image
1	Mini jumper pack (2.0mm) (P/N:33100-000033-RS)	
1	Utility CD	
	One Key Recovery CD	
1	Quick installation guide	

Table 2-1: Packing List

2.4 Optional Items

These optional items are available.



Item and Part Number	Image
Dual USB cable (wo bracket) (P/N: 32000-070301-RS)	
RS-232/422/485 cable (P/N: 32200-026500-RS)	

Table 2-2: Optional Items

Chapter

3

Connector Pinouts

3.1 Peripheral Interface Connectors

Section 3.1.2 shows peripheral interface connector locations. Section 3.1.2 lists all the peripheral interface connectors seen in Section 3.1.2.

3.1.1 Layout

The figure below shows the on-board peripheral connectors, rear panel peripheral connectors and on-board jumpers.

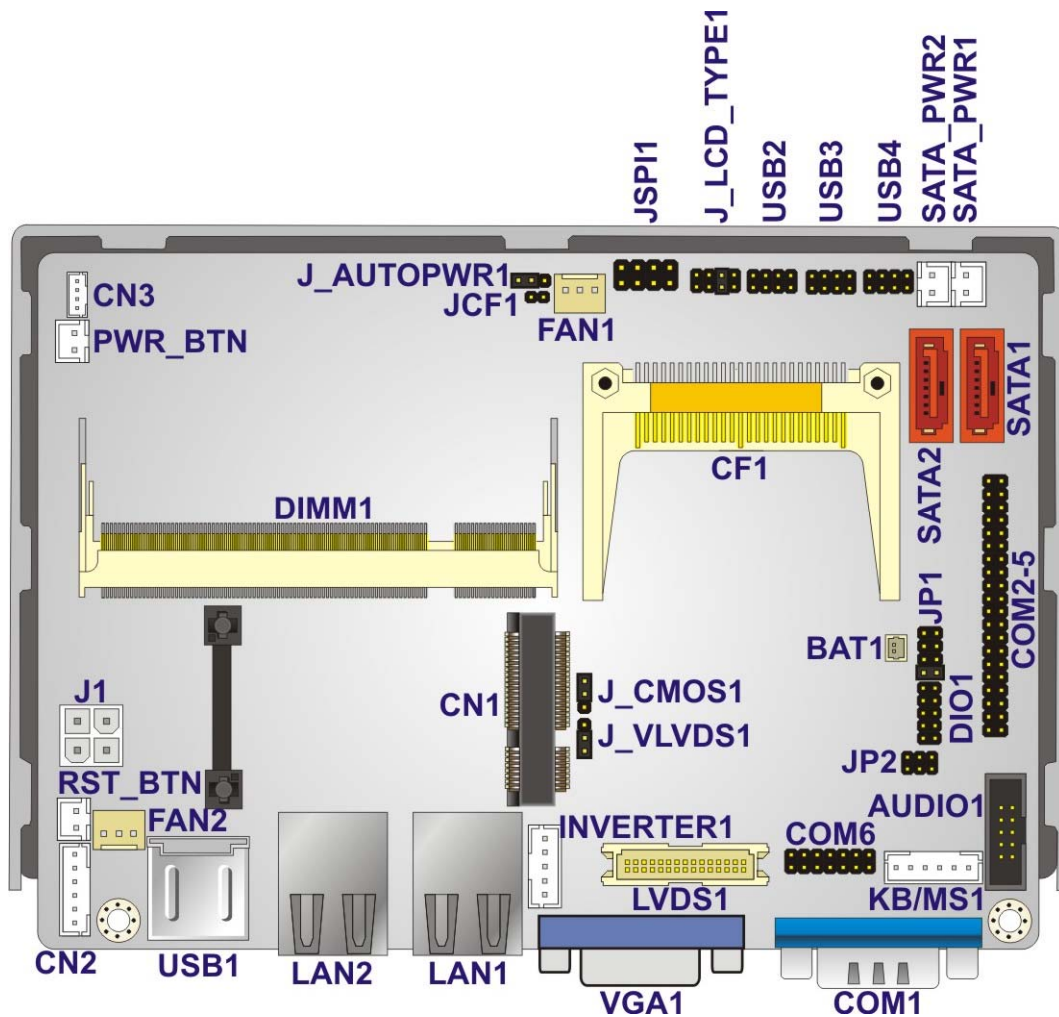

Figure 3-1: Connector and Jumper Locations

WAFER-PV-D5252/D4252/N4552 SBC

3.1.2 Peripheral Interface Connectors

The table below shows a list of the peripheral interface connectors on the WAFER-PV-D5252/D4252/N4552. Detailed descriptions of these connectors can be found below.

Connector	Type	Label
+12 V ATX power connector	4-pin connector	J1
Audio connector	10-pin box header	AUDIO1
Battery connector	2-pin wafer	BT1
CompactFlash® card slot	CF card slot	CF1
Digital I/O connector	10-pin header	DIO1
Fan connectors	3-pin wafer	FAN1, FAN2
Keyboard/mouse connector	6-pin wafer	KB/MS1
LED indicators and 5 V power output connector	6-pin wafer	CN2
LVDS connector	30-pin crimp	LVDS1
LVDS backlight connector	5-pin box header	INVERTER1
PCIe Mini card slot	PCIe Mini card slot	CN1
Power button connector	2-pin wafer	PWR_BTN
Reset button connector	2-pin wafer	RST_BTN
RS-232 serial port (COM2~COM5)	40-pin header	COM2-5
RS-232/422/485 serial port (COM6)	14-pin header	COM6
SATA connectors	SATA connector	SATA1, SATA2
SATA power connectors	2-pin wafer	SATA_PWR1 SATA_PWR2
SMBus connector	4-pin wafer	CN3
SO-DIMM connector	SO-DIMM connector	DIMM1
SPI Flash	8-pin header	JSPI1

Connector	Type	Label
USB connectors	8-pin header	USB2, USB3, USB4

Table 3-1: Peripheral Interface Connectors

3.1.3 External Interface Panel Connectors

The table below lists the rear panel connectors on the WAFER-PV-D5252/D4252/N4552. Detailed descriptions of these connectors can be found in a later section.

Connector	Type	Label
USB connectors	Dual-USB	USB1
LAN connectors	RJ-45	LAN1, LAN2
Serial port connector	DB-9	COM1
VGA connector	15-pin female VGA	VGA1

Table 3-2: Rear Panel Connectors

3.2 Internal Peripheral Connectors

Internal peripheral connectors are found on the motherboard and are only accessible when the motherboard is outside of the chassis. This section has complete descriptions of all the internal, peripheral connectors on the WAFER-PV-D5252/D4252/N4552.

3.2.1 ATX Power Connector

- CN Label:** J1
- CN Type:** 4-pin connector, p=4.2 mm
- CN Location:** See **Figure 3-2**
- CN Pinouts:** See **Table 3-3**

The ATX connector is connected to an external ATX power supply. Power is provided to the system, from the power supply through this connector.

WAFER-PV-D5252/D4252/N4552 SBC

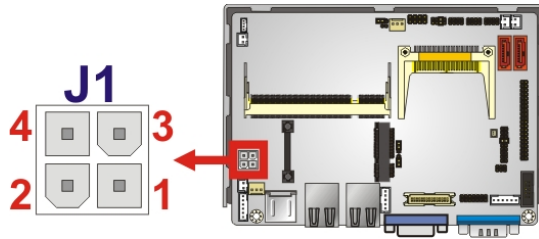

Figure 3-2: ATX Power Connector Location

Pin	Description	Pin	Description
1	Ground	2	Ground
3	+12 V	4	+12V

Table 3-3: ATX Power Connector Pinouts

3.2.2 Audio Connector

- CN Label:** AUDIO1
- CN Type:** 10-pin header, p=2.0 mm
- CN Location:** See Figure 3-3
- CN Pinouts:** See Table 3-4

This connector connects to speakers, a microphone and an audio input.

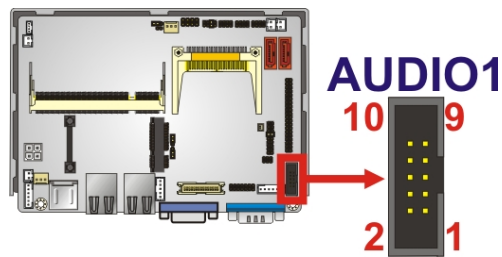

Figure 3-3: Audio Connector Location

Pin	Description	Pin	Description
1	LINE_OUTR	2	LINEIN_R
3	GND_AUDIO	4	GND_AUDIO
5	LINE_OUTL	6	LINEIN_L

Pin	Description	Pin	Description
7	GND_AUDIO	8	GND_AUDIO
9	MICIN	10	MICIN

Table 3-4: Audio Connector Pinouts

3.2.3 Battery Connector



CAUTION:

Risk of explosion if battery is replaced by an incorrect type. Only certified engineers should replace the on-board battery.

Dispose of used batteries according to instructions and local regulations.

- CN Label:** **BAT1**
- CN Type:** 2-pin wafer, p=1.25 mm
- CN Location:** See **Figure 3-4**
- CN Pinouts:** See **Table 3-5**

This is connected to the system battery. The battery provides power to the system clock to retain the time when power is turned off.

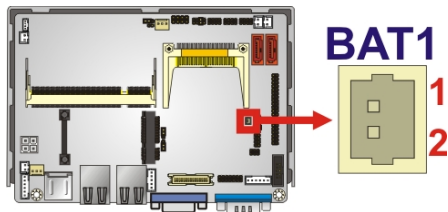

Figure 3-4: Battery Connector Location

Pin	Description
1	Battery+
2	Ground

Table 3-5: Battery Connector Pinouts

WAFER-PV-D5252/D4252/N4552 SBC

3.2.4 CompactFlash® Slot

- CN Label:** CF1
- CN Type:** CompactFlash® card slot
- CN Location:** See **Figure 3-5**
- CN Pinouts:** See **Table 3-6**



NOTE:

1. Both CompactFlash® Type I and Type II cards are supported.
2. To use SATA and CF, CF must be set to slave.

A CompactFlash® Type I or Type II card can be used in this slot.

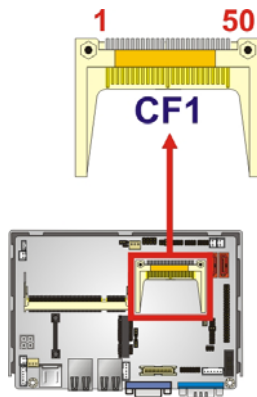

Figure 3-5: CompactFlash® Slot Location

Pin	Description	Pin	Description
1	GND	26	CD1#
2	D3	27	D11
3	D4	28	D12
4	D5	29	D13
5	D6	30	D14
6	D7	31	D15
7	CE#	32	CE2#

Pin	Description	Pin	Description
8	A10	33	VS1#
9	OE#	34	IOR#
10	A9	35	IOW#
11	A8	36	WE#
12	A7	37	IRQ
13	VCC	38	VCC
14	A6	39	CSEL#
15	A5	40	VS2#
16	A4	41	RESET#
17	A3	42	WAIT#
18	A2	43	INPACK#
19	A1	44	REG#
20	A0	45	BVD2
21	D0	46	BVD1
22	D1	47	D8
23	D2	48	D9
24	IOCS16#	49	D10
25	CD2#	50	GND2

Table 3-6: CompactFlash® Slot Pinouts

3.2.5 Digital I/O Connector

- CN Label:** DIO1
- CN Type:** 10-pin header, p=2.0 mm
- CN Location:** See **Figure 3-6**
- CN Pinouts:** See **Table 3-7**

The digital I/O connector provides programmable input and output for external devices. The digital I/O provides 4-bit output and 4-bit input.

WAFER-PV-D5252/D4252/N4552 SBC

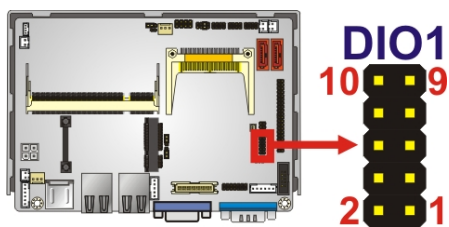

Figure 3-6: Digital I/O Connector Location

Pin	Description	Pin	Description
1	GND	2	VCC
3	Output 3	4	Output 2
5	Output 1	6	Output 0
7	Input 3	8	Input 2
9	Input 1	10	Input 0

Table 3-7: Digital I/O Connector Pinouts

3.2.6 Fan Connectors

- CN Label:** FAN1, FAN2
- CN Type:** 3-pin wafer, p=2.54 mm
- CN Location:** See **Figure 3-7**
- CN Pinouts:** See **Table 3-8**

The fan connector attaches to a cooling fan.

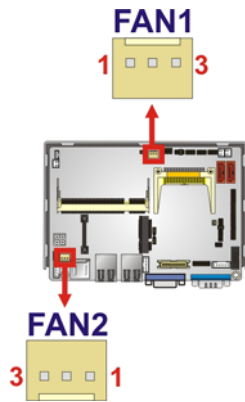

Figure 3-7: Fan Connector Locations

Pin	Description
1	FANIO1
2	+12V (PWM)
3	GND

Table 3-8: Fan Connector Pinouts

3.2.7 Keyboard/Mouse Connector

- CN Label:** KB/MS1
- CN Type:** 6-pin wafer, p=2.0 mm
- CN Location:** See **Figure 3-8**
- CN Pinouts:** See **Table 3-9**

The keyboard/mouse connector connects to a PS/2 Y-cable that can be connected to a PS/2 keyboard and mouse.

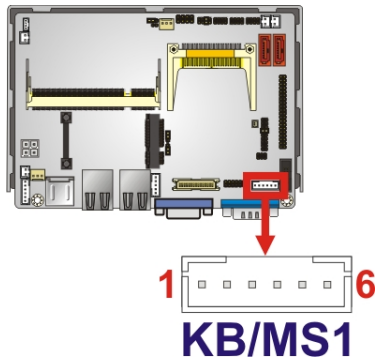

Figure 3-8: Keyboard/Mouse Connector Location

Pin	Description
1	VCC
2	Mouse Data
3	Mouse Clock
4	Keyboard Data
5	Keyboard Clock
6	GND

Table 3-9: Keyboard/Mouse Connector Pinouts

3.2.8 LED and +5 V Power Output Connector

- CN Label:** CN2
- CN Type:** 6-pin wafer, p=2.0 mm
- CN Location:** See **Figure 3-9**
- CN Pinouts:** See **Table 3-10**

The connector connects to the hard drive activity LED and power LED on the system front panel. +5 V power output is also provided via this connector.

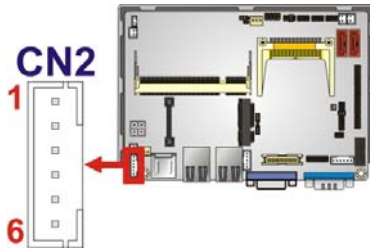

Figure 3-9: LED and +5 V Power Output Connector Location

	Pin	Description
+5 V Power Output	1	+5 V
	2	GND
Power LED	3	VCC
	4	GND
HDD LED	5	VCC
	6	-HDLED

Table 3-10: LED and +5 V Power Output Connector Pinouts

3.2.9 LVDS Connector

- CN Label:** LVDS1
- CN Type:** 30-pin crimp, p=1.25 mm
- CN Location:** See **Figure 3-10**
- CN Pinouts:** See **Table 3-11**

The LVDS connector is for an LCD panel connected to the board.

WAFER-PV-D5252/D4252/N4552 SBC

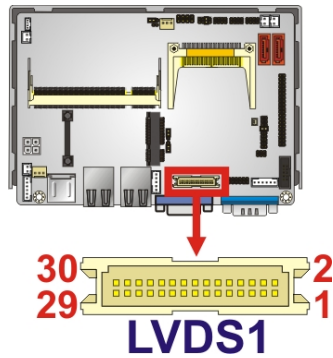

Figure 3-10: LVDS Connector Location

Pin	Description	Pin	Description
1	GROUND	2	GROUND
3	LVDS_A_TX0-P	4	LVDS_A_TX0-N
5	LVDS_A_TX1-P	6	LVDS_A_TX1-N
7	LVDS_A_TX2-P	8	LVDS_A_TX2-N
9	LVDS_A_TXCLK-P	10	LVDS_A_TXCLK-N
11	LVDS_A_TX3-P	12	LVDS_A_TX3-N
13	GROUND	14	GROUND
15	LVDS_B_TX0-P	16	LVDS_B_TX0-N
17	LVDS_B_TX1-P	18	LVDS_B_TX1-N
19	LVDS_B_TX2-P	20	LVDS_B_TX2-N
21	LVDS_B_TXCLK-P	22	LVDS_B_TXCLK-N
23	LVDS_B_TX3-P	24	LVDS_B_TX3-N
25	GROUND	26	GROUND
27	+LCD VCC	28	+LCD VCC
29	+LCD VCC	30	+LCD VCC

Table 3-11: LVDS Connector Pinouts

3.2.10 LVDS Backlight Connector

- CN Label:** INVERTER1
- CN Type:** 5-pin wafer, p=2.0 mm
- CN Location:** See Figure 3-11

CN Pinouts: See **Table 3-12**

The backlight inverter connector provides power to an LCD panel.

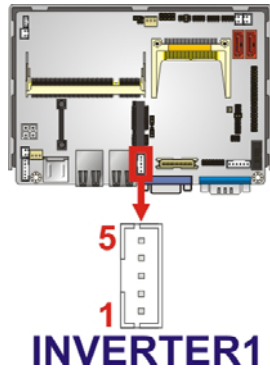

Figure 3-11: Backlight Inverter Connector

Pin	Description
1	LCD_BKLTCTL
2	GROUND
3	+12V
4	GROUND
5	BACKLIGHT ENABLE

Table 3-12: Backlight Inverter Connector

3.2.11 PCIe Mini Card Slot

CN Label: CN1
CN Type: PCIe Mini card slot
CN Location: See **Figure 3-12**
CN Pinouts: See **Table 3-13**

The PCIe mini card slot enables a PCIe mini card expansion module to be connected to the board. Cards supported include among others wireless LAN (WLAN) cards and IEI PCIe Mini disk on module (DOM) SSD cards.

WAFER-PV-D5252/D4252/N4552 SBC

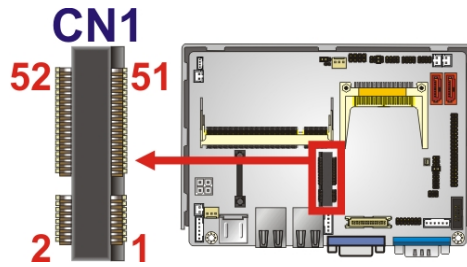

Figure 3-12: PCIe Mini Card Slot Location

Pin	Description	Pin	Description
1	PCIE_WAKE#	2	VCC3
3	N/C	4	GND
5	N/C	6	1.5V
7	CLKREQ#	8	LFRAME#
9	GND	10	LAD3
11	CLK-	12	LAD2
13	CLK+	14	LAD1
15	GND	16	LAD0
17	PCIRST#	18	GND
19	LPC	20	VCC3
21	GND	22	PCIRST#
23	PERN2	24	3VDual
25	PERP2	26	GND
27	GND	28	1.5V
29	GND	30	SMBCLK
31	PETN2	32	SMBDATA
33	PETP2	34	GND
35	GND	36	USBD-
37	GND	38	USBD+
39	SATARXP	40	GND
41	SATARXN	42	N/C
43	N/C	44	RF_LINK#
45	SATATXN	46	BLUELED#
47	SATATXP	48	1.5V

Pin	Description	Pin	Description
49	GND	50	GND
51	N/C	52	VCC3

Table 3-13: PCIe Mini Card Slot Pinouts

3.2.12 Power Button Connector

- CN Label:** PWR_BTN
- CN Type:** 2-pin wafer, p=2.0 mm
- CN Location:** See **Figure 3-13**
- CN Pinouts:** See **Table 3-14**

The power button connector is connected to a power switch on the system chassis.

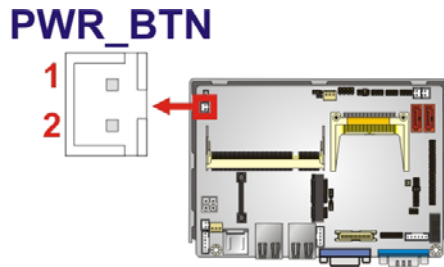

Figure 3-13: Power Button Connector Location

Pin	Description
1	Power Switch-
2	GND

Table 3-14: Power Button Connector Pinouts

3.2.13 Reset Button Connector

- CN Label:** RST_BTN
- CN Type:** 2-pin wafer, p=2.0 mm
- CN Location:** See **Figure 3-14**
- CN Pinouts:** See **Table 3-15**

WAFER-PV-D5252/D4252/N4552 SBC

The reset button connector is connected to a reset switch on the system chassis.

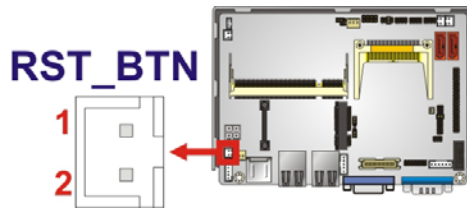

Figure 3-14: Reset Button Connector Location

Pin	Description
1	PM_RESET
2	GND

Table 3-15: Reset Button Connector Pinouts

3.2.14 RS-232/422/485 Serial Port Connector (COM6)

- CN Label:** COM6
- CN Type:** 14-pin header, p=2.0 mm
- CN Location:** See **Figure 3-15**
- CN Pinouts:** See **Table 3-16**

This connector provides RS-232, RS-422 or RS-485 communications.

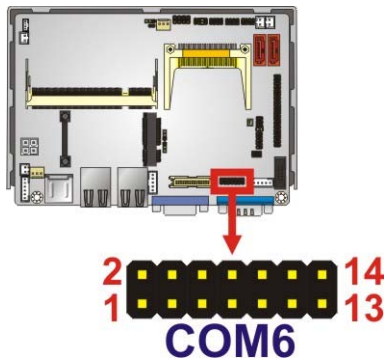

Figure 3-15: RS-232/422/485 Serial Port Connector Location

Pin	Description	Pin	Description
1	Data Carrier Direct (DCD)	2	Data Set Ready (DSR)
3	Receive Data (RXD)	4	Request To Send (RTS)
5	Transmit Data (TXD)	6	Clear To Send (CTS)
7	Data Terminal Ready (DTR)	8	Ring Indicator (RI)
9	Ground (GND)	10	N/C
11	TXD485+	12	TXD485#
13	RXD485+	14	RXD485#

Table 3-16: RS-232/422/485 Serial Port Connector Pinouts

3.2.15 RS-232 Serial Port Connector (COM2~COM5)

- CN Label:** COM2-5
- CN Type:** 40-pin header, p=2.0 mm
- CN Location:** See **Figure 3-16**
- CN Pinouts:** See **Table 3-17**

This connector provides RS-232 connections for four serial ports (COM2, COM3, COM4 and COM5).

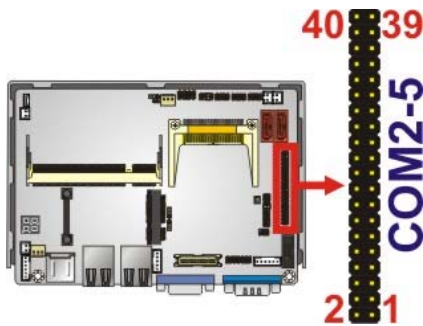

Figure 3-16: RS-232 Serial Port Connector Location

Pin	Description	Pin	Description
1	DATA CARRIER DETECT (DCD2)	2	DATA SET READY (DSR2)
3	RECEIVE DATA (RXD2)	4	REQUEST TO SEND (RTS2)
5	TRANSMIT DATA (TXD2)	6	CLEAR TO SEND (CTS2)
7	DATA TERMINAL READY (DTR2)	8	RING INDICATOR (RI2)

WAFER-PV-D5252/D4252/N4552 SBC

Pin	Description	Pin	Description
9	GND	10	GND
11	DATA CARRIER DETECT (DCD3)	12	DATA SET READY (DSR3)
13	RECEIVE DATA (RXD3)	14	REQUEST TO SEND (RTS3)
15	TRANSMIT DATA (TXD3)	16	CLEAR TO SEND (CTS3)
17	DATA TERMINAL READY (DTR3)	18	RING INDICATOR (RI3)
19	GND	20	GND
21	DATA CARRIER DETECT (DCD4)	22	DATA SET READY (DSR4)
23	RECEIVE DATA (RXD4)	24	REQUEST TO SEND (RTS4)
25	TRANSMIT DATA (TXD4)	26	CLEAR TO SEND (CTS4)
27	DATA TERMINAL READY (DTR4)	28	RING INDICATOR (RI4)
29	GND	30	GND
31	DATA CARRIER DETECT (DCD5)	32	DATA SET READY (DSR5)
33	RECEIVE DATA (RXD5)	34	REQUEST TO SEND (RTS5)
35	TRANSMIT DATA (TXD5)	36	CLEAR TO SEND (CTS5)
37	DATA TERMINAL READY (DTR5)	38	RING INDICATOR (RI5)
39	GND	40	GND

Table 3-17: Serial Port Connector Pinouts

3.2.16 SATA Drive Connectors

- CN Label:** SATA1, SATA2
- CN Type:** 7-pin SATA drive connectors
- CN Location:** See **Figure 3-17**
- CN Pinouts:** See **Table 3-18**

The SATA connectors connect to SATA hard drives or optical drives.

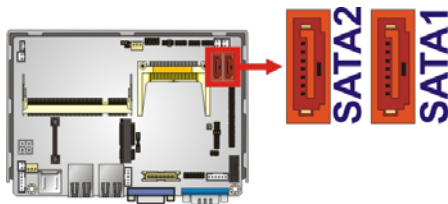

Figure 3-17: SATA Drive Connector Location

Pin	Description
1	GND
2	TX+
3	TX-
4	GND
5	RX-
6	RX+
7	GND

Table 3-18: SATA Drive Connector Pinouts

3.2.17 SATA Power Connectors

CN Label: SATA_PWR1, SATA_PWR2

CN Type: 2-pin wafer, p=2.0 mm

CN Location: See **Figure 3-18**

CN Pinouts: See **Table 3-19**

Use the SATA Power Connector to connect to SATA device power connections.

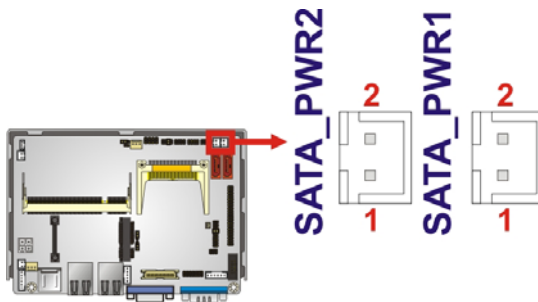

Figure 3-18: SATA Power Connector Locations

Pin	Description
1	VCC5
2	GND

Table 3-19: SATA Power Connector Pinouts

WAFER-PV-D5252/D4252/N4552 SBC

3.2.18 SMBus Connector

- CN Label:** CN3
- CN Type:** 4-pin wafer, p=1.25 mm
- CN Location:** See **Figure 3-19**
- CN Pinouts:** See **Table 3-20**

The SMBus (System Management Bus) connector provides low-speed system management communications.

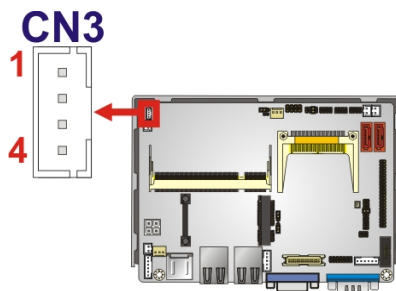

Figure 3-19: SMBus Connector Location

Pin	Description
1	GND
2	SMBDATA
3	SMBCLK
4	+5V

Table 3-20: SMBus Connector Pinouts

3.2.19 SO-DIMM Connector

- CN Label:** DIMM1
- CN Type:** 204-pin DDR3 SO-DIMM connector
- CN Location:** See **Figure 3-20**

The SO-DIMM connector is for installing memory on the system.

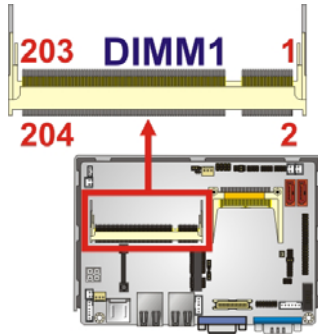

Figure 3-20: SO-DIMM Connector Location

3.2.20 SPI Flash Connector

- CN Label:** JSPI1
- CN Type:** 8-pin header, p=2.54 mm
- CN Location:** See Figure 3-21
- CN Pinouts:** See Table 3-21

The 8-pin SPI Flash connector is used to flash the BIOS.

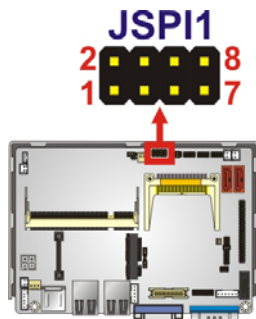

Figure 3-21: SPI Flash Connector Location

Pin	Description	Pin	Description
1	VCC	2	GND
3	CS#	4	CLOCK
5	SO	6	SI
7	NC	8	NC

Table 3-21: SPI Flash Connector Pinouts

WAFER-PV-D5252/D4252/N4552 SBC

3.2.21 USB Connectors

- CN Label:** USB2, USB3, USB4
- CN Type:** 8-pin header, p=2.0 mm
- CN Location:** See **Figure 3-22**
- CN Pinouts:** See **Table 3-22**

The USB header can connect to two USB devices.

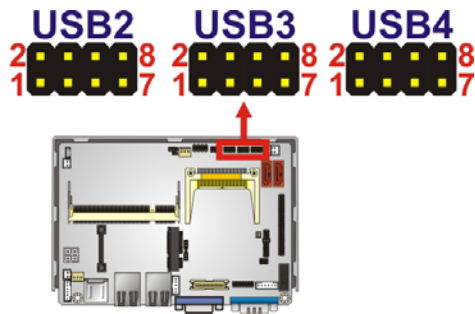

Figure 3-22: USB Connector Location

Pin	Description	Pin	Description
1	VCC	2	GND
3	DATA-	4	DATA+
5	DATA+	6	DATA-
7	GND	8	VCC

Table 3-22: USB Port Connector Pinouts

3.3 External Interface Connectors

Figure 3-23 shows the WAFER-PV-D5252/D4252/N4552 motherboard external interface connectors. The WAFER-PV-D5252/D4252/N4552 on-board external interface connectors are shown in Figure 3-23.

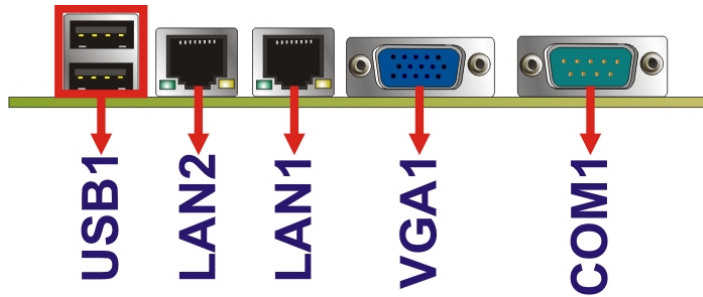

Figure 3-23: External Interface Connectors

3.3.1 Ethernet Connectors

CN Label: LAN1, LAN2

CN Type: RJ-45

CN Location: See **Figure 3-23**

CN Pinouts: See **Table 3-23**

A 10/100/1000 Mb/s connection can be made to a Local Area Network.

Pin	Description	Pin	Description
1	MDIA3-	5	MDIA1+
2	MDIA3+	6	MDIA2+-
3.	MDIA2-	7	MDIA0-
4.	MDIA1-	8	MDIA0+

Table 3-23: Ethernet Connector Pinouts

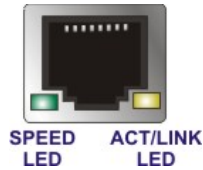

Figure 3-24: Ethernet Connector

The RJ-45 Ethernet connector has two status LEDs, one green and one yellow. The green LED indicates activity on the port and the yellow LED indicates the port is linked. See **Table 3-24**.

SPEED LED		ACT/LINK LED	
STATUS	DESCRIPTION	STATUS	DESCRIPTION
OFF	10Mbps connection	OFF	No link
GREEN	100Mbps connection	YELLOW	Linked
ORANGE	1Gbps connection	BLINKING	Data Activity

Table 3-24: RJ-45 Ethernet Connector LEDs

3.3.2 Serial Port Connector

- CN Label:** COM1
- CN Type:** DB-9 Male connector
- CN Location:** See **Figure 3-23**
- CN Pinouts:** See **Table 3-25** and **Figure 3-25**

The RS-232 serial connector provides serial connection in the RS-232 mode.

Pin	Description	Pin	Description
1	DCD	6	DSR
2	RXD	7	RTS
3	TXD	8	CTS
4	DTR	9	RI
5	GND		

Table 3-25: Serial Port Pinouts

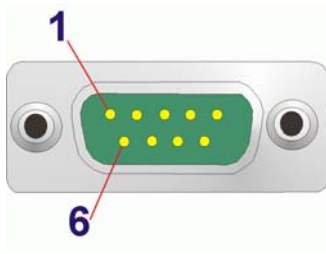

Figure 3-25: Serial Port Pinout Locations

3.3.3 USB Ports

- CN Label:** USB1
- CN Type:** USB Combo ports
- CN Location:** See **Figure 3-23**
- CN Pinouts:** See **Table 3-26**

The USB ports attach to standard USB devices.

Pin	Description
1	VCC
2	Data1-
3	Data1+
4	Ground
5	VCC
6	Data2-
7	Data2+
8	Ground

Table 3-26: USB Connector Pinouts

3.3.4 VGA Connector

- CN Label:** VGA1
- CN Type:** D-sub 15-pin female connector
- CN Location:** See **Figure 3-23**
- CN Pinouts:** See **Figure 3-26** an **Table 3-27**

WAFER-PV-D5252/D4252/N4552 SBC

The standard 15-pin female VGA connector connects to a CRT or LCD monitor.

Pin	Description	Pin	Description	Pin	Description
1	RED	6	GROUND	11	NC
2	GREEN	7	GROUND	12	SDA
3	BLUE	8	GROUND	13	HSYNC
4	+5V	9	NC	14	VSYNC
5	GROUND	10	GROUND	15	SCL

Table 3-27: VGA Connector Pinouts

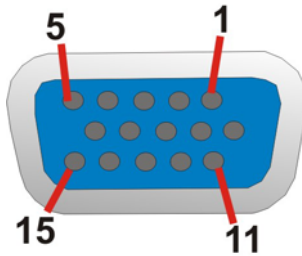

Figure 3-26: VGA Connector

Chapter

4

Installation

4.1 Anti-static Precautions



WARNING:

Failure to take ESD precautions during installation may result in permanent damage to the product and severe injury to the user.

Electrostatic discharge (ESD) can cause serious damage to electronic components, including the WAFER-PV-D5252/D4252/N4552. Dry climates are especially susceptible to ESD. It is therefore critical to strictly adhere to the following anti-static precautions whenever the WAFER-PV-D5252/D4252/N4552, or any other electrical component, is handled.

- **Wear an anti-static wristband:** - Wearing a simple anti-static wristband can help to prevent ESD from damaging the board.
- **Self-grounding:** - Before handling the board touch any grounded conducting material. During the time the board is handled, frequently touch any conducting materials that are connected to the ground.
- **Use an anti-static pad:** When configuring the WAFER-PV-D5252/D4252/N4552, place it on an anti-static pad. This reduces the possibility of ESD damaging the WAFER-PV-D5252/D4252/N4552.
- **Only handle the edges of the PCB:-:** When handling the PCB, hold it by the edges.

4.2 Installation Considerations



NOTE:

The following installation notices and installation considerations should be read and understood before the WAFER-PV-D5252/D4252/N4552 is installed. All installation notices pertaining to the installation of WAFER-PV-D5252/D4252/N4552 should be strictly adhered to. Failing to adhere to these precautions may lead to severe damage of the WAFER-PV-D5252/D4252/N4552 and injury to the person installing the motherboard.



WARNING:

The installation instructions described in this manual should be carefully followed in order to prevent damage to the WAFER-PV-D5252/D4252/N4552, WAFER-PV-D5252/D4252/N4552 components and injury to the user.

Before and during the installation please **DO** the following:

- **Read the user manual:**
 - The user manual provides a complete description of the installation instructions and configuration options.
- **Wear an electrostatic discharge cuff (ESD):**
 - Electronic components are easily damaged by ESD. Wearing an ESD cuff removes ESD from the body and helps prevent ESD damage.
- **Place on an antistatic pad:**
 - When installing or configuring the motherboard, place it on an antistatic pad. This helps to prevent potential ESD damage.
- **Turn all power off:**
 - Make sure the product is disconnected from all power supplies and that no electricity is being fed into the system.

WAFER-PV-D5252/D4252/N4552 SBC

Before and during the installation of the WAFER-PV-D5252/D4252/N4552 **DO NOT**:

- **DO NOT** remove any of the stickers on the PCB board. These stickers are required for warranty validation.
- **DO NOT** use the product before verifying all the cables and power connectors are properly connected.
- **DO NOT** allow screws to come in contact with the PCB circuit, connector pins, or its components.

4.3 SO-DIMM Installation

To install an SO-DIMM, please follow the steps below and refer to Figure 4-1.

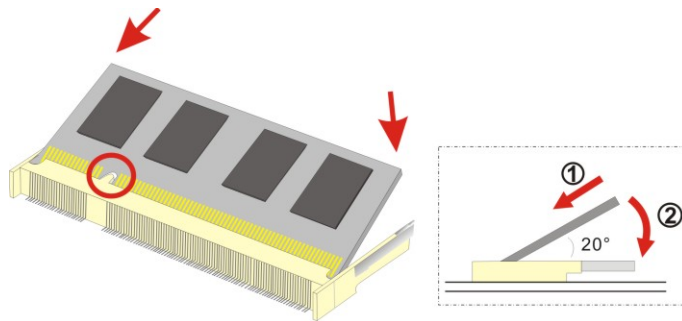

Figure 4-1: SO-DIMM Installation

Step 1: Locate the SO-DIMM socket. Place the board on an anti-static mat.

Step 2: Align the SO-DIMM with the socket. Align the notch on the memory with the notch on the memory socket.

Step 3: Insert the SO-DIMM. Push the memory in at a 20° angle. (See Figure 4-1)

Step 4: Seat the SO-DIMM. Gently push downwards and the arms clip into place. (See Figure 4-1)

4.4 CompactFlash® Installation

**NOTE:**

Both CompactFlash® Type I and Type II cards are supported.

To install the CompactFlash® card, please follow the steps below.

- Step 1:** **Locate the CF card socket.** Locate the CompactFlash® slot.
- Step 2:** **Align the CF card.** Align the CompactFlash® card. The label side should be facing away from the board. The grooves on the CompactFlash® slot ensure that the card cannot be inserted the wrong way.
- Step 3:** **Insert the CF card.** Push until the CompactFlash® card is firmly seated in the slot. See Figure 4-2.

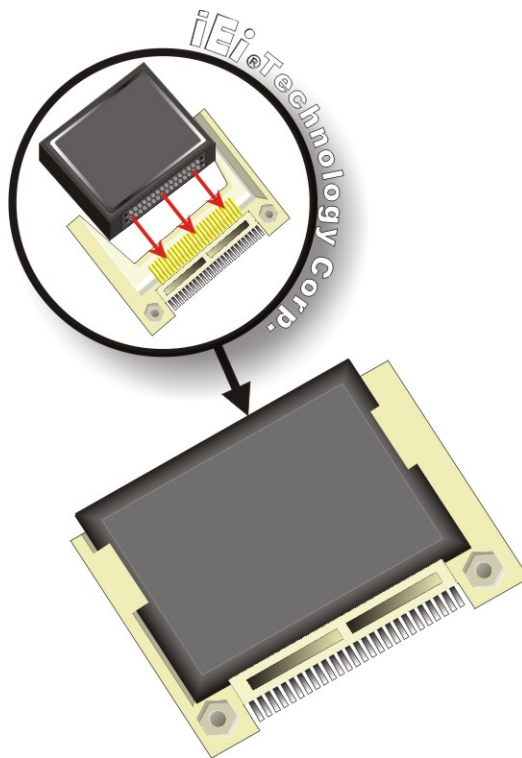

Figure 4-2: CompactFlash® Card Installation

4.5 Jumper Settings



NOTE:

A jumper is a metal bridge that is used to close an electrical circuit. It consists of two metal pins and a small metal clip (often protected by a plastic cover) that slides over the pins to connect them. To CLOSE/SHORT a jumper means connecting the pins of the jumper with the plastic clip and to OPEN a jumper means removing the plastic clip from a jumper.

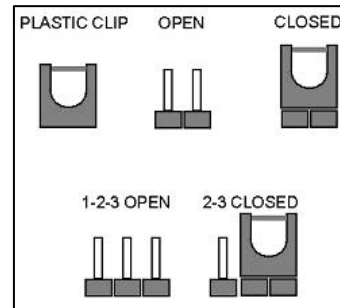

Before the WAFER-PV-D5252/D4252/N4552 is installed in the system, the jumpers must be set in accordance with the desired configuration. The jumpers on the WAFER-PV-D5252/D4252/N4552 are listed in Table 4-1.

Description	Label	Type
AT/ATX mode selection	J_AUTOPWR1	3-pin header
Clear CMOS	J_CMOS1	3-pin header
LVDS voltage selection	J_VLVDS1	3-pin header
LVDS resolution selection	J_LCD_TYPE1	8-pin header
CompactFlash® master/slave selection	JCF1	2-pin header
COM6 RS-232/422/485 selection	JP1	8-pin header
COM1 pin-9 voltage selection	JP2	6-pin header

Table 4-1: Jumpers

4.5.1 AT/ATX Mode Selection

Jumper Label: J_AUTOPWR1
Jumper Type: 3-pin header, p=2.0 mm

Jumper Settings: See Table 4-2

Jumper Location: See Figure 4-3

Set both of the jumpers select AT or ATX power mode for the WAFER-PV-D5252/D4252/N4552. AT power mode limits the system to on/off. ATX allows the system to use various power saving states and enter a standby state, so the system can be turned on remotely over a network. The settings on both jumpers should be the same.

Pin	Description
Short 1-2	ATX mode (Default)
Short 2-3	AT mode

Table 4-2: AT/ATX Mode Selection

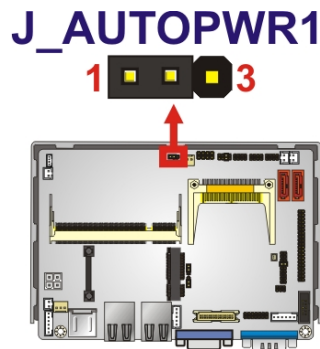

Figure 4-3: AT/ATX Mode Selection Jumper Location

4.5.2 Clear CMOS Jumper

Jumper Label: J_CMOS1

Jumper Type: 3-pin header, p=2.0 mm

Jumper Settings: See Table 4-3

Jumper Location: See Figure 4-4

If the WAFER-PV-D5252/D4252/N4552 fails to boot due to improper BIOS settings, the clear CMOS jumper clears the CMOS data and resets the system BIOS information. To do this, use the jumper cap to close pins 2 and 3 for a few seconds then reinstall the jumper clip back to pins 1 and 2.

WAFER-PV-D5252/D4252/N4552 SBC

If the “CMOS Settings Wrong” message is displayed during the boot up process, the fault may be corrected by pressing the F1 to enter the CMOS Setup menu. Do one of the following:

- Enter the correct CMOS setting
- Load Optimal Defaults
- Load Failsafe Defaults.

After having done one of the above, save the changes and exit the CMOS Setup menu.

The clear CMOS jumper settings are shown in Table 4-3.

Pin	Description
1-2	Keep CMOS Setup (Default)
2-3	Clear CMOS Setup

Table 4-3: Clear CMOS Jumper Settings

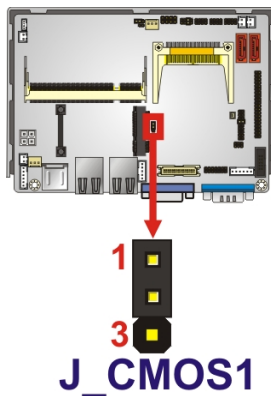

Figure 4-4: Clear CMOS Jumper Location

4.5.3 LVDS Voltage Selection

Jumper Label:	J_VLVDS1
Jumper Type:	3-pin header, p=2.0 mm
Jumper Settings:	See Table 4-4
Jumper Location:	See Figure 4-5

The jumper selects the voltage of the LVDS connector.

Pin	Description
Short 1-2	+5 V
Short 2-3	+3.3 V (Default)

Table 4-4: LVDS Voltage Selection

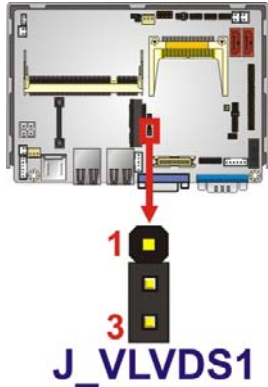

Figure 4-5: LVDS Voltage Selection Jumper Location

4.5.4 LVDS Resolution Selection

- Jumper Label:** J_LCD_TYPE1
- Jumper Type:** 8-pin header, p=2.0 mm
- Jumper Settings:** See Table 4-5
- Jumper Location:** See Figure 4-6

The jumper selects the resolution of the LCD panel connected to the LVDS1 connector.

Pin	Description
Open	640 x 480 (18-bit)
Short 1-2	800 x 480 (18-bit)
Short 3-4	800 x 600 (18-bit) (Default)
Short 1-2, 3-4	1024 x 768 (18-bit)
Short 5-6	1280 x 1024 (18-bit)
Short 1-2, 5-6	1366 x 768 (18-bit)
Short 3-4, 5-6	1280 x 800 (18-bit)
Short 1-2, 3-4, 5-6	1280 x 600 (18-bit)

Table 4-5: LVDS Resolution Selection

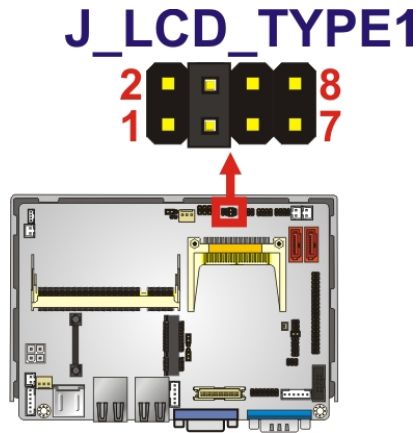

Figure 4-6: LVDS Resolution Selection Jumper Location

4.5.5 CompactFlash® Master/Slave Selection

- Jumper Label:** JCF1
- Jumper Type:** 2-pin header, p=2.0 mm
- Jumper Settings:** See Table 4-6
- Jumper Location:** See Figure 4-7



NOTE:

To use SATA and CF, CF must be set as slave

The jumper sets the CompactFlash® slot as the IDE primary master or primary slave.

Pin	Description
Closed	Master
Open	Slave (Default)

Table 4-6: CompactFlash® Master/Slave Selection

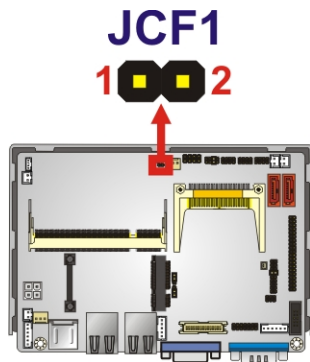

Figure 4-7: CompactFlash® Master/Slave Selection Jumper Location

4.5.6 COM6 RS-232/422/485 Selection

- Jumper Label:** JP1
- Jumper Type:** 8-pin header, p=2.0 mm
- Jumper Settings:** See Table 4-7
- Jumper Location:** See Figure 4-8

The jumper selects the communication method of COM6 serial port.

Pin	Description
Short 1-2	RS-232 (Default)
Short 3-4	RS-422
Short 5-6	RS-485
Short 5-6, 7-8	RS-485 with RTS control

Table 4-7: COM6 RS-232/422/485 Selection

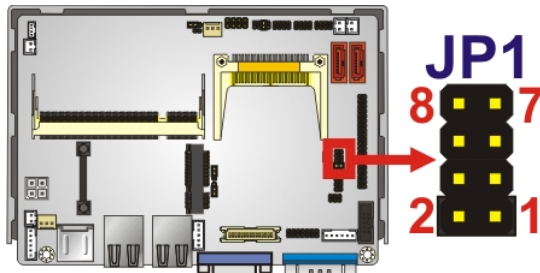

Figure 4-8: COM6 RS-232/422/485 Selection Jumper Location

WAFER-PV-D5252/D4252/N4552 SBC

4.5.7 COM 1 Pin 9 Setting Jumper

- Jumper Label:** JP2
- Jumper Type:** 6-pin header, p=2.0 mm
- Jumper Settings:** See Table 4-8
- Jumper Location:** See Figure 4-9

The COM 1 Pin 9 Setting jumper configures pin 9 on COM 1 as either a +5 V, +12 V power source or as a ring-in (RI) line. The COM 1 Pin 9 Setting jumper selection options are shown in Table 4-8.

Setting	Description
Short 1-3	COM 1 RI Pin use +5 V (Default)
Short 3-5	COM 1 RI Pin use +12 V
Short 3-4	COM 1 RI Pin use RI

Table 4-8: COM 1 Pin 9 Setting Jumper Settings

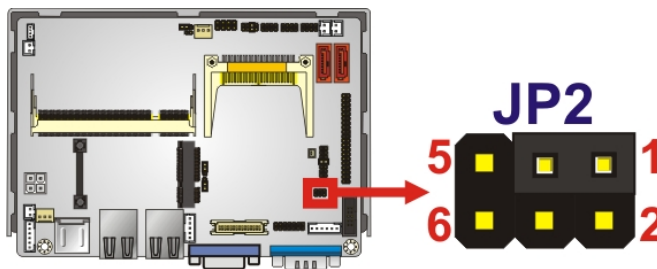

Figure 4-9: COM 1 Pin 9 Setting Jumper Location

4.6 Chassis Installation

4.6.1 Heat Sink Enclosure

**WARNING:**

Never run the WAFER-PV-D5252/D4252/N4552 without the heat sink secured to the board. The heat sink ensures the system remains cool and does not need addition heat sinks to cool the system.

**WARNING:**

When running the WAFER-PV-D5252/D4252/N4552, do not put the WAFER-PV-D5252/D4252/N4552 directly on a surface that can not dissipate system heat, especially the wooden or plastic surface. It is highly recommended to run the WAFER-PV-D5252/D4252/N4552

- on a heat dissipation surface or
 - using copper pillars to hold the board up from the chassis
-

When the WAFER-PV-D5252/D4252/N4552 is shipped, it is secured to a heat sink with four retention screws. If the WAFER-PV-D5252/D4252/N4552 must be removed from the heat sink, the four retention screws must be removed.



Figure 4-10: Heat Sink Retention Screws

WAFER-PV-D5252/D4252/N4552 SBC

4.6.2 Motherboard Installation

Each side of the heat sink enclosure has several screw holes allowing the WAFER-PV-D5252/D4252/N4552 to be mounted into a chassis (please refer to Error! Reference source not found. for the detailed dimensions). The user can design or select a chassis that has screw holes matching up with the holes on the heat sink enclosure for installing the WAFER-PV-D5252/D4252/N4552. The following diagram shows an example of motherboard installation.

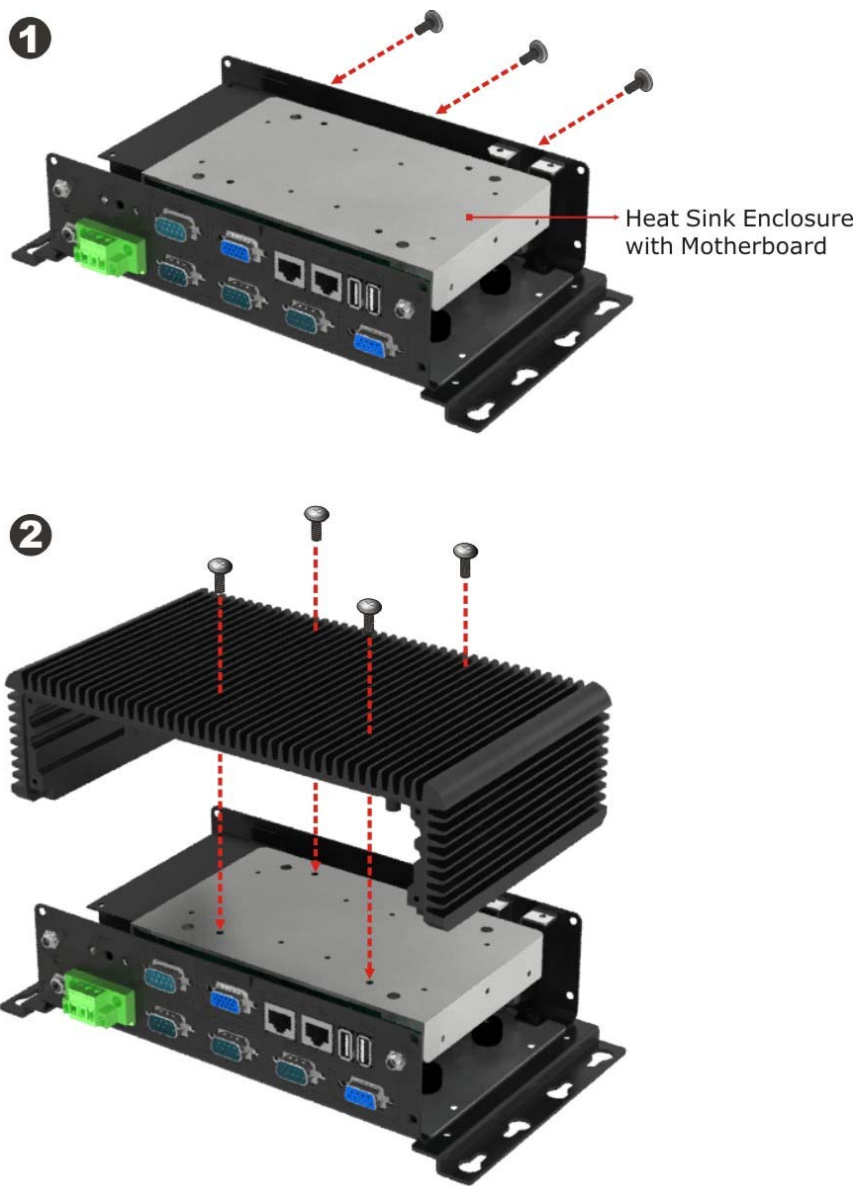

Figure 4-11: Motherboard Installation Example

4.7 Internal Peripheral Device Connections

This section outlines the installation of peripheral devices to the onboard connectors.

4.7.1 AT Power Connection

Follow the instructions below to connect the WAFER-PV-D5252/D4252/N4552 to an AT power supply.



WARNING:

Disconnect the power supply power cord from its AC power source to prevent a sudden power surge to the WAFER-PV-D5252/D4252/N4552.

Step 1: Locate the power cable. The power cable is shown in the packing list in Chapter 3.

Step 2: Connect the Power Cable to the Motherboard. Connect the 4-pin (2x2) Molex type power cable connector to the AT power connector on the motherboard. See Figure 4-12.

WAFER-PV-D5252/D4252/N4552 SBC

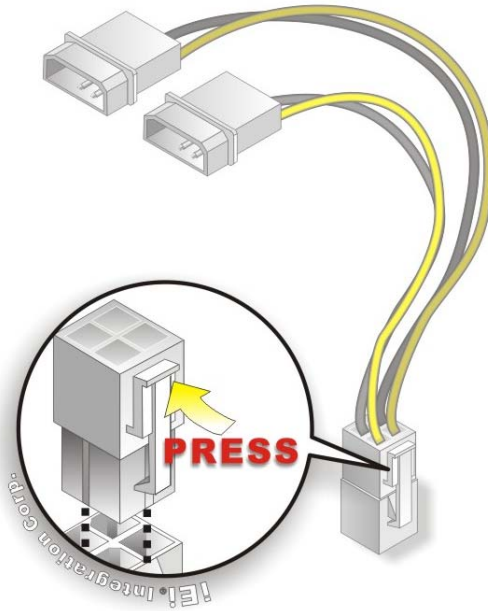

Figure 4-12: Power Cable to Motherboard Connection

Step 3: Connect Power Cable to Power Supply. Connect one of the 4-pin (1x4) Molex type power cable connectors to an AT power supply. See Figure 4-13.

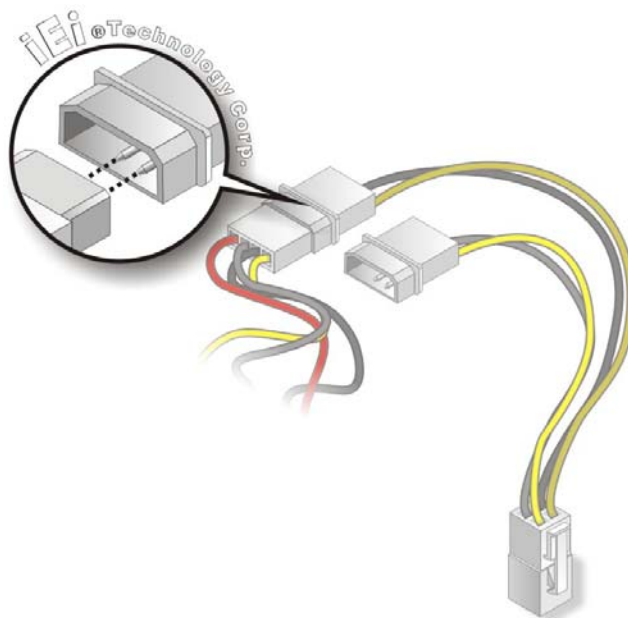

Figure 4-13: Connect Power Cable to Power Supply

4.7.2 Audio Kit Installation

The Audio Kit that came with the WAFER-PV-D5252/D4252/N4552 connects to the audio connector on the WAFER-PV-D5252/D4252/N4552. The audio kit consists of three audio jacks. Mic-in connects to a microphone. Line-in provides a stereo line-level input to connect to the output of an audio device. Line-out, a stereo line-level output, connects to two amplified speakers. To install the audio kit, please refer to the steps below:

Step 1: Locate the audio connector. The location of the 10-pin audio connector is shown in **Chapter 3**.

Step 2: Align pin 1. Align pin 1 on the on-board connector with pin 1 on the audio kit connector. Pin 1 on the audio kit connector is indicated with a white dot. See Figure 4-14.

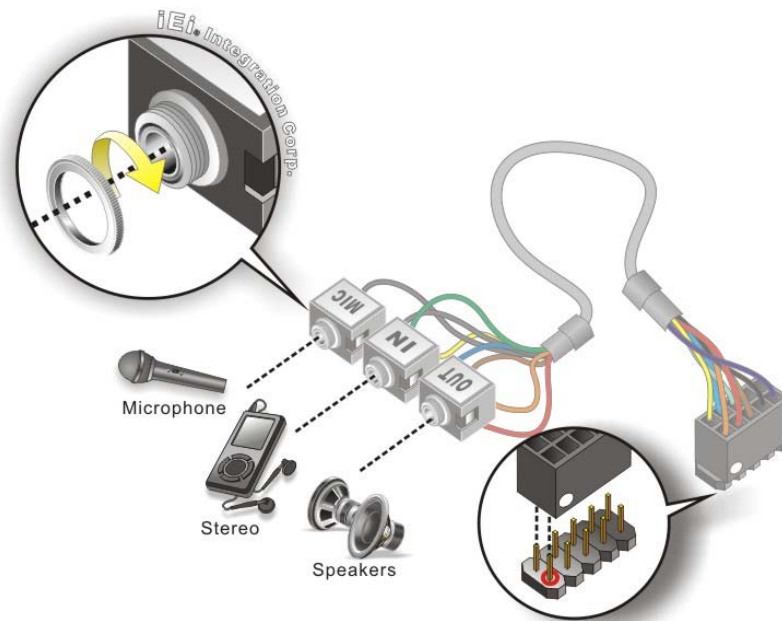

Figure 4-14: Audio Kit Cable Connection

Step 3: Connect the audio devices. Connect speakers to the line-out audio jack. Connect the output of an audio device to the line-in audio jack. Connect a microphone to the mic-in audio jack.

WAFER-PV-D5252/D4252/N4552 SBC

4.7.3 Keyboard/Mouse Connector

The WAFER-PV-D5252/D4252/N4552 is shipped with a keyboard/mouse Y-cable connector. The keyboard/mouse Y-cable connector connects to a keyboard/mouse connector on the WAFER-PV-D5252/D4252/N4552 and branches into two cables that are each connected to a PS/2 connector, one for a mouse and one for a keyboard. To connect the keyboard/mouse Y-cable connector please follow the steps below.

- Step 1: Locate the connector.** The location of the keyboard/mouse Y-cable connector is shown in **Chapter 3**.
- Step 2: Align the connectors.** Correctly align pin 1 on the cable connector with pin 1 on the WAFER-PV-D5252/D4252/N4552 keyboard/mouse connector. See Figure 4-15.
- Step 3: Insert the cable connectors** Once the cable connector is properly aligned with the keyboard/mouse connector on the WAFER-PV-D5252/D4252/N4552, connect the cable connector to the on-board connectors. See Figure 4-15.

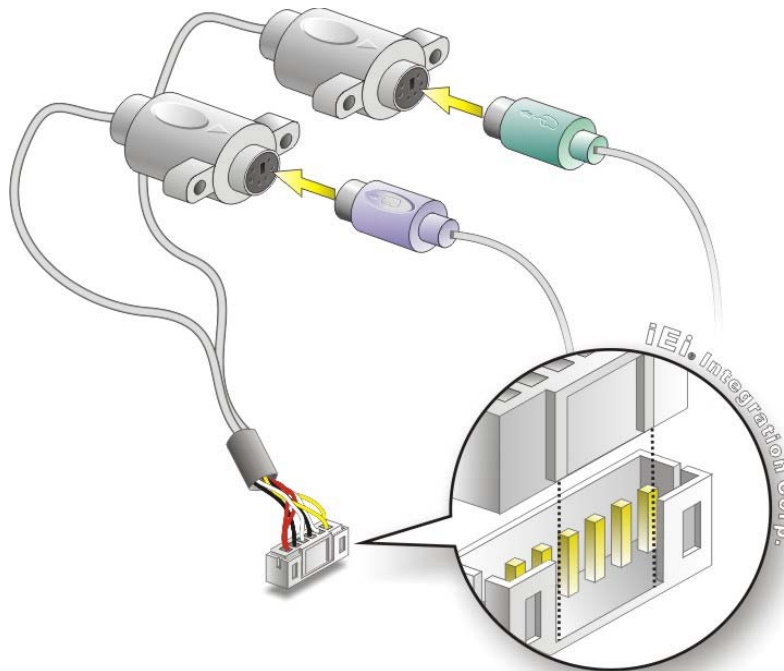

Figure 4-15: Keyboard/mouse Y-cable Connection

Step 4: **Attach PS/2 connectors to the chassis.** The keyboard/mouse Y-cable connector is connected to two PS/2 connectors. To secure the PS/2 connectors to the chassis please refer to the installation instructions that came with the chassis.

Step 5: **Connect the keyboard and mouse.** Once the PS/2 connectors are connected to the chassis, a keyboard and mouse can each be connected to one of the PS/2 connectors. The keyboard PS/2 connector and mouse PS/2 connector are both marked. Please make sure the keyboard and mouse are connected to the correct PS/2 connector.

4.7.4 Four Serial Port Connector

The 40-pin serial port connector connects the board connector to four DB-9 connectors. To install, please follow the steps below.

Step 1: **Locate the COM connector.** The locations of the COM port connectors are shown in Chapter 4.

Step 2: **Insert the cable connector.** Align the cable connector with the onboard connector. Make sure pin 1 on the board and connector line up..

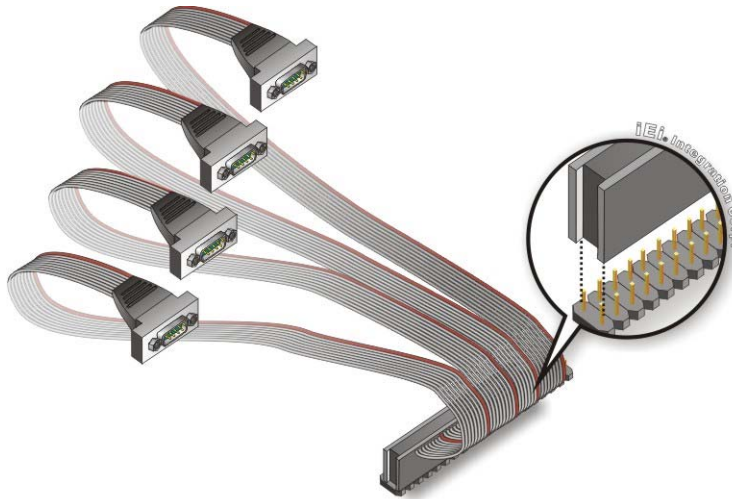

Figure 4-16: Four Serial Port Connector

WAFER-PV-D5252/D4252/N4552 SBC

Step 3: Secure the serial ports to the chassis. Tighten the screws on the DB-9 connectors to secure them to the chassis.

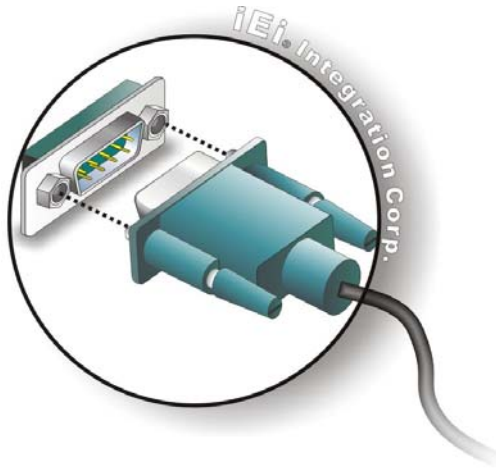

Figure 4-17: Serial Device Connector

4.8 Software Installation

All the drivers for the WAFER-PV-D5252/D4252/N4552 are on the CD that came with the system. To install the drivers, please follow the steps below.

Step 1: Insert the CD into a CD drive connected to the system.



NOTE:

If the installation program doesn't start automatically:
Click "Start->My Computer->CD Drive->autorun.exe"

Step 2: The driver main menu appears (Figure 4-18).



Figure 4-18: Introduction Screen

Step 3: Click WAFER-PV-D5252/D4252/N4552.

Step 4: A new screen with a list of available drivers appears (Figure 4-19).



Figure 4-19: Available Drivers

Step 5: Install all of the necessary drivers in this menu.

Chapter

5

BIOS

5.1 Introduction

The BIOS is programmed onto the BIOS chip. The BIOS setup program allows changes to certain system settings. This chapter outlines the options that can be changed.



NOTE:

Some of the BIOS options may vary throughout the life cycle of the product and are subject to change without prior notice.

5.1.1 Starting Setup

The UEFI BIOS is activated when the computer is turned on. The setup program can be activated in one of two ways.

1. Press the **DELETE** or **F2** key as soon as the system is turned on or
2. Press the **DELETE** or **F2** key when the “**Press Del to enter SETUP**” message appears on the screen.

If the message disappears before the **DELETE** or **F2** key is pressed, restart the computer and try again.

5.1.2 Using Setup

Use the arrow keys to highlight items, press **ENTER** to select, use the PageUp and PageDown keys to change entries, press **F1** for help and press **ESC** to quit. Navigation keys are shown in.

Key	Function
Up arrow	Move to the item above
Down arrow	Move to the item below
Left arrow	Move to the item on the left hand side
Right arrow	Move to the item on the right hand side
+	Increase the numeric value or make changes

Key	Function
-	Decrease the numeric value or make changes
Page up	Move to the next page
Page down	Move to the previous page
Esc	Main Menu – Quit and do not save changes into CMOS Status Page Setup Menu and Option Page Setup Menu -- Exit current page and return to Main Menu
F1 key	General help, only for Status Page Setup Menu and Option Page Setup Menu
F2 key	Load previous values
F3 key	Load optimized defaults
F4 key	Save changes and Exit BIOS

Table 5-1: BIOS Navigation Keys

5.1.3 Getting Help

When **F1** is pressed a small help window describing the appropriate keys to use and the possible selections for the highlighted item appears. To exit the Help Window press **Esc** or the **F1** key again.

5.1.4 Unable to Reboot After Configuration Changes

If the computer cannot boot after changes to the system configuration is made, CMOS defaults. Use the jumper described in **Chapter 4**.

5.1.5 BIOS Menu Bar

The **menu bar** on top of the BIOS screen has the following main items:

- Main – Changes the basic system configuration.
- Advanced – Changes the advanced system settings.
- Chipset – Changes the chipset settings.
- Boot – Changes the system boot configuration.
- Security – Sets User and Supervisor Passwords.

- Save & Exit – Selects exit options and loads default settings

The following sections completely describe the configuration options found in the menu items at the top of the BIOS screen and listed above.

5.2 Main

The **Main** BIOS menu (**BIOS Menu 1**) appears when the **BIOS Setup** program is entered. The **Main** menu gives an overview of the basic system information.

```

Aptio Setup Utility - Copyright (C) 2010 American Megatrends, Inc.
Main  Advanced  Chipset  Boot  Security  Save & Exit
-----
BIOS Information
BIOS Vendor          American Megatrends
Core Version         4.6.4.0 0.20
Compliancy           UEFI 2.0
Project Version      E338AR25.ROM
Build Date           03/17/2014 13:18:02

System Date          [Fri 01/01/2010]
System Time          [00:01:27]

Access Level         Administrator

Set the Time. Use Tab to
switch between Time
elements.

-----
<=>: Select Screen
↑ ↓: Select Item
Enter>Select
F1  General Help
F2  Previous Values
F3  Optimized Defaults
F4  Save
ESC Exit

Version 2.02.1205. Copyright (C) 2010 American Megatrends, Inc.
    
```

BIOS Menu 1: Main

→ BIOS Information

The **BIOS Information** lists a brief summary of the BIOS. The fields in **BIOS Information** cannot be changed. The items shown in the system overview include:

- **BIOS Vendor:** Installed BIOS vendor
- **Core Version:** Current BIOS version
- **Project Version:** the board version
- **Build Date:** Date the current BIOS version was made

The System Overview field also has two user configurable fields:

WAFER-PV-D5252/D4252/N4552 SBC

→ System Date [xx/xx/xx]

Use the **System Date** option to set the system date. Manually enter the day, month and year.

→ System Time [xx:xx:xx]

Use the **System Time** option to set the system time. Manually enter the hours, minutes and seconds.

5.3 Advanced

Use the **Advanced** menu (**BIOS Menu 2**) to configure the CPU and peripheral devices through the following sub-menus:



WARNING!

Setting the wrong values in the sections below may cause the system to malfunction. Make sure that the settings made are compatible with the hardware.

```

Aptio Setup Utility - Copyright (C) 2010 American Megatrends, Inc.
Main  Advanced  Chipset  Boot  Security  Save & Exit
-----
> ACPI Settings
> RTC Wake Settings
> CPU Configuration
> IDE Configuration
> USB Configuration
> Super IO Configuration
> H/M Monitor
> Serial Port Console Redirection
> iEi Feature

System ACPI Parameters
-----
<=>: Select Screen
↑ ↓: Select Item
Enter>Select
F1  General Help
F2  Previous Values
F3  Optimized
Defaults
F4  Save
ESC Exit

Version 2.02.1205. Copyright (C) 2010 American Megatrends, Inc.
    
```

BIOS Menu 2: Advanced

5.3.1 ACPI Configuration

The **ACPI Configuration** menu (**BIOS Menu 3**) configures the Advanced Configuration and Power Interface (ACPI) options.

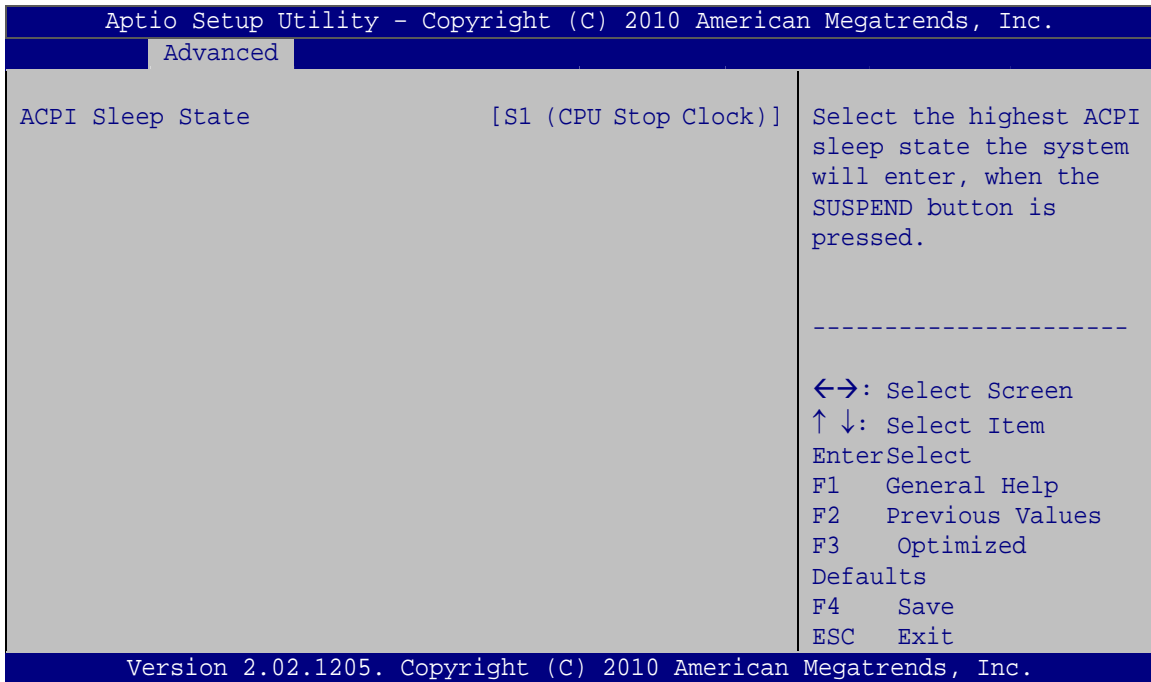

BIOS Menu 3: ACPI Configuration

→ ACPI Sleep State [S1 (CPU Stop Clock)]

Use the **ACPI Sleep State** option to specify the sleep state the system enters when it is not being used.

- **S1 (CPU Stop DEFAULT Clock)** The system enters S1(POS) sleep state. The system appears off. The CPU is stopped; RAM is refreshed; the system is running in a low power mode.
- **S3 (Suspend to RAM)** The caches are flushed and the CPU is powered off. Power to the RAM is maintained. The computer returns slower to a working state, but more power is saved.

5.3.2 RTC Wake Settings

The **RTC Wake Settings** menu (**BIOS Menu 4**) configures RTC wake event.

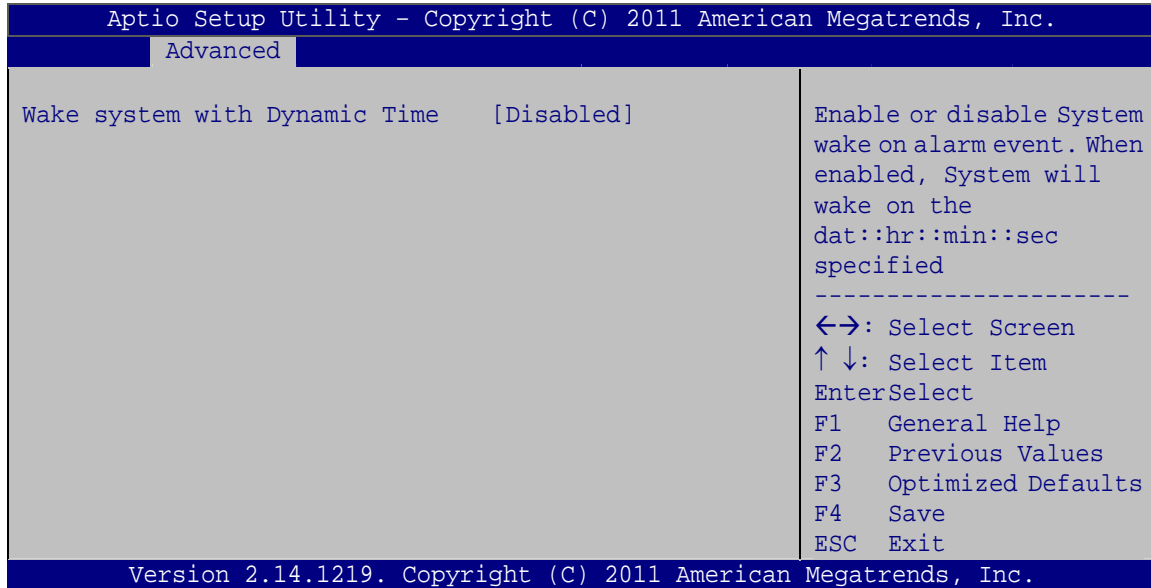

BIOS Menu 4: RTC Wake Settings

→ Wake System with Fixed Time [Disabled]

Use the **Wake System with Fixed Time** option to specify the time the system should be roused from a suspended state.

→ **Disabled** **DEFAULT** The real time clock (RTC) cannot generate a wake event

→ **Enabled** If selected, the following appears with values that can be selected:

*Wake up every day

*Wake up date

*Wake up hour

*Wake up minute

*Wake up second

After setting the alarm, the computer turns itself on from a suspend state when the alarm goes off.

5.3.3 CPU Configuration

Use the **CPU Configuration** menu (**BIOS Menu 5**) to view detailed CPU specifications and configure the CPU.

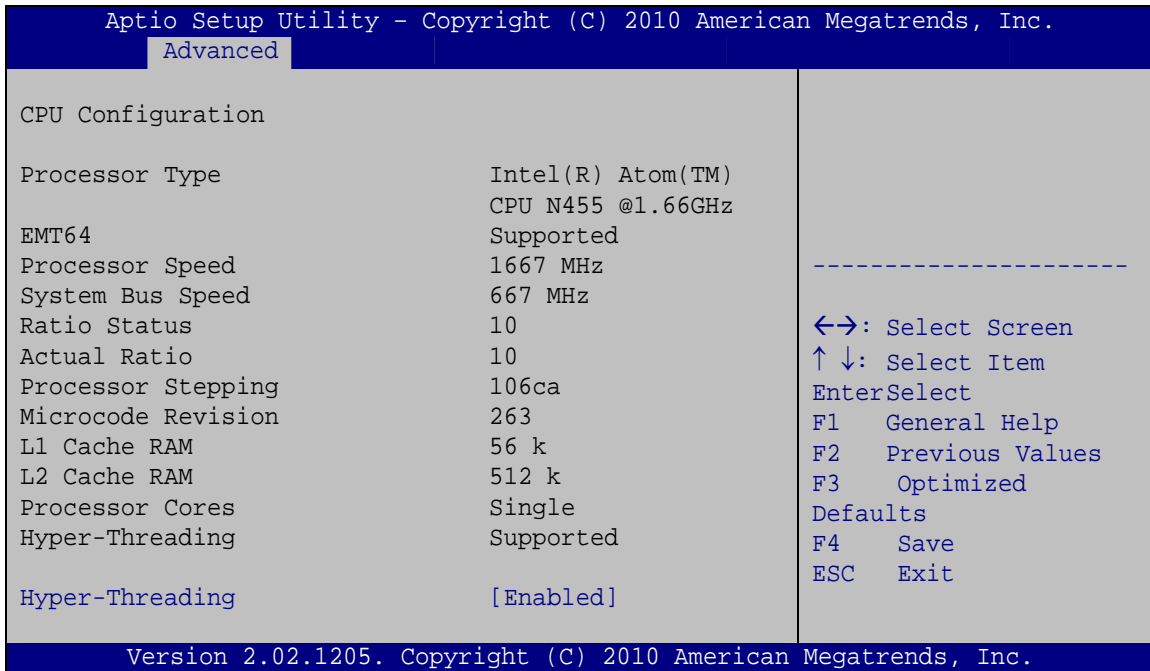

BIOS Menu 5: CPU Configuration

The CPU Configuration menu (**BIOS Menu 5**) lists the following CPU details:

- Processor Type: Lists the brand name of the CPU being used
- EMT64: Indicates if the EM64T is supported by the CPU.
- Processor Speed: Lists the CPU processing speed
- Actual Ratio: Lists the ratio of the frequency to the clock speed
- Processor Stepping: Lists the CPU processing stepping
- Microcode Revision: Lists the microcode revision
- L1 Cache RAM: Lists the CPU L1 cache size
- L2 Cache RAM: Lists the CPU L2 cache size
- Processor Cores: Lists the number of the processor core
- Hyper-Threading: Indicates if the Intel HT Technology is supported by the CPU.

WAFER-PV-D5252/D4252/N4552 SBC

→ Hyper-Threading [Enabled]

Use the **Hyper-Threading** option to enable or disable Intel Hyper-Threading technology.

- **Disabled** Disables Intel Hyper-Threading technology
- **Enabled** **DEFAULT** Enables Intel Hyper-Threading technology

5.3.4 IDE Configuration

Use the **IDE Configuration** menu (**BIOS Menu 6**) to change and/or set the configuration of the IDE devices installed in the system.

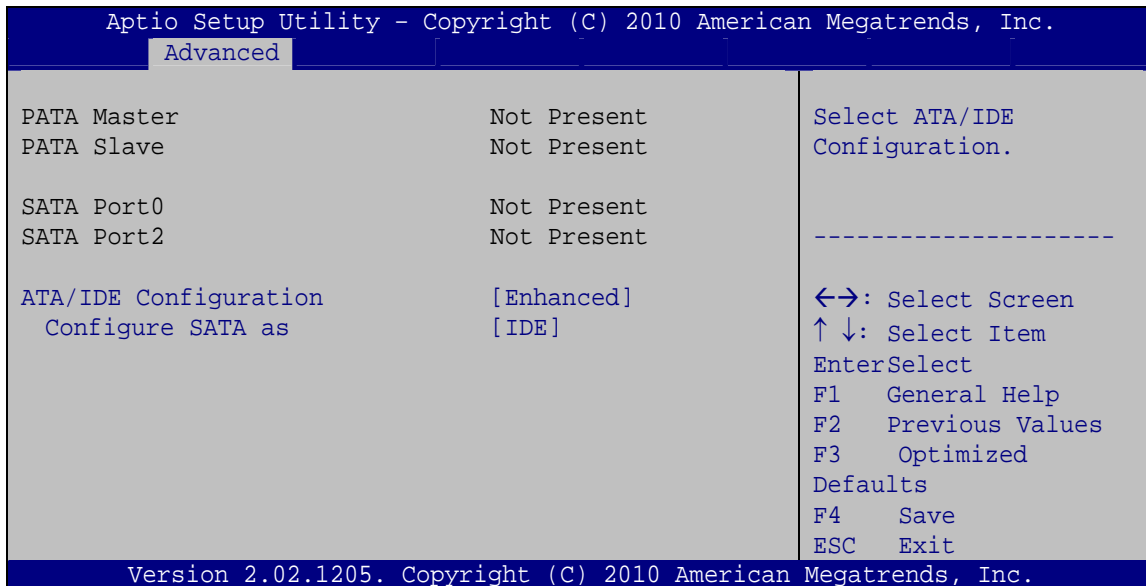

BIOS Menu 6: IDE Configuration

→ ATA/IDE Configurations [Enhanced]

Use the **ATA/IDE Configurations** option to configure the ATA/IDE controller.

- **Disabled** Disables the on-board ATA/IDE controller.

- **Compatible** Configures the on-board ATA/IDE controller to be in compatible mode. In this mode, a SATA channel will replace one of the IDE channels. This mode supports up to 4 storage devices.

- **Enhanced** **DEFAULT** Configures the on-board ATA/IDE controller to be in Enhanced mode. In this mode, IDE channels and SATA channels are separated. This mode supports up to 6 storage devices. Some legacy OS do not support this mode.

→ **Configure SATA as [IDE]**

Use the **Configure SATA as** option to configure SATA devices as normal IDE devices.

- **IDE** **DEFAULT** Configures SATA devices as normal IDE device.

- **AHCI** Configures SATA devices as normal AHCI device.

WAFER-PV-D5252/D4252/N4552 SBC

5.3.5 USB Configuration

Use the **USB Configuration** menu (**BIOS Menu 7**) to read USB configuration information and configure the USB settings.

```

Aptio Setup Utility - Copyright (C) 2010 American Megatrends, Inc.
  Advanced
-----
USB Configuration
USB Devices:
  1 Keyboard
Legacy USB Support          [Enabled]
-----
                                  Enables Legacy USB
                                  support. AUTO option
                                  disables legacy support
                                  if no USB devices are
                                  connected. DISABLE
                                  option will keep USB
                                  devices available only
                                  for EFI applications.
-----
                                  <-->: Select Screen
                                  ↑ ↓: Select Item
                                  Enter>Select
                                  F1   General Help
                                  F2   Previous Values
                                  F3   Optimized
                                  Defaults
                                  F4   Save
                                  ESC  Exit
-----
Version 2.02.1205. Copyright (C) 2010 American Megatrends, Inc.

```

BIOS Menu 7: USB Configuration

→ USB Devices

The **USB Devices Enabled** field lists the USB devices that are enabled on the system

→ Legacy USB Support [Enabled]

Use the **Legacy USB Support** BIOS option to enable USB mouse and USB keyboard support. Normally if this option is not enabled, any attached USB mouse or USB keyboard does not become available until a USB compatible operating system is fully booted with all USB drivers loaded. When this option is enabled, any attached USB mouse or USB keyboard can control the system even when there is no USB driver loaded onto the system.

- ➔ **Enabled** **DEFAULT** Legacy USB support enabled
- ➔ **Disabled** Legacy USB support disabled
- ➔ **Auto** Legacy USB support disabled if no USB devices are connected

5.3.6 Super IO Configuration

Use the **Super IO Configuration** menu (**BIOS Menu 8**) to set or change the configurations for the FDD controllers, parallel ports and serial ports.

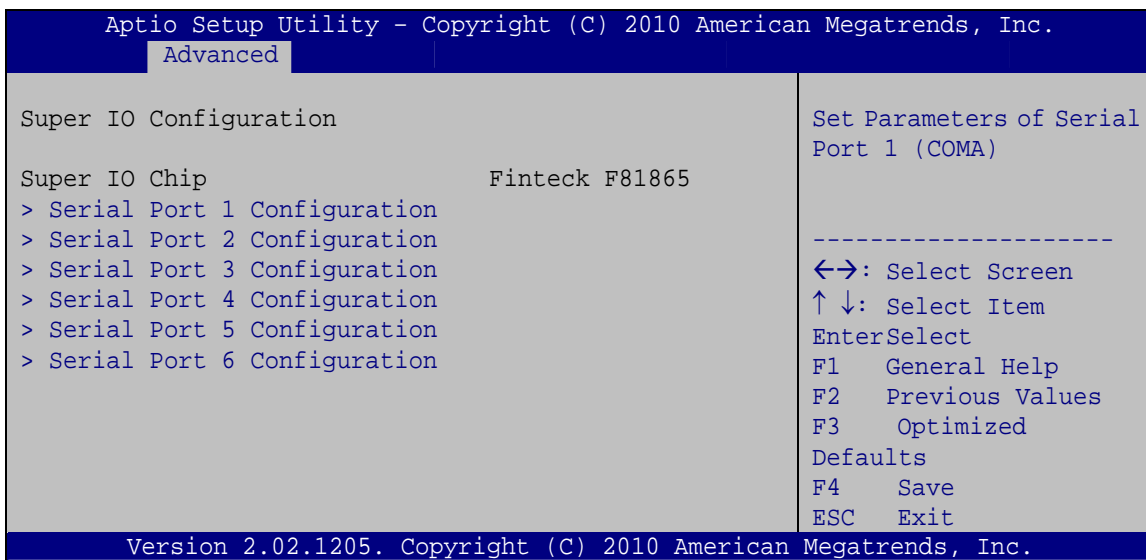

BIOS Menu 8: Super IO Configuration

WAFER-PV-D5252/D4252/N4552 SBC

5.3.6.1 Serial Port n Configuration

Use the **Serial Port n Configuration** menu (**BIOS Menu 9**) to configure the serial port n.

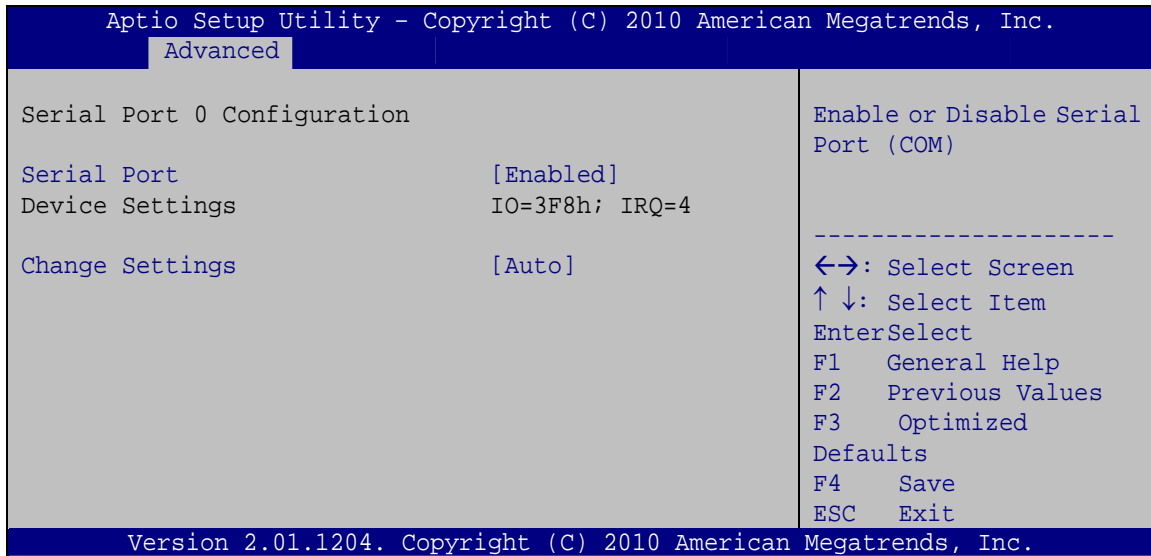

BIOS Menu 9: Serial Port n Configuration Menu

5.3.6.1.1 Serial Port 1 Configuration

→ Serial Port [Enabled]

Use the **Serial Port** option to enable or disable the serial port.

- **Disabled** Disable the serial port
- **Enabled** **DEFAULT** Enable the serial port

→ Change Settings [Auto]

Use the **Change Settings** option to change the serial port IO port address and interrupt address.

- **Auto** **DEFAULT** The serial port IO port address and interrupt address are automatically detected.
- **IO=3F8h;**
IRQ=4 Serial Port I/O port address is 3F8h and the interrupt address is IRQ4

- ➔ **IO=3F8h;**
IRQ=3, 4 Serial Port I/O port address is 3E8h and the interrupt address is IRQ3, 4
- ➔ **IO=2F8h;**
IRQ=3, 4 Serial Port I/O port address is 2F8h and the interrupt address is IRQ3, 4

5.3.6.1.2 Serial Port 2 Configuration

➔ **Serial Port [Enabled]**

Use the **Serial Port** option to enable or disable the serial port.

- ➔ **Disabled** Disable the serial port
- ➔ **Enabled** **DEFAULT** Enable the serial port

➔ **Change Settings [Auto]**

Use the **Change Settings** option to change the serial port IO port address and interrupt address.

- ➔ **Auto** **DEFAULT** The serial port IO port address and interrupt address are automatically detected.
- ➔ **IO=2F8h;**
IRQ=3 Serial Port I/O port address is 2F8h and the interrupt address is IRQ3
- ➔ **IO=3F8h;**
IRQ=3, 4 Serial Port I/O port address is 3F8h and the interrupt address is IRQ3, 4
- ➔ **IO=2F8h;**
IRQ=3, 4 Serial Port I/O port address is 2F8h and the interrupt address is IRQ3, 4

5.3.6.1.3 Serial Port 3 Configuration

➔ **Serial Port [Enabled]**

Use the **Serial Port** option to enable or disable the serial port.

- ➔ **Disabled** Disable the serial port

WAFER-PV-D5252/D4252/N4552 SBC

→ **Enabled** **DEFAULT** Enable the serial port

→ **Change Settings [Auto]**

Use the **Change Settings** option to change the serial port IO port address and interrupt address.

→ **Auto** **DEFAULT** The serial port IO port address and interrupt address are automatically detected.

→ **IO=3E8h;**
IRQ=10 Serial Port I/O port address is 3E8h and the interrupt address is IRQ10

→ **IO=3E8h;**
IRQ=10, 11 Serial Port I/O port address is 3E8h and the interrupt address is IRQ10, 11

→ **IO=2E8h;**
IRQ=10, 11 Serial Port I/O port address is 2E8h and the interrupt address is IRQ10, 11

5.3.6.1.4 Serial Port 4 Configuration

→ **Serial Port [Enabled]**

Use the **Serial Port** option to enable or disable the serial port.

→ **Disabled** Disable the serial port

→ **Enabled** **DEFAULT** Enable the serial port

→ **Change Settings [Auto]**

Use the **Change Settings** option to change the serial port IO port address and interrupt address.

→ **Auto** **DEFAULT** The serial port IO port address and interrupt address are automatically detected.

→ **IO=2E8h;**
IRQ=10 Serial Port I/O port address is 2E8h and the interrupt address is IRQ10

- ➔ **IO=3E8h;**
IRQ=10, 11 Serial Port I/O port address is 3E8h and the interrupt address is IRQ10, 11
- ➔ **IO=2E8h;**
IRQ=10, 11 Serial Port I/O port address is 2E8h and the interrupt address is IRQ10, 11

5.3.6.1.5 Serial Port 5 Configuration

➔ Serial Port [Enabled]

Use the **Serial Port** option to enable or disable the serial port.

- ➔ **Disabled** Disable the serial port
- ➔ **Enabled** **DEFAULT** Enable the serial port

➔ Change Settings [Auto]

Use the **Change Settings** option to change the serial port IO port address and interrupt address.

- ➔ **Auto** **DEFAULT** The serial port IO port address and interrupt address are automatically detected.
- ➔ **IO=2C0h;**
IRQ=11 Serial Port I/O port address is 2C0h and the interrupt address is IRQ11
- ➔ **IO=2C0h;**
IRQ=10, 11 Serial Port I/O port address is 2C0h and the interrupt address is IRQ10, 11
- ➔ **IO=2C8h;**
IRQ=10, 11 Serial Port I/O port address is 2C8h and the interrupt address is IRQ10, 11

WAFER-PV-D5252/D4252/N4552 SBC

5.3.6.1.6 Serial Port 6 Configuration

→ Serial Port [Enabled]

Use the **Serial Port** option to enable or disable the serial port.

- **Disabled** Disable the serial port
- **Enabled** **DEFAULT** Enable the serial port

→ Change Settings [Auto]

Use the **Change Settings** option to change the serial port IO port address and interrupt address.

- **Auto** **DEFAULT** The serial port IO port address and interrupt address are automatically detected.
- **IO=2C8h;**
IRQ=10 Serial Port I/O port address is 2C8h and the interrupt address is IRQ10
- **IO=2C0h;**
IRQ=10, 11 Serial Port I/O port address is 2C0h and the interrupt address is IRQ10, 11
- **IO=2C8h;**
IRQ=10, 11 Serial Port I/O port address is 2C8h and the interrupt address is IRQ10, 11

5.3.7 H/W Monitor

The H/W Monitor menu (**BIOS Menu 10**) shows the operating temperature, fan speeds and system voltages.

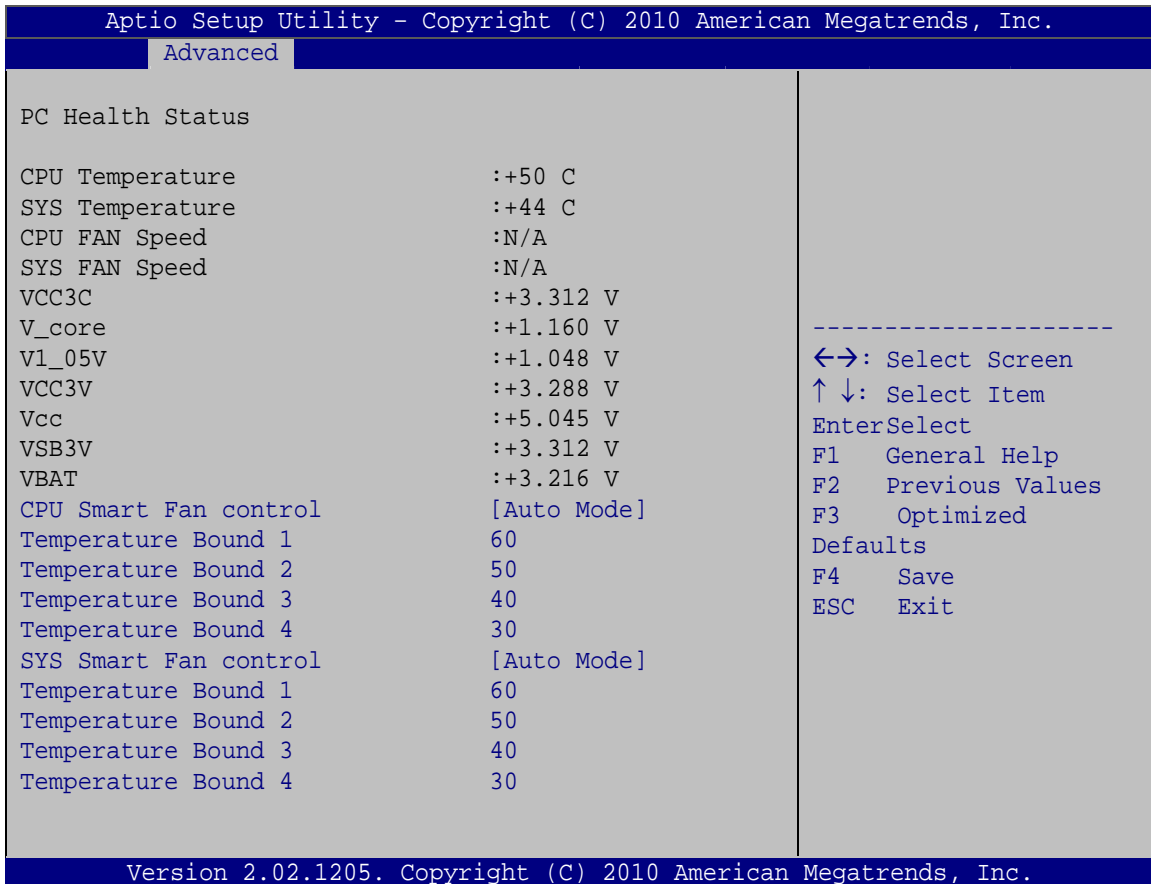

BIOS Menu 10: Hardware Health Configuration

➔ PC Health Status

The following system parameters and values are shown. The system parameters that are monitored are:

- System Temperatures:
 - CPU Temperature
 - System Temperature
- Fan Speeds:
 - CPU Fan Speed
 - System Fan Speed

WAFER-PV-D5252/D4252/N4552 SBC

- Voltages:
 - VCC3V
 - V_core
 - V1_05V
 - VCC3V
 - Vcc
 - VSB3V
 - VBAT

→ CPU Smart Fan control [Auto Mode]

Use the **CPU Smart Fan control** option to configure the CPU fan.

→ Auto Mode

The fan adjusts its speed using these settings:

Temperature Bound 1

Temperature Bound 2

Temperature Bound 3

Temperature Bound 4

→ Manual Mode

The fan spins at the speed set in:

Manual Duty Cycle Setting

5.3.8 Serial Port Console Redirection

The **Serial Port Console Redirection** menu (**BIOS Menu 11**) allows the console redirection options to be configured. Console redirection allows users to maintain a system remotely by re-directing keyboard input and text output through the serial port.

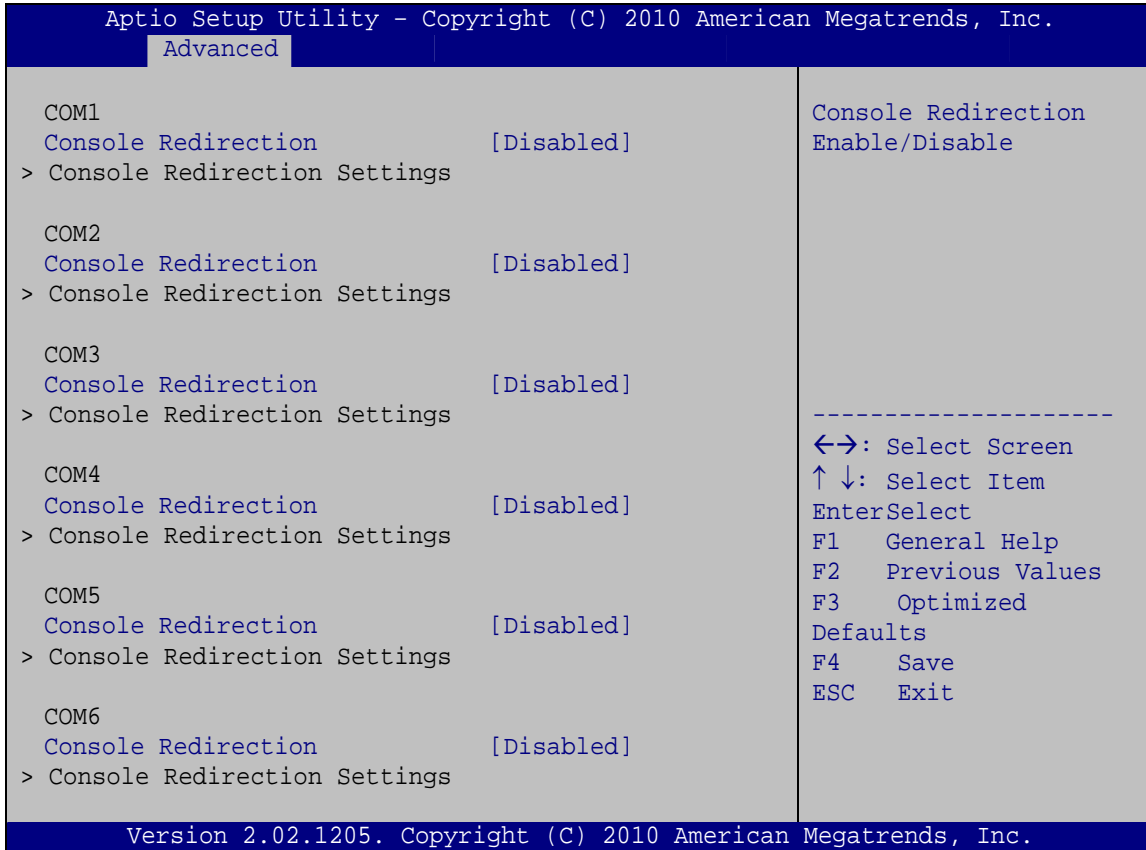

BIOS Menu 11: Serial Port Console Redirection

➔ **Console Redirection [Disabled]**

Use **Console Redirection** option to enable or disable the console redirection function.

- ➔ **Disabled** **DEFAULT** Disabled the console redirection function
- ➔ **Enabled** Enabled the console redirection function

5.3.9 IEI Feature

Use the **IEI Feature** menu (**BIOS Menu 12**) to configure One Key Recovery function.

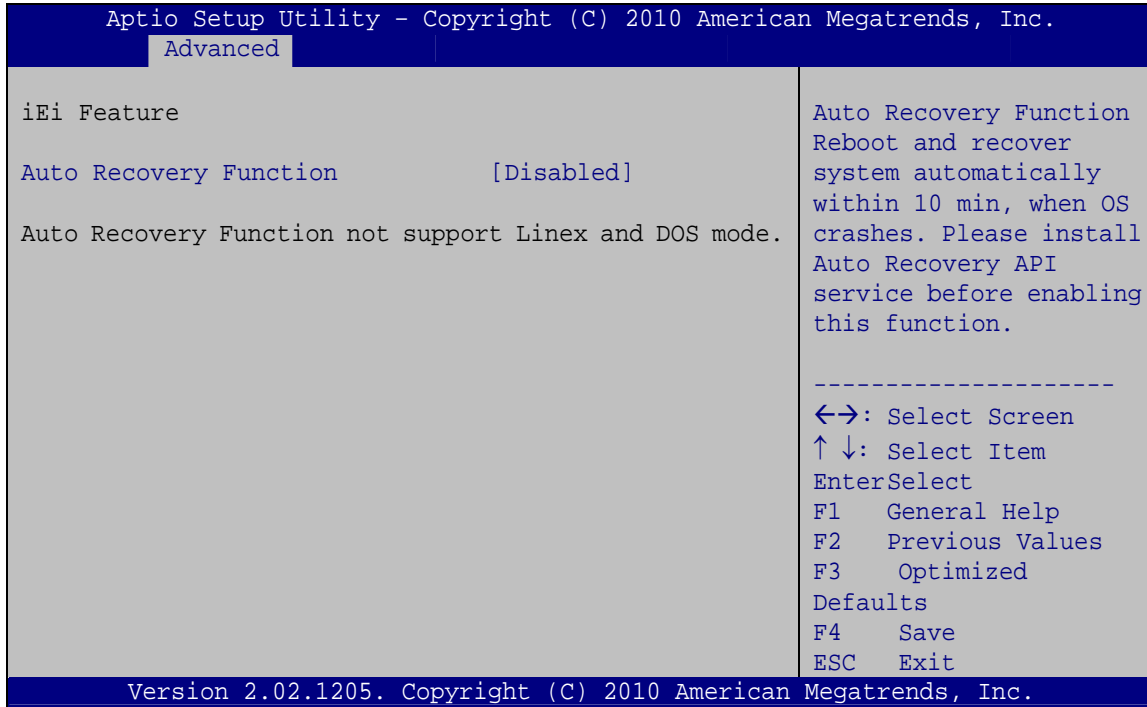

BIOS Menu 12: IEI Feature

➔ Auto Recovery Function [Disabled]

Use the **Auto Recovery Function** BIOS option to enable or disable the auto recovery function of the IEI One Key Recovery.

- ➔ **Disabled** **DEFAULT** Auto recovery function disabled
- ➔ **Enabled** Auto recovery function enabled

5.4 Chipset

Use the **Chipset** menu (**BIOS Menu 13**) to access the Northbridge and Southbridge configuration menus



WARNING!

Setting the wrong values for the Chipset BIOS selections in the Chipset BIOS menu may cause the system to malfunction.

```
Aptio Setup Utility - Copyright (C) 2010 American Megatrends, Inc.
Main   Advanced  Chipset  Boot   Security  Save & Exit
-----
> Host Bridge                Host Bridge Parameters
> South Bridge
> Intel IGD SWSCI OpRegion

-----
<=>: Select Screen
↑↓: Select Item
Enter>Select
F1   General Help
F2   Previous Values
F3   Optimized
Defaults
F4   Save
ESC  Exit

Version 2.02.1205. Copyright (C) 2010 American Megatrends, Inc.
```

BIOS Menu 13: Chipset

WAFER-PV-D5252/D4252/N4552 SBC

5.4.1 Host Bridge

Use the **Host Bridge** menu (**BIOS Menu 14**) to configure the host bridge chipset.

```

Aptio Setup Utility - Copyright (C) 2010 American Megatrends, Inc.
  Chipset
***** Memory Information *****
Memory Frequency           667 Mhz
Total Memory               2048 MB
DIMM#0                     2048 MB
DIMM#1                     Not present
Config On Chip VGA
Settings
-----
<->: Select Screen
↑ ↓: Select Item
EnterSelect
F1   General Help
F2   Previous Values
F3   Optimized
Defaults
F4   Save
ESC  Exit
Version 2.02.1205. Copyright (C) 2010 American Megatrends, Inc.
  
```

BIOS Menu 14:Host Bridge Configuration

5.4.2 South Bridge

Use the **South Bridge** menu (**BIOS Menu 15**) to configure the Southbridge chipset.

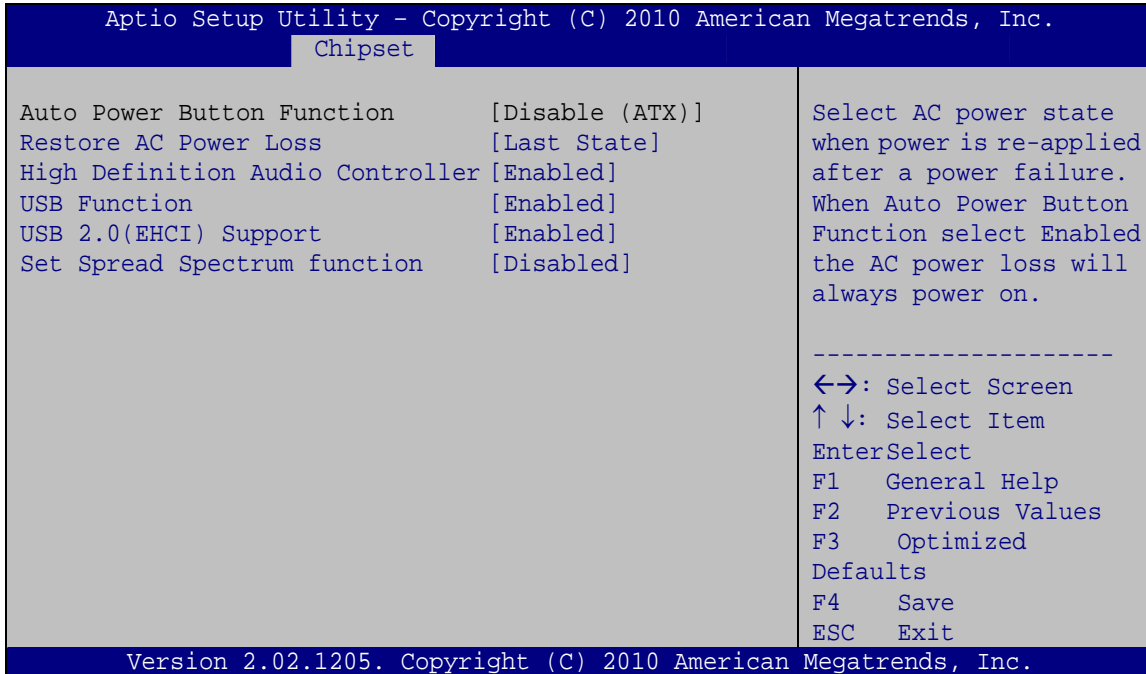

BIOS Menu 15:Southbridge Chipset Configuration

→ Restore on AC Power Loss [Last State]

Use the **Restore on AC Power Loss** BIOS option to specify what state the system returns to if there is a sudden loss of power to the system.

- **Power Off** The system remains turned off
- **Power On** The system turns on
- **Last State** **DEFAULT** The system returns to its previous state. If it was on, it turns itself on. If it was off, it remains off.

→ High Definition Audio Controller [Enabled]

The **High Definition Audio Controller** option enables or disables the HD audio controller.

WAFER-PV-D5252/D4252/N4552 SBC

→ **Enabled** **DEFAULT** The onboard HD audio controller automatically detected and enabled

→ **Disabled** The onboard HD audio controller is disabled

→ **USB Function [Enabled]**

Use the **USB Function** BIOS option to enable or disable USB function support.

→ **Disabled** USB function support disabled

→ **Enabled** **DEFAULT** USB function support enabled

→ **USB 2.0 (EHCI) Support [Enabled]**

Use the **USB 2.0 (EHCI) Support** BIOS option to enable or disable the USB 2.0 controller.

→ **Enabled** **DEFAULT** USB 2.0 controller enabled

→ **Disabled** USB 2.0 controller disabled

→ **Set Spread Spectrum Function [Disabled]**

The **Set Spread Spectrum Function** option can help to improve CPU EMI issues.

→ **Disabled** **DEFAULT** The spread spectrum function is disabled

→ **Enabled** The spread spectrum function is enabled

5.4.3 Intel IGD SWSCI OpRegion

Use the **Intel IGD SWSCI OpRegion** menu (**BIOS Menu 16**) to configure the video device connected to the system.

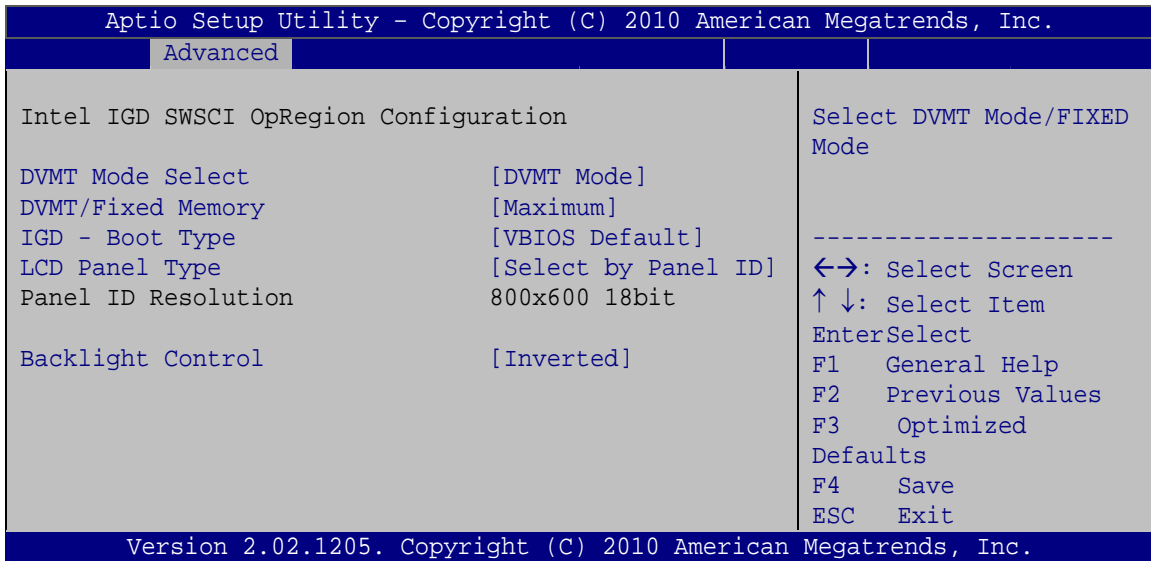

BIOS Menu 16: Intel IGD SWSCI OpRegion

➔ DVMT Mode Select [DVMT Mode]

Use the **DVMT Mode Select** option to select the Intel Dynamic Video Memory Technology (DVMT) operating mode.

- ➔ **Fixed Mode** A fixed portion of graphics memory is reserved as graphics memory.
- ➔ **DVMT Mode** **DEFAULT** Graphics memory is dynamically allocated according to the system and graphics needs.

➔ DVMT/FIXED Memory [Maximum]

Use the **DVMT/FIXED Memory** option to specify the maximum amount of memory that can be allocated as graphics memory. Configuration options are listed below.

- 128 MB
- 256 MB
- Maximum **DEFAULT**

WAFER-PV-D5252/D4252/N4552 SBC**→ IGD - Boot Type [VBIOS Default]**

Use the **IGD - Boot Type** option to select the display device used by the system when it boots. Configuration options are listed below.

- VBIOS Default **DEFAULT**
- CRT
- LFP
- CRT + LFP

→ LCD Panel Type [VBIOS Default]

Use the **LCD Panel Type** option to select the type of flat panel connected to the system. Configuration options are listed below.

- Select by Panel ID **DEFAULT**
- 640x480 18bit
- 800x480 18bit
- 800x600 18bit
- 1024x768 18bit
- 1280x1024 18bit
- 1366x768 18bit
- 1280x800 18bit
- 1280x600 18bit

→ Backlight Control [Inverted]

Use the **Backlight Control** option to select the backlight control mode.

- **Normal** Brightest at low voltage level
- **Inverted** **DEFAULT** Brightest at high voltage level

5.5 Boot

Use the **Boot** menu (**BIOS Menu 17**) to configure system boot options.

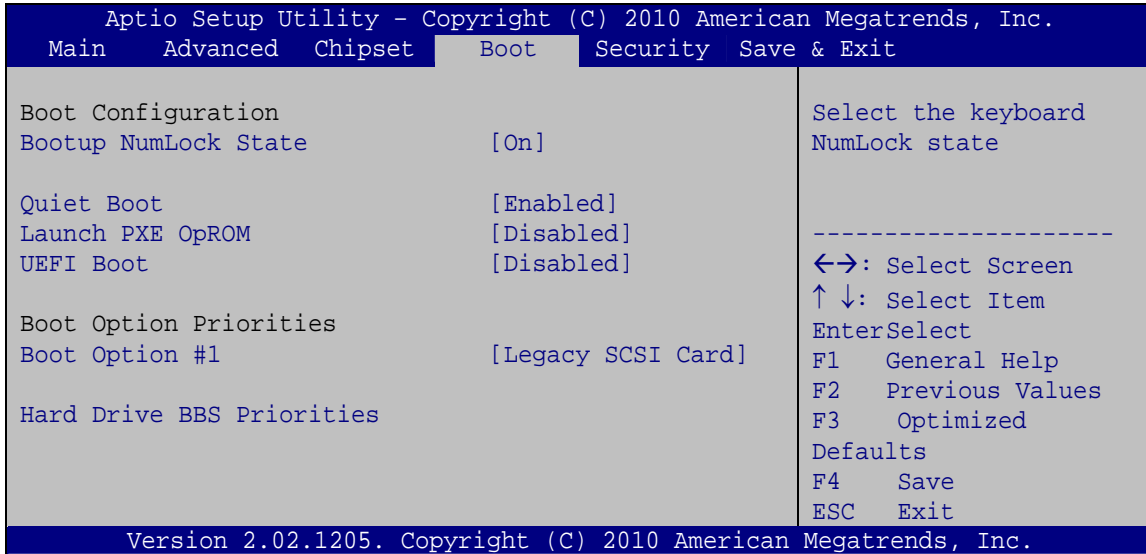

BIOS Menu 17: Boot

→ Bootup NumLock State [On]

Use the **Bootup NumLock State** BIOS option to specify if the number lock setting must be modified during boot up.

→ **On** **DEFAULT** Allows the Number Lock on the keyboard to be enabled automatically when the computer system boots up. This allows the immediate use of the 10-key numeric keypad located on the right side of the keyboard. To confirm this, the Number Lock LED light on the keyboard is lit.

→ **Off** Does not enable the keyboard Number Lock automatically. To use the 10-keys on the keyboard, press the Number Lock key located on the upper left-hand corner of the 10-key pad. The Number Lock LED on the keyboard lights up when the Number Lock is engaged.

WAFER-PV-D5252/D4252/N4552 SBC**→ Quiet Boot [Enabled]**

Use the **Quiet Boot** BIOS option to select the screen display when the system boots.

- **Disabled** Normal POST messages displayed
- **Enabled** **DEFAULT** OEM Logo displayed instead of POST messages

→ Launch PXE OpROM [Disabled]

Use the **Launch PXE OpROM** option to enable or disable boot option for legacy network devices.

- **Disabled** **DEFAULT** Ignore all PXE Option ROMs
- **Enabled** Load PXE Option ROMs.

→ UEFI Boot [Disabled]

Use the **UEFI Boot** option to enable or disable to boot from a UEFI device.

- **Enabled** Enable to boot from a UEFI device.
- **Disabled** **DEFAULT** Disable to boot from a UEFI device.

5.6 Security

Use the **Security** menu (**BIOS Menu 18**) to set system and user passwords.

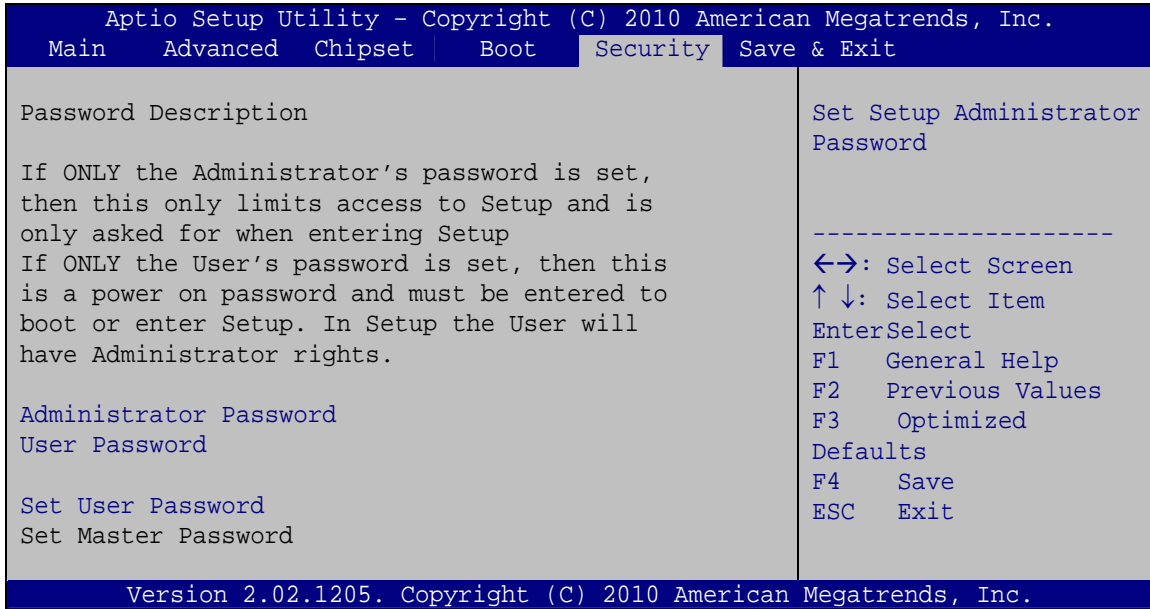

BIOS Menu 18: Security

→ Administrator Password

Use the **Administrator Password** to set or change a administrator password.

→ User Password

Use the **User Password** to set or change a user password.

5.7 Exit

Use the **Exit** menu (**BIOS Menu 19**) to load default BIOS values, optimal failsafe values and to save configuration changes.

WAFER-PV-D5252/D4252/N4552 SBC

```

Aptio Setup Utility - Copyright (C) 2010 American Megatrends, Inc.
Main   Advanced  Chipset  Boot   Security  Save & Exit
-----
Save Changes and Reset
Discard Changes and Reset

Restore Defaults
Save as User Defaults
Restore User Defaults

Reset the system after
saving the changes.

-----
<->: Select Screen
↑ ↓: Select Item
Enter>Select
F1   General Help
F2   Previous Values
F3   Optimized
Defaults
F4   Save
ESC  Exit

Version 2.01.1204. Copyright (C) 2010 American Megatrends, Inc.

```

BIOS Menu 19:Exit

→ Save Changes and Reset

Use the **Save Changes and Reset** option to save the changes made to the BIOS options and to exit the BIOS configuration setup program.

→ Discard Changes and Reset

Use the **Discard Changes and Reset** option to exit the system without saving the changes made to the BIOS configuration setup program.

→ Restore Defaults

Use the **Restore Defaults** option to load the optimal default values for each of the parameters on the Setup menus. **F3 key can be used for this operation.**

→ Save as User Defaults

Use the **Save as User Defaults** option to save the changes done so far as user defaults.

→ Restore User Defaults

Use the **Restore User Defaults** option to restore the user defaults to all the setup options.

Appendix

A

Regulatory Compliance

DECLARATION OF CONFORMITY

This equipment has been tested and found to comply with specifications for CE marking. If the user modifies and/or installs other devices in the equipment, the CE conformity declaration may no longer apply.

FCC WARNING

This equipment complies with Part 15 of the FCC Rules. Operation is subject to the following two conditions:

- This device may not cause harmful interference, and
- This device must accept any interference received, including interference that may cause undesired operation.

This equipment has been tested and found to comply with the limits for a Class A digital device, pursuant to part 15 of the FCC Rules. These limits are designed to provide reasonable protection against harmful interference when the equipment is operated in a commercial environment. This equipment generates, uses, and can radiate radio frequency energy and, if not installed and used in accordance with the instruction manual, may cause harmful interference to radio communications. Operation of this equipment in a residential area is likely to cause harmful interference in which case the user will be required to correct the interference at his own expense.

Appendix

B

BIOS Options

WAFER-PV-D5252/D4252/N4552 SBC

Below is a list of BIOS configuration options in the BIOS chapter.

BIOS Information	64
System Date [xx/xx/xx]	65
System Time [xx:xx:xx]	65
ACPI Sleep State [S1 (CPU Stop Clock)]	66
Wake System with Fixed Time [Disabled]	67
Hyper-Threading [Enabled]	69
ATA/IDE Configurations [Enhanced]	69
Configure SATA as [IDE]	70
USB Devices	71
Legacy USB Support [Enabled]	71
Serial Port [Enabled]	73
Change Settings [Auto]	73
Serial Port [Enabled]	74
Change Settings [Auto]	74
Serial Port [Enabled]	74
Change Settings [Auto]	75
Serial Port [Enabled]	75
Change Settings [Auto]	75
Serial Port [Enabled]	76
Change Settings [Auto]	76
Serial Port [Enabled]	77
Change Settings [Auto]	77
PC Health Status	78
CPU Smart Fan control [Auto Mode]	79
Console Redirection [Disabled]	80
Auto Recovery Function [Disabled]	81
Restore on AC Power Loss [Last State]	84
High Definition Audio Controller [Enabled]	84
USB Function [Enabled]	85
USB 2.0 (EHCI) Support [Enabled]	85
Set Spread Spectrum Function [Disabled]	85
DVMT Mode Select [DVMT Mode]	86
DVMT/FIXED Memory [Maximum]	86

IGD - Boot Type [VBIOS Default].....	87
LCD Panel Type [VBIOS Default].....	87
Backlight Control [Inverted].....	87
Bootup NumLock State [On].....	88
Quiet Boot [Enabled]	89
Launch PXE OpROM [Disabled]	89
UEFI Boot [Disabled]	89
Administrator Password	90
User Password	90
Save Changes and Reset	91
Discard Changes and Reset	91
Restore Defaults	91
Save as User Defaults	91
Restore User Defaults	91

Appendix

C

Terminology

AC '97	Audio Codec 97 (AC'97) refers to a codec standard developed by Intel® in 1997.
ACPI	Advanced Configuration and Power Interface (ACPI) is an OS-directed configuration, power management, and thermal management interface.
AHCI	Advanced Host Controller Interface (AHCI) is a SATA Host controller register-level interface.
ATA	The Advanced Technology Attachment (ATA) interface connects storage devices including hard disks and CD-ROM drives to a computer.
ARMD	An ATAPI Removable Media Device (ARMD) is any ATAPI device that supports removable media, besides CD and DVD drives.
ASKIR	Amplitude Shift Keyed Infrared (ASKIR) is a form of modulation that represents a digital signal by varying the amplitude (“volume”) of the signal. A low amplitude signal represents a binary 0, while a high amplitude signal represents a binary 1.
BIOS	The Basic Input/Output System (BIOS) is firmware that is first run when the computer is turned on and can be configured by the end user
CODEC	The Compressor-Decompressor (CODEC) encodes and decodes digital audio data on the system.
CompactFlash®	CompactFlash® is a solid-state storage device. CompactFlash® devices use flash memory in a standard size enclosure. Type II is thicker than Type I, but a Type II slot can support both types.
CMOS	Complimentary metal-oxide-conductor is an integrated circuit used in chips like static RAM and microprocessors.
COM	COM refers to serial ports. Serial ports offer serial communication to expansion devices. The serial port on a personal computer is usually a male DB-9 connector.
DAC	The Digital-to-Analog Converter (DAC) converts digital signals to analog signals.
DDR	Double Data Rate refers to a data bus transferring data on both the rising and falling edges of the clock signal.

WAFER-PV-D5252/D4252/N4552 SBC

DMA	Direct Memory Access (DMA) enables some peripheral devices to bypass the system processor and communicate directly with the system memory.
DIMM	Dual Inline Memory Modules are a type of RAM that offer a 64-bit data bus and have separate electrical contacts on each side of the module.
DIO	The digital inputs and digital outputs are general control signals that control the on/off circuit of external devices or TTL devices. Data can be read or written to the selected address to enable the DIO functions.
EHCI	The Enhanced Host Controller Interface (EHCI) specification is a register-level interface description for USB 2.0 Host Controllers.
EIDE	Enhanced IDE (EIDE) is a newer IDE interface standard that has data transfer rates between 4.0 MBps and 16.6 MBps.
EIST	Enhanced Intel® SpeedStep Technology (EIST) allows users to modify the power consumption levels and processor performance through application software. The application software changes the bus-to-core frequency ratio and the processor core voltage.
FSB	The Front Side Bus (FSB) is the bi-directional communication channel between the processor and the Northbridge chipset.
GbE	Gigabit Ethernet (GbE) is an Ethernet version that transfers data at 1.0 Gbps and complies with the IEEE 802.3-2005 standard.
GPIO	General purpose input
HDD	Hard disk drive (HDD) is a type of magnetic, non-volatile computer storage device that stores digitally encoded data.
ICH	The Input/Output Control Hub (ICH) is an Intel® Southbridge chipset.
IrDA	Infrared Data Association (IrDA) specify infrared data transmission protocols used to enable electronic devices to wirelessly communicate with each other.
L1 Cache	The Level 1 Cache (L1 Cache) is a small memory cache built into the system processor.
L2 Cache	The Level 2 Cache (L2 Cache) is an external processor memory cache.

LCD	Liquid crystal display (LCD) is a flat, low-power display device that consists of two polarizing plates with a liquid crystal panel in between.
LVDS	Low-voltage differential signaling (LVDS) is a dual-wire, high-speed differential electrical signaling system commonly used to connect LCD displays to a computer.
POST	The Power-on Self Test (POST) is the pre-boot actions the system performs when the system is turned-on.
RAM	Random Access Memory (RAM) is volatile memory that loses data when power is lost. RAM has very fast data transfer rates compared to other storage like hard drives.
SATA	Serial ATA (SATA) is a serial communications bus designed for data transfers between storage devices and the computer chipsets. The SATA bus has transfer speeds up to 1.5 Gbps and the SATA II bus has data transfer speeds of up to 3.0 Gbps.
S.M.A.R.T	Self Monitoring Analysis and Reporting Technology (S.M.A.R.T) refers to automatic status checking technology implemented on hard disk drives.
UART	Universal Asynchronous Receiver-transmitter (UART) is responsible for asynchronous communications on the system and manages the system's serial communication (COM) ports.
UHCI	The Universal Host Controller Interface (UHCI) specification is a register-level interface description for USB 1.1 Host Controllers.
USB	The Universal Serial Bus (USB) is an external bus standard for interfacing devices. USB 1.1 supports 12Mbps data transfer rates and USB 2.0 supports 480Mbps data transfer rates.
VGA	The Video Graphics Array (VGA) is a graphics display system developed by IBM.

Appendix

D

Digital I/O Interface

D.1 Introduction

The DIO connector on the WAFER-PV-D5252/D4252/N4552 is interfaced to GPIO ports on the Super I/O chipset. The DIO has both 4-bit digital inputs and 4-bit digital outputs. The digital inputs and digital outputs are generally control signals that control the on/off circuit of external devices or TTL devices. Data can be read or written to the selected address to enable the DIO functions.



NOTE:

For further information, please refer to the datasheet for the Super I/O chipset.

The BIOS interrupt call **INT 15H** controls the digital I/O.

INT 15H:

AH – 6FH
<u>Sub-function:</u>
AL – 8 : Set the digital port as INPUT
AL : Digital I/O input value

WAFER-PV-D5252/D4252/N4552 SBC

D.2 Assembly Language Sample 1

```

MOV     AX, 6F08H      ;setting the digital port as input
INT     15H           ;

```

AL low byte = value

AH – 6FH
<u>Sub-function:</u>
AL – 9 : Set the digital port as OUTPUT
BL : Digital I/O input value

D.3 Assembly Language Sample 2

```

MOV     AX, 6F09H      ;setting the digital port as output
MOV     BL, 09H        ;digital value is 09H
INT     15H           ;

```

Digital Output is 1001b

Appendix

E

Hazardous Materials Disclosure

E.1 Hazardous Materials Disclosure Table for IPB Products Certified as RoHS Compliant Under 2002/95/EC Without Mercury

The details provided in this appendix are to ensure that the product is compliant with the Peoples Republic of China (China) RoHS standards. The table below acknowledges the presences of small quantities of certain materials in the product, and is applicable to China RoHS only.

A label will be placed on each product to indicate the estimated “Environmentally Friendly Use Period” (EFUP). This is an estimate of the number of years that these substances would “not leak out or undergo abrupt change.” This product may contain replaceable sub-assemblies/components which have a shorter EFUP such as batteries and lamps. These components will be separately marked.

Please refer to the table on the next page.

Part Name	Toxic or Hazardous Substances and Elements					
	Lead (Pb)	Mercury (Hg)	Cadmium (Cd)	Hexavalent Chromium (CR(VI))	Polybrominated Biphenyls (PBB)	Polybrominated Diphenyl Ethers (PBDE)
Housing	<input type="radio"/>	<input type="radio"/>	<input type="radio"/>	<input type="radio"/>	<input type="radio"/>	<input type="radio"/>
Display	<input type="radio"/>	<input type="radio"/>	<input type="radio"/>	<input type="radio"/>	<input type="radio"/>	<input type="radio"/>
Printed Circuit Board	<input type="radio"/>	<input type="radio"/>	<input type="radio"/>	<input type="radio"/>	<input type="radio"/>	<input type="radio"/>
Metal Fasteners	<input type="radio"/>	<input type="radio"/>	<input type="radio"/>	<input type="radio"/>	<input type="radio"/>	<input type="radio"/>
Cable Assembly	<input type="radio"/>	<input type="radio"/>	<input type="radio"/>	<input type="radio"/>	<input type="radio"/>	<input type="radio"/>
Fan Assembly	<input type="radio"/>	<input type="radio"/>	<input type="radio"/>	<input type="radio"/>	<input type="radio"/>	<input type="radio"/>
Power Supply Assemblies	<input type="radio"/>	<input type="radio"/>	<input type="radio"/>	<input type="radio"/>	<input type="radio"/>	<input type="radio"/>
Battery	<input type="radio"/>	<input type="radio"/>	<input type="radio"/>	<input type="radio"/>	<input type="radio"/>	<input type="radio"/>

O: This toxic or hazardous substance is contained in all of the homogeneous materials for the part is below the limit requirement in SJ/T11363-2006

X: This toxic or hazardous substance is contained in at least one of the homogeneous materials for this part is above the limit requirement in SJ/T11363-2006

WAFER-PV-D5252/D4252/N4552 SBC

此附件旨在确保本产品符合中国 RoHS 标准。以下表格标示此产品中某有毒物质的含量符合中国 RoHS 标准规定的限量要求。

本产品上会附有“环境友好使用期限”的标签，此期限是估算这些物质“不会有泄漏或突变”的年限。本产品可能包含有较短的环境友好使用期限的可替换元件，像是电池或灯管，这些元件将会单独标示出来。

部件名称	有毒有害物质或元素					
	铅 (Pb)	汞 (Hg)	镉 (Cd)	六价铬 (CR(VI))	多溴联苯 (PBB)	多溴二苯 醚 (PBDE)
壳体	○	○	○	○	○	○
显示	○	○	○	○	○	○
印刷电路板	○	○	○	○	○	○
金属螺帽	○	○	○	○	○	○
电缆组装	○	○	○	○	○	○
风扇组装	○	○	○	○	○	○
电力供应组装	○	○	○	○	○	○
电池	○	○	○	○	○	○

○: 表示该有毒有害物质在该部件所有物质材料中的含量均在 SJ/T11363-2006 标准规定的限量要求以下。
 X: 表示该有毒有害物质至少在该部件的某一均质材料中的含量超出 SJ/T11363-2006 标准规定的限量要求。