

# VC19G+/VC19E+

---

## MAINBOARD MANUAL

DOC No.: M02A02/M02A03

Rev. : A0

Date : 11, 2002

Part No. : 25-10655-00

## Notice

### Handling Precautions

#### Warning:

1. Static electricity may cause damage to the integrated circuits on the motherboard. Before handling any motherboard outside of its protective packaging, ensure that there is no static electric charge in your body.
2. There is a danger of explosion if the battery is incorrectly replaced. Replace only with the same or an equivalent type recommended by the manufacturer.
3. Discard used batteries according to the manufacturer's instructions.
4. Never run the processor without the heatsink properly and firmly attached. PERMANENT DAMAGE WILL RESULT!

Observe the following basic precautions when handling the motherboard or other computer components:

- Wear a static wrist strap which fits around your wrist and is connected to a natural earth ground.
- Touch a grounded or anti-static surface or a metal fixture such as a water pipe.
- Avoid contacting the components on add-on cards, motherboards, and modules with the *golden fingers* connectors plugged into the expansion slot. It is best to handle system components by their mounting brackets.

The above methods prevent static build-up and cause it to be discharged properly.

### Trademark

*All trademarks mentioned in this manual are registered properly of the respective owners.*

### Handling Precautions

*This manual may not, in whole or in part, be photocopied, reproduced, transcribed, translated, or transmitted in whatever form without the written consent of the manufacturer, except for copies retained by the purchaser for personal archival purposes.*

---

<b>Quick Reference (German)</b>	<b>G-1</b>
<b>Quick Reference (French)</b>	<b>F-1</b>
<b>Quick Reference (Spanish)</b>	<b>S-1</b>
<b>Quick Reference (Japanese)</b>	<b>J-1</b>
<b>Quick Reference (Chinese)</b>	<b>C-1</b>
<b>Quick Reference (Simplified Chinese)</b>	<b>SC-1</b>

## **Chapter 1 Overview**

Package Checklist .....	1-2
The VC19G+/VC19E+ Mainboard .....	1-3
Main Features .....	1-4
FIC Unique Innovation for Users (NOVUS) - Enhanced Mainboard Features and System Support .....	1-6

## **Chapter 2 Installation Procedures**

Quick Reference (from Page 2-2 to 2-4) .....	2-2
Mainboard Layout .....	2-2
1). Clear CMOS .....	2-3
2). Front Panel Block Cable Connection .....	2-3
3). CPU Fan Installation .....	2-4
1). Set System Jumpers .....	2-4
Clear CMOS: CLR_CMOS .....	2-4
2). Install Memory Modules .....	2-5
3). Install the CPU .....	2-6
4). Install Expansion Cards .....	2-7
5). Connect Devices .....	2-8
Floppy Diskette Drive Connector .....	2-8
IDE Device Connectors .....	2-9
Fan Connectors .....	2-9
Wake-On-LAN Connector .....	2-10
Wake-On-Ring Connector .....	2-10
Power Connectors .....	2-11
CD Audio-In Connector .....	2-11

Front Panel Block and IR Connector .....	2-12
SIRQ Connector .....	2-13
IEEE 1394 Connectors (optional) .....	2-14
Serial ATA Connectors (optional) .....	2-14
Serial Port Connectors .....	2-15
PS/2 Keyboard and Mouse Connector .....	2-15
Universal Serial Bus Connectors .....	2-15
LAN Connector (optional) .....	2-16
Audio I/O Jacks .....	2-16
Printer Connector .....	2-18
Video Graphics Accelerator Connector (VC19G+ only) .....	2-18

### **Chapter 3 BIOS Setup**

CMOS Setup Utility .....	3-1
Standard CMOS Setup .....	3-2
Advanced BIOS Features .....	3-4
Advanced Chipset Features .....	3-8
Integrated Peripherals .....	3-11
Power Management Setup .....	3-15
PnP/PCI Configurations .....	3-19
PC Health Status .....	3-20
Frequency/Voltage Control .....	3-21
Load Fail-Safe Defaults .....	3-22
Load Optimized Defaults .....	3-22
Supervisor/User Password .....	3-22
Save and Exit Setup .....	3-22
Exit without Saving .....	3-22

## Overview

The new ATX, 478-pin 1stMainboard® supports a full range of the latest generation Intel® Pentium® 4 processors. The leading edge Intel® chipset was designed for working with Pentium® 4 (up to 3.06 GHz) in the 478-pin package based on the VRM 9.0 spec and 533 MHz. Built using the leading edge technology the Intel Pentium® 4 processors provide a significant performance over previous Pentium® III processors. Three DDR 200/266/333 SDRAM sockets allow for up to 2 GB memory capacity. Support for the Ultra DMA/100 protocol and its high-speed interface further ensures that data transfer speeds are improved, especially for long sequential transfers required by audio/visual applications.

The board features onboard audio and optional onboard LAN function; also, the optional serial ATA feature replaces the standard parallel ATA physical storage interface and allows future enhancements to the computing platform. It is completely software compatible with parallel ATA, requiring no modification to your operating system. The onboard serial ATA feature includes RAID function (level 0, 1) to provide you with a more efficient storage backup. For more detail, please read the help file in the 1st Utilities CD.

The 1stMainboard comes with a versatile range of I/O features such as 2 serial ports, 1 parallel port, 1 optional LAN, 3 optional IEEE 1394, 1 PS/2 mouse and keyboard connector, 6 USB ports, 1 media connector (front audio, Line-in, Line-out and Mic-in, optional game/MIDI port). In addition, the board is equipped with 2 dual channel enhanced PCI bus master IDE connectors. Ample expansion is available through 5 PCI and 1 AGP (VC19G+ allows DVO/AGP/DAC, VC19E+ supports AGP) to meet the requirement for enjoying the P4 CPU benefits in internet applications, video/3D graphics performance, and so forth.

Other key features are Remote On/Off, Auto Power Failure Recovery, integrated temperature monitoring and system fan control. Included also is 1st Utilities CD with enhanced drivers and a few bundled software solutions.

## Package Checklist

If you discover any item below was damaged or lost, please contact your vendor.

- The mainboard       This user manual
- One FDD cable       Software CD
- One ATA/100 cable    I/O shielding
- One A73 bracket with cable (optional)
- One serial ATA cable and one power cable (optional)
- One 1394 bracket with cable (optional)



**NOTE:** **Ist Utilities** CD that contains patch files, onboard video/audio chip drivers, related online help and other useful information can be found in your mainboard package.

*Please install it right after your Windows operating system installation is done.* Place your Ist Utility in the drive, an operating menu will appear in your monitor. Please select *Auto Installation*. It will automatically detect which software tools (patch files, drivers) that the mainboard needs. Press **OK** button to go through the whole installation procedure in a very straight forward and easy way. It also provides you with a custom way to select wanted patch files and software drivers that for onboard chips use. **The top menu of Ist Utilities lists all the functions that allowed by this board.**

## The VC19G+/VC19E+ Mainboard

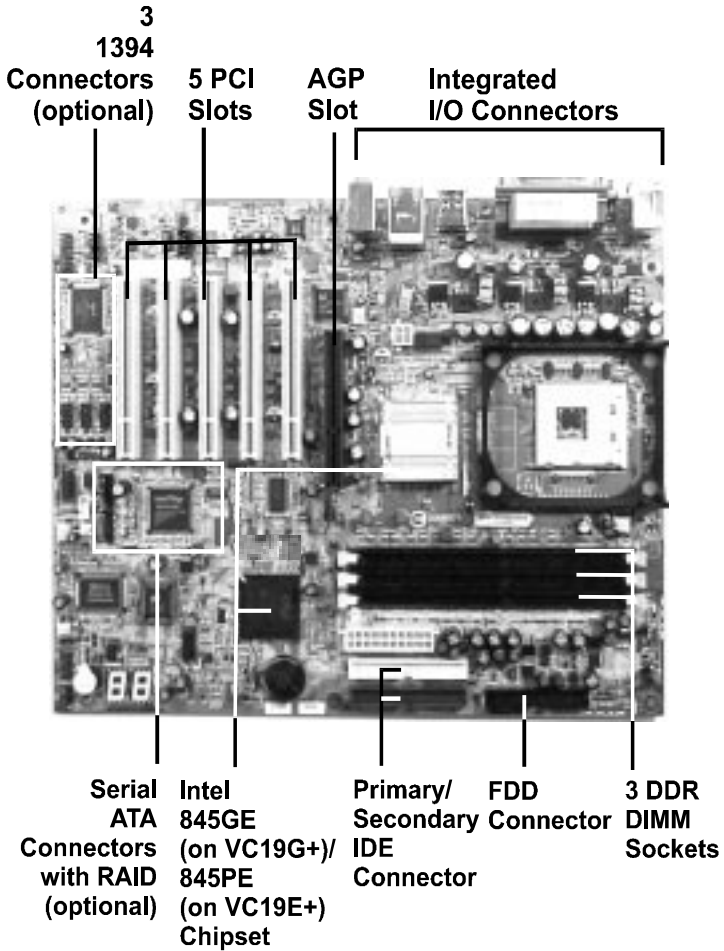

## Main Features

### ■ Easy Installation

BIOS with support for Plug and Play, auto detection of IDE hard drives, LS-120 drives, IDE ZIP drives, Windows 98SE, Windows ME, Windows NT, Windows 2000, Windows XP, and OS/2.

### ■ Leading Edge Chipset

Intel®845GE (VC19G+)/845PE (VC19E+) provides integrated DRAM controllers with new Dynamic Power Management Architecture (DPMA), concurrent PCI, AGP and USB. The built-in audio and video features of the Intel chipset provide better visual performance with the Dynamic Video Memory Technology (DVMT) properties.

### ■ Versatile Main Memory Support

Accepts up to 2 GB DDR SDRAM using three memory sockets for allowing that from 64, 128, 256, 512MB with support for lightening-fast DDR SDRAM (DDR 200/266/333 MHz).

### ■ Intel P4 Processors Support

1.4G to 2.5 GHz and up\* (FSB 400) / Celeron 1.7 -2.0GHz and up\* (FSB 400)  
2.0G to 3.06 GHz and up\* (FSB 533)  
(\*: not tested yet)

### ■ AGP and PCI Expansion Slots

One AGP Bus (VC19G+ supports DVO/AGP/DAC(VGA); VC19E+ supports AGP) expansion slot (only 1.5V 4X card allowed), and five PCI Bus expansion slots provided the room to install a full range of add-on cards.

### ■ Super Multi Input/Output (I/O) Support

Integrated Plug and Play multi-I/O chipset features two high-speed UART 16550 compatible serial ports, one parallel port, one optional game port, and one HDD connector.

### ■ Integrated Audio Subsystem

Embedded audio features in the ICH4 with an integrated PCI audio controller, DOS games compatible engine. The subsystem utilizes line-out, line-in, and MIC external jacks, one joystick port with MIDI interface.



■ Convenient Rear Panel USB Connection Support

Four USB 2.0 ports integrated in the rear I/O panel and one USB 2.0 pinheader for either front or rear panel connection allow convenient and high-speed Plug and Play connections to the growing number of USB compliant peripheral devices on the market.

■ Enhanced PCI Bus Master IDE Controller with Ultra DMA 33/66/100 Support

Integrated Enhanced PCI Bus Master IDE controller features two dual-channel connectors that up to four Enhanced IDE devices, including CD-ROM and Tape Backup Drives, as well as Hard Disk Drives supporting the new Ultra DMA 100 protocol. Standard PIO Mode 3, PIO Mode 4, DMA Mode 2, DMA Mode 4, UltraDMA-100 Mode 5 devices are also supported.

■ Onboard Accelerated Graphics Port (AGP)

The board is installed one 32-bit 1.5V AGP 4X bus with a dedicated 66MHz/133MHz path from the graphics card to the system memory. AGP enabled 3D graphics cards can directly access main memory across this fast path instead of using local memory.

■ 5.1 Channel Audio Support (optional)

The board owns an optional audio controller that gives magnificent 5.1 channel audio effect. It meets PC99® and supports digital audio interface.

■ IDE RAID Support (optional)

The optional SATA feature includes RAID function. It allows this board to back up huge amount data in an economic way. The RAID controller offers features that of level 0, 1 and supports the most popular operating systems, such as Windows 95/98SE/ME/NT 4.0/2000/XP and Linux.

■ LAN Support (optional)

Onboard optional LAN controller with one optional jack integrated with other rear panel I/O connectors provides users with a convenient connection with network environment.

- 1394 Support (optional)

One optional 1394 controller with three optional 2x5 pinheaders of 1394 ports (Intel spec.) for more efficient peripheral device connection and data transaction.

## FIC Unique Innovation for Users (NOVUS) - Enhanced Mainboard Features and System Support

- LogoGenie

A user friendly GUI supporting Windows 95/98SE (not Windows 2000/NT/ME/XP), LogoGenie allows you to customize, create or select a Logo which will be displayed when the system is booting.



**NOTE:**

Please read Page 3-7 for detail information.

- BIOS Guardian

BIOS Guardian effectively acts as a fire-wall against viruses that can attack the BIOS while the system is running and by default is enabled.

**WARNING:**

BIOS Guardian must be disabled before reflash BIOS.



**NOTE:**

Please read Page 3-7 for detail information.

- Easy Key

Instead of completing the multi-layered BIOS setup process these 3 Easy Key functions provide direct access to Sub-Menu when completing BIOS settings adjustments.

Easy-Keys are as follows:

**Ctrl + c:** To enter clock settings menu.

**Ctrl + p:** To load Performance Default settings and restart.

**Ctrl + f:** To load Fail-Safe Default settings and restart.

# Installation Procedures

The mainboard has several user-adjustable jumpers on the board that allow you to configure your system to suit your requirements. This chapter contains information on the various jumper settings on your mainboard.

To set up your computer, you must complete the following steps:

- Step 1 - **Set system jumpers**
- Step 2 - **Install memory modules**
- Step 3 - **Install the Central Processing Unit (CPU)**
- Step 4 - **Install expansion cards**
- Step 5 - **Connect ribbon cables, cabinet wires, and power supply**
- Step 6 - **Set up BIOS software**
- Step 7 - **Install supporting software tools**



**WARNING:** Excessive torque may damage the mainboard. When using an electric screwdriver on the mainboard, make sure that the torque is set to the allowable range of 5.0 ~ 8.0kg/cm.

Mainboard components contain very delicate Integrated Circuit (IC) chips. To prevent static electricity from harming any of the sensitive components, you should follow the following precautions whenever working on the computer:

1. Unplug the computer when working on the inside.
2. Hold components by the edges and try not to touch the IC chips, leads, or circuitry.
3. Wear an anti-static wrist strap which fits around the wrist.
4. Place components on a grounded anti-static pad or on the bag that came with the component whenever the components are separated from the system.

## Quick Reference (from Page 2-2 to 2-4)

### Mainboard Layout

Chapter 2  
Installation  
Procedures

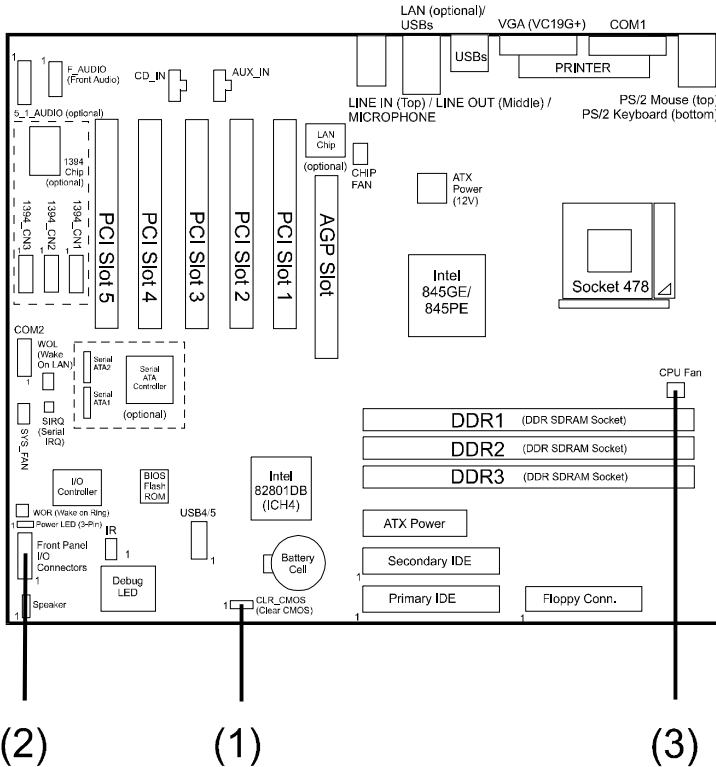

- \* When link to Line\_Out jack, please use a speaker that with amplifier.
- \* Connector SIRQ is for system integration use.

## 1). Clear CMOS

### CLR\_CMOS (Clear CMOS)



**Enable**  
(Clear CMOS)



**Disable**  
(Default)

## 2). Front Panel Block Cable Connection

### F\_PNL (Intel spec.)

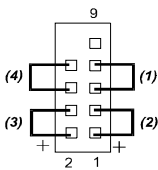

(4). Power Button      (1). Reset Button

(3). Dual Power LED  
(If use dual power LED,  
green: Pin2, yellow: Pin4;  
otherwise, Pin2 is positive,  
Pin4 is negative.)      (2). HDD LED

### IR (Intel spec.)

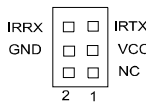

### PW\_LED (Single Color, Power LED 2 or 3 pins)



### SPK (Speaker)



### 3). CPU Fan Installation

This connector is linked to the CPU fan. When the system is in some power saving mode, the CPU fan will turn off; when it reverts back to full on mode, the fan will turn back on. Without sufficient air circulation, the CPU may overheat resulting in damage to both the CPU and the mainboard.

*Damage may occur to the mainboard and/or the CPU fan if these pins are used incorrectly. These are not jumpers, do not place jumper caps over these pins.*

### 1). Set System Jumpers



**NOTE:** Users are not encouraged to change the jumper settings not listed in this manual. Changing the jumper settings improperly may adversely affect system performance.

#### *Clear CMOS: CLR\_CMOS*

- (1) Turn off your computer
- (2) Place the jumper cap onto the pinpair 2-3 at least 6 seconds to clear CMOS
- (3) Place the jumper cap onto the pinpair 1-2 to Normal
- (4) Turn on your computer until CMOS checksum error appears
- (5) Hold down the **Delete** key when boots
- (6) Enter the BIOS Setup to re-enter user preferences, save it and exit.



**Enable**  
(Clear CMOS)



**Disable**  
(Default)

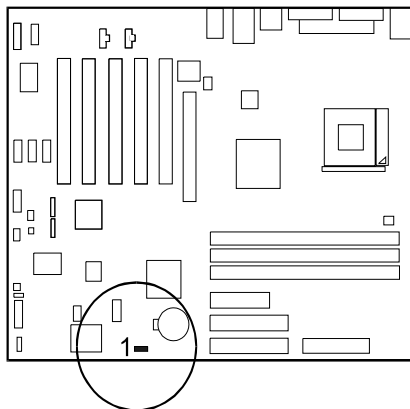

## 2). Install Memory Modules

1. Locate DDR DIMM sockets on the mainboard.
2. Install DDR DIMM straight down into the socket 1 using both hands, then socket 2, and so forth.
3. The clip on both ends of the socket will close up to hold the DDR DIMM in place when the DDR DIMM reaches the socket bottom.

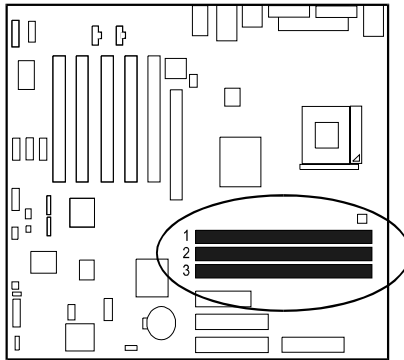

**NOTE:** Usually, the DIMM3 socket is reserved. It will be used only when users install two single-bank DIMM modules on DIMM2 and DIMM3 respectively.

In other words, only two types of DIMM installation are allowed:

(1).

Socket 1: either single- or double-bank DIMM on it.

Socket 2: double-bank DIMM on it.

Socket 3: left empty.

(2).

Socket 1: either single- or double-bank DIMM on it.

Socket 2: single-bank DIMM on it.

Socket 3: single-bank DIMM on it.

Press the clips with both hands to remove the DIMM.

### 3). Install the CPU

The mainboard has built-in Switching Voltage Regulator to support CPU Vcore autodetection. That is, It has the ability to detect and recognize the CPU voltage, clock, ratio and enables users to set up the CPU frequency from the BIOS Setup Screen. Users can adjust the frequency through *Frequency / Voltage Control* of the BIOS Setup Screen.

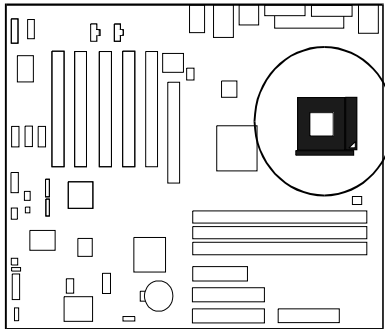

Chapter 2  
Installation  
Procedures

When you install the CPU on this mainboard, please use a power supply that designed and manufactured only for your CPUs use. Your CPU fansink combined with its retention module must be completely closed and firmly attached on the top of the processor.

To install the CPU, do the following:

1. Lift the lever on the side of the CPU socket.
2. Handle the chip by its edges and try not to touch any of the pins.
3. Place the CPU in the socket. Do not force the chip. The CPU should slide easily into the socket.
4. Swing the lever to the down position to lock the CPU in place.
5. Place the cooling fan with heatsink on top of the installed CPU.



**NOTE:** Users The CPU installing procedures should be:

1. Insert the CPU (with its fansink and retention module) on the socket.
2. Connect the 20-pin plug of the power supply
3. Connect the 4-pin plug of the power supply.

To remove the processor, please do it in reverse order.



## 4). Install Expansion Cards

This section describes how to connect an expansion card to one of your system expansion slots. Expansion cards are printed circuit boards that, when connected to the mainboard, increase the capabilities of your system. For example, expansion cards can provide video and sound capabilities. The mainboard features one AGP and five PCI bus expansion slots.

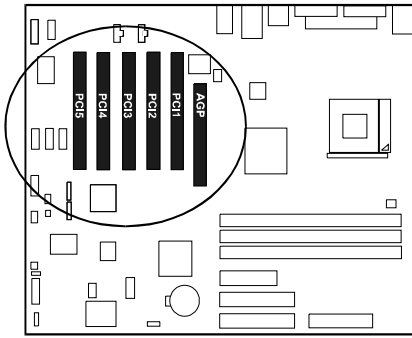

**CAUTION:** Make sure to unplug the power supply when adding or removing expansion cards or other system components. Failure to do so may cause severe damage to both the mainboard and expansion cards.

Always observe static electricity precautions.

Please read Handling Precautions at the start of this manual.

This VC19G+ mainboard supports 1.5V AGP 4X cards. VC19E+ supports 1.5V AGP 4X cards. Any other type cards may damage card and mainboard.

To install an expansion card, follow the steps below:

1. Remove the computer chassis cover and select an empty expansion slot.
2. Remove the corresponding slot cover from the computer chassis. Unscrew the mounting screw that secures the slot cover and pull the slot cover out from the computer chassis. Keep the slot cover mounting screw nearby.

3. Holding the edge of the peripheral card, carefully align the edge connector with the expansion slot.
4. Push the card firmly into the slot. Push down on one end of the expansion card, then the other. Use this rocking motion until the add-on card is firmly seated inside the expansion slot.
5. Secure the board with the mounting screw removed in Step 2. Make sure that the card has been placed evenly and completely into the expansion slot.
6. Replace the computer system cover.
7. Setup the BIOS if necessary.
8. Install the necessary software drivers for the expansion card.

## 5). Connect Devices

### *Floppy Diskette Drive Connector*

This connector provides the connection with your floppy disk drive. The red stripe of the ribbon cable must be the same side with the Pin 1.

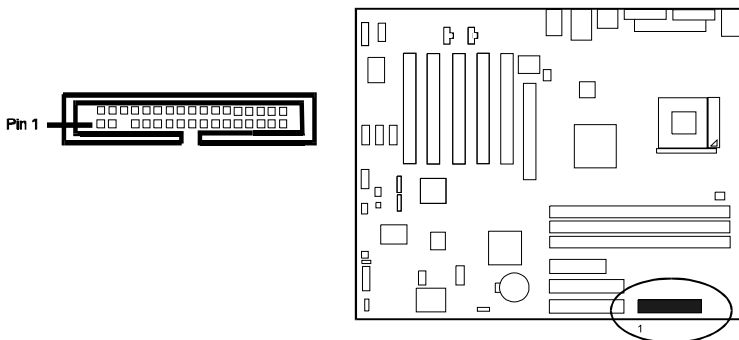

### IDE Device Connectors

The two connectors, PRIMARY and SECONDARY, are used for your IDE hard disk drives, CD drives, LS-120 drives, or IDE ZIP drives. The red stripe of the ribbon cable must be the same side with the Pin 1.

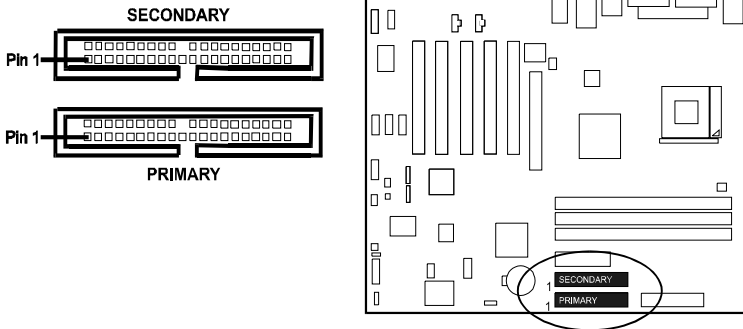

**Chapter 2  
Installation  
Procedures**

### Fan Connectors

The two connectors, CPU\_FAN, SYS\_FAN are linked to the CPU fan, case fan, respectively. CHIP\_FAN can be used with North Bridge chip fan.

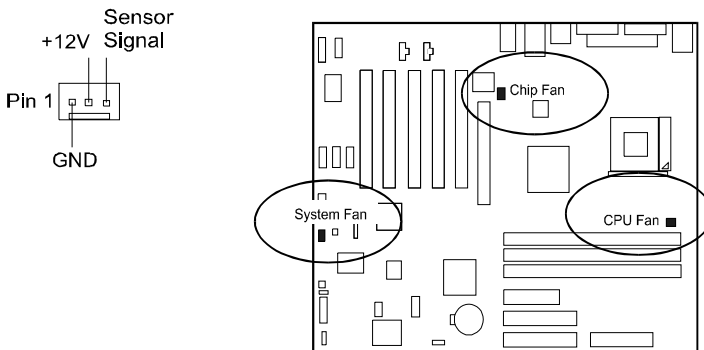

### Wake-On-Lan Connector

This 3-pin connector allows the remote servers to manage the system that installed this mainboard via your network adapter which also supports WOL. When you install such a LAN card, please read its installation guide for more information.

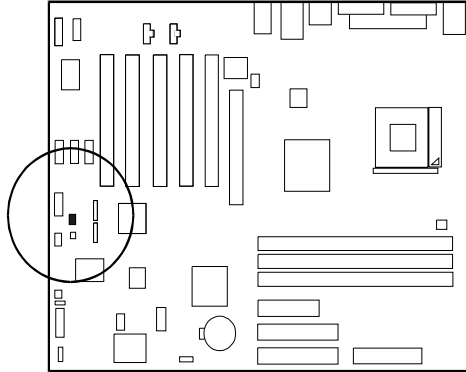
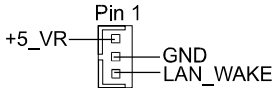

### Wake-On-Ring Connector

The 2-pin connector allows you to link with your modem card which outputs a WOR signal; the system can be turned on from the power-off status by a remote phone call via the modem card.

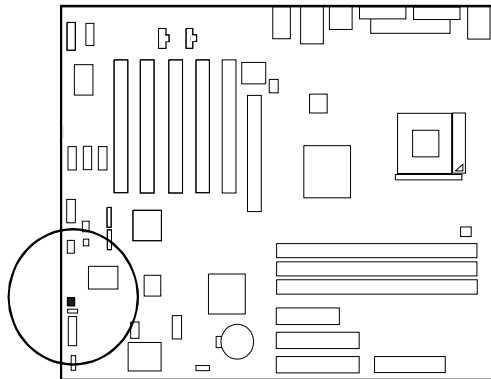
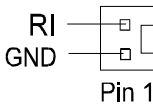

### Power Connectors

The 20-pin male block connector is connected to the ATX power supply. The 4-pin male block connector is for the ATX\_12V power use. All two connectors are linked with your ATX power supply. The plug from the power supply will only insert in one orientation because of the different hole sizes. Find the proper orientation and push down firmly making sure that the pins are aligned.

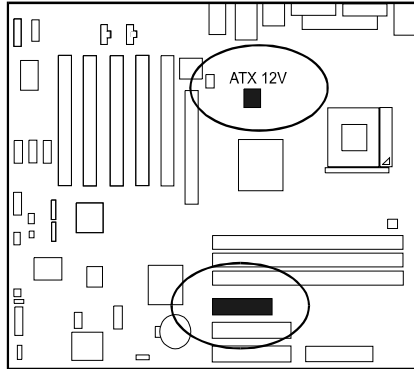
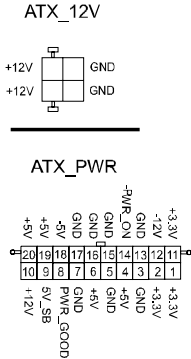

**Chapter 2  
Installation  
Procedures**

### CD Audio-In Connectors

The connectors, CD\_IN and AUX\_IN, are for CD-ROM drive audio analog input use.

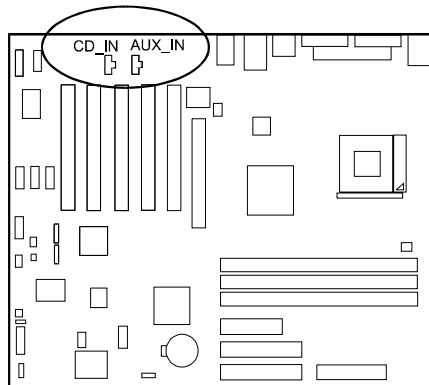

## Front Panel Block and IR Connector

This block connector includes the connectors for linking with Power LED (2 pins and 3 pins), HDD LED, power/sleep button, power/sleep LED, reset button on the front panel of the system case. Please identify polarities of plug wires for the case speaker and LEDs. Please ask vendor about this information when you buy them and install the system by yourself. The plug wires polarities of these buttons will not affect the function.

**F\_PNL**  
(Intel spec.)

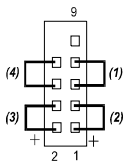

**IR**  
(Intel spec.)

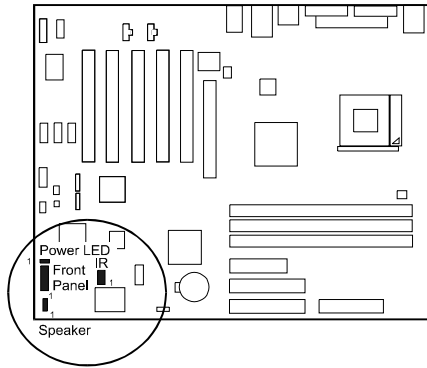
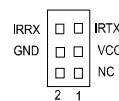

**PW\_LED**  
(Single Color, Power LED  
2 or 3 pins)



**SPK**  
(Speaker)



(1) **Reset Switch** is connected to the reset button. Push this switch to reboot the system instead of turning the power button off and on.

(2) **HDD LED** is connected to the IDE device indicator. This LED will blink when the hard disk drives are activated.

(3) **Power /Sleep LED** (2-Pin/3-Pin)

Please refer to the tables below for the representations of LED states.

**Single-Color (2, 3 Pins)**

LED	Meaning	State
Off	Off	S4/S5
On	Full On	S0
Flash	Sleep	S1/S3

**Dual-Color**

LED	Meaning	State
Off	Off	S4/S5
Green	Full On	S0
Yellow	Sleep	S1/S3

(4) **Power Button** is connected with power button. Push this switch allows the system to be turned on and off rather than using the power supply button.

**IR** is a pinheader that is used for linking with your ID device to allow transmission of data to another system that also supports the IR feature.

**Speaker** is a pinheader for connecting to speaker.

### *SIRQ Connector*

The 2-pin connector provides with a connection for some add-on cards that require a serial IRQ linkage to the mainboard for the system operation use.

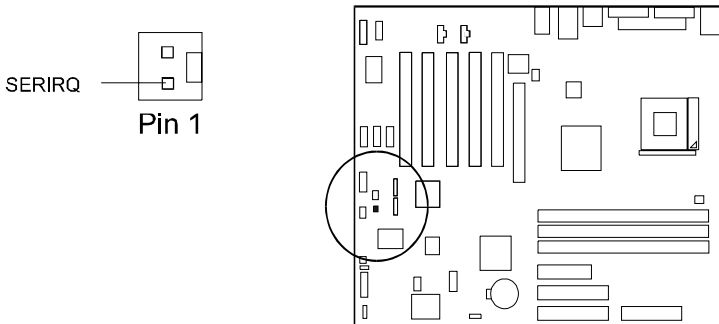

### IEEE 1394 Connectors (optional)

The board has three pinheaders of IEEE 1394 port to connect with their compatible peripheral devices for higher system performance via an optional cable.

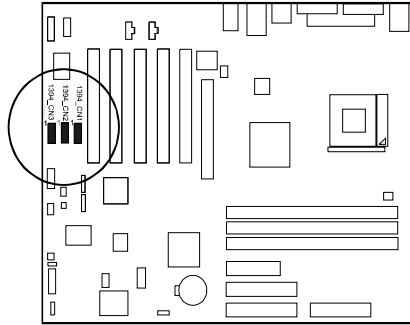
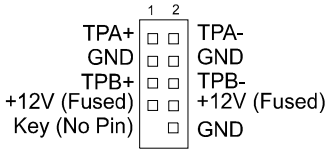

Chapter 2  
Installation  
Procedures

### Serial ATA Connectors (optional)

The 2 optional connectors with optional cable provide you with the connection two serial ATA devices that support Serial ATA specification. Serial ATA allows all ATA and ATAPI devices, including high capacity removable devices, optical devices, tape storage devices, and zip devices. The connectors also allows two RAID hard disks for level 0 and 1 RAID functions.

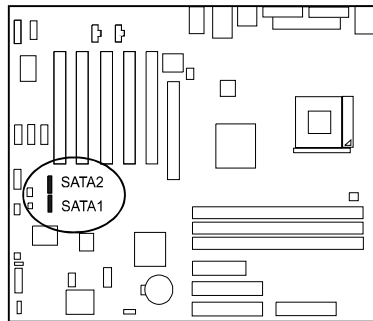



### Serial Port Connectors

COM1 (9-pin D-sub male connector with teal color) and COM2 (2x5 pinheader) allow you to connect with your devices that use serial ports, such as a serial mouse or an external modem.

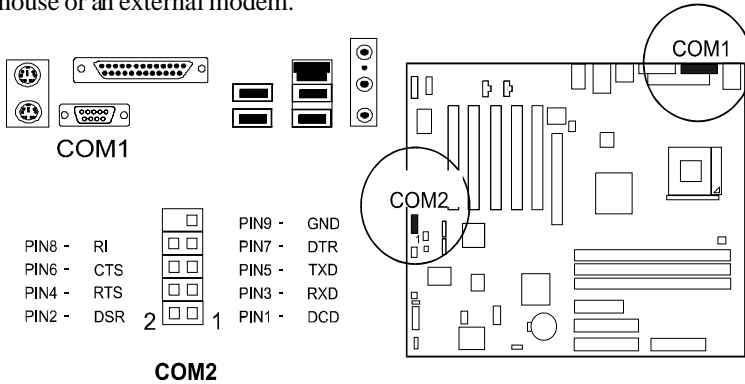

### PS/2 Keyboard and Mouse Connector

These two 6-pin female (PS/2 keyboard is purple color and PS/2 mouse is green color) connectors are used for your PS/2 keyboard and PS/2 mouse.

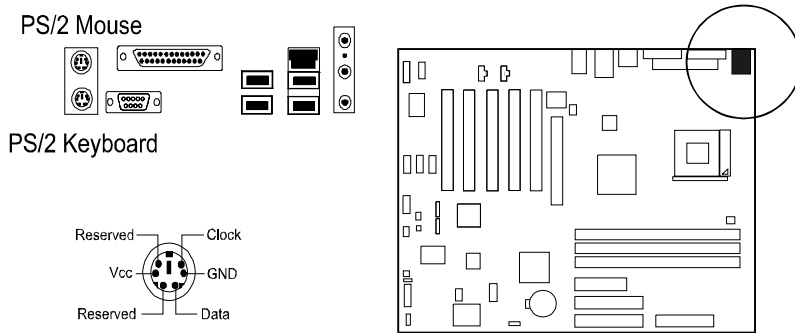

### Universal Serial Bus Connectors

These four USB black jacks integrated on the edge of the board are used for linking with USB 2.0 peripheral devices. This board also provides one USB pinheader (two extra USB 2.0 ports) for either linking with some system cases. Please note that your operating system must support USB features.

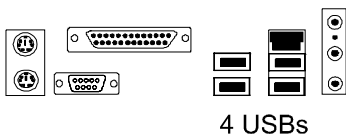

The figure below is the pin assignment of the USB4/5 pinheader.

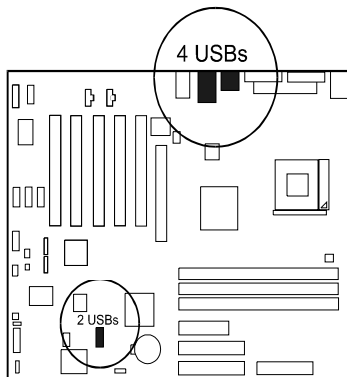
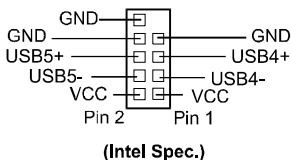

Chapter 2  
Installation  
Procedures

### LAN Connector (optional)

The optional LAN jack is used for the LAN cable plug.

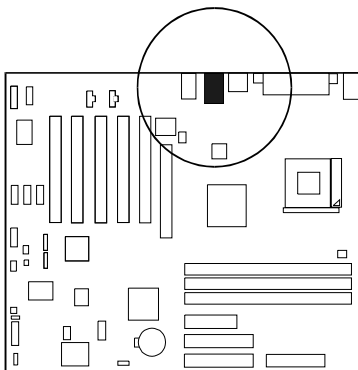
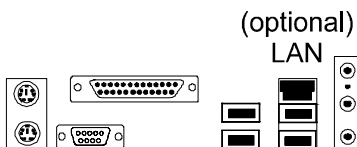

### Audio I/O Jacks

LINE\_OUT (lime) can be connected to headphones or preferably powered speakers. LINE\_IN (light blue) allows tape players or other audio sources to be recorded by your computer or played through the LINE\_OUT. MIC\_IN (pink) allows microphones to be connected for voice input. The mainboard also has a front panel audio connector (Intel spec.), F\_AUDIO, with an optional cable.



**NOTE:** If you do not use F\_AUDIO, please keep the pinpair 5-6, 9-10 short as default; also, when the front headphone is plugged in, the rear audio output will be disabled.

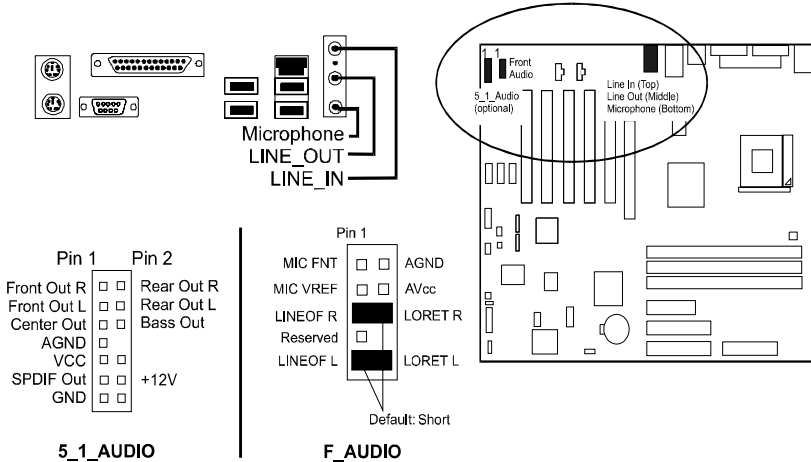

**NOTE:** If your mainboard has 5.1-channel audio option, use LINE\_IN, LINE\_OUT, MICROPHONE jacks can be the 5.1-channel audio output.

The mainboard has two types of audio specifications: 5.1-channel and general 2-channel. The board that with 5.1 audio feature is used with an optional A73 audio bracket. When use the bracket, plug in the LINE\_OUT jack for the front speaker audio output

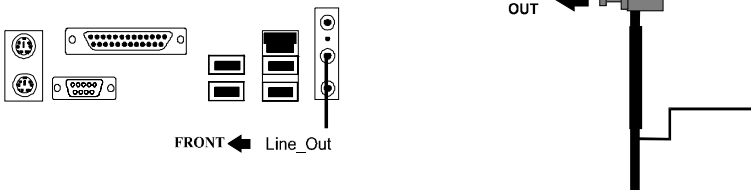

### Printer Connector

This 25-pin D-Sub female burgundy-colored connector is attached to your printer.

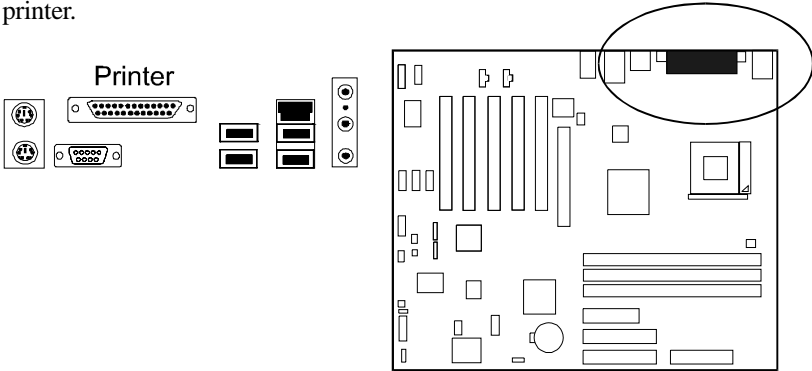

Chapter 2  
Installation  
Procedures

### Video Graphics Accelerator Connector (VC19G+ only)

This 15-pin female D-sub blue connector is connected to your display monitor.

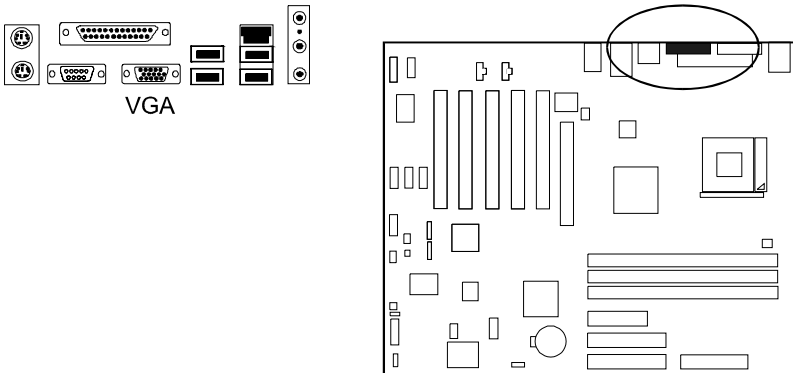

# BIOS Setup

The mainboard comes with the chip that Award BIOS that contains the ROM Setup information of your system. (This chip serves as an interface between the processor and the rest of the mainboard components.) This section explains the information contained in the Setup program and tells you how to modify the settings according to your system configuration.

## CMOS Setup Utility

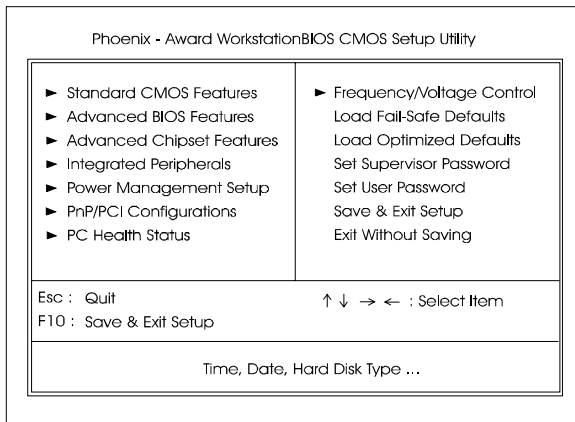

The Setup utility program allows updates to the mainboard configuration settings. The BIOS setup values will be saved in the CMOS. It is executed when the user changes system configuration; user changes system backup battery; or the system detects a configuration error and asks the user to run the Setup program. Use the arrow keys to select and press **Enter** to run the selected program.

## Standard CMOS Setup

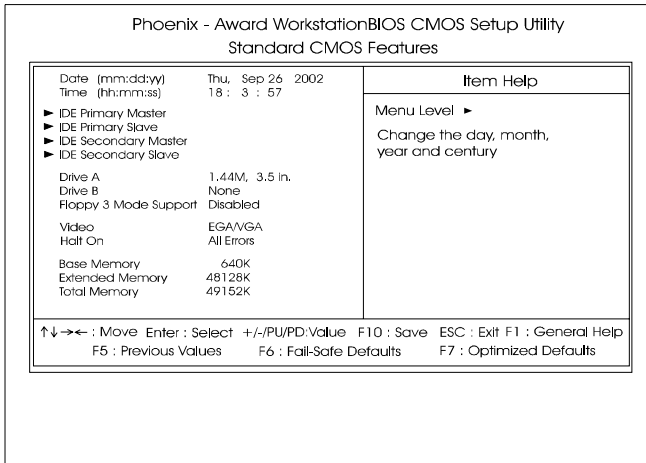

The Standard CMOS Setup screen is displayed above. Each item may have one or more option settings. The system BIOS automatically detects memory size, thus no changes are necessary. Use the arrow keys to highlight the item and then use **PgUp** or **PgDn** keys to select the value you want in each item.

### Date

To set the date, highlight the *Date* field and then press **Page Up/Page Down** or +/- keys to set the current date. Follow the month, day and year format.

### Time

To set the time, highlight the *Time* field and then press **Page Up/Page Down** or +/- keys to set the current time. Follow the hour, minute, and second format.

## Hard Disks

This field records the specifications for all non-SCSI hard drives installed in the system. The onboard PCI IDE connectors provide Primary and Secondary channels for connecting up to four IDE hard disks or other IDE devices. Each channel can support up to two hard disks, the first of which is the *Master* and the second is the *Slave*.

### Hard Disk Configurations

<b>Capacity:</b>	The hard disk size. The unit is Bytes.
<b>Cylinder:</b>	The cylinder number of the hard disk.
<b>Head:</b>	The read/write head number of hard disk.
<b>Precomp:</b>	The cylinder number at which the disk drive changes the write current.
<b>Landing Zone:</b>	The cylinder number that the disk drive heads (read/write) are seated when the disk drive is parked.
<b>Sector:</b>	The sector number of each track defined on the hard disk.

## Drive A / Drive B

This field records the types of floppy drives installed in the system. To enter the configuration value for a particular drive, highlight its corresponding field and then select the drive type using the **left-** or **right-arrow** key.

## Floppy 3 Mode Support

This is a Japanese standard floppy type drive. The standard stores 1.2MB in a 3.5 inch diskette.

## Video

Set this field to the type of video display card installed in the system.

## Halt On

This field determines which types of errors will cause the system to halt.

## Advanced BIOS Features

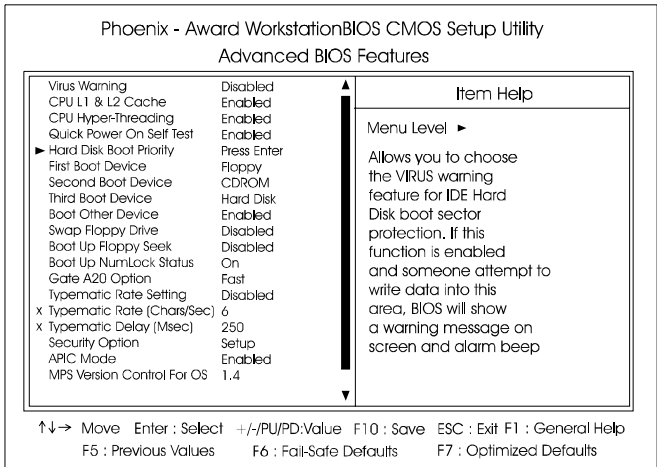

### Virus Warning

This feature starts the virus scan tool to detect if boot virus in boot sector of the first hard disk drive when booting up.

The options are: Enabled, Disabled.

### CPU L1 & L2 Cache

When enabled, improves the system performance. Disable this item when testing or trouble-shooting. The options are: Enabled, Disabled.

### CPU Hyper-Threading

Hyper-Threading Technology is a term of simultaneous Multi-threading Technology (SMT). Where multiple threads of software applications can be run simultaneously on one CPU. The options are: Enabled, Disabled.

### Quick Power On Self Test

When enabled, allows the BIOS to bypass the extensive memory test.

The options are: Enabled, Disabled.

### Hard Disk Boot Priority

This feature will auto detect all hard disks of bootable device on the system. It also allows users to select hard disk device booting priority.



### First/Second/Third Boot Device

This feature allows user to select the boot device priority. The options are: Floppy, LS120, Hard Disk, CDROM, ZIP100, USB-FDD, USB-ZIP, USB-CDROM, USB-HDD, LAN, Disabled.

### Boot Other Device

This feature allows user to select the boot device priority. The options are: Enabled, Disabled.

### Swap Floppy Drive

Allows you to switch the order in which the operating system accesses the floppy drives during boot up. The options are: Enabled, Disabled.

### Boot Up Floppy Seek

When enabled, assigns the BIOS to perform floppy diskette drive tests by issuing the time-consuming seek commands. The options are: Enabled, Disabled.

### Boot Up Numlock Status

When set to On, allows the BIOS to automatically enable the Num Lock Function when the system boots up. The options are: On, Off.

### Gate A20 Option

When set at Fast, allows a faster access response under Protected mode. The options are: Fast, Normal.

### Typematic Rate Setting

The term typematic means that when a keyboard key is held down, the character is repeatedly entered until the key is released. The options are: Disabled, Enabled.

### Typematic Rate (Chars/Sec)

This feature is available only if the above item, Typematic Rate Setting, is set at Enabled. Sets the rate of a character repeat when the key is held down. The options are: 6, 8, 10, 12, 15, 20, 24, 30.

### Typematic Delay (Msec)

This feature is available only if the item, Typematic Rate Setting, is set at Enabled. Sets the delay time before a character is repeated.

The options are: 250, 500, 750, 1000 millisecond.

### Security Option

Allows to set the security level of the system. The options: Setup, System.

### APIC Mode

Allows you to decide if the system enters the APIC (Advanced Programmable Interrupt Controller) mode or not for more IRQs can be released.

The options are: Enabled, Disabled.

### MPS Version Control For OS

When two CPUs onboard (not this board) this feature allows you to select MPS (Multi-Processor Spec.) version control for OS when logo test executes. The options are: 1.1, 1.4.

### OS Select For DRAM > 64MB

If your operating system (OS) is OS/2, select the option OS2. Otherwise, stay with the default setting Non-OS2. The options are: Non-OS2, OS2.

### HDD S.M.A.R.T. Capability

S.M.A.R.T. stands for Self-Monitoring and Analysis Reporting Technology which allows your hard disk drive to report any read/write errors and issues a warning with LDCM installed. The options: Disabled, Enabled.

### Report No FDD For WIN 95

When the field under the Standard CMOS Setup Menu for Drive A and/or Drive B is set at None, users must set this field is set at Yes for it to function properly. Otherwise, set at No, even if field for Drive A and/or Drive B is set at None, system will still detect and recognize of a floppy drive(s).

The options are: Yes, No.

### BIOS Guardian

It allows the system to prevent computer viruses. Users will need to disable it to update BIOS. The options are: Enabled, Disabled.

**NOTE:**

Please disable this BIOS feature before you start to reflash BIOS.

***BIOS Guardian and Reflash BIOS***

BIOS Guardian by default is enabled, thus effectively acts as a fire-wall against viruses that can attack the BIOS while the system is running. It must be disabled before reflash BIOS.

The steps below show you how to off and on BIOS Guardian when reflash BIOS:

1. Press **Del** key while booting. Go to *CMOS Setup Utility* menu.
2. Go to *Advanced BIOS Features* submenu.
3. Set the feature *BIOS Guardian* at Disabled.
4. Save the setting and exit. The system restarts.
5. POST screen holds. A message about BIOS Guardian shows.
6. Press Space bar.
7. Reflash BIOS. Restart the system after complete it.
8. POST screen holds. A message about BIOS Guardian shows.
9. Press **G** key. The feature BIOS Guardian will be enabled again.

**Full Screen LOGO Show**

It decides whether or not the full screen logo is shown during system booting up. The options are: Enabled, Disabled.

**NOTE:**

1. LogoGenie supports Award BIOS only.
2. If you create a Logo file (.bmp) by LogoGenie, the file size must be 640 x 464 x 256 colors.

To enable this utility, please proceed as follows:

1. Insert software CD. Select LogoGenie from the Menu and follow the installation instructions.
2. After LogoGenie has been installed, go to Windows Start Box. In Programs Menu, select LogoGenie, then select LogoGenie.
3. Press F1 to read Help file to understand how to use this software if it is new to you.

## Advanced Chipset Features

### (VC19G+ Mainboard)

Phoenix - Award WorkstationBIOS CMOS Setup Utility  
Advanced Chipset Features

		Item Help
DRAM Timing Selectable	By SPD	
CAS Latency Time	2	
Active to Precharge Delay	7	
DRAM RAS# to CAS# Delay	3	
DRAM RAS# Precharge	3	
Memory Frequency For	Auto	
System BIOS Cacheable	Enabled	
Video BIOS Cacheable	Disabled	
Delayed Transaction	Enabled	
Delay Prior to Thermal	16 Min	
AGP Aperture Size (MB)	64	
** On-Chip VGA Setting **		
On-Chip VGA	Enabled	
On-Chip Frame Buffer Size	8MB	
Boot Display	Auto	

↑↓→← Move    Enter : Select    +/-/PU/PD:Value    F10 : Save    ESC : Exit    F1 : General Help  
 F5 : Previous Values    F6 : Fail-Safe Defaults    F7 : Optimized Defaults

### (VC19E+ Mainboard)

Phoenix - Award WorkstationBIOS CMOS Setup Utility  
Advanced Chipset Features

		Item Help
DRAM Timing Selectable	By SPD	
CAS Latency Time	2	
Active to Precharge Delay	7	
DRAM RAS# to CAS# Delay	3	
DRAM RAS# Precharge	3	
Memory Frequency For	Auto	
System BIOS Cacheable	Enabled	
Video BIOS Cacheable	Disabled	
Delayed Transaction	Enabled	
Delay Prior to Thermal	16 Min	
AGP Aperture Size (MB)	64	

↑↓→← Move    Enter : Select    +/-/PU/PD:Value    F10 : Save    ESC : Exit    F1 : General Help  
 F5 : Previous Values    F6 : Fail-Safe Defaults    F7 : Optimized Defaults

### DRAM Timing Selectable

This feature allows user to select the way to set DRAM timing.  
The options are: Manual, By SPD.

### CAS Latency Time

This feature allows user to select the CAS latency time, when any SDRAM DIMM installed. The options are: 1.5, 2, 2.5, 3.

### Active to Precharge Delay

This feature allows user to set Active to Precharge Delay, if any SDRAM installed.

The options are: 7, 6, 5.

### DRAM RAS# to CAS# Delay

The feature allows user to set the delay time that from the DRAM RAS# active to CAS#. The options are: 3, 2.

### DRAM RAS# Precharge

The feature allows user to set the DRAM RAS# Precharge Time.

The options are: 3, 2.

### Memory Frequency For

This feature allows users to set the memory frequency.

The options are: PC100, PC133, Auto.

### System BIOS Cacheable

Setting at Enabled will allow the caching of the BIOS ROM F0000H-FFFFFH, resulting in better system performance. It may cause system error when some program try to access the memory area.

The options are: Disabled, Enabled.

### Video BIOS Cacheable

Setting at Enabled will allow the caching of the video BIOS ROM at C0000H-C7FFFH, resulting in better video performance. It may cause system error when some program try to access the memory area.

The options are: Disabled, Enabled.

### Delayed Transaction

Setting at Enabled will abort the current PCI master cycle and to accept the new PCI master request, it reaccepts the original PCI master and returns the PCI data phase to the original PCI master. It will enhance the system performance. The options are: Disabled, Enabled.

### Delay Prior to Thermal

It allows user to select the Delay Prior to Thermal.  
The options are: 4 Min, 8 Min, 16 Min, 32 Min.

### AGP Graphics Aperture Size (MB)

It allows user to select the main memory frame size of AGP use.  
The options are: 4, 8, 16, 32, 64, 128, 256.

## for VC19G+ only

### On-Chip VGA

It allows user to disable the onchip video function.  
The options are: Enabled, Disabled.

### On-Chip Frame Buffer Size

It allows user to select the main memory frame size of AGP use.  
The options are: 1MB, 8MB.

### Boot Display

This feature allows you to select the display type while booting.  
The options are: Auto, CRT, TV, EFP.

## Integrated Peripherals

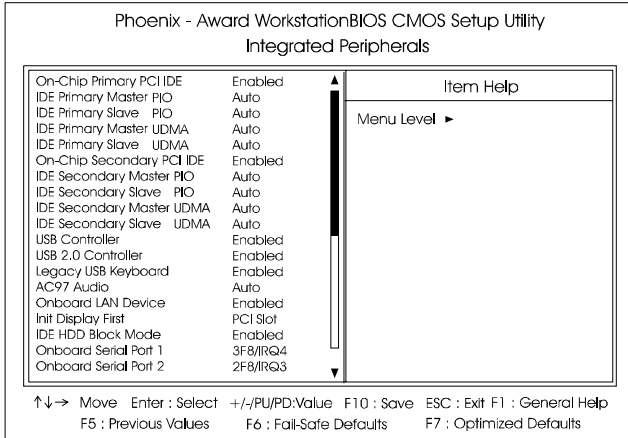

### On-Chip Primary PCI IDE

When enabled, it allows you to use the onboard primary PCI IDE.  
The options are: Enabled, Disabled.

### IDE Primary Master PIO

Allows an automatic or a manual configuration of the PCI primary IDE hard drive (master) mode. The options are: Auto, Mode 0, Mode 1, Mode 2, Mode 3, Mode 4.

### IDE Primary Slave PIO

Allows an automatic or a manual configuration of the PCI primary IDE hard drive (slave) mode. The options are: Auto, Mode 0, Mode 1, Mode 2, Mode 3, Mode 4.

### IDE Primary Master UDMA

Allows an automatic configuration of the PCI primary IDE hard drive (master) mode if Ultra DMA is supported both on the motherboard and the hard disk. The options are: Auto, Disabled.

### IDE Primary Slave UDMA

Allows an automatic configuration of the PCI primary IDE hard drive (slave) mode if Ultra DMA is supported both on the motherboard and the hard disk. The options are: Auto, Disabled.

### On-Chip Secondary PCI IDE

When enabled, it allows you to use the onboard secondary PCI IDE. The options are: Enabled, Disabled.

### IDE Secondary Master PIO

Allows an automatic or a manual configuration of the PCI secondary IDE hard drive (master) mode. The options are: Auto, Mode 0, Mode 1, Mode 2, Mode 3, Mode 4.

### IDE Secondary Master UDMA

Allows an automatic configuration of the PCI secondary IDE hard drive (master) mode if Ultra DMA is supported both on the motherboard and the hard disk. The options are: Auto, Disabled.

### IDE Secondary Slave UDMA

Allows an automatic configuration of the PCI secondary IDE hard drive (slave) mode if Ultra DMA is supported both on the motherboard and the hard disk. The options are: Auto, Disabled.

### USB Controller

Disable this option if you are not using the onboard USB feature. The options are: Disabled, Enabled.

### USB 2.0 Controller

Enable this item to support USB 2.0 devices. The options are: Disabled, Enabled.

### Legacy USB Keyboard

When a USB keyboard is installed, please set at Enabled. The options are: Disabled, Enabled.

### AC97 Audio

This feature auto detects if you use a card that with a CODEC to enable or disable the AC97 audio function. The options are: Auto, Disabled.



---

### Onboard Lan Device

This feature allows users to enable or disable the onboard Lan device. The options are: Enabled, Disabled.

### Init Display First

When you install an AGP VGA card and a PCI VGA card on the board, this feature allows you to select the first initiation of the monitor display from which card. The options are: PCI Slot, AGP.

### IDE HDD Block Mode

When enabled, the system executes read/write requests to hard disk in block mode. The options are: Enabled, Disabled.

### Onboard Serial Port 1/2

If the serial port 1/2 uses the onboard I/O controller, you can modify your serial port parameters. If an I/O card needs to be installed, COM3 and COM4 may be needed. The options are: Disabled, 3F8/IRQ4, 2F8/IRQ3, 3E8/IRQ4, 2E8/IRQ3.

### UART Mode Select

Allows you to select the IR modes if the serial port 2 is used as an IR port. Set at Standard, if you use COM2 as the serial port as the serial port, instead as an IR port. The options are: Normal, IrDA, ASKIR.

### RxD, TxDActive

This feature is available only if the item, UART 2 Mode, is set at ASKIR or HPSIR. The feature allows you to select the active signals of the reception end and the transmission end. This is for technician use only. The options are: Hi, Lo; Hi, Hi; Lo, Hi; Lo, Lo.

### IR Transmission Delay

When Enabled, the transmission delays 4 characters-time (40 bit-time) if SIR is changed from RX mode to TX mode. When Disabled, no transmission delay if SIR is changed from RX mode to TX mode. The options are: Enabled, Disabled.

### IDE Secondary Slave PIO

Allows an automatic or a manual configuration of the PCI secondary IDE hard drive (slave) mode. The options are: Auto, Mode 0, Mode 1, Mode 2, Mode 3, Mode 4.

### UR2 Duplex Mode

Allows you to select the IR modes.  
The options are: Full, Half.

### Use IR Pins

Allows you to select IR pin mode.  
The options are: Rx2D2, Tx2D2; IR-Rx2Tx2.

### Onboard Parallel Port

Allows you to select from a given set of parameters if the parallel port uses the onboard I/O controller.  
The options are: Disabled, 378/IRQ7, 278/IRQ5, 3BC/IRQ7.

### Parallel Port Mode

Allows you to connect with an advanced printer via the port mode it supports. The options are: SPP, EPP1.9+SPP, ECP, EPP1.9+ECP, EPP1.7+SPP, EPP1.7+ECP.

### EPP Mode Select

This feature allows you to select the EPP type version.  
The options are: EPP1.7, EPP1.9.

### ECP Mode Use DMA

This feature allows you to select Direct Memory Access (DMA) channel.  
The options are: 1, 3.

### PWRON After PWR-Fail

When the system is shut down owing to the power failure, the system will not be back to power on by itself. This feature allows you to set the system back to which power status of the system when the system power is resumed. The options are Former-Sts, On, or Off.

## Power Management Setup

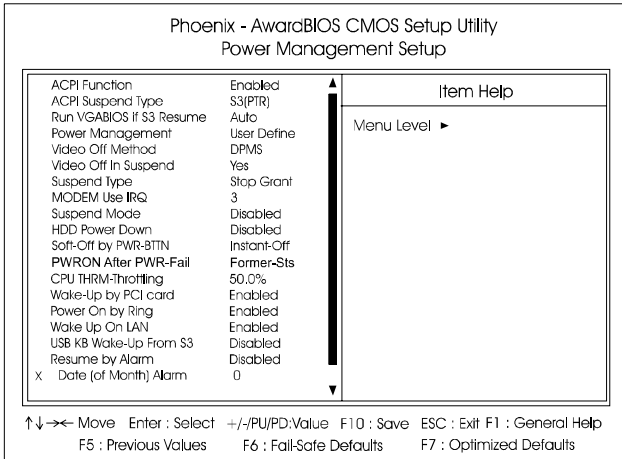

### ACPI Function

This item allows you to disable the ACPI function.  
The options are: Enabled, Disabled.

### ACPI Suspend Type

This item allows you to select suspend mode when the system in ACPI mode. The options are: S1 (POS), S3 (PTR), S1&S3.

### Run VGABIOS if S3 Resume

This feature allows you to decide the way if VGA BIOS should be called when the system resumes from S3 state if the above feature is set at S3 (PTR) or S1&S3. The options are Yes, No.

### Power Management

This item allows you to adjust the power management features.  
Select User Define for configuring your own power management features. Min Saving initiates all predefined timers in their minimum values. Max Saving, on the other hand, initiates maximum values.  
The options are: User Define, Min Saving, Max Saving.

### Video Off Method

The option *Blank Screen* allows the BIOS to blank off screen display by turning off the red-green-blue signals. The option *V/H SYNC+Blank* allows the BIOS to blank off screen display by turning off the V-Sync and H-Sync signals sent from add-on VGA card. The option *DPMS* allows the BIOS to blank off screen display by your add-on VGA card which supports DPMS (Display Power Management Signaling function).

The options are: Blank Screen, V/H SYNC+Blank, DPMS.

### Video Off In Suspend

The option allows you to select VGA status when the system goes to suspend mode. The options are: No, Yes.

### Suspend Type

The option allows you to select the suspend type that supported by the chipset. The options are: Stop Grant, PwrOn Suspend.

### MODEM Use IRQ

This feature allows you to select the IRQ# to meet your modem IRQ#.

The options are: NA, 3, 4, 5, 7, 9, 10, 11.

### Suspend Mode

When disabled, the system will not enter Suspend mode. The specified time option defines the idle time the system takes before it enters Suspend mode. The options are: Disable, 1, 2, 4, 8, 10, 20, 30, 40 Min, 1 Hour.

### HDD Power Down

The option lets the BIOS turn the HDD motor off when system is in Suspend mode. Selecting 1 Min..15 Min allows you define the HDD idle time before the HDD enters the Power Saving Mode.

The options 1 Min..15 Min will not work concurrently. When HDD is in the Power Saving Mode, any access to the HDD will wake the HDD up.

The options are: Disabled, 1 Min..15 Min.

### CPU THRM-Throttling

When thermal override condition occur, this item allows users to determine the duty cycle of the throttling.

The options are: 87.5%, 75.0%, 62.5, 50.0%, 37.5%, 25.0%, 12.5%.

---

### Wake-Up by PCI card

When set at Enabled, any PCI-PM event awakes the system from a PCI-PM controlled state. The options are Disabled, Enabled.

### Power On by Ring

An incoming call via modem awakes the system from its soft-off mode. The options are Disabled, Enabled.

### Wake Up On LAN

When set at Enabled, an input signal comes from the other client/server on the LAN awakes the system from a soft off state if connected over LAN. The options are Disabled, Enabled.

### USB KB Wake-Up From S3

When set at Enabled, it allows USB keyboard to activate the system from ACPI S3 power saving mode. The options are Disabled, Enabled.

### Resume by Alarm

This feature allows you to set the when the system being turned on from the system power-off status. The options are: Enabled, Disabled.

### Date (of Month) Alarm

This feature allows you to set the day of the alarm starts when the RTC Alarm Resume From Soft Off is set to be Enabled. The options are: 0, 1..31.

### Time (hh:mm:ss) Alarm

If an ATX power supply is installed and when RTC Alarm Resume is Enabled, this feature allows you to set the time of the alarm starts when the RTC Alarm Resume From Soft Off is set to be Enabled.

The options are: hh (*hour*) - 0, 1, 2,..., 23; mm (*minute*) - 0, 1, 2,...,59; ss (*second*) - 0, 1, 2,...,59.

### Primary IDE 0

When the primary master HDD is working, the system timer will be reloaded and the system will not be into the suspend mode.

The options are: Disabled , Enabled.

### Primary IDE 1

When the primary slave HDD is working, the system timer will be reloaded and the system will not be into the suspend mode.

The options are: Disabled, Enabled.

### Secondary IDE 0

When the secondary master HDD is working, the system timer will be reloaded and the system will not be into the suspend mode.

The options are: Disabled, Enabled.

### Secondary IDE 1

When the secondary slave HDD is working, the system timer will be reloaded and the system will not be into the suspend mode.

The options are: Disabled, Enabled.

### FDD, COM, LPT Port

When FDD, COM, or LPT is working, the system timer will be reloaded and the system will not be into the suspend mode.

The options are: Disabled, Enabled.

### PCI PIRQ[A-D]#

When the PCI PIRQ[A-D]# has been alerted, the system timer will be reloaded and the system will not be into the suspend mode.

The options are: Disabled, Enabled.

## PnP/PCI Configurations

Phoenix - AwardBIOS CMOS Setup Utility		Item Help
PnP/PCI Configurations		
Reset Configuration Data	Disabled	
Resources Controlled By x IRQ Resources	Auto(ESCD) Press Enter	Menu Level ▶
PCI/VGA Palette Snoop	Disabled	Default is Disabled.
INT Pin 1 Assignment	Auto	Select Enabled to
INT Pin 2 Assignment	Auto	reset Extended System
INT Pin 3 Assignment	Auto	Configuration Data
INT Pin 4 Assignment	Auto	(ESCD) when you exit
INT Pin 5 Assignment	Auto	Setup if you have
INT Pin 6 Assignment	Auto	installed a new add-on
INT Pin 7 Assignment	Auto	and the system
INT Pin 8 Assignment	Auto	reconfiguration has
		caused that a serious
		conflict that the OS
		cannot boot.

↑↓ →← Move Enter : Select +/-/PU/PD:Value F10 : Save ESC : Exit F1 : General Help  
F5 : Previous Values F6 : Fail-Safe Defaults F7 : Optimized Defaults

### Reset Configuration Data

Enabling it to reset the system Extended System Configuration Data (ESCD) when you exit Setup if you have installed a new add-on card and the system reconfiguration has caused such a serious conflict that the operating system can not boot. The options are: Disabled, Enabled.

### Resources Controlled By

If set at Auto, the BIOS arranges all system resources. If there exists conflict, select Manual. The options are: Auto (ESCD), Manual.

If the manual options, after the feature **IRQ Resources** being pressed, of **IRQ- Assigned To** are: PCI Device, Reserved. When resources were controlled manually, assign each system interrupt a type, depending on each device type to use the interrupt.

### PCI/VGA Palette Snoop

Set this feature to be enabled if any ISA adapter card installed in the system requires the VGA palette snoop function.

The options are: Disabled, Enabled.

### INT Pin 1/2/3/4/5/6/7/8 Assignment

This feature allows you to assign the PCI IRQ numbers for PCI slots. Selecting the default, Auto, allows the PCI controller to automatically allocate the IRQ numbers. The options are: Auto, 3, 4, 5, 7, 9, 10, 11, 12, 14, 15.

## PC Health Status

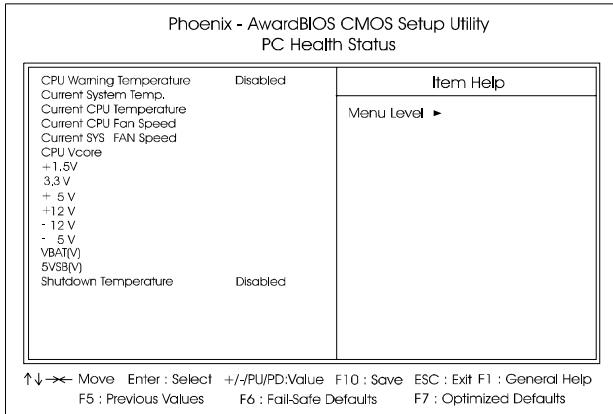

### CPU Warning Temperature

This feature allows you to set the temperature to slow down the CPU clock frequency. The option list presents all the temperatures that supported by the board and Disabled.

### Current System Temp. / Current CPU Temperature / Current CPU Fan Speed / Current SYS FAN Speed / Current Chip Fan Speed / CPU Vcore / +1.5V / 3.3V / +5V / +12V / -12V / -5V / VBAT(V) / 5VSB(V)

These items allow end users and technicians to monitor data provided by the BIOS on this mainboard. It is not user-configurable.

### Shutdown Temperature

This feature helps to shutdown the system when the system temperature is as high as the selected temperature to prevent from the overheat problem. The option list presents all the temperatures that supported by the board and Disabled.



## Frequency/Voltage Control

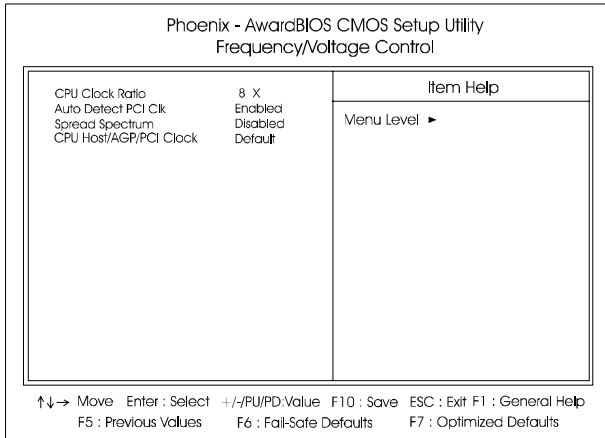

### CPU Clock Ratio

This feature allows you to enter the supported frequency multiplier for CPU host clock.

### Auto Detect PCI Clk

When enabled, BIOS will detect the PCI slot. If no any device in, BIOS will auto disable its clock. The options are: Enabled, Disabled.

### Spread Spectrum

This feature allows you to enable the spread Spectrum function. The options are: Enabled, Disabled.

### CPU Host/AGP/PCI Clock

This feature allows you to select the combinations of CPU, onboard AGP bus, and PCI clock frequency. The default setting, Default, will detect your CPU/AGP/PCI clock frequency automatically. If you set a inappropriate option which leads to a booting problem, keep pressing the Insert key until the display appears will solve it. The options lists all combinations that provided by the system BIOS.

## Load Fail-Safe Defaults

This submenu is selected to diagnose the problem after the computer boots, if the computer will not boot. These settings do not give optimal performance.

## Load Optimized Defaults

This submenu is selected for default settings which provide the best system performance.

## Supervisor/User Password

To enable the Supervisor/User passwords, select the item from the Standard CMOS Setup. You will be prompted to create your own password. Type your password up to eight characters and press Enter. You will be asked to confirm the password. Type the password again and press Enter. To disable password, press Enter twice when you are prompted to enter a password. A message appears, confirming the password is disabled.

Under the BIOS Feature Setup, if *Setup* is selected under the Security Option field and the Supervisor/User Password is enabled, you will be prompted password every time you try to enter the CMOS Setup Utility. If *System* is selected and the Supervisor/User Password is enabled, you will be requested to enter the Password every time when you reboot the system or enter the CMOS Setup utility.

## Save and Exit Setup

After you have made changes under Setup, press Esc to return to the main menu. Move cursor to Save and Exit Setup or press F10 and then press Y to change the CMOS Setup. If you did not change anything, press Esc again or move cursor to Exit Without Saving and press Y to retain the Setup settings. The following message will appear at the center of the screen to allow you to save data to CMOS and exit the setup utility: **SAVE to CMOS and EXIT (Y/N)?**

## Exit without Saving

If you select this feature, the following message will appear at the center of the screen to allow you to exit the setup utility without saving CMOS modifications: **Quit Without Saving (Y/N)?**