

FCC Information and Copyright

This equipment has been tested and found to comply with the limits of a Class B digital device, pursuant to Part 15 of the FCC Rules. These limits are designed to provide reasonable protection against harmful interference in a residential installation. This equipment generates, uses and can radiate radio frequency energy and, if not installed and used in accordance with the instructions, may cause harmful interference to radio communications. There is no guarantee that interference will not occur in a particular installation.

The vendor makes no representations or warranties with respect to the contents here of and specially disclaims any implied warranties of merchantability or fitness for any purpose. Further the vendor reserves the right to revise this publication and to make changes to the contents here of without obligation to notify any party beforehand. Duplication of this publication, in part or in whole, is not allowed without first obtaining the vendor's approval in writing.

The content of this user's manual is subject to be changed without notice and we will not be responsible for any mistakes found in this user's manual. All the brand and product names are trademarks of their respective companies.

Content

LAYOUT OF P4TS V VERSION 1.X.....	1
LAYOUT OF P4TS V VERSION 7.0.....	2
ENGLISH.....	3
P4TSV Features.....	3
Package contents.....	5
How to set up Jumper.....	5
CPU Installation.....	5
DDR DIMM Modules: DDRA1, DDRB1 (for v.7.0 only).....	6
DDR DIMM Modules: DDRA1-2, DDRB1-2.....	7
Installing DDR Module.....	7
Jumpers, Headers, Connectors & Slots.....	8
ESPAÑOL	15
Características del P4TSV.....	15
Contenido del Paquete.....	17
Cómo instalar un Puente.....	17
Instalación del CPU.....	17
Módulos DDR DIMM: DDRA1-2, DDRB1-2.....	18
Instalación del Módulo DDR.....	19
Puentes, Cabezales, Conectores y Ranuras.....	20
DEUTSCH.....	26
Spezifikationen von P4TSV.....	26
Verpackungsinhalt.....	28
Einstellung der Jumper.....	28
Installation der CPU.....	28
DDR DIMM Modules: DDRA1-2, DDRB1-2.....	29
Installation von DDR-Modul.....	30
Jumpers, Headers, Anschlüsse & Slots.....	31
FRANÇAIS	37
Caractéristiques de P4TSV.....	37
Contenu de l'Emballage.....	38
WARPSPEEDER.....	39
TROUBLE SHOOTING.....	49
SOLUCIÓN DE PROBLEMAS	50
PROBLEMLÖSUNG.....	51

Layout of P4TSV Version 1.x

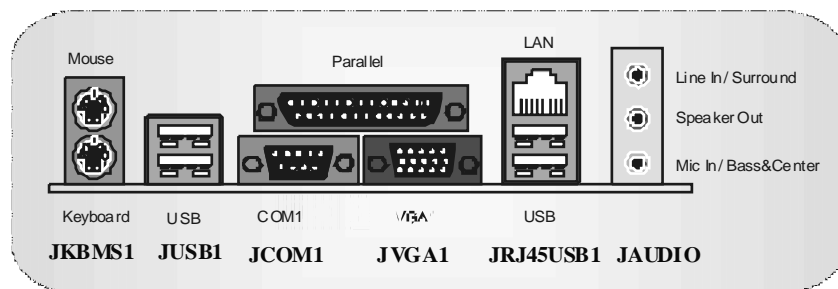
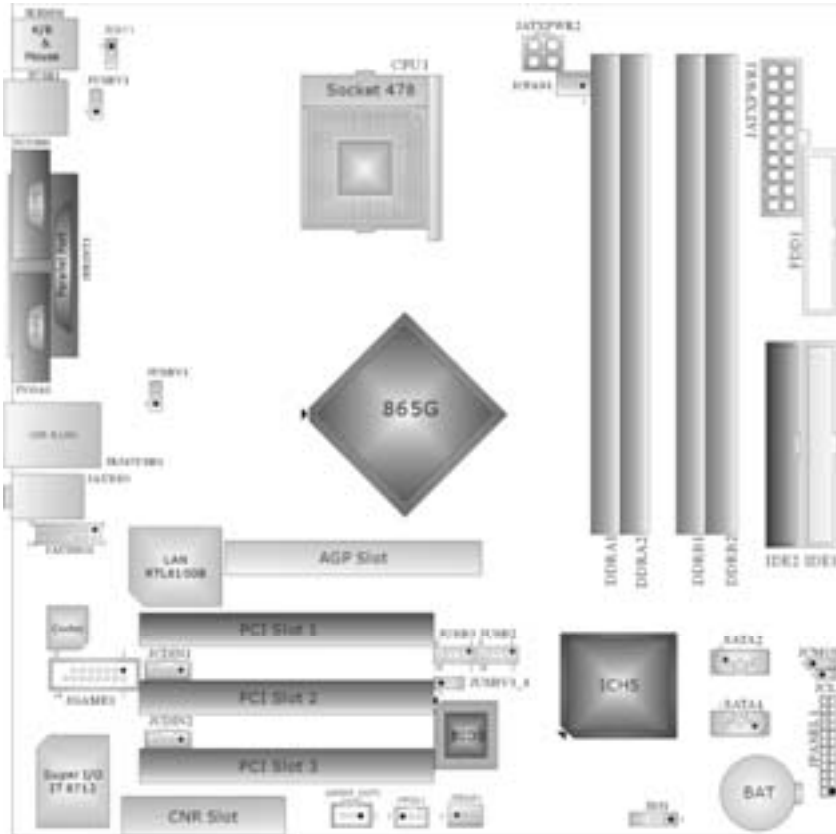

Layout of P4TSV Version 7.0

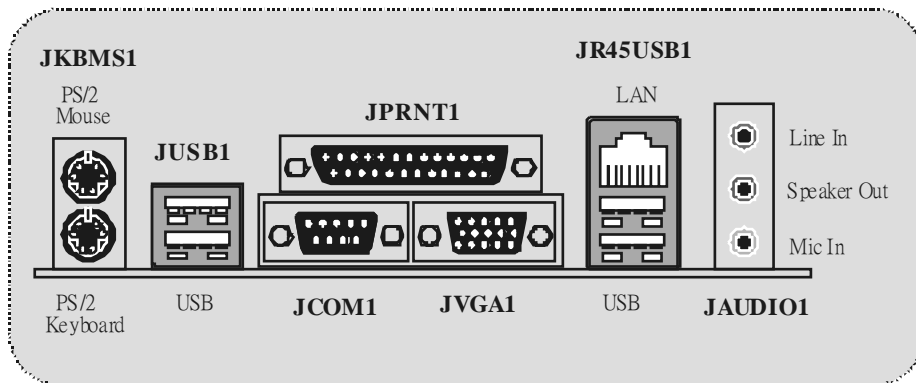
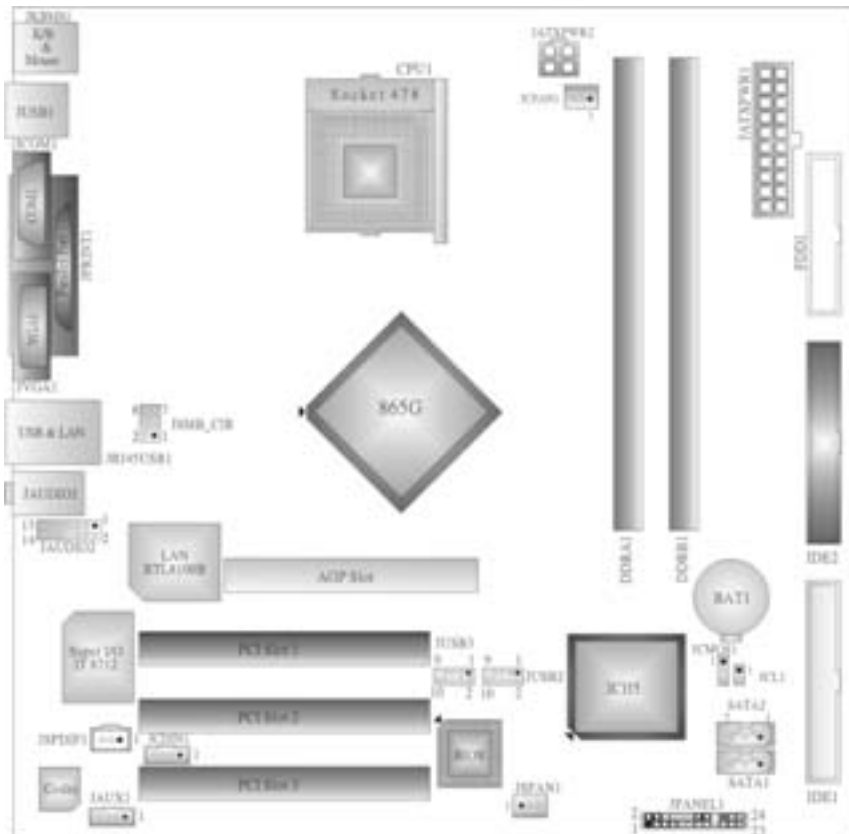

English

P4 TSV Features

A. Hardware

CPU

- Provides Socket-478.
- Supports the Intel Pentium 4 processor up to 3.06GHz.
- Supports Northwood and Prescott (Socket 478) CPU, up to 3.2 GHz. (Willamette not supported)
- Front Side Bus at 400/533/800MHz.
- Supports Intel Hyper-Threading Technology.

Chipset

- North Bridge: Intel 865G.
- South Bridge: Intel ICH5.

Main Memory

- Supports one or two 64-bit wide DDR data channels with 1 or 2 DIMMs per-channel. (Version 7.0 supports only 1 DIMM per-channel.)
- Available bandwidth up to 3.2GB/s(DDR400) for single-channel mode and 6.4GB/s (DDR 400) in dual channel mode.
- Supports 128-MB, 256-Mb, 512-Mb and 1-GB DDR technologies.
- Supports only x8, x16 DDR devices. (Does not support registered DIMMs or double sided X 16 DIMMs)
- Supports four bank devices, Dual channel DDR266/333/400 MHz
- Supports up to 4GB memory size without ECC. (2GB for version 7.0)

Super I/O

- Chip: ITE IT8712F.
- Low Pin Count Interface.
- Provides the most commonly used legacy Super I/O functionality.
- Environment Control initiatives,
 - H/W Monitor
 - Fan Speed Controller
 - ITE's "Smart Guardian" function

Slots

- Three 32-bit PCI bus master slots.
- One CNR slot. (Optional) (No CNR slot for version 7.0)
- One AGP 4X/8X slot.

On Board IDE

- Supports four IDE disk drives
- Provides PIO Mode 0-4, Bus Master, and Ultra DMA 33/66/100 function.

-
-
- Serial ATA/150 controller integrated in ICH5.
 - Can connect up to two Serial ATA (SATA) drives.
 - Up to 150MB/sec transfer speeds
 - Compliant with SATA 1.0 specification

LAN

- Chip: RTL8100B.
- Supports 10 Mb/s and 100 Mb/s auto-negotiation.
- Half/Full duplex capability.
- Supports ACPI power management.

On Board AC'97 Sound Codec

- Chip: CMI9739A/(CMI9761A for version 7.0)
- Compliant with AC'97 specification.
- AC97 2.2 interface or CMI9739A/ AC97 2.3 interface for CMI9761A.
- Supports 6 channels.
- Supports stereo microphone. (only for CMI9761A.)
- Advanced power management and power saving capabilities. (only for CMI9761A.)

On Board Peripherals

a. Rearside

- 1 serial port.
- 1 parallel port. (SPP/EPP/ECP mode)
- 1 VGA port.
- Audio ports in vertical.
- 1 RJ-45 LAN jack.
- Supports PS/2 mouse and PS/2 key board.
- 4 USB2.0 ports.

b. FrontSide

- 1 floppy port supports 2 FDDs with 360K, 720K, 1.2M, 1.44M and 2.88Mbytes.
- 4 USB2.0 ports.

Dimensions

- Micro ATX Form Factor: 24.4 X24.4cm (W X L)
- Micro ATX Form Factor: 23.6 X22.7cm (W X L) (for version 7.0)

B. BIOS & Software

BIOS

- Award legal BIOS.
 - Supports APM1.2.
 - Supports ACPI.
 - Supports USB Function.
-
-

Software

- Supports Warpspeeder™, 9th Touch™, FLASHER™, StudioFun!™ (optional).
- Offers the highest performance for Windows 98 SE, Windows 2000, Windows Me, Windows XP, SCO UNIX etc.

Package contents

- HDD Cable X 2
- FDD Cable X1
- User's Manual X1
- Fully Setup Driver CD X1
- StudioFun! Application CD X1 (optional)
- USB 2.0 Cable X1 (optional)
- S/PDIF Cable X 1 (optional)
- Rear I/O Panel for Micro ATX Case X1 (optional)
- Serial ATA Cable X1 (optional)
- Serial ATA Power Switch Cable X1 (optional)

How to set up a Jumper?

The illustration shows to how set up a jumper. When the Jumper cap is placed on pins, the jumper is "close". If no jumper cap is placed on the pins, the jumper is "open". The illustration shows a 3-pin jumper whose pin 1 and 2 are "close" when jumper cap is placed on these 2 pins.



Jumper open



Jumper close

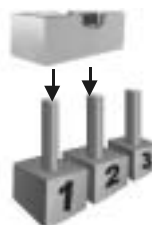

Pin1-2 close

CPU Installation

Step1: Pull the lever sideways away from the socket and then raise the lever up to a 90-degree angle.

Step2: Look for the white dot/cut edge. The white dot/cut edge should point wards the lever pivot. The CPU will fit only in the correct orientation.

Step3: Hold the CPU down firmly, and then close the lever to complete the installation.

Step4: Put the CPU Fan on the CPU and buckle it. Connect the CPU fan power cable to the JCFAN1. This completes the installation.

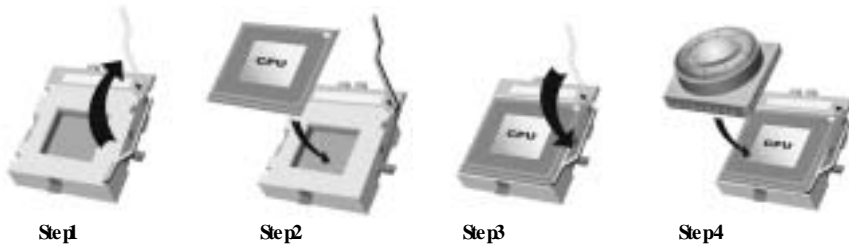

CPU Fan Headers: JCFAN1

 JCFAN1	Pin	Assignment
	1	Ground
	2	+12V
	3	FAN RPM Sense

System Fan Headers: JSFAN1

 JSFAN1	Pin	Assignment
	1	Ground
	2	+12V
	3	FAN RPM Sense

DDR DIMM Modules: DDRA1, DDRB1 (for v.7.0 only)

■ Supports up to 2 DDR DIMMs (one DIMM per channel), single-sided and/ or double-sides.

DRAM Access Time: 2.5V Unbuffered/ no registered (without ECC) DDR SDRAM
PC2100/ PC2700/ PC3200 Type required.

DRAM Type: 128MB/ 256MB/ 512MB/ 1GB DIMM Module (184 pin)

Total Memory Size with Unbuffered/ Registered DIMMs

DIMM Socket Location	DDR Module	Total Memory Size (MB)
DDRA1	128MB/256MB/512MB/1GB*1	Max is
DDRB1	128MB/256MB/512MB/1GB *1	2GB

Only for reference

DDR DIMM Modules: DDRA1-2, DDRB1-2

■ Supports up to four DDR DIMMs (two DIMMs per channel), single-sided and/ or double-sides.

■ For Dual Channel Operation, DIMMs must be populated in identical pairs. It has to be the combination of DDRA1+DDRB1 (Blue DIMMs) or DDRA2+DDRB2 (white DIMMs). For more dual channel operation information please log on: www.biostar.com.tw

DRAM Access Time: 2.5V Unbuffered/ no registered (without ECC) DDR SDRAM
PC2100/ PC2700/ PC3200 Type required.

DRAM Type: 128MB/ 256MB/ 512MB/ 1GB DIMM Module (184 pin)

Total Memory Size with Unbuffered/ Registered DIMMs

DIMM Socket Location	DDR Module	Total Memory Size (MB)
DDRA1	128MB/256MB/512MB/1GB*1	Max is 4GB
DDRA2	128MB/256MB/512MB/1GB *1	
DDRB1	128MB/256MB/512MB/1GB *1	
DDRB2	128MB/256MB/512MB/1GB *1	

Only for reference

Installing DDR Module

1. Unlock a DIMM slot by pressing the retaining clips outward. Align a DIMM on the slot in the way that the notch of the DIMM matches the break of the slot.
2. Insert the DIMM vertically and firmly into the slot until the retaining chip snap back in place and the DIMM is properly seated.



Jumpers, Headers, Connectors & Slots

Floppy Disk Connector: FDD1

The motherboard provides a standard floppy disk connector that supports 360K, 720K, 1.2M, 1.44M and 2.88M floppy disk types. This connector supports the provided floppy drive ribbon cables.

Hard Disk Connectors: IDE1/ IDE2

The motherboard has a 32-bit Enhanced PCI IDE Controller that provides PIO Mode 0-5, Bus Master, and Ultra DMA 33/ 66/ 100 functionality. It has two HDD connectors IDE1 (primary) and IDE2 (secondary).

The IDE connectors can connect a master and a slave drive, so you can connect up to four hard disk drives. The first hard drive should always be connected to IDE1.

Peripheral Component Interconnect Slots: PCI1-3

This motherboard is equipped with 3 standard PCI slots. PCI stands for Peripheral Component Interconnect, and it is a bus standard for expansion cards. This PCI slot is designated as 32 bits.

Accelerated Graphics Port Slot: AGP1

Your monitor will attach directly to that video card. This motherboard supports video cards for PCI slots, but it is also equipped with an Accelerated Graphics Port (AGP). An AGP card will take advantage of AGP technology for improved video efficiency and performance, especially with 3D graphics.

Communication Network Riser Slot: CNR1 (not for version 7.0)

The CNR specification is an open Industry Standard Architecture, and it defines a hardware scalable riser card interface, which supports modem only.

Serial ATA Connector: JSATA1/JSATA2

The motherboard has a PCI to SATA Controller with 2 channels SATA interface, it satisfies the SATA 1.0 spec and can transfer data with 150MB/sec speed.

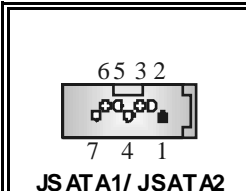

 JSATA1/ JSATA2	Pin	Assignment	Pin	Assignment
	1	Ground	2	TX+
	4	TX-	4	Ground
	5	RX-	6	RX+
	7	Ground		

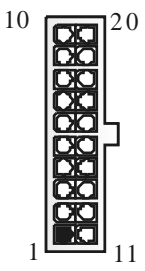
Power Connectors: JATXPWR1/ JATXPWR2

 <p>JATXPWR1</p>	PIN	Assignment	PIN	Assignment
	1	+3.3V	11	+3.3V
	2	+3.3V	12	-12V
	3	Ground	13	Ground
	4	+5V	14	PS_ON
	5	Ground	15	Ground
	6	+5V	16	Ground
	7	Ground	17	Ground
	8	PW_OK	18	-5V
	9	+5V_Standby	19	+5V
10	+12V	20	+5V	

 <p>JATXPWR2</p>	PIN	Assignment	PIN	Assignment
	1	+12V	3	Ground
	2	+12V	4	Ground

Clear CMOS Jumper: JCMOS1

JCMOS1	Assignment
 Pin 1-2 Close	Normal Operation (default)
 Pin 2-3 Close	Clear CMOS Data



※ Clear CMOS Procedures :

1. Remove AC power line.
2. Set the jumper to "Pin 2-3 Close".
3. Wait for five seconds.
4. Set the jumper to "Pin 1-2 Close".
5. Power on the AC.
6. Reset your desired password or clear the CMOS data.

Front Panel Connector: JPANEL1

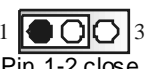

Pin	Assignment	Function	Pin	Assignment	Function
1	+5V	Speaker Connector	2	Sleep Control	Sleep Button
3	NA		4	Ground	
5	NA		6	NA	NA
7	Speaker		8	Power LED (+)	POWER LED
9	HDD LED (+)	10	Power LED (+)		
11	HDD LED (-)	12	Power LED (-)		
13	Ground	Reset Button	14	Power Button	Power-on Button
15	Reset Control		16	Ground	
17	NA	IrDA Connector	18	KEY	IrDA Connector
19	NA		20	KEY	
21	+5V		22	Ground	
23	IRTX		24	IRRX	

5V / 5VSB Selection for KB: JKBV1 (optional, not for v.7.0)

JKBV1	Assignment	Description
 Pin 1-2 close	+5V	5V for key board and mouse
 Pin 2-3 close	+5V_Standby	5V standby for keyboard and mouse to power on your system

Note: In order to support this function "Power-on system via keyboard and mouse", "JKBV1" jumper cap should be placed on pin 2-3.

**Power Selection for USB: JUSBV1/ JUSBV2/JUSBV3_4:
optional (not for v.7.0)**

JUSBV1/JUSBV2/ JUSBV3_4	Assignment	Description
 Pin 1-2 close	+5V	JUSBV1: 5V for JUSB1 port JUSBV2: 5V for JRJ45USB1 port JUSBV3_4: 5V for JUSB2/3 ports
 Pin 2-3 close	+5V_Standby	JUSBV1: 5V standby to power on JUSB1 port JUSBV2: 5V standby to power on JRJ45USB1 port JUSBV3_4: 5V standby to power on JUSB2/3 ports

Note: 1. In order to support this function "Power-on system via USB device", "JUSBV1/ JUSBV2/ JUSBV3" jumper cap should be placed on pin 2-3 respectively.

2. If you are under S3 mode, we recommend you to select +5V Standby Voltage.

Case Open Connector: JCL1

 JCL1	Pin	Assignment
	1	Case Open Signal
	2	Ground

AUDIO DJ Connector: JDJ1 (optional)

 JDJ1	Pin	Assignment	Pin	Assignment
	1	SMBDATA	2	SMBCLK
	3	INT_B	4	KEY
	5	ATX_PWROK		

Digital Audio Connector: JSPDIF_OUT1/(JSPDF1: for v7.0)

 <p>JSPDIF_OUT1</p>	Pin	Assignment
	1	+5V
	2	SPDIF_OUT
	3	Ground

CD-ROM Audio-In Header: JCDIN1/(JCDIN2: optional)

 <p>JCDIN1/2</p>	Pin	Assignment
	1	Left Channel Input
	2	Ground
	3	Ground
	4	Right Channel Input

Game Header: JGAME1 (optional)

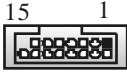
 <p>JGAME1</p>			
Pin	Assignment	Pin	Assignment
1	+5V	2	+5V
3	GP6	4	GP4
5	GP2	6	GP0
7	MIDI-OUTR	8	Ground
9	GP3	10	Ground
11	GP7	12	GP1
13	MIDI-INR	14	GP5
15	NA	16	+5V

Wake On LAN Header: JWOL1 (optional)

 <p>JWOL1</p>	Pin	Assignment
	1	+5V_Standby
	2	Ground
	3	Wake up

Front Panel Audio Header: JAUDIO1 (JAUDIO2 for v7.0)

<p style="text-align: center;">JAUDIO1(/2: for v7.0)</p>			
Pin	Assignment	Pin	Assignment
1	Mic In	2	Ground
3	Mc Power	4	Audio Power
5	RT Line Out	6	RT Line Out
7	Reserved	8	Key
9	LFT Line Out	10	LFT Line Out
11	RT Line In	12	RT Line In
13	LET Line In	14	LET Line In

Front USB Header: JUSB2/3

<p style="text-align: center;">JUSB2/3</p>			
Pin	Assignment	Pin	Assignment
1	+5V(fused)	2	+5V(fused)
3	USBP	4	USBP
5	USBP	6	USBP
7	Ground	8	Ground
9	KEY	10	NA

Auxiliary Audio-In Connector: JAUX1 (only for version 7.0)

<p style="text-align: center;">JAUX1</p>	
Pin	Assignment
1	Left channel AUX_IN
2	CD_Ground
3	CD_Ground
4	Right channel AUX_IN

Consumer Infrared Header: JSMB_CIR (only for version 7.0)

<p style="text-align: center;">J_CIR</p>			
Pin	Assignment	Pin	Assignment
1	Ground	2	+5V Standby
3	CIRRX	4	CIRTX
5	NA	6	Power-on Button
7	SMBDT	8	SMBCK

6 Channel Speakers

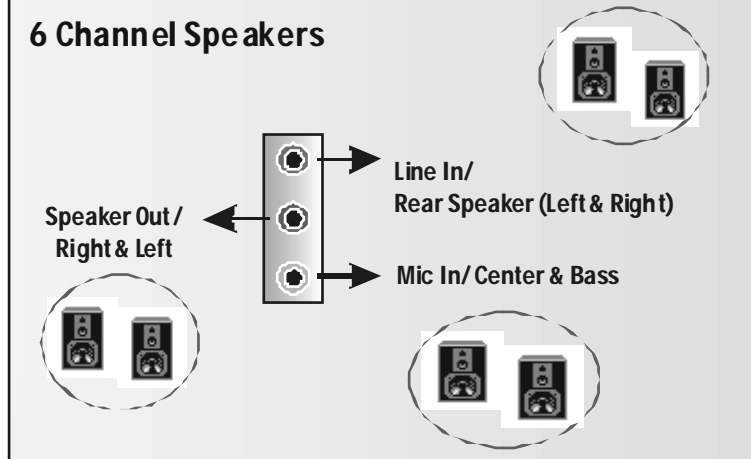

Español

Características del P4TSV

A. Hardware

CPU

- Proporciona Socket-478.
- Soporta procesador Intel Pentium 4 de hasta 3.06GHz.
- Front Side Bus a 400/533/800MHz.
- Soporta Hyper-Threading.
- Soporta Northwood y Prescott CPU de hasta 3.2GHz. (No soporta CPU Willamette)

Chipset

- North Bridge: Intel 865G
- South Bridge: Intel ICH5.

Memoria Principal

- Soporta una o dos DDR canal de datos de 64-bit wide con 1 o 2 DIMMs por canal.
- Banda ancha disponible hasta 3.2GB/s (DDR400) para modo de canal simple y modo de canal doble 6.4GB/s (DDR 400).
- Soporta tecnología DDR de 128-MB, 256-Mb, 512-Mb y 1 GB.
- Soporta solamente dispositivos DDR x8, x16. (No soporta DIMMs registered o DIMMs de doble cara X 16)
- Soporta dispositivos de 4 bancos.
- Tamaño de memoria máxima 4GB (no ECC).

Super I/O

- Chip: ITE IT8712F.
- Interface Low Pin Count.
- Proporciona funcionalidad legacy Super I/O.
- Environment Control initiatives,
 - H/W Monitor
 - Controlador Fan Speed
 - Función ITE "Smart Guardian"

Ranuras

- Tres ranuras de 32-bit PCI bus master.
- Una ranura CNR.
- Una ranura AGP 4X/ 8X.

IDE Onboard

- Soporta cuatro discos IDE.
- Soporta modo PIO 0~4, Ultra DMA 33/66/100 Bus Modo Master.
- Soporta 2 puertos Serial ATA (SATA).
 - Conformar con la especificación SATA 1.0

-
-
- Transferencia de datos de hasta 150MB/s

LAN

- Chip: RTL8100B.
- Soporta 10 Mb/s y 100 Mb/ auto-negociación
- Capacidad Half/ Full duplex.
- Soporta administración ACPI

AC'97 Sound Codec Onboard

- Chip: CMI9739A/CMI9739A (parav.7.0).
- Conformar con la especificación AC'97.
- Interface AC97 2.2 para CMI9739A/ Interface AC97 2..3 para CMI9761A.
- Soporta 6 canales.
- Soporta micrófono estereo.

Periféricos Onboard

a. Parte Trasera

- 1 puerto serie.
- 1 puerto paralelo. (modo SPP/EPP/ECP)
- 1 puerto VGA.
- Puerto de Audio vertical.
- 1 LAN RJ-45.
- Soporta ratón PS/2 y teclado PS/2.
- 4 puertos USB2.0.

b. Parte Frontal

- 1 puerto para disquetera soporta 2 FDDs con 360K, 720K, 1.2M, 1.44M y 2.88 Mbytes.
- 4 puertos USB2.0.

Dimensiones

- Forma de Factor Micro ATX: 24.4 X 24.4cm (W X L)
- Forma de Factor Micro ATX: 24.4 X 22.7cm (W X L) (V.7.0)

B. BIOS & Software

BIOS

- Award legal BIOS.
- Soporta APM1.2.
- Soporta ACPI.
- Soporta función USB.

Software

- Soporta Warpspeeder™, 9th Touch™, FLASHER™, StudioFun!™ (opcional).
- Ofrece el más alto funcionamiento para Windows 98 SE, Windows 2000, Windows Me, Windows XP, SCO UNIX etc.

Contenido del Paquete

- Cable HDD X 2
- Cable FDD X1
- Manual del Usuario X1
- Configuración Completa del Driver CD X1
- Aplicación StudioFun! CD X1 (opcional)
- Cable USB 2.0 X1 (opcional)
- Cable S/PDIF X 1 (opcional)
- Panel Trasero I/O para carcasa Micro ATX X1 (opcional)
- Cable Serial ATA X1 (opcional)
- Cable de Interruptor de Corriente para Serial ATA X1 (opcional)

Cómo instalar un Puente

La ilustración muestra cómo instalar un puente. Cuando el Jumper Cap está ubicado en los contactos, el puente está en "close". Si no hay Jumper Cap ubicado en los contactos, el puente está en "open". La siguiente ilustración muestra un contacto 3 en el que los contactos 1 y 2 están "close" cuando el Jumper Cap está ubicado en los dos contactos.



Puente open



Puente close

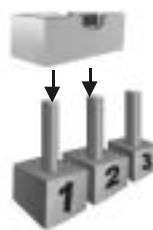

Contacto 1-2 close

Instalación del CPU

Paso 1: Empuje la palanca hacia afuera del socket y levante la palanca hasta un ángulo de 90 grados.

Paso 2: Fijese por el punto blanco o margen cortado. El punto blanco o margen cortado debería apuntar hacia el pivote de la palanca. La CPU solamente se fijará en una sola correcta orientación.

Paso 3: Tome el CPU firmemente hacia abajo, y cierre la palanca para completar la instalación.

Paso 4: Ponga el ventilador de la CPU en el CPU y asegúrelo. Conecte el cable de

corriente del ventilador de la CPU al JCFAN1. Ésto completa la instalación.

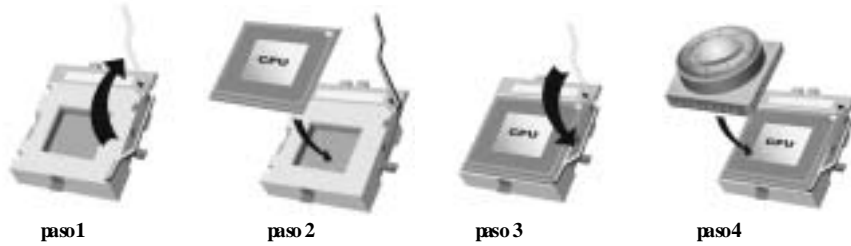

Cabezal del Sistema de Ventilación del CPU: JCFAN1

 JCFAN1	Contacto	Asignación
	1	Tierra
	2	+12V
	3	FAN RPM Sense

Cabezal del Sistema de Ventilación: JSFAN1

 JSFAN1	Contacto	Asignación
	1	Tierra
	2	+12V
	3	FAN RPM Sense

Módulos DDR DIMM: DDRA1-2, DDRB1-2

■ Soporta hasta cuatro DDR DIMMs (dos DIMMs por canal), doble o y una cara.

■ Para manejarse con el Dual Channel, los DIMMs deben ser insertados en pares idénticos. Debe ser la combinación del DDRA1+DDRB1 (DIMMs azules) o DDRA2+DDRB2 (DIMMs blancos). Para más información sobre la operación del Dual Channel por favor entre a la página web: www.biostar.com.tw

DRAM Tiempo de Acceso: 2.5V Unbuffered/ no registered (sin ECC) DDR
SDRAM PC2100/ PC2700/ PC3200 Tipo requerido.

DRAM Tipo: 128MB/ 256MB/ 512MB/ 1GB Módulo DIMM (184 contactos)

Total del Tamaño de la Memoria con Unbuffered/ Registered DIMMs

Localización del Socket DIMM	Módulo DDR	Total del Tamaño de la Memoria (MB)
DDRA1	128MB/256MB/512MB/1GB*1	Máxima 4GB
DDRA2	128MB/256MB/512MB/1GB *1	
DDRB1	128MB/256MB/512MB/1GB *1	
DDRB2	128MB/256MB/512MB/1GB *1	

Solamente para referencia

Módulos DDR DIMM: DDRA1, DDRB1 (para v.7.0)

■ Soporta hasta 2DDR DIMMs (dos DIMMs por canal), doble o/ una cara.

DRAM Tiempo de Acceso: 2.5V Unbuffered/ no registered (sin ECC) DDR
SDRAM PC2100/ PC2700/ PC3200 Tipo requerido.

DRAM Tipo: 128MB/ 256MB/ 512MB/ 1GB Módulo DIMM (184 contactos)

Total del Tamaño de la Memoria con Unbuffered/ Registered DIMMs

Localización del Socket DIMM	Módulo DDR	Total del Tamaño de la Memoria (MB)
DDRA1	128MB/256MB/512MB/1GB*1	Máxima 2 GB
DDRB1	128MB/256MB/512MB/1GB *1	

Solamente para referencia

Instalación del Módulo DDR

1. Abra una ranura de DIMM presionando el clip de retención hacia afuera. Alinee el DIMM en la ranura tales que la muesca en el DIMM encaje en la cubrera de la ranura.
2. Inserte el DIMM verticalmente y firmemente en la ranura hasta que el clip de retención vuelva a su posición original y el DIMM esté correctamente colocado.



Puentes, Cabezales, Conectores y Ranuras

Conector de Disquetera: FDD1

La placa madre proporciona un conector estándar para disquete que soporta disquetera de 360K, 720K, 1.2M, 1.44M y 2.88M. Este conector utiliza cables proporcionados por el disquete.

Conector del Disco Duro: IDE1/ IDE2

La placa madre tiene un controlador de 32-bit PCI IDE que proporciona Modo PIO 0-5, Bus Master, y funcionalidad Ultra DMA 33/ 66/ 100. Tiene dos conectores HDD: IDE1 (primario) y IDE2 (secundario).

Los conectores IDE puede conectar a un disco maestro y uno esclavo, así puede conectar hasta cuatro discos duros. El primer disco duro debe estar siempre conectado al IDE1.

Ranuras de Interconexión del Componente Periférico: PCI-3

Esta placa madre está equipada con 3 ranuras estándar PCI. PCI es la sigla para Interconexión del Componente Periférico, y es un bus estándar para tarjetas de expansión. Esta ranura PCI está diseñado con 32 bits.

Ranura del Puerto Acelerado para Gráficos: AGP1

Su monitor se fijará directamente a la tarjeta de video. Esta placa madre soporta tarjetas de video para ranuras PCI, pero también está equipado con un puerto AGP. La tarjeta AGP tomará ventaja de la tecnología del AGP para el mejoramiento de la eficiencia y funcionamiento del video, especialmente con gráficos 3D.

Ranura de Banda de Suspensión de Comunicación y Red: CNR1 (no para v.7.0)

La especificación CNR es una abierta Industria de Arquitectura Estándar, que define una tarjeta de interfaz escalable del hardware en el que soporta solamente modem.

Conector Serial ATA: JSATA1/JSATA2

La placa madre tiene un controlador PCI al SATA con 2 canales SATA de interfaz, que satisface SATA 1.0 spec y transfiere datos a una velocidad de 1.5GHz.

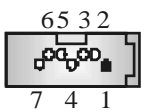
 JSATA1/ JSATA2	Contactos	Asignación	Contactos	Asignación
	1	Tierra	2	TX+
	4	TX-	4	Tierra
	5	RX-	6	RX+
	7	Tierra		

Conector del Panel Frontal: JPANEL1

Con-tactos	Asignación	Función	Con-tactos	Asignación	Función
1	+5V	Conector del Altavoz	2	Control de Suspension	Botón de Suspension
3	NA		4	Tierra	
5	NA		6	NA	NA
7	Altavoz		8	Corriente LED (+)	Corriente LED
9	HDD LED (+)	10	Corriente LED (+)		
11	HDD LED (-)	12	Corriente LED (-)		
13	Tierra	Botón de Reinicio	14	Botón de Encendido	Botón de Encendido
15	Control de Reinicio		16	Tierra	
17	NA	Conector IrDA	18	KEY	Conector IrDA
19	NA		20	KEY	
21	+5V		22	Tierra	
23	IRTX		24	IRRX	

Cabezal de Entrada de Audio CD-ROM: JCDIN1/ JCDIN2



 JCDIN1/2	Contac-tos	Asignación
	1	Entrada del Canal Izquierdo
	2	Tierra
	3	Tierra
	4	Entrada del Canal Derecho

Conectores de Corriente: JATXPWR1/ JATXPWR2

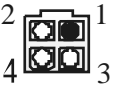
 <p>JATXPWR1</p>	Con- tactos	Asignación	Con- tactos	Asignación
	1	+3.3V	11	+3.3V
	2	+3.3V	12	-12V
	3	Tierra	13	Tierra
	4	+5V	14	PS_ON
	5	Tierra	15	Tierra
	6	+5V	16	Tierra
	7	Tierra	17	Tierra
	8	PW_OK	18	-5V
	9	+5V_SB	19	+5V
10	+12V	20	+5V	

 <p>JATXPWR2</p>	Con- tactos	Asignación	Con- tactos	Asignación
	1	+12V	3	Tierra
	2	+12V	4	Tierra



5V / 5VSB Selección para KB: JKBV1 (no para v.7.0)

JKBV1	Asignación	Descripción
 <p>Contacto 1-2 close</p>	+5V	5V para teclado y ratón
 <p>Contacto 2-3 close</p>	+5V_SB	5V standby de teclado y ratón para encender su sistema



Conector de la Carcasa Abierta: JCL1

 <p>JCL1</p>	Con- tactos	Asignación
	1	Señal de la Carcasa Abierta
	2	Tierra

5V/ 5VSB Selección para USB: JUSBV1/ JUSBV2/JUSBV3_4 (no para v.7.0)

JUSBV1/JUSBV2/ JUSBV3_4	Asignación	Description
 Contacto 1-2 close	+5V	5V JUSBV1 para puertoJUSB1 5V JUSBV2 para puerto JRJ45USB1 5V JUSBV3_4 para puertoJUSB2/3
 Contacto 2-3 close	+5V_SB	JUSBV1 5V standby para encender el puerto JUSB1 JUSBV2 5V standby para encender el puerto JRJ45USB1 JUSBV3_4 5V standby para encender los puertos JUSB2/3

Borrar Puente CMOS: JCMOS1

JCMOS1	Asignación
 Pin 1-2 Close	Operación Normal (default)
 Pin 2-3 Close	Borra datos CMOS

※ Procedimientos para Borrar CMOS:

1. Quite el cable de corriente del AC.
2. Fijar el puente en el "contacto 2-3 close".
3. Espere 5 segundos.
4. Fijar el Puente en el "contacto 1-2 close".
5. Encienda AC.
6. Reconfigure la contraseña deseada o borre datos CMOS.

Conector Audio DJ: JDJ1 (opcional)

 JDJ1		Con- tactos	Asignación	Con- tactos	Asignación
	1	1	SMBDATA	2	SMBCLK
	3	3	INT_B	4	KEY
	5	5	ATX_PWROK		

Cabezal de Juego: JGAME1 (opcional)

 JGAME1			
Contactos	Asignación	Contactos	Asignación
1	+5V	2	+5V
3	GP6	4	GP4
5	GP2	6	GP0
7	MIDI-OUTR	8	Tierra
9	GP3	10	Tierra
11	GP7	12	GP1
13	MIDI-HNR	14	GP5
15	NA	16	+5V

Cabezal del Panel Frontal de Audio: JAUDIO1(/2 para v7.0)

 JAUDIO1/2			
Contacto	Asignación	Contacto	Asignación
1	Entrada del Mc	2	Tierra
3	Corriente del Mc	4	Corriente de Audio
5	Salida de Línea RT	6	Salida de Línea RT
7	Reservado	8	Key
9	Salida de Línea LFT	10	Salida de Línea LFT
11	Entrada de Línea RT	12	Entrada de Línea RT
13	Entrada de Línea LET	14	Entrada de Línea LET

Conector de Audio Digital: JSPDIF_OUT1/(JSPDF1 para v.7.0)

 JSPDIF_OUT1	Contactos	Asignación
	1	+5V
	2	SPDIF_OUT
	3	Tierra

Cabecal Wake On LAN: JWOL1 (opciona)

 JWOL1	Contacto	Asignación
	1	+5V_SB
	2	Tierra
	3	Wake up

Cabecal Frontal USB: JUSB2/3

 JUSB2/3	Con-tactos	Asignación	Con-tactos	Asignación
	1	+5V(f used)	2	+5V(fused)
	3	USBP	4	USBP
	5	USBP	6	USBP
	7	Tierra	8	Tierra
	9	KEY	10	NA

Conectores del Panel Trasero

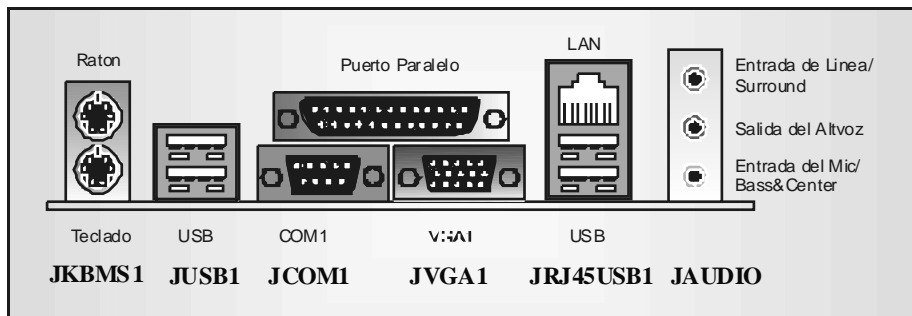

Deutsch

Spezifikationen von P4TSV

A. Hardware

CPU

- Unterstützung für Sockel 478.
- Unterstützung für den Intel Pentium 4 Prozessor bis zu 306GHz.
- FSB mit 400/533/800MHz.
- Unterstützung für Hyper-Threading-Technologie.
- Unterstützung für Northwood und Prescott (Sockel 478) CPU. (Willamette wird nicht untergestützt), bis zu 3.2GHz.

Chipsatz

- Northbridge: Intel 865G.
- Southbridge: Intel ICH5.

Hauptspeicher

- Unterstützung für ein oder zwei 64-Bit Breite DDR-Daterkanal mit ein oder zwei DIMMs pro Kanal.
- Verfügbare Bandbreite bis zu 3.2GB/s (DDR400) für Einzel-Kanal-Modus und 6.4GB/s (DDR 400) in Dual-Kanal-Modus.
- Unterstützung für 128-MB, 256-Mb, 512-Mb und 1-GB DDR Technologien.
- Unterstützung für x8 x16 DDR Geräte. (Registrierte DIMMs oder doppelseitig X 16 DIMMs werden nicht untergestützt)
- Unterstützt auf maximal vier DDR Geräte.
- Die maximale Speichergröße ist 4GB ohne ECC.

Super I/O

- Chip: ITE IT8712F.
- Low Pin Count Interface.
- Die meisten gemeinsamen verbrauchten Super I/O Funktionen werden geliefert.
- Umweltkontroll-Initiative:
 - H/W Monitor
 - Ventilator-Geschwindigkeit-Controller
 - ITE's "Smart Guardian" Funktion

Slots

- Drei 32-Bit PCI-Bus-Slots.
- Ein CNR-Slot.
- Ein AGP 4X/8X Slot.

Onboard-IDE

- Unterstützung für vier IDE Diskettenlaufwerke.
- Unterstützung für PIO Modus 0~4, Ultra DMA 33/66/100 Bus Master Modus.

-
-
- Unterstützung für zwei Serial-ATA-Ports (SATA).
 - Entspricht der Spezifikation von SATA 1.0
 - Datenübertragung bis auf maximal 150MB/s

LAN

- Chip: RTL8100B.
- Unterstützung für 10 Mb/s und 100 Mb/s Auto-Negotiation.
- Halb/Voll-Duplex Fähigkeit.
- Unterstützung für ACPI Power Management

Onboard AC'97 Sound Codec

- Chip: CMI9739A/CMI9761A (für V.7.0)
- Entspricht der Spezifikation von AC'97.
- AC97 2.2 Interface für CMI9739A/ AC972.3 Interface für CMI9761A.
- Unterstützung für 6-Kanal.
- Unterstützung für stereo microphone.

Onboard-Peripheriegeräte

a. Rückwand

- 1 serielle Schnittstelle.
- 1 parallele Schnittstelle. (SPP/EPP/ECP Modus)
- 1 VGA Schnittstelle
- 1 vertikale Audio-Schnittstelle.
- 1 RJ-45 LAN Jack.
- Unterstützung PS/2-Maus und PS/2-Tastatur.
- 4 USB2.0-Ports.

b. Vorderseite

- 1 Floppy -Port mit Unterstützung für 2 Diskettenlaufwerke. (360KB, 720KB, 1.2MB, 1.44MB und 2.88MB)
- 4 USB2.0-Ports.

Abmessungen

- Micro ATX Form Factor: 24.4 X 24.4 cm (W X L)
- Micro ATX Form Factor: 24.4 X 22.7 cm (W X L) (für v.7.0)

B. BIOS & Software

BIOS

- Award legal BIOS.
- Unterstützung für APM1.2.
- Unterstützung ACPI.
- Unterstützung USB Funktion.

Software

- Unterstützung für Warpspeeder™, 9th Touch™, Flasher™, StudioFun!™ (optional).
- Unterstützung für die am meisten verbreiteten Betriebssysteme wie Windows 98SE., Windows 2000, Windows ME, Windows XP and SCO UNIX usw..

Verpackungsinhalt

- HDD Kable X 2
- FDD Kable X1
- Benutzer Handbuch X1
- Treiber CD für Installation X1
- StudioFun! Anwendung CD X1 (optional)
- USB 2.0 Kable X1 (optional)
- S/PDIF Kable X 1 (optional)
- I/O-Rückwand für Micro ATX Gehäuse X1 (optional)
- Serial ATA Kable X1 (optional)
- Serial ATA Netzschalter Kable X1 (optional)

Einstellung der Jumper

Die Abbildung verdeutlicht, wie Jumper eingestellt werden. Pins werden durch die Jumper-Kappe verdeckt, ist der Jumper "geschlossen". Keine Pins werden durch die Jumper-Kappe verdeckt, ist der Jumper "geöffnet". Die Abbildung zeigt einen 3-Pin Jumper dessen Pin1 und Pin2 "geschlossen" sind, bzw. es befindet sich eine Jumper-Kappe auf diesen beiden Pins.



Jumper geschlossen



Jumper geöffnet

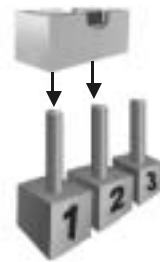

Pin 1-2 geschlossen

Installation der CPU

Schritt 1: Ziehen Sie den Hebel seitlich vom Sockel weg. Heben Sie den Hebel dann in 90-Grad-Winkel nach oben.

Schritt 2: Suchen Sie nach der scharfen Kante, die auf Drehpunkt des Hebels weisen muss. Die CPU passt nur, wenn sie richtig ausgerichtet ist.

Schritt 3: Drücken Sie die CPU fest in den Sockel und schließen Sie den Hebel.

Schritt 4: Stecken Sie Ihren CPU-Lüfter auf die CPU. Schließen Sie die Stromversorgungsstecker für CPU-Lüfter an JCFAN1 an. Dann beenden Sie die Installation.

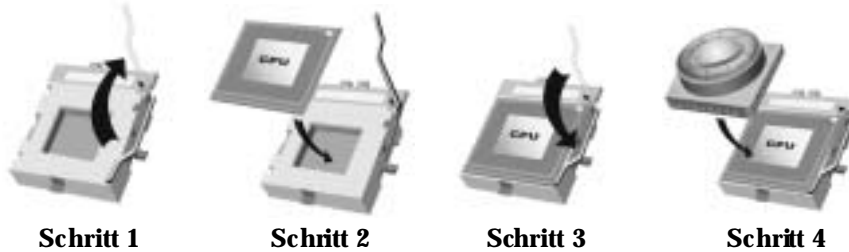

CPU Fan Headers: JCFAN1

 JCFAN1	Pin	Beschreibung
	1	Masse
	2	+12V
	3	FAN RPM Sensor

System Fan Headers: JSFAN1

 JSFAN1	Pin	Beschreibung
	1	Masse
	2	+12V
	3	FAN RPM Sensor

DDR DIMM Modules: DDRA1-2, DDRB1-2

■ Maximal werden 4 einseitig oder doppelseitig DDR-DIMMs untergestützt.(2 DIMMs pro Kanal).

■ Für Dual-Kanal Operation, daß DIMMs in indentischen Paar installiert werden müssen. Es is unbedingt, DDRA1mit DDRB1(blaue DIMMs) oder DDRA2 mit DDRB2 (weiße DIMMs) als ein Paar zu verwenden. Mehr Informationen über Dual-Kanal Operation finden Sie auf der Website von Biostar unter <http://www.biostar.com.tw>

DRAM-Zugriffszeit: 2.5V unbuffered/ nicht registrierter (ohne ECC) DDR SDRAM
PC2100/ PC2700/ PC3200 Typ erforderlich.

DRAM-Typ: 128MB/ 256MB/ 512MB/ 1GB DIMM-Module (184-Pin)

Gesamt SpeichergroÙe von nicht registrierter DIMMs

DIMM-Sockel Standort	DDR-Modul	SpeichergroÙe (MB)
DDRA1	128MB/256MB/512MB/1GB*1	maximal ist 4GB
DDRA2	128MB/256MB/512MB/1GB*1	
DDRB1	128MB/256MB/512MB/1GB*1	
DDRB2	128MB/256MB/512MB/1GB*1	

Nur als Referenz

DDR DIMM Modules: DDRA1, DDRB1 (für v7.0)

■ Maximal werden 2 einseitig oder doppelseitig DDR-DIMMs untergestützt.(2 DIMMs pro Kanal).

DRAM-Zugriffszeit: 2.5V unbuffered/ nicht registrierter (ohne ECC) DDR SDRAM
PC2100/ PC2700/ PC3200 Typ erforderlich.

DRAM-Typ: 128MB/ 256MB/ 512MB/ 1GB DIMM-Module (184-Pin)

Gesamt SpeichergroÙe von nicht registrierter DIMMs

DIMM-Sockel Standort	DDR-Modul	SpeichergroÙe (MB)
DDRA1	128MB/256MB/512MB/1GB*1	maximal ist
DDRB1	128MB/256MB/512MB/1GB*1	2GB

Nur als Referenz

Installation von DDR-Modul

1. Öffnen Sie einen DIMM-Slots, indem Sie die seitlich Chips nach außen drücken. Richten Sie das DIMM-Modul so über dem Slot aus, dass das Modul mit der Kerbe in den Slot passt.
2. Drücken Sie das DIMM-Modul in den Slot, bis die seitlichen Clips zuschnappen und das Modul fest sitzt.



Jumpers, Headers, Anschlüsse & Slots

Diskettenanschluss: FDD1

Das Motherboard enthält einen standardmäßigen Diskettenanschluss, der 360K-, 720K-, 1.2M-, 1.44M- und 2.88M-Disketten unterstützt. Dieser Anschluss unterstützt die mitgelieferte Bandkabel des Diskettenlaufwerks.

Festplattenanschlüsse: IDE1 und IDE2

Das Mainboard hat einen 32-Bit Enhanced PCI IDE-Controller, der die Modi PIO0~4, Bus Master sowie die Ultra DMA/33/66/100/133- Funktion zur Verfügung stellt. Dieser ist mit zwei HDD-Anschlüssen versehen IDE1 (primär) und IDE2 (sekundär).

Die IDE-Anschlüsse können eine Master- und eine Slave-Festplatte verbinden, so dass bis zu 4 Festplatten angeschlossen werden können. Die erste Festplatte sollte immer an IDE1 angeschlossen werden.

Peripheral Component Interconnect Slots: PCI1-3

Dieses Motherboard ist mit 3 standardmäßigen PCI-Slots ausgestattet. PCI steht für Peripheral Component Interconnect und bezieht sich auf einem Busstandard für Erweiterungskarten, der den älteren ISA-Busstandard in den meisten Schnittstellen ersetzt hat. Dieser PCI-Slot ist für 32 bits vorgesehen.

Accelerated Graphics Port Slot: AGP1

Ihr Monitor wird direkt an die Grafikkarte angeschlossen. Dieses Motherboard unterstützt Grafikkarten für PCI-Slots, aber es ist auch mit einem Accelerated Graphics Port ausgestattet. AGP-Karten verwenden die AGP-Technologie, um die Wirksamkeit und Leistung von Videosignalen zu verbessern, besonders wenn es sich um 3D-Grafiken handelt.

Communication Network Riser Slot: CNR1 (no für v7.0)

Die CNR-Angaben entsprechen einer offenen Industry Standard Architecture, und sie definieren eine Hardware-skalierbare Riser-Card-Schnittstelle, welche nur Audio, Netzwerk und Modem unterstützt.

Serial ATA Connector: JS ATA1/JS ATA2

Auf diesem Motherboard gibt es ein PCI-to-SATA Controller mit 2-Kanal Interface, die der Spezifikation von SATA 1.0 entspricht (Datenübertragung mit 1.5GB/S)

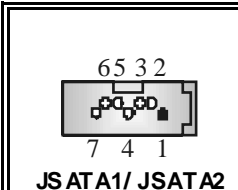

 <p>JS ATA1/ JS ATA2</p>	Pin	Beschreibung	Pin	Beschreibung
	1	Masse	2	TX+
	4	TX-	4	Masse
	5	RX-	6	RX+
	7	Masse		

Stromversorgungsanschluss: JATXPWER1/JATXPWR2

 <p>JATXPWR1</p>	PIN	Beschreibung	PIN	Beschreibung
	1	+3.3V	11	+3.3V
	2	+3.3V	12	-12V
	3	Masse	13	Masse
	4	+5V	14	PS_ON
	5	Masse	15	Masse
	6	+5V	16	Masse
	7	Masse	17	Masse
	8	PW_OK	18	-5V
	9	+5V_SB	19	+5V
10	+12V	20	+5V	

 <p>JATXPWR2</p>	PIN	Beschreibung	PIN	Beschreibung
	1	+12V	3	Masse
	2	+12V	4	Masse

Auswahl von 5V/5V_SB für USB: JUSBV1/ JUSBV2/JUSBV3_4 (no für v.7.0)



JUSBV1/JUSBV2/ JUSBV3_4	Beschreibung	Funktion
 Pin 1-2 geschlossen	+5V	JUSBV1: 5V für JUSB1 JUSBV2: 5V für JRJ45USB1 JUSBV3_4: 5V für JUSB2/3
 Pin 2-3 geschlossen	+5V_SB	JUSBV1: 5V bereit zum Reboot von JUSB1 JUSBV2: 5V bereit zum Reboot von JRJ45USB1 JUSBV3_4: 5V bereit zum Reboot von JUSB2/3

Anschlüsse für die Vorderseite: JPANEL1



*Schlüsse: Kein Pin

Pin	Beschreibung	Funktion	Pin	Beschreibung	Funktion
1	+5V	Lautsprecher Anschluss	2	Sleep Kontrollieren	Schlafen-Knopf
3	Kein		4	Masse	
5	Kein		6	Kein	Kein
7	Lautsprecher		8	Power LED (+)	POWER LED
9	HDD LED (+)	10	Power LED (+)		
11	HDD LED (-)	12	Power LED (-)		
13	Masse	Zurücksetzn	14	Power-Knopf	Power-On Knopf
15	Reset Kontrollieren	-Knopf	16	Masse	
17	Kein		18	Schlüsse	
19	Kein	IrDA-Anschluss	20	Schlüsse	IrDA Anschluss
21	+5V		22	Masse	
23	IRTX		24	IRRX	

Auswahl von 5V/5V_SB für Tastatur/Maus: JKBV1 (no für v7.0)

JKBV1	Beschreibung	Funktion
 Pin 1-2 geschlossen	+5V	5V für Tastatur und Maus
 Pin 2-3 geschlossen	+5V_SB	5V bereit für Tastatur und Maus zum Reboot von ihren System

Jumper zum Löschen CMOS : JCMOS 1

JCMOS1		Beschreibung
1	 3 Pin 1-2 geschlossen	Normale Operation (Default)
1	 3 Pin 2-3 geschlossen	CMOS-Daten Löschen

※ Prozeduren zum Löschen des CMOS:

1. Ausschalten Sie den AC-Netzstecker.
2. Lassen Sie Pin 2-3 von JCOMS1 geschlossen sein.
3. Bitte warten Sie 15 Sekunden.
4. Lassen Sie Pin 1-2 von JCOMS1 geschlossen sein.
5. Schließen Sie den AC-Netzstecker an.
6. Zurücksetzen Sie das Kennwort nach ihrem Wille oder löschen Sie die CMOS-Daten.

Anschluss für Gehäuse-Öffnen: JCL1

 JCL1		Pin	Beschreibung
		1	Gehäuse Öffnen Signal
	2	Masse	

AUDIO DJ Anschluss: JDJ1 (optional)

 JDJ1		Pin	Beschreibung	Pin	Beschreibung
		1	SMBDATA	2	SMBCLK
	3	INT_B	4	Schlüsse	
	5	ATX_PWROK			

CD-ROM Audio-In Header: JCDIN1/(JCDIN2: optional)

 JCDIN1/2		Pin	Beschreibung
		1	Link-Kanal Eingabe
	2	Masse	
	3	Masse	
	4	Recht-Kanal Eingabe	

Game Header: JGAME1 (optional)

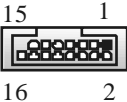
			
JGAME1			
Pin	Beschreibung	Pin	Beschreibung
1	+5V	2	+5V
3	GP6	4	GP4
5	GP2	6	GP0
7	MIDI-OUTR	8	Masse
9	GP3	10	Masse
11	GP7	12	GP1
13	MIDI-INR	14	GP5
15	Kein	16	+5V

Front Panel Audio Header: JAUDIO1 (JAUDIO2 for v.7.0)

			
JAUDIO1			
Pin	Beschreibung	Pin	Beschreibung
1	Mikrofon-Eingang	2	Masse
3	Mikrofon-Betriebsspannung	4	Audio-Spannung
5	Recht Line-Out	6	Recht Line-Out
7	Reserviert	8	Schlüsse
9	Link Line-Out	10	Link Line-Out
11	Recht Line-In	12	Recht Line-In
13	Link Line-In	14	Link Line-In

Digital Audio Anschluss: JSPDIF_OUT1/(JSPDIF1 for v.7.0)

 JSPDIF_OUT1	Pin	Beschreibung
	1	+5V
	2	SPDIF_OUT
	3	Masse

Wake On LAN Header: JWOL1 (optional)

 <p>JWOL1</p>	Pin	Beschreibung
	1	+5V_SB
	2	Masse
	3	Wake-up

Front USB Header: JUSB2/3

 <p>JUSB2/3</p>	Pin	Beschreibung	Pin	Beschreibung
	1	+5V(geschmelzt)	2	+5V(geschmelzt)
	3	USBP	4	USBP
	5	USBP	6	USBP
	7	Masse	8	Masse
	9	Schlüsse	10	Kein

Anschlüsse für die Rückwand

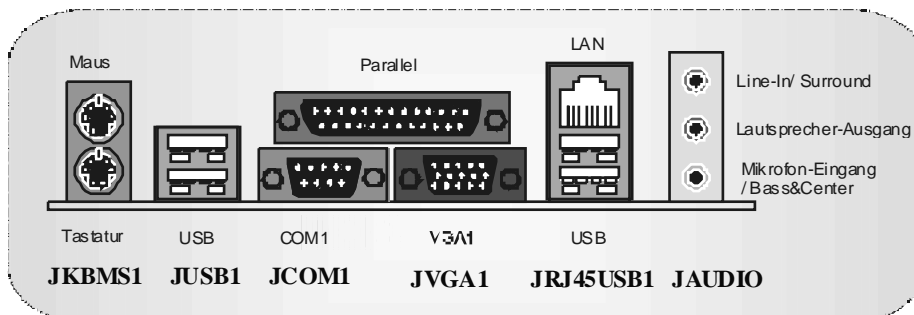

Français

Caractéristiques de P4TSV

CPU

- Offre les Socket-478.
- Supporte le processeur Intel Pentium 4 jusqu'à 3.06GHz.
- Supporte Intel Pentium 4 Northwood CPU. (Willamette not supported)
- Supporte Intel Pentium 4 478 Prescott CPU jusqu'à 3.2GHz..
- Fonctionnant en Bus Frontal de 400/ 533/800MHz
- Supporte Hyper-Threading. (seulement pour onboard VGA)

Chipset

- North Bridge: Intel 865G
- South Bridge: Intel ICH5

Mémoire Principale

- Prend en charge un ou deux canaux de données DDR de 64 bits de large avec 1 DIMM par canal.
- Bande passante disponible jusqu'à 3.2Go/s (DDR400) pour le mode canal simple et 6.4Go/s (DDR 400) pour mode canal double.
- Prend en charge les technologies DDR 128 Mo, 256 Mo, 512 Mo, 1Go.
- Prend en charge seulement les périphériques DDR x8, x16. (Ne prend pas en charge les DIMM et ECC en registres)
- Prend en charge quatre banques de mémoire.
- La taille maximum de la mémoire est de 4Go (no ECC).

Super E/S

- Puce: ITE IT8712F.
- Interface de Comptage de Broche Faible.
- Offre la fonctionnalité Super E/S héritée la plus couramment utilisée.
- Initiatives de Contrôle d'Environnement,
 - Moniteur HW
 - Fonction "Smart Guardian" de ITE

Slots

- 3 slots de maîtrise de bus PCI 32 bits.
- Un slot CNR. (optionnel)
- Un slot AGP 4X/8X.

IDE Interne

- Supporte quatre disques durs IDE.
- Supporte PIO Mode 0-4, le Mode Maître et le Mode de Maîtrise de Bus Ultra DMA 33/66/100
- Prise en charge de 2 ports série ATA (SATA).
 - conformes aux spécifications SATA 1.0.
 - vitesse de transfert des données jusqu'à 150 MB/s..

LAN (optionnel)

- RealTek RTL8100B.
- Supporte Négociation automatique : 10/100 Mb/s.
- Full/Half Duplex.

-
-
- Supporte ACPI, PCI Power management.

Codec Son AC'97 Interne

- CMI9739A/CMI9761A (pour v. 7.0)
- Conforme aux spécifications du codec AC'97.
- Supporte 6 canaux, stereo microphone.
- Interface AC97 2.2/ Interface AC97 2.3.

Périphériques Internes

a. Côté arrière

- 1 ports série, 1 ports VGA.
- 1 port parallèle (mode SPP/EPP/ECP).
- Ports audio en position verticale.
- 1 port RJ-45 LAN.
- Souris PS/2 et clavier PS/2.
- 4 ports USB2.0.

b. Côté frontal :

- 1 port disquette prenant en charge 2 FDD avec 360K, 720K, 1.2M, 1.44M et 2,88Mo.
- 4 ports USB2.0.

BIOS

- AWARD legal Bios.
- Supporte APM1.2.
- Supporte ACPI
- Supporte la Fonction USB.

Système d'Exploitation

- Offre les meilleures performances pour Windows 98 SE, Windows 2000, Windows Me, Windows XP, SCO UNIX etc.
- Supporte Waspeeder™, 9th Touch™, FLASHER™, StudioFun™ (optionnel).

Dimensions

- Facteur de Forme ATX: 24.4 cm X 24.4 cm (l X L)
- Facteur de Forme ATX: 24.4 cm X 22.7 cm (l X L) (pour v. 7.0)

Contenu de l'Emballage

- Câble de Disque Dur X1
- Câble de Lecteur de Disquette X1
- Manuel d'utilisation X1
- CD de Sollicitation StudioFun! X1 (Optionnel)
- Câble USB X1 (Optionnel)
- Panneau d'E/S Arrière pour Boîtier Flex X1 (Optionnel)
- CD de Pilote Complet X1
- Câble S/PDIF X1 (optionnel)
- Câble ATA Série X1 (optionnel)
- Câble de Commutateur d'Alimentation ATA Série X1 (optionnel)

WarpSpeeder



Introduction

[WarpSpeeder™], a new powerful control utility, features three user-friendly functions including Overclock Manager, Overvoltage Manager, and Hardware Monitor.

With the Overclock Manager, users can easily adjust the frequency they prefer or they can get the best CPU performance with just one click. The Overvoltage Manager, on the other hand, helps to power up CPU core voltage and Memory voltage. The cool Hardware Monitor smartly indicates the temperatures, voltage and CPU fan speed as well as the chipset information. Also, in the About panel, you can get detail descriptions about BIOS model and chipsets. In addition, the frequency status of CPU, memory, AGP and PCI along with the CPU speed are synchronically shown on our main panel.

Moreover, to protect users' computer systems if the setting is not appropriate when testing and results in system fail or hang, [WarpSpeeder™] technology assures the system stability by automatically rebooting the computer and then restart to a speed that is either the original system speed or a suitable one.

System Requirement

OS Support: Windows 98 SE, Windows Me, Windows 2000, Windows XP

DirectX: DirectX 8.1 or above. (The Windows XP operating system includes DirectX 8.1. If you use Windows XP, you do not need to install DirectX 8.1.)

Installation

1. Execute the setup execution file, and then the following dialog will pop up. Please click “Next” button and follow the default procedure to install.



2. When you see the following dialog in setup procedure, it means setup is completed. If the “Launch the WarpSpeeder Tray Utility” checkbox is checked, the Tray Icon utility and [WarpSpeeder™] utility will be automatically and immediately launched after you click “Finish” button.

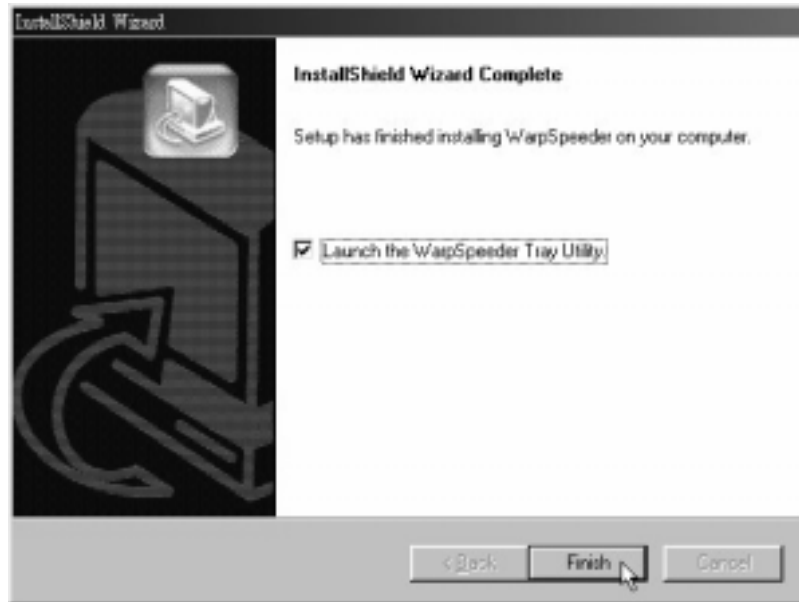

Usage

The following figures are just only for reference, the screen printal in this user manual will change according to your motherboard on hand.

[WarpSpeeder™] includes 1 tray icon and 5 panels:

1. Tray Icon:

Whenever the Tray Icon utility is launched, it will display a little tray icon on the right side of Windows Taskbar.

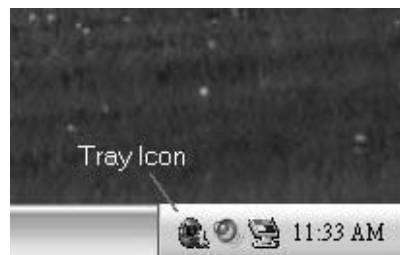

This utility is responsible for conveniently invoking [WarpSpeeder™] Utility. You can use the mouse by clicking the left button in order to invoke [WarpSpeeder™] directly from the little tray icon or you can right-click the little tray icon to pop up a popup menu as following figure. The “Launch Utility” item in the popup menu has the same function as mouse left-click on tray icon and “Exit” item will close Tray Icon utility if selected.



2. Main Panel

If you click the tray icon, [WarpSpeeder™] utility will be invoked. Please refer to the following figure; the utility's first window you will see is Main Panel.

Main Panel contains features as follows:

- a. Display the CPU Speed, CPU external clock, Memory clock, AGP clock, and PCI clock information.
- b. Contains About, Voltage, Overclock, and Hardware Monitor Buttons for invoking respective panels.
- c. With a user-friendly Status Animation, it can represent 3 overclock percentage stages:

Man walking => overclock percentage from 100% ~ 110 %

Panther running => overclock percentage from 110% ~ 120%

Car racing => overclock percentage from 120% ~ above

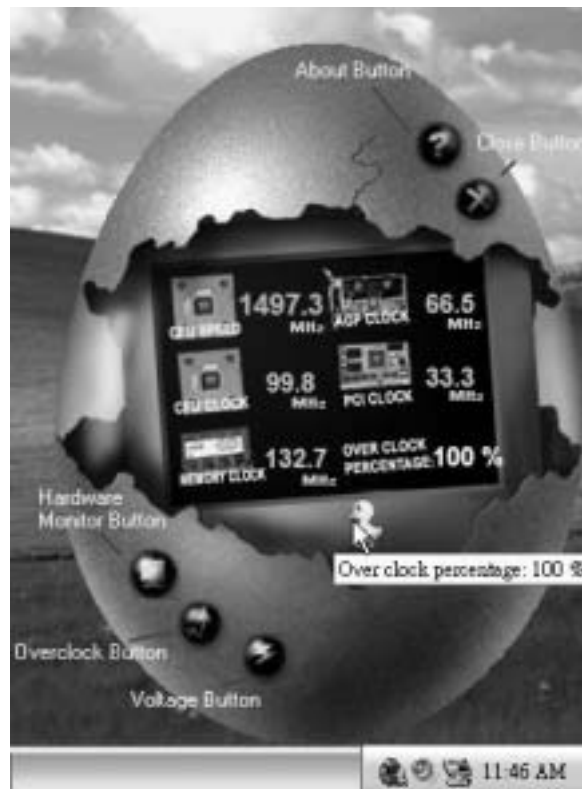

3. Voltage Panel

Click the Voltage button in Main Panel, the button will be highlighted and the Voltage Panel will slide out to up as the following figure.

In this panel, you can decide to increase CPU core voltage and Memory voltage or not. The default setting is "No". If you want to get the best performance of overclocking, we recommend you click the option "Yes".



4. Overclock Panel

Click the Overclock button in Main Panel, the button will be highlighted and the Overclock Panel will slide out to left as the following figure.



Overclock Panel contains the these features:

- a. “-3MHz button”, “-1MHz button”, “+1MHz button”, and “+3MHz button”: provide user the ability to do real-time overclock adjustment.

Warning: Manually overclock is potentially dangerous, especially when the overcbocking percentage is over 110 %. We strongly recommend you verify every speed you overclock by click the Verify button. Or, you can just click Auto overclock button and let [WarpSpeeder™] automatically gets the best result for you.

- b. “Recovery Dialog button”: Pop up the following dialog. Let user select a restoring way if system need to do af ail-safe reboot.

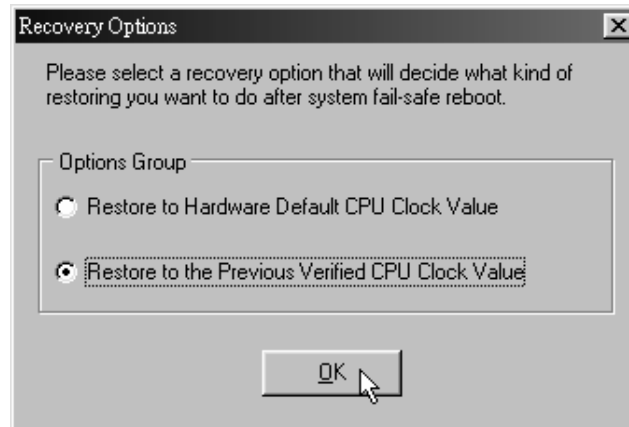

- d. "Auto-overclock button": User can click this button and [WarpSpeeder™] will set the best and stable performance and frequency automatically. [WarpSpeeder™] utility will execute a series of testing until system fail. Then system will do fail-safe reboot by using Watchdog function. After reboot, the [WarpSpeeder™] utility will restore to the hardware default setting or load the verified best and stable frequency according to the Recovery Dialog's setting.
- e. "Verify button": User can click this button and [WarpSpeeder™] will proceed a testing for current frequency. If the testing is ok, then the current frequency will be saved into system registry. If the testing fail, system will do a fail-safe rebooting. After reboot, the [WarpSpeeder™] utility will restore to the hardware default setting or load the verified best and stable frequency according to the Recovery Dialog's setting.

Note: Because the testing programs, invoked in Auto-overclock and Verify, include DirectDraw, Direct3D and DirectShow tests, the DirectX 8.1 or newer runtime library is required. And please make sure your display card's color depth is High color (16 bit) or True color (24/32 bit) that is required for Direct3D rendering.

5. Hardware Monitor Panel

Click the Hardware Monitor button in Main Panel, the button will be highlighted and the Hardware Monitor panel will slide out to left as the following figure.

In this panel, you can get the real-time status information of your system. The information will be refreshed every 1 second.



6. About Panel

Click the About button in Main Panel, the button will be highlighted and the About Panel will slide out to up as the following figure.

In this panel, you can get model name and detail information in hints of all the chipset that are related to overclocking. You can also get the mainboard's BIOS model and the Version number of [WarpSpeeder™] utility.

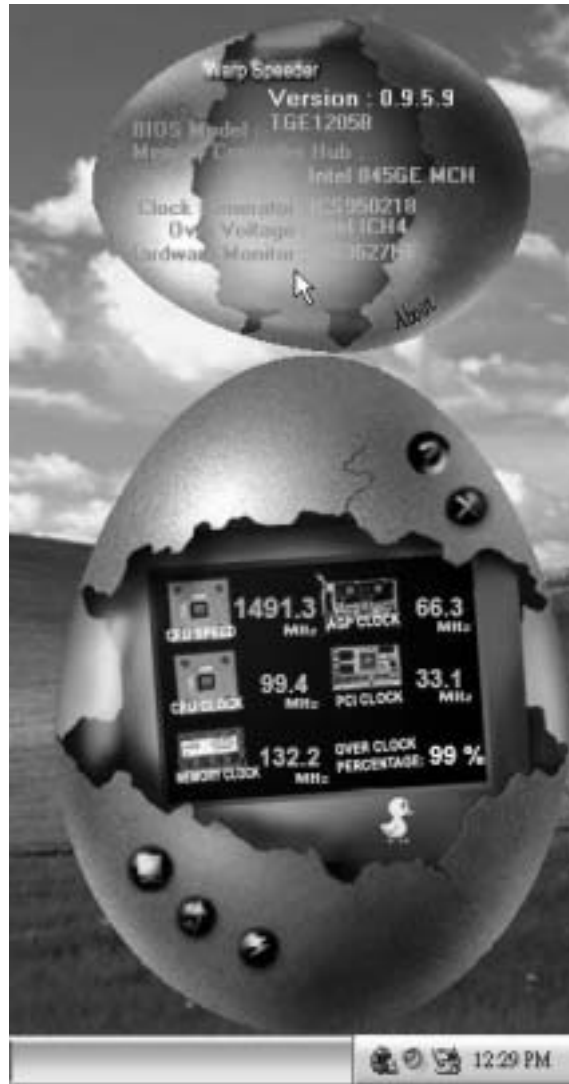

Note: Because the overclock, overvdtage, and hardware monitor features are controlled by several separate chipset, [WarpSpeeder™] divide these features to separate panels. If one chipset is not on board, the correlative button in Main panel will be disabled, but will not interfere other panels functions. This property can make [WarpSpeeder™] utility more robust.

Trouble Shooting

PROBABLE	SOLUTION
No power to the system at all. Power light don't illuminate, fan inside power supply does not turn on. Indicator light on keyboard does not turn on.	<ul style="list-style-type: none"> * Make sure power cable is securely plugged in. * Replace cable. * Contact technical support.
System inoperative. Keyboard lights are on, power indicator lights are lit, hard drive is spinning.	<ul style="list-style-type: none"> * Using even pressure on both ends of the DIMM, press down firmly until the module snaps into place.
System does not boot from hard disk drive, can be booted from CD-ROM drive.	<ul style="list-style-type: none"> * Check cable running from disk to disk controller board. Make sure both ends are securely plugged in; check the drive type in the standard CMOS setup. * Backing up the hard drive is extremely important. All hard disks are capable of breaking down at any time.
System only boots from CD-ROM. Hard disk can be read and applications can be used but booting from hard disk is impossible.	<ul style="list-style-type: none"> * Back up data and applications files. Reformat the hard drive. Re-install applications and data using backup disks.
Screen message says "Invalid Configuration" or "CMOS Failure."	<ul style="list-style-type: none"> * Review system's equipment. Make sure correct information is in setup.
Cannot boot system after installing second hard drive.	<ul style="list-style-type: none"> * Set master/slave jumpers correctly. * Run SETUP program and select correct drive types. Call drive manufacturers for compatibility with other drives.

Solución de Problemas

CAUSA PROBABLE	SOLUCIÓN
No hay corriente en el sistema. La luz de corriente no ilumina, ventilador dentro de la fuente de alimentación apagada. Indicador de luz del teclado apagado.	<ul style="list-style-type: none"> * Asegúrese que el cable de transmisión esté seguramente enchufado. * Reemplace el cable. * Contacte ayuda técnica.

CAUSA PROBABLE	SOLUCIÓN
Sistema inoperativo. Luz del teclado encendido, luz de indicador de corriente iluminado, disco rígido está girando.	<ul style="list-style-type: none"> * Presione los dos extremos del DIMM, presione para abajo firmemente hasta que el módulo encaje en el lugar.

CAUSA PROBABLE	SOLUCIÓN
Sistema no arranca desde el disco rígido, puede ser arrancado desde el CD-ROM drive.	<ul style="list-style-type: none"> * Controle el cable de ejecución desde el disco hasta el disco del controlador. Asegúrese de que ambos lados estén enchufados con seguridad; controle el tipo de disco en la configuración estándar CMOS. * Copiando el disco rígido es extremadamente importante. Todos los discos rígidos son capaces de dañarse en cualquier momento.

CAUSA PROBABLE	SOLUCIÓN
Sistema solamente arranca desde el CD-ROM. Disco rígido puede leer y aplicaciones pueden ser usados pero el arranque desde el disco rígido es imposible.	<ul style="list-style-type: none"> * Copie datos y documentos de aplicación. Vuelva a formatear el disco rígido. Vuelva a instalar las aplicaciones y datos usando el disco de copiado.

CAUSA PROBABLE	SOLUCIÓN
Mensaje de pantalla "Invalid Configuration" o "CMOS Failure"	<ul style="list-style-type: none"> * Revise el equipo del sistema. Asegúrese de que la información configurada sea correcta.

CAUSA PROBABLE	SOLUCIÓN
No puede arrancar después de instalar el segundo disco rígido.	<ul style="list-style-type: none"> * Fije correctamente el puente master/esclavo. * Ejecute el programa SETUP y seleccione el tipo de disco correcto. Llame a una manufacturación del disco para compatibilidad con otros discos.

Problemlösung

MÖGLICHE URSACHE	LÖSUNG
Das System hat keine Spannungsversorgung. Die Stromanzeige leuchtet nicht, der Lüfter im Inneren der Stromversorgung wird nicht eingeschaltet. Tastaturleuchten sind nicht an.	<ul style="list-style-type: none"> * Versichern Sie sich, dass das Stromkabel richtig angebracht ist * Ersetzen Sie das Stromkabel * Wenden Sie sich an Ihre Kundendienststelle

MÖGLICHE URSACHE	LÖSUNG
Das System funktioniert nicht. Die Tastaturleuchten sind an, die Stromanzeige leuchtet, die Festplatte dreht sich.	<ul style="list-style-type: none"> * Drücken Sie das DIMM-Modul bei gleichem Druck an beide Seiten, bis es einrastet.

MÖGLICHE URSACHE	LÖSUNG
Das System wird von der Festplatte nicht hochgefahren, vom CD-ROM-Treiber aber ja.	<ul style="list-style-type: none"> * Überprüfen Sie das Kabel zwischen Festplatte und Festplatten-Controller. Versichern Sie sich, dass beide Enden richtig angebracht sind; überprüfen Sie den Laufwerktyp in der standardmäßigen CMOS-Einrichtung. * Ein Backup der Festplatte ist sehr wichtig. Alle Festplatten können irgendwann beschädigt werden

MÖGLICHE URSACHE	LÖSUNG
Das System wird nur von der CD-ROM hochgefahren. Die Festplatte wird gelesen und die Anwendungen sind funktionsfähig, aber es ist nicht möglich, das System von der Festplatte zu starten	<ul style="list-style-type: none"> * Machen Sie eine Sicherungskopie von allen Daten und Anwendungsdateien. Formatieren Sie die Festplatte und installieren Sie die Anwendungen und Daten mit Hilfe von Backup-Disks

MÖGLICHE URSACHE	LÖSUNG
Auf dem Bildschirm erscheint die Meldung "Ungültige Konfiguration" oder "CMOS Fehler."	<ul style="list-style-type: none"> * Überprüfen Sie die Systemkomponenten und versichern Sie sich, dass diese richtig eingerichtet sind

MÖGLICHE URSACHE	LÖSUNG
Das System kann nach der Installation einer zweiten Festplatte nicht hochgefahren werden.	<ul style="list-style-type: none"> * Setzen Sie die Master/Slave-Jumper richtig ein. * Führen Sie das SETUP-Programm aus und wählen Sie die richtigen Laufwerktypen. Wenden Sie sich an den Laufwerkhersteller, um die Kompatibilität mit anderen Laufwerken zu überprüfen



02/09/2004



P4TSV BIOS Setup

BIOS Setup.....	1
1 Main Menu.....	3
2 Standard CMOS Features	6
3 Advanced BIOS Features.....	9
4 Advanced Chipset Features.....	13
5 Integrated Peripherals	16
6 Power Management Setup	21
7 PnP/PCI Configurations	25
8 PC Health Status	27
9 Frequency Control	29

P4TSV BIOS Setup

BIOS Setup

Introduction

This manual discussed Award™ Setup program built into the ROM BIOS. The Setup program allows users to modify the basic system configuration. This special information is then stored in battery-backed RAM so that it retains the Setup information when the power is turned off.

The Award BIOS™ installed in your computer system's ROM (Read Only Memory) is a custom version of an industry standard BIOS. This means that it supports Intel Pentium® 4 processor input/output system. The BIOS provides critical low-level support for standard devices such as disk drives and serial and parallel ports.

Adding important has customized the Award BIOS™, but nonstandard, features such as virus and password protection as well as special support for detailed fine-tuning of the chipset controlling the entire system.

The rest of this manual is intended to guide you through the process of configuring your system using Setup.

Plug and Play Support

These AWARD BIOS supports the Plug and Play Version 1.0A specification. ESCD (Extended System Configuration Data) write is supported.

EPA Green PC Support

This AWARD BIOS supports Version 1.03 of the EPA Green PC specification.

APM Support

These AWARD BIOS supports Version 1.1&1.2 of the Advanced Power Management (APM) specification. Power management features are implemented via the System Management Interrupt (SMI). Sleep and Suspend power management modes are supported. This AWARD BIOS can manage power to the hard disk drives and video monitors.

ACPI Support

Award ACPI BIOS support Version 1.0 of Advanced Configuration and Power interface specification (ACPI). It provides ASL code for power management and device configuration capabilities as defined in the ACPI specification, developed by Microsoft, Intel and Toshiba.

P4TSV BIOS Setup

PCI Bus Support

This AWARD BIOS also supports Version 2.1 of the Intel PCI (Peripheral Component Interconnect) local bus specification.

DRAM Support

DDR DRAM (Double Data Rate Synchronous DRAM) are supported.

Supported CPUs

This AWARD BIOS supports the Intel Pentium[®] 4 CPU.

Using Setup

In general, you use the arrow keys to highlight items, press <Enter> to select, use the <PgUp> and <PgDn> keys to change entries, press <F1> for help and press <Esc> to quit. The following table provides more detail about how to navigate in the Setup program by using the keyboard.

Keystroke	Function
Up arrow	Move to previous item
Down arrow	Move to next item
Left arrow	Move to the item on the left (menu bar)
Right arrow	Move to the item on the right (menu bar)
Move Enter	Move to the item you desired
PgUp key	Increase the numeric value or make changes
PgDn key	Decrease the numeric value or make changes
+ Key	Increase the numeric value or make changes
- Key	Decrease the numeric value or make changes
Esc key	Main Menu – Quit and not save changes into CMOS Status Page Setup Menu and Option Page Setup Menu – Exit Current page and return to Main Menu
F1 key	General help on Setup navigation keys
F5 key	Load previous values from CMOS
F7 key	Load the optimized defaults
F10 key	Save all the CMOS changes and exit

P4TSV BIOS Setup

1 Main Menu

Once you enter Award BIOS™ CMOS Setup Utility, the Main Menu will appear on the screen. The Main Menu allows you to select from several setup functions. Use the arrow keys to select among the items and press <Enter> to accept and enter the sub-menu.

⚠WARNING

The information about BIOS defaults on this manual (**Figure 1,2,3,4,5,6,7,8,9**) is just only for reference, please refer to the BIOS installed on board, for update information.

■ **Figure 1. Main Menu**

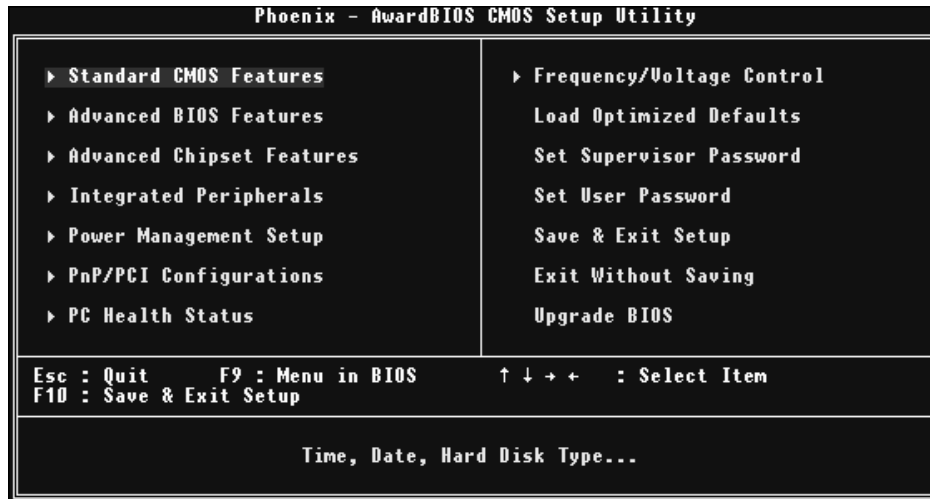

Standard CMOS Features

This submenu contains industry standard configurable options.

Advanced BIOS Features

This submenu allows you to configure enhanced features of the BIOS.

Advanced Chipset Features

This submenu allows you to configure special chipset features.

P4TSV BIOS Setup

Integrated Peripherals

This submenu allows you to configure certain IDE hard drive options and Programmed Input/ Output features.

Power Management Setup

This submenu allows you to configure the power management features.

PnP/PCI Configurations

This submenu allows you to configure certain “Plug and Play” and PCI options.

PC Health Status

This submenu allows you to monitor the hardware of your system.

Frequency Control

This submenu allows you to change CPU Vcore Voltage and CPU/PCI clock. **(However, this function is strongly recommended not to use. Not properly change the voltage and clock may cause CPU or M/B damage!)**

Load Optimized Defaults

This selection allows you to reload the BIOS when the system is having problems particularly with the boot sequence. These configurations are factory settings optimized for this system. A confirmation message will be displayed before defaults are set.



Load Optimized Defaults (Y/N)? N

Set Supervisor Password

Setting the supervisor password will prohibit everyone except the supervisor from making changes using the CMOS Setup Utility. You will be prompted with to enter a password.



Enter Password:

Set User Password

If the Supervisor Password is not set, then the User Password will function in the same way as the Supervisor Password. If the Supervisor Password is set and the User Password is set, the “User” will only be able to view configurations but will not be able to change them.



Enter Password:

P4TSV BIOS Setup

Save & Exit Setup

Save all configuration changes to CMOS(memory) and exit setup. Confirmation message will be displayed before proceeding

```
SAVE to CMOS and EXIT (Y/N)? Y
```

Exit Without Saving

Abandon all changes made during the current session and exit setup. Confirmation message will be displayed before proceeding

```
Quit Without Saving (Y/N)? N
```

Upgrade BIOS

This submenu allows you to upgrade bios.

```
BIOS UPDATE UTILITY (Y/N)? N
```

P4TSV BIOS Setup

2 Standard CMOS Features

The items in Standard CMOS Setup Menu are divided into 10 categories. Each category includes no, one or more than one setup items. Use the arrow keys to highlight the item and then use the <PgUp> or <PgDn> keys to select the value you want in each item.

■ **Figure 2. Standard CMOS Setup**

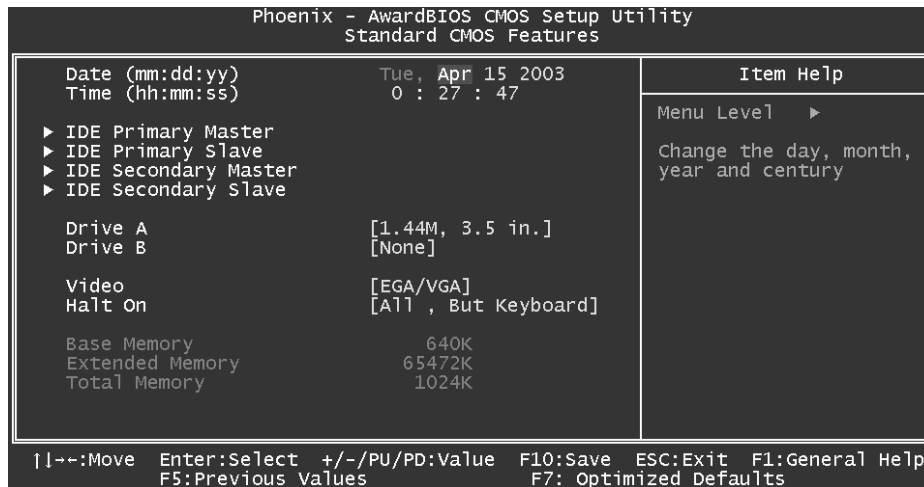

P4TSV BIOS Setup

Main Menu Selections

This table shows the selections that you can make on the Main Menu.

Item	Options	Description
Date	mm : dd : yy	Set the system date. Note that the 'Day' automatically changes when you set the date.
Time	hh : mm : ss	Set the system internal clock.
IDE Primary Master	Options are in its sub menu.	Press <Enter> to enter the sub menu of detailed options
IDE Primary Slave	Options are in its sub menu.	Press <Enter> to enter the sub menu of detailed options.
IDE Secondary Master	Options are in its sub menu.	Press <Enter> to enter the sub menu of detailed options.
IDE Secondary Slave	Options are in its sub menu.	Press <Enter> to enter the sub menu of detailed options.
Drive A Drive B	360K, 5.25 in 1.2M, 5.25 in 720K, 3.5 in 1.44M, 3.5 in 2.88M, 3.5 in None	Select the type of floppy disk drive installed in your system.
Video	EGA/VGA CGA 40 CGA 80 MONO	Select the default video device.

P4TSV BIOS Setup

Item	Options	Description
Halt On	All Errors No Errors All, but Keyboard All, but Diskette All, but Disk/ Key	Select the situation in which you want the BIOS to stop the POST process and notify you.
Base Memory	N/A	Displays the amount of conventional memory detected during boot up.
Extended Memory	N/A	Displays the amount of extended memory detected during boot up.
Total Memory	N/A	Displays the total memory available in the system.

P4TSV BIOS Setup

3 Advanced BIOS Features

■ Figure 3. Advanced BIOS Setup

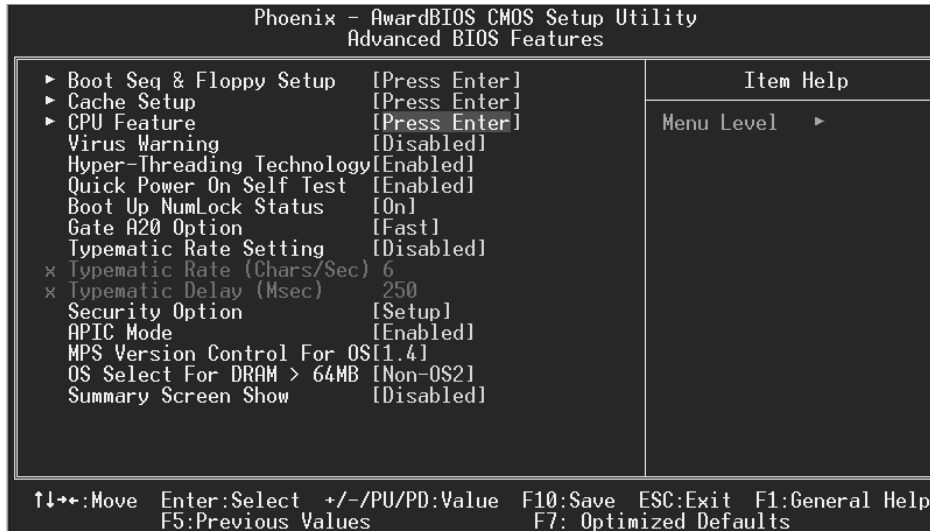

Boot Seq & Floppy Setup

First/ Second/ Third/ Boot Other Device

These BIOS attempt to load the operating system from the device in the sequence selected in these items.

The Choices: Floppy, LS120, HDD-0, SCSI, CDROM, HDD-1, HDD-2, HDD-3, ZIP 100, LAN, HPT370, Disabled, Enabled.

Swap Floppy Drive

For systems with two floppy drives, this option allows you to swap logical drive assignments.

The Choices: Disabled (default), Enabled.

Boot Up Floppy Seek

Enabling this option will test the floppy drives to determine if they have 40 or 80 tracks. Disabling this option reduces the time it takes to boot-up.

The Choices: Disabled, Enabled (default).

Report NO FDD for Win95

The Choices: NO (default).

P4TSV BIOS Setup

Cache Setup

CPU L1&L2 Cache

Depending on the CPU/chipset in use, you may be able to increase memory access time with this option.

Enabled (default) Enable cache.
Disabled Disable cache.

CPU Feature

Thermal Management

Allows you to choose the thermal management of your monitor.

The Choices: Thermal Monitor 1 (default), Thermal Monitor2.

TM2 Bus Ratio

Represents the frequency. Bus ratio of the throttled performance state that will be initiated when the on-die sensor goes from not hot to hot.

The Choices: 0X (default).

TM2 Bus VID

Represents the voltage of the throttled performance state that will be initiated when the on-die sensor goes from not hot to hot.

The Choices: 0.8375 (default).

Limit CPU ID Max Val

Set limit CPU ID maximum value to 3, it should be disabled for WinXP.

The Choices: Disabled (default), Enabled.

Virus Warning

This option allows you to choose the Virus Warning feature that is used to protect the IDE Hard Disk boot sector. If this function is enabled and an attempt is made to write to the boot sector, BIOS will display a warning message on the screen and sound an alarm beep.

Enabled Virus protection is activated.
Disabled (default) Virus protection is disabled.

CPU Hyper-Threading Technology

This option allows you to enable or disabled CPU Hyper-Threading. Enabled for Windows XP and Linux 2.4.x (OS optimized for Hyper Threading Technology. Disabled for other OS (OS not optimized for Hyper Threading Technology.

The Choices: Enabled (Default), Disabled.

Quick Power On Self Test

Enabling this option will cause an abridged version of the Power On Self-Test (POST) to execute after you power up the computer.

Disabled Normal POST.
Enabled (default) Enable quick POST.

P4TSV BIOS Setup

Boot Up NumLock Status

Selects the NumLock. State after power on.

- | | |
|---------------------|------------------------|
| On (default) | Numpad is number keys. |
| Off | Numpad is arrow keys. |

Gate A20 Option

Select if chipset or keyboard controller should control Gate A20.

- | | |
|-----------------------|---|
| Normal | A pin in the keyboard controller controls Gate A20. |
| Fast (default) | Lets chipset control Gate A20. |

Typematic Rate Setting

When a key is held down, the keystroke will repeat at a rate determined by the keyboard controller. When enabled, the typematic rate and typematic delay can be configured.

The Choices: Disabled (default), Enabled.

Typematic Rate (Chars/Sec)

Sets the rate at which a keystroke is repeated when you hold the key down.

The Choices: 6 (default), 8,10,12,15,20,24,30.

Typematic Delay (Msec)

Sets the delay time after the key is held down before it begins to repeat the keystroke.

The Choices: 250 (default), 500, 750, 1000.

Security Option

This option will enable only individuals with passwords to bring the system online and/or to use the CMOS Setup Utility.

- | | |
|------------------------|---|
| System | A password is required for the system to boot and is also required to access the Setup Utility. |
| Setup (default) | A password is required to access the Setup Utility only. |

This will only apply if passwords are set from the Setup main menu.

APIC Mode

Selecting Enabled enables ACPI device mode reporting from the BIOS to the operating system.

The Choices: Enabled (default), Disabled.

MPS Version Control For OS

The BIOS supports version 1.1 and 1.4 of the Intel multiprocessor specification.

Select version supported by the operation system running on this computer.

The Choices: 1.4 (default), 1.1.

P4TSV BIOS Setup

OS Select For DRAM > 64MB

A choice other than Non-OS2 is only used for OS2 systems with memory exceeding 64MB.

The Choices: Non-OS2 (default), OS2.

Summary Screen Show

This item allows you to enable/disable the summary screen. Summary screen means system configuration and PCI device listing.

The choices: Enabled, Disabled (default).

P4TSV BIOS Setup

4 Advanced Chipset Features

This submenu allows you to configure the specific features of the chipset installed on your system. This chipset manage bus speeds and access to system memory resources, such as DRAM. It also coordinates communications with the PCI bus. The default settings that came with your system have been optimized and therefore should not be changed unless you are suspicious that the settings have been changed incorrectly.

■ Figure 4. Advanced Chipset Setup



DRAM Timing Selectable

When synchronous DRAM is installed, the number of clock cycles of CAS latency depends on the DRAM timing.

The Choices: By SPD (default), Manual.

CAS Latency Time

When synchronous DRAM is installed, the number of clock cycles of CAS latency depends on the DRAM timing.

The Choices: 1.5, 2(default), 2.5, 3.

Active to Precharge Delay

This item controls the number of DRAM clocks to activate the precharge delay.

The Choices: 8 (default), 7, 6, 5.

P4TSV BIOS Setup

DRAM RAS# to CAS# Delay

This field let you insert a timing delay between the CAS and RAS strobe signals, used when DRAM is written to, read from, or refreshed. Fast gives faster performance; and slow gives more stable performance. This field applies only when synchronous DRAM is installed in the system.

The Choices: 4 (default), 3, 2.

DRAM RAS# Precharge

If an insufficient number of cycle is allowed for RAS to accumulate its charge before DRAM refresh, the refresh may be incomplete, and the DRAM may fail to retain data. Fast gives faster performance; and Slow gives more stable performance. This field applies only when synchronous DRAM is installed in the system.

The Choices: 4 (default), 3, 2.

Memory Frequency For

This item allows you to select the Memory Frequency.

The Choices: Auto (default), DDR266, DDR300, DDR400.

System BIOS Cacheable

Selecting Enabled allows you caching of the system BIOS ROM at F0000h~FFFFh, resulting a better system performance. However, if any program writes to this memory area, a system error may result.

The Choices: Enabled (default), Disabled.

Video BIOS Cacheable

Select Enabled allows caching of the video BIOS, resulting a better system performance. However, if any program writes to this memory area, a system error may result.

The Choices: Disabled, Enabled (default).

Memory Hole At 15M-16M

You can reserve this area of system memory for ISA adapter ROM. When this area is reserved it cannot be cached. The user information of peripherals that need to use this area of system memory usually2 discussed their memory requirements.

The Choices: Disabled (default), Enabled.

Delay Prior to Thermal

Set this item to enable the CPU Thermal function to engage after the specified time.

The Choices: 4, 8, 16 (default), 32.

AGP Aperture Size (MB)

Select the size of the Accelerated Graphics Port (AGP) aperture. The aperture is a portion of the PCI memory address range dedicated for graphics memory address space. Host

P4TSV BIOS Setup

cycles that hit the aperture range are forwarded to the AGP without any translation.

The Choices: 64, 4, 8, 16, 32, **128**(default), 256.

Init Display First

This item allows you to decide to active whether PCI Slot or on-chip VGA first.

The Choices: **Onboard/ AGP** (default), PCI Slot.

On-Chip VGA

This item allows you to enabled or disabled on-chip VGA.

The Choices: **Enabled** (default), Disabled.

On-Chip Frame Buffer Size

This item allows you to choose the on-chip frame buffer size.

The Choices: **16MB** (default), 8MB, 1MB.

Boot Display

This item allows you to choose the display booting

The Choices: **Auto** (default), CRT, TV, EFP.

P4TSV BIOS Setup

5 Integrated Peripherals

■ Figure 5. Integrated Peripherals

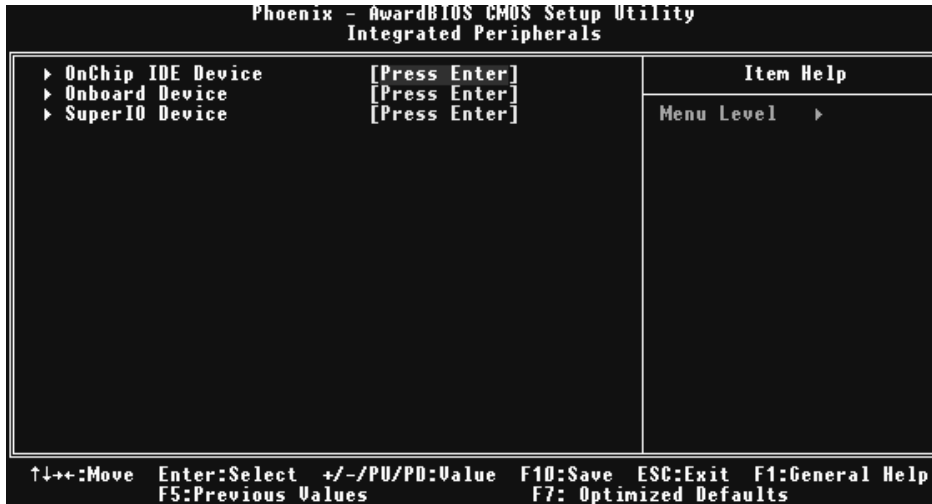

Onboard IDE Device

Press Enter to configure the onboard IDE Controllers.

IDE HDD Block Mode

Block mode is also called block transfer, multiple commands, or multiple sector read / write. If your IDE hard drive supports block mode (most new drives do), select Enabled for automatic detection of the optimal number of block mode (most new drives do), select Enabled for automatic detection of the optimal number of block read / write per sector where the drive can support.

The Choices: Enabled (default), Disabled.

IDE DMA Transfer Access

This item allows you to enable or disable the IDE transfer access.

The Choices: Enabled (default), Disabled.

On-Chip Primary/ Secondary PCI IDE

This item allows you to enable or disable the primary/ secondary IDE Channel.

The Choices: Enabled (Default), Disabled.

Primary / Secondary /Master / Slave PIO

The IDE PIO (Programmed Input / Output) fields let you set a PIO mode (0-4) for each of the IDE devices that the onboard IDE interface supports. Modes 0 to 4

P4TSV BIOS Setup

will increased performance progressively. In Auto mode, the system automatically determines the best mode for each device.

The Choices: **Auto** (default), Mode0, Mode1, Mode2, Mode3, Mode4.

Primary / Secondary /Master / Slave UDMA

Ultra DMA/100 functionality can be implemented if it is supported by the IDE hard drives in your system. As well, your operating environment requires a DMA driver (Windows 95 OSR2 or a third party IDE bus master driver). If your hard drive and your system software both support Ultra DMA/100, select Auto to enable BIOS support.

The Choices: **Auto** (default), Disabled.

On-Chip Serial SATA

This item allows you to choose:

Disabled: disabled SATA Controller.

Auto: auto arrange by BIOS.

Combined Mode: PATA and SATA are combined max of 2 IDE drivers in each channel.

Enhanced Mode: enabled both SATA and PATA max of 6 IDE drivers are supported.

SATA Only: SATA is operating in legacy mode.

The Choices: **Default** (default), Auto, Combined Mode, Enhanced Mode, SATA only.

Serial ATA Port0 Mode

The Choices: **Primary Master** (default).

Serial ATA Port1 Mode

The Choices: **Primary Master** (default).

Onboard Device

Press Enter to configure the onboard Device.

USB Controller

Select Enabled if your system contains a Universal Serial Bus (USB) controller and you have USB peripherals.

The Choices: **Enabled** (default), Disabled

USB 2.0 Controller

This entry is to enabled/ disabled EHCI controller only. This BIOS itself may/ may not have high speed USB support. If the BIOS has high speed USB support built in, the support will automatically turn on, when high speed device were attached.

The Choices: **enabled**(default).

P4TSV BIOS Setup

USB Keyboard Support

This item allows you to enable or disable the USB Keyboard Legacy Support.

Enabled Enable USB Keyboard Support.
Disabled (default) Disable USB Keyboard Support.

USB Mouse Support

This item allows you to enable or disable the USB Mouse Legacy Support.

Enabled Enable USB Mouse Support.
Disabled (default) Disable USB Mouse Support.

AC97 Audio/ Modem

This item allows you to decide to enable/ disable to support AC97 Audio/Modem.

The Choices: Auto (default), Disabled.

Onboard PCI LAN

This item allows you to enable or disable the Onboard PCI LAN.

The Choices: Auto (default), Disabled.

Onboard LAN Boot ROM

This item allows you to enable or disable the Onboard LAN Boot ROM.

The Choices: Enabled (default), Disabled.

Super IO Device

Press Enter to configure the Super I/O Device.

Power On Function

This item allows you to choose the power on function.

The Choices: Button (default), Password, Hot Key, Mouse Left, Mouse Right, Any Key, Keyboard 98.

KB Power on Password

Input password and press Enter to set the Keyboard power on password .

HOT Key power ON

Input password and press Enter to set the Keyboard power on password .

The Choices: Ctrl-F1(default) , Ctrl-F2 , Ctrl-F3 , Ctrl-F4 , Ctrl-F5, Ctrl-F6 , Ctrl-F7 , Ctrl-F8 , Ctrl-F9, Ctrl-F10 , Ctrl-F11 , Ctrl-F12 .

Onboard FDC Controller

Select Enabled if your system has a floppy disk controller (FDC) installed on the system board and you wish to use it. If install and FDC or the system has no floppy drive, select Disabled in this field.

The Choices: Enabled (default), Disabled.

Onboard Serial Port 1

Select an address and corresponding interrupt for the first and second serial ports.

P4TSV BIOS Setup

The Choices: 3F8/IRQ4 (default), Disabled, Auto, 2F8/IRQ3, 3E8/IRQ4, 2E8/IRQ3.

Onboard Serial Port 2

Select an address and corresponding interrupt for the first and second serial ports

The Choices: 2F8/IRQ3, **Disabled** (default), Auto, 3F8/IRQ4, 3E8/IRQ4, 2E8/IRQ3.

UART Mode Select

This item allows you to determine which Infrared (IR) function of onboard I/O chip.

The Choices: Normal, ASKIR, **IrDA** (default), SCR .

UR2 Duplex Mode

Select the value required by the IR device connected to the IR port. Full-duplex mode permits simultaneous two-direction transmission. Half-duplex mode permits transmission in one direction only at a time.

The Choices: **Half** (default), Full.

Onboard Parallel Port

This item allows you to determine access onboard parallel port controller with which I/O Address.

The Choices: 378/IRQ7 (default), 278/IRQ5, 3BC/IRQ7, Disabled.

Parallel Port Mode

The default value is SPP.

SPP (default)	Using Parallel port as Standard Printer Port.
EPP	Using Parallel port as Enhanced Parallel Port.
ECP	Using Parallel port as Extended Capabilities Port.
ECP+EPP	Using Parallel port as ECP & EPP mode.

ECP Mode Use DMA

Select a DMA Channel for the port.

The Choices: **3** (default), 1.

Power After Power Fail

This setting specifies whether your system will reboot after a power fail or interrupts occurs.

Off	Leaves the computer in the power off state.
On	Reboots the computer.
Former-Sts	Restores the system to the status before power failure or interrupt occurs.

The Choices: **Off** (default), On, Former-Sts.

Game Port Address

Game Port I/O Address.

The Choices: **201** (default), 209, Disabled.

P4TSV BIOS Setup

Midi Port Address

Midi Port Base I/O Address.

The Choices: 330 (default), 300, Disabled.

Midi Port IRQ

This determines the IRQ in which the Midi Port can use.

The Choices: 10 (default), 5.

P4TSV BIOS Setup

6 Power Management Setup

The Power Management Setup Menu allows you to configure your system to utilize energy conservation and power up/power down features.

■ Figure 6. Power Management Setup

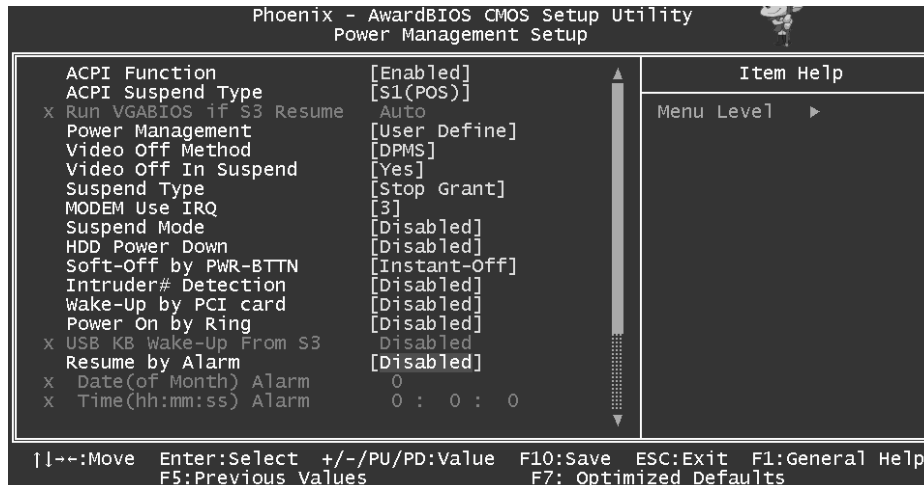

ACPI Function

This item displays the status of the Advanced Configuration and Power Management (ACPI).

The Choices: Enabled (default), Disabled.

ACPI Suspend Type

The item allows you to select the suspend type under the ACPI operating system.

The Choices: S1 (POS) (default) Power on Suspend
S3 (STR) Suspend to RAM
S1 & S3 POS+STR

Run VGABIOS if S3 Resume

Choosing Enabled will make BIOS run VGA BIOS to initialize the VGA card when system wakes up from S3 state. The system time is shortened if you disable the function, but system will need AGP driver to initialize the card. So, if the AGP driver of the VGA card does not support the initialization feature, the display may work abnormally or not function after S3.

The Choices: Auto (default), Yes, No.

P4TSV BIOS Setup

Power Management

This category allows you to select the type (or degree) of power saving and is directly related to the following modes:

- 1.HDD Power Down.
- 2.Doze Mode.
- 3.Suspend Mode.

There are four options of Power Management, three of which have fixed mode settings

Min. Saving

Minimum power management.

Doze Mode = 1 hr.

Standby Mode = 1 hr

Suspend Mode = 1 hr.

HDD Power Down = 15 min

Max Saving

Maximum power management only available for sl CPU's.

Doze Mode = 1 min

Standby Mode = 1 min.

Suspend Mode = 1 min.

HDD Power Down = 1 min.

User Defined (default)

Allows you to set each mode individually.

When not disabled, each of the ranges are from 1 min. to 1 hr. except for HDD Power Down which ranges from 1 min. to 15 min. and disable.

Video Off Method

This option determines the manner in which the monitor is goes blank.

V/H SYNC+Blank

This selection will cause the system to turn off the vertical and horizontal synchronization ports and write blanks to the video buffer.

Blank Screen

This option only writes blanks to the video buffer.

DPMS (default)

Initial display power management signaling

P4TSV BIOS Setup

Video Off In Suspend

This determines the manner in which the monitor is blanked.

The Choices: Yes (default), No.

Suspend Type

Select the Suspend Type.

The Choices: Stop Grant (default), PwrOn Suspend.

MODEM Use IRQ

This determines the IRQ, which can be applied in MODEM use.

The Choices:3 (default)/ 4 / 5 / 7 / 9 / 10 / 11 / NA.

Suspend Mode

When enabled and after the set time of system inactivity, all devices except the CPU will be shut off.

The Choices: Disabled (default), 1Min, 2Min, 4Min, 8Min, 12Min, 20Min, 30Min, 40Min, 1Hour.

HDD Power Down

When enabled and after the set time of system inactivity, the hard disk drive will be powered down while all other devices remain active.

The Choices: Disabled (default), 1Min, 2Min, 3Min, 4Min, 5Min, 6Min, 7Min, 8Min, 9Min, 10Min, 11Min, 12Min, 13Min, 14Min, 15Min.

Soft-Off by PWR-BTTN

Pressing the power button for more than 4 seconds forces the system to enter the Soft-Off state when the system has "hung."

The Choices: Delay 4 Sec, Instant-Off (default).

Intruder# Detection

This item allows you to enable or disable intruder# detection.

The Choices: Disabled (Default), Enabled.

Wake-Up by PCI card

When you select Enable, a PME signal from PCI card returns the system to Full On state.

The Choices: Enabled, Disabled (default).

Power On by Ring

An input signal on the serial Ring Indicator (RI) line (in other words, an

P4TSV BIOS Setup

incoming call on the modem) awakens the system from a soft off state.

The Choices: Enabled, **Disabled** (default).

USB KB Wake-Up From S3

This item allows you to enable or disabled USB keyboard wake up from S3.

The Choices: **Disabled** (Default), Enabled.

Resume by Alarm

This function is for setting date and time for your computer to boot up. During Disabled, you cannot use this function. During Enabled, Choose the Date and Time.

Alarm: **Date (of Month) Alarm** You can choose which month the system will boot up.

Time (hh:mm:ss) Alarm You can choose what hour, minute and second the system will boot up.

Note: If you have change the setting, you must let the system boot up until it goes to the operating system, before this function will work.

P4TSV BIOS Setup

7 PnP/PCI Configurations

This section describes configuring the PCI bus system. PCI, or Personal Computer Interconnect, is a system which allows I/O devices to operate at speeds nearing the speed of the CPU itself uses when communicating with its own special components. This section covers some very technical items and it is strongly recommended that only experienced users should make any changes to the default settings.

■ Figure 7. PnP/PCI Configurations

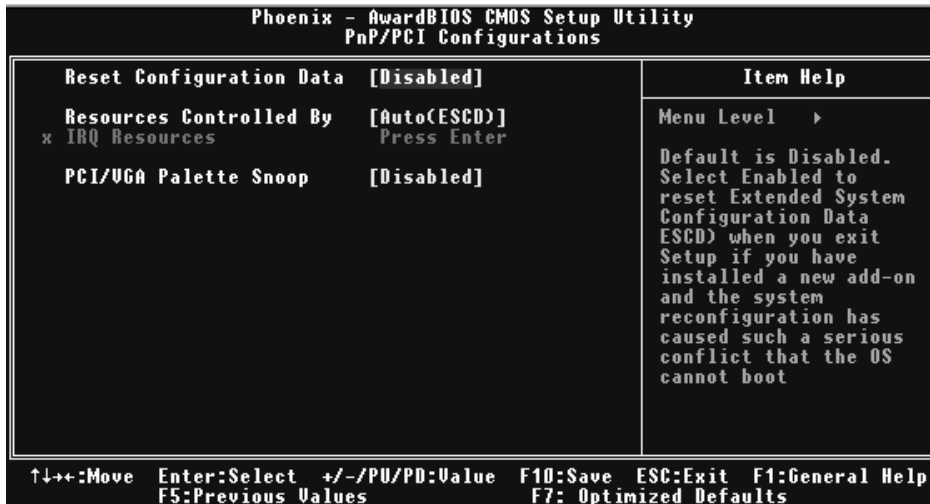

Reset Configuration Data

The system BIOS supports the PnP feature which requires the system to record which resources are assigned and protects resources from conflict. Every peripheral device has a node, which is called ESCD. This node records which resources are assigned to it. The system needs to record and update ESCD to the memory locations. These locations (4K) are reserved in the system BIOS. If the Disabled (default) option is chosen, the system's ESCD will update only when the new configuration varies from the last one. If the Enabled option is chosen, the system is forced to update ESCDs and then is automatically set to the "Disabled" mode.

The above settings will be shown on the screen only if "Manual" is chosen for the resources controlled by function.

Legacy is the term, which signifies that a resource is assigned to the ISA Bus and provides non-PnP ISA add-on cards. PCI / ISA PnP signifies that a resource is assigned to the PCI Bus or provides for ISA PnP add-on cards and peripherals.

The Choices: Disabled (default), Enabled.

P4TSV BIOS Setup

Resources Controlled By

By Choosing “**Auto(ESCD)**” (default), the system BIOS will detect the system resources and automatically assign the relative IRQ and DMA channel for each peripheral. By Choosing “**Manual**”, the user will need to assign IRQ & DMA for add-on cards. Be sure that there are no IRQ/DMA and I/O port conflicts.

I/O Resources

This submenu will allow you to assign each system interrupt a type, depending on the type of device using the interrupt. When you press the “Press Enter” tag, you will be directed to a submenu that will allow you to configure the system interrupts. This is only configurable when “Resources Controlled By” is set to “Manual”.

IRQ-3	assigned to	PCI Device
IRQ-4	assigned to	PCI Device
IRQ-5	assigned to	PCI Device
IRQ-7	assigned to	PCI Device
IRQ-9	assigned to	PCI Device
IRQ-10	assigned to	PCI Device
IRQ-11	assigned to	PCI Device
IRQ-12	assigned to	PCI Device
IRQ-14	assigned to	PCI Device
IRQ-15	assigned to	PCI Device

PCI / VGA Palette Snoop

Choose Disabled or Enabled. Some graphic controllers which are not VGA compatible take the output from a VGA controller and map it to their display as a way to provide boot information and VGA compatibility.

However, the color information coming from the VGA controller is drawn from the palette table inside the VGA controller to generate the proper colors, and the graphic controller needs to know what is in the palette of the VGA controller. To do this, the non-VGA graphic controller watch for the Write access to the VGA palette and registers the snoop data. In PCI based systems, where the VGA controller is on the PCI bus and a non-VGA graphic controller is on an ISA bus, the Write Access to the palette will not show up on the ISA bus if the PCI VGA controller responds to the Write.

In this case, the PCI VGA controller should not respond to the Write, it should only snoop the data and permit the access to be forwarded to the ISA bus. The non-VGA ISA graphic controller can then snoop the data on the ISA bus. Unless you have the above situation, you should disable this option.

Disabled (default)	Disable the function.
Enabled	Enable the function.

P4TSV BIOS Setup

8 PC Health Status

■ Figure 8. PC Health Status

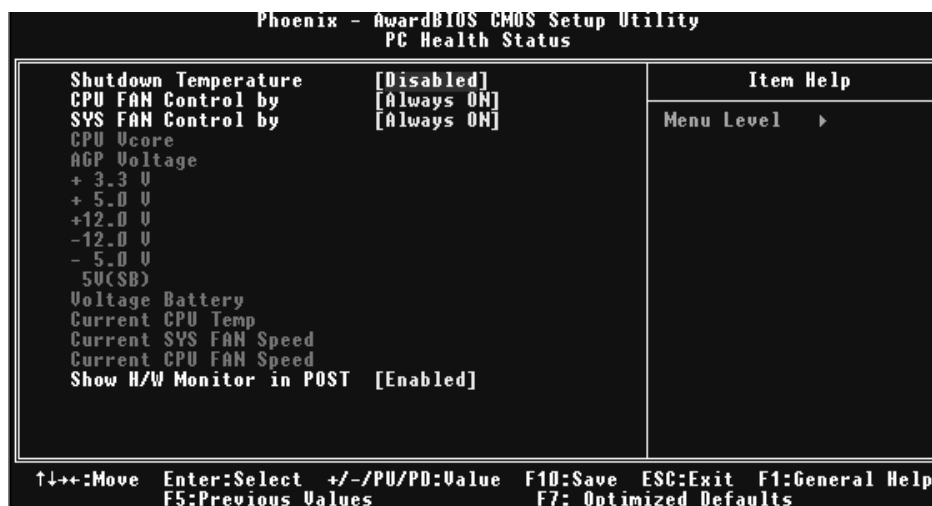

Shutdown Temperature

This item allows you to set up the CPU shutdown Temperature. This item is only effective under Windows 98 ACPI mode.

The Choices: 60°C/140°F, 65°C/149°F, **Disabled** (default).

CPU FAN Control by

The Choice "smart" can make your CPU FAN to reduce noise.

The Choices: Always On (default), smart.

SYS FAN Control by

The Choice "smart" can make your System FAN to reduce noise.

The Choices: Always On (default), smart.

CPU Vcore/ AGP Voltage/ +3.3V/ +5.0V/ +12V/ -12V/ -5V/ 5V(SB)/ Voltage Battery

Detect the system's voltage status automatically.

P4TSV BIOS Setup

Current CPU Temp

Show you the current CPU temperature.

Current CPU FAN Speed

This field displays the current CPUFAN speed.

Current SYS FAN Speed

This field displays the current speed SYSTEM fan.

Show H/W Monitor in POST

If you computer contain a monitoring system, it will show PC health status during POST stage. The item offers several delay time to select you want.

The Choices: Enabled (default), Disabled.

P4TSV BIOS Setup

9 Frequency Control

■ Figure 9. Frequency Control



CPU Clock Ratio

The Choices: 8 X(default), 9X, 10X, 11X, 12X, 13X, 14 X, 15X, 16X, 17X, 18X, 19X, 20 X, 21 X, 22 X, 23 X.

CPU Voltage

This item allows you to select CPU Voltage Regulator.

The Choices: Default (default), +8.1%, +5.5%, +2.5%.

DIMM Voltage

This item allows you to select DDR Voltage Regulator.

The Choices: 2.5V (Default), 2.6V, 2.7V, 2.8V.

Auto Detect PCI Clk

This item allows you to enable / disable auto Detect PCI Clock.

The Choices: Enabled (default), Disabled.

Spread Spectrum

This item allows you to enable / disable spectrum for all clock.

The Choices: Enabled (default), Disabled.

P4TSV BIOS Setup

CPU Clock

This item allows you to select CPU Clock, and CPU over clocking.



If unfortunately, the system's frequency that you are selected is not functioning, there are two methods of booting-up the system.

Method 1: Clear the COMS data by setting the JCOMS1 ((2-3) closed)) as "ON" status. All the CMOS data will be loaded as defaults setting.

Method 2: Press the <Insert> key and Power button simultaneously, after that keep-on pressing the <Insert> key until the power-on screen showed. This action will boot-up the system according to FSB of the processor.

※ It's strongly recommended to set CPU Vcore and clock in default setting. If the CPU Vcore and clock are not in default setting, it may cause CPU or M/B damage.