

FCC Information and Copyright

This equipment has been tested and found to comply with the limits of a Class B digital device, pursuant to Part 15 of the FCC Rules. These limits are designed to provide reasonable protection against harmful interference in a residential installation. This equipment generates, uses, and can radiate radio frequency energy and, if not installed and used in accordance with the instructions, may cause harmful interference to radio communications. There is no guarantee that interference will not occur in a particular installation.

The vendor makes no representations or warranties with respect to the contents here and specially disclaims any implied warranties of merchantability or fitness for any purpose. Further the vendor reserves the right to revise this publication and to make changes to the contents here without obligation to notify any party beforehand.

Duplication of this publication, in part or in whole, is not allowed without first obtaining the vendor's approval in writing.

The content of this user's manual is subject to be changed without notice and we will not be responsible for any mistakes found in this user's manual. All the brand and product names are trademarks of their respective companies.

Table of Contents

Chapter 1: Introduction	3
1.1 Before You Start	3
1.2 Package Checklist	3
1.3 Motherboard Features	4
1.4 Rear Panel Connectors	6
1.5 Motherboard Layout	7
Chapter 2: Hardware Installation	8
2.1 Installing Central Processing Unit (CPU)	8
2.2 FAN Headers	10
2.3 Installing System Memory	11
2.4 Connectors and Slots	13
Chapter 3: Headers & Jumpers Setup	15
3.1 How to Setup Jumpers	15
3.2 Detail Settings	15
Chapter 4: RAID Functions	23
4.1 Operation System	23
4.2 Raid Arrays	23
4.3 How RAID Works	23
Chapter 5: OverClock Quick Guide	27
5.1 T-Power Introduction	27
5.2 T-Power BIOS Feature	28
5.3 T-Power Windows Feature	36
Chapter 6: Useful Help	41
6.1 Driver Installation Note	41
6.2 Award BIOS Beep Code	42
6.3 Extra Information	42
6.4 Troubleshooting	43
Appendencies: SPEC In Other Language	44
German	44
France	46
Italian	48
Spanish	50
Portuguese	52
Polish	54
Russian	56
Arabic	58
Japanese	60

CHAPTER 1: INTRODUCTION

1.1 BEFORE YOU START

Thank you for choosing our product. Before you start installing the motherboard, please make sure you follow the instructions below:

- Prepare a dry and stable working environment with sufficient lighting.
- Always disconnect the computer from power outlet before operation.
- Before you take the motherboard out from anti-static bag, ground yourself properly by touching any safely grounded appliance, or use grounded wrist strap to remove the static charge.
- Avoid touching the components on motherboard or the rear side of the board unless necessary. Hold the board on the edge, do not try to bend or flex the board.
- Do not leave any unfastened small parts inside the case after installation. Loose parts will cause short circuits which may damage the equipment.
- Keep the computer from dangerous area, such as heat source, humid air and water.

1.2 PACKAGE CHECKLIST

- ✚ HDD Cable X 1
- ✚ Serial ATA Cable X 2
- ✚ Serial ATA Power Cable X 1
- ✚ Rear I/O Panel for ATX Case X 1
- ✚ User's Manual X 1
- ✚ Fully Setup Driver CD X 1
- ✚ FDD Cable X 1 (optional)
- ✚ USB 2.0 Cable X1 (optional)
- ✚ S/PDIF out Cable X 1 (optional)

Note: The package contents may differ by area or your motherboard version.

1.3 MOTHERBOARD FEATURES

	<i>TF7150U-M7</i>	<i>TF7100P-M7</i>
CPU	LGA 775 Intel Core2Duo / Core2Quad / Celeron 4xx / Pentium D / Pentium 4 processor Supports 45nm CPU Supports Hyper-Threading / Execute Disable Bit / Enhanced Intel SpeedStep® / Intel Architecture-64 / Extended Memory 64 Technology / Virtualization Technology	LGA 775 Intel Core2Duo / Core2Quad / Celeron 4xx / Pentium D / Pentium 4 processor Supports 45nm CPU Supports Hyper-Threading / Execute Disable Bit / Enhanced Intel SpeedStep® / Intel Architecture-64 / Extended Memory 64 Technology / Virtualization Technology
FSB	Support 1333 MHz	Support 1333 MHz
Chipset	GeForce 7150/nForce 630i	GeForce 7100/nForce 630i
Super I/O	ITE 8718F Provides the most commonly used legacy Super I/O functionality. Low Pin Count Interface Environment Control initiatives, H/W Monitor Fan Speed Controller ITE's "Smart Guardian" function	ITE 8718F Provides the most commonly used legacy Super I/O functionality. Low Pin Count Interface Environment Control initiatives, H/W Monitor Fan Speed Controller ITE's "Smart Guardian" function
Main Memory	DDR2 DIMM Slots x 2 Max Memory Capacity 4GB Each DIMM supports 512MB/1GB/2GB DDR2 Single Channel Mode DDR2 memory module Supports DDR2 533 / 667 / 800 Registered DIMM and ECC DIMM is not supported	DDR2 DIMM Slots x 2 Max Memory Capacity 4GB Each DIMM supports 512MB/1GB/2GB DDR2 Single Channel Mode DDR2 memory module Supports DDR2 533 / 667 / 800 Registered DIMM and ECC DIMM is not supported
Graphics	GeForce 7150/nForce 630i Max Shared Video Memory is 512MB (under OS)	GeForce 7100/nForce 630i Max Shared Video Memory is 512MB (under OS)
IDE	Integrated IDE Controller Ultra DMA 33 / 66 / 100 / 133 Bus Master Mode supports PIO Mode 0~4,	Integrated IDE Controller Ultra DMA 33 / 66 / 100 / 133 Bus Master Mode supports PIO Mode 0~4,
SATA II	Integrated Serial ATA Controller Data transfer rates up to 3 Gb/s. SATA Version 2.0 specification compliant.	Integrated Serial ATA Controller Data transfer rates up to 3 Gb/s. SATA Version 2.0 specification compliant.
LAN	Realtek 8111B / 8111C(optional) 10 / 100 Mb/s and 1Gb/s Auto-Negotiation Half / Full duplex capability	Realtek 8111B / 8111C(optional) 10 / 100 Mb/s and 1Gb/s Auto-Negotiation Half / Full duplex capability

TF7150U-M7/TF7100P-M7

	TF7150U-M7	TF7100P-M7
Sound	ALC888 / Integrated in GeForce 7150 nForce 630i (for HDMI Audio) 7.1 channels audio out (ALC888) 2 channels audio out (for HDMI Audio) High Definition Audio	ALC888 / Integrated in GeForce 7100 nForce 630i (for HDMI Audio) 7.1 channels audio out (ALC888) 2 channels audio out (for HDMI Audio) High Definition Audio
Slots	PCI slot x2 PCI Express x16 slot x1 PCI Express x 1 slot x1	PCI slot x2 PCI Express x16 slot x1 PCI Express x 1 slot x1
On Board Connector	Floppy connector x1 Printer Port connector x1 IDE Connector x1 SATA Connector x4 Front Panel Connector x1 Front Audio Connector x1 CD-in Connector x1 S/PDIF out connector x1 CPU Fan header x1 System Fan header x2 CMOS clear header x1 USB connector x3 Serial port Connector x1 Power Connector (24pin) x1 Power Connector (4pin) x1	Floppy connector x1 Printer Port connector x1 IDE Connector x1 SATA Connector x4 Front Panel Connector x1 Front Audio Connector x1 CD-in Connector x1 S/PDIF out connector x1 CPU Fan header x1 System Fan header x2 CMOS clear header x1 USB connector x3 Serial port Connector x1 Power Connector (24pin) x1 Power Connector (4pin) x1
Back Panel I/O	PS/2 Keyboard x1 HDMI port x1 VGA port x1 DVI-D port x1 LAN port x1 USB Port x4 Audio Jack x6	PS/2 Keyboard x1 HDMI port x1 VGA port x1 DVI-D port x1 LAN port x1 USB Port x4 Audio Jack x6
Board Size	244 mm(W) x 244 mm(L)	244 mm(W) x 244 mm(L)
Special Features	RAID 0 / 1 / 5 / 0+1 support	RAID 0 / 1 / 5 / 0+1 support
OS Support	Windows XP / VISTA Biostar Reserves the right to add or remove support for any OS With or without notice.	Windows XP / VISTA Biostar Reserves the right to add or remove support for any OS With or without notice.

1.4 REAR PANEL CONNECTORS

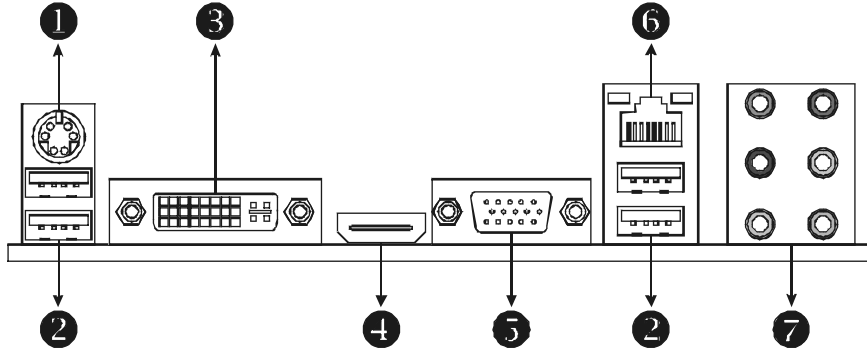

1 PS/2 Keyboard Port

2 USB 2.0 Port x 2

3 DVI-D VGA Port

The Digital Visual Interface (DVI) is a video interface transmitting digital video signals to digital display devices such as flat panel LCDs or digital projectors. The DVI-D connector allows digital signals transmission only.

4 HDMI Port

The High-Definition Multimedia Interface (HDMI) is an all-digital audio/video interface capable of transmitting uncompressed streams to an AV receiver or any compatible digital audio and/or video monitor, such as a digital television.

5 D-Sub VGA Port

Transmit analog video signals to computer monitor or any other display panels equipped with D-Sub VGA input.

6 10/100/1000 Mbps LAN Port

7 Audio Jack x 6

Port	2-Channel	4-Channel	6-Channel/8-Channel
Blue	Line-In	Line-In	Line-In
Green	Line-Out	Front Speaker Out	Front Speaker Out
Pink	Mic In	Mic In	Mic In
Orange			Center/Subwoofer
Black	Rear Speaker Out	Rear Speaker Out	Rear Speaker Out
Grey			Side Speaker Out

NOTE: The HDMI and DVI-D ports both can provide digital video signals out-put function, but these two interfaces cannot work at the same time. The chipset uses the same channel to control HDMI and DVI-D, so these ports cannot transmit video signal to different display panels simultaneously.

1.5 MOTHERBOARD LAYOUT

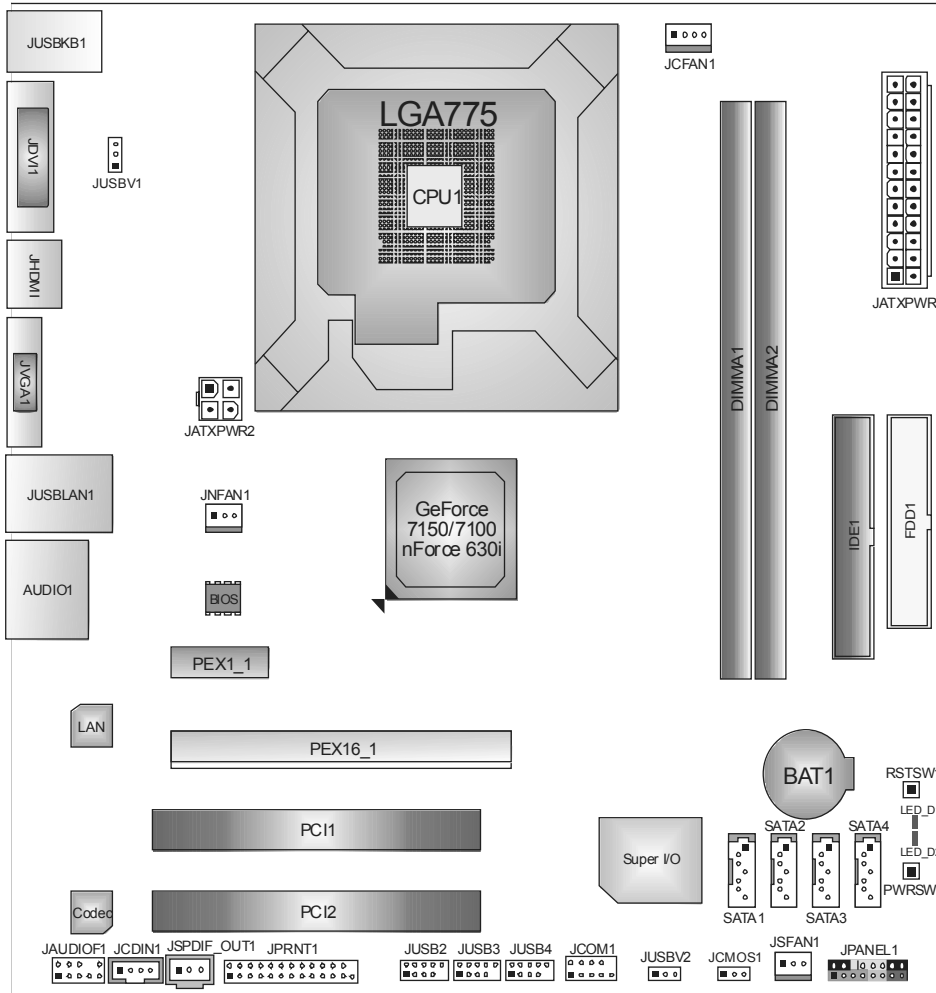

Note: ■ represents the 1st pin.

CHAPTER 2: HARDWARE INSTALLATION

2.1 INSTALLING CENTRAL PROCESSING UNIT (CPU)

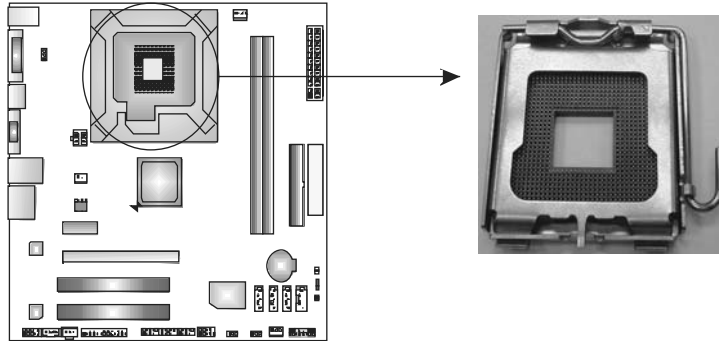

Special Notice:

Remove Pin Cap before installation, and make good preservation for future use. When the CPU is removed, cover the Pin Cap on the empty socket to ensure pin legs won't be damaged.

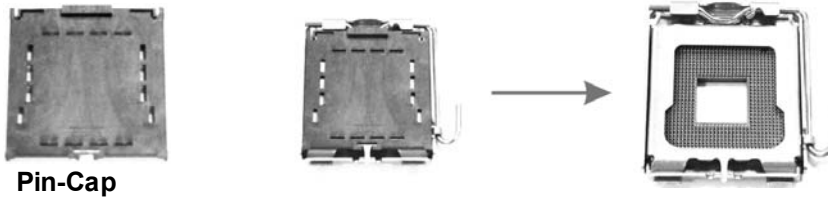

Step 1: Pull the socket locking lever out from the socket and then raise the lever up to a 90-degree angle.

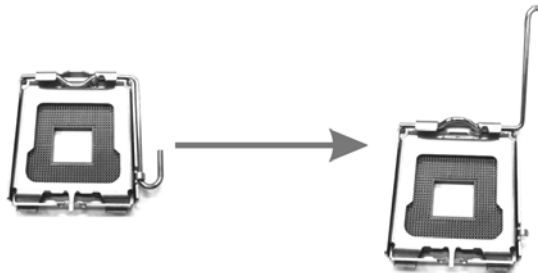

TF7150U-M7/TF7100P-M7

Step 2: Look for the triangular cut edge on socket, and the golden dot on CPU should point forwards this triangular cut edge. The CPU will fit only in the correct orientation.

Step 2-1:

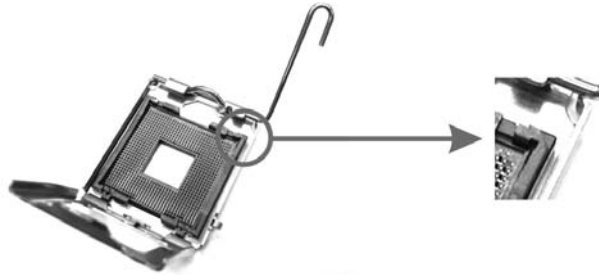

Step 2-2:

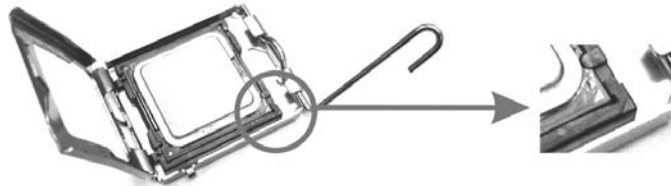

Step 3: Hold the CPU down firmly, and then lower the lever to locked position to complete the installation.



Step 4: Put the CPU Fan and heatsink assembly on the CPU and buckle it on the retention frame. Connect the CPU FAN power cable into the JCFAN1. This completes the installation.

2.2 FAN HEADERS

These fan headers support cooling-fans built in the computer. The fan cable and connector may be different according to the fan manufacturer. Connect the fan cable to the connector while matching the black wire to pin#1.

JCFAN1: CPU Fan Header

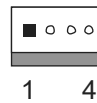
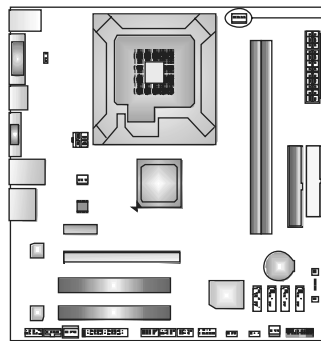

Pin	Assignment
1	Ground
2	+12V
3	FAN RPM rate sense
4	Smart Fan Control (By Fan)

JNFAN1: North Bridge Fan Header

JSFAN1: System Fan Header

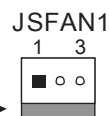
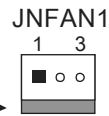
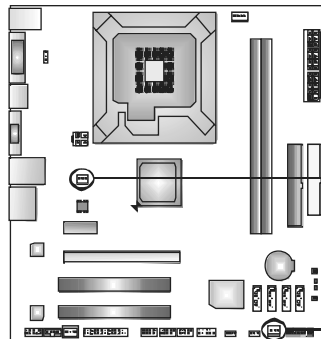

Pin	Assignment
1	Ground
2	+12V
3	FAN RPM rate sense

Note:

The JCFAN1 supports 4-pin head connector. The JSFAN1 and JNFAN1 support 3-pin head connectors. When connecting with wires onto connectors, please note that the red wire is the positive and should be connected to pin#2, and the black wire is Ground and should be connected to GND.

2.3 INSTALLING SYSTEM MEMORY

A. Memory Modules

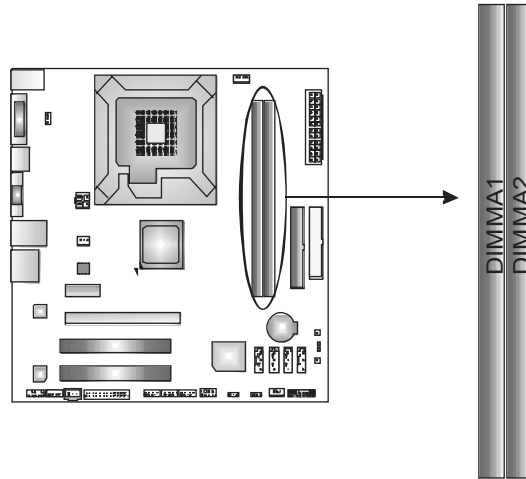

1. Unlock a DIMM slot by pressing the retaining clips outward. Align a DIMM on the slot such that the notch on the DIMM matches the break on the Slot.

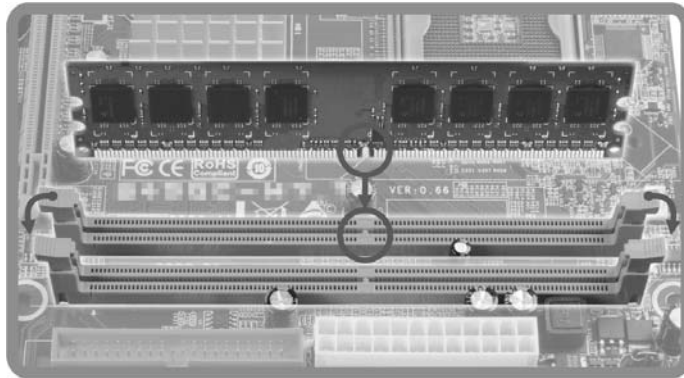

2. Insert the DIMM vertically and firmly into the slot until the retaining chip snap back in place and the DIMM is properly seated.

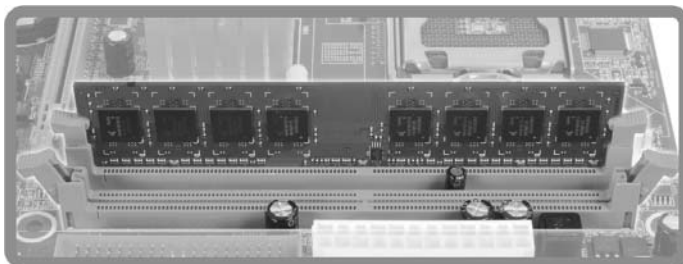

B. Memory Capacity

DIMM Socket Location	DDR2 Module	Total Memory Size
DIMMA1	512MB/1024MB/2048MB	Max is 4GB.
DIMMA2	512MB/1024MB/2048MB	

2.4 CONNECTORS AND SLOTS

FDD1: Floppy Disk Connector

The motherboard provides a standard floppy disk connector that supports 360K, 720K, 1.2M, 1.44M and 2.88M floppy disk types. This connector supports the provided floppy drive ribbon cable.

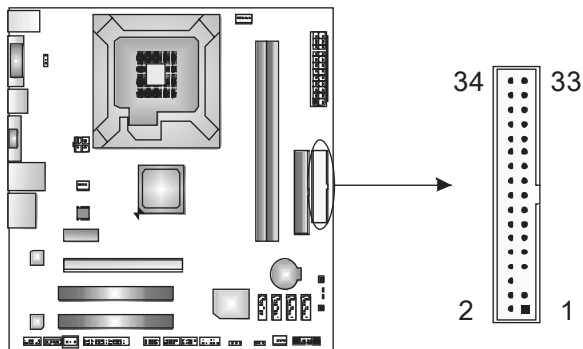

IDE1: Hard Disk Connector

The motherboard has a 32-bit Enhanced PCI IDE Controller that provides PIO Mode 0~4, Bus Master, and Ultra DMA 33/66/100/133 functionality.

The IDE connector can connect a master and a slave drive, so you can connect up to two IDE devices.

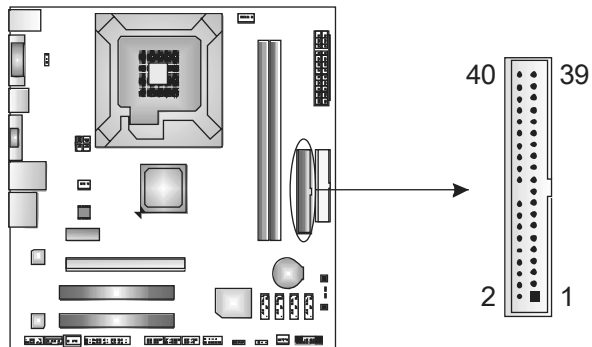

PEX16_1: PCI-Express x16 Slot

- PCI-Express 1.0a compliant.
- Maximum theoretical realized bandwidth of 4GB/s simultaneously per direction, for an aggregate of 8GB/s totally.

PEX1_1: PCI-Express x1 Slot

- PCI-Express 1.0a compliant.
- Data transfer bandwidth up to 250MB/s per direction; 500MB/s in total.
- PCI-Express supports a raw bit-rate of 2.5GB/s on the data pins.
- 2X bandwidth over the traditional PCI architecture.

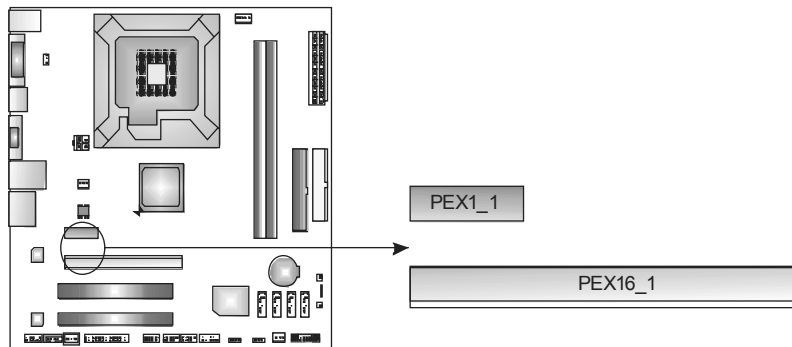

PCI1~PCI2: Peripheral Component Interconnect Slots

This motherboard is equipped with 2 standard PCI slots. PCI stands for Peripheral Component Interconnect, and it is a bus standard for expansion cards. This PCI slot is designated as 32 bits.

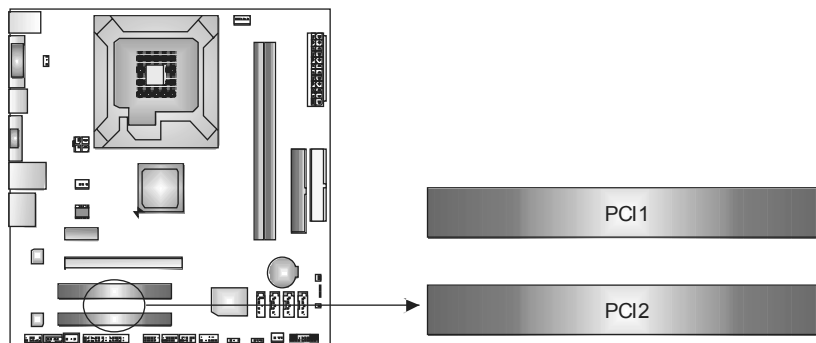

CHAPTER 3: HEADERS & JUMPERS SETUP

3.1 HOW TO SETUP JUMPERS

The illustration shows how to set up jumpers. When the jumper cap is placed on pins, the jumper is “close”, if not, that means the jumper is “open”.

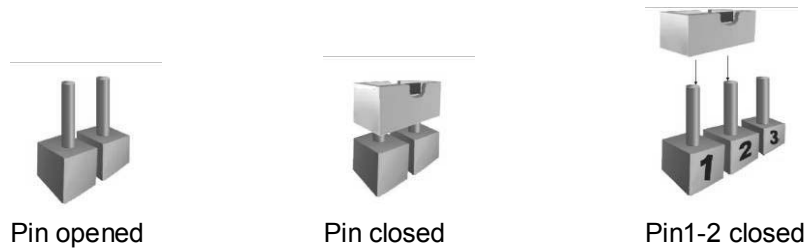

3.2 DETAIL SETTINGS

JANEL1: Front Panel Header

This 16-pin connector includes Power-on, Reset, HDD LED, Power LED, and speaker connection. It allows user to connect the PC case’s front panel switch functions.

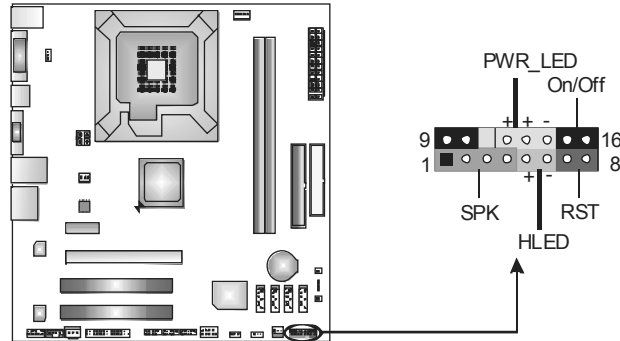

Pin	Assignment	Function	Pin	Assignment	Function
1	+5V	Speaker Connector	9	N/A	N/A
2	N/A		10	N/A	
3	N/A		11	N/A	
4	Speaker	Hard drive LED	12	Power LED (+)	Power LED
5	HDD LED (+)		13	Power LED (+)	
6	HDD LED (-)	Reset button	14	Power LED (-)	Power-on button
7	Ground		15	Power button	
8	Reset control		16	Ground	

JATXPWR1: ATX Power Source Connector

This connector allows user to connect 24-pin power connector on the ATX power supply.

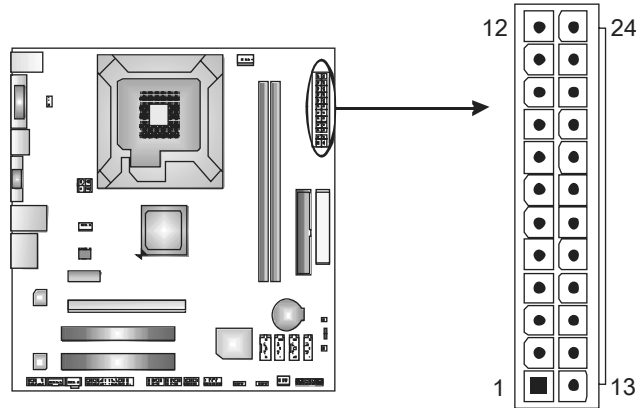

Pin	Assignment	Pin	Assignment
13	+3.3V	1	+3.3V
14	-12V	2	+3.3V
15	Ground	3	Ground
16	PS_ON	4	+5V
17	Ground	5	Ground
18	Ground	6	+5V
19	Ground	7	Ground
20	NC	8	PW_OK
21	+5V	9	Standby Voltage+5V
22	+5V	10	+12V
23	+5V	11	+12V
24	Ground	12	+3.3V

JATXPWR2: ATX Power Source Connector

By connecting this connector, it will provide +12V to CPU power circuit.

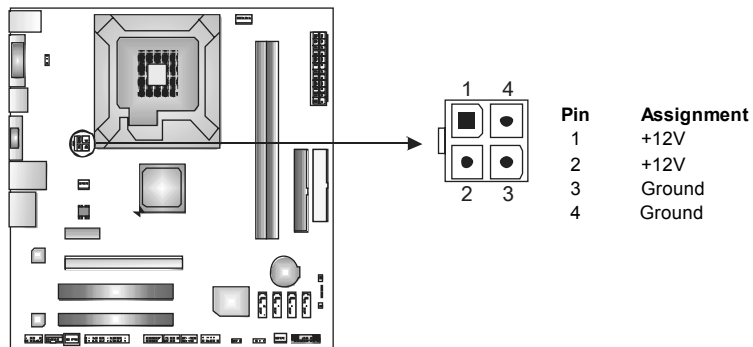

JUSB2/JUSB3/JUSB4: Headers for USB 2.0 Ports at Front Panel

This header allows user to connect additional USB cable on the PC front panel, and also can be connected with internal USB devices, like USB card reader.

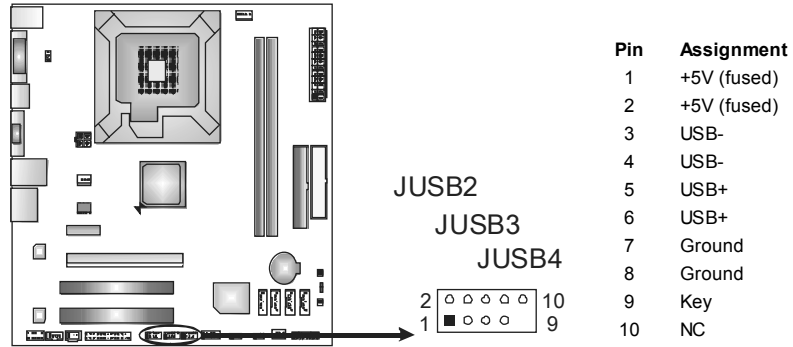

JAUDIOF1: Front Panel Audio Header

This header allows user to connect the front audio output cable with the PC front panel. It will disable the output on back panel audio connectors.

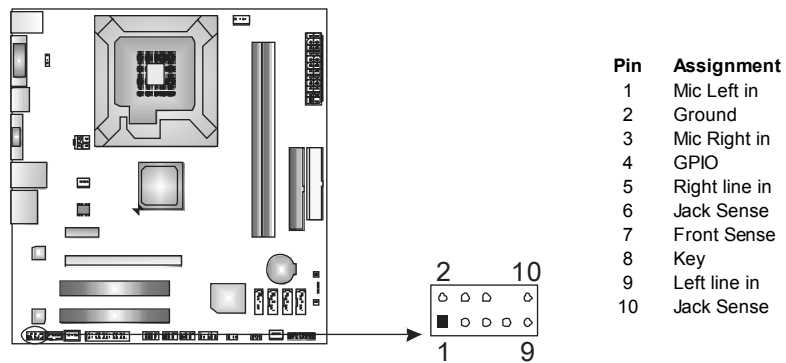

JCDIN1: CD-ROM Audio-in Connector

This connector allows user to connect the audio source from the variety devices, like CD-ROM, DVD-ROM, PCI sound card, PCI TV turner card etc..

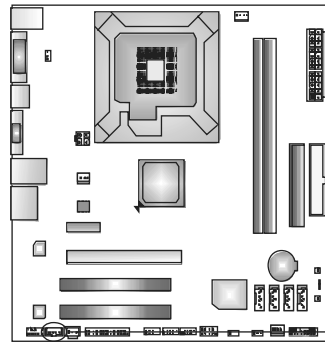

Pin	Assignment
1	Left Channel Input
2	Ground
3	Ground
4	Right Channel Input

JCMOS1: Clear CMOS Header

By placing the jumper on pin2-3, it allows user to restore the BIOS safe setting and the CMOS data, please carefully follow the procedures to avoid damaging the motherboard.

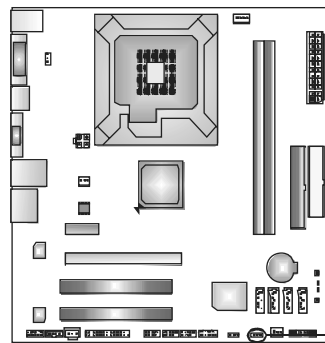

Pin 1-2 Close:
Normal Operation
(default).



Pin 2-3 Close:
Clear CMOS data.

※ Clear CMOS Procedures:

1. Remove AC power line.
2. Set the jumper to "Pin 2-3 close".
3. Wait for five seconds.
4. Set the jumper to "Pin 1-2 close".
5. Power on the AC.
6. Reset your desired password or clear the CMOS data.

SATA1~SATA4: Serial ATA Connectors

The motherboard has a PCI to SATA Controller with 4 channels SATA interface.

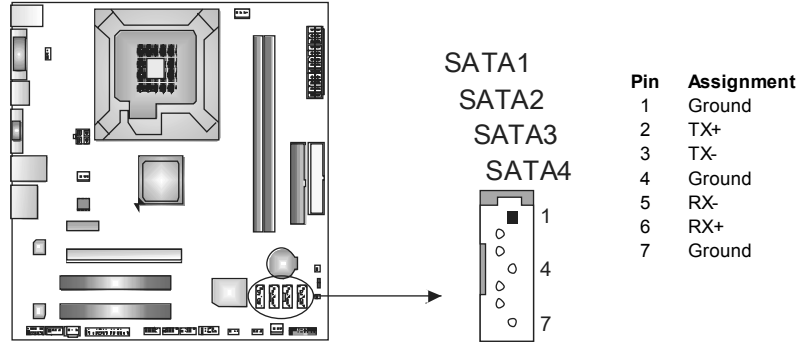

JPRNT1: Printer Port Connector

This header allows you to connector printer on the PC.

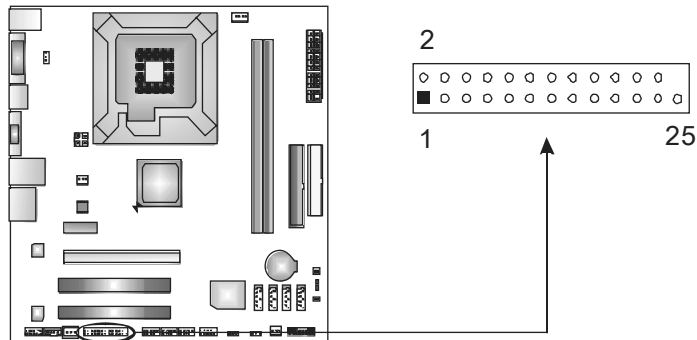

Pin	Assignment	Pin	Assignment
1	-Strobe	14	Ground
2	-ALF	15	Data 6
3	Data 0	16	Ground
4	-Error	17	Data 7
5	Data 1	18	Ground
6	-Init	19	-ACK
7	Data 2	20	Ground
8	-Sctin	21	Busy
9	Data 3	22	Ground
10	Ground	23	PE
11	Data 4	24	Ground
12	Ground	25	SCLT
13	Data 5	26	Key

JSPDIF_OUT1: Digital Audio-out Connector

This connector allows user to connect the PCI bracket SPDIF output header.

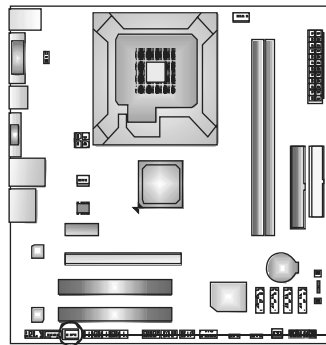

Pin	Assignment
1	+5V
2	SPDIF_OUT
3	Ground

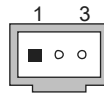

JCOM1: Serial port Connector

The motherboard has a Serial Port Connector for connecting RS-232 Port.

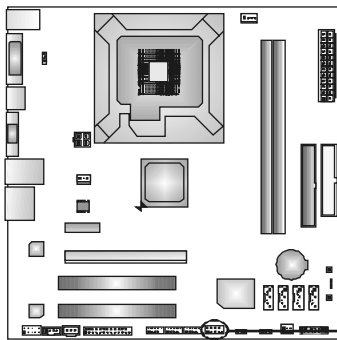

Pin	Assignment
1	Carrier detect
2	Received data
3	Transmitted data
4	Data terminal ready
5	Signal ground
6	Data set ready
7	Request to send
8	Clear to send
9	Ring indicator
10	Key

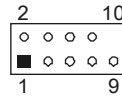

On-Board Buttons

There are 2 on-board buttons.

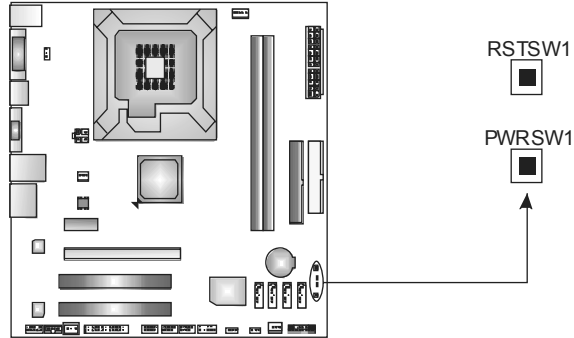

PWRSW1:

This is an on-board Power Switch button.

RSTSW1:

This is an on-board Reset button.

On-Board LED Indicators

There are 2 LED indicators on the motherboard to show system status.

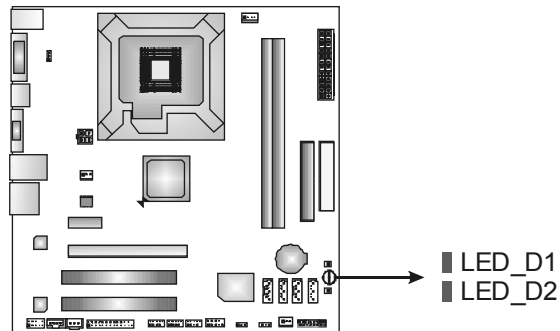

LED_D1 and LED_D2:

These 2 LED indicate system power on diagnostics.

Please refer to the table below for different messages:

LED_D2	LED_D1	Message
OFF	OFF	Abnormal: CPU / Chipset error.
OFF	ON	Memory Error
ON	OFF	VGA Error
ON	ON	Normal

JUSBV1/JUSBV2: Power Source Headers for USB Ports

Pin 1-2 Close:

JUSBV1: +5V for USB ports at JUSBKB1/JUSBLAN1.

JUSBV2: +5V for USB ports at JUSB2/JUSB3/JUSB4.

Pin 2-3 Close:

JUSBV1: USB ports at JUSBKB1/JUSBLAN1 are powered by +5V standby voltage.

JUSBV2: USB ports at JUSB2/JUSB3/JUSB4 are powered by +5V standby voltage.

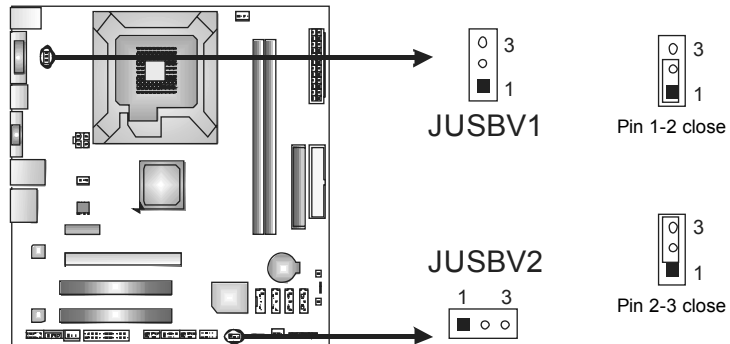

CHAPTER 4: RAID FUNCTIONS

4.1 OPERATION SYSTEM

- Supports Windows XP Home/Professional Edition, and Windows Vista.

4.2 RAID ARRAYS

RAID supports the following types of RAID arrays:

RAID 0: RAID 0 defines a disk striping scheme that improves disk read and write times for many applications.

RAID 1: RAID 1 defines techniques for mirroring data.

RAID 0+1: RAID 0+1 combines the techniques used in RAID 0 and RAID 1.

RAID 5: RAID 5 provides fault tolerance and better utilization of disk capacity.

4.3 How RAID WORKS

RAID 0:

The controller “stripes” data across multiple drives in a RAID 0 array system. It breaks up a large file into smaller blocks and performs disk reads and writes across multiple drives in parallel. The size of each block is determined by the stripe size parameter, which you set during the creation of the RAID set based on the system environment. This technique reduces overall disk access time and offers high bandwidth.

Features and Benefits

- **Drives:** Minimum 1, and maximum is up to 6 or 8. Depending on the platform.
- **Uses:** Intended for non-critical data requiring high data throughput, or any environment that does not require fault tolerance.
- **Benefits:** provides increased data throughput, especially for large files. No capacity loss penalty for parity.
- **Drawbacks:** Does not deliver any fault tolerance. If any drive in the array fails, all data is lost.
- **Fault Tolerance:** No.

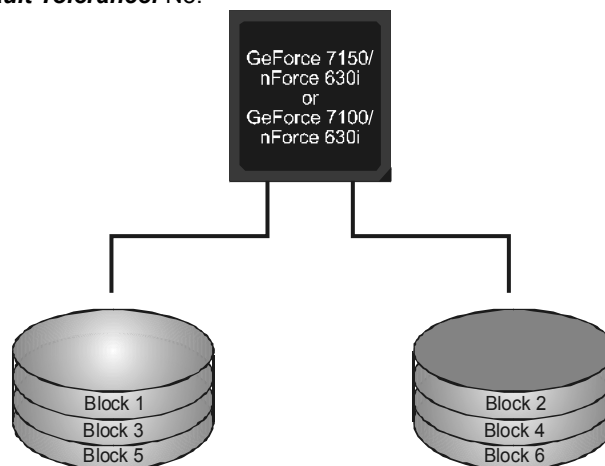

RAID 1:

Every read and write is actually carried out in parallel across 2 disk drives in a RAID 1 array system. The mirrored (backup) copy of the data can reside on the same disk or on a second redundant drive in the array. RAID 1 provides a hot-standby copy of data if the active volume or drive is corrupted or becomes unavailable because of a hardware failure. RAID techniques can be applied for high-availability solutions, or as a form of automatic backup that eliminates tedious manual backups to more expensive and less reliable media.

Features and Benefits

- **Drives:** Minimum 2, and maximum is 2.
- **Uses:** RAID 1 is ideal for small databases or any other application that requires fault tolerance and minimal capacity.
- **Benefits:** Provides 100% data redundancy. Should one drive fail, the controller switches to the other drive.
- **Drawbacks:** Requires 2 drives for the storage space of one drive. Performance is impaired during drive rebuilds.
- **Fault Tolerance:** Yes.

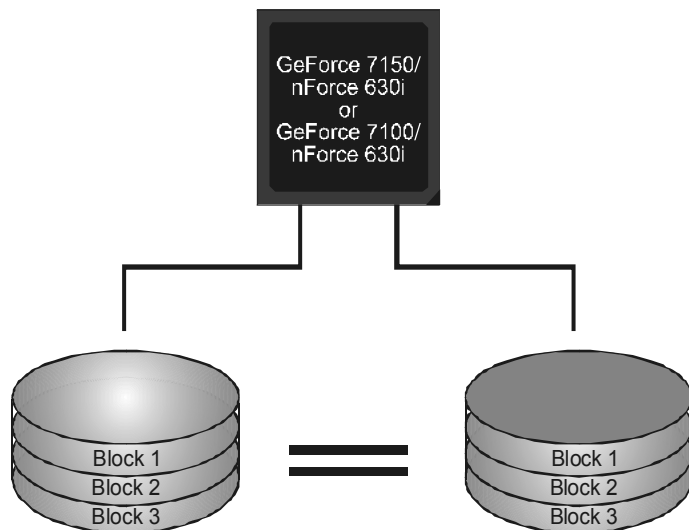

RAID 0+1:

RAID 0 drives can be mirrored using RAID 1 techniques. Resulting in a RAID 0+1 solution for improved performance plus resiliency.

Features and Benefits

- **Drives:** Minimum 4, and maximum is 6 or 8, depending on the platform.
- **Benefits:** Optimizes for both fault tolerance and performance, allowing for automatic redundancy. May be simultaneously used with other RAID levels in an array, and allows for spare disks.
- **Drawbacks:** Requires twice the available disk space for data redundancy, the same as RAID level 1.
- **Fault Tolerance:** Yes.

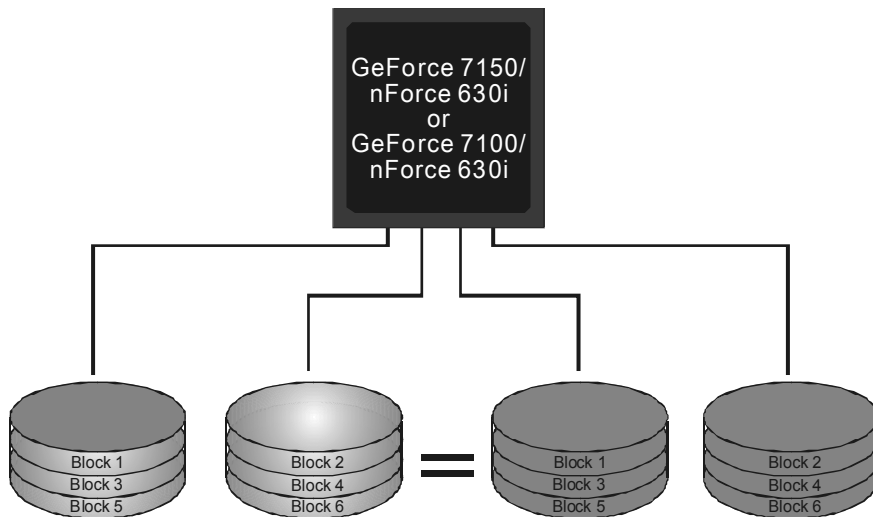

RAID 5:

RAID 5 stripes both data and parity information across three or more drives. It writes data and parity blocks across all the drives in the array. Fault tolerance is maintained by ensuring that the parity information for any given block of data is placed on a different drive from those used to store the data itself.

Features and Benefits

- **Drives:** Minimum 3.
- **Uses:** RAID 5 is recommended for transaction processing and general purpose service.
- **Benefits:** An ideal combination of good performance, good fault tolerance, and high capacity and storage efficiency.
- **Drawbacks:** Individual block data transfer rate same as a single disk. Write performance can be CPU intensive.
- **Fault Tolerance:** Yes.



※ For more detailed setup information, please refer to the Driver CD, or go to http://www.nvidia.com/object/IO_28159.html to download the NVIDIA RAID User's Guide.

CHAPTER 5: OVERCLOCK QUICK GUIDE

5.1 T-POWER INTRODUCTION

Biostar T-Power is a whole new utility that is designed for overclock users. Based on many precise tests, *Biostar Engineering Team* (BET) has developed this ultimate overclock engine to raise system performance. No matter whether under BIOS or Windows interface, *T-Power* is able to present the best system state according to users' overclock setting.

T-Power BIOS Features:

- Overclocking Navigator Engine (O.N.E.)
- CMOS Reloading Program (C.R.P.)
- Memory Integration Test (M.I.T., under Overclock Navigator Engine)
- Integrated Flash Program (I.F.P.)
- Self Recovery System (S.R.S)
- Smart Fan Function (under PC Health Status)

T-Power Windows Feature:

- Hardware Monitor
- Overclock Engine
- System Information

!! WARNING !!

For better system performance, the BIOS firmware is being continuously updated. The BIOS information described below in this manual is for your reference only and the actual BIOS information and settings on board may be different from this manual. For further information of setting up the BIOS, please refer to the BIOS Manual in the Setup CD.

5.2 T-POWER BIOS FEATURE

A. Overclocking Navigator Engine (O.N.E.):

ONE provides two powerful overclocking engines: MOS and AOS for both Elite and Casual overclockers.

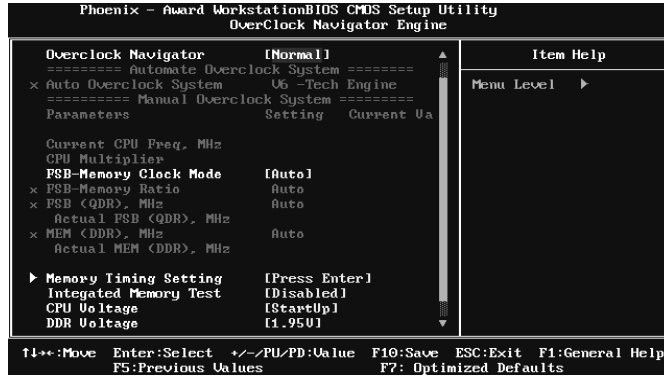

Manual Overclock System (M.O.S.)

MOS is designed for experienced overclock users.

It allows users to customize personal overclock settings.

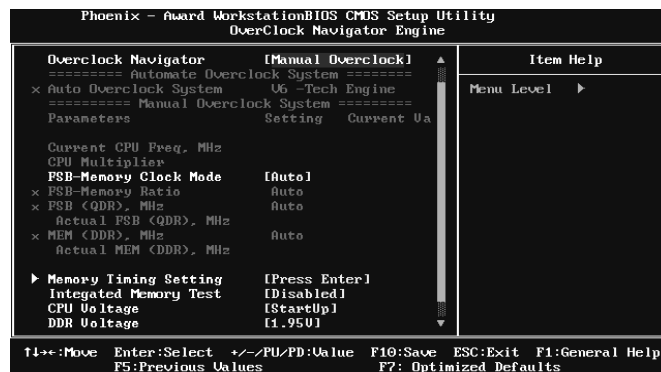
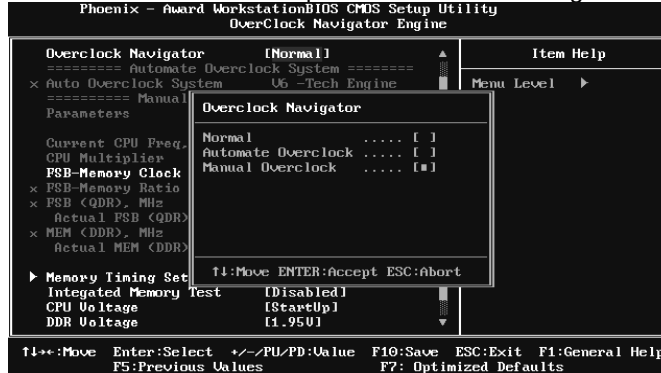

FSB-Memory Clock Mode

This item allows you to choose the memory clock mode.

FSB-Memory Ratio

This item allows you to choose the memory ratio.

FSB (QDR), MHz

This item allows you to set the FSB frequency.

MEM (DDR), MHz

This item allows you to set the memory frequency.

Memory Timing Setting

Enter this item for more advanced memory timing settings.

CPU Voltage

This function will increase CPU stability when overclocking. However, the CPU temperature will increase when CPU voltage is increased.

DDR Voltage:

This function will increase memory stability when overclocking.

NB Voltage:

This function will increase Northbridge chipset stability when overclocking.

VTT Voltage:

This function will increase memory stability when overclocking.

Automatic Overclock System (A.O.S.)

For beginners in overclock field, BET had developed an easy, fast, and powerful feature to increase the system performance, named A.O.S. Based on many tests and experiments, A.O.S. provides 3 ideal overclock configurations that are able to raise the system performance in a single step.

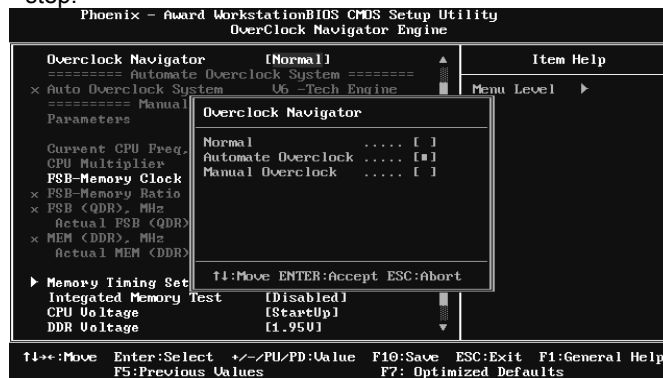

V6 Tech Engine:

This setting will raise about 10%~15% of whole system performance.

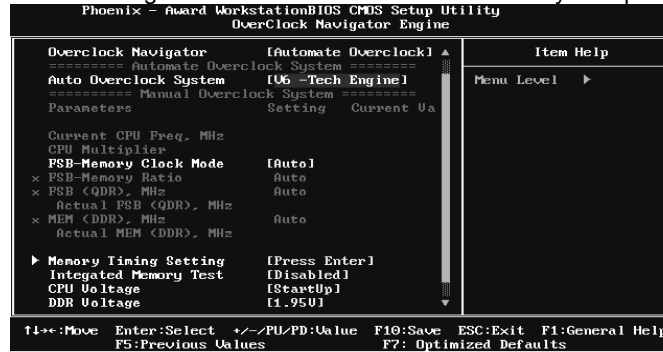

V8 Tech Engine:

This setting will raise about 15%~25% of whole system performance.

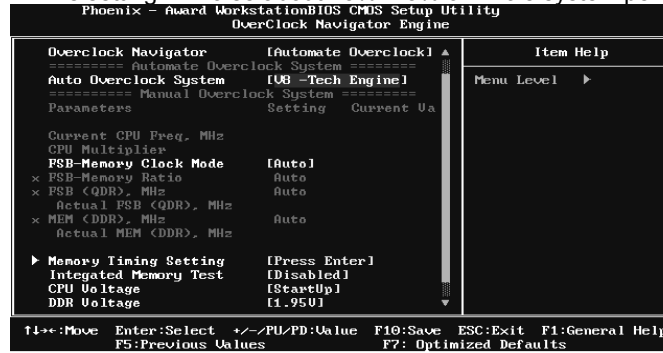

V12 Tech Engine:

This setting will raise about 25%~30% of whole system performance.

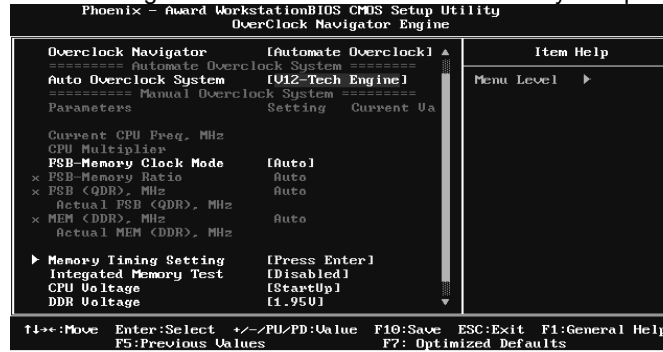

Notices:
 Not all types of AMD CPU perform above overclock setting ideally; the difference will be based on the selected CPU model.

B. CMOS Reloading Program (C.R.P.):

It allows users to save different CMOS settings into BIOS-ROM. Users are able to reload any saved CMOS setting for customizing system configurations. Moreover, users are able to save an ideal overclock setting during overclock operation. There are 50 sets of record addresses in total, and users are able to name the CMOS data according to personal preference.

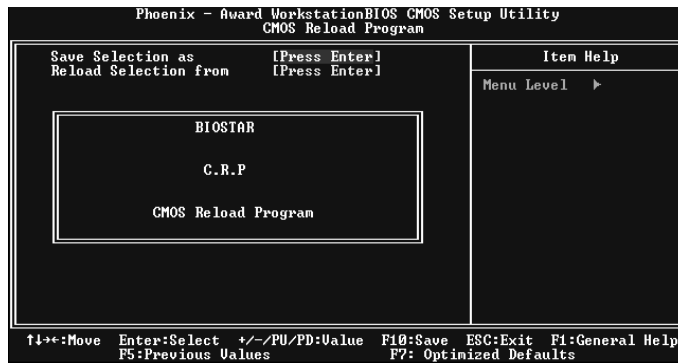

C. Memory Integration Test (M.I.T.):

This function is under “Overclocking Navigator Engine” item.

MIT allows users to test memory compatibilities, and no extra devices or software are needed.

Step 1:

The default setting under this item is “Disabled”; the condition parameter should be changed to “Enable” to proceed this test.

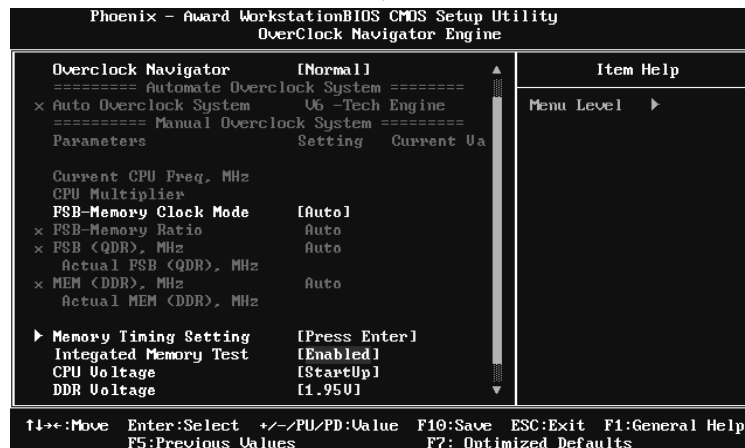
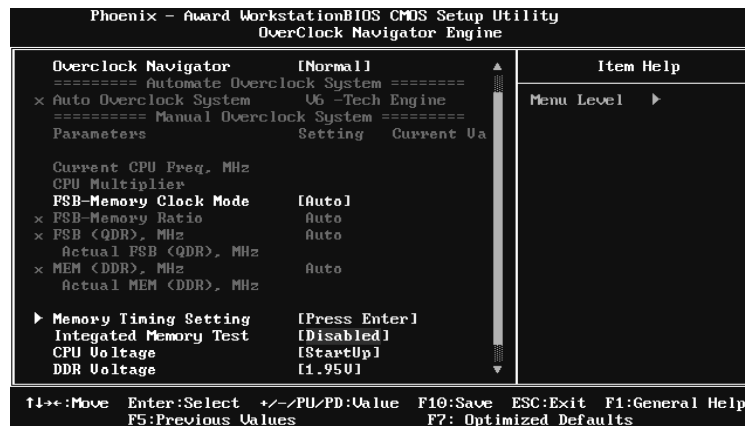

Step 2:

Save and Exit from CMOS setup and reboot the system to activate this test.

Run this test for 5 minutes (minimum) to ensure the memory stability.

Step 3:

When the process is done, change the setting back from “Enable” to “Disable” to complete the test.

D. Self Recovery System (S.R.S.):

This function can't be seen under T-Power BIOS setup; and is always on whenever the system starts up.

However, it can prevent system hang-up due to inappropriate overclock actions.

When the system hangs up, S.R.S. will automatically log in the default BIOS setting, and all overclock settings will be re-configured.

E. Integrated Flash Program (I.F.P.):

IFP is a safe and quick way to upgrade BIOS.

Step 1:

Go to Biostar website (<http://www.biostar.com.tw>) to download the latest BIOS file. Then, save the file into a floppy disk.

Step 2:

Insert the floppy disk and reboot the system to get into CMOS screen.

Step 3:

Select the item "Integrated Flash Program" to get the following frame and choose the BIOS file downloaded in step 1.

**Step 4:**

Press "Enter" key to start BIOS file loading, and BIOS updating will process automatically.

Step 5:

When the BIOS update is completed, press YES to the message "Flash done, Reset system", and the system will reboot automatically to finish the process.

Advise:

You can update the system BIOS by simply pressing "Enter" key for three times.

F. Smart Fan Function:

Smart Fan Function is under “Smart Fan Option” in “PC Health Status”.

This is a brilliant feature to control CPU/System Temperature vs. Fan speed.

When enabling Smart Fan function, Fan speed is controlled automatically by CPU/System temperature.

This function will protect CPU/System from overheat problem and maintain the system temperature at a safe level.

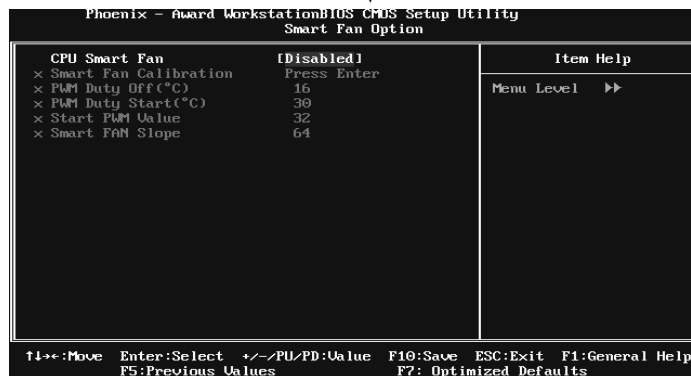
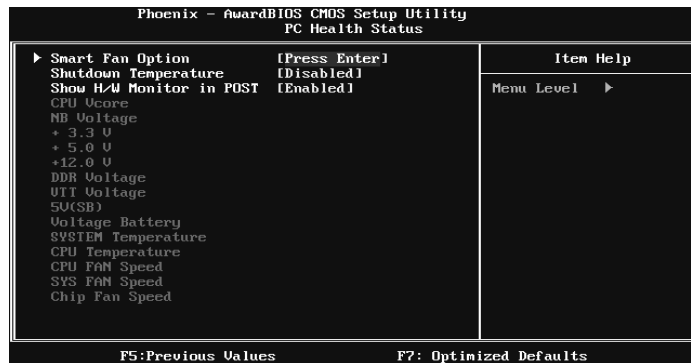

Smart Fan Calibration

Choose this item and then the BIOS will automatically test and detect the CPU/System fan functions and show CPU/System fan speed.

PWM Duty Off <°C>:

If the CPU/System temperature is lower than the set value, the CPU/System fan will turn off. The range is from 0°C~127°C, with an interval of 1°C.

PWM Duty Start <°C>

The CPU/System fan starts to work when CPU/System temperature arrives to this set value. The range is from 0°C~127°C, with an interval of 1°C.

Start PWM Value

When CPU/System temperature arrives to the set value, the CPU/System fan will work under Smart Fan Function mode. The range is from 0~127, with an interval of 1.

Smart Fan Slope

Increasing the value of slope PWM will raise the speed of CPU/System fan. The range is from 1~127, with an interval of 1.

5.3 T-POWER WINDOWS FEATURE

1. Desktop Icon

After the T-Utility has been installed, a T-Utility icon will appear on the desktop, just like the icon shown below.



Now you can launch the T-Utility simply by double-clicking the desktop icon.

2. Main Panel

If you double-click the desktop icon, T-Utility will be launched. Please refer to the following figure; the utility's first window you will see is Main Panel.

Main Panel contains features as follows:

- a. Display the CPU Speed, CPU external clock, Memory clock, VGA clock, and PCI clock information.
- b. Contains About, Overclock/Overtoltage, and Hardware Monitor Buttons for invoking respective panels. The On/Off button is for closing the program.

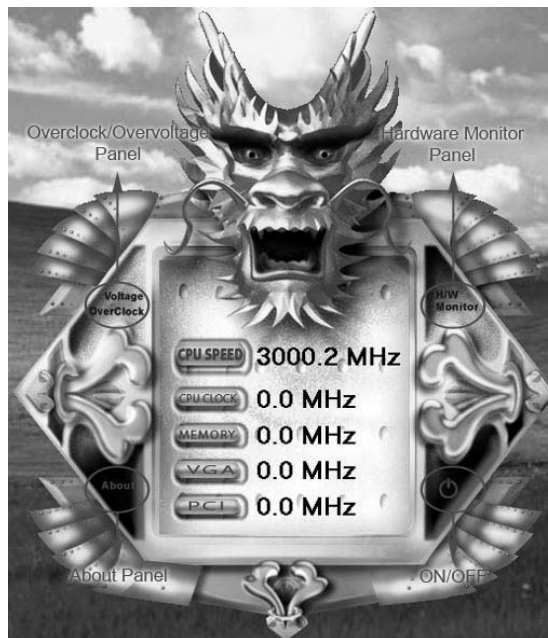

3. Overclock/Overvoltage Panel

Click the Overclock/Overvoltage button in the Main Panel, the button will be highlighted and the Overclock/Overvoltage Panel will show up as the following figure. As you can see, the Overclock Panel is on the upper side, and the Overvoltage Panel is on the lower side.

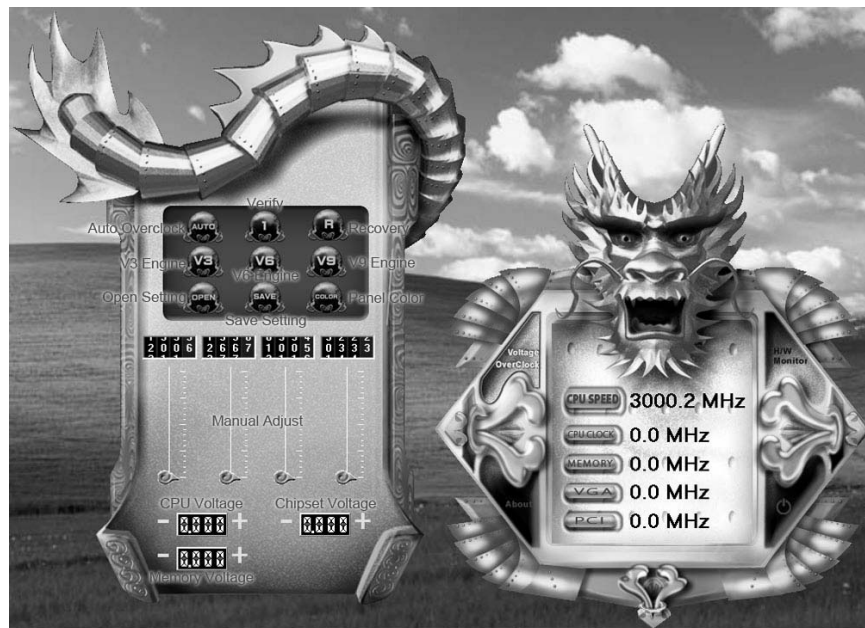

Overclock Panel contains these features:

- a. "Auto-Overclock":
User can click this button and T-Utility will set the best and stable performance and frequency automatically. A warning dialog as below will show up to notify you that the system may become unstable, click on "OK" to continue.

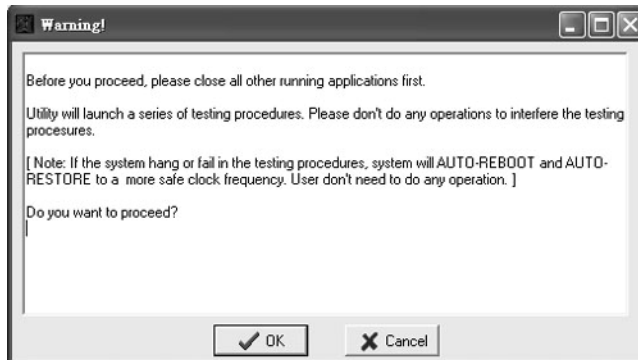

Then T-Utility will execute a series of testing until system fail. Then system will do fail-safe reboot by using Watchdog function. After reboot, launch the T-Utility again and the utility will load the previously verified best and stable frequency.

- b. "Verify":
If you use the "Manual Adjust" bar to adjust the CPU frequency, then you can click this button and T-Utility will proceed a testing for current frequency. If the testing is ok, then the current frequency will be saved into system registry. If the testing fails, system will do a fail-safe rebooting. After reboot, the T-Utility will restore to the hardware default setting.

Warning:

Manually overclock is potentially dangerous, especially when the overclocking percentage is over 110 %. We strongly recommend you verify every speed you overclock by click the Verify button. Or, you can just click Auto overclock button and let T-Utility automatically gets the best result for you.

- c. "V3 Engine"/"V6 Engine"/"V9 Engine":
Provide user the ability to do real-time overclock adjustment.
- d. "Recovery":
Click this button and the T-Utility will restore all values to the hardware default setting.

- e. "Save / Open Setting":
Click Save button to save current setting to a file, and click Open button to load a previously saved setting.
- f. "Panel Color":
Click this button to change the color of the panel.

Overvoltage Panel contains these features:

- a. "CPU Voltage":
This function allows user to adjust CPU voltage. Click on "+" to increase or "-" to decrease the CPU voltage.
- b. "Memory Voltage":
This function allows user to adjust Memory voltage. Click on "+" to increase or "-" to decrease the Memory voltage.
- c. "Chipset Voltage":
This function allows user to adjust Chipset voltage. Click on "+" to increase or "-" to decrease the Chipset voltage.

4. Hardware Monitor Panel

Click the Hardware Monitor button in Main Panel, the button will be highlighted and the Hardware Monitor panel will show up as the following figure.

In this panel, you can get the real-time status information of your system. The information will be refreshed every 1 second.

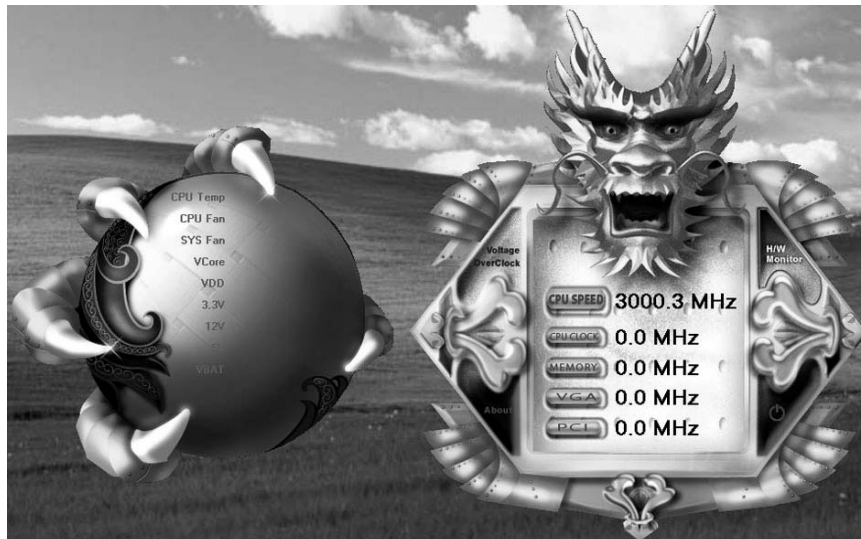

5. About Panel

Click the “about” button in Main Panel, the button will be highlighted and the About Panel will show up as the following figure.

In this panel, you can get model name and detail information in hints of all the chipset that are related to overclocking. You can also get the the version number of T-Utility.



Note:

Because the overclock, overvoltage, and hardware monitor features are controlled by several separate chipset, T-Utility divides these features to separate panels. If one chipset is not on board, the correlative button in Main panel will be disabled, but it will not interfere with other panels' functions. This property can make T-Utility more robust.

CHAPTER 6: USEFUL HELP

6.1 DRIVER INSTALLATION NOTE

After you installed your operating system, please insert the Fully Setup Driver CD into your optical drive and install the driver for better system performance.

You will see the following window after you insert the CD

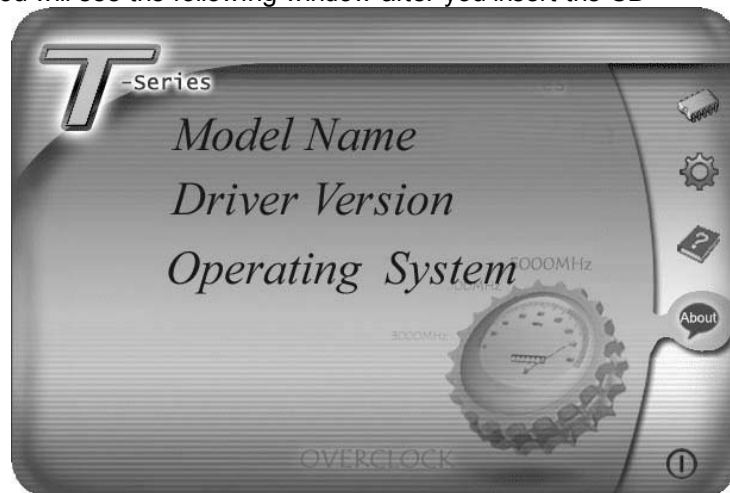

The setup guide will auto detect your motherboard and operating system.

Note:

If this window didn't show up after you insert the Driver CD, please use file browser to locate and execute the file **SETUP.EXE** under your optical drive.

A. Driver Installation

To install the driver, please click on the Driver icon. The setup guide will list the compatible driver for your motherboard and operating system. Click on each device driver to launch the installation program.

B. Software Installation

To install the software, please click on the Software icon. The setup guide will list the software available for your system, click on each software title to launch the installation program.

C. Manual

Aside from the paperback manual, we also provide manual in the Driver CD. Click on the Manual icon to browse for available manual.

Note:

You will need Acrobat Reader to open the manual file. Please download the latest version of Acrobat Reader software from <http://www.adobe.com/products/acrobat/readstep2.html>

6.2 AWARD BIOS BEEP CODE

Beep Sound	Meaning
One long beep followed by two short beeps	Video card not found or video card memory bad
High-low siren sound	CPU overheated System will shut down automatically
One Short beep when system boot-up	No error found during POST
Long beeps every other second	No DRAM detected or install

6.3 EXTRA INFORMATION

CPU Overheated

If the system shutdown automatically after power on system for seconds, that means the CPU protection function has been activated.

When the CPU is over heated, the motherboard will shutdown automatically to avoid a damage of the CPU, and the system may not power on again.

In this case, please double check:

1. The CPU cooler surface is placed evenly with the CPU surface.
2. CPU fan is rotated normally.
3. CPU fan speed is fulfilling with the CPU speed.

After confirmed, please follow steps below to relief the CPU protection function.

1. Remove the power cord from power supply for seconds.
2. Wait for seconds.
3. Plug in the power cord and boot up the system.

Or you can:

1. Clear the CMOS data.
(See "Close CMOS Header: JCMOS1" section)
2. Wait for seconds.
3. Power on the system again.

6.4 TROUBLESHOOTING

Probable	Solution
1. No power to the system at all Power light don't illuminate, fan inside power supply does not turn on. 2. Indicator light on keyboard does not turn on.	1. Make sure power cable is securely plugged in. 2. Replace cable. 3. Contact technical support.
System inoperative. Keyboard lights are on, power indicator lights are lit, and hard drive is spinning.	Using even pressure on both ends of the DIMM, press down firmly until the module snaps into place.
System does not boot from hard disk drive, can be booted from optical drive.	1. Check cable running from disk to disk controller board. Make sure both ends are securely plugged in; check the drive type in the standard CMOS setup. 2. Backing up the hard drive is extremely important. All hard disks are capable of breaking down at any time.
System only boots from optical drive. Hard disk can be read and applications can be used but booting from hard disk is impossible.	1. Back up data and applications files. 2. Reformat the hard drive. Re-install applications and data using backup disks.
Screen message says "Invalid Configuration" or "CMOS Failure."	Review system's equipment. Make sure correct information is in setup.
Cannot boot system after installing second hard drive.	1. Set master/slave jumpers correctly. 2. Run SETUP program and select correct drive types. Call the drive manufacturers for compatibility with other drives.

APPENDENCIES: SPEC IN OTHER LANGUAGE

GERMAN

	TF7150U-M7	TF7100P-M7
CPU	LGA 775 Intel Core2Duo / Core2Quad / Celeron 4xx / Pentium 4 / Pentium D Prozessoren Unterstützt 45nm CPU Unterstützt Hyper-Threading / Execute Disable Bit / Enhanced Intel SpeedStep® / Intel Architecture-64 / Extended Memory 64 Technology / Virtualization Technology	LGA 775 Intel Core2Duo / Core2Quad / Celeron 4xx / Pentium 4 / Pentium D Prozessoren Unterstützt 45nm CPU Unterstützt Hyper-Threading / Execute Disable Bit / Enhanced Intel SpeedStep® / Intel Architecture-64 / Extended Memory 64 Technology / Virtualization Technology
FSB	1333 MHz	1333 MHz
Chipsatz	GeForce 7150/nForce 630i	GeForce 7100/nForce 630i
Super E/A	ITE 8718F Bietet die häufig verwendeten alten Super E/A-Funktionen. Low Pin Count-Schnittstelle Umgebungskontrolle, Hardware-Überwachung Lüfterdrehzahl-Controller "Smart Guardian"-Funktion von ITE	ITE 8718F Bietet die häufig verwendeten alten Super E/A-Funktionen. Low Pin Count-Schnittstelle Umgebungskontrolle, Hardware-Überwachung Lüfterdrehzahl-Controller "Smart Guardian"-Funktion von ITE
Arbeitsspeicher	DDR2 DIMM-Steckplätze x 2 Max. 4GB Arbeitsspeicher Jeder DIMM unterstützt 512MB/1GB/2GB DDR2. Ein-Kanal DDR2 Speichermodul Unterstützt DDR2 533 / 667 / 800 registrierte DIMMs. ECC DIMMs werden nicht unterstützt.	DDR2 DIMM-Steckplätze x 2 Max. 4GB Arbeitsspeicher Jeder DIMM unterstützt 512MB/1GB/2GB DDR2. Ein-Kanal DDR2 Speichermodul Unterstützt DDR2 533 / 667 / 800 registrierte DIMMs. ECC DIMMs werden nicht unterstützt.
Grafik	GeForce 7150/nForce 630i Max. 512MB gemeinsam benutzter Videospeicher (under OS)	GeForce 7100/nForce 630i Max. 512MB gemeinsam benutzter Videospeicher (under OS)
IDE	Integrierter IDE-Controller Ultra DMA 33 / 66 / 100 / 133 Bus Master-Modus Unterstützt PIO-Modus 0~4,	Integrierter IDE-Controller Ultra DMA 33 / 66 / 100 / 133 Bus Master-Modus Unterstützt PIO-Modus 0~4,
SATA II	Integrierter Serial ATA-Controller Datentransferate bis zu 3Gb/s Konform mit der SATA-Spezifikation Version 2.0.	Integrierter Serial ATA-Controller Datentransferate bis zu 3Gb/s Konform mit der SATA-Spezifikation Version 2.0.
LAN	Realtek 8111B / 8111C(optional) 10 / 100 Mb/s und 1Gb/s Auto-Negotiation Halb-/ Voll duplex-Funktion	Realtek 8111B / 8111C(optional) 10 / 100 Mb/s und 1Gb/s Auto-Negotiation Halb-/ Voll duplex-Funktion

TF7150U-M7/TF7100P-M7

	TF7150U-M7	TF7100P-M7
Audio-Codec	ALC 888 / GeForce 7150 nForce 630i (HDMI audio) 7.1-Kanal-Audioausgabe (ALC888) 2-Kanal-Audioausgabe (HDMI Audio) Unterstützt High-Definition Audio	ALC 888 / GeForce 7100 nForce 630i (HDMI audio) 7.1-Kanal-Audioausgabe (ALC888) 2-Kanal-Audioausgabe (HDMI Audio) Unterstützt High-Definition Audio
Steckplätze	PCI-Steckplatz x2 PCI Express x16 Steckplatz x1 PCI Express x 1-Steckplatz x1	PCI-Steckplatz x2 PCI Express x16 Steckplatz x1 PCI Express x 1-Steckplatz x1
Onboard-Anschluss	Diskettenlaufwerkanschluss x1 Druckeranschluss Anschluss x1 IDE-Anschluss x1 SATA-Anschluss x4 Fronttafelanschluss x1 Front-Audioanschluss x1 CD-IN-Anschluss x1 S/PDIF- Ausgangsanschluss x1 CPU-Lüfter-Sockel x1 System-Lüfter-Sockel x2 "CMOS löschen"-Sockel x1 USB-Anschluss x3 Serieller Anschluss x1 Stromanschluss (24-polig) x1 Stromanschluss (4-polig) x1	Diskettenlaufwerkanschluss x1 Druckeranschluss Anschluss x1 IDE-Anschluss x1 SATA-Anschluss x4 Fronttafelanschluss x1 Front-Audioanschluss x1 CD-IN-Anschluss x1 S/PDIF- Ausgangsanschluss x1 CPU-Lüfter-Sockel x1 System-Lüfter-Sockel x2 "CMOS löschen"-Sockel x1 USB-Anschluss x3 Serieller Anschluss x1 Stromanschluss (24-polig) x1 Stromanschluss (4-polig) x1
Rückseiten-E/A	PS/2-Tastatur x1 HDMI-Anschluss x1 VGA-Anschluss x1 DVI-D-Anschluss x1 LAN-Anschluss x1 USB-Anschluss x4 Audioanschluss x6	PS/2-Tastatur x1 HDMI-Anschluss x1 VGA-Anschluss x1 DVI-D-Anschluss x1 LAN-Anschluss x1 USB-Anschluss x4 Audioanschluss x6
Platinengröße	244 mm (B) X 244 mm (L)	244 mm (B) X 244 mm (L)
Sonderfunktionen	Unterstützt RAID 0 / 1 / 5 / 0+1	Unterstützt RAID 0 / 1 / 5 / 0+1
OS-Unterstützung	Windows XP / VISTA Biostar behält sich das Recht vor, ohne Ankündigung die Unterstützung für ein Betriebssystem hinzuzufügen oder zu entfernen.	Windows XP / VISTA Biostar behält sich das Recht vor, ohne Ankündigung die Unterstützung für ein Betriebssystem hinzuzufügen oder zu entfernen.

FRANCE

	TF7150U-M7	TF7100P-M7
UC	LGA 775 Processeurs Intel Core2Duo / Core2Quad / Celeron 4xx / Pentium 4 / Pentium D Prend en charge le 45nm UC Prend en charge les technologies Hyper-Threading / d'exécution de bit de désactivation / Intel SpeedStep® optimisée/ d'architecture Intel 64 / de mémoire étendue 64 / de virtualisation	LGA 775 Processeurs Intel Core2Duo / Core2Quad / Celeron 4xx / Pentium 4 / Pentium D Prend en charge le 45nm UC Prend en charge les technologies Hyper-Threading / d'exécution de bit de désactivation / Intel SpeedStep® optimisée/ d'architecture Intel 64 / de mémoire étendue 64 / de virtualisation
Bus frontal	1333 MHz	1333 MHz
Chipset	GeForce 7150/nForce 630i	GeForce 7100/nForce 630i
Super E/S	ITE 8718F Fournit la fonctionnalité de Super E/S patrimoniales la plus utilisée. Interface à faible compte de broches Initiatives de contrôle environnementales, Moniteur de matériel Contrôleur de vitesse de ventilateur Fonction "Gardien intelligent" de l'ITE	ITE 8718F Fournit la fonctionnalité de Super E/S patrimoniales la plus utilisée. Interface à faible compte de broches Initiatives de contrôle environnementales, Moniteur de matériel Contrôleur de vitesse de ventilateur Fonction "Gardien intelligent" de l'ITE
Mémoire principale	Fentes DDR2 DIMM x 2 Capacité mémoire maximale de 4 Go Chaque DIMM prend en charge des DDR2 de 512Mo et 1Go/2Go Module de mémoire DDR2 à mode à simple voie Prend en charge la DDR2 533 / 667 / 800 Les DIMM à registres et DIMM avec code correcteurs d'erreurs ne sont pas prises en charge	Fentes DDR2 DIMM x 2 Capacité mémoire maximale de 4 Go Chaque DIMM prend en charge des DDR2 de 512Mo et 1Go/2Go Module de mémoire DDR2 à mode à simple voie Prend en charge la DDR2 533 / 667 / 800 Les DIMM à registres et DIMM avec code correcteurs d'erreurs ne sont pas prises en charge
Graphiques	GeForce 7150/nForce 630i Mémoire vidéo partagée maximale de 512 Mo (under OS)	GeForce 7100/nForce 630i Mémoire vidéo partagée maximale de 512 Mo (under OS)
IDE	Contrôleur IDE intégré Mode principale de Bus Ultra DMA 33 / 66 / 100 / 133 Prend en charge le mode PIO 0~4,	Contrôleur IDE intégré Mode principale de Bus Ultra DMA 33 / 66 / 100 / 133 Prend en charge le mode PIO 0~4,
SATA II	Contrôleur Serial ATA intégré : Taux de transfert jusqu'à 3 Go/s. Conforme à la spécification SATA Version 2.0	Contrôleur Serial ATA intégré : Taux de transfert jusqu'à 3 Go/s. Conforme à la spécification SATA Version 2.0
LAN	Realtek 8111B / 8111C(en option) 10 / 100 Mb/s et 1 Gb/s négociation automatique Half / Full duplex capability	Realtek 8111B / 8111C(en option) 10 / 100 Mb/s et 1 Gb/s négociation automatique Half / Full duplex capability

TF7150U-M7/TF7100P-M7

	TF7150U-M7	TF7100P-M7
Codec audio	ALC 888 / Intégré dans la GeForce 7150 nForce 630i (HDMI audio) Sortie audio à 7.1 voies (ALC888) Sortie audio à 2 voies (HDMI audio) Prise en charge de l'audio haute définition	ALC 888 / Intégré dans la GeForce 7100 nForce 630i (HDMI audio) Sortie audio à 7.1 voies (ALC888) Sortie audio à 2 voies (HDMI audio) Prise en charge de l'audio haute définition
Fentes	Fente PCI x2 Slot PCI Express x16 x1 Slot PCI Express x 1 x1	Fente PCI x2 Slot PCI Express x16 x1 Slot PCI Express x 1 x1
Connecteur embarqué	Connecteur de disquette x1 Connecteur de Port d'imprimante x1 Connecteur IDE x1 Connecteur SATA x4 Connecteur du panneau avant x1 Connecteur Audio du panneau avant x1 Connecteur d'entrée CD x1 Connecteur de sortie S/PDIF x1 Embase de ventilateur UC x1 Embase de ventilateur système x2 Embase d'effacement CMOS x1 Connecteur USB x3 Connecteur de Port série x1 Connecteur d'alimentation (24 broches) x1 Connecteur d'alimentation (4 broches) x1	Connecteur de disquette x1 Connecteur de Port d'imprimante x1 Connecteur IDE x1 Connecteur SATA x4 Connecteur du panneau avant x1 Connecteur Audio du panneau avant x1 Connecteur d'entrée CD x1 Connecteur de sortie S/PDIF x1 Embase de ventilateur UC x1 Embase de ventilateur système x2 Embase d'effacement CMOS x1 Connecteur USB x3 Connecteur de Port série x1 Connecteur d'alimentation (24 broches) x1 Connecteur d'alimentation (4 broches) x1
E/S du panneau arrière	Clavier PS/2 x1 Port HDMI x1 Port VGA x1 Port DVI-D x1 Port LAN x1 Port USB x4 Fiche audio x6	Clavier PS/2 x1 Port HDMI x1 Port VGA x1 Port DVI-D x1 Port LAN x1 Port USB x4 Fiche audio x6
Dimensions de la carte	244 mm (l) X 244 mm (H)	244 mm (l) X 244 mm (H)
Fonctionnalités spéciales	Prise en charge RAID 0 / 1 / 5 / 0+1	Prise en charge RAID 0 / 1 / 5 / 0+1
Support SE	Windows XP / VISTA Biostar se réserve le droit d'ajouter ou de supprimer le support de SE avec ou sans préavis.	Windows XP / VISTA Biostar se réserve le droit d'ajouter ou de supprimer le support de SE avec ou sans préavis.

ITALIAN

	TF7150U-M7	TF7100P-M7
CPU	LGA 775 Processore Intel Core2Duo / Core2Quad / Celeron 4xx / Pentium 4 / Pentium D Supporto 45nm CPU Supporto di Hyper-Threading / Execute Disable Bit / Enhanced Intel SpeedStep® / Architettura Intel 64 / Tecnologia Extended Memory 64 / Tecnologia Virtualization	LGA 775 Processore Intel Core2Duo / Core2Quad / Celeron 4xx / Pentium 4 / Pentium D Supporto 45nm CPU Supporto di Hyper-Threading / Execute Disable Bit / Enhanced Intel SpeedStep® / Architettura Intel 64 / Tecnologia Extended Memory 64 / Tecnologia Virtualization
FSB	1333 MHz	1333 MHz
Chipset	GeForce 7150/nForce 630i	GeForce 7100/nForce 630i
Super I/O	ITE 8718F Fornisce le funzionalità legacy Super I/O usate più comunemente. Interfaccia LPC (Low Pin Count) Funzioni di controllo dell'ambiente: Monitoraggio hardware Controller velocità ventolina Funzione "Smart Guardian" di ITE	ITE 8718F Fornisce le funzionalità legacy Super I/O usate più comunemente. Interfaccia LPC (Low Pin Count) Funzioni di controllo dell'ambiente: Monitoraggio hardware Controller velocità ventolina Funzione "Smart Guardian" di ITE
Memoria principale	Alloggi DIMM DDR2 x 2 Capacità massima della memoria 4GB Ciascun DIMM supporta DDR2 512MB e 1GB/2GB Modulo di memoria DDR2 a canale singolo Supporto di DDR2 533 / 667 / 800 DIMM registrati e DIMM ECC non sono supportati	Alloggi DIMM DDR2 x 2 Capacità massima della memoria 4GB Ciascun DIMM supporta DDR2 512MB e 1GB/2GB Modulo di memoria DDR2 a canale singolo Supporto di DDR2 533 / 667 / 800 DIMM registrati e DIMM ECC non sono supportati
Grafica	GeForce 7150/nForce 630i La memoria video condivisa massima è di 512MB (under OS)	GeForce 7100/nForce 630i La memoria video condivisa massima è di 512MB (under OS)
IDE	Controller IDE integrato Modalità Bus Master Ultra DMA 33 / 66 / 100 / 133 Supporto modalità PIO Mode 0-4	Controller IDE integrato Modalità Bus Master Ultra DMA 33 / 66 / 100 / 133 Supporto modalità PIO Mode 0-4
SATA II	Controller Serial ATA integrato Velocità di trasferimento dei dati fino a 3 Gb/s. Compatibile specifiche SATA Versione 2.0.	Controller Serial ATA integrato Velocità di trasferimento dei dati fino a 3 Gb/s. Compatibile specifiche SATA Versione 2.0.
LAN	Realtek 8111B / 8111C(optional) Negoziazione automatica 10 / 100 Mb/s e 1Gb/s Capacità Half / Full Duplex	Realtek 8111B / 8111C(optional) Negoziazione automatica 10 / 100 Mb/s e 1Gb/s Capacità Half / Full Duplex

TF7150U-M7/TF7100P-M7

	TF7150U-M7	TF7100P-M7
Codec audio	ALC 888 / Integrata nel GeForce 7150 nForce 630i (HDMI audio) Uscita audio 7.1 canali (ALC888) Uscita audio 2 canali (HDMI audio) Supporto audio High-Definition (HD)	ALC 888 / Integrata nel GeForce 7100 nForce 630i (HDMI audio) Uscita audio 7.1 canali (ALC888) Uscita audio 2 canali (HDMI audio) Supporto audio High-Definition (HD)
Alloggi	Alloggio PCI x2 Alloggio PCI Express x16 x1 Alloggio PCI Express x1 x1	Alloggio PCI x2 Alloggio PCI Express x16 x1 Alloggio PCI Express x1 x1
Connettori su scheda	Connettore floppy x1 Connettore Porta stampante x1 Connettore IDE x1 Connettore SATA x4 Connettore pannello frontale x1 Connettore audio frontale x1 Connettore CD-in x1 Connettore output SPDIF x1 Collettore ventolina CPU x1 Collettore ventolina CPU x1 Collettore ventolina sistema x2 Collettore cancellazione CMOS x1 Connettore USB x3 Connettore Porta seriale x1 Connettore alimentazione (24 pin) x1 Connettore alimentazione (4 pin) x1	Connettore floppy x1 Connettore Porta stampante x1 Connettore IDE x1 Connettore SATA x4 Connettore pannello frontale x1 Connettore audio frontale x1 Connettore CD-in x1 Connettore output SPDIF x1 Collettore ventolina CPU x1 Collettore ventolina CPU x1 Collettore ventolina sistema x2 Collettore cancellazione CMOS x1 Connettore USB x3 Connettore Porta seriale x1 Connettore alimentazione (24 pin) x1 Connettore alimentazione (4 pin) x1
I/O pannello posteriore	Tastiera PS/2 x1 Porta HDMI x1 Porta VGA x1 Porta DVI-D x1 Porta LAN x1 Porta USB x4 Connettore audio x6	Tastiera PS/2 x1 Porta HDMI x1 Porta VGA x1 Porta DVI-D x1 Porta LAN x1 Porta USB x4 Connettore audio x6
Dimensioni scheda	244 mm (larghezza) x 244 mm (altezza)	244 mm (larghezza) x 244 mm (altezza)
Caratteristiche speciali	Supporto RAID 0 / 1 / 5 / 0+1	Supporto RAID 0 / 1 / 5 / 0+1
Sistemi operativi supportati	Windows XP / VISTA Biostar si riserva il diritto di aggiungere o rimuovere il supporto di qualsiasi sistema operativo senza preavviso.	Windows XP / VISTA Biostar si riserva il diritto di aggiungere o rimuovere il supporto di qualsiasi sistema operativo senza preavviso.

SPANISH

	TF7150U-M7	TF7100P-M7
CPU	LGA 775 Procesador Intel Core2Duo / Core2Quad / Celeron 4xx / Pentium 4 / Pentium D Admite 45nm CPU Admite Hyper-Threading / Bit de deshabilitación de ejecución / Intel SpeedStep® Mejorado / Intel Architecture-64 / Tecnología Extended Memory 64 / Tecnología de virtualización	LGA 775 Procesador Intel Core2Duo / Core2Quad / Celeron 4xx / Pentium 4 / Pentium D Admite 45nm CPU Admite Hyper-Threading / Bit de deshabilitación de ejecución / Intel SpeedStep® Mejorado / Intel Architecture-64 / Tecnología Extended Memory 64 / Tecnología de virtualización
FSB	1333 MHz	1333 MHz
Conjunto de chips	GeForce 7150/nForce 630i	GeForce 7100/nForce 630i
Súper E/S	ITE 8718F Le ofrece las funcionalidades heredadas de uso más común Súper E/S. Interfaz de cuenta Low Pin Iniciativas de control de entorno, Monitor hardware Controlador de velocidad de ventilador Función "Guardia inteligente" de ITE	ITE 8718F Le ofrece las funcionalidades heredadas de uso más común Súper E/S. Interfaz de cuenta Low Pin Iniciativas de control de entorno, Monitor hardware Controlador de velocidad de ventilador Función "Guardia inteligente" de ITE
Memoria principal	Ranuras DIMM DDR2 x 2 Capacidad máxima de memoria de 4GB Cada DIMM admite DDR de 512MB y 1GB/2GB Módulo de memoria DDR2 de canal Sencillo Admite DDR2 de 533 / 667 / 800 No admite DIMM registrados o DIMM compatibles con ECC	Ranuras DIMM DDR2 x 2 Capacidad máxima de memoria de 4GB Cada DIMM admite DDR de 512MB y 1GB/2GB Módulo de memoria DDR2 de canal Sencillo Admite DDR2 de 533 / 667 / 800 No admite DIMM registrados o DIMM compatibles con ECC
Gráficos	GeForce 7150/nForce 630i Memoria máxima de vídeo compartida de 512MB (under OS)	GeForce 7100/nForce 630i Memoria máxima de vídeo compartida de 512MB (under OS)
IDE	Controlador IDE integrado Modo bus maestro Ultra DMA 33 / 66 / 100 / 133 Soporte los Modos PIO 0~4,	Controlador IDE integrado Modo bus maestro Ultra DMA 33 / 66 / 100 / 133 Soporte los Modos PIO 0~4,
SATA II	Controlador ATA Serie Integrado Tasas de transferencia de hasta 3 Gb/s. Compatible con la versión SATA 2.0.	Controlador ATA Serie Integrado Tasas de transferencia de hasta 3 Gb/s. Compatible con la versión SATA 2.0.
Red Local	Realtek 8111B / 8111C(opcional) Negociación de 10 / 100 Mb/s y 1 Gb/s Funciones Half / Full dúplex	Realtek 8111B / 8111C(opcional) Negociación de 10 / 100 Mb/s y 1 Gb/s Funciones Half / Full dúplex

TF7150U-M7/TF7100P-M7

	TF7150U-M7		TF7100P-M7	
Códecs de sonido	ALC 888 / Integrados en el conjunto de GeForce 7150 nForce 630i (HDMI sonido) Salida de sonido de 7.1 canales (ALC888) Salida de sonido de 2 canales (HDMI sonido) Soporte de sonido Alta Definición		ALC 888 / Integrados en el conjunto de GeForce 7100 nForce 630i (HDMI sonido) Salida de sonido de 7.1 canales (ALC888) Salida de sonido de 2 canales (HDMI sonido) Soporte de sonido Alta Definición	
Ranuras	Ranura PCI	X2	Ranura PCI	X2
	Ranura PCI Express x16	X1	Ranura PCI Express x16	X1
	Ranura PCI express x 1	X1	Ranura PCI express x 1	X1
Conectores en placa	Conector disco flexible	X1	Conector disco flexible	X1
	Conector Puerto de impresora	X1	Conector Puerto de impresora	X1
	Conector IDE	X1	Conector IDE	X1
	Conector SATA	X4	Conector SATA	X4
	Conector de panel frontal	X1	Conector de panel frontal	X1
	Conector de sonido frontal	X1	Conector de sonido frontal	X1
	Conector de entrada de CD	X1	Conector de entrada de CD	X1
	Conector de salida S/PDIF	X1	Conector de salida S/PDIF	X1
	Cabecera de ventilador de CPU	X1	Cabecera de ventilador de CPU	X1
	Cabecera de ventilador de sistema	X2	Cabecera de ventilador de sistema	X2
	Cabecera de borrado de CMOS	X1	Cabecera de borrado de CMOS	X1
	Conector USB	X3	Conector USB	X3
	Conector Puerto serie	X1	Conector Puerto serie	X1
	Conector de alimentación (24 patillas)	X1	Conector de alimentación (24 patillas)	X1
	Conector de alimentación (4 patillas)	X1	Conector de alimentación (4 patillas)	X1
Panel trasero de E/S	Teclado PS/2	X1	Teclado PS/2	X1
	Puerto HDMI	X1	Puerto HDMI	X1
	Puerto VGA	X1	Puerto VGA	X1
	Puerto DVI-D	X1	Puerto DVI-D	X1
	Puerto de red local	X1	Puerto de red local	X1
	Puerto USB	X4	Puerto USB	X4
	Conector de sonido	X6	Conector de sonido	X6
Tamaño de la placa	244 mm. (A) X 244 Mm. (H)		244 mm. (A) X 244 Mm. (H)	
Funciones especiales	Admite RAID 0 / 1 / 5 / 0+1		Admite RAID 0 / 1 / 5 / 0+1	
Soporte de sistema operativo	Windows XP / VISTA Biostar se reserva el derecho de añadir o retirar el soporte de cualquier SO con o sin aviso previo.		Windows XP / VISTA Biostar se reserva el derecho de añadir o retirar el soporte de cualquier SO con o sin aviso previo.	

PORTUGUESE

	TF7150U-M7	TF7100P-M7
CPU	LGA 775 Processador Intel Core2Duo / Core2Quad / Celeron 4xx / Pentium 4 / Pentium D Suporta 45nm CPU Suporta as tecnologias Hyper-Threading / Execute Disable Bit / Enhanced Intel SpeedStep® / Intel Architecture -64 / Extended Memory 64 / Virtualization	LGA 775 Processador Intel Core2Duo / Core2Quad / Celeron 4xx / Pentium 4 / Pentium D Suporta 45nm CPU Suporta as tecnologias Hyper-Threading / Execute Disable Bit / Enhanced Intel SpeedStep® / Intel Architecture -64 / Extended Memory 64 / Virtualization
FSB	1333 MHz	1333 MHz
Chipset	GeForce 7150/nForce 630i	GeForce 7100/nForce 630i
Especificação do Super I/O	ITE 8718F Proporciona as funcionalidades mais utilizadas em termos da especificação Super I/O. Interface LPC (Low Pin Count). Iniciativas para controlo do ambiente Monitorização do hardware Controlador da velocidade da ventoinha Função "Smart Guardian" da ITE	ITE 8718F Proporciona as funcionalidades mais utilizadas em termos da especificação Super I/O. Interface LPC (Low Pin Count). Iniciativas para controlo do ambiente Monitorização do hardware Controlador da velocidade da ventoinha Função "Smart Guardian" da ITE
Memória principal	Ranuras DIMM DDR2 x 2 Capacidade máxima de memória: 4 GB Cada módulo DIMM suporta uma memória DDR2 de 512 MB & 1 GB/2 GB Módulo de memória DDR2 de canal simples Suporta módulos DDR2 533 / 667 / 800 Os módulos DIMM registados e os DIMM ECC não são suportados	Ranuras DIMM DDR2 x 2 Capacidade máxima de memória: 4 GB Cada módulo DIMM suporta uma memória DDR2 de 512 MB & 1 GB/2 GB Módulo de memória DDR2 de canal simples Suporta módulos DDR2 533 / 667 / 800 Os módulos DIMM registados e os DIMM ECC não são suportados
Placa gráfica	GeForce 7150/nForce 630i Memória de vídeo máxima partilhada: 512 MB (under OS)	GeForce 7100/nForce 630i Memória de vídeo máxima partilhada: 512 MB (under OS)
IDE	Controlador IDE integrado Modo Bus master Ultra DMA 33 / 66 / 100 / 133 Suporta o modo PIO 0~4,	Controlador IDE integrado Modo Bus master Ultra DMA 33 / 66 / 100 / 133 Suporta o modo PIO 0~4,
SATA II	Controlador Serial ATA integrado Velocidades de transmissão de dados até 3 Gb/s. Compatibilidade com a especificação SATA versão 2.0.	Controlador Serial ATA integrado Velocidades de transmissão de dados até 3 Gb/s. Compatibilidade com a especificação SATA versão 2.0.
LAN	Realtek 8111B / 8111C(opcional) Auto negociação de 10 / 100 Mb/s e 1Gb/s Capacidade semi/full-duplex	Realtek 8111B / 8111C(opcional) Auto negociação de 10 / 100 Mb/s e 1Gb/s Capacidade semi/full-duplex

TF7150U-M7/TF7100P-M7

	TF7150U-M7	TF7100P-M7
Codec de som	ALC 888 / Integrada no GeForce 7150 nForce 630i (HDMI áudio) Saída de áudio de 7.1 canais (ALC888) Saída de áudio de 2 canais (HDMI áudio) Suporta a especificação High-Definition Audio	ALC 888 / Integrada no GeForce 7100 nForce 630i (HDMI áudio) Saída de áudio de 7.1 canais (ALC888) Saída de áudio de 2 canais (HDMI áudio) Suporta a especificação High-Definition Audio
Ranhuras	Ranhura PCI x2 Ranhura PCI Express x16 x1 Ranhura PCI Express x 1 x1	Ranhura PCI x2 Ranhura PCI Express x16 x1 Ranhura PCI Express x 1 x1
Conectores na placa	Conector da unidade de disquetes x1 Conector da para impressora x1 Conector IDE x1 Conector SATA x4 Conector do painel frontal x1 Conector de áudio frontal x1 Conector para entrada de CDs x1 Conector de saída S/PDIF x1 Conector da ventoinha da CPU x1 Conector da ventoinha do sistema x2 Conector para limpeza do CMOS x1 Conector USB x3 Conector da Porta série x1 Conector de alimentação (24 pinos) x1 Conector de alimentação (4 pinos) x1	Conector da unidade de disquetes x1 Conector da para impressora x1 Conector IDE x1 Conector SATA x4 Conector do painel frontal x1 Conector de áudio frontal x1 Conector para entrada de CDs x1 Conector de saída S/PDIF x1 Conector da ventoinha da CPU x1 Conector da ventoinha do sistema x2 Conector para limpeza do CMOS x1 Conector USB x3 Conector da Porta série x1 Conector de alimentação (24 pinos) x1 Conector de alimentação (4 pinos) x1
Entradas/Saídas no painel traseiro	Teclado PS/2 x1 Porta HDMI x1 Porta VGA x1 Porta DVI-D x1 Porta LAN x1 Porta USB x4 Tomada de áudio x6	Teclado PS/2 x1 Porta HDMI x1 Porta VGA x1 Porta DVI-D x1 Porta LAN x1 Porta USB x4 Tomada de áudio x6
Tamanho da placa	244 mm (L) X 244 mm (A)	244 mm (L) X 244 mm (A)
Características especiais	Suporta as funções RAID 0 / 1 / 5 / 0+1	Suporta as funções RAID 0 / 1 / 5 / 0+1
Sistemas operativos suportados	Windows XP / VISTA A Biostar reserva-se o direito de adicionar ou remover suporte para qualquer sistema operativo com ou sem aviso prévio.	Windows XP / VISTA A Biostar reserva-se o direito de adicionar ou remover suporte para qualquer sistema operativo com ou sem aviso prévio.

POLISH

	TF7150U-M7	TF7100P-M7
Procesor	LGA 775 Procesor Intel Core2Duo / Core2Quad / Celeron 4xx / Pentium 4 / Pentium D Obsługa 45nm Procesor Obsługa Hyper-Threading / Execute Disable Bit / Enhanced Intel SpeedStep® / Intel Architecture-64 / Extended Memory 64 Technology / Virtualization Technology	LGA 775 Procesor Intel Core2Duo / Core2Quad / Celeron 4xx / Pentium 4 / Pentium D Obsługa 45nm Procesor Obsługa Hyper-Threading / Execute Disable Bit / Enhanced Intel SpeedStep® / Intel Architecture-64 / Extended Memory 64 Technology / Virtualization Technology
FSB	1333 MHz	1333 MHz
Chipset	GeForce 7150/nForce 630i	GeForce 7100/nForce 630i
Pamięć główna	Gniazda DDR2 DIMM x 2 Maks. wielkość pamięci 4GB Każde gniazdo DIMM obsługuje moduły 512MB oraz 1GB/2GB DDR2 Moduł pamięci DDR2 z trybem pojedynczego kanału Obsługa DDR2 533 / 667 / 800 Brak obsługi Registered DIMM oraz ECC DIMM	Gniazda DDR2 DIMM x 2 Maks. wielkość pamięci 4GB Każde gniazdo DIMM obsługuje moduły 512MB oraz 1GB/2GB DDR2 Moduł pamięci DDR2 z trybem pojedynczego kanału Obsługa DDR2 533 / 667 / 800 Brak obsługi Registered DIMM oraz ECC DIMM
Super I/O	ITE 8718F Zapewnia najbardziej powszechne funkcje Super I/O. Interfejs Low Pin Count Funkcje kontroli warunków pracy, Monitor H/W Kontroler prędkości wentylatora Funkcja ITE "Smart Guardian"	ITE 8718F Zapewnia najbardziej powszechne funkcje Super I/O. Interfejs Low Pin Count Funkcje kontroli warunków pracy, Monitor H/W Kontroler prędkości wentylatora Funkcja ITE "Smart Guardian"
Grafika	GeForce 7150/nForce 630i Maks. wielkość współdzielonej pamięci video wynosi 512MB (under OS)	GeForce 7100/nForce 630i Maks. wielkość współdzielonej pamięci video wynosi 512MB (under OS)
IDE	Zintegrowany kontroler IDE Ultra DMA 33 / 66 / 100 / 133 Tryb Bus Master obsługa PIO tryb 0~4,	Zintegrowany kontroler IDE Ultra DMA 33 / 66 / 100 / 133 Tryb Bus Master obsługa PIO tryb 0~4,
SATA II	Zintegrowany kontroler Serial ATA Transfer danych do 3 Gb/s. Zgodność ze specyfikacją SATA w wersji 2.0.	Zintegrowany kontroler Serial ATA Transfer danych do 3 Gb/s. Zgodność ze specyfikacją SATA w wersji 2.0.
LAN	Realtek 8111B / 8111C(opcja) 10 / 100 Mb/s oraz 1Gb/s z automatyczną negocjacją szybkości Działanie w trybie półwicznego / pełnego dupleksu	Realtek 8111B / 8111C(opcja) 10 / 100 Mb/s oraz 1Gb/s z automatyczną negocjacją szybkości Działanie w trybie półwicznego / pełnego dupleksu

TF7150U-M7/TF7100P-M7

	TF7150U-M7	TF7100P-M7
Kodek dźwiękowy	ALC 888 / Zintegrowana w GeForce 7150 nForce 630i (HDMI audio) 7.1 kanałowe wyjście audio (ALC888) 2 kanałowe wyjście audio (HDMI audio) Obsługa High-Definition Audio	ALC 888 / Zintegrowana w GeForce 7100 nForce 630i (HDMI audio) 7.1 kanałowe wyjście audio (ALC888) 2 kanałowe wyjście audio (HDMI audio) Obsługa High-Definition Audio
Gniazda	Gniazdo PCI x2 Gniazdo PCI Express x16 x1 Gniazdo PCI Express x 1 x1	Gniazdo PCI x2 Gniazdo PCI Express x16 x1 Gniazdo PCI Express x 1 x1
Złącza wbudowane	Złącze napędu dyskietek x1 Złącze Port drukarki x1 Złącze IDE x1 Złącze SATA x4 Złącze panela przedniego x1 Przednie złącze audio x1 Złącze wejścia CD x1 Złącze wyjścia S/PDIF x1 Złącze główkowe wentylatora procesora x1 Złącze główkowe wentylatora systemowego x2 Złącze główkowe kasowania CMOS x1 Złącze USB x3 Złącze Port szeregowy x1 Złącze zasilania (24 pinowe) x1 Złącze zasilania (4 pinowe) x1	Złącze napędu dyskietek x1 Złącze Port drukarki x1 Złącze IDE x1 Złącze SATA x4 Złącze panela przedniego x1 Przednie złącze audio x1 Złącze wejścia CD x1 Złącze wyjścia S/PDIF x1 Złącze główkowe wentylatora procesora x1 Złącze główkowe wentylatora systemowego x2 Złącze główkowe kasowania CMOS x1 Złącze USB x3 Złącze Port szeregowy x1 Złącze zasilania (24 pinowe) x1 Złącze zasilania (4 pinowe) x1
Back Panel I/O	Klawiatura PS/2 x1 Port HDMI x1 Port VGA x1 Port DVI-D x1 Port LAN x1 Port USB x4 Gniazdo audio x6	Klawiatura PS/2 x1 Port HDMI x1 Port VGA x1 Port DVI-D x1 Port LAN x1 Port USB x4 Gniazdo audio x6
Wymiary płyty	244 mm (S) X 244 mm (W)	244 mm (S) X 244 mm (W)
Funkcje specjalne	Obsługa RAID 0 / 1 / 5 / 0+1	Obsługa RAID 0 / 1 / 5 / 0+1
Obsługa systemu operacyjnego	Windows XP / VISTA Biostar zastrzega sobie prawo dodawania lub odwoływania obsługi dowolnego systemu operacyjnego bez powiadomienia.	Windows XP / VISTA Biostar zastrzega sobie prawo dodawania lub odwoływania obsługi dowolnego systemu operacyjnego bez powiadomienia.

RUSSIAN

	TF7150U-M7	TF7100P-M7
CPU (центральный процессор)	LGA 775 Процессор Intel Core2Duo / Core2Quad / Celeron 4xx / Pentium 4 / Pentium D Поддержка технологий 45nm CPU Поддержка технологий Hyper-Threading / Execute Disable Bit / Enhanced Intel SpeedStep® / Intel Architecture-64 / Extended Memory 64 Technology / технологии виртуализация	LGA 775 Процессор Intel Core2Duo / Core2Quad / Celeron 4xx / Pentium 4 / Pentium D Поддержка технологий 45nm CPU Поддержка технологий Hyper-Threading / Execute Disable Bit / Enhanced Intel SpeedStep® / Intel Architecture-64 / Extended Memory 64 Technology / технологии виртуализация
FSB	1333 МГц	1333 МГц
Набор микросхем	GeForce 7150/nForce 630i	GeForce 7100/nForce 630i
Основная память	Слоты DDR2 DIMM x 2 Максимальная ёмкость памяти 4 ГБ Каждый модуль DIMM поддерживает 512МБ & 1ГБ/2ГБ DDR2 Модуль памяти с одноканальным режимом DDR2 Поддержка DDR2 533 / 667 / 800 Не поддерживает зарегистрированные модули DIMM and ECC DIMM	Слоты DDR2 DIMM x 2 Максимальная ёмкость памяти 4 ГБ Каждый модуль DIMM поддерживает 512МБ & 1ГБ/2ГБ DDR2 Модуль памяти с одноканальным режимом DDR2 Поддержка DDR2 533 / 667 / 800 Не поддерживает зарегистрированные модули DIMM and ECC DIMM
Super I/O	ITE 8718F Обеспечивает наиболее используемые действующие функциональные возможности Super I/O. Интерфейс с низким количеством выводов Инициативы по охране окружающей среды, Аппаратный монитор Регулятор скорости Функция ITE "Smart Guardian" (Интеллектуальная защита)	ITE 8718F Обеспечивает наиболее используемые действующие функциональные возможности Super I/O. Интерфейс с низким количеством выводов Инициативы по охране окружающей среды, Аппаратный монитор Регулятор скорости Функция ITE "Smart Guardian" (Интеллектуальная защита)
Графика	GeForce 7150/nForce 630i Максимальная совместно используемая видео память составляет 512 МБ (under OS)	GeForce 7100/nForce 630i Максимальная совместно используемая видео память составляет 512 МБ (under OS)
IDE	Встроенное устройство управления встроенными интерфейсами устройств Режим "хозяина" шины Ultra DMA 33 / 66 / 100 / 133 Поддержка режима PIO 0~4,	Встроенное устройство управления встроенными интерфейсами устройств Режим "хозяина" шины Ultra DMA 33 / 66 / 100 / 133 Поддержка режима PIO 0~4,
SATA II	Встроенное последовательное устройство управления ATA скорость передачи данных до 3 гигабит/с. Соответствие спецификации SATA версия 2.0.	Встроенное последовательное устройство управления ATA скорость передачи данных до 3 гигабит/с. Соответствие спецификации SATA версия 2.0.
Локальная сеть	Realtek 8111B / 8111C(дополнительно) Автоматическое согласование 10 / 100 Мб/с и 1Гб/с Частичная / полная дуплексная способность	Realtek 8111B / 8111C(дополнительно) Автоматическое согласование 10 / 100 Мб/с и 1Гб/с Частичная / полная дуплексная способность

TF7150U-M7/TF7100P-M7

	TF7150U-M7		TF7100P-M7	
Звуковой кодек	ALC888 / Встроенная в набор микросхем GeForce 7150 nForce 630i (HDMI) Звуковая поддержка High-Definition 7.1канальный звуковой выход (ALC888) 2канальный звуковой выход (HDMI)		ALC888 / Встроенная в набор микросхем GeForce 7100 nForce 630i (HDMI) Звуковая поддержка High-Definition 7.1канальный звуковой выход (ALC888) 2канальный звуковой выход (HDMI)	
Слоты	Слот PCI	x2	Слот PCI	x2
	Слот PCI Express x16	x1	Слот PCI Express x16	x1
	Слот PCI Express x 1	x1	Слот PCI Express x 1	x1
Встроенный разъём	Разъём НГМД	x1	Разъём НГМД	x1
	Разъём Порт подключения принтера	x1	Разъём Порт подключения принтера	x1
	Разъём IDE	x1	Разъём IDE	x1
	Разъём SATA	x4	Разъём SATA	x4
	Разъём на лицевой панели	x1	Разъём на лицевой панели	x1
	Входной звуковой разъём	x1	Входной звуковой разъём	x1
	Разъём ввода для CD	x1	Разъём ввода для CD	x1
	Разъём вывода для S/PDIF	x1	Разъём вывода для S/PDIF	x1
	Контактирующее приспособление вентилятора центрального процессора	x1	Контактирующее приспособление вентилятора центрального процессора	x1
	Контактирующее приспособление вентилятора системы	x2	Контактирующее приспособление вентилятора системы	x2
	Открытое контактирующее приспособление CMOS	x1	Открытое контактирующее приспособление CMOS	x1
	USB-разъём	x3	USB-разъём	x3
	Разъём Последовательный порт	x1	Разъём Последовательный порт	x1
	Разъем питания (24 вывод)	x1	Разъем питания (24 вывод)	x1
Разъем питания (4 вывод)	x1	Разъем питания (4 вывод)	x1	
Задняя панель средств ввода-вывода	Клавиатура PS/2	x1	Клавиатура PS/2	x1
	Порт HDMI	x1	Порт HDMI	x1
	Порт VGA	x1	Порт VGA	x1
	Порт DVI-D	x1	Порт DVI-D	x1
	Порт LAN	x1	Порт LAN	x1
	USB-порт	x4	USB-порт	x4
	Гнездо для подключения наушников	x6	Гнездо для подключения наушников	x6
Размер панели	244 мм (Ш) X 244 мм (В)		244 мм (Ш) X 244 мм (В)	
Специальные технические характеристики	Поддержка RAID 0 / 1 / 5 / 0+1		Поддержка RAID 0 / 1 / 5 / 0+1	
Поддержка OS	Windows XP / VISTA Biostar сохраняет за собой право добавлять или удалять средства обеспечения для OS с или без предварительного уведомления.		Windows XP / VISTA Biostar сохраняет за собой право добавлять или удалять средства обеспечения для OS с или без предварительного уведомления.	

ARABIC

TF7100P-M7	TF7150U-M7	
LGA 775 Intel Core2Duo / Core2Quad / Celeron 4xx معالجات يتردد يصل إلى Pentium 4 / Pentium D 45nm CPU تدعم تقنيات Hyper-Threading / Execute Disable Bit / Enhanced Intel SpeedStep® / Intel Architecture-64 / Extended Memory 64 Technology / Virtualization Technology	LGA 775 Intel Core2Duo / Core2Quad / Celeron 4xx معالجات يتردد يصل إلى Pentium 4 / Pentium D 45nm CPU تدعم تقنيات Hyper-Threading / Execute Disable Bit / Enhanced Intel SpeedStep® / Intel Architecture-64 / Extended Memory 64 Technology / Virtualization Technology	وحدة المعالجة المركزية
ميغا هرتز 1333 تردد	ميغا هرتز 1333 تردد	النقل الأممي الجانبي
GeForce 7100/nForce 630i	GeForce 7150/nForce 630i	مجموعة الشرائح
عدد 2 قناة DDR2 DIMM سعة ذاكرة قصوى 4 جيجا بايت ميغا بايت 512 سعة DDR2 تدعم ذاكرة من نوع DIMM تدعم كل قناة و 2/1 جيجا بايت أحادية القناة DDR2 وحدة ذاكرة سعت 800 / 667 / 533 ميغا بايت تدعم الذاكرة من نوع ECC وتلك التي لا تتوافق مع DIMM لا تدعم رقائق الذاكرة	عدد 2 قناة DDR2 DIMM سعة ذاكرة قصوى 4 جيجا بايت ميغا بايت 512 سعة DDR2 تدعم ذاكرة من نوع DIMM تدعم كل قناة و 2/1 جيجا بايت أحادية القناة DDR2 وحدة ذاكرة سعت 800 / 667 / 533 ميغا بايت تدعم الذاكرة من نوع ECC وتلك التي لا تتوافق مع DIMM لا تدعم رقائق الذاكرة	الذاكرة الرئيسية
ITE 8718F الأكثر استخداماً، Super I/O يوفر وظيفة Low Pin Count Interface تدعم تقنية وسائل التحكم في البيئة: مراقب لمعرفة حالة الأجهزة مراقب في سرعة المروحة من ITE "Smart Guardian" وظيفة	ITE 8718F الأكثر استخداماً، Super I/O يوفر وظيفة Low Pin Count Interface تدعم تقنية وسائل التحكم في البيئة: مراقب لمعرفة حالة الأجهزة مراقب في سرعة المروحة من ITE "Smart Guardian" وظيفة	Super I/O
GeForce 7100/nForce 630i (under OS) ميغا بايت 512 أقصى سعة لذاكرة الفيديو المشتركة	GeForce 7150/nForce 630i (under OS) ميغا بايت 512 أقصى سعة لذاكرة الفيديو المشتركة	بطاقة الرسومات
متكامل IDE متحكم وضع رئيسي 133 / 100 / 66 / 33 Ultra DMA نقل بتقنية PIO Mode 0 ~ 4 دعم وضع	متكامل IDE متحكم وضع رئيسي 133 / 100 / 66 / 33 Ultra DMA نقل بتقنية PIO Mode 0 ~ 4 دعم وضع	منفذ IDE
متكامل Serial ATA متحكم نقل البيانات بسرعة تصل إلى 3 جيجابت/ثانية. 2.0 الإصدار SATA مطابقة لمواصفات	متكامل Serial ATA متحكم نقل البيانات بسرعة تصل إلى 3 جيجابت/ثانية. 2.0 الإصدار SATA مطابقة لمواصفات	SATA II
Realtek 8111B / 8111C (اختياري) تفاوض تلقائي 100/10 ميغا بايت / ثانية و 1 جيجا بايت/ثانية إمكانية النقل المزدوج الكامل/القصفي	Realtek 8111B / 8111C (اختياري) تفاوض تلقائي 100/10 ميغا بايت / ثانية و 1 جيجا بايت/ثانية إمكانية النقل المزدوج الكامل/القصفي	شبكة داخلية

TF7150U-M7/TF7100P-M7

TF7100P-M7		TF7150U-M7		
ALC888 / GeForce 7100 nForce 630i (HDMI) مدمجة في رقاقة قوات لخرج الصوت 7.1 (ALC888) قوات لخرج الصوت 2 (HDMI) تدعم تقنية الصوت عالي التعريف من		ALC888 / GeForce 7150 nForce 630i (HDMI) مدمجة في رقاقة قوات لخرج الصوت 7.1 (ALC888) قوات لخرج الصوت 2 (HDMI) تدعم تقنية الصوت عالي التعريف من		كورتيك الصوت
عدد 2 عدد 1 عدد 1	قناة PCI قناة PCI Express x16 قناة PCI Express x1	عدد 2 عدد 1 عدد 1	قناة PCI قناة PCI Express x16 قناة PCI Express x1	التحات
عدد 1 عدد 1 عدد 1 عدد 4 عدد 1 عدد 1 عدد 1 عدد 1 عدد 1 عدد 1 عدد 2 عدد 1 عدد 3 عدد 1 عدد 1 عدد 1	منفذ محرك أقراص مرنة منفذ طباعة منفذ IDE منفذ SATA منفذ اللوحة الأملية منفذ الصوت الأملي منفذ CD-IN منفذ خرج S/PDIF وصلة مروحة وحدة المعالجة المركزية وصلة مروحة النظام وصلة مسح CMOS منفذ USB منفذ تسلسلي منفذ توصيل الطاقة (24دبوس) منفذ توصيل الطاقة (4دبليس)	عدد 1 عدد 1 عدد 1 عدد 4 عدد 1 عدد 1 عدد 1 عدد 1 عدد 1 عدد 1 عدد 2 عدد 1 عدد 3 عدد 1 عدد 1 عدد 1	منفذ محرك أقراص مرنة منفذ طباعة منفذ IDE منفذ SATA منفذ اللوحة الأملية منفذ الصوت الأملي منفذ CD-IN منفذ خرج S/PDIF وصلة مروحة وحدة المعالجة المركزية وصلة مروحة النظام وصلة مسح CMOS منفذ USB منفذ تسلسلي منفذ توصيل الطاقة (24دبوس) منفذ توصيل الطاقة (4دبليس)	المنفذ على سطح اللوحة
عدد 1 عدد 1 عدد 1 عدد 1 عدد 1 عدد 4 عدد 6	لوحة مفاتيح PS/2 منافذ HDMI منافذ VGA منافذ DVI-D منفذ شبكة اتصال محلية منافذ USB مقيس صوت	عدد 1 عدد 1 عدد 1 عدد 1 عدد 1 عدد 4 عدد 6	لوحة مفاتيح PS/2 منافذ HDMI منافذ VGA منافذ DVI-D منفذ شبكة اتصال محلية منافذ USB مقيس صوت	منفذ دخل/مخرج اللوحة الخلفية
RAID 0 / 1 / 5 / 0+1 تدعم تقنية		RAID 0 / 1 / 5 / 0+1 تدعم تقنية		مزيا خاصة
244 مم (عرض) 244 X مم (ارتفاع)		244 مم (عرض) 244 X مم (ارتفاع)		حجم اللوحة
Windows XP / VISTA بحقها في اضافة أو إزالة الدعم لأي نظام تشغيل باخطار أو Biostar تحتفظ بدون إخطار .		Windows XP / VISTA بحقها في اضافة أو إزالة الدعم لأي نظام تشغيل باخطار أو Biostar تحتفظ بدون إخطار .		دعم أنظمة التشغيل

JAPANESE

	TF7150U-M7	TF7100P-M7
CPU	LGA 775 Intel Core2Duo / Core2Quad / Celeron 4xx / Pentium 4 / Pentium D processor 45nm CPU をサポートします Hyper-Threading / Execute Disable Bit / Enhanced Intel SpeedStep® / Intel Architecture-64 / Extended Memory 64 Technology / Virtualization Technologyをサポート します	LGA 775 Intel Core2Duo / Core2Quad / Celeron 4xx / Pentium 4 / Pentium D processor 45nm CPU をサポートします Hyper-Threading / Execute Disable Bit / Enhanced Intel SpeedStep® / Intel Architecture-64 / Extended Memory 64 Technology / Virtualization Technologyをサポート します
FSB	1333 MHz	1333 MHz
チップセット	GeForce 7150/nForce 630i	GeForce 7100/nForce 630i
メインメモリ	DDR2 DIMMスロット x 2 最大メモリ容量 4GB 各DIMMは512MB/1GB/2GB DDR2をサポート シングル チャンネルモードDDR2 メモリモジュール DDR2 533 / 667 / 800をサポート 登録済みDIMMとECC DIMMはサポートされません	DDR2 DIMMスロット x 2 最大メモリ容量 4GB 各DIMMは512MB/1GB/2GB DDR2をサポート シングル チャンネルモードDDR2 メモリモジュール DDR2 533 / 667 / 800をサポート 登録済みDIMMとECC DIMMはサポートされません
Super I/O	ITE 8718F もつとも一般に使用されるレガシーSuper I/O機能を 採用しています。 低ピンカウントインターフェイス 環境コントロールインシニアチブ、 H/Wモニター ファン速度コントローラ/ モニター ITEの「スマートガーディアン」機能	ITE 8718F もつとも一般に使用されるレガシーSuper I/O機能を 採用しています。 低ピンカウントインターフェイス 環境コントロールインシニアチブ、 H/Wモニター ファン速度コントローラ/ モニター ITEの「スマートガーディアン」機能
グラフィック ス	GeForce 7150/nForce 630i 最大の共有ビデオメモリは512MBです(under OS)	GeForce 7100/nForce 630i 最大の共有ビデオメモリは512MBです(under OS)
IDE	統合IDEコントローラ Ultra DMA 33 / 66 / 100 / 133バスマスタモード PIO Mode 0~4のサポート、	統合IDEコントローラ Ultra DMA 33 / 66 / 100 / 133バスマスタモード PIO Mode 0~4のサポート、
SATA II	統合シリアルATAコントローラ 最高3 Gb/秒のデータ転送速度 SATAバージョン2.0仕様に準拠。	統合シリアルATAコントローラ 最高3 Gb/秒のデータ転送速度 SATAバージョン2.0仕様に準拠。
LAN	Realtek 8111B / 8111C(オプション) 10 / 100 Mb/秒および1Gb/秒のオートネゴシエーシ ョン 半/全二重機能	Realtek 8111B / 8111C(オプション) 10 / 100 Mb/秒および1Gb/秒のオートネゴシエーシ ョン 半/全二重機能

TF7150U-M7/TF7100P-M7

	TF7150U-M7	TF7100P-M7
サウンド Codec	ALC 888 / GeForce 7150 nForce 630iチップセットに統合 (HDMI audio) 7.1チャンネルオーディオアウト (ALC888) 2チャンネルオーディオアウト (HDMI audio) ハイデフィニションオーディオのサポート	ALC 888 / GeForce 7100 nForce 630iチップセットに統合 (HDMI audio) 7.1チャンネルオーディオアウト (ALC888) 2チャンネルオーディオアウト (HDMI audio) ハイデフィニションオーディオのサポート
スロット	PCIスロット x2 PCI Express x16スロット x1 PCI Express x 1スロット x1	PCIスロット x2 PCI Express x16スロット x1 PCI Express x 1スロット x1
オンボードコ ネクタ	フロッピーコネクタ x1 プリンタポートコネクタ x1 IDEコネクタ x1 SATAコネクタ x4 フロントパネルコネクタ x1 フロントオーディオコネクタ x1 CDインコネクタ x1 S/PDIFアウトコネクタ x1 CPUファンヘッダ x1 システムファンヘッダ x2 CMOSクリアヘッダ x1 USBコネクタ x3 シリアルポートコネクタ x1 電源コネクタ(24ピン) x1 電源コネクタ(4ピン) x1	フロッピーコネクタ x1 プリンタポートコネクタ x1 IDEコネクタ x1 SATAコネクタ x4 フロントパネルコネクタ x1 フロントオーディオコネクタ x1 CDインコネクタ x1 S/PDIFアウトコネクタ x1 CPUファンヘッダ x1 システムファンヘッダ x2 CMOSクリアヘッダ x1 USBコネクタ x3 シリアルポートコネクタ x1 電源コネクタ(24ピン) x1 電源コネクタ(4ピン) x1
背面パネル I/O	PS/2キーボード x1 HDMIポート x1 VGAポート x1 DVI-Dポート x1 LANポート x1 USBポート x4 オーディオジャック x6	PS/2キーボード x1 HDMIポート x1 VGAポート x1 DVI-Dポート x1 LANポート x1 USBポート x4 オーディオジャック x6
ボードサイズ	244 mm (幅) X 244 mm (高さ)	244 mm (幅) X 244 mm (高さ)
特殊機能	RAID 0 / 1 / 5 / 0+1 のサポート	RAID 0 / 1 / 5 / 0+1 のサポート
OSサポート	Windows XP / VISTA Biostarは事前のサポートなしにOSサポートを追加ま たは削除する権利を留保します。	Windows XP / VISTA Biostarは事前のサポートなしにOSサポートを追加ま たは削除する権利を留保します。

2008/01/04