

FCC Information and Copyright

This equipment has been tested and found to comply with the limits of a Class B digital device, pursuant to Part 15 of the FCC Rules. These limits are designed to provide reasonable protection against harmful interference in a residential installation. This equipment generates, uses, and can radiate radio frequency energy and, if not installed and used in accordance with the instructions, may cause harmful interference to radio communications. There is no guarantee that interference will not occur in a particular installation.

The vendor makes no representations or warranties with respect to the contents here and specially disclaims any implied warranties of merchantability or fitness for any purpose. Further the vendor reserves the right to revise this publication and to make changes to the contents here without obligation to notify any party beforehand.

Duplication of this publication, in part or in whole, is not allowed without first obtaining the vendor's approval in writing.

The content of this user's manual is subject to be changed without notice and we will not be responsible for any mistakes found in this user's manual. All the brand and product names are trademarks of their respective companies.



Dichiarazione di conformità sintetica

Ai sensi dell'art. 2 comma 3 del D.M. 275 del 30/10/2002

Si dichiara che questo prodotto è conforme alle normative vigenti e soddisfa i requisiti essenziali richiesti dalle direttive

2004/108/CE, 2006/95/CE e 1999/05/CE

quando ad esso applicabili

Short Declaration of conformity

We declare this product is complying with the laws in force and meeting all the essential requirements as specified by the directives

2004/108/CE, 2006/95/CE and 1999/05/CE

whenever these laws may be applied

Table of Contents

Chapter 1: Introduction	1
1.1 Before You Start	1
1.2 Package Checklist	1
1.3 Motherboard Features	2
1.4 Rear Panel Connectors	3
1.5 Motherboard Layout	4
Chapter 2: Hardware Installation	5
2.1 Installing Central Processing Unit (CPU)	5
2.2 FAN Headers	7
2.3 Installing System Memory	8
2.4 Connectors and Slots	10
Chapter 3: Headers & Jumpers Setup	13
3.1 How to Setup Jumpers	13
3.2 Detail Settings	13
Chapter 4: RAID Functions	19
4.1 Operating System	19
4.2 Raid Arrays	19
4.3 How RAID Works	19
Chapter 5: T-Series BIOS & Software	23
5.1 T-Series BIOS	23
5.2 T-Series Software	23
Chapter 6: Useful Help	36
6.1 Driver Installation Note	36
6.2 Extra Information	37
6.3 AMI BIOS Beep Code	38
6.4 AMI BIOS Post Code	39
6.5 Troubleshooting	41
Appendix: SPEC In Other Languages	42
German	42
French	44
Italian	46
Spanish	48
Portuguese	50
Polish	52
Russian	54
Arabic	56
Japanese	58

CHAPTER 1: INTRODUCTION

1.1 BEFORE YOU START

Thank you for choosing our product. Before you start installing the motherboard, please make sure you follow the instructions below:

- Prepare a dry and stable working environment with sufficient lighting.
- Always disconnect the computer from power outlet before operation.
- Before you take the motherboard out from anti-static bag, ground yourself properly by touching any safely grounded appliance, or use grounded wrist strap to remove the static charge.
- Avoid touching the components on motherboard or the rear side of the board unless necessary. Hold the board on the edge, do not try to bend or flex the board.
- Do not leave any unfastened small parts inside the case after installation. Loose parts will cause short circuits which may damage the equipment.
- Keep the computer from dangerous area, such as heat source, humid air and water.
- The operating temperatures of the computer should be 0 to 45 degrees Celsius.

1.2 PACKAGE CHECKLIST

- ✚ Serial ATA Cable X 4
- ✚ Rear I/O Panel for ATX Case X 1
- ✚ User's Manual X 1
- ✚ Fully Setup Driver CD X 1

Note: The package contents may be different due to area or your motherboard version.

1.3 MOTHERBOARD FEATURES

SPEC			
CPU	Socket AM3+ AMD Sempron / Phenom II / Athlon II / FX processors		AMD 64 Architecture enables 32 and 64 bit computing Supports Hyper Transport 3.0
FSB	Support HyperTransport 3.0 Supports up to 4.8 GT/s Bandwidth		
Chipset	AMD 970 AMD SB950		
Super I/O	ITE 8728 Provides the most commonly used legacy Super I/O functionality Low Pin Count Interface		Environment Control initiatives H/W Monitor Fan Speed Controller ITE's "Smart Guardian" function
Main Memory	DDR3 DIMM Slots x 4 Max Memory Capacity 32GB Each DIMM supports 512MB/ 1GB/2GB/4GB/8GB DDR3		Dual Channel Mode DDR3 memory module Supports DDR3 800/1066/1333/1600/1866 Supports DDR3 2000 (OC)
SATA III	Integrated Serial ATA Controller		Data transfer rates up to 6 Gb/s. SATA Version 3.0 specification compliant. RAID 0,1,5,10 support
LAN	Realtek RTL 8111E		10 / 100 Mb/s / 1Gb/s auto negotiation Half / Full duplex capability
Sound	ALC892		7.1channels audio out Supports HD Audio
USB3.0	Asmedia ASM1042		Data transfer rates up to 600 MB/s
IEEE 1394	VIA VT6315N		1394a
Slots	PCI Slot	x2	Supports PCI expansion cards
	PCI Express Gen2 x1 Slot	x2	Supports PCI-E Gen2 x1 expansion card
	PCI Express Gen2 x16 Slot	x2	Supports PCI-E Gen2 x16, x4 expansion cards
On Board Connectors	SATA Connector	x5	Each connector supports 1 SATA device
	Front Panel Connector	x1	Supports front panel facilities
	Front Audio Connector	x1	Supports front panel audio function
	S/PDIF out Connector	x1	Supports digital audio out function
	Consumer IR Connector	x1	Supports infrared function
	CPU Fan Header	x1	CPU Fan power supply (with Smart Fan function)
	System Fan Header	x2	System Fan Power supply
	CMOS clear Header	x1	Restore CMOS data to factory default
	USB2.0 Connector	x2	Each connector supports 2 front panel USB2.0 ports

SPEC			
	IEEE 1394 Connector	x1	Connects to IEEE 1394 device
	Printer Port Connector	x1	Each connector supports 1 Printer port
	Serial Port Connector	x1	Connects to RS-232 Port
	Power Connector (24-Pin)	x1	Connects to Power supply
	Power Connector (4-Pin)	x1	Connects to Power supply
Back Panel I/O	PS/2 Keyboard / Mouse	x1	Connects to PS/2 Keyboard/Mouse
	Optical +coaxial S/PDIF Out	x1	Provides digital audio out function
	1394 Port	x1	Connects to IEEE 1394 device
	eSATA Port	x1	Connect to SATA devices
	LAN port	x1	Connect to RJ-45 ethernet cable
	USB2.0 Port	x6	Connect to USB2.0 devices
	USB3.0 Port	x2	Connect to USB3.0 devices (by Asmedia ASM1042) and USB2.0/USB1.X devices (by SB950)
	Audio Jack	x6	Provide Audio-In/Out and Mic. connection
Board Size	305 mm (W) x 225 mm (L)		ATX
OS Support	Windows XP / Vista / 7		Biostar reserves the right to add or remove support for any OS With or without notice.

1.4 REAR PANEL CONNECTORS

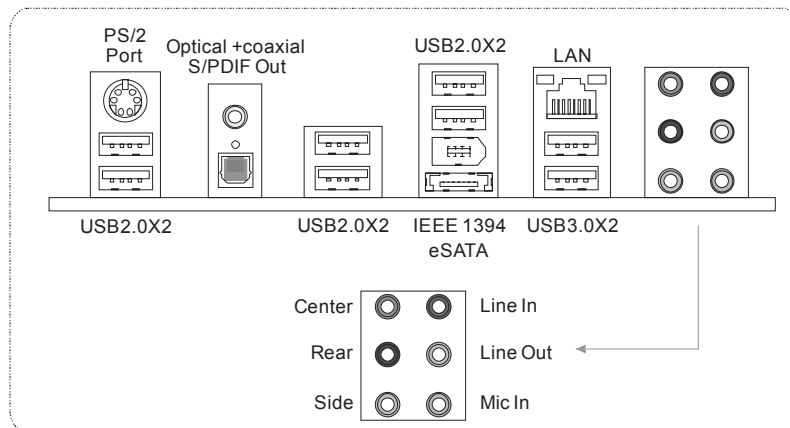

1.5 MOTHERBOARD LAYOUT

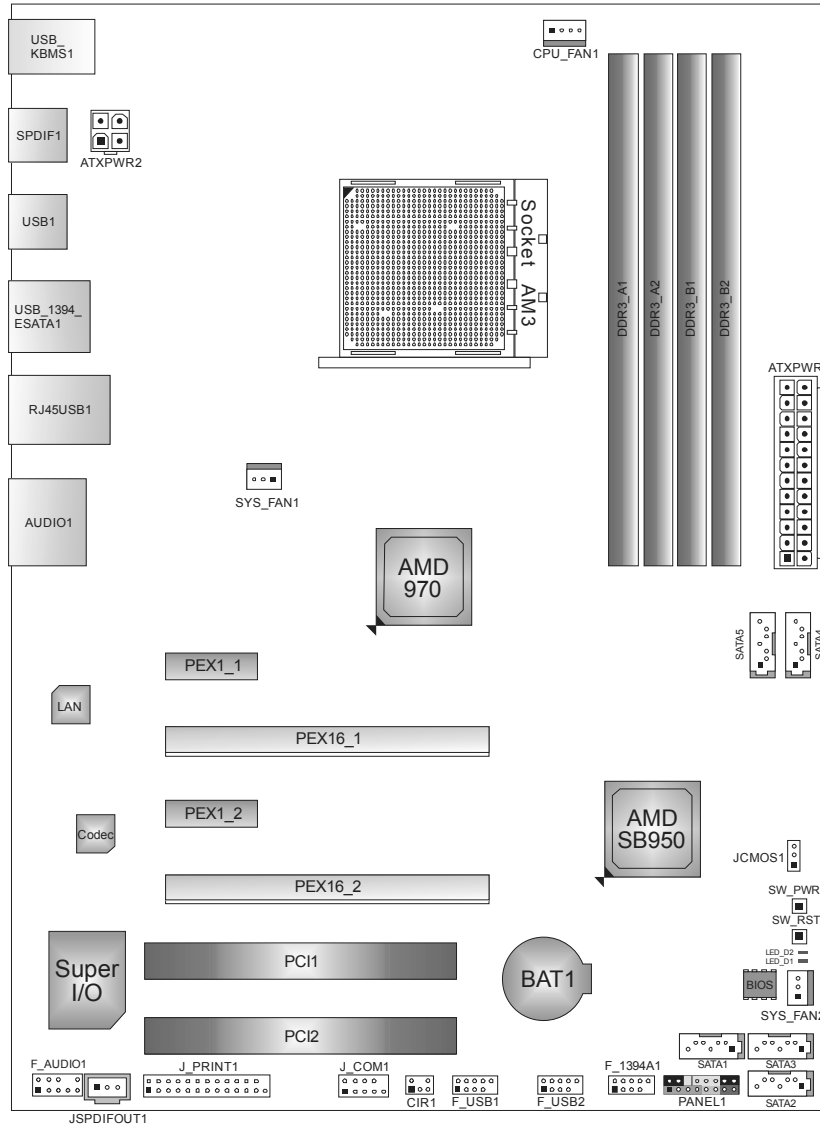

Note: ■ represents the 1st pin.

CHAPTER 2: HARDWARE INSTALLATION

2.1 INSTALLING CENTRAL PROCESSING UNIT (CPU)

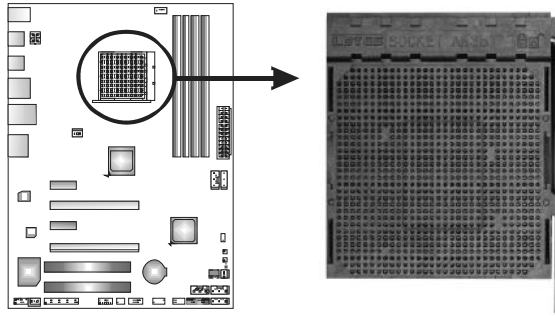

Step 1: Pull the lever toward direction A from the socket and then raise the lever up to a 90-degree angle.

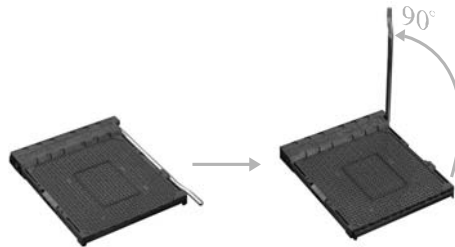

Step 2: Look for the white triangle on socket, and the gold triangle on CPU should point towards this white triangle. The CPU will fit only in the correct orientation.

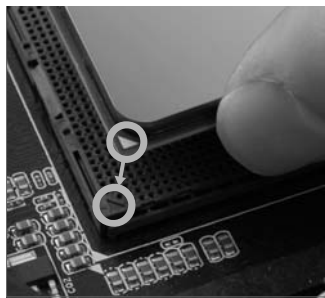

Step 3: Hold the CPU down firmly, and then close the lever toward direct B to complete the installation.

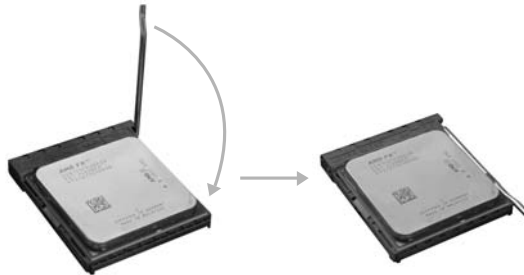

Step 4: Put the CPU Fan on the CPU and buckle it. Connect the CPU FAN power cable to the CPU_FAN1. This completes the installation.

2.2 FAN HEADERS

These fan headers support cooling-fans built in the computer. The fan cable and connector may be different according to the fan manufacturer. Connect the fan cable to the connector while matching the black wire to pin#1.

CPU_FAN1: CPU Fan Header

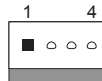
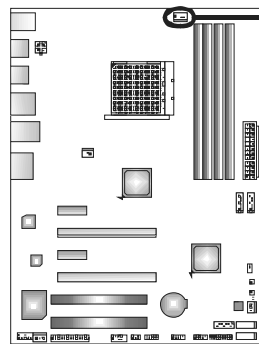

Pin	Assignment
1	Ground
2	+12V
3	FAN RPM rate sense
4	Smart Fan Control (By Fan)

SYS_FAN1: NorthBridge Fan Header

SYS_FAN2: System Fan Header

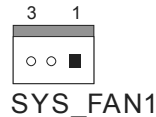
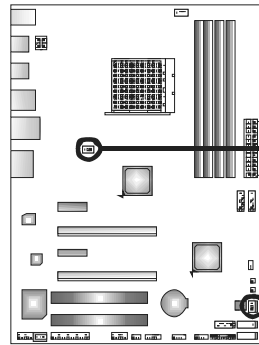

SYS_FAN1

Pin	Assignment
1	Ground
2	+12V
3	FAN RPM rate sense

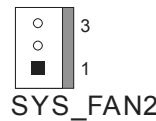

SYS_FAN2

Note:

CPU_FAN1, SYS_FAN1/2 support 4-pin and 3-pin head connectors. When connecting with wires onto connectors, please note that the red wire is the positive and should be connected to pin#2, and the black wire is Ground and should be connected to GND.

2.3 INSTALLING SYSTEM MEMORY

A. DDR3 Modules

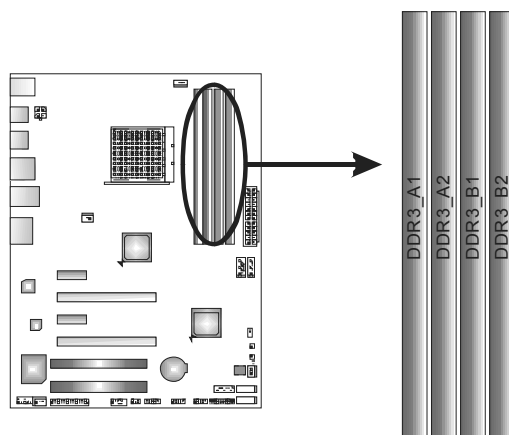

1. Unlock a DIMM slot by pressing the retaining clips outward. Align a DIMM on the slot such that the notch on the DIMM matches the break on the Slot.

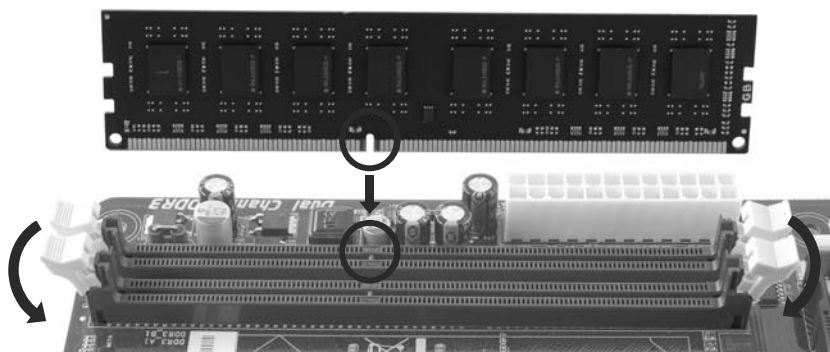

2. Insert the DIMM vertically and firmly into the slot until the retaining chip snap back in place and the DIMM is properly seated.

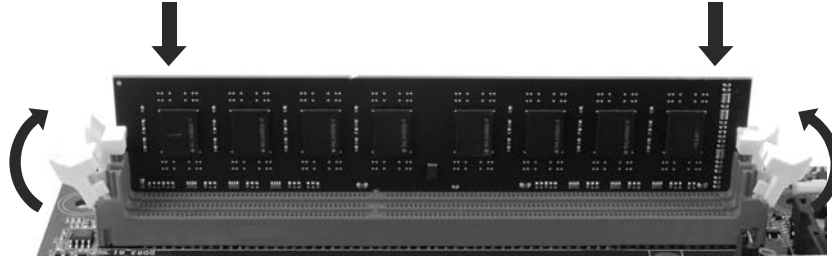

Note:

If the DIMM does not go in smoothly, do not force it. Pull it all the way out and try again.

B. Memory Capacity

DIMM Socket Location	DDR3 Module	Total Memory Size
DDR3_A1	512MB/1GB/2GB/4GB/8GB	Max is 32GB.
DDR3_A2	512MB/1GB/2GB/4GB/8GB	
DDR3_B1	512MB/1GB/2GB/4GB/8GB	
DDR3_B2	512MB/1GB/2GB/4GB/8GB	

C. Dual Channel Memory Installation

Please refer to the following requirements to activate Dual Channel function:

Install memory module of the same density in pairs, shown in the table.

Dual Channel Status	DDR3_A1	DDR3_A2	DDR3_B1	DDR3_B2
Enabled	X	O	X	O
Enabled	O	O	O	O

(O means memory installed, X means memory not installed.)

The DRAM bus width of the memory module must be the same (x8 or x16)

Note:

Memory module must be installed in DDR3-A2 or DDR3-B2 to boot the system.

2.4 CONNECTORS AND SLOTS

SATA1~SATA5: Serial ATA Connectors

The motherboard has a PCI to SATA Controller with 5 channels SATA interface, it satisfies the SATA 3.0 spec and with transfer rate of 6.0Gb/s.

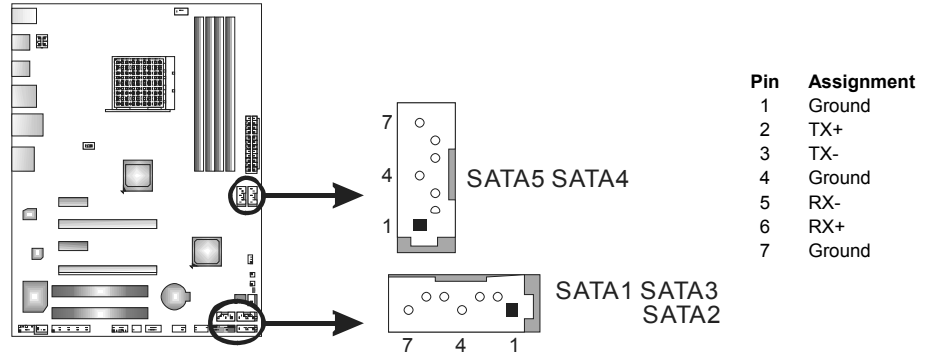

ATXPWR2: ATX Power Source Connector

This connector provides +12V to CPU power circuit.

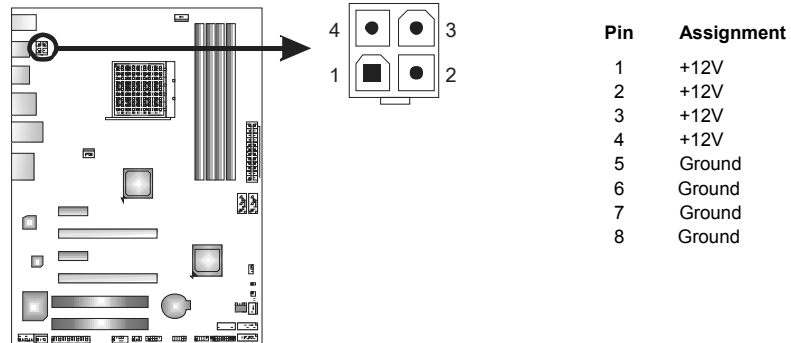

ATXPWR1: ATX Power Source Connector

This connector allows user to connect 24-pin power connector on the ATX power supply.

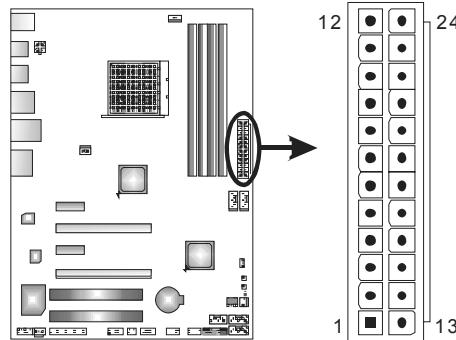

Pin	Assignment	Pin	Assignment
13	+3.3V	1	+3.3V
14	-12V	2	+3.3V
15	Ground	3	Ground
16	PS_ON	4	+5V
17	Ground	5	Ground
18	Ground	6	+5V
19	Ground	7	Ground
20	NC	8	PW_OK
21	+5V	9	Standby Voltage+5V
22	+5V	10	+12V
23	+5V	11	+12V
24	Ground	12	+3.3V

Note:

Before you power on the system, please make sure that both ATXPWR1 and ATXPWR2 connectors have been plugged-in.

PCI1/PCI2: Peripheral Component Interconnect Slots

PCI stands for Peripheral Component Interconnect, and it is a bus standard for expansion cards. This PCI slot is designated as 32 bits.

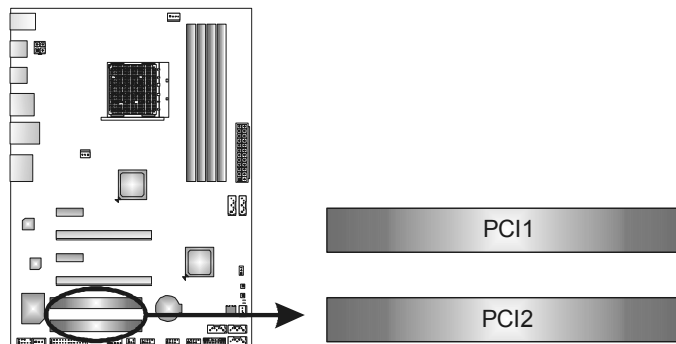

PEX16_1: PCI-Express Gen2 x16 Slot

- PCI-Express 2.0 compliant.
- Maximum theoretical realized bandwidth of 8GB/s simultaneously per direction, for an aggregate of 16GB/s totally.
- PCI-Express Gen2 supports a raw bit-rate of 5.0Gb/s on the data pins.

PEX16_2: PCI-Express Gen2 x4 Slot

- PCI-Express 2.0 compliant.
- Data transfer bandwidth up to 2GB/s per direction;4GB/s in total.
- PCI-Express Gen2 supports a raw bit-rate of 2.5Gb/s on the data pins.

PEX1_1/PEX1_2: PCI-Express Gen2 x1 Slot

- PCI-Express 2.0 compliant.
- Data transfer bandwidth up to 500MB/s per direction; 1GB/s in total.

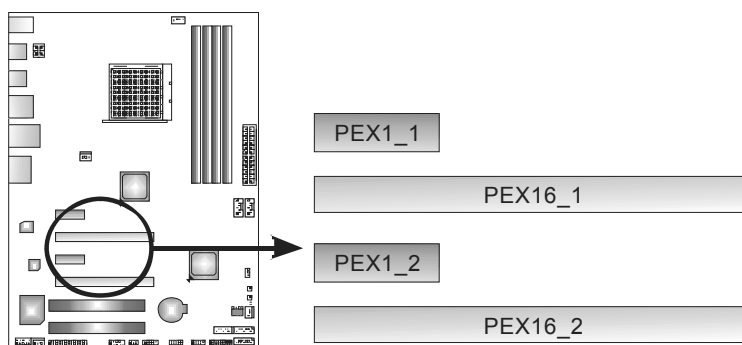

CHAPTER 3: HEADERS & JUMPERS SETUP

3.1 HOW TO SETUP JUMPERS

The illustration shows how to set up jumpers. When the jumper cap is placed on pins, the jumper is “close”, if not, that means the jumper is “open”.



3.2 DETAIL SETTINGS

PANEL1: Front Panel Header

This 16-pin connector includes Power-on, Reset, HDD LED, Power LED, and speaker connection. It allows user to connect the PC case's front panel switch functions.

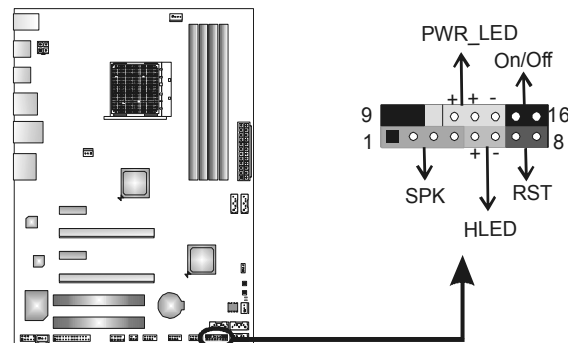

Pin	Assignment	Function	Pin	Assignment	Function
1	+5V		9	N/A	N/A
2	N/A	Speaker Connector	10	N/A	N/A
3	N/A		11	N/A	N/A
4	Speaker		12	Power LED (+)	Power LED
5	HDD LED (+)	13	Power LED (+)		
6	HDD LED (-)	14	Power LED (-)		
7	Ground	Reset button	15	Power button	Power-on button
8	Reset control		16	Ground	

JCMOS1: Clear CMOS Header

Placing the jumper on pin2-3 allows user to restore the BIOS safe setting and the CMOS data. Please carefully follow the procedures to avoid damaging the motherboard.

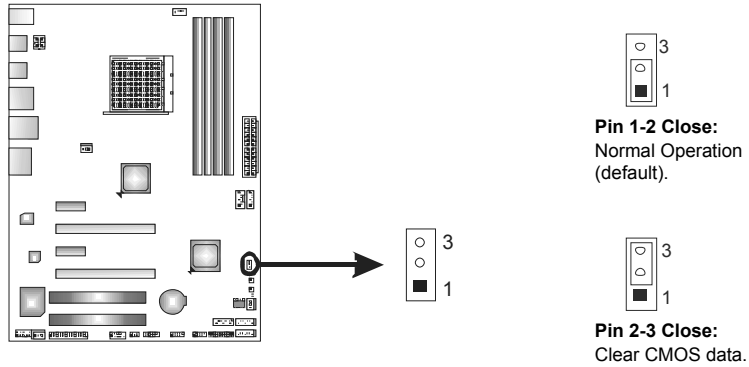

※ Clear CMOS Procedures:

1. Remove AC power line.
2. Set the jumper to "Pin 2-3 close".
3. Wait for five seconds.
4. Set the jumper to "Pin 1-2 close".
5. Power on the AC.
6. Load Optimal Defaults and save settings in CMOS.

J_COM1: Serial port Connector

The motherboard has a Serial Port Connector for connecting RS-232 Port.

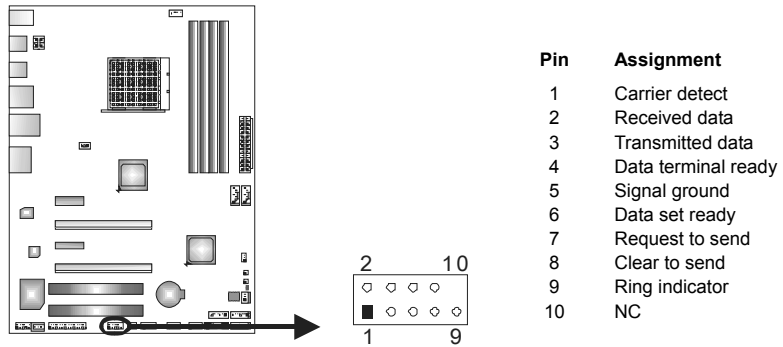

F_AUDIO1: Front Panel Audio Header

This header allows user to connect the front audio output cable with the PC front panel. This header allows only HD audio front panel connector; AC'97 connector is not acceptable.

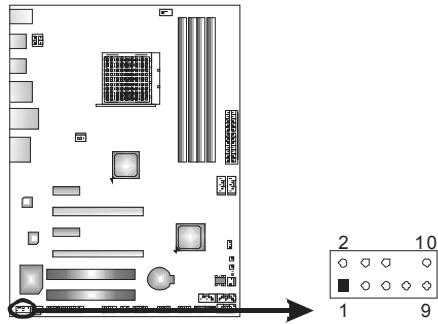

Pin	Assignment
1	Mic Left in
2	Ground
3	Mic Right in
4	GPIO
5	Right line in
6	Jack Sense
7	Front Sense
8	Key
9	Left line in
10	Jack Sense

JSPDIFOUT1: Digital Audio-out Connector

This connector allows user to connect the PCI bracket SPDIF output header.

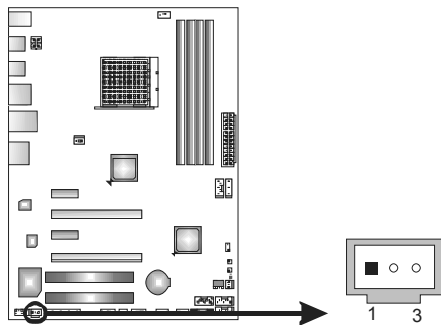

Pin	Assignment
1	+5V
2	SPDIF_OUT
3	Ground

CIR1: Consumer IR Connector

This header is for infrared remote control and communication.

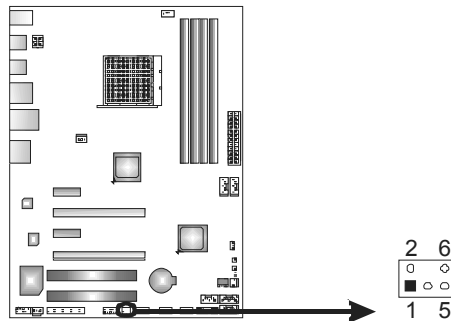

Pin	Assignment
1	IrDA serial input
2	Ground
3	Ground
4	Key
5	IrDA serial output
6	IR Power

F_1394A1: IEEE 1394 Header

This header allows user to connect IEEE 1394 device.

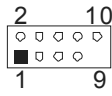
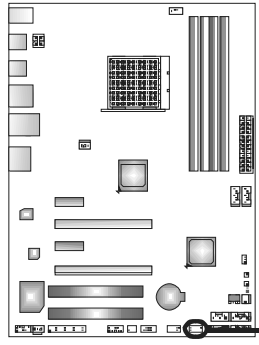

Pin	Assignment
1	TPA1+
2	TPA1-
3	GND
4	GND
5	TPB1+
6	TPB1-
7	VCC
8	VCC
9	N/A
10	KEY

J_PRINT1: Printer Port Connector

This header allows you to connector printer on the PC.

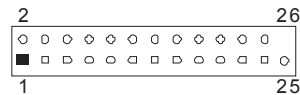
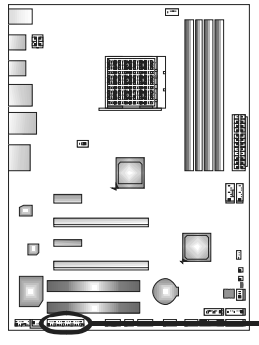

Pin	Assignment	Pin	Assignment
1	-Strobe	14	Ground
2	-ALF	15	Data 6
3	Data 0	16	Ground
4	-Error	17	Data 7
5	Data 1	18	Ground
6	-Init	19	-ACK
7	Data 2	20	Ground
8	-Scltin	21	Busy
9	Data 3	22	Ground
10	Ground	23	PE
11	Data 4	24	Ground
12	Ground	25	SCLT
13	Data 5	26	Key

F_USB1/F_USB2: Headers for USB 2.0 Ports at Front Panel

These headers allow user to connect additional USB cable on the PC front panel, and also can be connected with internal USB devices, like USB card reader.

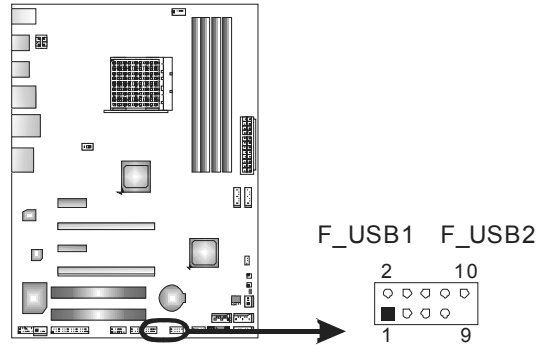

Pin	Assignment
1	+5V (fused)
2	+5V (fused)
3	USB-
4	USB-
5	USB+
6	USB+
7	Ground
8	Ground
9	Key
10	NC

On-Board Buttons

There are 2 on-board buttons.

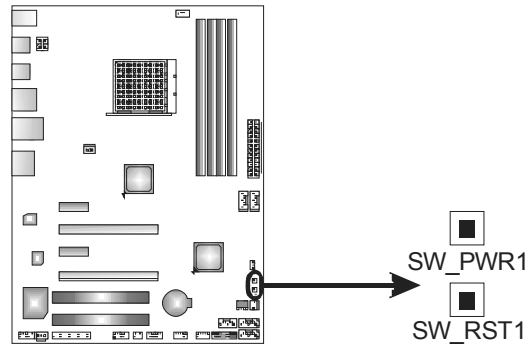

SW_RST1: Reset button.
SW_PWR1: Power Switch button.

On-Board LED Indicators

There are 2 LED indicators showing system status.

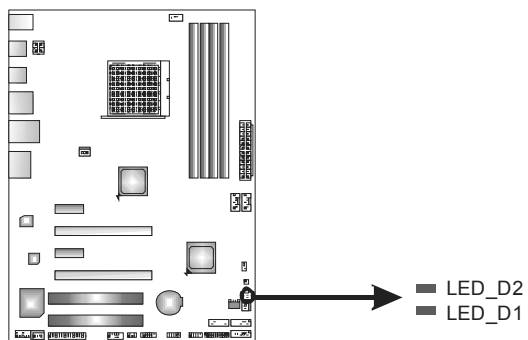

LED_D1 & LED_D2: Debug Indicators

CHAPTER 4: RAID FUNCTIONS

4.1 OPERATING SYSTEM

Supports Windows Vista and Windows 7.

4.2 RAID ARRAYS

RAID supports the following types of RAID arrays:

RAID 0: RAID 0 defines a disk striping scheme that improves disk read and write times for many applications.

RAID 1: RAID 1 defines techniques for mirroring data.

RAID 10: RAID 10 combines the techniques used in RAID 0 and RAID 1.

RAID 5: RAID 5 provides fault tolerance and better utilization of disk capacity.

4.3 How RAID WORKS

RAID 0:

The controller “stripes” data across multiple drives in a RAID 0 array system. It breaks up a large file into smaller blocks and performs disk reads and writes across multiple drives in parallel. The size of each block is determined by the stripe size parameter, which you set during the creation of the RAID set based on the system environment. This technique reduces overall disk access time and offers high bandwidth.

Features and Benefits

- **Drives:** Minimum 2, and maximum is up to 6 or 8. Depending on the platform.
- **Uses:** Intended for non-critical data requiring high data throughput, or any environment that does not require fault tolerance.
- **Benefits:** provides increased data throughput, especially for large files. No capacity loss penalty for parity.
- **Drawbacks:** Does not deliver any fault tolerance. If any drive in the array fails, all data is lost.
- **Fault Tolerance:** No.

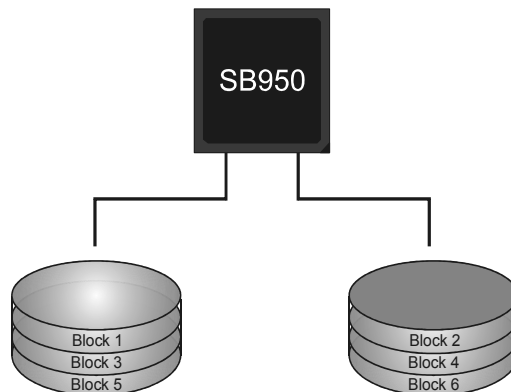

RAID 1:

Every read and write is actually carried out in parallel across 2 disk drives in a RAID 1 array system. The mirrored (backup) copy of the data can reside on the same disk or on a second redundant drive in the array. RAID 1 provides a hot-standby copy of data if the active volume or drive is corrupted or becomes unavailable because of a hardware failure. RAID techniques can be applied for high-availability solutions, or as a form of automatic backup that eliminates tedious manual backups to more expensive and less reliable media.

Features and Benefits

- **Drives:** Minimum 2, and maximum is 2.
- **Uses:** RAID 1 is ideal for small databases or any other application that requires fault tolerance and minimal capacity.
- **Benefits:** Provides 100% data redundancy. Should one drive fail, the controller switches to the other drive.
- **Drawbacks:** Requires 2 drives for the storage space of one drive. Performance is impaired during drive rebuilds.
- **Fault Tolerance:** Yes.

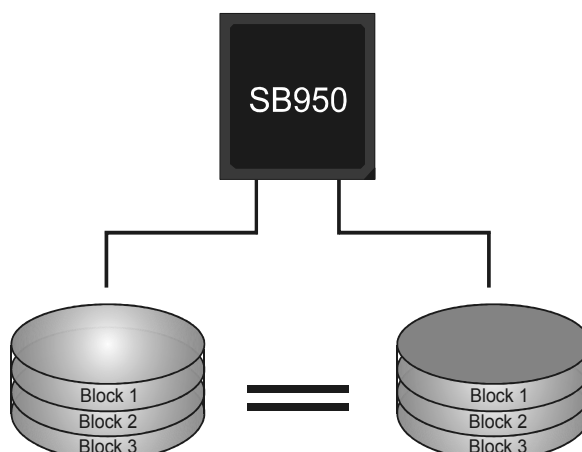

RAID 10:

RAID 1 drives can be striped using RAID 0 techniques. Resulting in a RAID 10 solution for improved resiliency, performance and rebuild performance.

Features and Benefits

- **Drives:** Minimum 4, and maximum is 6 or 8, depending on the platform.
- **Benefits:** Optimizes for both fault tolerance and performance, allowing for automatic redundancy. May be simultaneously used with other RAID levels in an array, and allows for spare disks.
- **Drawbacks:** Requires twice the available disk space for data redundancy, the same as RAID level 1.
- **Fault Tolerance:** Yes.

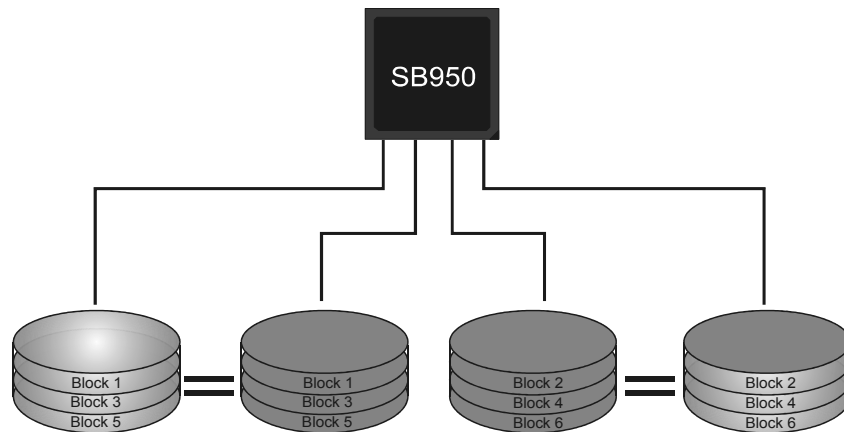

RAID 5:

RAID 5 stripes both data and parity information across three or more drives. It writes data and parity blocks across all the drives in the array. Fault tolerance is maintained by ensuring that the parity information for any given block of data is placed on a different drive from those used to store the data itself.

Features and Benefits

- **Drives:** Minimum 3.
- **Uses:** RAID 5 is recommended for transaction processing and general purpose service.
- **Benefits:** An ideal combination of good performance, good fault tolerance, and high capacity and storage efficiency.
- **Drawbacks:** Individual block data transfer rate same as a single disk. Write performance can be CPU intensive.
- **Fault Tolerance:** Yes.

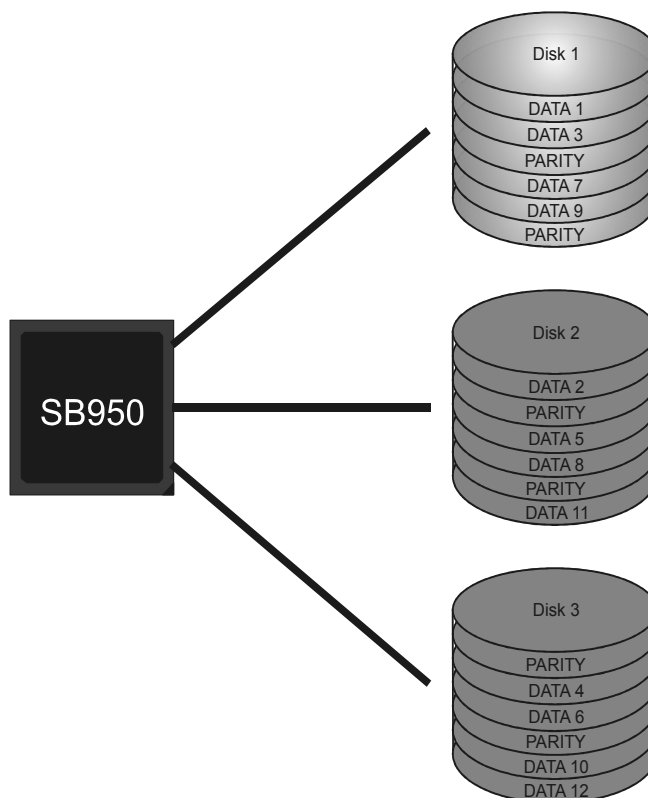

CHAPTER 5: T-SERIES BIOS & SOFTWARE

5.1 T-SERIES BIOS

T-Series UEFI BIOS Features

- Overclocking Navigator Engine (O.N.E.)
- Self Recovery System (S.R.S)
- Smart Fan Function
- BIO-Flasher: Update UEFI BIOS file from USB Flash Drive

!! WARNING !!

For better system performance, the UEFI BIOS firmware is being continuously updated. The UEFI BIOS information described below in this manual is for your reference only and the actual UEFI BIOS information and settings on board may be different from this manual. For further information of setting up the UEFI BIOS, please refer to the UEFI BIOS Manual in the Setup CD.

A. Overclocking Navigator Engine (O.N.E.)

O.N.E provides several systems allowing users to customize personal overclock settings, such as Manual Voltage System, Manual Memory System, Manual MCT System, and Manual G.P.U System, etc.



Notice:

Not all types of Intel CPU perform above overclock setting ideally; the difference will be based on the selected CPU model.

NOTE

Overclock is an optional process, but not a “must-do” process; it is not recommended for inexperienced users. Therefore, we will not be responsible for any hardware damage which may be caused by overclocking. We also would not guarantee any overclocking performance.

B. Self Recovery System (S.R.S.)

This function can't be seen under UEFI BIOS setup, and is always on whenever the system starts up.

However, it can prevent system hang-up due to inappropriate overclock actions.

When the system hangs up, S.R.S. will automatically log in the default UEFI BIOS setting, and all overclock settings will be re-configured.

C. Smart Fan Function

Smart Fan Function is under “Smart Fan Control” in “Advanced Menu”.

This is a brilliant feature to control CPU/System Temperature vs. Fan speed. When enabling Smart Fan function, Fan speed is controlled automatically by CPU/System temperature.

This function will protect CPU/System from overheat problem and maintain the system temperature at a safe level.





CPU Smart FAN

This item allows you to control the CPU Smart Fan function.

CPU FAN Calibrate

Press [ENTER] to calibrate CPU FAN.

Control Mode

This item provides several operation modes of the fan.

Fan Ctrl OFF(°C)

When CPU temperature is lower than this value, the CPU fan will keep lowest RPM. The range is from 0~127, with an interval of 1.

Fan Ctrl On(°C)

When CPU temperature is higher than this value, the CPU fan controller will turn on. The range is from 0~127, with an interval of 1.

Fan Ctrl Start Value

This item sets CPU FAN Start Speed Value. The range is from 0~127, with an interval of 1.

Fan Ctrl Sensitive

The bigger the numeral is, the higher the FAN speed is. The range is from 0~127, with an interval of 1.

5.2 T-SERIES SOFTWARE

Installing T-Series Software

1. Insert the Setup CD to the optical drive. The drivers installation program would appear if the Auto-run function has been enabled.
2. Select **Software Installation**, and then click on the respective software title.
3. Follow the on-screen instructions to complete the installation.

Launching T-Series Software

After the installation process is completed, you will see the software icon showing on the desktop. Double-click the icon to launch it.

TOverclocker

TOverclocker presents a simple Windows-based system performance enhancement and manageability utility. It features several powerful and easy to use tools such as Overclocking for enhancing system performance, also for special enhancement on CPU and Memory. Smart-Fan management and PC health are for monitoring system status. This utility also allows you to make overclocking profiles saving unlimitedly, and pre-set OC modes are for easy OC. (The illustration below is for reference only)

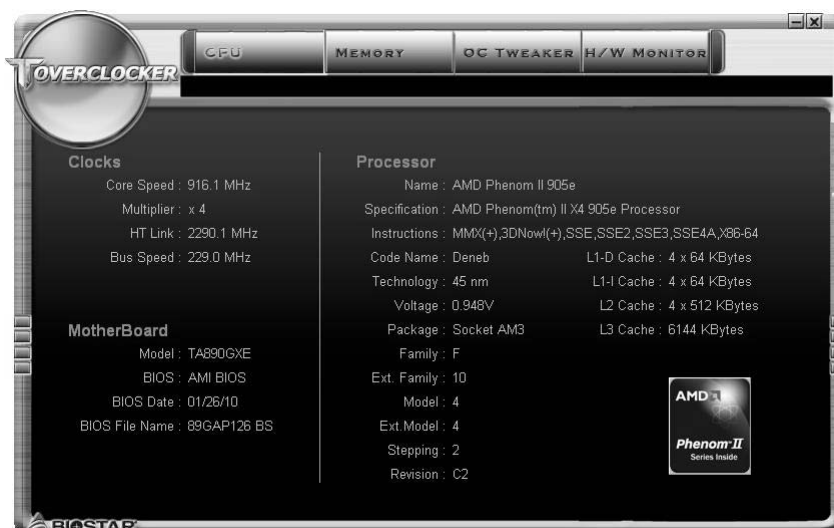



The **CPU** tab provides information on the CPU and motherboard.



The **Memory** tab provides information on the memory module(s).

You can select memory module on a specific slot to see its information.



The **OC Tweaker** tab allows you to change system clock settings and voltages settings. It also provides six pre-set modes for you:



Six Pre-set Modes: V3, V6, V9, V12, V15, AUTO for different overclocking experience.

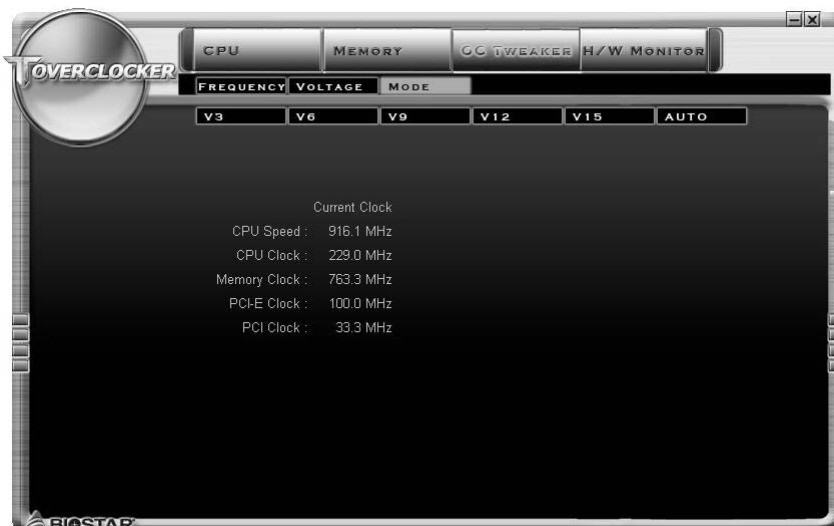

The **HW Monitor** tab allows you to monitor hardware voltage, fan speed, and temperature. Besides, you also can set related values for CPU Smart Fan.





Pressing **TOVERCLOCKER** logo will display information about manufacturer and software version. You can update current version by clicking the button "Live Update."



Green Power II Utility

BIOSTAR G.P.U II (Green Power Utility) is a new function. The utility enhances energy efficiency by disabling extra phases while CPU is on light loading; it features 4+1 power phases, current power saving, and total power saving. This tool integrates a friendly GUI to monitor your CPU Usage, CPU Watt, and CPU Temperature. Moreover, it optimizes power saving and best power efficiency on your system. (The illustration below is for reference only)

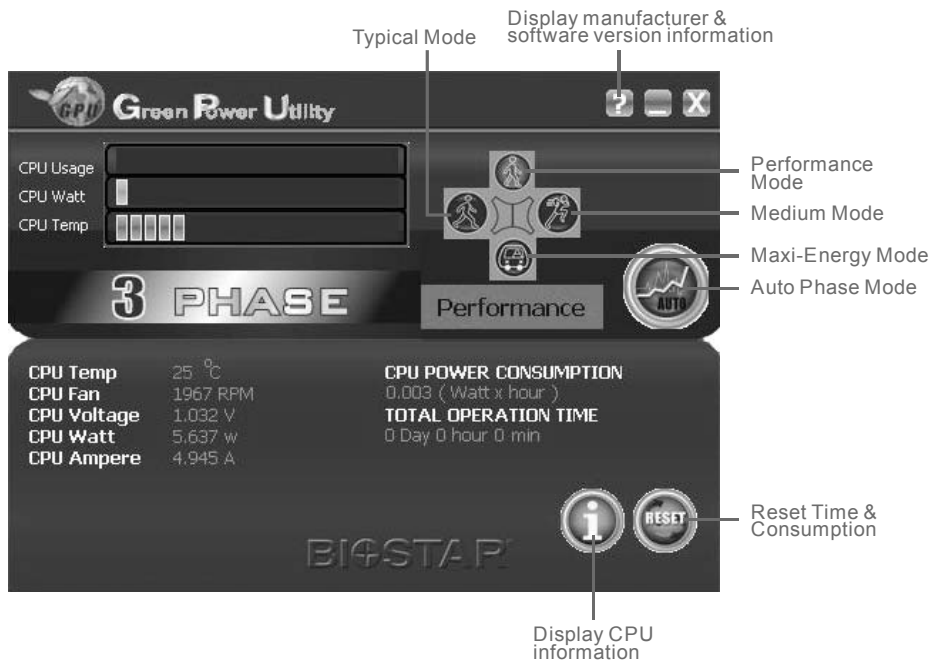

G.P.U Mode Setting

This utility provides five modes, upon your requirements, to improve system performance or to save power consumption.

Note: Even if the modes saving more power consumption are chosen, the system still can keep excellent performance.

- **Auto Phase Mode**
System switches the mode automatically according to current system loading condition.

- **Performance Mode**
This is the mode saving power consumption most. Least energy will be used in the system.

- **Typical Mode**
Compared with that in Performance Mode, energy consumption in this mode is a little bit more.

- **Medium Mode**
This is the standard system power saving mode.

- **Maxi-Energy Mode**
This is the best system performance mode.

eHot-Line (Optional)

eHot-Line is a convenient utility that helps you to contact with our Tech-Support system. This utility will collect the system information which is useful for analyzing the problem you may have encountered, and then send these information to our tech-support department to help you fix the problem.

 Before you use this utility, please set Outlook Express as your default e-mail client application program.

*represents important information that you must provide. Without this information, you may not be able to send out the mail.

This block will show the information which would be collected in the mail.

*Describe condition of your system.

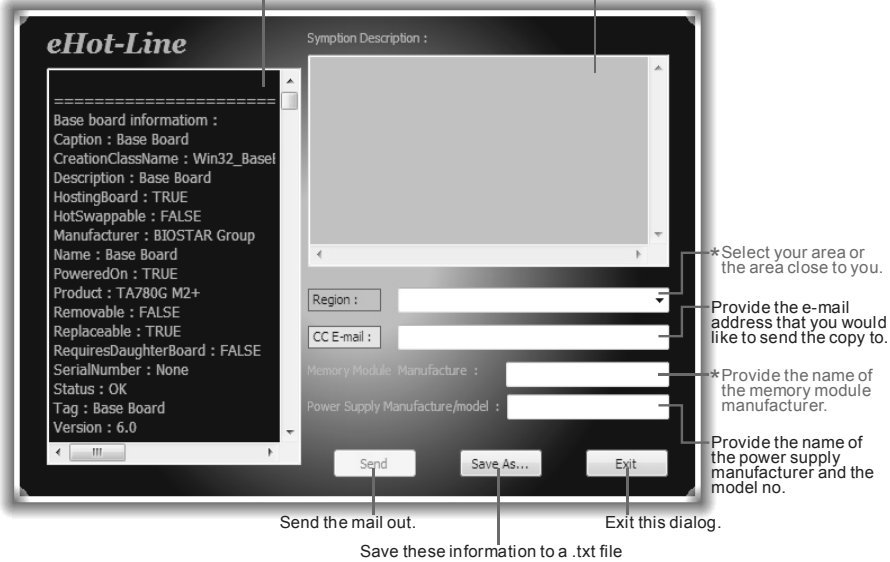

The screenshot shows the eHot-Line utility window. On the left, a text area displays system information: Base board information: Caption: Base Board, CreationClassName: Win32_Base, Description: Base Board, HostingBoard: TRUE, HotSwappable: FALSE, Manufacturer: BIOSTAR Group, Name: Base Board, PoweredOn: TRUE, Product: TA780G M2+, Removable: FALSE, Replaceable: TRUE, RequiresDaughterBoard: FALSE, SerialNumber: None, Status: OK, Tag: Base Board, Version: 6.0. On the right, there is a 'Symptom Description' text area, a 'Region' dropdown menu, a 'CC E-mail' text field, 'Memory Module Manufacture' and 'Power Supply Manufacture/model' text fields, and three buttons: 'Send', 'Save As...', and 'Exit'. Callouts provide instructions for each field and button.

After filling up this information, click **“Send”** to send the mail out. A warning dialog would appear asking for your confirmation; click **“Send”** to confirm or **“Do Not Send”** to cancel.



If you want to save this information to a .txt file, click **“Save As...”** and then you will see a saving dialog appears asking you to enter file name.

Enter the file name and then click “Save”. Your system information will be saved to a .txt file.

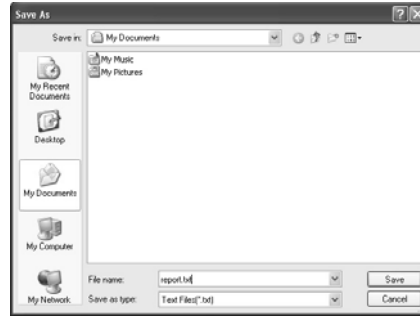

Open the saved .txt file, you will see your system information including motherboard/BIOS/CPU/video/device/OS information. This information is also included in the sent mail.



We will not share customer’s data with any other third parties, so please feel free to provide your system information while using eHot-Line service.



If you are not using Outlook Express as your default e-mail client application, you may need to save the system information to a .txt file and send the file to our tech support with other e-mail application. Go to the following web <http://www.biostar.com.tw/app/en-us/about/contact.php> for getting our contact information.

BIOS Update

BIOS Update is a convenient utility which allows you to update your motherboard BIOS under Windows system.

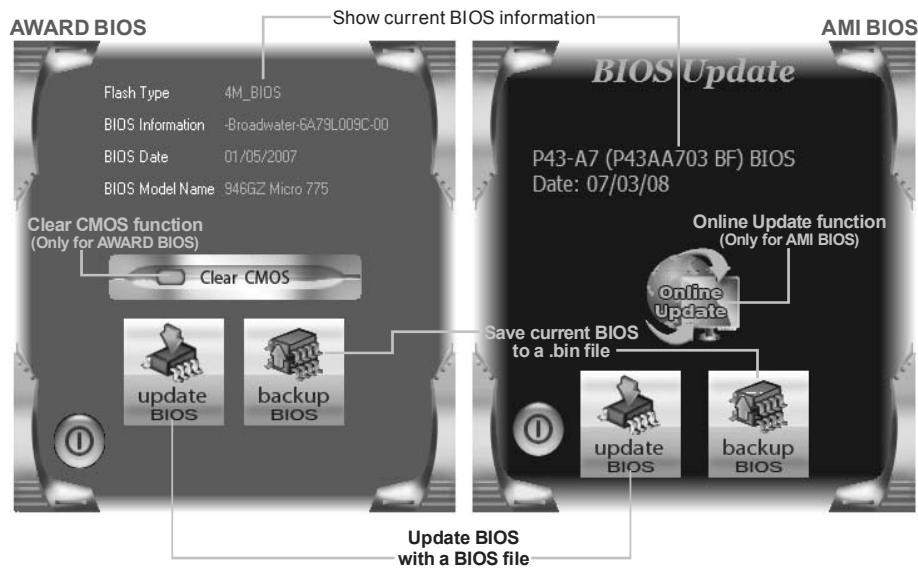

<Backup BIOS>

Once click on this button, the saving dialog will show. Choose the position to save file and enter file name. (We recommend that the file name should be English/number and no longer than 7 characters.) Then click **Save**.

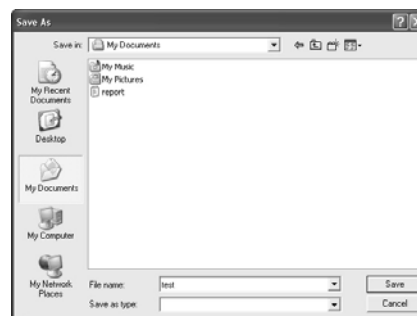

<Update BIOS>

Before doing this, please download the proper BIOS file from the website.

For AWARD BIOS, update BIOS procedure should be run with Clear CMOS function, so please check on Clear CMOS first.

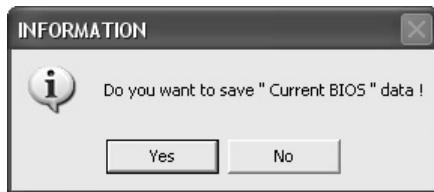
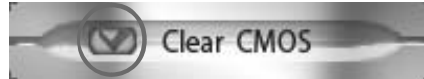

Then click Update BIOS button, a dialog will show for asking you backup current BIOS. Click **Yes** for BIOS backup and refer to the Backup BIOS procedure; or click **No** to skip this procedure.

After the BIOS Backup procedure, the open dialog will show for requesting the BIOS file which is going to be updated. Please choose the proper BIOS file for updating, then click on **Open**.

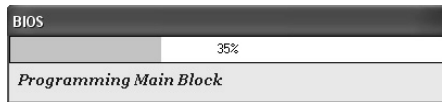
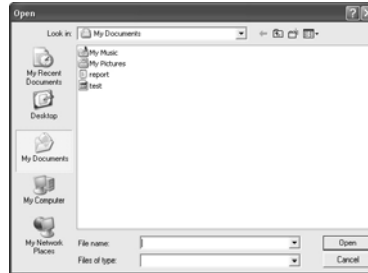

The utility will update BIOS with the proper BIOS file, and this process may take minutes. Please do not open any other applications during this process.

After the BIOS Update process, click on **OK** to restart the system.

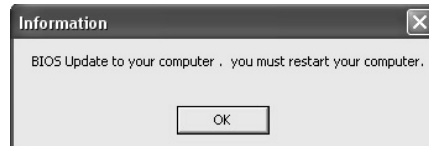

While the system boots up and the full screen logo shows, press  <Delete> key to enter BIOS setup.

In the BIOS setup, use the **Load Optimized Defaults** function and then **Save and Exit Setup** to exit BIOS setup. BIOS Update is completed.

<Online Update> (for AMI BIOS only)

Automatically download and update the latest BIOS via internet; **make sure that the computer is connected to the internet before using this function.**

After clicking on the **Online Update** button, the utility will search for the latest BIOS from internet. If there is a new BIOS version, the utility will ask you to download it. Click **Yes** to proceed.

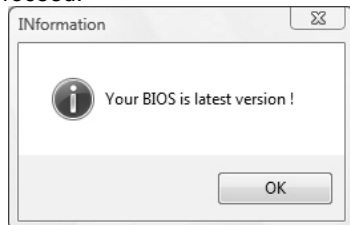
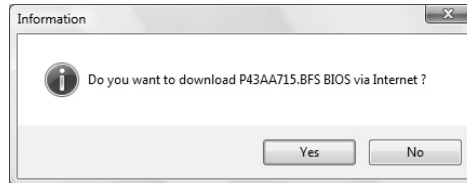

If there is no other newer BIOS version, the utility will also tell you that your BIOS has been the latest version.

Download completes; the utility will ask you to program (update) the BIOS. Click **Yes** to proceed.

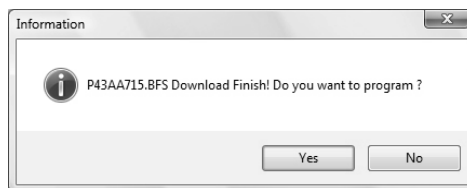

The programming procedure may take minutes, **please do not make any operation during the programming process.**

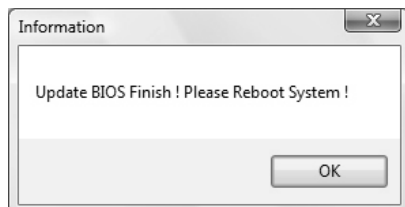

After the updating process, the utility will ask you to reboot the system. Click **OK** to reboot.

While the system boots up and the full screen logo shows, press  <Delete> key to enter BIOS setup.

In the BIOS setup, use the **Load Optimized Defaults** function and then **Save and Exit Setup** to exit BIOS setup. Online Update is completed.



All the information and content above about the T-Series software are subject to be changed without notice. For better performance, the software is being continuously updated. The information and pictures described above are for your reference only. The actual information and settings on board may be slightly different from this manual.

CHAPTER 6: USEFUL HELP

6.1 DRIVER INSTALLATION NOTE

After you installed your operating system, please insert the Fully Setup Driver CD into your optical drive and install the driver for better system performance.

You will see the following window after you insert the CD

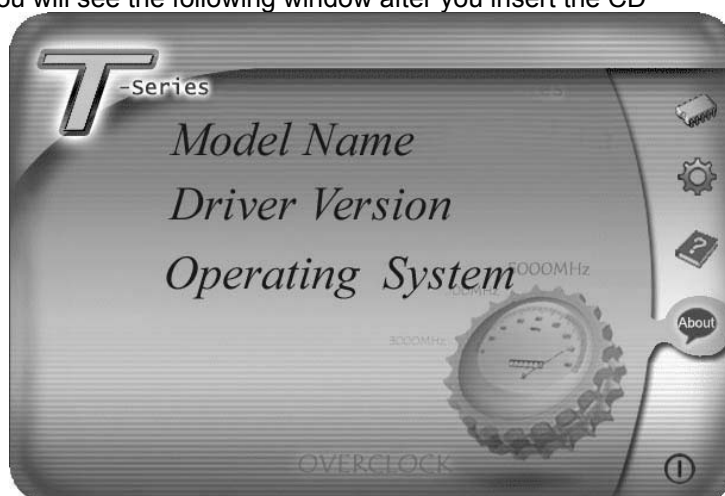

The setup guide will auto detect your motherboard and operating system.

Note:

If this window didn't show up after you insert the Driver CD, please use file browser to locate and execute the file **SETUP.EXE** under your optical drive.

A. Driver Installation

To install the driver, please click on the Driver icon. The setup guide will list the compatible driver for your motherboard and operating system. Click on each device driver to launch the installation program.

B. Software Installation

To install the software, please click on the Software icon. The setup guide will list the software available for your system, click on each software title to launch the installation program.

C. Manual

Aside from the paperback manual, we also provide manual in the Driver CD. Click on the Manual icon to browse for available manual.

Note:

You will need Acrobat Reader to open the manual file. Please download the latest version of Acrobat Reader software from <http://www.adobe.com/products/acrobat/readstep2.html>

6.2 EXTRA INFORMATION

CPU Overheated

If the system shutdown automatically after power on system for seconds, that means the CPU protection function has been activated.

When the CPU is over heated, the motherboard will shutdown automatically to avoid a damage of the CPU, and the system may not power on again.

In this case, please double check:

1. The CPU cooler surface is placed evenly with the CPU surface.
2. CPU fan is rotated normally.
3. CPU fan speed is fulfilling with the CPU speed.

After confirmed, please follow steps below to relief the CPU protection function.

1. Remove the power cord from power supply for seconds.
2. Wait for seconds.
3. Plug in the power cord and boot up the system.

Or you can:

1. Clear the CMOS data.
(See "Close CMOS Header: JCMOS1" section)
2. Wait for seconds.
3. Power on the system again.

6.3 AMI BIOS BEEP CODE

Boot Block Beep Codes

Number of Beeps	Description
1	No media present. (Insert diskette in floppy drive A:)
2	"AMIBOOT.ROM" file not found in root directory of diskette in A:
3	Insert next diskette if multiple diskettes are used for recovery
4	Flash Programming successful
5	File read error
7	No Flash EPROM detected
10	Flash Erase error
11	Flash Program error
12	"AMIBOOT.ROM" file size error
13	BIOS ROM image mismatch (file layout does not match image present in flash device)

POST BIOS Beep Codes

Number of Beeps	Description
1	Memory refresh timer error
3	Base memory read/write test error
6	Keyboard controller BAT command failed
7	General exception error (processor exception interrupt error)
8	Display memory error (system video adapter)

Troubleshooting POST BIOS Beep Codes

Number of Beeps	Troubleshooting Action
1, 3	Reseat the memory, or replace with known good modules.
6, 7	<p>Fatal error indicating a serious problem with the system. Consult your system manufacturer. Before declaring the motherboard beyond all hope, eliminate the possibility of interference by a malfunctioning add-in card. Remove all expansion cards except the video adapter.</p> <ul style="list-style-type: none"> ● If beep codes are generated when all other expansion cards are absent, consult your system manufacturer's technical support. ● If beep codes are not generated when all other expansion cards are absent, one of the add-in cards is causing the malfunction. Insert the cards back into the system one at a time until the problem happens again. This will reveal the malfunctioning card.
8	If the system video adapter is an add-in card, replace or reseat the video adapter. If the video adapter is an integrated part of the system board, the board may be faulty.

6.4 AMI BIOS Post Code

Checkpoint	Description
03	Disable NMI, Parity, video for EGA, and DMA controllers. Initialize BIOS, POST, Runtime data area. Also initialize BIOS modules on POST entry and GPNV area. Initialize CMOS as mentioned in the Kernel Variable "wCMOSFlags."
04	Check CMOS diagnostic byte to determine if battery power is OK and CMOS checksum is OK. Verify CMOS checksum manually by reading storage area. If the CMOS checksum is bad, update CMOS with power-on default values and clear passwords. Initialize status register A. Initialize data variables that are based on CMOS setup questions. Initialize both the 8259 compatible PICs in the system
05	Initializes the interrupt controlling hardware (generally PIC) and interrupt vector table.
06	Do R/W test to CH-2 count reg. Initialize CH-0 as system timer. Install the POSTINT1Ch handler. Enable IRQ-0 in PIC for system timer interrupt. Traps INT1Ch vector to "POSTINT1ChHandlerBlock."
07	Fixes CPU POST interface calling pointer.
08	Initializes the CPU. The BAT test is being done on KBC. Program the keyboard controller command byte is being done after Auto detection of KB/MS using AMI KB-5.
C0	Early CPU Init Start -- Disable Cache -- Init Local APIC.
C1	Set up boot strap processor Information.
C2	Set up boot strap processor for POST.
C5	Enumerate and set up application processors.
C6	Re-enable cache for boot strap processor.
C7	Early CPU Init Exit.
0A	Initializes the 8042 compatible Key Board Controller.
0B	Detects the presence of PS/2 mouse.
0C	Detects the presence of Keyboard in KBC port.
0E	Testing and initialization of different Input Devices. Also, update the Kernel Variables. Traps the INT09h vector, so that the POST INT09h handler gets control for IRQ1. Uncompress all available language, BIOS logo, and Silent logo modules.
13	Early POST initialization of chipset registers.
20	Relocate System Management Interrupt vector for all CPU in the system.
24	Uncompress and initialize any platform specific BIOS modules. GPNV is initialized at this checkpoint.
2A	Initializes different devices through DIM. See DIM Code Checkpoints section of document for more information.
2C	Initializes different devices. Detects and initializes the video adapter installed in the system that have optional ROMs.
2E	Initializes all the output devices.
31	Allocate memory for ADM module and uncompress it. Give control to ADM module for initialization. Initialize language and font modules for ADM. Activate ADM module.
33	Initializes the silent boot module. Set the window for displaying text information.

Motherboard Manual

Checkpoint	Description
37	Displaying sign-on message, CPU information, setup key message, and any OEM specific information.
38	Initializes different devices through DIM. See DIM Code Checkpoints section of document for more information. USB controllers are initialized at this point.
39	Initializes DMAC-1 & DMAC-2.
3A	Initialize RTC date/time.
3B	Test for total memory installed in the system. Also, Check for DEL or ESC keys to limit memory test. Display total memory in the system.
3C	Mid POST initialization of chipset registers.
40	Detect different devices (Parallel ports, serial ports, and coprocessor in CPU, etc.) successfully installed in the system and update the BDA, EBDA...etc.
52	Updates CMOS memory size from memory found in memory test. Allocates memory for Extended BIOS Data Area from base memory. Programming the memory hole or any kind of implementation that needs an adjustment in system RAM size if needed.
60	Initializes NUM-LOCK status and programs the KBD typematic rate.
75	Initialize Int-13 and prepare for IPL detection.
78	Initializes IPL devices controlled by BIOS and option ROMs.
7C	Generate and write contents of ESCD in NVRam.
84	Log errors encountered during POST.
85	Display errors to the user and gets the user response for error.
87	Execute BIOS setup if needed / requested. Check boot password if installed.
8C	Late POST initialization of chipset registers.
8D	Build ACPI tables (if ACPI is supported).
8E	Program the peripheral parameters. Enable/Disable NMI as selected.
90	Initialization of system management interrupt by invoking all handlers. Please note this checkpoint comes right after checkpoint 20h.
A1	Clean-up work needed before booting to OS.
A2	Takes care of runtime image preparation for different BIOS modules. Fill the free area in F000h segment with 0FFh. Initializes the Microsoft IRQ Routing Table. Prepares the runtime language module. Disables the system configuration display if needed.
A4	Initialize runtime language module. Display boot option popup menu.
A7	Displays the system configuration screen if enabled. Initialize the CPU's before boot, which includes the programming of the MTRR's.
A9	Wait for user input at config display if needed.
AA	Uninstall POST INT1Ch vector and INT09h vector.
AB	Prepare BBS for Int 19 boot. Init MP tables.
AC	End of POST initialization of chipset registers. De-initializes the ADM module.
B1	Save system context for ACPI. Prepare CPU for OS boot including final MTRR values.
00	Passes control to OS Loader (typically INT19h).

6.5 TROUBLESHOOTING

Probable	Solution
1. There is no power in the system. Power LED does not shine; the fan of the power supply does not work 2. Indicator light on keyboard does not shine.	1. Make sure power cable is securely plugged in. 2. Replace cable. 3. Contact technical support.
System is inoperative. Keyboard lights are on, power indicator lights are lit, and hard drives are running.	Using even pressure on both ends of the DIMM, press down firmly until the module snaps into place.
System does not boot from a hard disk drive, but can be booted from optical drive.	1. Check cable running from disk to disk controller board. Make sure both ends are securely plugged in; check the drive type in the standard CMOS setup. 2. Backing up the hard drive is extremely important. All hard disks are capable of breaking down at any time.
System only boots from an optical drive. Hard disks can be read, applications can be used, but system fails to boot from a hard disk.	1. Back up data and applications files. 2. Reformat the hard drive. Re-install applications and data using backup disks.
Screen message shows "Invalid Configuration" or "CMOS Failure."	Review system's equipment. Make sure correct information is in setup.
System cannot boot after user installs a second hard drive.	1. Set master/slave jumpers correctly. 2. Run SETUP program and select correct drive types. Call the drive manufacturers for compatibility with other drives.

APPENDIX: SPEC IN OTHER LANGUAGES

GERMAN

<i>Spezifikationen</i>		
CPU	Sockel AM3+ AMD Sempron / Phenom II / Athlon II / FX Prozessoren	Die AMD 64-Architektur unterstützt eine 32-Bit- und 64-Bit-Datenverarbeitung Unterstützt Hyper Transport 3.0
FSB	Unterstützt HyperTransport 3.0 mit einer Bandbreite von bis zu 4.8 GT/s	
Chipsatz	AMD 970 AMD SB950	
Super E/A	ITE 8728 Bietet die häufig verwendeten alten Super E/A-Funktionen. Low Pin Count-Schnittstelle	Umgebungskontrolle, Hardware-Überwachung Lüfterdrehzahl-Controller "Smart Guardian"-Funktion von ITE
Arbeitsspeicher	DDR3 DIMM-Steckplätze x 4 Max. 32GB Arbeitsspeicher Jeder DIMM unterstützt 512MB/ 1GB/2GB/4GB/8GB DDR3.	Dual-Kanal DDR3 Speichermodul Unterstützt DDR3 800/1066/1333/1600/1866 Unterstützt DDR3 2000 (OC)
SATA III	Integrierter Serial ATA-Controller	Datentransferrate bis zu 6 Gb/s Konform mit der SATA-Spezifikation Version 3.0 Unterstützt RAID 0,1,5,10
LAN	Realtek RTL 8111E	10 / 100 / 1000 Mb/s Auto-Negotiation Halb-/ Vollduplex-Funktion
Audio-Codec	ALC892	7.1-Kanal-Audioausgabe Unterstützt High-Definition Audio
USB3.0	Asmedia ASM1042	Datenübertragungsraten bis zu 600 MB / s
IEEE 1394	VIA VT6315N	1394a
Steckplätze	PCI Steckplatz x2 PCI Express Gen2 x1 Steckplatz x2 PCI Express Gen2 x16 Steckplatz x2	
Onboard-Anschluss	SATA-Anschluss x5 Fronttafelanschluss x1 Front-Audioanschluss x1	Jeder Anschluss unterstützt 1 SATA-Laufwerk Unterstützt die Fronttafel-funktionen Unterstützt die Fronttafel-Audioanschlussfunktion

Spezifikationen			
	S/PDIF Ausgangsanschluss	x1	Unterstützt die digitale Audioausgabefunktion
	Verbraucher-IR Anschluss	x1	
	CPU-Lüfter-Sockel	x1	CPU-Lüfterstromversorgungsanschluss (mit Smart Fan-Funktion)
	System-Lüfter-Sockel	x2	
	"CMOS löschen"-Sockel	x1	System-Lüfter-Stromversorgungsanschluss
	USB2.0-Anschluss	x2	Jeder Anschluss unterstützt 2 Fronttafel-USB2.0-Anschlüsse
	IEEE 1394-Anschluss	x1	
	Druckeranschluss Anschluss	x1	Jeder Anschluss unterstützt 1 Druckeranschluss
	Serieller Anschluss	x1	
	Stromanschluss (24-polig)	x1	
	Stromanschluss (4-polig)	x1	
Rückseiten-E/A	PS/2-Tastatur / Maus	x1	
	Optisches + Coaxial S/PDIF Heraus	x1	
	1394-Anschluss	x1	
	eSATA Anschluss	x1	
	LAN-Anschluss	x1	
	USB2.0-Anschluss	x6	
	USB3.0-Anschluss	x2	
Audioanschluss	x6		
Platinengröße	305 mm (B) X 225 mm (L)		
OS-Unterstützung	Windows XP / Vista / 7		Biostar behält sich das Recht vor, ohne Ankündigung die Unterstützung für ein Betriebssystem hinzuzufügen oder zu entfernen.

FRENCH

SPEC		
UC	Socket AM3+ Processeurs AMD Sempron / Phenom II / Athlon II / FX	L'architecture AMD 64 permet le calcul 32 et 64 bits Prend en charge Hyper Transport 3.0
Bus frontal	Prend en charge Hyper Transport 3.0 jusqu'à une bande passante de 4.8 GT/s	
Chipset	AMD 970 AMD SB950	
Super E/S	ITE 8728 Fournit la fonctionnalité de Super E/S patrimoniales la plus utilisée. Interface à faible compte de broches	Initiatives de contrôle environnementales, Moniteur de matériel Contrôleur de vitesse de ventilateur Fonction "Gardien intelligent" de l'ITE
Mémoire principale	Fentes DDR3 DIMM x 4 Capacité mémoire maximale de 32Go Chaque DIMM prend en charge des DDR3 de 512Mo/1Go/2Go/4Go/8Go	Module de mémoire DDR3 à mode à double voie Prend en charge la DDR3 800/1066/1333/1600/1866 Prend en charge la DDR3 2000 (OC)
SATA III	Contrôleur Serial ATA intégré	Taux de transfert jusqu'à 6 Go/s. Conforme à la spécification SATA Version 3.0 Prise en charge RAID 0,1,5,10
LAN	Realtek RTL 8111E	10 / 100 / 1000 Mb/s négociation automatique Half / Full duplex capability
Codec audio	ALC892	Sortie audio à 7.1 voies Prise en charge de l'audio haute définition
USB3.0	Asmedia ASM1042	Taux de transfert de données jusqu'à 600 Mo / s
IEEE 1394	VIA VT6315N	1394a
Fentes	Fente PCI x2 Fente PCI Express Gen2 x1 x2 Fente PCI Express Gen2 x16 x2	
Connecteur embarqué	Connecteur SATA x5 Connecteur du panneau avant x1 Connecteur Audio du panneau avant x1 Connecteur de sortie S/PDIF x1	Chaque connecteur prend en charge 1 périphérique SATA Prend en charge les équipements du panneau avant Prend en charge la fonction audio du panneau avant Prend en charge la fonction de sortie audio numérique

SPEC		
	Connecteur de IR du consommateur x1	
	Embase de ventilateur UC x1	Alimentation électrique du ventilateur UC (avec fonction de ventilateur intelligent)
	Embase de ventilateur système x2	Alimentation électrique du ventilateur système
	Embase d'effacement CMOS x1	
	Connecteur USB2.0 x2	Chaque connecteur prend en charge 2 ports USB2.0 de panneau avant
	Connecteur IEEE 1394 x1	
	Connecteur de Port d'imprimante x1	Chaque connector prend en charge 1 Port d'imprimante
	Port série x1	
	Connecteur d'alimentation (24 broches) x1	
	Connecteur d'alimentation (4 broches) x1	
E/S du panneau arrière	Clavier / Souris PS/2 x1	
	Coaxial + Optique Sortie S/PDIF x1	
	Port 1394 x1	
	Port eSATA x1	
	Port LAN x1	
	Port USB2.0 x6	
	Port USB3.0 x2	
Fiche audio x6		
Dimensions de la carte	305 mm (l) X 225 mm (H)	
Support SE	Windows XP / Vista / 7	Biostar se réserve le droit d'ajouter ou de supprimer le support de SE avec ou sans préavis.

ITALIAN

SPECIFICA		
CPU	Socket AM3+ Processori AMD Sempron / Phenom II / Athlon II / FX	L'architettura AMD 64 abilita la computazione 32 e 64 bit Supporto di Hyper Transport 3.0
FSB	Supporto di HyperTransport 3.0 fino a 4.8 GT/s di larghezza di banda	
Chipset	AMD 970 AMD SB950	
Super I/O	ITE 8728 Fornisce le funzionalità legacy Super I/O usate più comunemente. Interfaccia LPC (Low Pin Count)	Funzioni di controllo dell'ambiente: Monitoraggio hardware Controller velocità ventolina Funzione "Smart Guardian" di ITE
Memoria principale	Alloggi DIMM DDR3 x 4 Capacità massima della memoria 32GB Ciascun DIMM supporta DDR3 512MB/1GB/2GB/4GB/8GB	Modulo di memoria DDR3 a canale doppio Supporto di DDR3 800/1066/1333/1600/1866 Supporto di DDR3 2000 (OC)
SATA III	Controller Serial ATA integrato	Velocità di trasferimento dei dati fino a 6 Gb/s. Compatibile specifiche SATA Versione 3.0 Supporto RAID 0,1,5,10
LAN	Realtek RTL 8111E	Negoziazione automatica 10 / 100 / 1000 Mb/s Capacità Half / Full Duplex
Codec audio	ALC892	Uscita audio 7.1 canali Supporto audio High-Definition (HD)
USB3.0	Asmedia ASM1042	Velocità di trasferimento dati fino a 600 MB / s
IEEE 1394	VIA VT6315N	1394a
Alloggi	Alloggio PCI x2 Alloggio PCI Express Gen2 x1 x2 Alloggio PCI Express Gen2 x16 x2	
Connettori su scheda	Connettore SATA x5 Connettore pannello frontale x1 Connettore audio frontale x1 Connettore output S/PDIF x1 Connettore IR del consumatore x1	Ciascun connettore supporta 1 unità SATA Supporta i servizi del pannello frontale Supporta la funzione audio pannello frontale Supporta la funzione d'output audio digitale

SPECIFICA			
	Collettore ventolina CPU	x1	Alimentazione ventolina CPU (con funzione Smart Fan)
	Collettore ventolina sistema	x2	Alimentazione ventolina di sistema
	Collettore cancellazione CMOS	x1	
	Connettore USB2.0	x2	Ciascun connettore supporta 2 porte USB2.0 pannello frontale
	Connettore IEEE 1394	x1	
	Connettore Porta stampante	x1	Ciascun connettore supporta 1 Porta stampante
	Porta seriale	x1	
	Connettore alimentazione (24 pin)	x1	
	Connettore alimentazione (4 pin)	x1	
I/O pannello posteriore	Tastiera / Mouse PS/2	x1	
	Coaxial + Ottico S/PDIF Fuori	x1	
	Porta 1394	x1	
	Porta eSATA	x1	
	Porta LAN	x1	
	Porta USB2.0	x6	
	Porta USB3.0	x2	
	Connettore audio	x6	
Dimensioni scheda	305 mm (larghezza) x 225 mm (altezza)		
Sistemi operativi supportati	Windows XP / Vista / 7		Biostar si riserva il diritto di aggiungere o rimuovere il supporto di qualsiasi sistema operativo senza preavviso.

SPANISH

<i>Especificación</i>		
CPU	Conector AM3+ Procesadores AMD Sempron / Phenom II / Athlon II / FX	La arquitectura AMD 64 permite el procesado de 32 y 64 bits Soporta las tecnologías Hyper Transport 3.0
FSB	Admite HyperTransport 3.0 con un ancho de banda de hasta 4.8 GT/s	
Conjunto de chips	AMD 970 AMD SB950	
Súper E/S	ITE 8728 Le ofrece las funcionalidades heredadas de uso más común Súper E/S. Interfaz de cuenta Low Pin	Iniciativas de control de entorno, Monitor hardware Controlador de velocidad de ventilador Función "Guardia inteligente" de ITE
Memoria principal	Ranuras DIMM DDR3 x 4 Capacidad máxima de memoria de 32GB Cada DIMM admite DDR de 512MB/1GB/2GB/4GB/8GB	Módulo de memoria DDR3 de canal Doble Admite DDR3 de 800/1066/1333/1600/1866 Admite DDR3 de 2000 (OC)
SATA III	Controlador ATA Serie Integrado	Tasas de transferencia de hasta 6 Gb/s. Compatible con la versión SATA 3.0 Admite RAID 0,1,5,10
Red Local	Realtek RTL 8111E	Negociación de 10 / 100 / 1000 Mb/s Funciones Half / Full dúplex
Códecs de sonido	ALC892	Salida de sonido de 7.1 canales Soporte de sonido de Alta Definición
USB3.0	Asmedia ASM1042	Tasas de transferencia de datos hasta 600 MB / s
IEEE 1394	VIA VT6315N	1394a
Ranuras	Ranura PCI X2 Ranura PCI express Gen2 x1 X2 Ranura PCI express Gen2 x16 X2	
Conectores en placa	Conector SATA X5 Conector de panel frontal X1 Conector de sonido frontal X1 Conector de salida S/PDIF X1 Conector de IR del consumidor X1	Cada conector soporta 1 dispositivos SATA Soporta instalaciones en el panel frontal Soporta funciones de sonido en el panel frontal Soporta función de salida de sonido digital

Especificación			
	Cabecera de ventilador de CPU	X1	Fuente de alimentación de ventilador de CPU (con función Smart Fan)
	Cabecera de ventilador de sistema	X2	Fuente de alimentación de ventilador de sistema
	Cabecera de borrado de CMOS	X1	
	Conector USB2.0	X2	Cada conector soporta 2 puertos USB2.0 frontales
	Cabecera IEEE 1394	x1	
	Conector Puerto de impresora	X1	Cada conector soporta 1 Puerto de impresora
	Puerto serie	X1	
	Conector de alimentación (24 patillas)	X1	
	Conector de alimentación (4 patillas)	X1	
Panel trasero de E/S	Teclado / Ratón PS/2	X1	
	Coaxial + óptico Salida S/PDIF	x1	
	Puerto 1394	x1	
	Puerto eSATA	X1	
	Puerto de red local	X1	
	Puerto USB2.0	X6	
	Puerto USB3.0	X2	
	Conector de sonido	X6	
Tamaño de la placa	305 mm. (A) X 225 mm. (H)		
Soporte de sistema operativo	Windows XP / Vista / 7		Biostar se reserva el derecho de añadir o retirar el soporte de cualquier SO con o sin aviso previo.

PORTUGUESE

ESPECIFICAÇÕES		
CPU	Socket AM3+ Processadores AMD Sempron / Phenom II / Athlon II / FX	A arquitetura AMD 64 permite uma computação de 32 e 64 bits Suporta as tecnologias Hyper Transport 3.0
FSB	Suporta a tecnologia HyperTransport 3.0 com uma largura de banda até 4.8 GT/s	
Chipset	AMD 970 AMD SB950	
Especificação do Super I/O	ITE 8728 Proporciona as funcionalidades mais utilizadas em termos da especificação Super I/O. Interface LPC (Low Pin Count).	Iniciativas para controlo do ambiente Monitorização do hardware Controlador da velocidade da ventoinha Função "Smart Guardian" da ITE
Memória principal	Ranhuras DIMM DDR3 x 4 Capacidade máxima de memória: 32GB Cada módulo DIMM suporta uma memória DDR3 de 512MB/1GB/2GB/4GB/8GB	Módulo de memória DDR3 de canal duplo Suporta módulos DDR3 800/1066/1333/1600/1866 Suporta módulos DDR3 2000 (OC)
SATA III	Controlador Serial ATA integrado	Velocidades de transmissão de dados até 6 Gb/s. Compatibilidade com a especificação SATA versão 3.0 Suporta as funções RAID 0,1,5,10
LAN	Realtek RTL 8111E	Auto negociação de 10 / 100 / 1000 Mb/s Capacidade semi/full-duplex
Codec de som	ALC892	Saída de áudio de 7.1 canais Suporta a especificação High-Definition Audio
USB3.0	Asmedia ASM1042	Taxas de transferência de dados até 600 MB / s
IEEE 1394	VIA VT6315N	1394a
Ranhuras	Ranhura PCI x2 Ranhura PCI Express Gen2 x1 x2 Ranhura PCI Express Gen2 x16 x2	
Conectores na placa	Conector SATA x5 Conector do painel frontal x1 Conector de áudio frontal x1	Cada conector suporta 1 dispositivo SATA Para suporte de várias funções no painel frontal Suporta a função de áudio no painel frontal

ESPECIFICAÇÕES			
	Conector de saída S/PDIF	x1	Suporta a saída de áudio digital
	Conector de IR do consumidor	x1	
	Conector da ventoinha da CPU	x1	Alimentação da ventoinha da CPU (com a função Smart Fan)
	Conector da ventoinha do sistema	x2	Alimentação da ventoinha do sistema
	Conector para limpeza do CMOS	x1	
	Conector USB2.0	x2	Cada conector suporta 2 portas USB2.0 no painel frontal
	Conector IEEE 1394	x1	
	Conector da para impressora	x1	Cada conector suporta 1 Porta para impressora
	Porta série	x1	
	Conector de alimentação (24 pinos)	x1	
	Conector de alimentação (4 pinos)	x1	
Entradas/Saídas no painel traseiro	Teclado / Rato PS/2	x1	
	Coaxial + ótico Saída S/PDIF	x1	
	Porta 1394	x1	
	Porta eSATA	x1	
	Porta LAN	x1	
	Porta USB2.0	x6	
	Porta USB3.0	x2	
	Tomada de áudio	x6	
Tamanho da placa	305 mm (L) X 225 mm (A)		
Sistemas operativos suportados	Windows XP / Vista / 7		A Biostar reserva-se o direito de adicionar ou remover suporte para qualquer sistema operativo com ou sem aviso prévio.

POLISH

SPEC		
Procesor	Socket AM3+ AMD Sempron / Phenom II / Athlon II / FX Procesory	Architektura AMD 64 umożliwia przetwarzanie 32 i 64 bitowe Obsługa Hyper Transport 3.0
FSB	Obsługa HyperTransport 3.0 o szerokości pasma do 4.8 GT/s	
Chipset	AMD 970 AMD SB950	
Pamięć główna	Gniazda DDR3 DIMM x 4 Maks. wielkość pamięci 32GB Każde gniazdo DIMM obsługuje moduły 512MB/1GB/2GB/4GB/8GB DDR3	Moduł pamięci DDR3 z trybem podwójnego kanału Obsługa DDR3 800/1066/1333/1600/1866 Obsługa DDR3 2000 (OC)
Super I/O	ITE 8728 Zapewnia najbardziej powszechne funkcje Super I/O. Interfejs Low Pin Count	Funkcje kontroli warunków pracy, Monitor H/W Kontroler prędkości wentylatora Funkcja ITE "Smart Guardian"
SATA III	Zintegrowany kontroler Serial ATA	Transfer danych do 6 Gb/s. Zgodność ze specyfikacją SATA w wersji 3.0 Obsługa RAID 0,1,5,10
LAN	Realtek RTL 8111E	10 / 100 / 1000 Mb/s z automatyczną negocjacją szybkości Działanie w trybie połowicznego/pełnego duplexu
Kodek dźwiękowy	ALC892	7.1 kanałowe wyjście audio Obsługa High-Definition Audio
USB3.0	Asmedia ASM1042	Cena transferu danych do 600 MB / s
IEEE 1394	VIA VT6315N	1394a
Gniazda	Gniazdo PCI x2 Gniazdo PCI Express Gen2 x1 x2 Gniazdo PCI Express Gen2 x16 x2	
Złącza wbudowane	Złącze SATA x5 Złącze panela przedniego x1 Przednie złącze audio x1 Złącze wyjścia S/PDIF x1	Każde złącze obsługuje 1 urządzenie SATA Obsługa elementów panela przedniego Obsługa funkcji audio na panelu przednim Obsługa funkcji cyfrowego wyjścia audio

SPEC			
	Złącze Konsument IR	x1	
	Złącze główkowe wentylatora procesora	x1	Zasilanie wentylatora procesora (z funkcją Smart Fan)
	Złącze główkowe wentylatora systemowego	x2	Zasilanie wentylatora systemowego
	Złącze główkowe kasowania CMOS	x1	
	Złącze USB2.0	x2	Każde złącze obsługuje 2 porty USB2.0 na panelu przednim
	Złącze IEEE 1394	x1	
	Złącze Port drukarki	x1	Każde złącze obsługuje 1 Port drukarki
	Port szeregowy	x1	
	Złącze zasilania (24 pinowe)	x1	
	Złącze zasilania (4 pinowe)	x1	
Back Panel I/O	Klawiatura / Mysz PS/2	x1	
	Optyczny +coaxial wyjścia S/PDIF	x1	
	Port 1394	x1	
	Port eSATA	x1	
	Port LAN	x1	
	Port USB2.0	x6	
	Port USB3.0	x2	
	Gniazdo audio	x6	
Wymiary płyty	305 mm (S) X 225 mm (W)		
Obsługa systemu operacyjnego	Windows XP / Vista / 7		Biostar zastrzega sobie prawo dodawania lub odwoływania obsługi dowolnego systemu operacyjnego bez powiadomienia.

RUSSIAN

СПЕЦ		
CPU (центральный процессор)	Гнездо AM3+ Процессоры AMD Sempron / Phenom II / Athlon II / FX	Архитектура AMD 64 разрешать обработка данных на 32 и 64 бит Поддержка Hyper Transport 3.0
FSB	Поддержка HyperTransport 3.0 с пропускной способностью до 4.8 GT/s	
Набор микросхем	AMD 970 AMD SB950	
Основная память	Слоты DDR3 DIMM x 4 Максимальная ёмкость памяти 32ГБ Каждый модуль DIMM поддерживает 512МБ/1ГБ/2ГБ/4ГБ/8ГБ DDR3	Модуль памяти с двухканальным режимом DDR3 Поддержка DDR3 800/1066/1333/1600/1866 Поддержка DDR3 2000 (OC)
Super I/O	ITE 8728 Обеспечивает наиболее используемые действующие функциональные возможности Super I/O. Интерфейс с низким количеством выводов	Инициативы по охране окружающей среды, Аппаратный монитор Регулятор скорости Функция ITE "Smart Guardian" (Интеллектуальная защита)
SATA III	Встроенное последовательное устройство управления ATA	скорость передачи данных до 6 гигабит/с. Соответствие спецификации SATA версия 3.0 Поддержка RAID 0,1,5,10
Локальная сеть	Realtek RTL 8111E	Автоматическое согласование 10 / 100 / 1000 Мб/с Частичная / полная дуплексная способность
Звуковой кодек	ALC892	Звуковая поддержка High-Definition 7.1канальный звуковой выход
USB3.0	Asmedia ASM1042	скорости передачи данных до 600 МБ / с
IEEE 1394	VIA VT6315N	1394a
Слоты	Слот PCI x2 Слот PCI Express Gen2 x1 x2 Слот PCI Express Gen2 x16 x2	
Встроенный разъём	Разъём SATA x5 Разъём на лицевой панели x1 Входной звуковой разъём x1 Разъём вывода для S/PDIF x1	Каждый разъём поддерживает 1 устройство SATA Поддержка устройств на лицевой панели Поддержка звуковых функций на лицевой панели Поддержка вывода цифровой звуковой функции

СПЕЦ			
	Разъём едока ИКЫЙ	x1	<p>Источник питания для вентилятора центрального процессора (с функцией интеллектуального вентилятора)</p> <p>Источник питания для вентилятора системы</p> <p>Каждый разъём поддерживает 2 USB2.0-порта на лицевой панели</p> <p>Каждый разъём поддерживает 1 Порт подключения принтера</p>
	Контактирующее приспособление вентилятора центрального процессора	x1	
	Контактирующее приспособление вентилятора системы	x2	
	Открытое контактирующее приспособление CMOS	x1	
	USB2.0-разъём	x2	
	IEEE 1394-разъём	x1	
	Разъём Порт подключения принтера	x1	
	Последовательный порт	x1	
	Разъем питания (24 вывод)	x1	
	Разъем питания (4 вывод)	x1	
Задняя панель средств ввода-вывода	Клавиатура / Мышь PS/2	x1	
	Оптически + coaxial вывода для S/PDIF	x1	
	1394-порт	x1	
	eSATA порт	x1	
	Порт LAN	x1	
	USB2.0-порт	x6	
	USB3.0-порт	x2	
	Гнездо для подключения наушников	x6	
Размер панели	305 мм (Ш) X 225 мм (В)		
Поддержка OS	Windows XP / Vista / 7		Biostar сохраняет за собой право добавлять или удалять средства обеспечения для OS с или без предварительного уведомления.

ARABIC

المواصفات		
وحدة المعالجة المركزية	AM3+ مقبس AMD Sempron / Phenom II / Athlon II معالجات / FX	إجراء العمليات الحاسوبية بسرعة 32 و 64 بت AMD 64 تمكين تقنية و 3.0 Hyper Transport تدعم تقنية
النافذ الأمامي الجانبي	4.8 GT/s يتردد يصل إلى 3.0 Hyper Transport تدعم تقنية	
مجموعة الشرائح	AMD 970 AMD SB950	
الذاكرة الرئيسية	قناة DDR3 DIMM سعة ذاكرة قصوى 32 جيجا بايت ميغا 512/سعة DDR3 تدعم ذاكرة من نوع DIMM تدعم كل قناة بايت و 1/2 و 4/8 جيجا بايت	عدد 4 مزدوجة القناة DDR3 وحدة ذاكرة سعات DDR3 1866/1600/1333/1066/800 تدعم الذاكرة من نوع ميغا بايت 2000 (OC) ساعات DDR3 نوع من الذاكرة تدعم
Super I/O	ITE 8728 الأكثر استخداماً Super I/O توفر وظيفة Low Pin Count Interface تدعم تقنية	وسائل التحكم في البيئة: مراقب لمعرفة حالة الأجهزة مراقب في سرعة المروحة من ITE "Smart Guardian" وظيفة
SATA III	متكامل Serial ATA متحكم	نقل البيانات بسرعات تصل إلى 6 جيجابت/ثانية. 3.0 الإصدار SATA مطابقة لمواصفات RAID 0,1,5,10 تدعم تقنية
شبكة داخلية	Realtek RTL 8111E	تقويض ثنائي 10/100 ميغا بايت / ثنائي و 1 جيجا بت/ثانية إمكانية النقل المزدوج الكامل/الصفى
كوديك الصوت	ALC892	تدعم تقنية الصوت علي التعريف من 7.1 قنوات لخرج الصوت
USB 3.0	Asmedia ASM1042	ثانوية / بايست ميغا 600 إلى تصل بيانات نقل معدلات
IEEE 1394	VIA VT6315N	1394a
الفتحات	قناة PCI قناة PCI Express Gen2 x1 قناة PCI Express Gen2 x16	عدد 2 عدد 2 عدد 2
المنافذ على سطح اللوحة	منفذ SATA منفذ اللوحة الأمامية منفذ الصوت الأمامي منفذ خرج S/PDIF منفذ ر الأحم تحسنت مستهلكة وصلة مروحة وحدة المعالجة المركزية	عدد 5 عدد 1 عدد 1 عدد 1 عدد 1 عدد 1
	Smart Fan	توصيل الطاقة لمروحة وحدة المعالجة مع وظيفة

المواصفات		
توصيل الطاقة لمروحة النظام	عدد 2	وصلة مروحة النظام
	عدد 1	وصلة مسح CMOS
يدعم كل منفذ قمتحتي USB2.0 باللوحة الامامية	عدد 2	منفذ USB2.0
	عدد 1	منفذ IEEE 1394
	عدد 1	منفذ طباعة
	عدد 1	منفذ تسلسلي
	عدد 1	منفذ توصيل الطاقة (24دبوس)
	عدد 1	منفذ توصيل الطاقة (4دبابيس)
	عدد 1	لوحة مفاتيح / ملوس PS/2
	عدد 1	محور متحد +بصرية منفذ خرج S/PDIF
	عدد 1	منفذ 1394
	عدد 1	منفذ eSATA
	عدد 1	منفذ شبكة اتصال محلية
	عدد 6	منفذ USB2.0
	عدد 2	منفذ USB3.0
	عدد 6	مقيس صوت
		حجم اللوحة
		305 مم (عرض) X 225 مم (ارتفاع)
بحقها في اضافة أو ازالة الدعم لأي نظام تشغيل بإخطار أو بدون Biostar تحفظ بإخطار .		دعم أنظمة التشغيل
		Windows XP / Vista / 7

JAPANESE

仕様		
CPU	Socket AM3+ AMD Sempron / Phenom II / Athlon II / FX プロセッサ	AMD 64アーキテクチャでは、32ビットと64ビット計算が可能です ハイバートランスポート3.0をサポートします
FSB	4.8 GT/sのバンド幅までハイバートランスポート3.0をサポートします	
チップセット	AMD 970 AMD SB950	
メインメモリ	DDR3 DIMMスロット x 4 最大メモリ容量32GB 各DIMMは 512MB/1GB/2GB/4GB/8GB DDR3をサポート	デュアル チャンネルモードDDR3メモリモジュール DDR3 800/1066/1333/1600/1866 をサポート DDR3 2000 (OC) をサポート
Super I/O	ITE 8728 もともと一般に使用されるレガシーSuper I/O機能を採用しています。 低ピンカウントインターフェイス	環境コントロールイニシアチブ、 H/Wモニター ファン速度コントローラ/ モニター ITEの「スマートガーディアン」機能
SATA III	統合シリアルATAコントローラ	最高6 Gb/秒のデータ転送速度 SATAバージョン3.0仕様に準拠。 RAID 0,1,5,10のサポート
LAN	Realtek RTL 8111E	10 / 100 / 1000 Mb/秒のオートネゴシエーション 半/全二重機能
サウンド Codec	ALC892	ハイデフィニションオーディオのサポート 7.1 チャンネルオーディオアウト
USB3.0	Asmedia ASM1042	データ転送速度最大600 MB /秒の
IEEE 1394	VIA VT6315N	1394a
スロット	PCIスロット x2 PCI Express Gen2 x1スロット x2 PCI Express Gen2 x16スロット x2	
オンボードコネクタ	SATAコネクタ x5 フロントパネルコネクタ x1 フロントオーディオコネクタ x1 S/PDIFアウトコネクタ x1 消費者IRコネクタ x1	各コネクタは1つのSATAデバイスをサポートします フロントパネル機能をサポートします フロントパネルオーディオ機能をサポートします デジタルオーディオアウト機能をサポートします

仕様			
	CPUファンヘッダ	x1	CPUファン電源装置(スマートファン機能を搭載)
	システムファンヘッダ	x2	システムファン電源装置
	CMOSクリアヘッダ	x1	
	USB2.0コネクタ	x2	各コネクタは2つのフロントパネルUSB2.0ポートをサポートします
	IEEE 1394コネクタ	x1	
	プリンタポートコネクタ	x1	各コネクタは1つのプリンタポートをサポートします
	シリアルポート	x1	
	電源コネクタ(24ピン)	x1	
	電源コネクタ(4ピン)	x1	
背面パネル I/O	PS/2キーボード / マウス	x1	
	光学+coaxial S/PDIFアウト	x1	
	1394ポート	x1	
	eSATAポート	x1	
	LANポート	x1	
	USB2.0ポート	x6	
	USB3.0ポート	x2	
	オーディオジャック	x6	
ボードサイズ	305 mm (幅) X 225 mm (高さ)		
OSサポート	Windows XP / Vista / 7		Biostarは事前のサポートなしにOSサポートを追加または削除する権利を留保します。

2013/02/07