

## **FCC Information and Copyright**

This equipment has been tested and found to comply with the limits of a Class B digital device, pursuant to Part 15 of the FCC Rules. These limits are designed to provide reasonable protection against harmful interference in a residential installation. This equipment generates, uses and can radiate radio frequency energy and, if not installed and used in accordance with the instructions, may cause harmful interference to radio communications. There is no guarantee that interference will not occur in a particular installation.

The vendor makes no representations or warranties with respect to the contents here and specially disclaims any implied warranties of merchantability or fitness for any purpose. Further the vendor reserves the right to revise this publication and to make changes to the contents here without obligation to notify any party beforehand.

Duplication of this publication, in part or in whole, is not allowed without first obtaining the vendor's approval in writing.

The content of this user's manual is subject to be changed without notice and we will not be responsible for any mistakes found in this user's manual. All the brand and product names are trademarks of their respective companies.

---

---

## Table of Contents

---

---

<b>Chapter 1: Introduction</b> .....	<b>3</b>
<b>1.1 Before You Start</b> .....	3
<b>1.2 Package Checklist</b> .....	3
<b>1.3 Motherboard Features</b> .....	4
<b>1.4 Rear Panel Connectors</b> .....	6
<b>1.5 Motherboard Layout</b> .....	7
<b>Chapter 2: Hardware Installation</b> .....	<b>8</b>
<b>2.1 Installing Central Processing Unit (CPU)</b> .....	8
<b>2.2 FAN Headers</b> .....	10
<b>2.3 Installing System Memory</b> .....	11
<b>2.4 Connectors and Slots</b> .....	13
<b>Chapter 3: Headers &amp; Jumpers Setup</b> .....	<b>15</b>
<b>3.1 How to Setup Jumpers</b> .....	15
<b>3.2 Detail Settings</b> .....	15
<b>Chapter 4: RAID Functions</b> .....	<b>22</b>
<b>4.1 Operation System</b> .....	22
<b>4.2 Raid Arrays</b> .....	22
<b>4.3 How RAID Works</b> .....	22
<b>Chapter 5: OverClock Quick Guide</b> .....	<b>25</b>
<b>5.1 T-Power Introduction</b> .....	25
<b>5.2 T-Power BIOS Feature</b> .....	26
<b>5.3 T-Power Windows Feature</b> .....	34
<b>Chapter 6: Useful Help</b> .....	<b>43</b>
<b>6.1 Driver Installation Note</b> .....	43
<b>6.2 Award BIOS Beep Code</b> .....	44
<b>6.3 Extra Information</b> .....	44
<b>6.4 Troubleshooting</b> .....	46
<b>Appendencies: SPEC In Other Language</b> .....	<b>48</b>
<b>German</b> .....	48
<b>France</b> .....	50
<b>Italian</b> .....	52
<b>Spanish</b> .....	54
<b>Portuguese</b> .....	56
<b>Polish</b> .....	58
<b>Russian</b> .....	60
<b>Arabic</b> .....	62
<b>Japanese</b> .....	64

---

---

## **CHAPTER 1: INTRODUCTION**

### **1.1 BEFORE YOU START**

Thank you for choosing our product. Before you start installing the motherboard, please make sure you follow the instructions below:

- Prepare a dry and stable working environment with sufficient lighting.
- Always disconnect the computer from power outlet before operation.
- Before you take the motherboard out from anti-static bag, ground yourself properly by touching any safely grounded appliance, or use grounded wrist strap to remove the static charge.
- Avoid touching the components on motherboard or the rear side of the board unless necessary. Hold the board on the edge, do not try to bend or flex the board.
- Do not leave any unfastened small parts inside the case after installation. Loose parts will cause short circuits which may damage the equipment.
- Keep the computer from dangerous area, such as heat source, humid air and water.

### **1.2 PACKAGE CHECKLIST**

- ⊕ HDD Cable X 1
- ⊕ Serial ATA Cable X 1
- ⊕ Rear I/O Panel for ATX Case X 1
- ⊕ User's Manual X 1
- ⊕ Fully Setup Driver CD X 1
- ⊕ FDD Cable X 1 (optional)
- ⊕ USB 2.0 Cable X1 (optional)
- ⊕ S/PDIF out Cable X 1 (optional)

### 1.3 MOTHERBOARD FEATURES

SPEC		
CPU	Socket AM2 AMD Athlon 64 / Athlon 64 FX / Athlon 64 x2 / Sempron processors	AMD 64 Architecture enables 32 and 64 bit computing Supports Hyper Transport and Cool'nQuiet
FSB	Supports up to 1 GHz Bandwidth	Support HyperTransport
Chipset	AMD 690G AMD SB600	
Super I/O	ITE 8716F Provides the most commonly used legacy Super I/O functionality. Low Pin Count Interface	Environment Control initiatives, H/W Monitor Fan Speed Controller ITE's "Smart Guardian" function
Main Memory	DDR2 DIMM Slots x 4 Max Memory Capacity 4GB	Each DIMM supports 256/512MB & 1GB DDR2 Dual Channel Mode DDR2 memory module Supports DDR2 400/ 533 / 667 / 800 Registered DIMM and ECC DIMM is not supported
Graphics	Integrated in AMD 690G Chipset	Max Shared Video Memory is 512MB
IDE	Integrated IDE Controller	Ultra DMA 33 / 66 / 100 / 133 Bus Master Mode supports PIO Mode 0~4,
SATA II	Integrated Serial ATA Controller Data transfer rates up to 3 Gb/s.	SATA Version 2.0 specification compliant.
LAN	Realtek 8111B(PCI-E)	10 / 100 Mb/s and 1Gb/s Auto-Negotiation Half / Full duplex capability
Sound	ALC888 / Integrated in AMD 690G (for HDMI Audio)	7.1 channels audio out (ALC888) 2 channels audio out (for HDMI Audio) High Definition Audio
Slots	PCI slot	x2 Supports PCI expansion cards
	PCI Express x16 slot	x1 Supports PCI express x16 expansion cards
	PCI Express x 1 slot	x1 Supports PCI express x1 expansion cards
On Board Connector	Floppy connector	x1 Each connector supports 2 Floppy drives
	Printer Port connector	x1 Each connector supports 1 Printer port

SPEC			
	IDE Connector	x1	Each connector supports 2 IDE device
	SATA Connector	x4	Each connector supports 1 SATA devices
	Front Panel Connector	x1	Support front panel facilities
	Front Audio Connector	x1	Support front panel audio function
	CD-in Connector	x1	Support CD audio-in function
	S/PDIF out connector	x1	Support digital audio out function
	S/PDIF in connector (Optional)	x1	Support digital audio in function
	CPU Fan header	x1	CPU Fan power supply (with Smart Fan function)
	System Fan header	x3	System Fan Power supply
	CMOS clear header	x1	Restore CMOS data to factory default
	USB connector	x3	Each connector supports 2 front panel USB ports
	Serial port Connector	x1	Connect to RS-232 Port
	Power Connector (24pin)	x1	Connect to Power supply
	Power Connector (4pin)	x1	Connect to Power supply
Back Panel I/O	PS/2 Keyboard	x1	Connect to PS/2 Keyboard
	PS/2 Mouse	x1	Connect to PS/2 Mouse
	S-Video port	x1	Connect to TV
	HDMI port	x1	Connect to HDTV
	VGA port	x1	Connect to D-SUB monitor
	DVI-D port	x1	Connect to DVI monitor
	LAN port	x1	Connect to RJ-45 ethernet cable
	USB Port	x4	Connect to USB devices
	Audio Jack	x6	Provide Audio-In/Out and microphone connection
Board Size	244 mm(W) x 244 mm(L)		Micro ATX Size Board
Special Features	RAID 0 / 1 / 1+0 support		
OS Support	Windows XP / VISTA		Biostar Reserves the right to add or remove support for any OS With or without notice.

## 1.4 REAR PANEL CONNECTORS

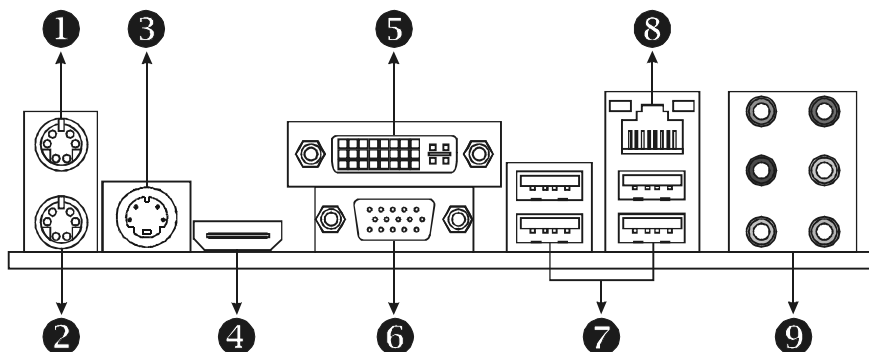

**1 PS/2 Mouse Port**

**2 PS/2 Keyboard Port**

**3 S-Video TV-Out Port**

Transmit analog video signals to TV or any other display panels equipped with S-Video input.

**4 HDMI Port**

The High-Definition Multimedia Interface (HDMI) is an all-digital audio/video interface capable of transmitting uncompressed streams to an AV receiver or any compatible digital audio and/or video monitor, such as a digital television.

**5 DVI-D VGA Port**

The Digital Visual Interface (DVI) is a video interface transmitting digital video signals to digital display devices such as flat panel LCDs or digital projectors. The DVI-D connector allows digital signals transmission only.

**6 D-Sub VGA Port**

Transmit analog video signals to computer monitor or any other display panels equipped with D-Sub VGA input.

**7 USB 2.0 Port x 4**

**8 10/100/1000 Mbps LAN Port**

**9 Audio Jack x 6**

Port	2-Channel	4-Channel	6-Channel/8-Channel
<b>Blue</b>	Line-In	Line-In	Line-In
<b>Green</b>	Line-Out	Front Speaker Out	Front Speaker Out
<b>Pink</b>	Mic In	Mic In	Mic In
<b>Orange</b>			Center/Subwoofer
<b>Black</b>	Rear Speaker Out	Rear Speaker Out	Rear Speaker Out
<b>Grey</b>			Side Speaker Out

**NOTE 1:** The HDMI and DVI-D ports both can provide digital video signals out-put function, but these two interfaces cannot work at the same time. The AMD 690G chipset uses the same channel to control HDMI and DVI-D, so these ports cannot transmit video signal to different display panels simultaneously.

**NOTE 2:** The AMD 690G chipset uses the same channel to control S-Video and D-Sub for transmitting analog video signals, so these ports cannot work simultaneously either.

### 1.5 MOTHERBOARD LAYOUT

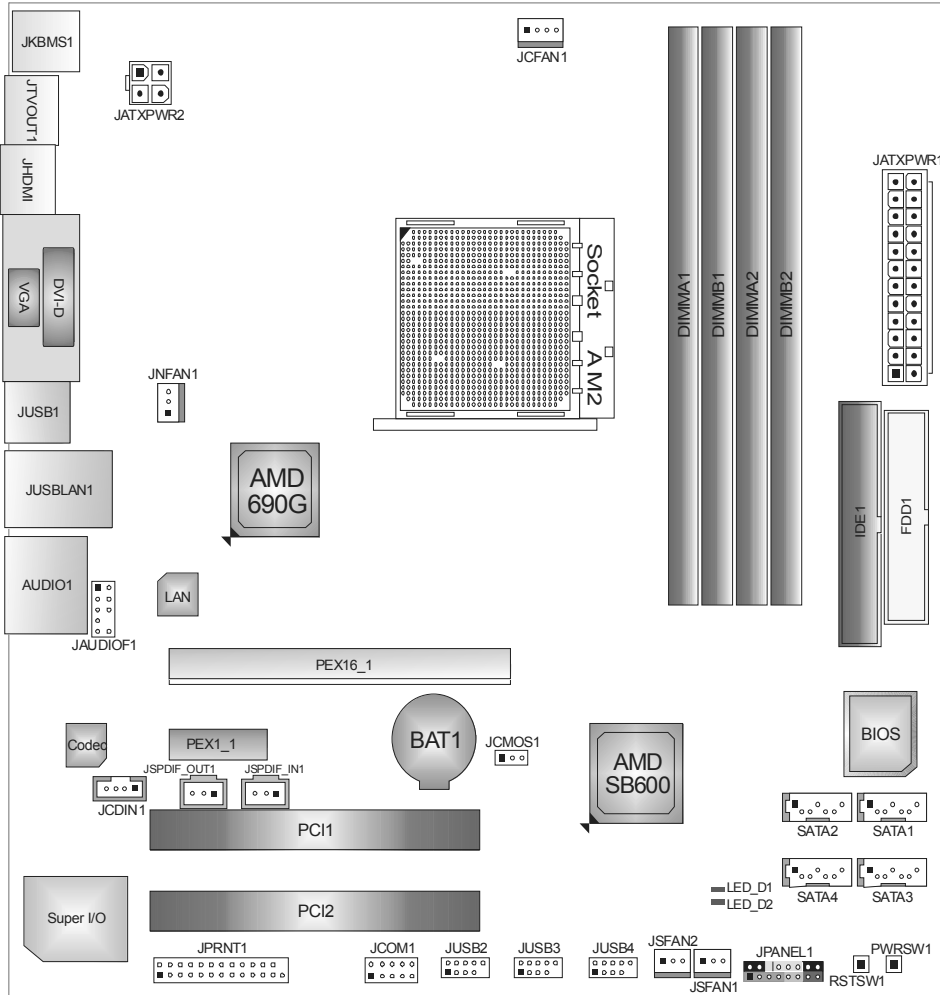

**Note:** ■ represents the 1<sup>st</sup> pin.

## CHAPTER 2: HARDWARE INSTALLATION

### 2.1 INSTALLING CENTRAL PROCESSING UNIT (CPU)

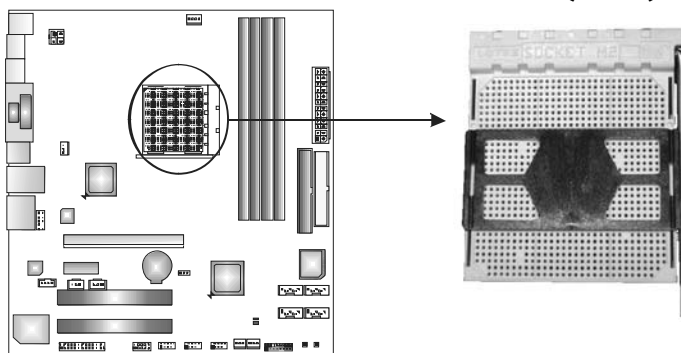

**Step 1:** Remove the socket protection cap.

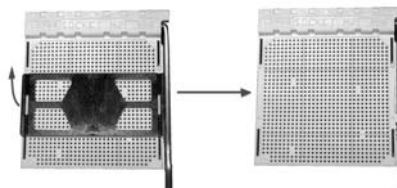

**Step 2:** Pull the lever toward direction A from the socket and then raise the lever up to a 90-degree angle.

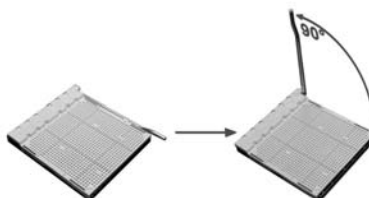

**Step 3:** Look for the white triangle on socket, and the gold triangle on CPU should point towards this white triangle. The CPU will fit only in the correct orientation.





**Step 4:** Hold the CPU down firmly, and then close the lever toward direct B to complete the installation.

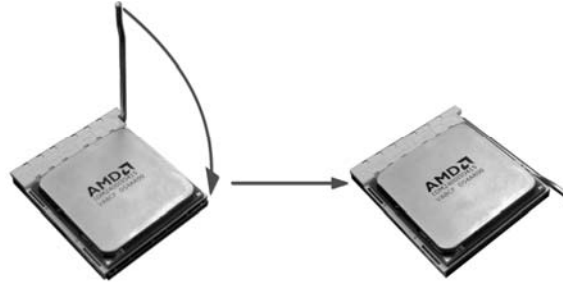

**Step 5:** Put the CPU Fan on the CPU and buckle it. Connect the CPU FAN power cable to the JCFAN1. This completes the installation.

## 2.2 FAN HEADERS

These fan headers support cooling-fans built in the computer. The fan cable and connector may be different according to the fan manufacturer. Connect the fan cable to the connector while matching the black wire to pin#1.

### JCFAN1: CPU Fan Header

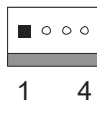
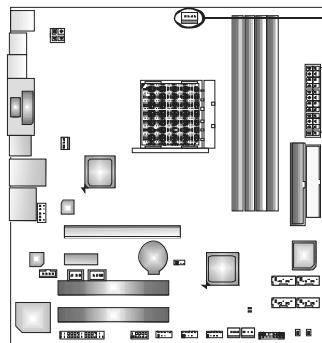

Pin	Assignment
1	Ground
2	+12V
3	FAN RPM rate sense
4	Smart Fan Control (By Fan)

### JNFAN1: North Bridge Fan Header

### JSFAN1/JSFAN2: System Fan Header

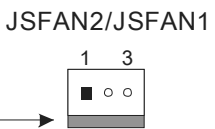
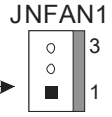
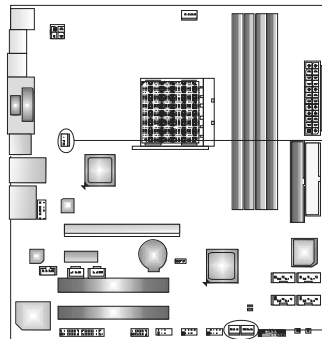

Pin	Assignment
1	Ground
2	+12V
3	FAN RPM rate sense

**Note:**

The JCFAN1 supports 4-pin head connector. The JSFAN1/JSFAN2 and JNFAN1 support 3-pin head connectors. When connecting with wires onto connectors, please note that the red wire is the positive and should be connected to pin#2, and the black wire is Ground and should be connected to GND.

## 2.3 INSTALLING SYSTEM MEMORY

### A. Memory Modules

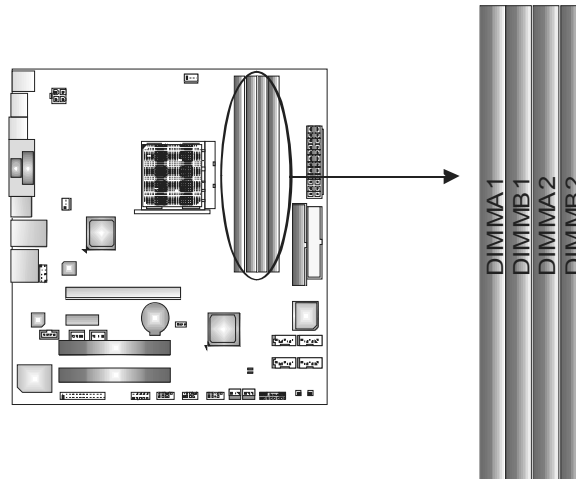

1. Unlock a DIMM slot by pressing the retaining clips outward. Align a DIMM on the slot such that the notch on the DIMM matches the break on the Slot.

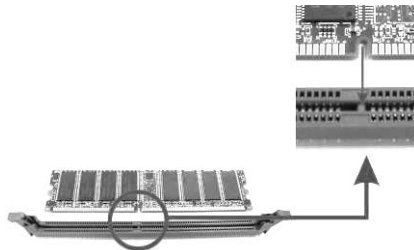

2. Insert the DIMM vertically and firmly into the slot until the retaining chip snap back in place and the DIMM is properly seated.

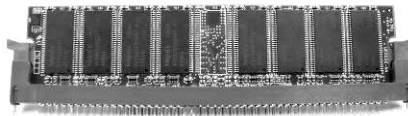

**B. Memory Capacity**

DIMM Socket Location	DDR2 Module	Total Memory Size
DIMMA1	256MB/512MB/1024MB	Max is 4GB.
DIMMB1	256MB/512MB/1024MB	
DIMMA2	256MB/512MB/1024MB	
DIMMB2	256MB/512MB/1024MB	

**C. Dual Channel Memory installation**

To trigger the Dual Channel function of the motherboard, the memory module must meet the following requirements:

Install memory module of the same density in pairs, shown in the following table.

Dual Channel Status	DIMMA1	DIMMB1	DIMMA2	DIMMB2
Enabled	O	O	X	X
Enabled	X	X	O	O
Enabled	O	O	O	O

(O means memory installed, X means memory not installed.)

The DRAM bus width of the memory module must be the same (x8 or x16)

## 2.4 CONNECTORS AND SLOTS

### FDD1: Floppy Disk Connector

The motherboard provides a standard floppy disk connector that supports 360K, 720K, 1.2M, 1.44M and 2.88M floppy disk types. This connector supports the provided floppy drive ribbon cables.

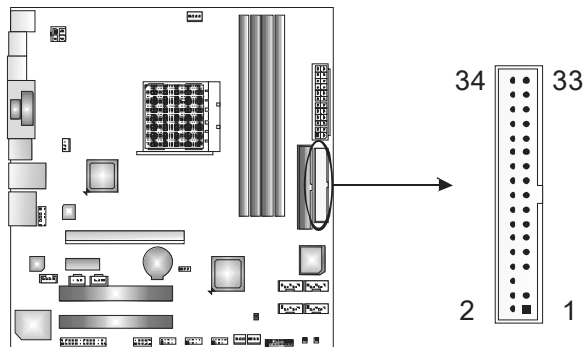

### IDE1: Hard Disk Connector

The motherboard has a 32-bit Enhanced PCI IDE Controller that provides PIO Mode 0~4, Bus Master, and Ultra DMA 33/66/100/133 functionality.

The IDE connector can connect a master and a slave drive, so you can connect up to two hard disk drives.

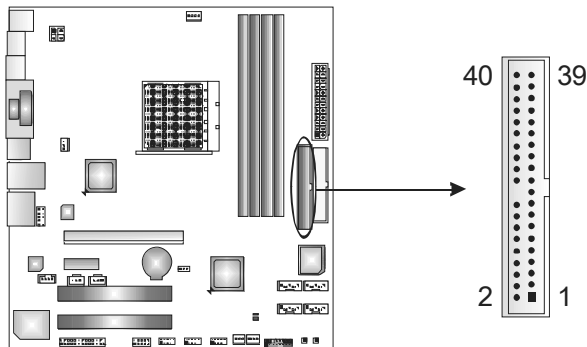

**PEX16\_1: PCI-Express x16 Slot**

- PCI-Express 1.0a compliant.
- Maximum theoretical realized bandwidth of 4GB/s simultaneously per direction, for an aggregate of 8GB/s totally.

**PEX1\_1: PCI-Express x1 slots**

- PCI-Express 1.0a compliant.
- Data transfer bandwidth up to 250MB/s per direction; 500MB/s in total.
- PCI-Express supports a raw bit-rate of 2.5GB/s on the data pins.
- 2X bandwidth over the traditional PCI architecture.

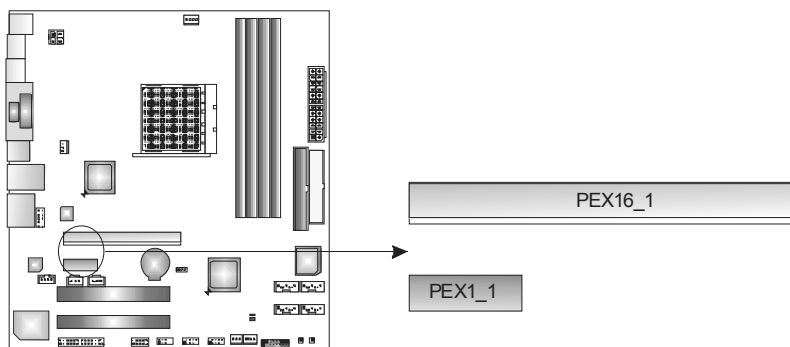

**PCI1~PCI2: Peripheral Component Interconnect Slots**

This motherboard is equipped with 2 standard PCI slots. PCI stands for Peripheral Component Interconnect, and it is a bus standard for expansion cards. This PCI slot is designated as 32 bits.

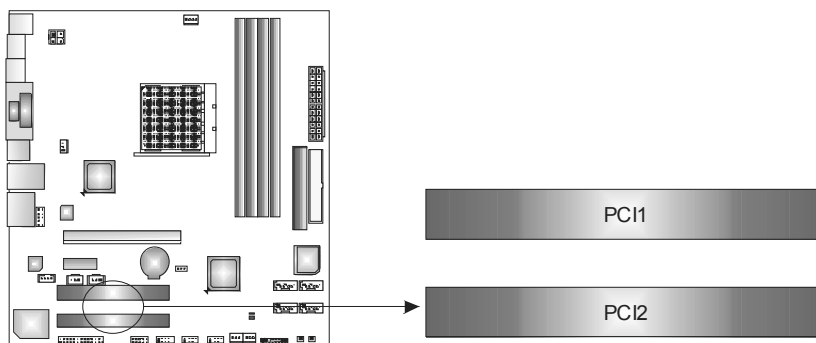

## CHAPTER 3: HEADERS & JUMPERS SETUP

### 3.1 HOW TO SETUP JUMPERS

The illustration shows how to set up jumpers. When the jumper cap is placed on pins, the jumper is “close”, if not, that means the jumper is “open”.

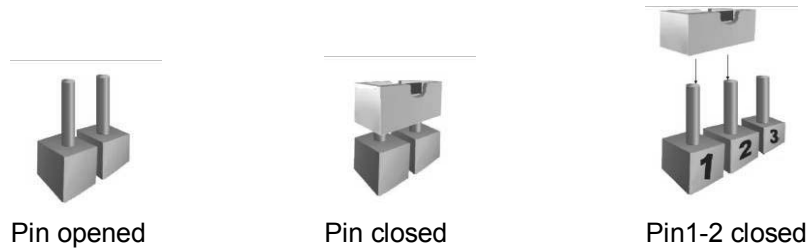

### 3.2 DETAIL SETTINGS

#### JPANEL1: Front Panel Header

This 16-pin connector includes Power-on, Reset, HDD LED, Power LED, Sleep button and speaker connection. It allows user to connect the PC case’s front panel switch functions.

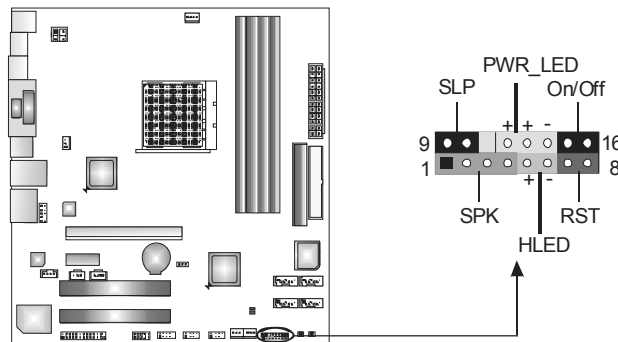

Pin	Assignment	Function	Pin	Assignment	Function
1	+5V		9	Sleep control	Sleep button
2	N/A	Speaker Connector	10	Ground	
3	N/A		11	N/A	N/A
4	Speaker		12	Power LED (+)	Power LED
5	HDD LED (+)	Hard drive LED	13	Power LED (+)	
6	HDD LED (-)		14	Power LED (-)	
7	Ground	Reset button	15	Power button	Power-on button
8	Reset control		16	Ground	

**JATXPWR1: ATX Power Source Connector**

This connector allows user to connect 24-pin power connector on the ATX power supply.

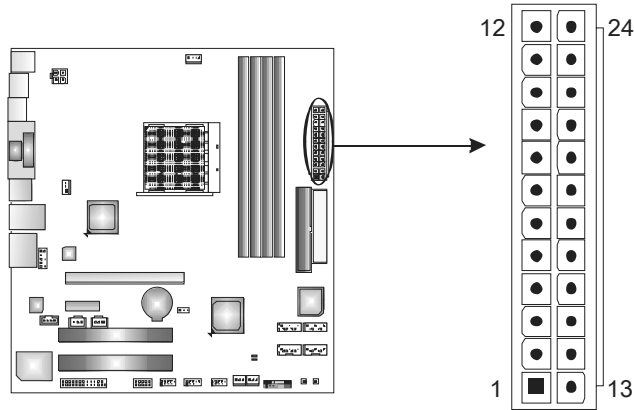

Pin	Assignment	Pin	Assignment
13	+3.3V	1	+3.3V
14	-12V	2	+3.3V
15	Ground	3	Ground
16	PS_ON	4	+5V
17	Ground	5	Ground
18	Ground	6	+5V
19	Ground	7	Ground
20	NC	8	PW_OK
21	+5V	9	Standby Voltage+5V
22	+5V	10	+12V
23	+5V	11	+12V
24	Ground	12	+3.3V

**JATXPWR2: ATX Power Source Connector**

By connecting this connector, it will provide +12V to CPU power circuit.

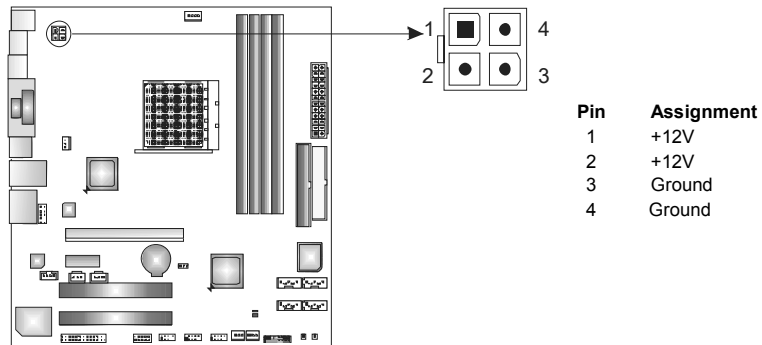



**JUSB2/JUSB3/JUSB4: Headers for USB 2.0 Ports at Front Panel**

This header allows user to connect additional USB cable on the PC front panel, and also can be connected with internal USB devices, like USB card reader.

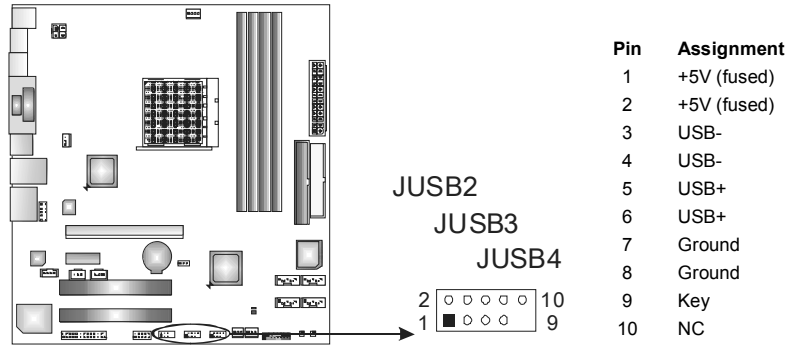

**JAUDIOF1: Front Panel Audio Header**

This header allows user to connect the front audio output cable with the PC front panel. It will disable the output on back panel audio connectors.

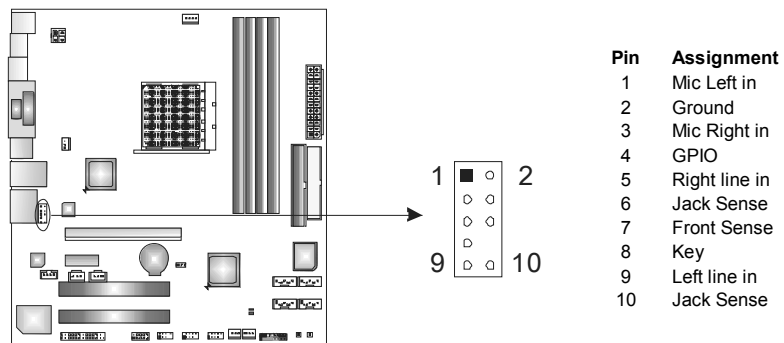

**JCDIN1: CD-ROM Audio-in Connector**

This connector allows user to connect the audio source from the variety devices, like CD-ROM, DVD-ROM, PCI sound card, PCI TV turner card etc..

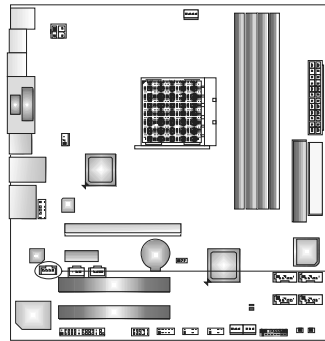

Pin	Assignment
1	Left Channel Input
2	Ground
3	Ground
4	Right Channel Input

**JCMOS1: Clear CMOS Header**

By placing the jumper on pin2-3, it allows user to restore the BIOS safe setting and the CMOS data, please carefully follow the procedures to avoid damaging the motherboard.

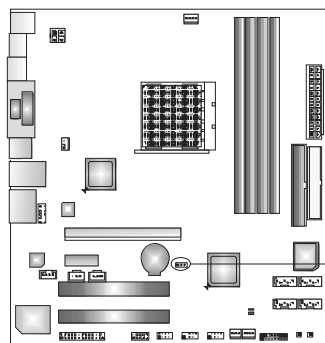

**Pin 1-2 Close:**  
Normal Operation (default).



**Pin 2-3 Close:**  
Clear CMOS data.

**※ Clear CMOS Procedures:**

1. Remove AC power line.
2. Set the jumper to "Pin 2-3 close".
3. Wait for five seconds.
4. Set the jumper to "Pin 1-2 close".
5. Power on the AC.
6. Reset your desired password or clear the CMOS data.

### SATA1~SATA4: Serial ATA Connectors

The motherboard has a PCI to SATA Controller with 4 channels SATA interface.

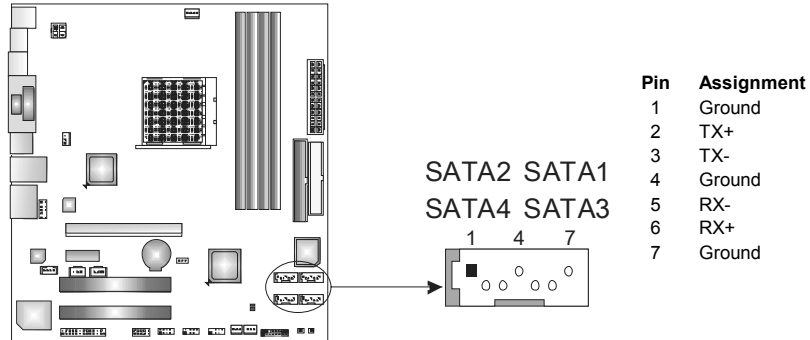

### JPRNT1: Printer Port Connector

This header allows you to connector printer on the PC.

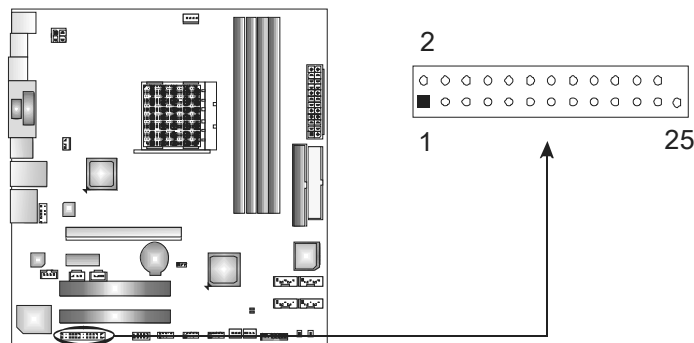

Pin	Assignment	Pin	Assignment
1	-Strobe	14	Ground
2	-ALF	15	Data 6
3	Data 0	16	Ground
4	-Error	17	Data 7
5	Data 1	18	Ground
6	-Init	19	-ACK
7	Data 2	20	Ground
8	-Scltin	21	Busy
9	Data 3	22	Ground
10	Ground	23	PE
11	Data 4	24	Ground
12	Ground	25	SCLT
13	Data 5	26	Key

**JSPDIF\_OUT1: Digital Audio-out Connector**

This connector allows user to connect the PCI bracket SPDIF output header.

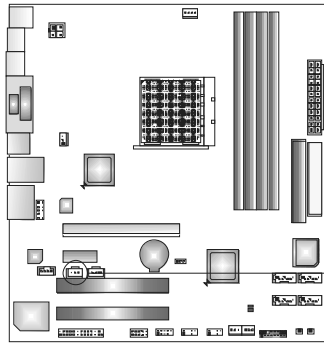

Pin	Assignment
1	+5V
2	SPDIF_OUT
3	Ground

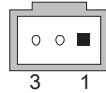

**JSPDIF\_IN1: Digital Audio-out Connector (Optional)**

This connector allows user to connect the PCI bracket SPDIF input header.

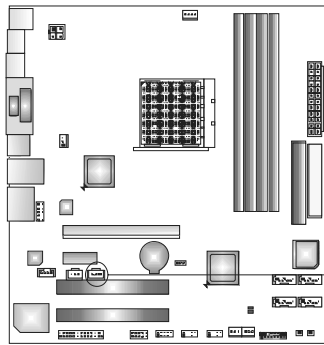

Pin	Assignment
1	+5V
2	SPDIF_IN
3	Ground

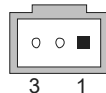

**JCOM1: Serial port Connector**

The motherboard has a Serial Port Connector for connecting RS-232 Port.

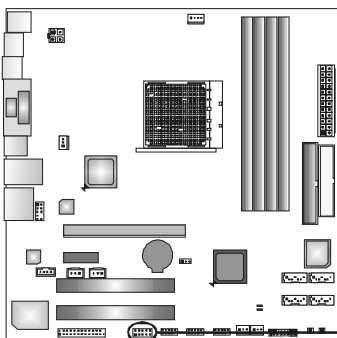

Pin	Assignment
1	Carrier detect
2	Received data
3	Transmitted data
4	Data terminal ready
5	Signal ground
6	Data set ready
7	Request to send
8	Clear to send
9	Ring indicator
10	Key

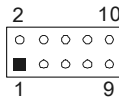

### On-Board Buttons

There are 2 on-board buttons.

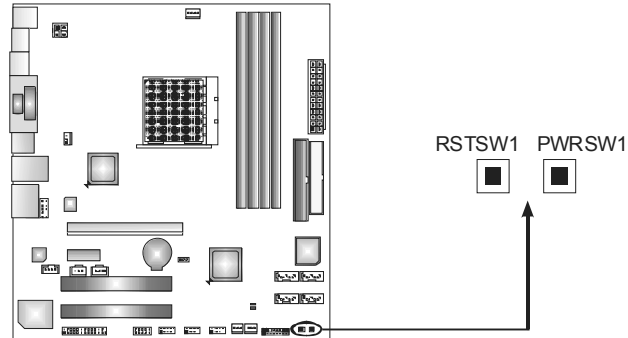

**PWRSW1:**

This is an on-board Power Switch button.

**RSTW1:**

This is an on-board Reset button.

### On-Board LED Indicators

There are 2 LED indicators on the motherboard to show system status.

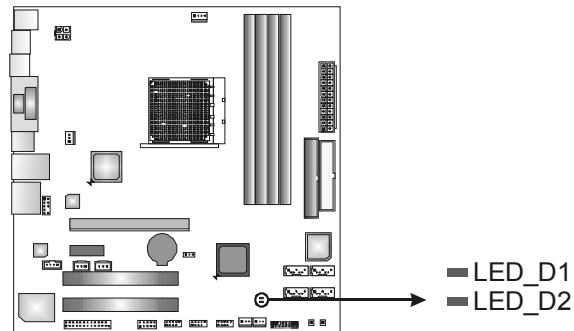

**LED\_D1 and LED\_D2:**

These 2 LED indicate system power on diagnostics.

Please refer to the table below for different messages:

LED_D1	LED_D2	Message
ON	ON	Normal
ON	OFF	Memory Error
OFF	ON	VGA Error
OFF	OFF	Abnormal: CPU / Chipset error.

---

---

## CHAPTER 4: RAID FUNCTIONS

### 4.1 OPERATION SYSTEM

- Supports Windows XP Home/Professional Edition, and Windows Vista.

### 4.2 RAID ARRAYS

RAID supports the following types of RAID arrays:

**RAID 0:** RAID 0 defines a disk striping scheme that improves disk read and write times for many applications.

**RAID 1:** RAID 1 defines techniques for mirroring data.

**RAID 1+0:** RAID 1+0 combines the techniques used in RAID 0 and RAID 1.

### 4.3 How RAID WORKS

#### RAID 0:

The controller “stripes” data across multiple drives in a RAID 0 array system. It breaks up a large file into smaller blocks and performs disk reads and writes across multiple drives in parallel. The size of each block is determined by the stripe size parameter, which you set during the creation of the RAID set based on the system environment. This technique reduces overall disk access time and offers high bandwidth.

#### Features and Benefits

- **Drives:** Minimum 1, and maximum is up to 6 or 8. Depending on the platform.
- **Uses:** Intended for non-critical data requiring high data throughput, or any environment that does not require fault tolerance.
- **Benefits:** provides increased data throughput, especially for large files. No capacity loss penalty for parity.
- **Drawbacks:** Does not deliver any fault tolerance. If any drive in the array fails, all data is lost.
- **Fault Tolerance:** No.

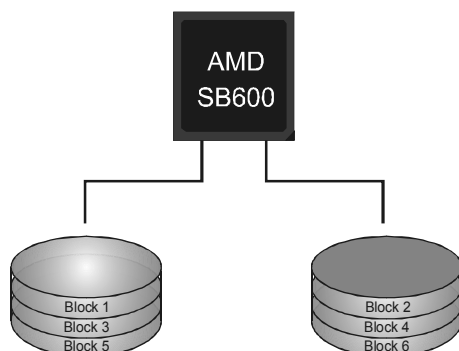

**RAID 1:**

Every read and write is actually carried out in parallel across 2 disk drives in a RAID 1 array system. The mirrored (backup) copy of the data can reside on the same disk or on a second redundant drive in the array. RAID 1 provides a hot-standby copy of data if the active volume or drive is corrupted or becomes unavailable because of a hardware failure.

RAID techniques can be applied for high-availability solutions, or as a form of automatic backup that eliminates tedious manual backups to more expensive and less reliable media.

**Features and Benefits**

- **Drives:** Minimum 2, and maximum is 2.
- **Uses:** RAID 1 is ideal for small databases or any other application that requires fault tolerance and minimal capacity.
- **Benefits:** Provides 100% data redundancy. Should one drive fail, the controller switches to the other drive.
- **Drawbacks:** Requires 2 drives for the storage space of one drive. Performance is impaired during drive rebuilds.
- **Fault Tolerance:** Yes.

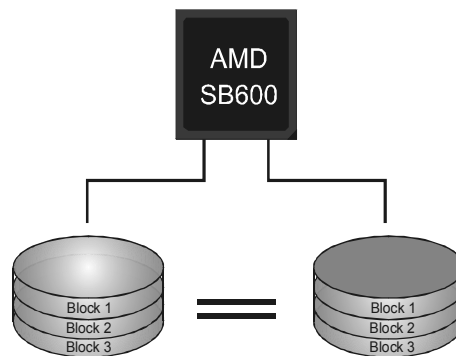

**RAID 1+0:**

RAID 1 drives can be striped using RAID 0 techniques. Resulting in a RAID 1+0 solution for improved resiliency, performance and rebuild performance.

**Features and Benefits**

- **Drives:** Minimum 4, and maximum is 6 or 8, depending on the platform.
- **Benefits:** Optimizes for both fault tolerance and performance, allowing for automatic redundancy. May be simultaneously used with other RAID levels in an array, and allows for spare disks.
- **Drawbacks:** Requires twice the available disk space for data redundancy, the same as RAID level 1.
- **Fault Tolerance:** Yes.

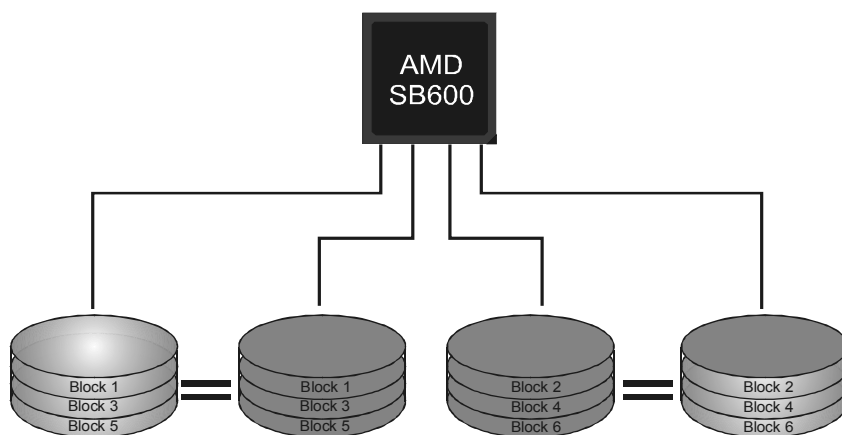



---

---

## CHAPTER 5: OVERCLOCK QUICK GUIDE

### 5.1 T-POWER INTRODUCTION

*Biostar T-Power* is a whole new utility that is designed for overclock users. Based on many precise tests, *Biostar Engineering Team* (BET) has developed this ultimate overclock engine to raise system performance. No matter whether under BIOS or Windows interface, *T-Power* is able to present the best system state according to users' overclock setting.

#### **T-Power BIOS Features:**

- Overclocking Navigator Engine (O.N.E.)
- CMOS Reloading Program (C.R.P.)
- Memory Integration Test (M.I.T., under Overclock Navigator Engine)
- Integrated Flash Program (I.F.P.)
- Smart Fan Function (under PC Health Status)
- Self Recovery System (S.R.S)

#### **T-Power Windows Feature:**

- Hardware Monitor
- Overclock Engine
- Smart Fan Function
- Life Update

## 5.2 T-POWER BIOS FEATURE

### A. Overclocking Navigator Engine (O.N.E.):

ONE provides two powerful overclocking engines: MOS and AOS for both Elite and Casual overclockers.

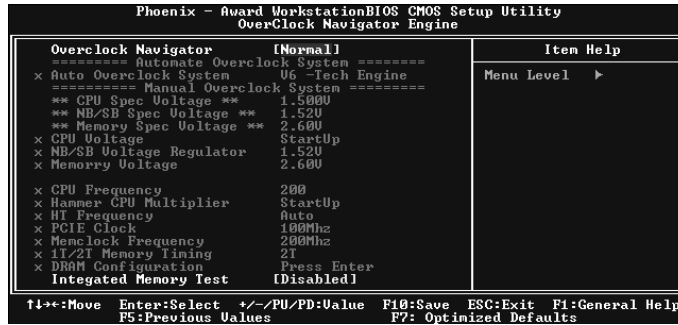

### Manual Overclock System (M.O.S.)

MOS is designed for experienced overclock users.

It allows users to customize personal overclock settings.

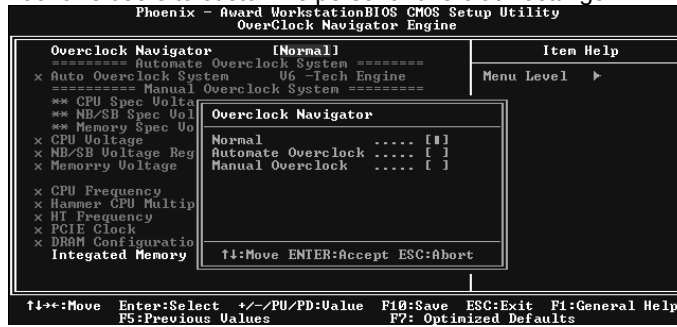

**CPU Overclock Setting:**

**CPU Voltage:**

This function will increase CPU stability when overclocking. However, the CPU temperature will increase when CPU voltage is increased.

**Choices:** The range is from 1.2V to 1.725V, with an interval of 0.0.25V.

**CPU Frequency:**

CPU Frequency is directly in proportion to system performance. To maintain the system stability, CPU voltage needs to be increased also when raising CPU frequency.

**Choices:** This range is from 200 to 450, with an interval of 1MHz.

**Hammer CPU Multiplier:**

The MOS allows users to downgrade the CPU ratio when overclocking.

**Choices:** The lower limit is x4 (800MHz). The upper limit is decided by different CPU type. With an x1 (200MHz) interval.

**Memory Overclock Setting:**

**Memory Voltage:**

This function will increase memory stability when overclocking.

**Choices:** The range is from 1.85V to 2.0V, with an interval of 0.05V.

**Memclock Frequency:**

To get better system performance, sometimes downgrading the memory frequency is necessary when CPU frequency is adjusted over the upper limit.

**Choices:** DDR2 400, DDR2 533, DDR2 667, DDR2 800 (MHz).

**PCI-Express Overclock Setting:**

**PCIE Clock:**

It helps to increase VGA card performance.

**Choices:** The range is from 100 to 145, with an interval of 1MHz.

**Chipset Overclock Setting:**

**NB/SB Voltage Regulator:**

This function will increase chipset stability when overclocking.

**Choices:** 1.52V, 1.60V, 1.68V, 1.76V.

**HT Frequency:**

We recommend users to set this item at "x4" when overclocking.

**Choices:** x1, x2, x3, x4, x5, Auto.

### Automatic Overclock System (A.O.S.)

For beginners in overclock field, BET had developed an easy, fast, and powerful feature to increase the system performance, named A.O.S. Based on many tests and experiments, A.O.S. provides 3 ideal overclock configurations that are able to raise the system performance in a single step.

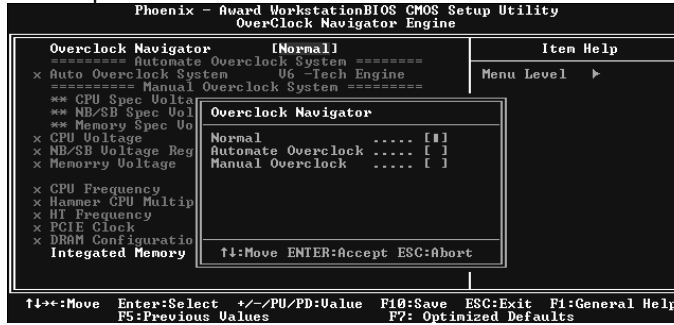

#### V6 Tech Engine:

This setting will raise about 10%~15% of whole system performance.

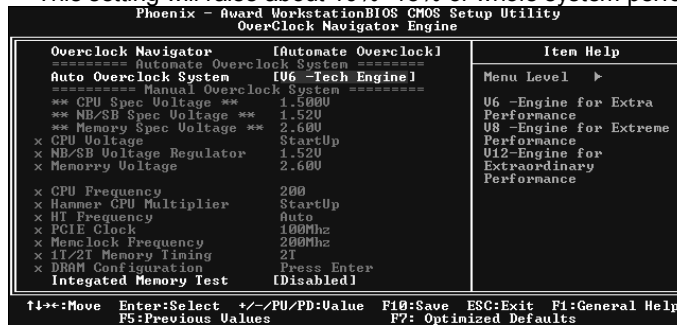

#### V8 Tech Engine:

This setting will raise about 15%~25% of whole system performance.



**V12 Tech Engine:**

This setting will raise about 25%~30% of whole system performance.

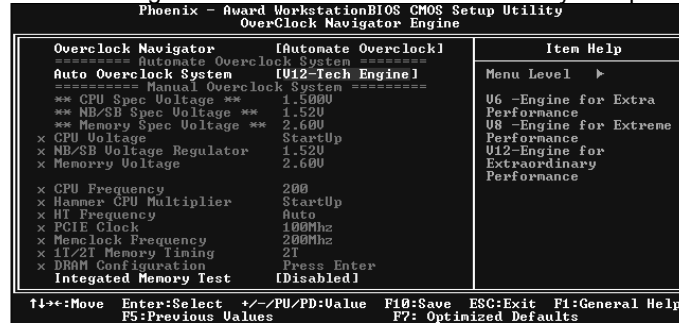
**Notices:**

1. Not all types of AMD CPU perform above overclock setting ideally; the difference will be based on the selected CPU model.
2. From BET experiments, the Atholon64 FX CPU is not suitable for this A.O.S. feature.

**B. CMOS Reloading Program (C.R.P.):**

It allows users to save different CMOS settings into BIOS-ROM.

Users are able to reload any saved CMOS setting for customizing system configurations.

Moreover, users are able to save an ideal overclock setting during overclock operation.

There are 50 sets of record addresses in total, and users are able to name the CMOS data according to personal preference.

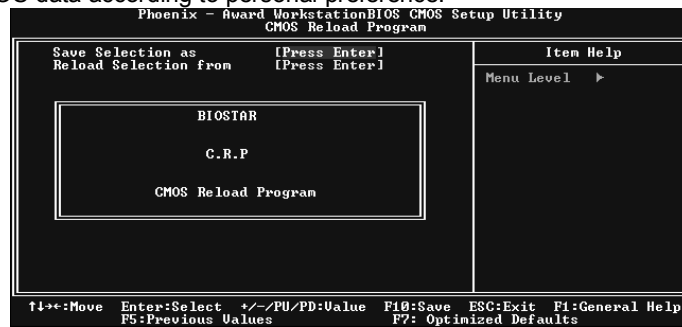

**C. Memory Integration Test (M.I.T.):**

This function is under “Overclocking Navigator Engine” item. MIT allows users to test memory compatibilities, and no extra devices or software are needed.

**Step 1:**

The default setting under this item is “Disabled”; the condition parameter should be changed to “Enable” to proceed this test.

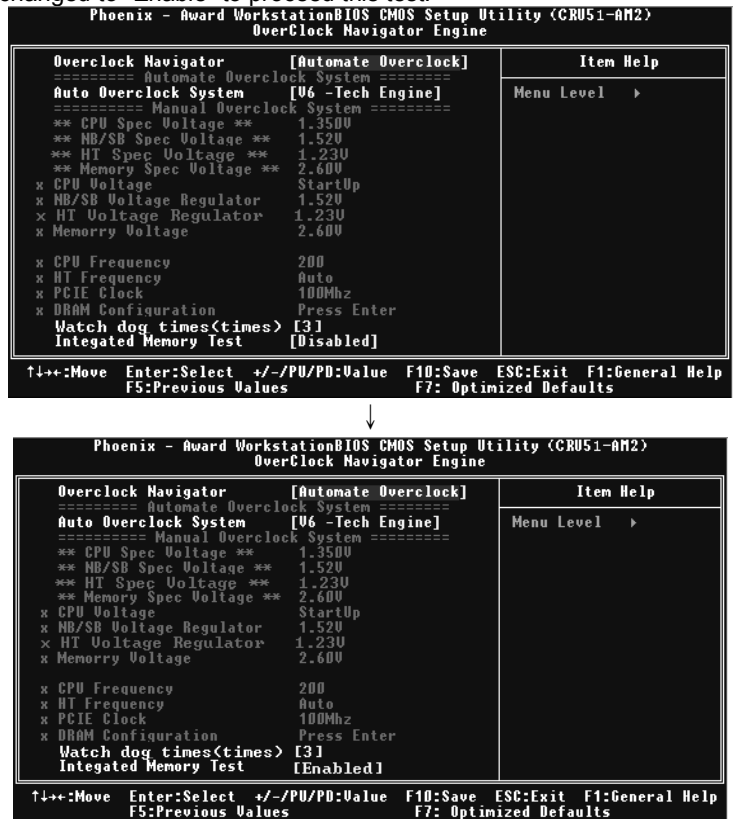

**Step 2:**

Save and Exit from CMOS setup and reboot the system to activate this test. Run this test for 5 minutes (minimum) to ensure the memory stability.

**Step 3:**

When the process is done, change the setting back from “Enable” to “Disable” to complete the test.

**D. Self Recovery System (S.R.S.):**

This function can't be seen under T-Power BIOS setup; and is always on whenever the system starts up.

However, it can prevent system hang-up due to inappropriate overclock actions.

When the system hangs up, S.R.S. will automatically log in the default BIOS setting, and all overclock settings will be re-configured.

**E. Integrated Flash Program (I.F.P.):**

IFP is a safe and quick way to upgrade BIOS.

**Step 1:**

Go to Biostar website (<http://www.biostar.com.tw>) to download the latest BIOS file. Then, save the file into a floppy disk.

**Step 2:**

Insert the floppy disk and reboot the system to get into CMOS screen.

**Step 3:**

Select the item "Integrated Flash Program" to get the following frame and choose the BIOS file downloaded in step 1.

**Step 4:**

Press "Enter" key to start BIOS file loading, and BIOS updating will process automatically.

**Step 5:**

When the BIOS update is completed, press YES to the message "Flash done, Reset system", and the system will reboot automatically to finish the process.

**Advise:**

You can update the system BIOS by simply pressing "Enter" key for three times.

### F. Smart Fan Function:

Smart Fan Function is under “PC Health Status”.

This is a brilliant feature to control CPU Temperature vs. Fan speed.

When enabling Smart Fan function, Fan speed is controlled automatically by CPU temperature.

This function will protect CPU from overheat problem and maintain the system temperature at a safe level.

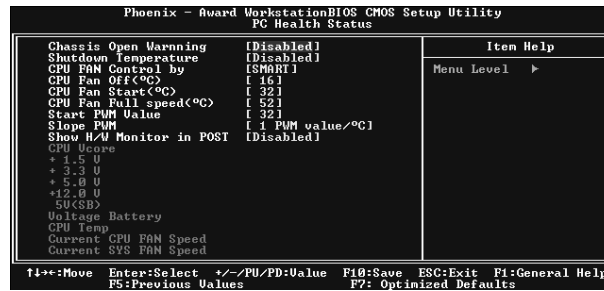
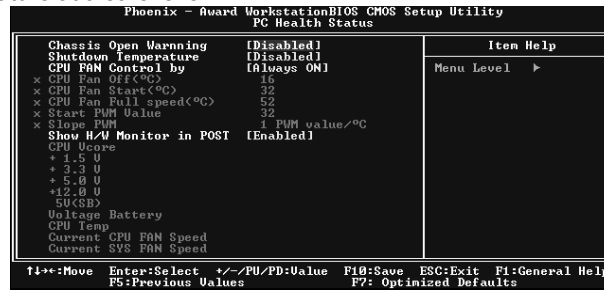

#### CPU Fan Off (<math>^{\circ}\text{C}</math>):

If the CPU temperature is lower than the set value, the CPU fan will turn off. The range is from 0<math>^{\circ}\text{C}</math>~127<math>^{\circ}\text{C}</math>, with an interval of 1<math>^{\circ}\text{C}</math>.

#### CPU Fan Start (<math>^{\circ}\text{C}</math>)

The CPU fan starts to work when CPU temperature arrives to this set value. The range is from 0<math>^{\circ}\text{C}</math>~127<math>^{\circ}\text{C}</math>, with an interval of 1<math>^{\circ}\text{C}</math>.

#### CPU Fan Full speed (<math>^{\circ}\text{C}</math>)

When CPU temperature arrives to the set value, the CPU fan will work under Full Speed. The range is from 0<math>^{\circ}\text{C}</math>~127<math>^{\circ}\text{C}</math>, with an interval of 1<math>^{\circ}\text{C}</math>.



### Start PWM Value

When CPU temperature arrives to the set value, the CPU fan will work under Smart Fan Function mode. The range is from 0~127, with an interval of 1.

### Slope PWM

Choices: 1 PWM Value/°C (default), 2 PWM Value/°C, 4 PWM Value/°C, 8 PWM Value/°C, 16 PWM Value/°C, 32 PWM Value/°C, 64 PWM Value/°C.

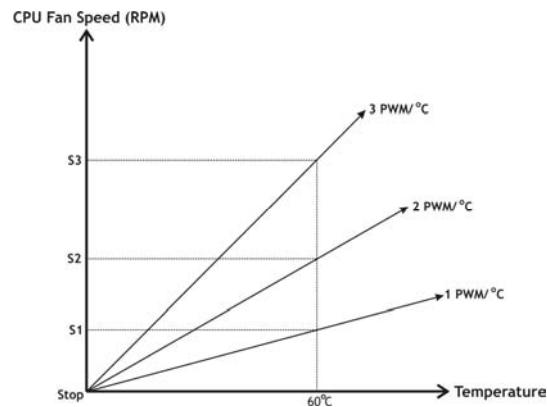

S1: CPU temperature is 60°C, and PWM value is 1 PWM/°C.

S2: CPU temperature is 60°C, and PWM value is 2 PWM/°C.

S3: CPU temperature is 60°C, and PWM value is 3 PWM/°C.

Increasing the value of slope PWM will raise the speed of CPU fan.

As in above diagram, when the CPU temperature reaches 60°C, the CPU fan speed for 3 PWM/°C is higher than 1 PWM/°C ( $S1 < S2 < S3$ ).

### 5.3 T-POWER WINDOWS FEATURE

#### A. Hardware Monitor:

T-Power Hardware monitor allows users to monitor system voltage, temperature and fan speed accordingly. Additionally, a rescue action will be taken by the program automatically while the system faces an abnormal condition. The program will trigger an alarm or shut down the system when unpredictable errors occur. All the monitoring items are illustrated by a waveform diagram.

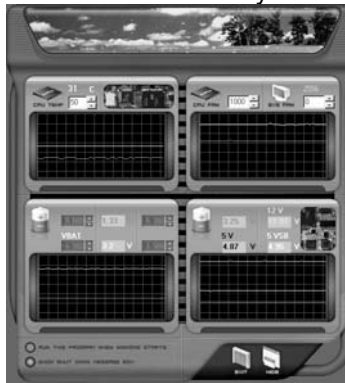

#### Hardware Monitor Toolbar



#### i. Start-up Setting

Click on this item to run Hardware Monitor Program when the Windows starts-up.

#### ii. Dialogue-Box Setting

Click on this item to pop-up warning dialogue-box when PC system is abnormal.

#### iii. Exit

Click on this item to exit Hardware Monitor Program.

#### iv. Hide

Click on this item to hide this program in system tray. When hiding the program, there will be a check icon in the system tray.



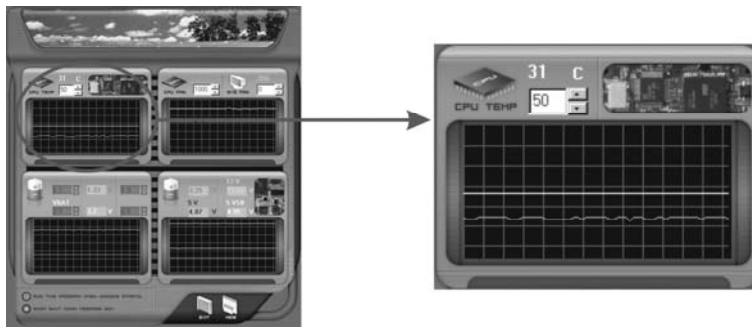

### CPU Temperature

This column configures the CPU temperature. There is a waveform to represent the status of CPU temperature.



By adjusting  , users can easily configure the upper limit of CPU temperature for system operating.

In this diagram, the white line represents the upper limit which user-set for CPU temperature and the green line shows present CPU temperature.

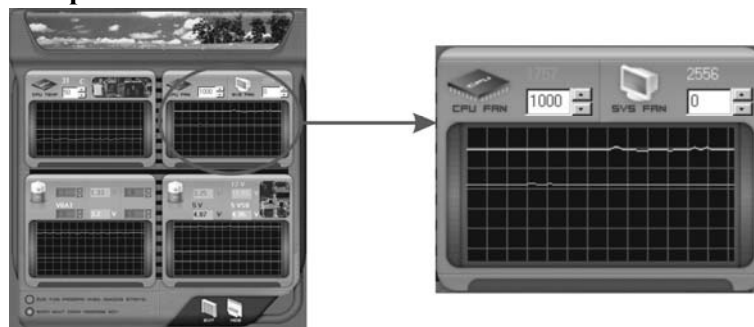

If the CPU temperature is higher than the upper limit, the status line color will change from green to red, and a warning sound will alert you. Also, the system tray icon  would change to .

### FAN Speed



By adjusting  , users can easily configure the lower limit of the fan speed.

In this diagram, the green line shows present CPU Fan speed, and the yellow line shows System Fan speed (if any).

If any one of the fans speeds is lower than the set value, the status line will change into a red warning line, and the program will trigger an alarm system automatically. Also, the system tray icon  would change to .

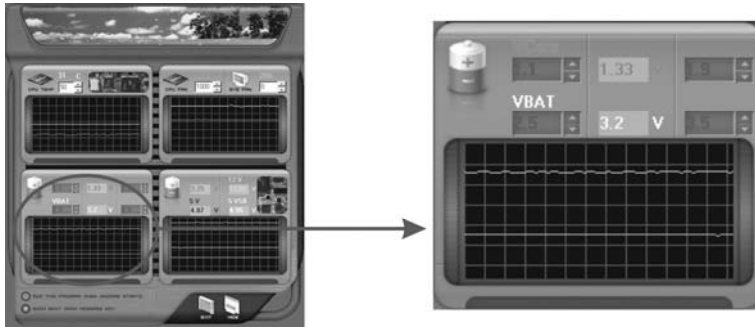

### CPU/Battery Voltage



**i. VCore**

This item displays the CPU voltage, represented by a light blue line.



Users can set the upper and lower limit by adjusting  to monitor the CPU operating voltage.

If CPU voltage is higher or lower than the set value, the status line will change into a red warning line, and a warning sound will alert you. Also, the system tray icon  will change to .

**ii. VBAT**

This item displays the CMOS battery voltage, represented by a light green line.

Users can set the upper and lower limit by adjusting  to monitor the status of battery voltage.

If battery voltage is higher or lower than the set value, the status line will change to a red warning line, and a warning sound will alert you. Also, the system tray icon  will change to .

### Reference data

This column represents the status of power supply voltage and cannot be adjusted, it is only for present status reference.

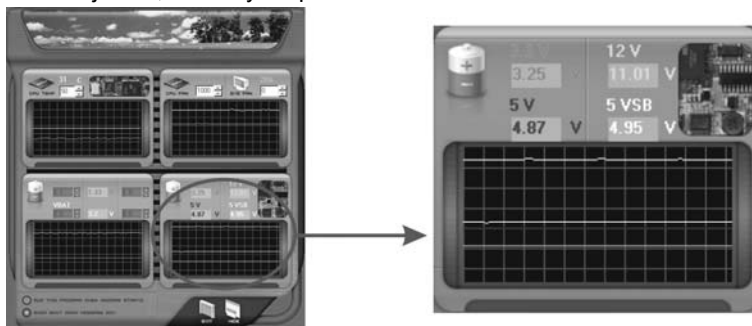

## B. Overclocking Configurations

This diagram is designed for T-series Overclocking utility. Friendly interface and solid overclock features are the major concept of this utility.

Graphic 1 will appear when activating this utility.



Graphic 1

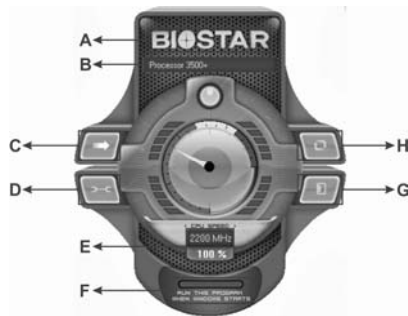

Graphic 2

- A. Clicking on "Biostar" will lead you to the Biostar Homepage.
- B. This column shows the CPU speed information.
- C. Click on this button and the utility will pop-up 4 sub-screens (Please refers to Graphic 3).
- D. Click on this button to minimize this program to taskbar.
- E. This column shows present CPU speed and overlocking percentage.
- F. Clicking on this button will make the program start up as soon as the Windows starts up.
- G. Click on this button to exit this overclock utility.
- H. Click on this button to reset all the overclock features to default setting.

By adjusting the overclocking features in 4 sub-screens, users can tune the system performance to an optimal level.

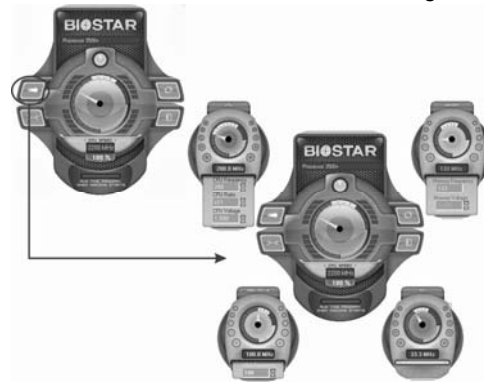

Graphic 3

### CPU Overclocking Settings:



By adjusting  can configure three items for CPU overclocking.

**A. CPU Frequency**

Range: 200MHz~450MHz.

Interval: 1MHz.

**B. CPU Ratio**

Range: 4~25.

Interval: 1.

**C. CPU Voltage**

Range: 0.8V~2.0V.

Interval: 0.0125V.

### Memory Overclocking Settings:



By adjusting  can configure two items for Memory overclocking.

**A. Memory Clock Frequency**

Choices: 100, 133, 200, 266, 333, 400, 533, 667, 800.

**B. Memory Voltage**

Range: 1.8V~2.8V.

Interval: 0.1V.

### AGP/PCI-Express Overclocking Setting:



By adjusting  can configure VGA card overclocking. And this function helps to increase VGA card performance.

Range: 100MHz~150MHz.

Interval: 1MHz.

**PCI Overclocking Setting:**



This diagram shows present PCI working status and helps to monitor PCI peripherals working status.

This item cannot be adjusted.

### C. Smart Fan Function



When Smart Fan Function is activated, screens will pop-up to illustrate the fan speed information.

- i. CPU Temperature:**  
Show current CPU temperature.
- ii. CPU Fan speed:**  
Show current CPU Fan speed.
- iii. System Fan speed:**  
Show current system Fan speed.
- iv. Calibrate:**  
When changing CPU Fan or System Fan, click on this button to re-calibrate the Fan speed.



**Note:**

1. When Smart Fan Function activates for the first time, this calibrate function would auto-run to get upper and lower limitation of CPU Fan and System Fan.
2. When calibrating process is done, the calibrating window will auto-close, and the main screen will show new fan speed data.







**v. Auto:**

If the green indicator is lit up, the Smart Fan Function is “On” (Default Setting).

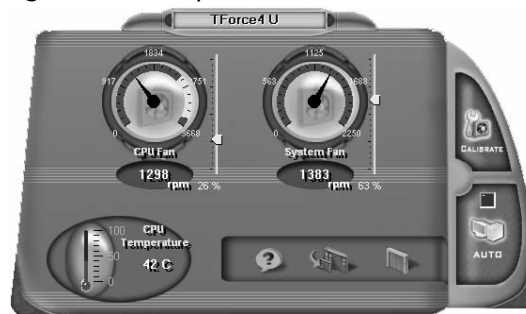
Click on this button again to close Smart Fan Function, and a screen as below would pop-up.

There will be pulling-meter besides the CPU Fan and System Fan, the CPU Fan and the System Fan speed can be adjusted by adjusting the Cursor Up or Down.

**vi. Program Tool Bar:**

-  **About:**  
Click on this button to get program-related information.
-  **Minimize:**  
Click on this button to minimize the program to system tray
-  **Exit:**  
Click on this button to exit this program.

### D. Live Update



When Live Update program is activated, a screen will pop up to illustrate BIOS related information.

**i. Link to Internet:**

Click on this button will link to Biostar website and BIOS file will be downloaded.

**ii. Update BIOS:**

Click on this button to run BIOS flashing process, and it's easy and safe.

**iii. Backup BIOS:**

Click on this button, and BIOS file will be saved into the user-selected folder.

**iv. Clear CMOS:**

Click on this item will clear the CMOS Data. When carrying this job, the previous CMOS data would be cleared and returned to default setting.

## CHAPTER 6: USEFUL HELP

### 6.1 DRIVER INSTALLATION NOTE

After you installed your operating system, please insert the Fully Setup Driver CD into your optical drive and install the driver for better system performance.

You will see the following window after you insert the CD

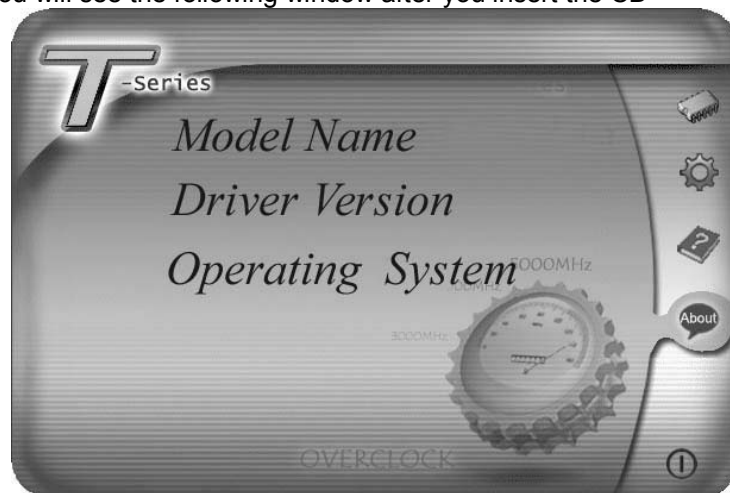

The setup guide will auto detect your motherboard and operating system.

**Note:**

If this window didn't show up after you insert the Driver CD, please use file browser to locate and execute the file **SETUP.EXE** under your optical drive.

#### A. Driver Installation

To install the driver, please click on the Driver icon. The setup guide will list the compatible driver for your motherboard and operating system. Click on each device driver to launch the installation program.

#### B. Software Installation

To install the software, please click on the Software icon. The setup guide will list the software available for your system, click on each software title to launch the installation program.

#### C. Manual

Aside from the paperback manual, we also provide manual in the Driver CD. Click on the Manual icon to browse for available manual.

**Note:**

You will need Acrobat Reader to open the manual file. Please download the latest version of Acrobat Reader software from <http://www.adobe.com/products/acrobat/readstep2.html>

## 6.2 AWARD BIOS BEEP CODE

Beep Sound	Meaning
One long beep followed by two short beeps	Video card not found or video card memory bad
High-low siren sound	CPU overheated System will shut down automatically
One Short beep when system boot-up	No error found during POST
Long beeps every other second	No DRAM detected or install

## 6.3 EXTRA INFORMATION

### A. BIOS Update

After you fail to update BIOS or BIOS is invaded by virus, the Boot-Block function will help to restore BIOS. If the following message is shown after boot-up the system, it means the BIOS contents are corrupted.

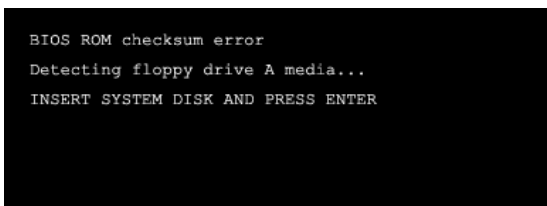

In this Case, please follow the procedure below to restore the BIOS:

1. Make a bootable floppy disk.
2. Download the Flash Utility "AWDFLASH.exe" from the Biostar website: [www.biostar.com.tw](http://www.biostar.com.tw)
3. Confirm motherboard model and download the respectively BIOS from Biostar website.
4. Copy "AWDFLASH.exe" and respectively BIOS into floppy disk.
5. Insert the bootable disk into floppy drive and press Enter.
6. System will boot-up to DOS prompt.
7. Type "Awdflash xxxx.bf/sn/py/r" in DOS prompt.  
(xxxx means BIOS name.)
8. System will update BIOS automatically and restart.
9. The BIOS has been recovered and will work properly.

**B. CPU Overheated**

If the system shutdown automatically after power on system for seconds, that means the CPU protection function has been activated.

When the CPU is over heated, the motherboard will shutdown automatically to avoid a damage of the CPU, and the system may not power on again.

In this case, please double check:

1. The CPU cooler surface is placed evenly with the CPU surface.
2. CPU fan is rotated normally.
3. CPU fan speed is fulfilling with the CPU speed.

After confirmed, please follow steps below to relief the CPU protection function.

1. Remove the power cord from power supply for seconds.
2. Wait for seconds.
3. Plug in the power cord and boot up the system.

Or you can:

1. Clear the CMOS data.  
(See "Close CMOS Header: JCMOS1" section)
2. Wait for seconds.
3. Power on the system again.

## 6.4 TROUBLESHOOTING

Probable	Solution
<ol style="list-style-type: none"> <li>1. No power to the system at all. Power light don't illuminate, fan inside power supply does not turn on.</li> <li>2. Indicator light on keyboard does not turn on.</li> </ol>	<ol style="list-style-type: none"> <li>1. Make sure power cable is securely plugged in.</li> <li>2. Replace cable.</li> <li>3. Contact technical support.</li> </ol>
<p>System inoperative. Keyboard lights are on, power indicator lights are lit, and hard drive is spinning.</p>	<p>Using even pressure on both ends of the DIMM, press down firmly until the module snaps into place.</p>
<p>System does not boot from hard disk drive, can be booted from optical drive.</p>	<ol style="list-style-type: none"> <li>1. Check cable running from disk to disk controller board. Make sure both ends are securely plugged in; check the drive type in the standard CMOS setup.</li> <li>2. Backing up the hard drive is extremely important. All hard disks are capable of breaking down at any time.</li> </ol>
<p>System only boots from optical drive. Hard disk can be read and applications can be used but booting from hard disk is impossible.</p>	<ol style="list-style-type: none"> <li>1. Back up data and applications files.</li> <li>2. Reformat the hard drive. Re-install applications and data using backup disks.</li> </ol>
<p>Screen message says "Invalid Configuration" or "CMOS Failure."</p>	<p>Review system's equipment. Make sure correct information is in setup.</p>
<p>Cannot boot system after installing second hard drive.</p>	<ol style="list-style-type: none"> <li>1. Set master/slave jumpers correctly.</li> <li>2. Run SETUP program and select correct drive types. Call the drive manufacturers for compatibility with other drives.</li> </ol>

This page is intentionally left blank.

**APPENDENCIES: SPEC IN OTHER LANGUAGE****GERMAN**

Spezifikationen		
CPU	Socket AM2 AMD Athlon 64 / Athlon 64 FX / Athlon 64 x2/ Sempron Prozessoren	Die AMD 64-Architektur unterstützt eine 32-Bit- und 64-Bit-Datenverarbeitung Unterstützt Hyper Transport und Cool'n'Quiet
FSB	Unterstützt HyperTransport mit einer Bandbreite von bis zu 1 GHz	
Chipsatz	AMD 690G AMD SB600	
Super E/A	ITE 8716F Bietet die häufig verwendeten alten Super E/A-Funktionen. Low Pin Count-Schnittstelle	Umgebungskontrolle, Hardware-Überwachung Lüfterdrehzahl-Controller "Smart Guardian"-Funktion von ITE
Arbeitsspeicher	DDR2 DIMM-Steckplätze x 4 Max. 4GB Arbeitsspeicher	Jeder DIMM unterstützt 256/512MB & 1GB DDR2. Dual-Kanal DDR2 Speichermodul Unterstützt DDR2 400 / 533 / 667 / 800 registrierte DIMMs. ECC DIMMs werden nicht unterstützt.
Grafik	Integrierter AMD 690G-Chipsatz	Max. 512MB gemeinsam benutzter Videospeicher
IDE	Integrierter IDE-Controller	Ultra DMA 33 / 66 / 100 / 133 Bus Master-Modus Unterstützt PIO-Modus 0~4,
SATA II	Integrierter Serial ATA-Controller Datenübertragungsraten bis zu 3Gb/s	Konform mit der SATA-Spezifikation Version 2.0.
LAN	Realtek 8111B(PCI-E)	10 / 100 Mb/s und 1Gb/s Auto-Negotiation Halb-/ Voll duplex-Funktion
Audio-Codec	ALC 888 / Integrierter AMD 690G (HDMI audio)	7.1-Kanal-Audioausgabe (ALC888) 2-Kanal-Audioausgabe (HDMI Audio) Unterstützt High-Definition Audio
Steckplätze	PCI-Steckplatz x2 PCI Express x16 Steckplatz x1 PCI Express x 1-Steckplatz x1	
Onboard-Anschluss	Diskettenlaufwerkanschluss x1 Druckeranschluss Anschluss x1 IDE-Anschluss x1 SATA-Anschluss x4	Jeder Anschluss unterstützt 2 Diskettenlaufwerke Jeder Anschluss unterstützt 1 Druckeranschluss Jeder Anschluss unterstützt 2 IDE-Laufwerke Jeder Anschluss unterstützt 1 SATA-Laufwerk



Spezifikationen			
	Fronttafelanschluss	x1	Unterstützt die Fronttafel-funktionen
	Front-Audioanschluss	x1	Unterstützt die Fronttafel-Audioanschlussfunktion
	CD-IN-Anschluss	x1	Unterstützt die CD Audio-In-Funktion
	S/PDIF- Ausgangsanschluss	x1	Unterstützt die digitale Audioausgabefunktion
	S/PDIF Eingangsanschluss (optional)	x1	Unterstützt die digitale Audioeingabefunktion
	CPU-Lüfter-Sockel	x1	CPU-Lüfterstromversorgungsanschluss (mit Smart Fan-Funktion)
	System-Lüfter-Sockel	x3	System-Lüfter-Stromversorgungsanschluss
	"CMOS löschen"-Sockel	x1	
	USB-Anschluss	x3	Jeder Anschluss unterstützt 2 Fronttafel-USB-Anschlüsse
	Serieller Anschluss	x1	
	Stromanschluss (24-polig)	x1	
	Stromanschluss (4-polig)	x1	
Rückseiten-E/A	PS/2-Tastatur	x1	
	PS/2-Maus	x1	
	S-Video-Anschluss	x1	
	HDMI-Anschluss	x1	
	VGA-Anschluss	x1	
	DVI-D-Anschluss	x1	
	LAN-Anschluss	x1	
	USB-Anschluss	x4	
	Audioanschluss	x6	
Platinengröße	244 mm (B) X 244 mm (L)		
Sonderfunktionen	Unterstützt RAID 0 / 1 / 1+0		
OS-Unterstützung	Windows XP / VISTA		Biostar behält sich das Recht vor, ohne Ankündigung die Unterstützung für ein Betriebssystem hinzuzufügen oder zu entfernen.

**FRANCE**

SPEC		
UC	Socket AM2 Processeurs AMD Athlon 64 / Athlon 64 FX / Athlon 64 x2/ Sempron	L'architecture AMD 64 permet le calcul 32 et 64 bits Prend en charge Hyper Transport et Cool'n'Quiet
Bus frontal	Prend en charge Hyper Transport jusqu'à une bande passante de 1 GHz	
Chipset	AMD 690G AMD SB600	
Super E/S	ITE 8716F Fournit la fonctionnalité de Super E/S patrimoniales la plus utilisée. Interface à faible compte de broches	Initiatives de contrôle environnementales, Moniteur de matériel Contrôleur de vitesse de ventilateur Fonction "Gardien intelligent" de l'ITE
Mémoire principale	Fentes DDR2 DIMM x 4 Capacité mémoire maximale de 4 Go	Chaque DIMM prend en charge des DDR2 de 256/512 Mo et 1Go Module de mémoire DDR2 à mode à double voie Prend en charge la DDR2 400 / 533 / 667 / 800 Les DIMM à registres et DIMM avec code correcteurs d'erreurs ne sont pas prises en charge
Graphiques	Intégré dans la chipset AMD 690G	Mémoire vidéo partagée maximale de 512 Mo
IDE	Contrôleur IDE intégré	Mode principale de Bus Ultra DMA 33 / 66 / 100 / 133 Prend en charge le mode PIO 0~4,
SATA SATA II	Contrôleur Serial ATA intégré : Taux de transfert jusqu'à 3 Go/s.	Conforme à la spécification SATA Version 2.0
LAN	Realtek 8111B(PCI-E)	10 / 100 Mb/s et 1 Gb/s négociation automatique Half / Full duplex capability
Codec audio	ALC 888 / Intégré dans la AMD 690G (HDMI audio)	Sortie audio à 7.1 voies (ALC888) Sortie audio à 2 voies (HDMI audio) Prise en charge de l'audio haute définition
Fentes	Fente PCI x2 Slot PCI Express x16 x1 Slot PCI Express x 1 x1	
Connecteur embarqué	Connecteur de disquette x1 Connecteur de Port d'imprimante x1 Connecteur IDE x1	Chaque connector prend en charge 2 lecteurs de disquettes Chaque connector prend en charge 1 Port d'imprimante Chaque connecteur prend en charge 2 périphériques IDE

SPEC			
	Connecteur SATA	x4	Chaque connecteur prend en charge 1 périphérique SATA
	Connecteur du panneau avant	x1	Prend en charge les équipements du panneau avant
	Connecteur Audio du panneau avant	x1	Prend en charge la fonction audio du panneau avant
	Connecteur d'entrée CD	x1	Prend en charge la fonction d'entrée audio de CD
	Connecteur de sortie S/PDIF	x1	Prend en charge la fonction de sortie audio numérique
	Connecteur d'entrée S/PDIF (en option)	x1	Prend en charge la fonction d'entrée audio numérique
	Embase de ventilateur UC	x1	Alimentation électrique du ventilateur UC (avec fonction de ventilateur intelligent)
	Embase de ventilateur système	x3	Alimentation électrique du ventilateur système
	Embase d'effacement CMOS	x1	
	Connecteur USB	x3	Chaque connecteur prend en charge 2 ports USB de panneau avant
	Connecteur de Port série	x1	
	Connecteur d'alimentation (24 broches)	x1	
	Connecteur d'alimentation (4 broches)	x1	
E/S du panneau arrière	Clavier PS/2	x1	
	Souris PS/2	x1	
	Port S-Video	x1	
	Port HDMI	x1	
	Port VGA	x1	
	Port DVI-D	x1	
	Port LAN	x1	
	Port USB	x4	
	Fiche audio	x6	
Dimensions de la carte	244 mm (l) X 244 mm (H)		
Fonctionnalités spéciales	Prise en charge RAID 0 / 1 / 1+0		
Support SE	Windows XP / VISTA		Biostar se réserve le droit d'ajouter ou de supprimer le support de SE avec ou sans préavis.

**ITALIAN**

SPECIFICA		
CPU	Socket AM2 Processori AMD Athlon 64 / Athlon 64 FX / Athlon 64 x2/ Sempron	L'architettura AMD 64 abilita la computazione 32 e 64 bit Supporto di Hyper Transport e Cool'n'Quiet
FSB	Supporto di HyperTransport fino a 1 GHz di larghezza di banda	
Chipset	AMD 690G AMD SB600	
Super I/O	ITE 8716F Fornisce le funzionalità legacy Super I/O usate più comunemente. Interfaccia LPC (Low Pin Count)	Funzioni di controllo dell'ambiente: Monitoraggio hardware Controller velocità ventolina Funzione "Smart Guardian" di ITE
Memoria principale	Alloggi DIMM DDR2 x 4 Capacità massima della memoria 4GB	Ciascun DIMM supporta DDR2 256/512MB e 1GB Modulo di memoria DDR2 a canale doppio Supporto di DDR2 400 / 533 / 667 / 800 DIMM registrati e DIMM ECC non sono supportati
Grafica	Integrata nel Chipset AMD 690G	La memoria video condivisa massima è di 512MB
IDE	Controller IDE integrato	Modalità Bus Master Ultra DMA 33 / 66 / 100 / 133 Supporto modalità PIO Mode 0-4
SATA II	Controller Serial ATA integrato Velocità di trasferimento dei dati fino a 3 Gb/s.	Compatibile specifiche SATA Versione 2.0.
LAN	Realtek 8111B(PCI-E)	Negoziazione automatica 10 / 100 Mb/s e 1Gb/s Capacità Half / Full Duplex
Codec audio	ALC 888 / Integrata nel AMD 690G (HDMI audio)	Uscita audio 7.1 canali (ALC888) Uscita audio 2 canali (HDMI audio) Supporto audio High-Definition (HD)
Alloggi	Alloggio PCI x2 Alloggio PCI Express x16 x1 Alloggio PCI Express x1 x1	
Connettori su scheda	Connettore floppy x1 Connettore Porta stampante x1 Connettore IDE x1 Connettore SATA x4	Ciascun connettore supporta 2 unità Floppy Ciascun connettore supporta 1 Porta stampante Ciascun connettore supporta 2 unità IDE Ciascun connettore supporta 1 unità SATA

SPECIFICA		
	Connettore pannello frontale x1 Connettore audio frontale x1 Connettore CD-in x1 Connettore output SPDIF x1 Connettore input S/SPDIF (optional) x1 Collettore ventolina CPU x1 Collettore ventolina sistema x3 Collettore cancellazione CMOS x1 Connettore USB x3 Connettore Porta seriale x1 Connettore alimentazione (24 pin) x1 Connettore alimentazione (4 pin) x1	Supporta i servizi del pannello frontale Supporta la funzione audio pannello frontale Supporta la funzione input audio CD Supporta la funzione d'output audio digitale Supporta la funzione d'input audio digitale Alimentazione ventolina CPU (con funzione Smart Fan) Alimentazione ventolina di sistema Ciascun connettore supporta 2 porte USB pannello frontale
I/O pannello posteriore	Tastiera PS/2 x1 Mouse PS/2 x1 Porta S-Video x1 Porta HDMI x1 Porta VGA x1 Porta DVI-D x1 Porta LAN x1 Porta USB x4 Connettore audio x6	
Dimensioni scheda	244 mm (larghezza) x 244 mm (altezza)	
Caratteristiche speciali	Supporto RAID 0 / 1 / 1+0	
Sistemi operativi supportati	Windows XP / VISTA	Biostar si riserva il diritto di aggiungere o rimuovere il supporto di qualsiasi sistema operativo senza preavviso.

**SPANISH**

Especificación		
CPU	Conector AM2 Procesadores AMD Athlon 64 / Athlon 64 FX / Athlon 64 x2/ Sempron	La arquitectura AMD 64 permite el procesado de 32 y 64 bits Soporta las tecnologías Hyper Transport y Cool'n'Quiet
FSB	Admite HyperTransport con un ancho de banda de hasta 1 GHz	
Conjunto de chips	AMD 690G AMD SB600	
Súper E/S	ITE 8716F Le ofrece las funcionalidades heredadas de uso más común Súper E/S. Interfaz de cuenta Low Pin	Iniciativas de control de entorno, Monitor hardware Controlador de velocidad de ventilador Función "Guardia inteligente" de ITE
Memoria principal	Ranuras DIMM DDR2 x 4 Capacidad máxima de memoria de 4GB	Cada DIMM admite DDR de 256/512MB y 1GB Módulo de memoria DDR2 de canal Doble Admite DDR2 de 400 / 533 / 667 / 800 No admite DIMM registrados o DIMM compatibles con ECC
Gráficos	Integrados en el conjunto de chips AMD 690G	Memoria máxima de vídeo compartida de 512MB
IDE	Controlador IDE integrado	Modo bus maestro Ultra DMA 33 / 66 / 100 / 133 Soporte los Modos PIO 0~4,
SATA II	Controlador ATA Serie Integrado Tasas de transferencia de hasta 3 Gb/s.	Compatible con la versión SATA 2.0.
Red Local	Realtek 8111B(PCI-E)	Negociación de 10 / 100 Mb/s y 1 Gb/s Funciones Half / Full dúplex
Códecs de sonido	ALC 888 / Integrados en el conjunto de AMD 690G (HDMI sonido)	Salida de sonido de 7.1 canales (ALC888) Salida de sonido de 2 canales (HDMI sonido) Soporte de sonido Alta Definición
Ranuras	Ranura PCI X2 Ranura PCI Express x16 X1 Ranura PCI express x 1 X1	
Conectores en placa	Conector disco flexible X1 Conector Puerto de impresora X1 Conector IDE X1 Conector SATA X4	Cada conector soporta 2 unidades de disco flexible Cada conector soporta 1 Puerto de impresora Cada conector soporta 2 dispositivos IDE Cada conector soporta 1 dispositivos SATA

Especificación			
	Conector de panel frontal	X1	Soporta instalaciones en el panel frontal
	Conector de sonido frontal	X1	Soporta funciones de sonido en el panel frontal
	Conector de entrada de CD	X1	Soporta función de entrada de sonido de CD
	Conector de salida S/PDIF	X1	Soporta función de salida de sonido digital
	Conector de entrada S/PDIF (opcional)	x1	Soporta función de entrada de sonido digital
	Cabecera de ventilador de CPU	X1	Fuente de alimentación de ventilador de CPU (con función Smart Fan)
	Cabecera de ventilador de sistema	X3	Fuente de alimentación de ventilador de sistema
	Cabecera de borrado de CMOS	X1	
	Conector USB	X3	Cada conector soporta 2 puertos USB frontales
	Conector Puerto serie	X1	
	Conector de alimentación (24 patillas)	X1	
	Conector de alimentación (4 patillas)	X1	
Panel trasero de E/S	Teclado PS/2	X1	
	Ratón PS/2	X1	
	Puerto S-Video	X1	
	Puerto HDMI	X1	
	Puerto VGA	X1	
	Puerto DVI-D	X1	
	Puerto de red local	X1	
	Puerto USB	X4	
	Conector de sonido	X6	
Tamaño de la placa	244 mm. (A) X 244 Mm. (H)		
Funciones especiales	Admite RAID 0 / 1 / 1+0		
Soporte de sistema operativo	Windows XP / VISTA		Biostar se reserva el derecho de añadir o retirar el soporte de cualquier SO con o sin aviso previo.

**PORTUGUESE**

ESPECIFICAÇÕES		
CPU	Socket AM2 Processadores AMD Athlon 64 / Athlon 64 FX / Athlon 64 x2/ Sempron	A arquitectura AMD 64 permite uma computação de 32 e 64 bits Suporta as tecnologias Hyper Transport e Cool'n'Quiet
FSB	Suporta a tecnologia HyperTransport com uma largura de banda até 1 GHz	
Chipset	AMD 690G AMD SB600	
Especificação do Super I/O	ITE 8716F Proporciona as funcionalidades mais utilizadas em termos da especificação Super I/O. Interface LPC (Low Pin Count).	Iniciativas para controlo do ambiente Monitorização do hardware Controlador da velocidade da ventoinha Função "Smart Guardian" da ITE
Memória principal	Ranuras DIMM DDR2 x 4 Capacidade máxima de memória: 4 GB	Cada módulo DIMM suporta uma memória DDR2 de 256/512 MB & 1 GB Módulo de memória DDR2 de canal duplo Suporta módulos DDR2 400 / 533 / 667 / 800 Os módulos DIMM registados e os DIMM ECC não são suportados
Placa gráfica	Integrada no chipset AMD 690G	Memória de vídeo máxima partilhada: 512 MB
IDE	Controlador IDE integrado	Modo Bus master Ultra DMA 33 / 66 / 100 / 133 Suporta o modo PIO 0~4,
SATA II	Controlador Serial ATA integrado Velocidades de transmissão de dados até 3 Gb/s.	Compatibilidade com a especificação SATA versão 2.0.
LAN	Realtek 8111B(PCI-E)	Auto negociação de 10 / 100 Mb/s e 1Gb/s Capacidade semi/full-duplex
Codec de som	ALC 888 / Integrada no AMD 690G (HDMI áudio)	Saída de áudio de 7.1 canais (ALC888) Saída de áudio de 2 canais (HDMI áudio) Suporta a especificação High-Definition Audio
Ranuras	Ranhura PCI x2 Ranhura PCI Express x16 x1 Ranhura PCI Express x 1 x1	
Conectores na placa	Conector da unidade de disquetes x1 Conector da para impressora x1 Conector IDE x1	Cada conector suporta 2 unidades de disquetes Cada conector suporta 1 Porta para impressora Cada conector suporta 2 dispositivos IDE



ESPECIFICAÇÕES			
	Conector SATA	x4	Cada conector suporta 1 dispositivo SATA
	Conector do painel frontal	x1	Para suporte de várias funções no painel frontal
	Conector de áudio frontal	x1	Suporta a função de áudio no painel frontal
	Conector para entrada de CDs	x1	Suporta a entrada de áudio a partir de CDs
	Conector de saída S/PDIF	x1	Suporta a saída de áudio digital
	Conector de entrada S/PDIF (opcional)	x1	Suporta a entrada de áudio digital
	Conector da ventoinha da CPU	x1	Alimentação da ventoinha da CPU (com a função Smart Fan)
	Conector da ventoinha do sistema	x3	Alimentação da ventoinha do sistema
	Conector para limpeza do CMOS	x1	
	Conector USB	x3	Cada conector suporta 2 portas USB no painel frontal
	Conector da Porta série	x1	
	Conector de alimentação (24 pinos)	x1	
	Conector de alimentação (4 pinos)	x1	
Entradas/Saídas no painel traseiro	Teclado PS/2	x1	
	Rato PS/2	x1	
	Porta S-Video	x1	
	Porta HDMI	x1	
	Porta VGA	x1	
	Porta DVI-D	x1	
	Porta LAN	x1	
	Porta USB	x4	
	Tomada de áudio	x6	
Tamanho da placa	244 mm (L) X 244 mm (A)		
Características especiais	Suporta as funções RAID 0 / 1 / 1+0		
Sistemas operativos suportados	Windows XP / VISTA		A Biostar reserva-se o direito de adicionar ou remover suporte para qualquer sistema operativo com ou sem aviso prévio.

**POLISH**

SPEC		
Procesor	Socket AM2 AMD Athlon 64 / Athlon 64 FX / Athlon 64 x2/ Sempron Procesory	Architektura AMD 64 umożliwia przetwarzanie 32 i 64 bitowe Obsługa Hyper Transport oraz Cool'n'Quiet
FSB	Obsługa HyperTransport o szerokości pasma do 1 GHz	
Chipset	AMD 690G AMD SB600	
Pamięć główna	Gniazda DDR2 DIMM x 4 Maks. wielkość pamięci 4GB	Każde gniazdo DIMM obsługuje moduły 256/512MB oraz 1GB DDR2 Moduł pamięci DDR2 z trybem podwójnego kanału Obsługa DDR2 400 / 533 / 667 / 800 Brak obsługi Registered DIMM oraz ECC DIMM
Super I/O	ITE 8716F Zapewnia najbardziej powszechne funkcje Super I/O. Interfejs Low Pin Count	Funkcje kontroli warunków pracy, Monitor H/W Kontroler prędkości wentylatora Funkcja ITE "Smart Guardian"
Grafika	Zintegrowana w chipsecie AMD 690G	Maks. wielkość współdzielonej pamięci video wynosi 512MB
IDE	Zintegrowany kontroler IDE	Ultra DMA 33 / 66 / 100 / 133 Tryb Bus Master obsługa PIO tryb 0~4,
SATA II	Zintegrowany kontroler Serial ATA Transfer danych do 3 Gb/s.	Zgodność ze specyfikacją SATA w wersji 2.0.
LAN	Realtek 8111B(PCI-E)	10 / 100 Mb/s oraz 1Gb/s z automatyczną negocjacją szybkości Działanie w trybie połowicznego / pełnego duplexu
Kodek dźwiękowy	ALC 888 / Zintegrowana w AMD 690G (HDMI audio)	7.1 kanałowe wyjście audio (ALC888) 2 kanałowe wyjście audio (HDMI audio) Obsługa High-Definition Audio
Gniazda	Gniazdo PCI x2 Gniazdo PCI Express x16 x1 Gniazdo PCI Express x 1 x1	
Złącza wbudowane	Złącze napędu dyskiety x1 Złącze Port drukarki x1 Złącze IDE x1	Każde złącze obsługuje 2 napędy dyskiety Każde złącze obsługuje 1 Port drukarki Każde złącze obsługuje 2 urządzenia IDE

SPEC			
	Złącze SATA	x4	Każde złącze obsługuje 1 urządzenie SATA
	Złącze panela przedniego	x1	Obsługa elementów panela przedniego
	Przednie złącze audio	x1	Obsługa funkcji audio na panelu przednim
	Złącze wejścia CD	x1	Obsługa funkcji wejścia audio CD
	Złącze wyjścia S/PDIF	x1	Obsługa funkcji cyfrowego wyjścia audio
	Złącze wejścia S/PDIF (opcja)	x1	Obsługa funkcji cyfrowego wejścia audio
	Złącze główkowe wentylatora procesora	x1	Zasilanie wentylatora procesora (z funkcją Smart Fan)
	Złącze główkowe wentylatora systemowego	x3	Zasilanie wentylatora systemowego
	Złącze główkowe kasowania CMOS	x1	
	Złącze USB	x3	Każde złącze obsługuje 2 porty USB na panelu przednim
	Złącze Port szeregowy	x1	
	Złącze zasilania (24 pinowe)	x1	
	Złącze zasilania (4 pinowe)	x1	
Back Panel I/O	Klawiatura PS/2	x1	
	Mysz PS/2	x1	
	Port S-Video	x1	
	Port HDMI	x1	
	Port VGA	x1	
	Port DVI-D	x1	
	Port LAN	x1	
	Port USB	x4	
	Gniazdo audio	x6	
Wymiary płyty	244 mm (S) X 244 mm (W)		
Funkcje specjalne	Obsługa RAID 0 / 1 / 1+0		
Obsługa systemu operacyjnego	Windows XP / VISTA		Biostar zastrzega sobie prawo dodawania lub odwoływania obsługi dowolnego systemu operacyjnego bez powiadomienia.

## RUSSIAN

СПЕЦ.		
CPU (центральный процессор)	Гнездо AM2 Процессоры AMD Athlon 64 / Athlon 64 FX / Athlon 64X2 / Sempron	Архитектура AMD 64 разрешать обработка данных на 32 и 64 бит Поддержка Hyper Transport и Cool'n'Quiet
FSB	Поддержка HyperTransport с пропускной способностью до 1ГГц	
Набор микросхем	AMD 690G AMD SB600	
Основная память	Слоты DDR2 DIMM x 4 Максимальная ёмкость памяти 4 Гб	Каждый модуль DIMM поддерживает 256/512МБ & 1ГБ DDR2 Модуль памяти с двухканальным режимом DDR2 Поддержка DDR2 400 / 533 / 667 / 800 Не поддерживает зарегистрированные модули DIMM and ECC DIMM
Super I/O	ITE 8716F Обеспечивает наиболее используемые действующие функциональные возможности Super I/O. Интерфейс с низким количеством выводов	Инициативы по охране окружающей среды, Аппаратный монитор Регулятор скорости Функция ITE "Smart Guardian" (Интеллектуальная защита)
Графика	Встроенная в набор микросхем AMD 690G	Максимальная совместно используемая видео память составляет 512 МБ
IDE	Встроенное устройство управления встроенными интерфейсами устройств	Режим "хозяина" шины Ultra DMA 33 / 66 / 100 / 133 Поддержка режима PIO 0~4,
SATA II	Встроенное последовательное устройство управления ATA	скорость передачи данных до 3 гигабит/с. Соответствие спецификации SATA версия 2.0.
Локальная сеть	Realtek 8111B(PCI-E)	Автоматическое согласование 10 / 100 Мб/с и 1Гб/с Частичная / полная дуплексная способность
Звуковой кодек	ALC888 / Встроенная в набор микросхем AMD 690G (HDMI)	Звуковая поддержка High-Definition 7.1канальный звуковой выход (ALC888) 2канальный звуковой выход (HDMI)
Слоты	Слот PCI x2 Слот PCI Express x16 x1 Слот PCI Express x 1 x1	
Встроенный разъём	Разъём НГМД x1 Разъём Порт подключения принтера x1 Разъём IDE x1	Каждый разъём поддерживает 2 накопителя на гибких магнитных дисках Каждый разъём поддерживает 1 Порт подключения принтера Каждый разъём поддерживает 2 встроенных интерфейса накопителей

СПЕЦ.			
	Разъём SATA	x4	Каждый разъём поддерживает 1 устройство SATA
	Разъём на лицевой панели	x1	Поддержка устройств на лицевой панели
	Входной звуковой разъём	x1	Поддержка звуковых функций на лицевой панели
	Разъём ввода для CD	x1	Поддержка функции ввода для CD
	Разъём вывода для S/PDIF	x1	Поддержка вывода цифровой звуковой функции
	Разъём ввода для S/PDIF (дополнительно)	x1	Поддержка ввода цифровой звуковой функции
	Контактирующее приспособление вентилятора центрального процессора	x1	Источник питания для вентилятора центрального процессора (с функцией интеллектуального вентилятора)
	Контактирующее приспособление вентилятора системы	x3	Источник питания для вентилятора системы
	Открытое контактирующее приспособление CMOS	x1	
	USB-разъём	x3	Каждый разъём поддерживает 2 USB-порта на лицевой панели
	Разъём Последовательный порт	x1	
	Разъём питания (24 вывод)	x1	
	Разъём питания (4 вывод)	x1	
Задняя панель средств ввода-вывода	Клавиатура PS/2	x1	
	Мышь PS/2	x1	
	Порт S-Video	x1	
	Порт HDMI	x1	
	Порт VGA	x1	
	Порт DVI-D	x1	
	Порт LAN	x1	
	USB-порт	x4	
	Гнездо для подключения наушников	x6	
Размер панели	244 мм (Ш) X 244 мм (В)		
Специальные технические характеристики	Поддержка RAID 0 / 1 / 1+0		
Поддержка OS	Windows XP / VISTA		Biostar сохраняет за собой право добавлять или удалять средства обеспечения для OS с или без предварительного уведомления.

## ARABIC

المواصفات		
وحدة المعالجة المركزية	AM2 مقبس AMD Athlon 64 / Athlon 64 FX / Athlon 64 x2/ Sempron	إجراء العمليات الحاسوبية بسرعة 32 و 64 بت AMD 64 تمكين تقنية Cool'n'Quiet و Hyper Transport تدعم تقنية
النقل الأممي الجانبي	1000 يتردد يصل إلى HyperTransport تدعم تقنية تردد	
مجموعة الشرائح	AMD 690G AMD SB600	
الذاكرة الرئيسية	قناة DDR2 DIMM سعة ذاكرة قصوى 4 جيجا بايت	ميجا بايت و 1 جيجا 256/512 سعة DDR2 تدعم ذاكرة من نوع DIMM تدعم كل قناة بايت مزدوجة القناة DDR2 وحدة ذاكرة سعت 400 / 533 / 667 / 800 ميجا بايت DDR2 تدعم الذاكرة من نوع ECC وتلك التي لا تتوافق مع DIMM لا تدعم رقائق الذاكرة
Super I/O	ITE 8716F الأكثر استخداماً، Super I/O يوفر وظيفة Low Pin Count Interface تدعم تقنية	وسائل التحكم في البيئة: مراقب لمعرفة حالة الأجهزة مراقب في سرعة المروحة ITE من "Smart Guardian" وظيفة
بطاقة الرسومات	AMD 690G مدمجة في رقائق	ميجا بايت 512 أقصى سعة لذاكرة الفيديو المشتركة
منفذ IDE	متكامل IDE متحكم	وضع رئيسي 33 / 66 / 100 / 133 Ultra DMA النقل بتقنية PIO Mode 0~4 دعم وضع
SATA II	متكامل Serial ATA متحكم نقل البيانات بسرعة تصل إلى 3 جيجابايت/ثانية.	2.0، الإصدار SATA مطابقة لمواصفات
شبكة داخلية	Realtek 8111B (PCI-E)	تفويض تلقائي 10/100 ميجا بايت / ثنائية و 1 جيجابايت/ثانية إمكانية النقل المزدوج الكامل/النصفي
كوديك الصوت	ALC888 / AMD 690G (HDMI) مدمجة في رقائق	قنوات لخرج الصوت 7.1 (ALC888) قنوات لخرج الصوت 2 (HDMI) تدعم تقنية الصوت على التعريف من
الفتحات	قناة PCI قناة PCI Express x16 قناة PCI Express x1	عدد 2 عدد 1 عدد 1

## TA690G AM2

المواصفات		
منفذ محرك أقراص مرنة	عدد 1	يدعم محركين للأقراص المرنة
منفذ طباعة	عدد 1	
منفذ IDE	عدد 1	يدعم كل منفذ اثنين من أجهزة IDE
منفذ SATA	عدد 4	يدعم كل منفذ واحد من أجهزة SATA
منفذ اللوحة الأممية	عدد 1	يدعم تجهيزات اللوحة الأممية
منفذ الصوت الأمامي	عدد 1	يدعم وظيفة الصوت باللوحة الأممية
منفذ CD-IN	عدد 1	يدعم وظيفة دخل صوت القرص المدمج
منفذ خرج S/PDIF	عدد 1	يدعم وظيفة خرج الصوت الرقمي
منفذ دخل S/PDIF (اختياري)	عدد 1	يدعم وظيفة دخل الصوت الرقمي
وصلة مروحة وحدة المعالجة المركزية	عدد 1	Smart Fan (توصيل الطاقة لمروحة وحدة المعالجة مع وظيفة لتوصيل الطاقة لمروحة النظام
وصلة مروحة النظام	عدد 3	
وصلة مسح CMOS	عدد 1	
منفذ USB	عدد 3	باللوحة الأممية USB يدعم كل منفذ فتحتي
منفذ تسلسلي	عدد 1	
منفذ توصيل الطاقة (24 دبوس)	عدد 1	
منفذ توصيل الطاقة (4 دبوس)	عدد 1	
لوحة مفاتيح PS/2	عدد 1	
ماوس PS/2	عدد 1	
منافذ S-Video	عدد 1	
منافذ HDMI	عدد 1	
منافذ VGA	عدد 1	
منافذ DVI-D	عدد 1	
منفذ شبكة اتصال محلية	عدد 1	
منافذ USB	عدد 4	
مقيس صوت	عدد 6	
مزيا خاصة		RAID 0 / 1 / 1+0 تدعم تقنية
حجم اللوحة		244 مم (عرض) X 244 مم (ارتفاع)
دعم أنظمة التشغيل		Windows XP / VISTA
		بخطأ في إضافة أو إزالة لآلة دعم لأي نظام تشغيل بلخطار أو بدون لخطار. Biostar. تحفظ

## JAPANESE

仕様		
CPU	Socket AM2 AMD Athlon 64 / Athlon 64 FX / Athlon 64 x2 / Sempron プロセッサ	AMD 64アーキテクチャでは、32ビットと64ビット計算が可能です ハイパートランスポートとクールアンドクワイエットをサポートします
FSB	1GHzのバンド幅までハイパートランスポートをサポートします	
チップセット	AMD 690G AMD SB600	
メインメモリ	DDR2 DIMMスロット x 4 最大メモリ容量4GB	各DIMMは 256/512MB & 1GB DDR2をサポート デュアル チャンネルモードDDR2メモリモジュール DDR2 400 / 533 / 667 / 800をサポート 登録済みDIMMとECC DIMMはサポートされません
Super I/O	ITE 8716F もともと一般に使用されるレガシーSuper I/O機能を採用しています。 低ピンカウントインターフェイス	環境コントロールイニシアチブ、 H/Wモニター ファン速度コントローラ/ モニター ITEの「スマートガーディアン」機能
グラフィックス	AMD 690Gチップセットに統合	最大の共有ビデオメモリは512MBです
IDE	統合IDEコントローラ	Ultra DMA 33 / 66 / 100 / 133バスマスタモード PIO Mode 0~4のサポート、
SATA II	統合シリアルATAコントローラ 最高3 Gb/秒のデータ転送速度	SATAバージョン2.0仕様に準拠。
LAN	Realtek 8111B(PCI-E)	10 / 100 Mb/秒および1Gb/秒のオートネゴシエーション 半/全二重機能
サウンド Codec	ALC 888 / AMD 690Gチップセットに統合(HDMI audio)	7.1チャンネルオーディオアウト (ALC888) 2チャンネルオーディオアウト (HDMI audio) ハイデフィニションオーディオのサポート
スロット	PCIスロット x2 PCI Express x16スロット x1 PCI Express x 1スロット x1	



仕様			
オンボードコ ネクタ	フロッピーコネクタ	x1	各コネクタは2つのフロッピードライブをサポートします
	プリンタポートコネクタ	x1	各コネクタは1つのプリンタポートをサポートします
	IDEコネクタ	x1	各コネクタは2つのIDEデバイスをサポートします
	SATAコネクタ	x4	各コネクタは1つのSATAデバイスをサポートします
	フロントパネルコネクタ	x1	フロントパネル機能をサポートします
	フロントオーディオコネクタ	x1	フロントパネルオーディオ機能をサポートします
	CDインコネクタ	x1	CDオーディオイン機能をサポートします
	S/PDIFアウトコネクタ	x1	デジタルオーディオアウト機能をサポートします
	S/PDIFインコネクタ (オプション)	x1	デジタルオーディオイン機能をサポートします
	CPUファンヘッダ	x1	CPUファン電源装置(スマートファン機能を搭載)
	システムファンヘッダ	x3	システムファン電源装置
	CMOSクリアヘッダ	x1	
	USBコネクタ	x3	各コネクタは2つのフロントパネルUSBポートをサポートし ます
	シリアルポートコネクタ	x1	
電源コネクタ(24ピン)	x1		
電源コネクタ(4ピン)	x1		
背面パネル I/O	PS/2キーボード	x1	
	PS/2マウス	x1	
	S-Videoポート	x1	
	HDMIポート	x1	
	VGAポート	x1	
	DVI-Dポート	x1	
	LANポート	x1	
	USBポート	x4	
オーディオジャック	x6		
ボードサイズ	244 mm (幅) X 244 mm (高さ)		
特殊機能	RAID 0 / 1 / 1+0 のサポート		
OSサポート	Windows XP / VISTA	Biostarは事前のサポートなしにOSサポートを追加または削 除する権利を留保します。	

2007/12/26