

SUPER[®]

SUPER[®] PDSG4
SUPER[®] PDSGE

USER'S MANUAL

Revision 1.1a

The information in this User's Manual has been carefully reviewed and is believed to be accurate. The vendor assumes no responsibility for any inaccuracies that may be contained in this document, makes no commitment to update or to keep current the information in this manual, or to notify any person or organization of the updates. **Please Note: For the most up-to-date version of this manual, please see our web site at www.supermicro.com.**

Super Micro Computer, Inc. ("Supermicro") reserves the right to make changes to the product described in this manual at any time and without notice. This product, including software, if any, and documentation may not, in whole or in part, be copied, photocopied, reproduced, translated or reduced to any medium or machine without prior written consent.

IN NO EVENT WILL SUPER MICRO COMPUTER, INC. BE LIABLE FOR DIRECT, INDIRECT, SPECIAL, INCIDENTAL, SPECULATIVE OR CONSEQUENTIAL DAMAGES ARISING FROM THE USE OR INABILITY TO USE THIS PRODUCT OR DOCUMENTATION, EVEN IF ADVISED OF THE POSSIBILITY OF SUCH DAMAGES. IN PARTICULAR, SUPER MICRO COMPUTER, INC. SHALL NOT HAVE LIABILITY FOR ANY HARDWARE, SOFTWARE, OR DATA STORED OR USED WITH THE PRODUCT, INCLUDING THE COSTS OF REPAIRING, REPLACING, INTEGRATING, INSTALLING OR RECOVERING SUCH HARDWARE, SOFTWARE, OR DATA.

Any disputes arising between manufacturer and customer shall be governed by the laws of Santa Clara County in the State of California, USA. The State of California, County of Santa Clara shall be the exclusive venue for the resolution of any such disputes. Supermicro's total liability for all claims will not exceed the price paid for the hardware product.

FCC Statement: This equipment has been tested and found to comply with the limits for a Class B digital device pursuant to Part 15 of the FCC Rules. These limits are designed to provide reasonable protection against harmful interference in a residential installation. This equipment generates, uses, and can radiate radio frequency energy and, if not installed and used in accordance with the manufacturer's instruction manual, may cause interference with radio communications. However, there is no guarantee that interference will not occur in a particular installation. If this equipment does cause harmful interference to radio or television reception, which can be determined by turning the equipment off and on, you are encouraged to try to correct the interference by one or more of the following measures:

Reorient or relocate the receiving antenna.

Increase the separation between the equipment and the receiver.

Connect the equipment into an outlet on a circuit different from that to which the receiver is connected.

Consult the dealer or an experienced radio/television technician for help.

California Best Management Practices Regulations for Perchlorate Materials: This Perchlorate warning applies only to products containing CR (Manganese Dioxide) Lithium coin cells. "Perchlorate Material-special handling may apply. See www.dtsc.ca.gov/hazardouswaste/perchlorate".

WARNING: Handling of lead solder materials used in this product may expose you to lead, a chemical known to the State of California to cause birth defects and other reproductive harm.

Manual Revision 1.1a

Release Date: February 25, 2009

Unless you request and receive written permission from Super Micro Computer, Inc., you may not copy any part of this document.

Information in this document is subject to change without notice. Other products and companies referred to herein are trademarks or registered trademarks of their respective companies or mark holders.

Copyright © 2009 by Super Micro Computer, Inc.

All rights reserved.

Printed in the United States of America

Preface

About This Manual

This manual is written for system integrators, PC technicians and knowledgeable PC users. It provides information for the installation and use of the SUPER[®] PDSG4/PDSGE motherboard. The PDSG4/PDSGE supports single Intel Pentium D (Dual-Core)/Pentium 4 Extreme Edition/Pentium 4/Pentium Extreme Edition/Celeron D LGA (Land Grid Array) 775 Processors at system bus speeds of 1066 MHz/800 MHz/533 MHz. The LGA 775 Pentium D/Pentium 4/Celeron D Processor is housed in a Flip-Chip Land Grid Array (FC-LGA4) package that interfaces with the motherboard via an LGA775 socket. The PDSG4/PDSGE supports the Intel Hyper-Threading (HT) Technology, the EM64T Technology, the Enhanced Intel SpeedStep Technology (EIST) and the Matrix Storage Technology. Please refer to the motherboard specifications pages on our web site (<http://www.supermicro.com/Product>) for updates or visit Intel's web site for processor support. This product is intended to be professionally installed and serviced by a technician.

Manual Organization

Chapter 1 describes the features, specifications and performance of the PDSG4/PDSGE mainboard and provides detailed information about the chipset.

Chapter 2 provides hardware installation instructions. Read this chapter when installing the processor, memory modules and other hardware components into the system. If you encounter any problems, see **Chapter 3**, which describes troubleshooting procedures for the video, the memory and the system setup stored in CMOS.

Chapter 4 includes an introduction to BIOS and provides detailed information on running the CMOS Setup utility.

Appendix A provides BIOS POST Messages.

Appendix B lists BIOS POST Codes.

Appendix C lists Software Installation Instructions.

Conventions used in this Manual

Special attention should be given to the following symbols for proper installation and to prevent damage done to the components or injury to yourself:



Danger/ Caution: Instructions to be strictly followed to prevent catastrophic system failure or to avoid bodily injury.



Warning: Important information given to ensure proper system installation or to prevent damage to the components.

Table of Contents

Preface

About This Manual	iii
Manual Organization	iii
Manual Convention	iii

Chapter 1: Introduction

1-1 Overview	1-1
Checklist	1-1
Contacting Supermicro	1-2
SUPER [®] PDSG4/PDSGE Image	1-3
SUPER [®] PDSG4 Layout.....	1-4
SUPER [®] PDSG4 Quick Reference.....	1-5
SUPER [®] PDSGE Layout	1-6
SUPER [®] PDSGE Quick Reference	1-7
Motherboard Features	1-8
Intel 955X (Glenwood) Chipset: System Block Diagram	1-10
1-2 Chipset Overview	1-11
1-3 PC Health Monitoring	1-12
1-4 Power Configuration Settings	1-12
1-5 Power Supply.....	1-13
1-6 Super I/O	1-14

Chapter 2: Installation

2-1 Static-Sensitive Devices	2-1
2-2 Processor and Heatsink Installation	2-2
2-3 Mounting the Motherboard in the Chassis	2-5
2-4 Installing DDR 2 Memory	2-6
2-5 I/O Port/Front Control Panel Connector Locations	2-7
2-6 Connecting Cables	2-8
Power Supply Connectors	2-8
NMI Button	2-9
Power LED	2-9
HDD LED	2-10
NIC1 LED Indicator	2-10
OH/Fan Fail LED.....	2-11
Reset Button.....	2-11
Power Button.....	2-12
Chassis Intrusion.....	2-12

Serial Ports.....	2-13
CD Header/Audio Header	2-13
Universal Serial Bus (USB).....	2-14
G-LAN (Ethernet) Port.....	2-15
PS2 Keyboard/Mouse	2-15
Fan Headers	2-16
Wake-On-Ring.....	2-17
Wake-On-LAN	2-17
Power LED	2-18
FP Audio.....	2-18
2-7 Jumper Settings	2-19
Explanation of Jumpers	2-19
GLAN Enable/Disable	2-19
CMOS Clear	2-20
Watch Dog Enable	2-20
USB Wake-Up	2-21
SMB to PCE-X/PCI-E Slots.....	2-22
Keyboard Wake-Up	2-22
SCSI Enable.....	2-23
SCSI Termination Enable	2-23
2-8 LED Indicators	2-24
G-LAN LEDs	2-24
2-9 Parallel Port, Floppy/Hard Drive and Audio Connections	2-25
Parallel Port Connector	2-25
Floppy Connector	2-26
IDE Connector	2-27
SCSI Connectors	2-28

Chapter 3: Troubleshooting

3-1 Troubleshooting Procedures	3-1
Before Power On.....	3-1
No Power.....	3-1
No Video	3-1
Memory Errors.....	3-2
Losing the System's Setup Configuration	3-2
3-2 Technical Support Procedures	3-2
3-3 Frequently Asked Questions	3-3
3-4 Returning Merchandise for Service	3-5

Chapter 4: BIOS

4-1	Introduction	4-1
4-2	Running Setup	4-2
4-3	Main BIOS Setup	4-2
	Main BIOS Setup Menu	4-3
4-4	Advanced BIOS Setup.....	4-4
	4-4.1 Advanced BIOS Features.....	4-4
	4-4.2 Advanced Chipset Control.....	4-6
	4-4.3 I/O Device Configuration	4-7
	4-4.4 PnP Configuration	4-8
	4-4.5 Hardware Monitors	4-9
	4-4.6 Processor & Clock Options	4-10
	4-4.7 DMI Event Log	4-11
	4-4.8 Console Redirection	4-11
4-5	Security	4-12
4-6	Boot	4-13
4-7	Exit	4-14

Appendices:

Appendix A: BIOS POST Messages	A-1
Appendix B: BIOS POST Codes.....	B-1
Appendix C: Software Installation Instructions.....	C-1

Chapter 1

Introduction

1-1 Overview

Checklist

Congratulations on purchasing your computer motherboard from an acknowledged leader in the industry. Supermicro boards are designed with the utmost attention to detail to provide you with the highest standards in quality and performance.

Please check that the following items have all been included with your motherboard. If anything listed here is damaged or missing, contact your retailer.

All are Included in the Retail Box Only

One (1) Supermicro Mainboard

One (1) IDE cable (CBL-036)

One (1) floppy drive ribbon cable (CBL-022)

One (1) SCSI cable (CBL-034-0320) (*PDSG4 only)

Two (2) SATA cables (CBL-044) (*For retail only)

One (1) I/O shield (CBL-PT37A)

One (1) Supermicro CD containing drivers and utilities (*PDSG4 only)

One (1) User's/BIOS Manual

Contacting Supermicro

Headquarters

Address: SuperMicro Computer, Inc.
980 Rock Ave.
San Jose, CA 95131 U.S.A.

Tel: +1 (408) 503-8000

Fax: +1 (408) 503-8008

Email: marketing@supermicro.com (General Information)
support@supermicro.com (Technical Support)

Web Site: www.supermicro.com

Europe

Address: SuperMicro Computer B.V.
Het Sterrenbeeld 28, 5215 ML
's-Hertogenbosch, The Netherlands

Tel: +31 (0) 73-6400390

Fax: +31 (0) 73-6416525

Email: sales@supermicro.nl (General Information)
support@supermicro.nl (Technical Support)
rma@supermicro.nl (Customer Support)

Asia-Pacific

Address: SuperMicro, Taiwan
4F, No. 232-1 Liancheng Road
Chung-Ho 235, Taipei Hsien, Taiwan, R.O.C.

Tel: +886-(2) 8226-3990

Fax: +886-(2) 8226-3991

Web Site: www.supermicro.com.tw

Technical Support:

Email: support@supermicro.com.tw

Tel: 886-2-8228-1366, ext.132 or 139

Figure 1-1. SUPER[®] PDSG4/PDSGE Image

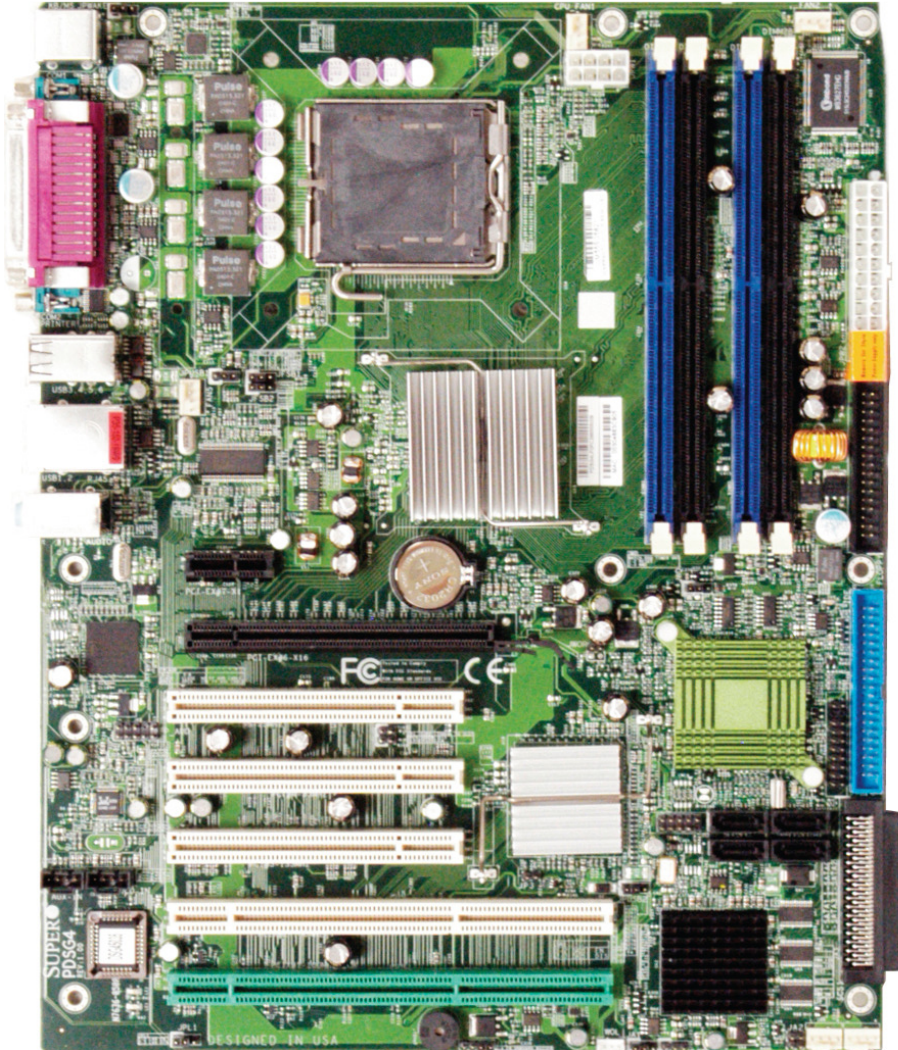

An Important Note to the User

- All images and layouts shown in this manual are based upon the latest PCB Revision available at the time of publishing. The motherboard you've received may or may not look exactly the same as the ones shown in this manual.

Figure 1-3A. The PDSG4 Motherboard Layout
(not drawn to scale)

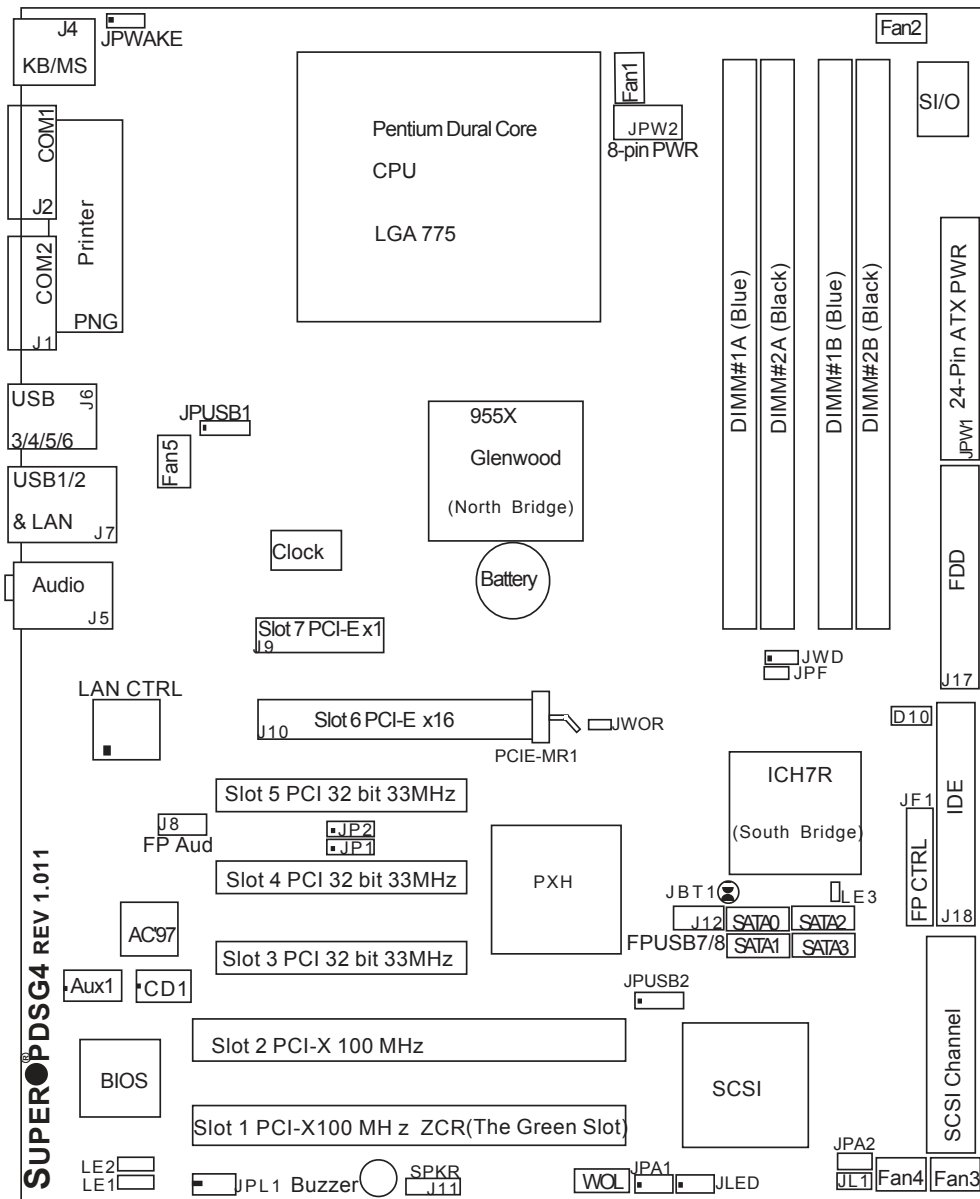

Important Notes to the User

- All images and layouts shown in this manual are based upon PCB Rev. 1.0 which is the latest PCB Revision available at the time of publishing of this manual. The motherboard you've received may or may not look exactly the same as the graphics shown in this manual.
- See Chapter 2 for detailed information on jumpers, I/O ports and JF1 front panel connections.
- "■" indicates the location of "Pin 1".
- The PDSGE supports PCI-X 133MHz and the PDSG4 supports PCI-100MHz.
- For the system to function properly, please install the ZCR Card in the Green PCI slot.
- SCSI and PCI-X ZCR (Green Slot) are for the PDSG4 only

PDSG4 Quick Reference

Jumpers	Description	Default Setting
FP Aud	Front Panel Audio Enable	(*See Chapter 2)
JPA1	SCSI Channel Enable	Pins 1-2 (Enabled)
JPA2	SCSI Channel Term. Enable	Open (Enabled)
JBT1	CMOS Clear	See Section 2-7
JP1/JP2	SMB to PCI Slots	Open/Open (Disabled)
JPF	Power Force-on	Open (Disabled)
JPL1	Giga-bit LAN Enable	Pins 1-2 (Enabled)
JPUSB1	BP USB Wake Up (USB 1-6)	Pins 2-3 (Disabled)
JPUSB2	FP USB Wake Up (USB7/8)	Pins 2-3 (Disabled)
JPWAKE	KB/Mouse Wake-Up	Pins 2-3 (Disabled)
JWD	Watch Dog Enable	Pins 1-2 (Reset)

Connectors	Description
ATX (JPW1)	ATX 24-Pin Power Connector
AUX. PWR (JPW2)	12V 8-pin Power Connector (Required)
Audio (J5)	Audio Port (Line-In, Line-Out, Microphone)
AUX (AUX1)	Auxiliary (Audio) Input Header
CD In (CD1)	Audio CD Input Header
COM1(J2), COM2(J1)	COM Port 1 & Port 2 Connectors
DIMM#1A,#2A,#1B,#2B	Memory (DIMM) Slots (1 through 4)
Fans 1-5	Fan1: CPU Fan, Fan2/3/4/5: Chassis Fan Headers
FP Audio (J8)	Front Panel Audio Header (*See Chapter 2)
FP Control (JF1)	Front Panel Control Header
Floppy Connector(J17)	Floppy Disk Connector
IDE(J18)	IDE Connector
Speaker (J11)	4-pin Speaker Header (Open: External Speaker, Pins 3-4 Closed: Internal buzzer enable)
JL1	Chassis Intrusion Header
JLED	Power LED
KB/Mouse (J4)	PS/2 Keyboard/Mouse
LAN Port	Ethernet RJ45 (Gigabit LAN) Connector
Parallel (PNG)	Printer Port
SATA #0-3	4 SATA Headers
USB1/2(J7), USB3-6(J6)	Back Panel Universal Serial Ports 1-6
USB7/8(J12)	Front Panel USB headers 7/8
WOL(WOL)	Wake On LAN header
WOR(JWOR)	Wake On Ring header

LED Indicators	Description
LE 1/LE2	System Debug Indicators (See Appendix A for details)
LE3	+5V Standby PWR LED Indicator (On: AC PWR On)

Figure 1-3B. The PDSGE Motherboard Layout
(not drawn to scale)

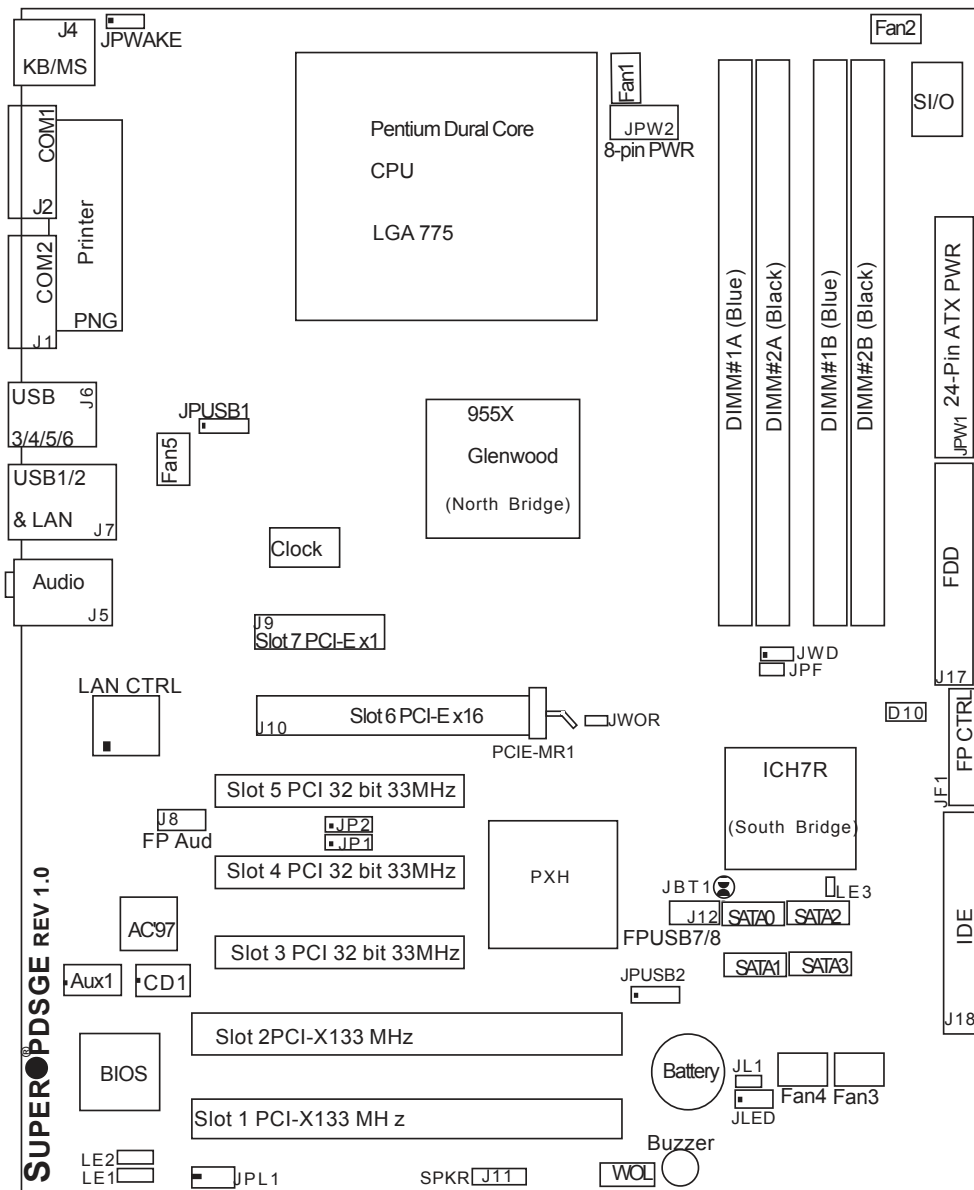

Important Notes to the User

- All images and layouts shown in this manual are based upon PCB Rev. 1.0 which is the latest PCB Revision available at the time of publishing of this manual. The motherboard you've received may or may not look exactly the same as the graphics shown in this manual.
- See Chapter 2 for detailed information on jumpers, I/O ports and JF1 front panel connections.
- "■" indicates the location of "Pin 1".
- The PDSGE supports PCI-X 133MHz and the PDSG4 supports PCI-100MHz.
- For the system to function properly, please install the ZCR Card in the Green PCI slot.
- SCSI and PCI-X 100MHz ZCR (Green Slot) are for the PDSG4 only.

PDSGE Quick Reference

Jumpers	Description	Default Setting
FP Aud	Front Panel Audio Enable	(*See Chapter 2)
JBT1	CMOS Clear	See Section 2-7
JP1/JP2	SMB to PCI Slots	Open/Open (Disabled)
JPF	Power Force-on	Open (Disabled)
JPL1	Giga-bit LAN Enable	Pins 1-2 (Enabled)
JUSB1	BP USB Wake Up (USB 1-6)	Pins 2-3 (Disabled)
JUSB2	FP USB Wake Up (USB7/8)	Pins 2-3 (Disabled)
JPWAKE	KB/Mouse Wake-Up	Pins 2-3 (Disabled)
JWD	Watch Dog Enable	Pins 1-2 (Reset)

Connectors	Description
ATX (JPW1)	ATX 24-Pin Power Connector
AUX. PWR (JPW2)	12V 8-pin Power Connector (Required)
Audio (J5)	Audio Port (Line-In, Line-Out, Microphone)
AUX (AUX1)	Auxiliary (Audio) Input Header
CD In (CD1)	Audio CD Input Header
COM1(J2), COM2(J1)	COM Port 1 & Port 2 Connectors
DIMM#1A,#2A,#1B,#2B	Memory (DIMM) Slots (1 through 4)
Fans 1-5	Fan1: CPU Fan, Fan2/3/4/5: Chassis Fan Headers
FP Audio (J8)	Front Panel Audio Header (*See Chapter 2)
FP Control (JF1)	Front Panel Control Header
Floppy Connector(J17)	Floppy Disk Connector
IDE(J18)	IDE Connector
Speaker (J11)	4-pin Speaker Header (Open: External Speaker, Pins 3-4 Closed: Internal buzzer enable)
JL1	Chassis Intrusion Header
JLED	Power LED
KB/Mouse (J4)	PS/2 Keyboard/Mouse
LAN Port	Ethernet RJ45 (Gigabit LAN) Connector
PWR-Force On (JPF)	Power Force-on Connector
Parallel (PNG)	Printer Port
SATA #0-3	4 SATA Headers
USB1/2(J7), USB3-6(J6)	Back Panel Universal Serial Ports 1-6
USB7/8(J12)	Front Panel USB headers 7/8
WOL(WOL)	Wake On LAN header
WOR(JWOR)	Wake On Ring header

LED Indicators	Description
LE 1/LE2	System Debug Indicators (See Appendix A for details)
LE3	+5V Standby PWR LED Indicator (On: AC PWR On)

Motherboard Features

CPU

- Single Intel Pentium D (Dual-Core)/Pentium 4 Extreme Edition/Pentium 4/Pentium Extreme Edition/Celeron D LGA (Land Grid Array) 775 Processors at system bus speeds of 1066 MHz/800 MHz/533 MHz.
- Hyper-Threading (HT), EM64T, Enhanced Intel SpeedStep (EIST) supported

Using the EM64T Feature

- Use a CPU that supports the EM64T Technology
- Install a 64-bit OS (Windows XP Professional x64 Ed, Server 2003x64 Ed.)
- Install the 64-bit drivers for all MB components, devices and add-on cards

Using the Hyper-Threading (HT) Technology

- Use a CPU that supports Hyper-Threading Technology
- Install an OS that supports HT, including Windows XP/2003 Server and Linux 2.4x. (Under Linux, use the HT compiler to compile the code. For other operating systems, be sure to disable the HT feature in the BIOS.)
- Enable the HT feature in the BIOS (under "Advanced" Setting) before installing a supported OS. (*Note: visit www.Intel.com for CPU support and driver updates.)

OS Licensing Support

- Intel Dual-Core CPU supports: Windows 2000 Professional, Windows Advanced Server, Windows XP Home, Windows XP Professional, Windows Server 2003 (Standard, Enterprise)
- Intel Dual-Core CPU and Hyper-Threading Technology supports: Windows 2000 Advanced Server, Windows XP Home, Windows XP Professional, Windows Server 2003 (Standard, Enterprise)

Memory

- Four DIMM slots support Dual/Single Channel DDR2 667/533/400 MHz up to 8 GB of Unbuffered ECC two-way interleaved DDR2 SDRAM.
- Supporting Intel Memory Pipeline Technology

Chipset

- Intel Glenwood 955X
- Intel ICH7R

Expansion Slots

- One (1) PCI-Express x16 (Slot 6)
- One (1) PCI-Express x1 (Slot 7)
- One (1) PCI-X 133 MHz (PDSGE) (Slot 1)
100 MHz (PDSG4) ZCR (*Green Slot) (Slot 1) (PDSG4)
- One (1) PCI-X 133 MHz (PDSGE)/100 MHz (PDSG4) (Slot 2)
- Three (3) 32-bit PCI 33MHz (5V) (Slots 3-5)

BIOS

- 8 Mb Firmware Hub AwardBIOS® Flash BIOS
- DMI 2.3, PCI 2.2, ACPI 1.0, Plug and Play (PnP)

PC Health Monitoring

- Onboard voltage monitors for CPU core, Chipset Voltage, Memory Voltage, +3.3V, +3.3V standby, +5V, +5V standby, +12V, -12V and VBAT
- Fan status monitor with firmware speed control
- SuperDoctor III, NMI• Environmental temperature monitoring via BIOS/SD III
- Power-up mode control for recovery from AC power loss
- System overheat/Fan Fail LED and control
- System resource alert via Supero Doctor III

ACPI Features

- Slow blinking LED for suspend state indicator
- BIOS support for USB keyboard
- Main switch override mechanism
- Internal/external modem ring-on

Onboard I/O

- 1 ATA/100 EIDE Channel
- Adaptec 7901 Single channel Ultra 320 SCSI (*PDSG4 only)
- Adaptec SCSI RAID 20105/Supermicro AOC-LPZCR supported (PDSG4 Only)
- Intel ICH7R Controller supports up to 4 Serial ATA (SATA) 3Gb/s Hard Disks
- Intel Matrix Storage Manager supports RAID 0, 1, 10 and 5
- 1 floppy port interface (up to 2.88 MB)
- 2 Fast UART 16550 compatible serial ports
- 1 ECP/EPP parallel port
- Single Intel 82573V PCI-E Gigabit Ethernet Controller
- PS/2 mouse and PS/2 keyboard ports
- Up to 8 USB (Universal Serial Bus) 2.0 ports for a speed of up to 480Mbps
- AC'97 audio high quality 6-channel sound

Other

- Wake-on-LAN (WOL)
- Wake-on-Ring (WOR)
- Multiple CPU clock frequency ratio selections (set in the BIOS), User-defined Overclocking in BIOS
- Suspend-to-RAM
- Onboard +5vsb warning LED Indicator ("LE3")

CD Utilities

- BIOS flash upgrade utility
- Drivers and software for Intel 955X chipset utilities

Dimensions

- ATX form factor, 12" x 9.5" (305 x 228.6 mm)
-

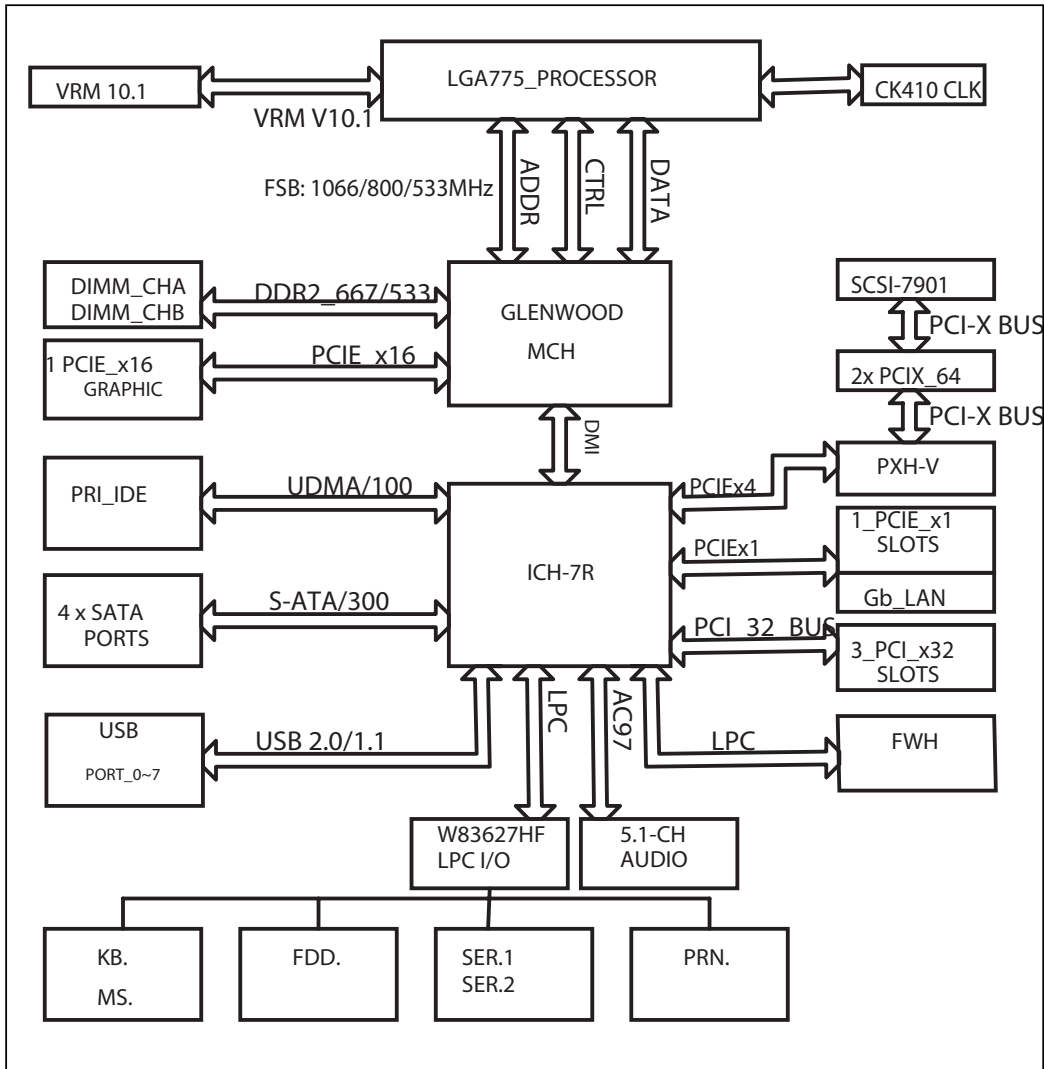

**Figure 1-3. 955X Glenwood Chipset:
System Block Diagram**

Note: This is a general block diagram and may not exactly represent the features on your motherboard. See the following pages for the actual specifications of each motherboard.

1-2 Chipset Overview

Intel's Glenwood (955X) chipset, designed for use with the Pentium 4 Dual Core LGA 775 CPU, is comprised of two primary components: the Memory Controller Hub (MCH) and the I/O Controller Hub (ICH7R). In addition, Intel's PCI-X (PXH-V) is used for added functionality. The PDSG4/PDSGE provides the performance and feature-set required for the high-end desktop and the UP workstation market.

Memory Controller Hub (MCH)

The function of the MCH is to manage the data flow between four interfaces: the CPU interface, DDR2 System Memory Interface, PCI Express Interface, and the Direct Media Interface (DMI). The MCH is optimized for the Pentium 4/Pentium D processor in the 90nm process in the LGA775 Land Grid Array Package. It supports one or two channels of unbuffered ECC DDR2 SDRAM and a PCI-Express x16 external graphics port.

The I/O Controller (ICH7R) provides the data buffering and interface arbitration required for the system to operate efficiently. It also provides the bandwidth needed for the system to maintain its peak performance. The Direct Media Interface (DMI) is the interconnect between the MCH and the ICH7R. The ICH7R supports up four Serial ATA ports, eight USB 2.0 ports and two IDE devices. In addition, the ICH7R offers the Intel Matrix Storage Technology which provides various RAID options for data protection and rapid data access. It also supports an integrated High Definition Audio controller for extreme multi-media applications and offers the most advanced client management through the use of Intel Active Management technology in conjunction with Intel's next generation Gigabit Ethernet controller.

Intel ICH7R System Features

The I/O Controller Hub provides the I/O subsystem with access to the rest of the system. Functions and capabilities include:

- *PCI Express Base Specification, Rev. 1.0a-compliant
- *PCI 2.3 with support for 33 MHz PCI operations
- *ACPI Power Management Logic Support
- *Integrated Serial ATA host controller with independent DMA operation on four ports, (with support of SATA I and SATA II HDD)
- *Integrated IDE controller supports Ultra ATA 100/66/33
- *USB host interface with support for eight USB ports
- *Enhanced DMA Controller, interrupt controller, and timer functions
- *System Management Bus (SMBus) 2.0 with additional support for I²C devices
- *Low Pin Count (LPC) Interface
- *Firmware Hub (FWH) Interface
- *Audio Codec '97 Rev. 2.3 which provides a link for Audio (up to 6 channels)

1-3 PC Health Monitoring

This section describes the PC health monitoring features of the PDSG4/PDSGE. The motherboard has an onboard System Hardware Monitor chip that supports PC health monitoring.

Onboard Voltage Monitors for the CPU Core, Chipset Voltage, Memory Voltage, +3.3V Standby, +5V, +12V,-12V, +5V standby and VBAT

The onboard voltage monitor will scan these voltages continuously. Once a voltage becomes unstable, it will give a warning or send an error message to the screen. Users can adjust the voltage thresholds to define the sensitivity of the voltage monitor.

Fan Status Monitor with Firmware Speed Control

The PC health monitor can check the RPM status of the cooling fans. The onboard fans are controlled by Thermal Management via BIOS.

CPU Overheat LED and Control

This feature is available when the user enables the CPU overheat warning function in the BIOS. This allows the user to define an overheat temperature. When this temperature reaches the threshold, the CPU thermal trip feature will be activated and it will send a signal to the Speaker LED and, at the same time, the CPU speed will be decreased.

1-4 Power Configuration Settings

This section describes features of your motherboard that deal with power and power settings.

Slow Blinking LED for Suspend-State Indicator

When the CPU goes into a suspend state, the chassis power LED will start blinking to indicate that the CPU is in suspend mode. When the user presses any key, the CPU will wake-up and the LED will automatically stop blinking and remain on.

BIOS Support for USB Keyboard

If the USB keyboard is the only keyboard in the system, it will function like a normal keyboard during system boot-up.

Main Switch Override Mechanism

When an ATX power supply is used, the power button can function as a system suspend button to make the system enter a SoftOff state. The monitor will be

suspended and the hard drive will spin down. Pressing the power button again will cause the whole system to wake-up. During the SoftOff state, the ATX power supply provides power to keep the required circuitry in the system alive. In case the system malfunctions and you want to turn off the power, just press and hold the power button for 4 seconds. This option can be set in the Power section of the BIOS Setup routine.

Wake Ring-On (WOR)

Wake-up events can be triggered by a device such as the external modem ringing when the system is in the SoftOff state. Note that external modem ring-on can only be used with an ATX 2.01 (or above) compliant power supply.

Wake-On-LAN (WOL)

Wake-On-LAN is defined as the ability of a management application to remotely power up a computer that is powered off. Remote PC setup, up-dates and asset tracking can occur after hours and on weekends so that daily LAN traffic is kept to a minimum and users are not interrupted. The motherboard has a 3-pin header (WOL) to connect to the 3-pin header on a Network Interface Card (NIC) that has WOL capability. Wake-On-LAN must be enabled in BIOS. Note that Wake-On-LAN can only be used with an ATX 2.01 (or above) compliant power supply.

1-5 Power Supply

As with all computer products, a stable power source is necessary for proper and reliable operation. It is even more important for processors that have high CPU clock rates of 1 GHz and faster.

The **SUPER** PDSG4/PDSGE accommodates 12V ATX power supplies. Although most power supplies generally meet the specifications required by the CPU, some are inadequate. A 2 amps of current supply on a 5V Standby rail is strongly recommended.

The PDSG4/PDSGE accommodates ATX power supplies. It is strongly recommended that you use a high quality power supply that meets ATX power supply Specification 2.02 or above. You should use one that will supply at least 350W of power. Also your power supply must supply 1.5A for the Ethernet ports. It must also be SSI compliant (info at <http://www.ssiforum.org/>). Additionally, in areas where noisy power transmission is present, you may choose to install a line filter to shield the computer from noise. It is recommended that you also install a power surge protector to help avoid problems caused by power surges.

1-6 Super I/O

The disk drive adapter functions of the Super I/O chip include a floppy disk drive controller that is compatible with industry standard 82077/765, a data separator, write pre-compensation circuitry, decode logic, data rate selection, a clock generator, drive interface control logic and interrupt and DMA logic. The wide range of functions integrated onto the Super I/O greatly reduces the number of components required for interfacing with floppy disk drives. The Super I/O supports two 360 K, 720 K, 1.2 M, 1.44 M or 2.88 M disk drives and data transfer rates of 250 Kb/s, 500 Kb/s or 1 Mb/s.

It also provides two high-speed, 16550 compatible serial communication ports (UARTs). Each UART includes a 16-byte send/receive FIFO, a programmable baud rate generator, complete modem control capability and a processor interrupt system. Both UARTs provide legacy speed with baud rate of up to 115.2 Kbps as well as an advanced speed with baud rates of 250 K, 500 K, or 1 Mb/s, which support higher speed modems.

The Super I/O provides functions that comply with ACPI (Advanced Configuration and Power Interface), which includes support of legacy and ACPI power management through a SMI or SCI function pin. It also features auto power management to reduce power consumption.

Chapter 2

Installation

2-1 Static-Sensitive Devices

Electro-Static Discharge (ESD) can damage electronic components. To prevent damage to your system board, it is important to handle it very carefully. The following measures are generally sufficient to protect your equipment from ESD.

Precautions

- Use a grounded wrist strap designed to prevent static discharge.
- Touch a grounded metal object before removing the board from the antistatic bag.
- Handle the board by its edges only; do not touch its components, peripheral chips, memory modules or gold contacts.
- When handling chips or modules, avoid touching their pins.
- Put the motherboard and peripherals back into their antistatic bags when not in use.
- For grounding purposes, make sure your computer chassis provides excellent conductivity between the power supply, the case, the mounting fasteners and the motherboard.
- Use only the correct type of onboard CMOS battery. Do not install the onboard upside down battery to avoid possible explosion.

Unpacking

The motherboard is shipped in antistatic packaging to avoid static damage. When unpacking the board, make sure the person handling it is static protected.

2-2 Processor and Heatsink Fan Installation



When handling the processor package, avoid placing direct pressure on the label area of the fan.

(*Notes: 1. Always connect the power cord last and always remove it before adding, removing or changing any hardware components. Make sure that you install the processor into the CPU socket before you install the CPU heatsink.

2. Intel's boxed Pentium 4 CPU package contains the CPU fan and heatsink assembly. If you buy a CPU separately, make sure that you use only Intel-certified multi-directional heatsink and fan.

3. The Intel Pentium 4 LGA 775 heatsink and fan comes with a push-pin design and no tool is needed for installation.

4. Make sure to install the motherboard into the chassis before you install the CPU heatsink and fan.)

5. When purchasing an LGA 775 CPU or when receiving a motherboard with an LGA 775 CPU pre-installed, make sure that the CPU plastic cap is in place and none of the CPU pins are bent; otherwise, contact the retailer immediately.

6. Refer to the MB Features Section for more details on CPU support.

Installation of the LGA775 Processor

Socket
Lever
Load
Plate

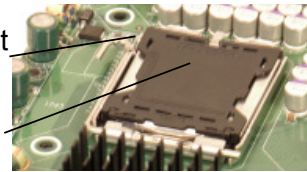

1. Press the socket lever to release the load plate, which covers the CPU socket, from its locking position.

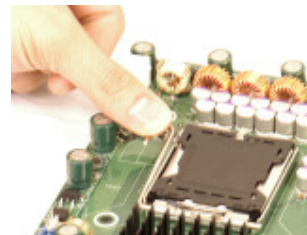

2. Gently lift the socket lever to open the load plate.

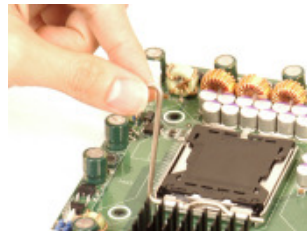

Load Plate

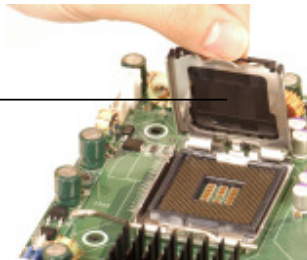

3. Locate Pin 1 on the CPU socket. (*Note: Pin 1 is the corner marked with a triangle). Please note that the North Key and the South Key are located vertically in the CPU housing.

4. Position the motherboard in such a way that Pin 1 of the CPU socket is located at the left bottom of the CPU housing.

5. Use your thumb and your index finger to hold the CPU at the North Center Edge and the South Center Edge of the CPU.

6. Align Pin 1 of the CPU with Pin 1 of the socket. Once aligned, carefully lower the CPU straight down to the socket. (**Do not drop the CPU on the socket. Do not move the CPU horizontally or vertically. Do not rub the CPU against the surface or against any pins of the socket to avoid damage to the CPU or the socket.)

7. With the CPU inside the socket, inspect the four corners of the CPU to make sure that the CPU is properly installed.

8. Use your thumb to gently push the lever down and lock it in the hook.

9. If the CPU is properly installed into the socket, the plastic cap will be automatically released from the load plate when the lever is pushed into the hook. Remove the plastic cap from the motherboard.



(*Warning: Please keep the plastic cap. The motherboard and the CPU must be shipped with the plastic cap properly installed to protect the CPU pins. Shipment without the CPU plastic cap properly installed will void the warranty.)

Plastic cap is released from the load plate if the CPU is properly installed.

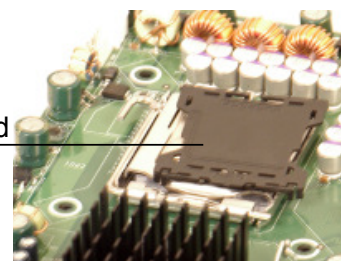
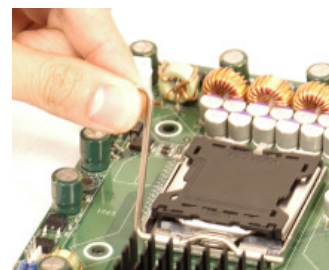
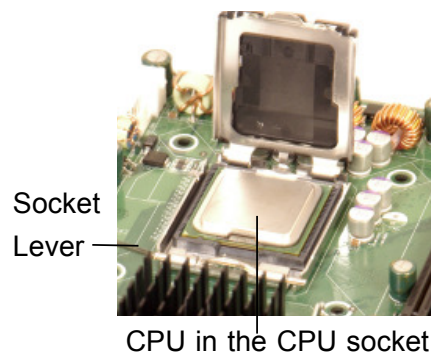
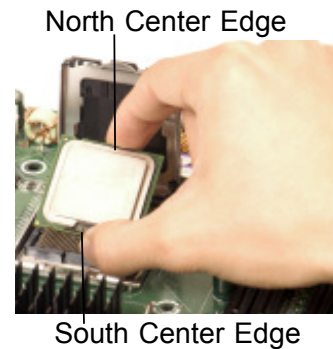
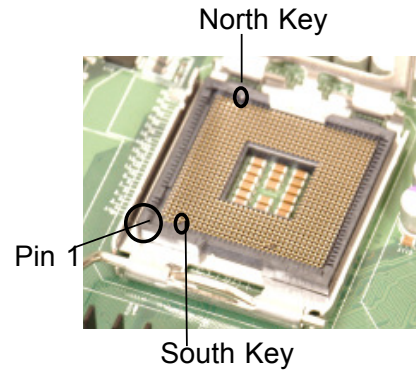

Installation of the Heatsink

1. Locate the CPU Fan on the motherboard. (Refer to the layout on the right for the CPU Fan location.)
2. Position the heatsink in such a way that the heatsink fan wires are closest to the CPU fan and are not interfered with other components.
3. Inspect the CPU Fan wires to make sure that the wires are routed through the bottom of the heatsink.
4. Remove the thin layer of the protective film from the copper core of the heatsink.

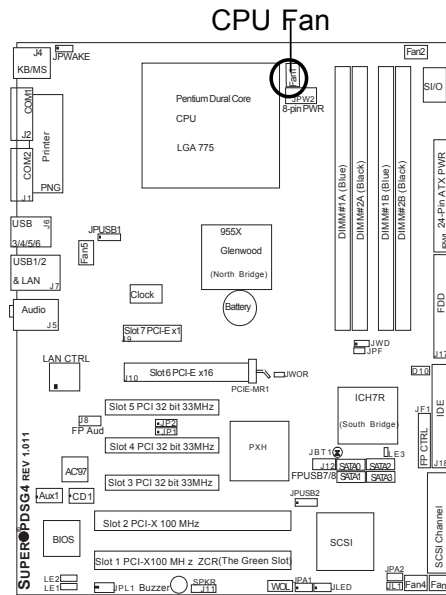

(***Warning:** CPU overheat may occur if the protective film is not removed from the heatsink.)

5. Apply the proper amount of thermal grease on the CPU. (***Note:** if your heatsink came with a thermal pad, please ignore this step.)

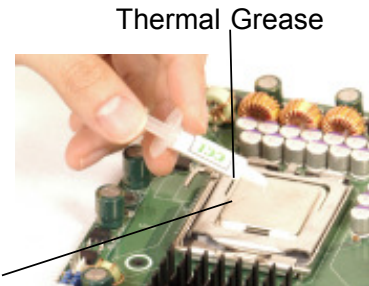

6. If necessary, rearrange the wires to make sure that the wires are not pinched between the heatsink and the CPU. Also make sure to keep clearance between the fan wires and the fins of the heatsink.

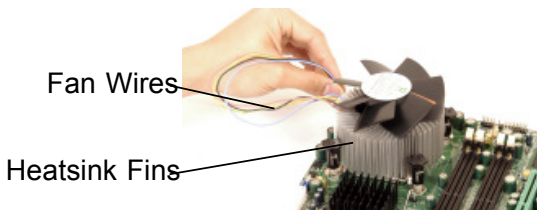

7. Align the four heatsink fasteners with the mounting holes on the motherboard. Gently push the pairs of diagonal fasteners (#1 & #2, and #3 & #4) into the mounting holes until you hear a click. (***Note:** Make sure to orient each fastener in a way that the narrow end of the groove is pointing outward.)

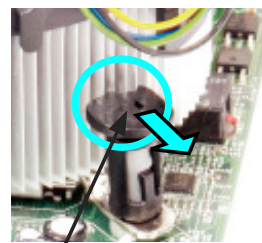
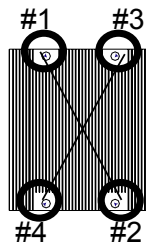
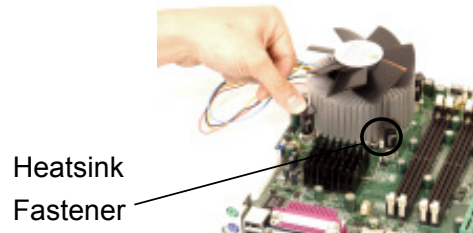

Narrow end of the groove points outward

8. Repeat Step 6 to insert all four heatsink fasteners into the mounting holes.
9. Once all four fasteners are securely inserted into the mounting holes and the heatsink is properly installed on the motherboard, connect the heatsink fan wires to the CPU Fan connector.

Heatsink Removal

1. Unplug the power cord from the power supply.
2. Disconnect the heatsink fan wires from the CPU fan header.
3. Use your finger tips to gently press on the fastener cap and turn it counterclockwise to make a 1/4 (90°) turn, and then pull the fastener upward to loosen it.
4. Repeat Step 3 to loosen all fasteners from the mounting holes.
5. With all fasteners loosened, remove the heatsink from the CPU.



2-3 Mounting the Motherboard in the Chassis

All motherboards have standard mounting holes to fit different types of chassis. Make sure that the locations of all the mounting holes for both the motherboard and the chassis match. Although a chassis may have both plastic and metal mounting fasteners, metal ones are highly recommended because they ground the motherboard to the chassis. Make sure that the metal standoffs click in or are screwed in tightly. Then use a screwdriver to secure the motherboard onto the motherboard tray. (***Note:** some components are very close to the mounting holes. Please take all necessary precautionary measures to prevent damage done to these components when installing the motherboard into the chassis.)



Caution: To avoid damaging the motherboard and its components, please do not use a force greater than 8 lb/inch on each mounting screw during motherboard installation.

2-4 Installing DDR 2 Memory

Memory Module Installation (See Figure 2-2)



Exercise extreme care when installing or removing memory modules to prevent any possible damage.

1. Insert each DDR 2 memory module vertically into its slot. Pay attention to the notch along the bottom of the module to prevent inserting the module incorrectly. (See support information below.)
2. Gently press down on the memory module until it snaps into place.

Support

The PDSG4/PDSGE supports Dual channel, ECC unbuffered DDR 2 667/533/400 SDRAM. Interleaved/non-interleaved memory are supported, so you may populate any number of DIMM slots. (Populating DIMM#1A, DIMM#1B, and/or DIMM#2A, DIMM#2B with memory modules of the same size and of the same type will result in dual channel, two-way interleaved memory which is faster than the single channel, non-interleaved memory. When ECC memory is used, it may take 25-40 seconds for the VGA to display.)

***Note 1.** Due to chipset limitation, 8GB Memory can only be supported by the following operating systems: 32-Bit: Windows 2000 Advanced Server & Windows 2003 Enterprise Edition; 64-Bit: Windows Server 2003 Standard/Enterprise/XP x64 Edition

***Note 2.** You may install a maximum of 2GB DIMMs on each slot; however, only DDR 2 533 2GB density modules are available for this configuration.

***Note 3.** Some old-version of DDR 2-667 may not match Intel's On-Die-Temperature requirement and will be automatically down-graded to run @ 533 MHz, If this occurs, contact your memory vendor to check the ODT value.)

***Note 4.** Due to memory allocation to system devices, memory remaining available for operational use will be reduced when 4 GB of RAM is used. The reduction in memory availability is disproportional. Microsoft Windows users, please see FAQ in Chapter 3 for additional information.

Possible System Memory Allocation & Availability (Total Physical Memory: 4 GB)		
System Device	Size	Physical Memory Remaining (-Available)
Firmware Hub flash memory (System BIOS)	1 MB	3.99GB
Local APIC	4 KB	3.99GB
Area Reserved for the chipset	2 MB	3.99GB
I/O APIC (4 Kbytes)	4 KB	3.99GB
PCI Enumeration Area 1	256 MB	3.76GB
PCI Express (256 MB)	256 MB	3.51GB
PCI Enumeration Area 2 (if needed) -Aligned on 256-MB boundary-	512 MB	3.01GB
VGA Memory	16 MB	2.85GB
TSEG	1 MB	2.84GB
Memory available for the OS & applications		2.84GB

Figure 2-2. Side and Top Views of DDR 2 Module Installation into Slot

To Install:
 Insert module vertically and press down until it snaps into place. Pay attention to the notch.

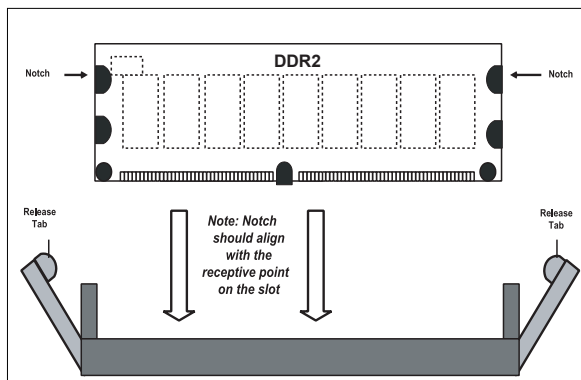

To Remove:
 Use your thumbs to gently push each release tab outwards to release the DIMM from the slot.

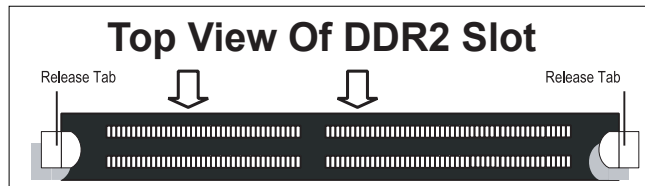

2-5 I/O Port/Control Panel Connector Locations

The I/O ports are color coded in conformance with the PC99 specification to make setting up your system easier. See Figure 2-3 below for the colors and locations of the various IO ports.

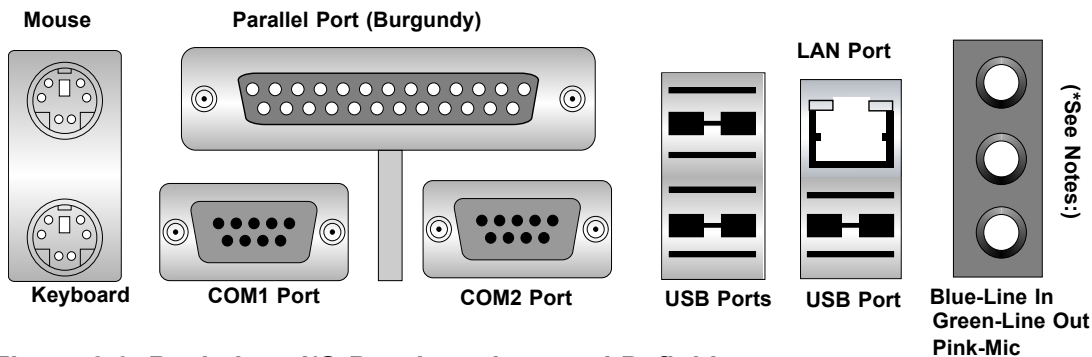

Figure 2-3. Backplane I/O Port Locations and Definitions

Front Control Panel

JF1 contains header pins for various buttons and indicators that are normally located on a control panel at the front of the chassis. These connectors are designed specifically for use with Supermicro server chassis. See Figure 2-4 for the descriptions of the various control panel buttons and LED indicators. Refer to the following section for descriptions and pin definitions.

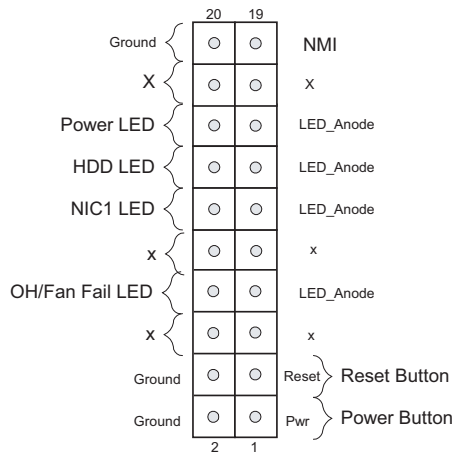

Figure 2-4. JF1 Header Pins

2-6 Connecting Cables

(*Note: the graphics shown in the chapter is based on the PDSG4. For the PDSGE Model, please refer to Page 1-6.)

ATX Power Connector

The main power supply connector (JPW1) on the PDSG4/PDSGE meets the SSI (Superset ATX) specification. You can only use a 24-pin power supply cable on the motherboard. Make sure that the orientation of the connector is correct.

ATX Power Supply 24-pin Connector
Pin Definitions

Pin Number	Definition	Pin Number	Definition
13	+3.3V	1	+3.3V
14	-12V	2	+3.3V
15	COM	3	COM
16	PS_ON#	4	+5V
17	COM	5	COM
18	COM	6	+5V
19	COM	7	COM
20	Res(NC)	8	PWR_OK
21	+5V	9	5VSB
22	+5V	10	+12V
23	+5V	11	+12V
24	COM	12	+3.3V

Processor Power Connector

In addition to the Primary ATX power connector (above), the 12V 8-pin Processor connector at JPW2 must also be connected to your power supply for CPU power consumption to avoid causing instability to the system.

8-Pin +12v Power Supply Connector

Pins	Definition
1 thru 4	Ground
5 thru 8	+12v

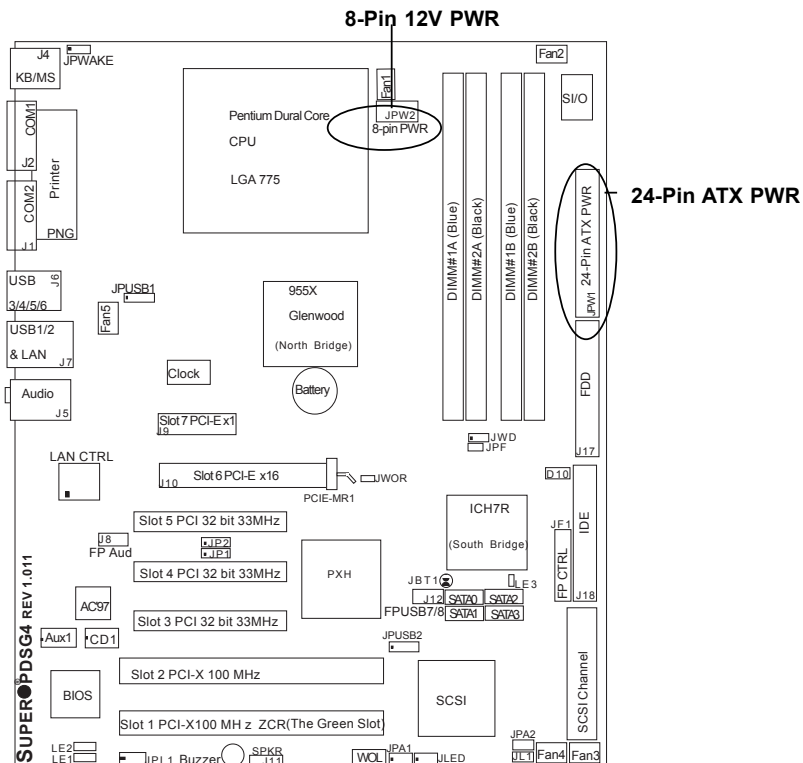

NMI Button

The non-maskable interrupt button header is located on pins 19 and 20 of JF1. Refer to the table on the right for pin definitions.

NMI LED Pin Definitions (JF1)

Pin#	Definition
19	NMI_LED Sig.
20	GND

Power LED

The Power LED connection is located on pins 15 and 16 of JF1. Refer to the table on the right for pin definitions.

PWR_LED Pin Definitions (JF1)

Pin Number	Definition
15	LED_Anode
16	PWR_LED Sig.

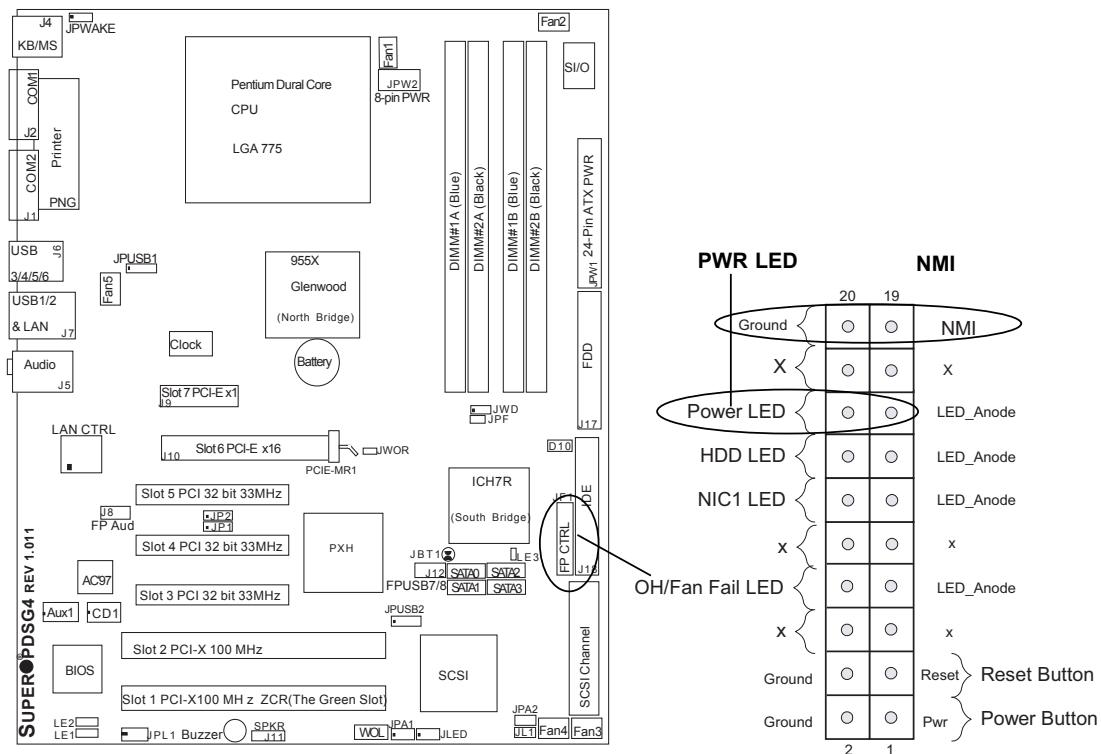

HDD LED

The HDD LED connection is located on pins 13 and 14 of JF1. Attach the hard drive LED cable here to display disk activity (for any hard drives on the system, including SCSI, Serial ATA and IDE). See the table on the right for pin definitions.

HDD LED Pin Definitions (JF1)

Pin Number	Definition
13	LED_Anode
14	HD Active

NIC1 LED Indicators

The NIC (Network Interface Controller) LED connections for the GLAN port1 is located on pins 11 and 12 of JF1. Attach the NIC LED cables to display network activity. Refer to the tables on the right for pin definitions.

NIC1 LED Pin Definitions (JF1)

Pin#	Definition
11	LED_Anode
12	NIC1 LED Sig.

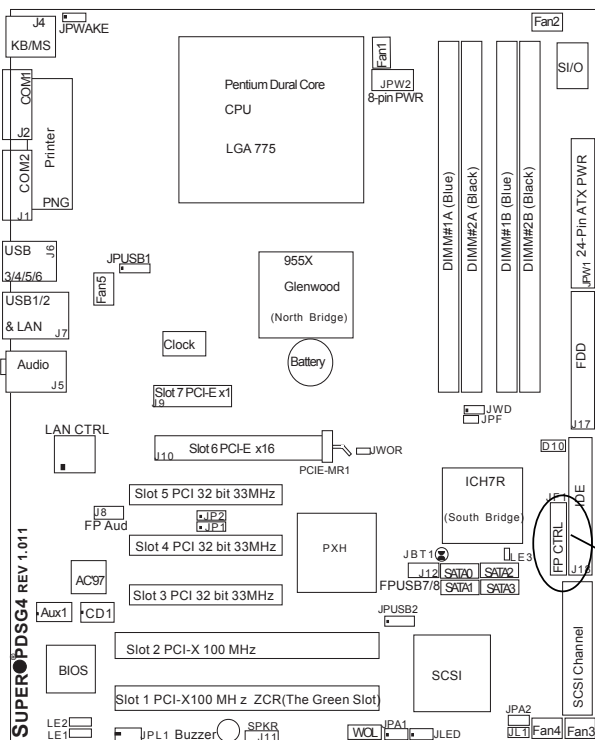

HDD LED
NIC1 LED

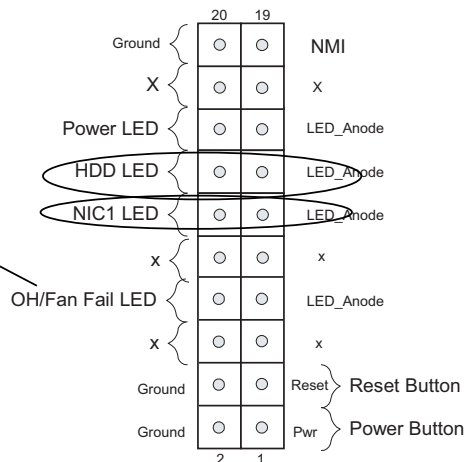

Overheat/FanFail LED

Connect an LED to the OH/Fan Fail connection on pins 7 and 8 of JF1 to provide advanced warnings of chassis overheating or system fan failure. Refer to the table on the right for pin definitions.

Overheat (OH)/ Fan_Fail LED Pin Definitions (JF1)

Pin #	Definition
7	LED_Anode
8	OH/Fan Fail LED Sig.

OH/Fan Fail LED (JF1)

State	Message
Off	Normal
Stay On	Overheat
Blink	Fan Fail

Reset Button

The Reset Button connection is located on pins 3 and 4 of JF1. Attach it to the hardware reset switch on the computer case. Refer to the table on the right for pin definitions.

Reset Pin Definitions (JF1)

Pin Number	Definition
3	Reset
4	Ground

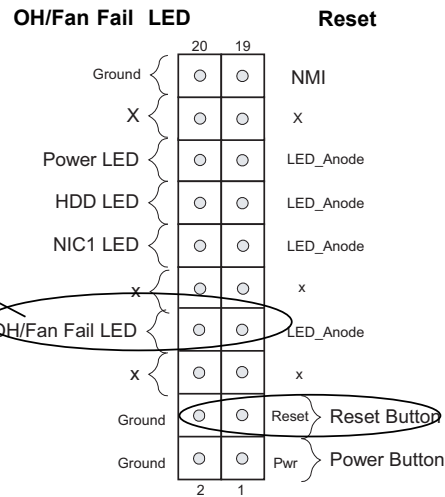
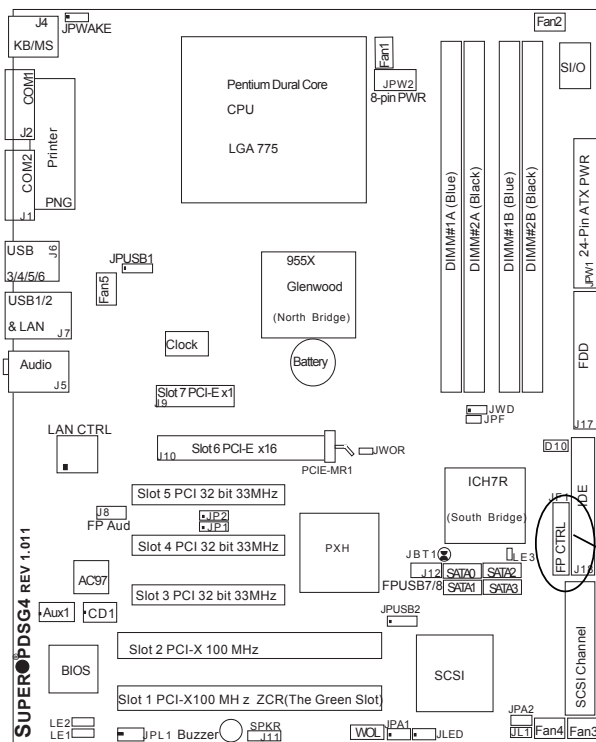

Power Button

The Power Button connection is located on pins 1 and 2 of JF1. Momentarily contacting both pins will power on/off the system. This button can also be configured to function as a suspend button (with a setting in BIOS - see Chapter 4). To turn off the power when set to suspend mode, press the button for at least 4 seconds. Refer to the table on the right for pin definitions.

PWR Button Pin Definitions (JF1)

Pin#	Definition
1	PWR Signal
2	GND

Chassis Intrusion

A Chassis Intrusion header is located at JL1. Attach an appropriate cable to inform you of a chassis intrusion.

Chassis Intrusion Pin Definitions (JL1)

Pin Number	Definition
1	Intrusion Input
2	Ground

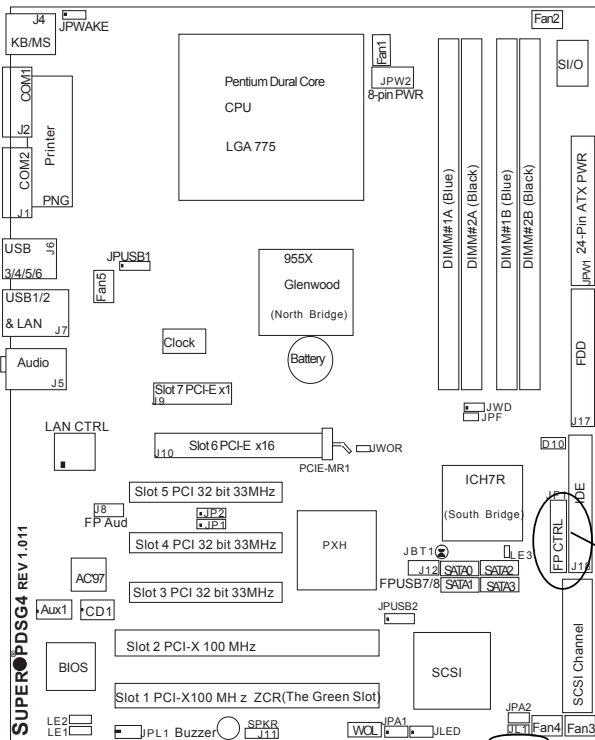

PWR Button

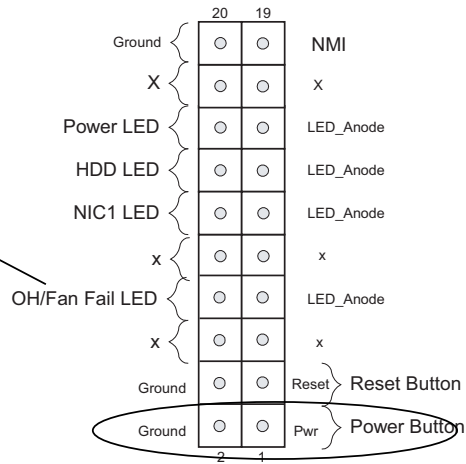

Chassis Intrusion

Serial Ports

Two serial ports are included on the motherboard. COM1/COM2 (J1, J2) is a port located beside the mouse/key-board ports. See the table on the right for pin definitions.

**Serial Port Pin Definitions
(COM1, COM2)**

Pin Number	Definition	Pin Number	Definition
1	CD	6	DSR
2	RD	7	RTS
3	TD	8	CTS
4	DTR	9	RI
5	Ground	10	NC

Note: Pin 10 is included on the header but not on the port.

*NC indicates no connection.

CD Header/Auxiliary Audio Header

A 4-pin CD header (CD1) and an Auxiliary header (Aux1.) are located on the motherboard. These headers allow you to use the onboard sound for audio CD playback. Connect the audio cable from your CD drive to the header that fits your cable's connector. Only one CD header can be used at any one time. See the tables at right for pin definitions.

**Audio CD Header Pin Definitions
(CD In)**

Pin #	Definition
1	Left Stereo Signal
2	Ground
3	Ground
4	Right Stereo Signal

**Auxiliary Header Pin Definitions
(Aux.)**

Pin #	Definition
1	Right Stereo Signal
2	Ground
3	Ground
4	Left Stereo Signal

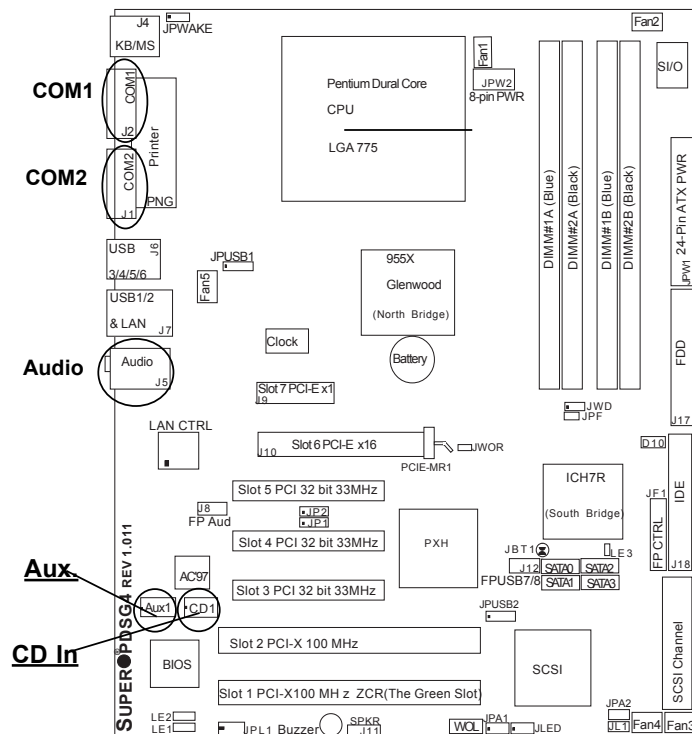

Universal Serial Bus (USB)

There are six Universal Serial Bus ports located at (J7, J6) on the I/O back panel and additional two USB ports located at (J12) on the motherboard. These ports, labeled USB7 to USB8, can be used to provide front side chassis access (cables not included). See the tables on the right for pin definitions.

USB Pin Definition

J6,J7

Pin#	Definition
1	+5V
2	P0-
3	P0+
4	Ground

J12

Pin Number	Definition	Pin Number	Definition
1	+5V	2	+5V
3	PO-	4	PO-
5	PO+	6	PO+
7	Ground	8	Ground
		10	Ground

USB 3-6 USB 0/1

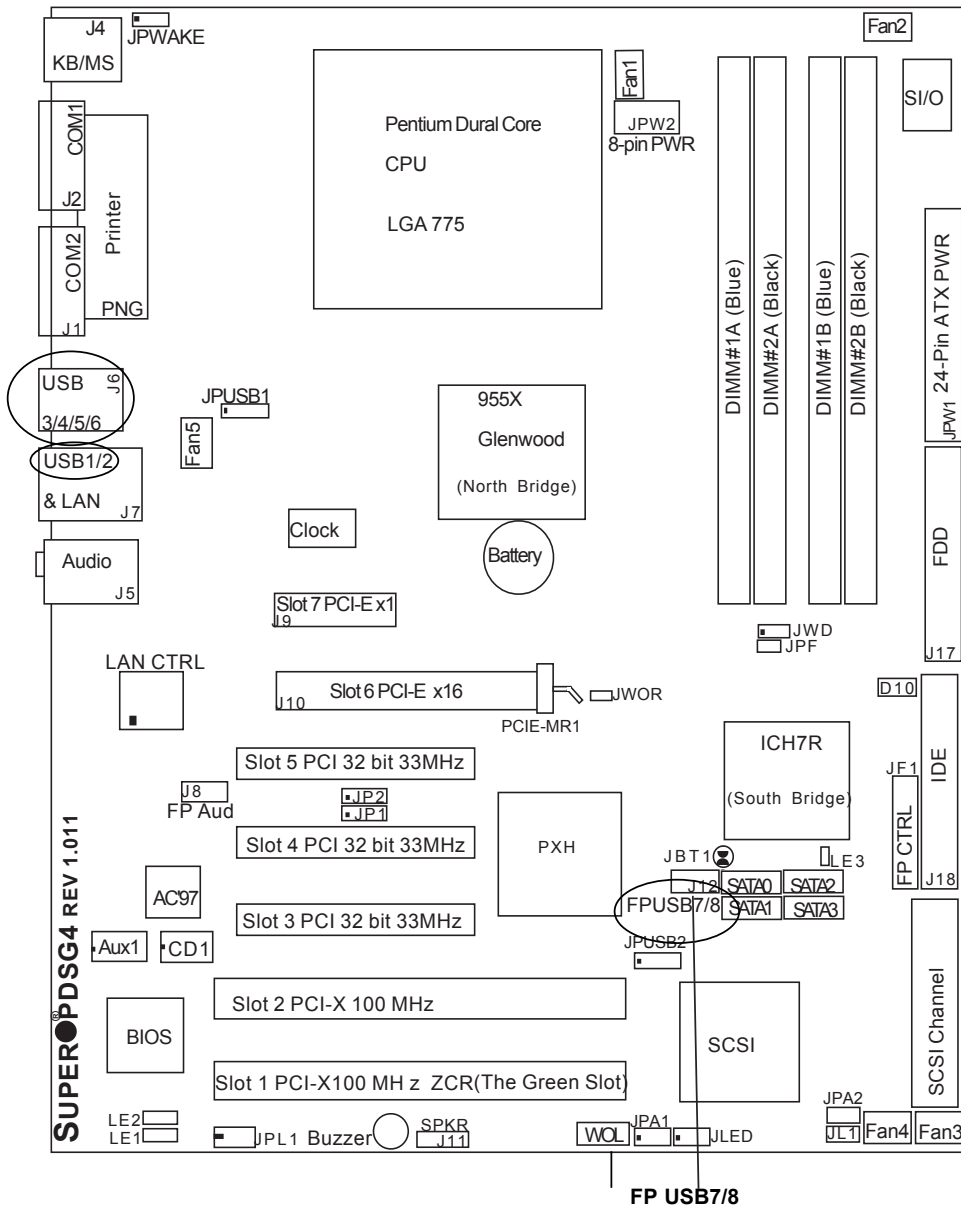

GLAN (Giga-bit Ethernet Ports)



A G-bit Ethernet port (LAN) is located beside the Audio Connector on the IO backplane. This port accepts RJ45 type cables.

ATX PS/2 Keyboard and PS/2 Mouse Ports

The ATX PS/2 keyboard and PS/2 mouse (J4) are located next to the rear USB ports at the corner of the motherboard. See the table at right for pin definitions. (See Figure 2-3 for the locations of each.)

PS/2 Keyboard and Mouse Port Pin Definitions

Pin Number	Definition
1	Data
2	NC
3	Ground
4	VCC
5	Clock
6	NC

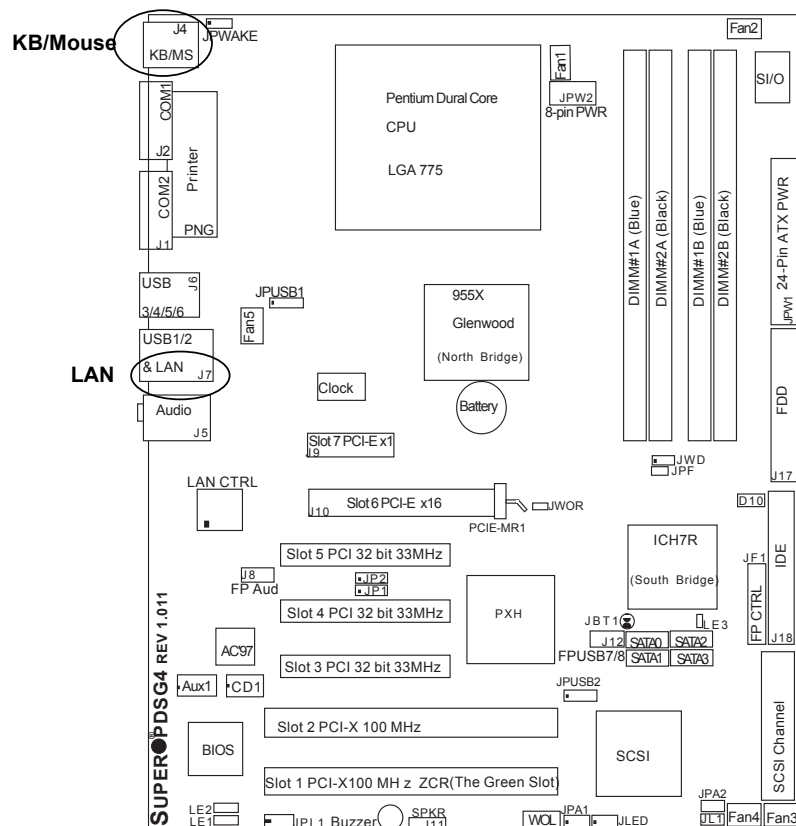

Fan Headers

The PDSG4/PDSGE has five fan headers (Fan1 to Fan5). (***Note:** all these fans are 4-pin fans. However, Pins 1-3 of the fan headers are backward compatible with the traditional 3-pin fans.) See the table on the right for pin definitions. (***The onboard fan speeds are controlled by Thermal Management via BIOS--Hardware Monitor in the Advanced Setting.** Note: Default: Disabled, When using Thermal Management setting, please use all 3-pin fans or all 4-pin fans on the motherboard. Please do not use 3-pin fans and 4-pin fans on the same board.)

4-pin Fan Header Pin Definitions

Pin#	Definition
1	Ground (black)
2	+12V (red)
3	Tachometer
4	PWM_Control

Caution: These fan headers use DC power.

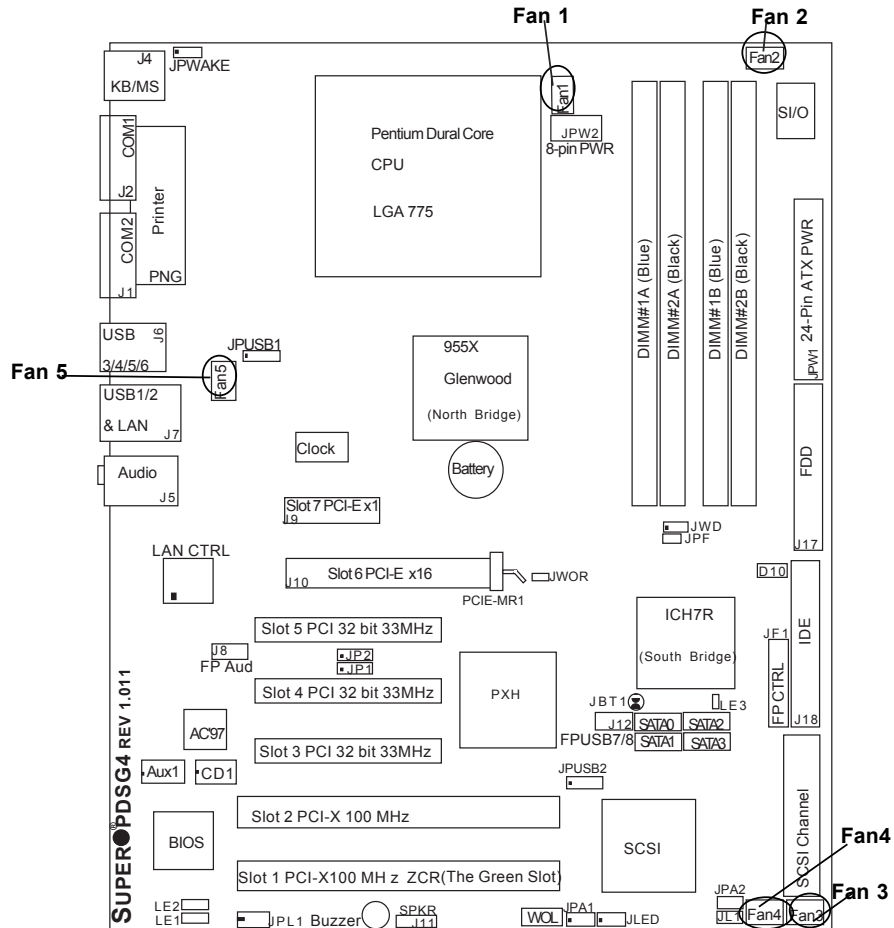

Wake-On-Ring

The Wake-On-Ring header is designated JWOR. This function allows your computer to receive and be awakened by an incoming call to the modem when in suspend state. See the table on the right for pin definitions. You must have a Wake-On-Ring card and cable to use this feature.

**Wake-on-Ring
Pin Definitions
(JWOR)**

Pin Number	Definition
1	Ground
2	Wake-up

Wake-On-LAN

The Wake-On-LAN header is designated WOL. See the table on the right for pin definitions. You must enable the LAN Wake-Up setting in BIOS to use this feature. You must also have a LAN card with a Wake-on-LAN connector and cable.

**Wake-On-LAN Pin
Definitions (WOL)**

Pin Number	Definition
1	+5V Standby
2	Ground
3	Wake-up

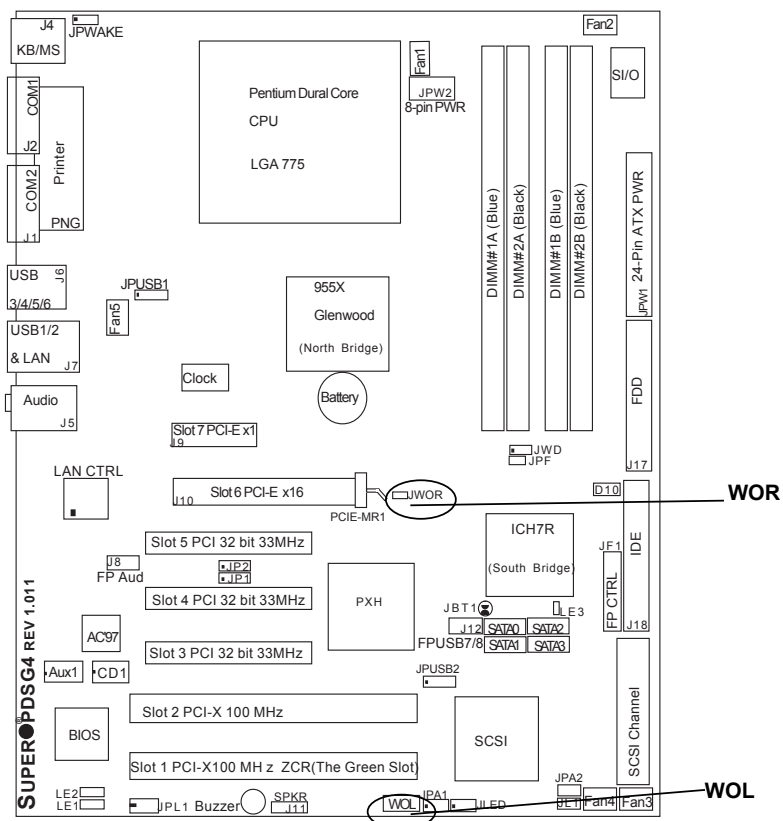

Power LED

The Power LED connector is located at JLED. This connection is used to provide LED Indication of power being supplied to the system. See the table on the right for pin definitions.

**JLED
Pin Definitions**

Pin Number	Definition
1	+5V
2	Key
3	Ground

Front Panel (FP) Audio

When front panel headphones are plugged in, the back panel audio output is disabled. This is done through the FP Audio header (J8). If the front panel interface card is not connected to the front panel audio header, jumpers should be installed on the header (J8) pin pairs: 1-2, 5-6, and 9-10. If these jumpers are not installed, the back panel line out connector will be disabled and microphone input Pin 1 will be left floating, which can lead to excessive back panel microphone noise and cross talk. See the table below for pin definitions.

AC'97 FP Audio Header Signal Names		
Pin#	Signal	Description
1	MIC	FP microphone input signal
2	AUD_GND	Ground used by analog audio circuits
3	MIC_BIAS	Microphone power
4	AUD_VCC	Analog audio VCC+5V
5	FP_OUT_R	Right channel audio signal to front panel (headphone drive capable)
6	FP_RETURN_R	Right channel audio signal return from front panel (when headphones unplugged)
7	NC	NC (*NC=no connection)
8	Key	No pin
9	FP_OUT_L	Left channel audio signal to front panel (headphone drive capable)
10	FP_RETURN_L	Left channel audio signal return from front panel (when headphones unplugged)

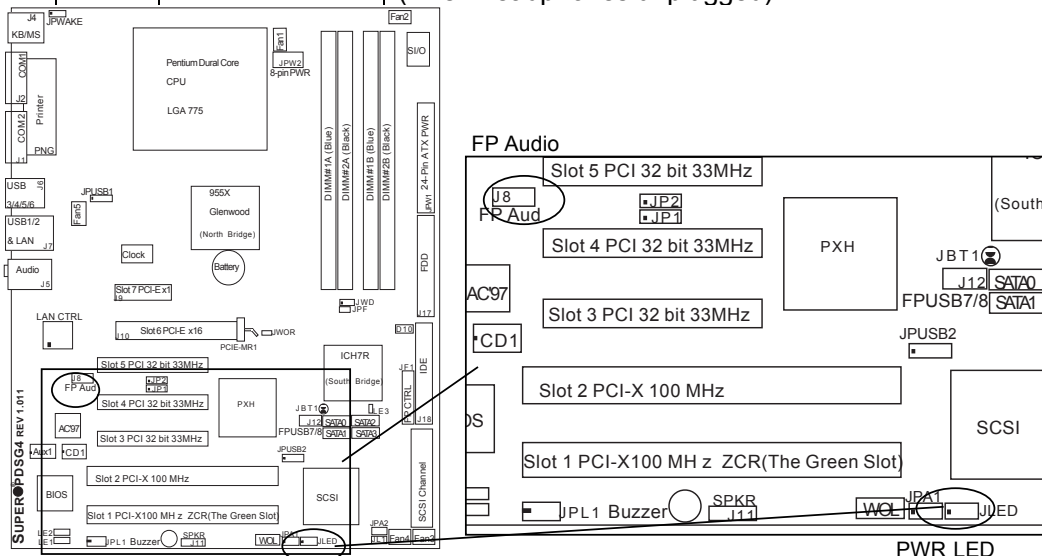

2-7 Jumper Settings

Explanation of Jumpers

To modify the operation of the motherboard, jumpers can be used to choose between optional settings. Jumpers create shorts between two pins to change the function of the connector. Pin 1 is identified with a square solder pad on the printed circuit board. See the motherboard layout pages for jumper locations.

Note: On two pin jumpers, "Closed" means the jumper is on and "Open" means the jumper is off the pins.

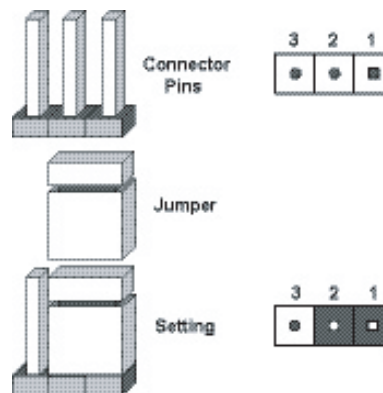

GLAN Enable/Disable

JPL1 enables or disables the GLAN port on the motherboard. See the table on the right for jumper settings. The default setting is enabled.

GLAN Enable/Disable Jumper Settings

Jumper Position	Definition
Pins 1-2	Enabled
Pins 2-3	Disabled

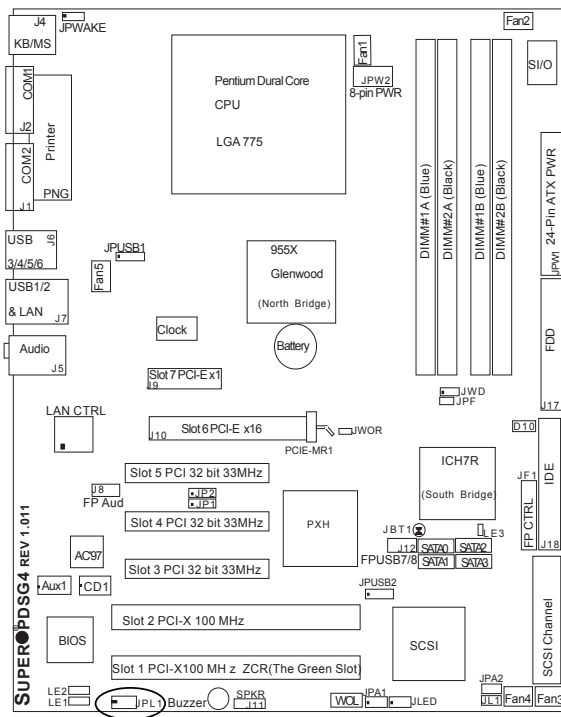

CMOS Clear

JBT1 is used to clear CMOS. Instead of pins, this "jumper" consists of contact pads to prevent the accidental clearing of CMOS. To clear CMOS, use a metal object such as a small screw driver to touch both pads at the same time to short the connection. Always remove the AC power cord from the system before clearing CMOS.

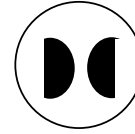

Note: For an ATX power supply, you must completely shut down the system, remove the AC power cord and then short JBT1 to clear CMOS. Do not use the PW ON connector to clear CMOS.

Watch Dog Enable

JWD controls Watch Dog, a system monitor that takes action when a software application freezes the system. Close Pins 1-2 to reset the system if a program hangs. Close Pins 2-3 to generate a non-maskable interrupt for the program that hangs. Watch Dog must also be enabled in BIOS.

Watch Dog Jumper Settings

Jumper Position	Definition
Pins 1-2	WD to Reset
Pins 2-3	WD to NMI
Open	Disabled

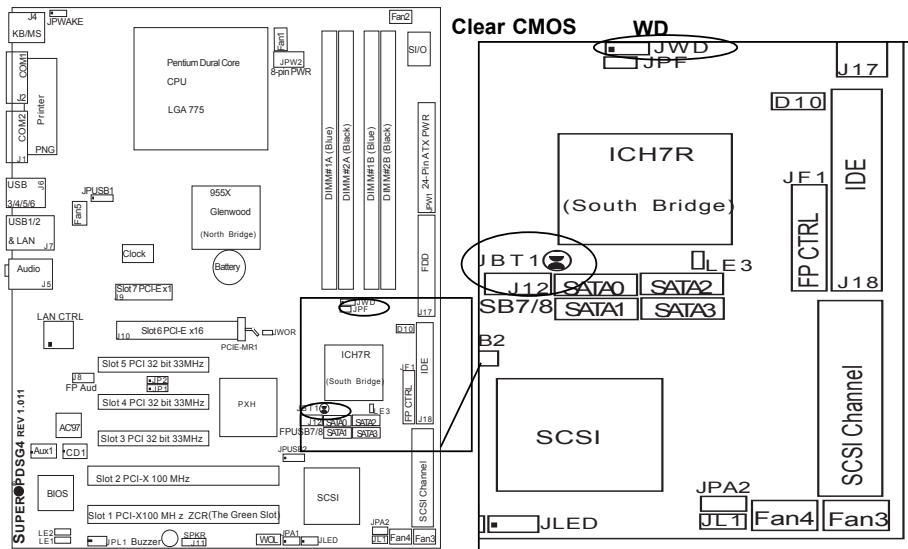

USB Wake-Up

Use JPUSB jumpers to enable the function of "System Wake-Up via USB devices", which allows you to "wake-up" the system by pressing a key on the USB keyboard or by clicking the USB mouse of your system. The JPUSB jumpers are used together with the USB Wake-Up function in the BIOS. Enable both the jumpers and the BIOS setting to allow the system to "wake-up via USB Devices". See the table on the right for jumper settings and jumper connections. (*Note: JPUSB1 is for Back Panel USB ports:1/2/3/4/5/6, and JPUSB2 is for Front Panel USB ports:7/8.)

**USB Wake-Up
Jumper Settings
(JPUSB1/JPUSB2)**

Jumper Position	Definition
1-2	Enabled
2-3	*Disabled

(*Default)

(*Note: The default jumper setting for the USB ports is "Disabled". However, when the "USB Wake-Up" function is enabled in the BIOS and the desired USB ports are enabled via the JPUSB jumper, please be sure to remove all USB devices from the USB ports whose USB jumpers are set to "Disabled" before the system goes into the standby mode.)

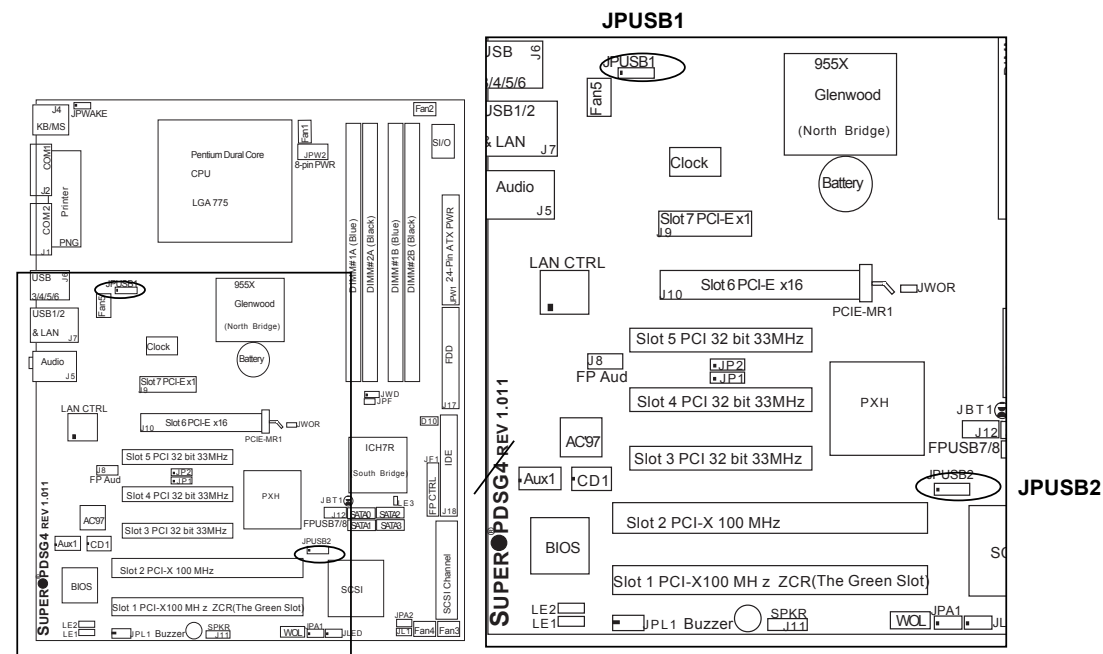

SMBus to PCI/PCI-Exp. Slots

Jumpers JP1, JP2 allow you to connect PCI/PCI-E slots to the System Management Bus. The default setting is "Open" to disable the connection. See the table on the right for jumper settings.

SMBus to PCI/PCI-Exp

Jumper Position	Definition
closed	Enabled
*Open	Disabled

(*Default)

Keyboard Wake-Up

The JPWAKE jumper is used together with the Keyboard Wake-Up function in BIOS. Enable both the jumper and the BIOS setting to allow the system to be woken up when the user hits a key on the keyboard. See the table on the right for jumper settings. Your power supply must meet ATX specification 2.01 or higher and supply 720 mA of standby power to use this feature.

Keyboard Wake-Up Jumper Settings

Jumper Position	Definition
1-2	Enabled
2-3	Disabled

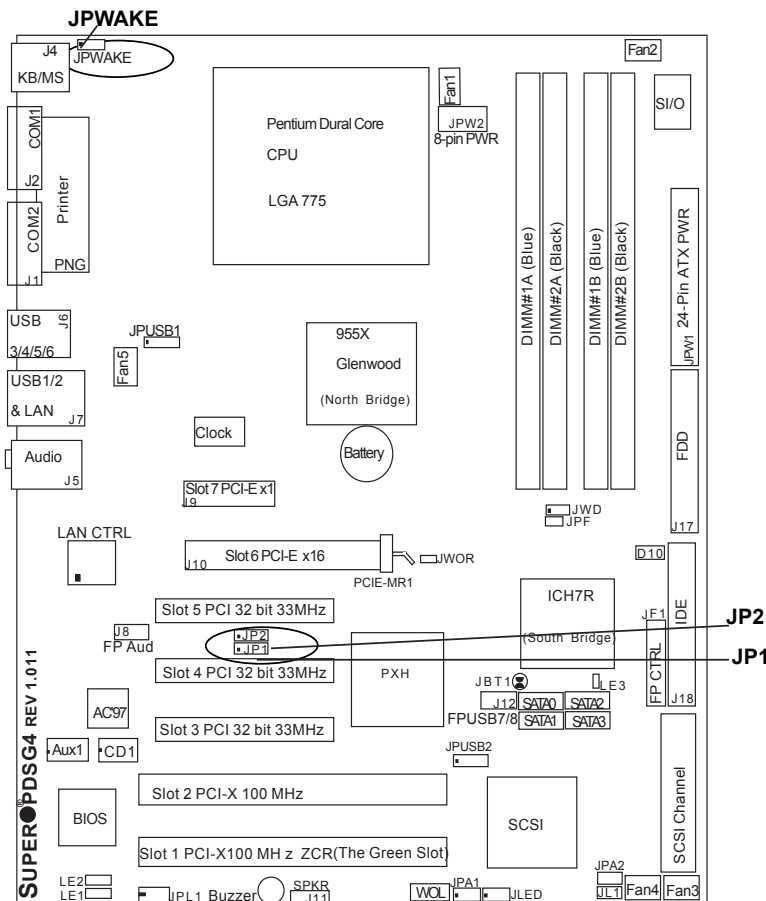

SCSI Enable/Disable (*PDSG4 only)

Jumper JPA1 allows you to enable or disable the SCSI Controller. The default setting is pins 1-2 to enable the SCSI connection. See the table on the right for jumper settings.

SCSI Enable/Disable Jumper Settings

Jumper Position	Definition
Pins 1-2	Enabled
Pins 2-3	Disabled

SCSI Termination Enable/Disable (*PDSG4 only)

Jumpers JPA2 allows you to enable or disable termination for the SCSI connector. The default setting is "open" to enable the SCSI channel. (For SCSI to function properly, please do not change the default setting.) See the table on the right for jumper settings.

SCSI Channel Termination Enable/Disable Jumper Settings

Jumper Position	Definition
*Open	Enabled
Closed	Disabled

(*Default: Open. Please do not change the default setting.)

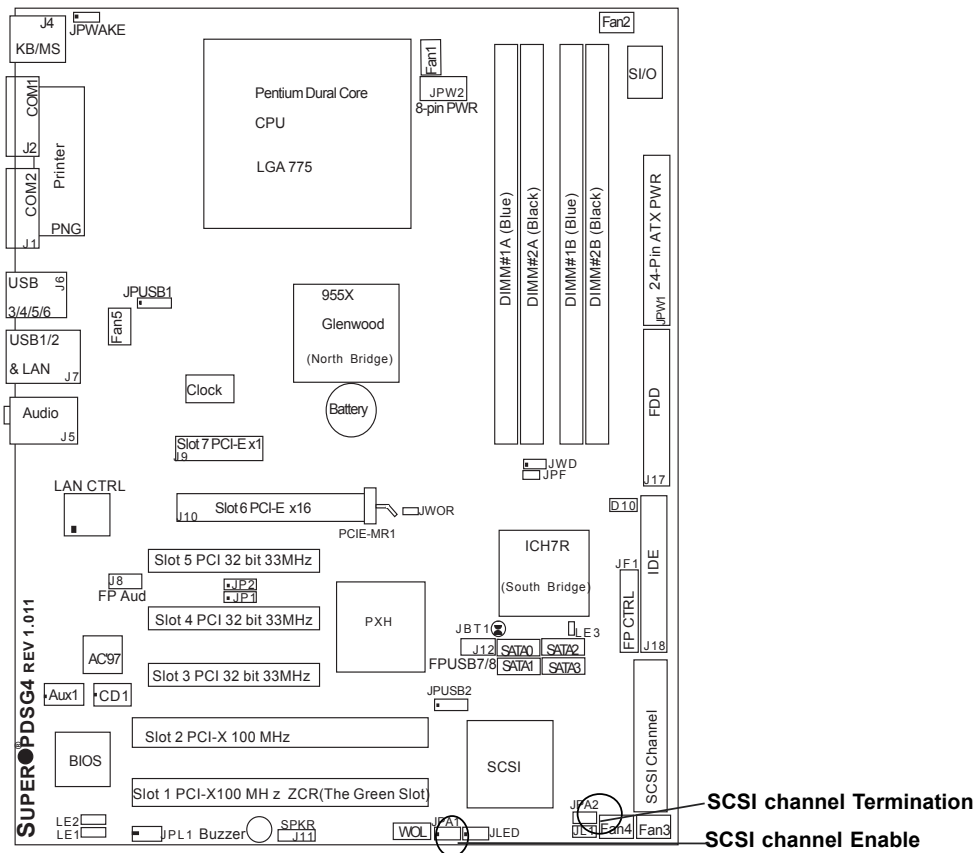

2-8 Onboard Indicators

GLAN LEDs

The Gigabit Ethernet LAN ports (located beside the Video port) has two LEDs. The yellow LED indicates activity while the other LED may be green, orange or off to indicate the speed of the connection. See the table at right for the functions associated with the second LED.



(Rear View: when viewing from the rear side of the chassis)

G-bit LAN Left LED Indicator

LED Color	Definition
Off	10 Mbps
(*Also:Off	No Connection)
Green	100 Mbps
Orange	1 Gbps

1 Gb LAN Right LED Indicator(Activity LED)

LED Color	Definition
Amber	Blinking 10Mbps/ 100Mbps/1Gbps

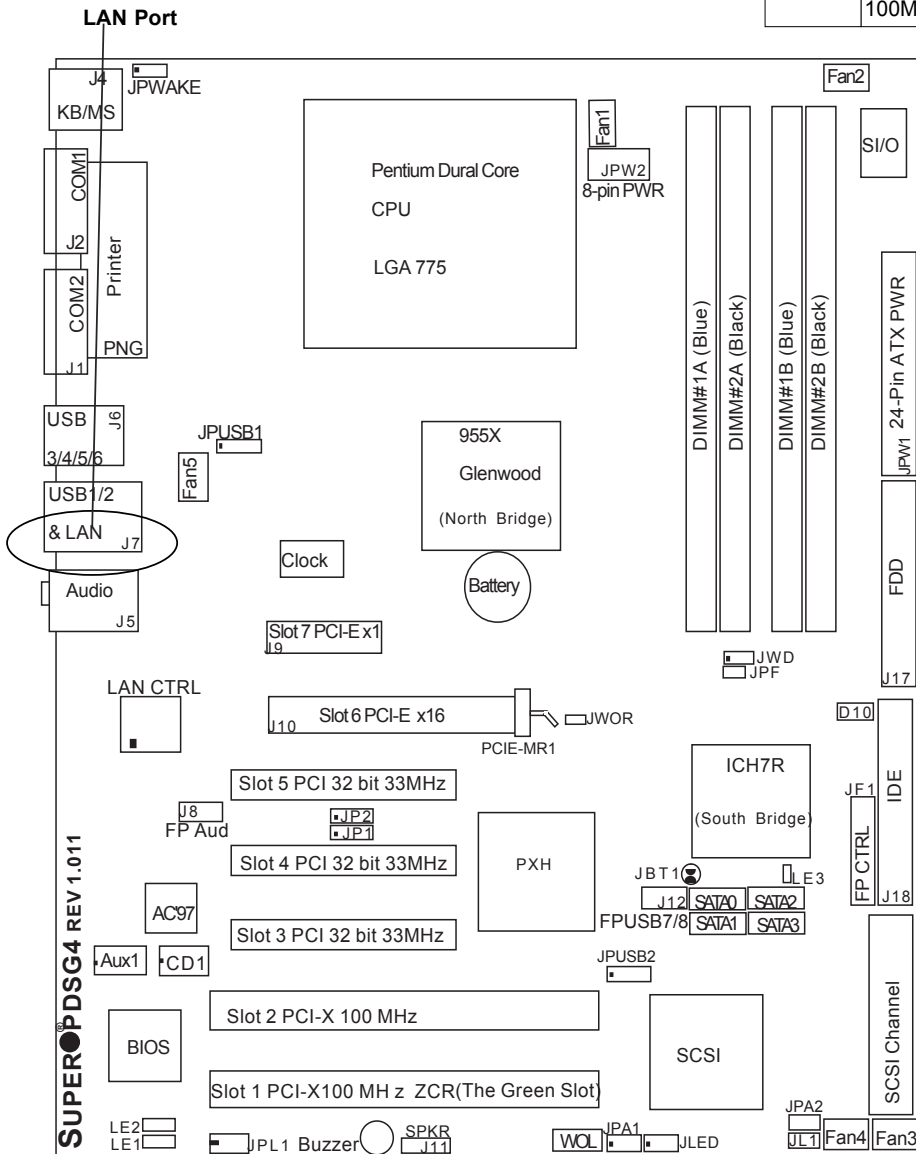

2-9 Parallel Port, Floppy and Hard Disk Drive Connections

Note the following when connecting the floppy and hard disk drive cables:

- A red mark on a wire typically designates the location of pin 1.
- A single floppy disk drive ribbon cable has two connectors to provide for two floppy disk drives. The connector with twisted wires always connects to drive A, and the connector that does not have twisted wires always connects to drive B.

Parallel (Printer) Port Connector

The parallel (printer) port is located above the COM ports. See the table on the right for pin definitions.

Parallel (Printer) Port Pin Definitions

Pin Number	Function	Pin Number	Function
1	Strobe-	2	Auto Feed-
3	Data Bit 0	4	Error-
5	Data Bit 1	6	Init-
7	Data Bit 2	8	SLCT IN-
9	Data Bit 3	10	GND
11	Data Bit 4	12	GND
13	Data Bit 5	14	GND
15	Data Bit 6	16	GND
17	Data Bit 7	18	GND
19	ACK	20	GND
21	BUSY	22	GND
23	PE	24	GND
25	SLCT	26	NC

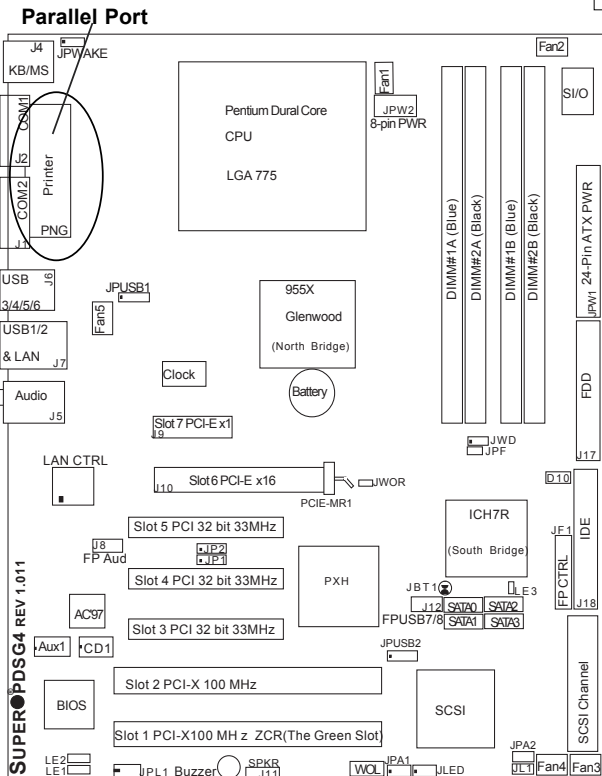

Floppy Connector

The floppy connector is located at J17. See the table below for pin definitions.

Floppy Connector Pin Definitions

Pin Number	Function	Pin Number	Function
1	GND	2	FDHDIN
3	GND	4	Reserved
5	Key	6	FDEDIN
7	GND	8	Index-
9	GND	10	Motor Enable
11	GND	12	Drive Select B-
13	GND	14	Drive Select A-
15	GND	16	Motor Enable
17	GND	18	DIR-
19	GND	20	STEP-
21	GND	22	Write Data-
23	GND	24	Write Gate-
25	GND	26	Track 00-
27	GND	28	Write Protect-
29	GND	30	Read Data-
31	GND	32	Side 1 Select-
33	GND	34	Diskette

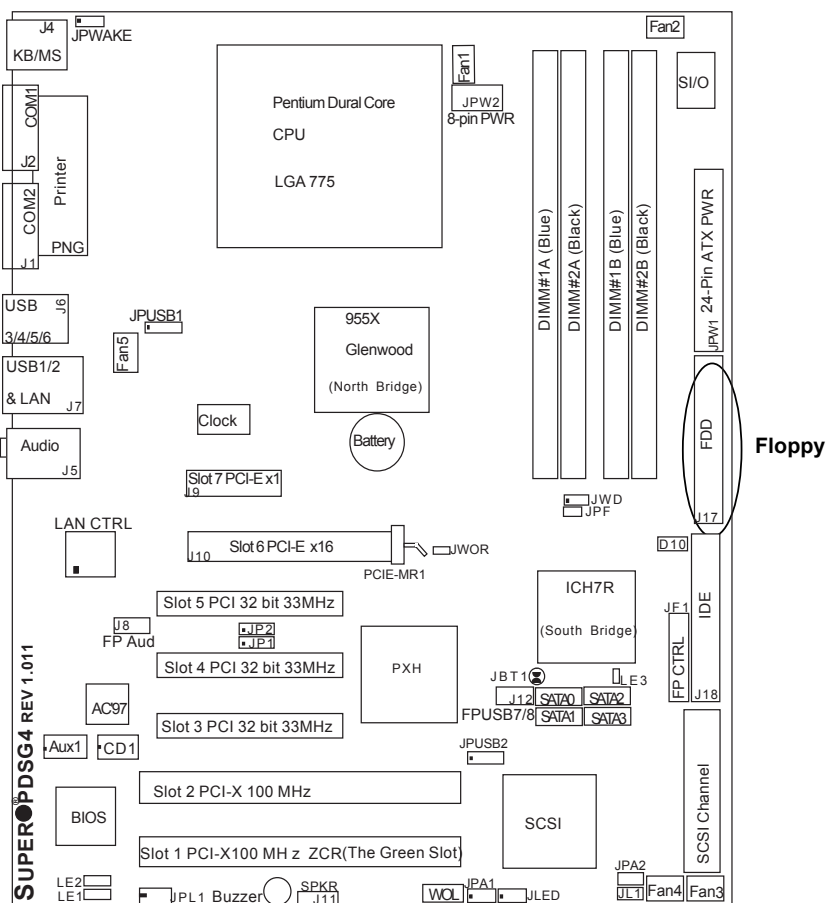

IDE Connector

An IDE Connector is located at J18 on the motherboard. See the table on the right for pin definitions.

IDE Connector Pin Definitions

Pin Number	Function	Pin Number	Function
1	Reset IDE	2	GND
3	Host Data 7	4	Host Data 8
5	Host Data 6	6	Host Data 9
7	Host Data 5	8	Host Data 10
9	Host Data 4	10	Host Data 11
11	Host Data 3	12	Host Data 12
13	Host Data 2	14	Host Data 13
15	Host Data 1	16	Host Data 14
17	Host Data 0	18	Host Data 15
19	GND	20	Key
21	DRQ3	22	GND
23	I/O Write-	24	GND
25	I/O Read-	26	GND
27	IOCHRDY	28	BALE
29	DACK3-	30	GND
31	IRQ14	32	IOCS16-
33	Addr 1	34	GND
35	Addr 0	36	Addr 2
37	Chip Select 0	38	Chip Select 1-
39	Activity	40	GND

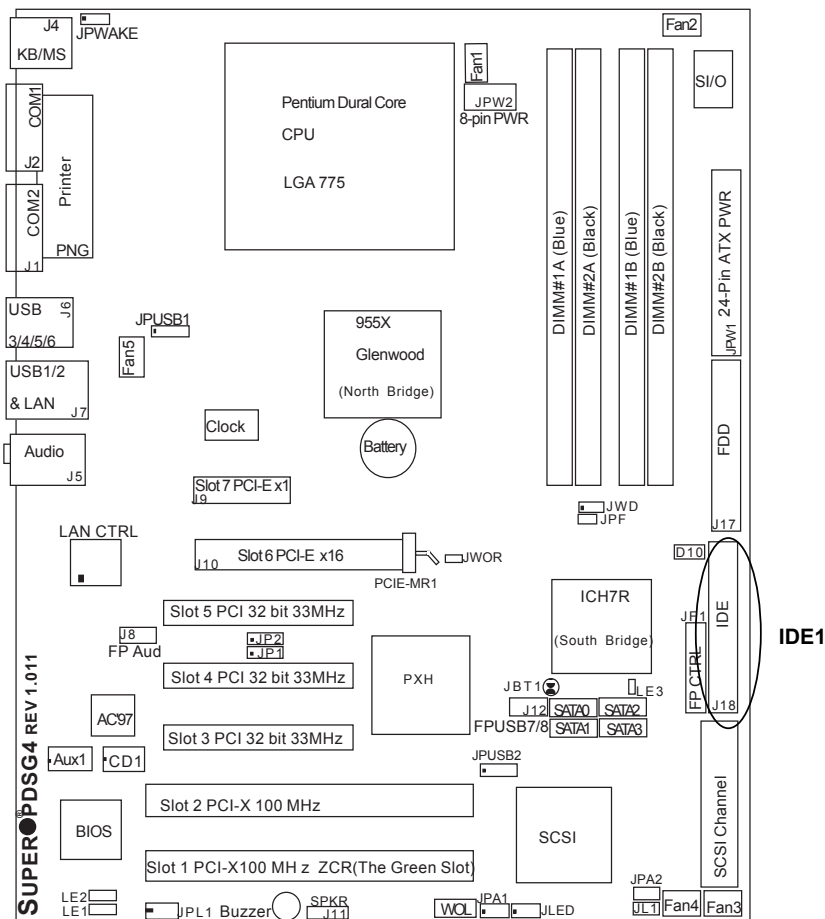

Ultra 320 SCSI Connectors (*PDSG4 only)

Refer to the table below for the pin definitions of the Ultra 320 SCSI connector located at JA3.

68-pin Ultra320 SCSI Connector

Connector Contact Number	Signal Names	Connector Contact Number	Signal Names
1	+DB(12)	35	-DB(12)
2	+DB(13)	36	-DB(13)
3	+DB(14)	37	-DB(14)
4	+DB(15)	38	-DB(15)
5	+DB(P1)	39	-DB(P1)
6	+DB(0)	40	-DB(0)
7	+DB(1)	41	-DB(1)
8	+DB(2)	42	-DB(2)
9	+DB(3)	43	-DB(3)
10	+DB(4)	44	-DB(4)
11	+DB(5)	45	-DB(5)
12	+DB(6)	46	-DB(6)
13	+DB(7)	47	-DB(7)
14	+DB(P)	48	-DB(P)
15	GROUND	49	GROUND
16	DIFFSENS	50	GROUND
17	TERMPWR	51	TERMPWR
18	TERMPWR	52	TERMPWR
19	RESERVED	53	RESERVED
20	GROUND	54	GROUND
21	+ATN	55	-ATN
22	GROUND	56	GROUND
23	+BSY	57	-BSY
24	+ACK	58	-ACK
25	+RST	59	-RST
26	+MSG	60	-MSG
27	+SEL	61	-SEL
28	+C/D	62	-C/D
29	+REQ	63	-REQ
30	+I/O	64	-I/O
31	+DB(8)	65	-DB(8)
32	+DB(9)	66	-DB(9)
33	+DB(10)	67	-DB(10)
34	+DB(11)	68	-DB(11)

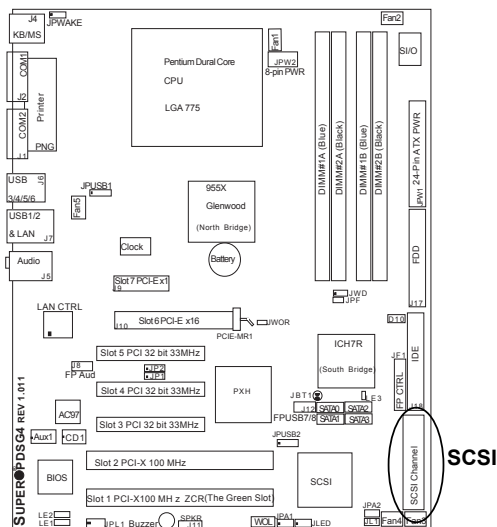

Chapter 3

Troubleshooting

3-1 Troubleshooting Procedures

Use the following procedures to troubleshoot your system. If you have followed all of the procedures below and still need assistance, refer to the 'Technical Support Procedures' and/or 'Returning Merchandise for Service' section(s) in this chapter. Always disconnect the AC power cord before adding, changing or installing any hardware components.

Before Power On

1. Make sure that the +5v standby LED is not lit (LE Indicators on the motherboard).
2. Make sure that the 8-pin 12v power connector at JPW2 is connected to your power supply.
3. Make sure that there are no short circuits between the motherboard and chassis.
4. Disconnect all ribbon/wire cables from the motherboard, including those for the keyboard and mouse.
5. Remove all add-on cards.
6. Install a CPU and heatsink (Be sure that it is fully seated,) and then, connect the chassis speaker and the power LED to the motherboard. Check all jumper settings as well.
7. It is imperative that you use the correct type of CMOS battery as specified by the Manufacturer. Do not install the CMOS battery upside down to avoid possible explosion.

No Power

1. Make sure that there are no short circuits between the motherboard and the chassis.
2. Make sure that all jumpers are set to their default positions.
3. Check if the 115V/230V switch on the power supply is properly set.
4. Turn the power switch on and off to test the system.
5. The battery on your motherboard may be old. Check to verify that it still supplies ~3VDC. If it does not, replace it with a new one.

No Video

1. If the power is on, but you have no video--in this case, you will need to remove all the add-on cards and cables first.
 2. Use the speaker to determine if any beep codes exist. (Refer to Appendix A for details on beep codes.)
-

NOTE

If you are a system integrator, VAR or OEM, a POST diagnostics card is recommended. For I/O port 80h codes, refer to App. B.

Memory Errors

1. Make sure that the DIMM modules are properly installed and fully seated in the slots.
2. You should be using unbuffered, ECC DDR 2-677/533 memory (see the next page). Also, it is recommended that you use the same memory speed for all DIMMs in the system. See Section 2-4 for memory limitations.
3. Check for bad DIMM modules or slots by swapping modules between slots and noting the results.
4. Check the power supply voltage 115V/230V switch.

Losing the System's Setup Configuration

1. Please be sure to use a high quality power supply. A poor quality power supply may cause the system to lose the CMOS setup information. Refer to Section 1-6 for details on recommended power supplies.
2. The battery on your motherboard may be old. Check to verify that it still supplies ~3VDC. If it does not, replace it with a new one.
3. If the above steps do not fix the Setup Configuration problem, contact your vendor for repairs.

3-2 Technical Support Procedures

Before contacting Technical Support, please make sure that you have followed all the steps listed below. Also, note that as a motherboard manufacturer, Supermicro does not sell directly to end-users, so it is best to first check with your distributor or reseller for troubleshooting services. They should know of any possible problem(s) with the specific system configuration that was sold to you.

1. Please go through the 'Troubleshooting Procedures' and 'Frequently Asked Question' (FAQ) sections in this chapter or see the FAQs on our web site (<http://www.supermicro.com/support/faqs/>) before contacting Technical Support.
2. BIOS upgrades can be downloaded from our web site at (<http://www.supermicro.com/support/bios/>).

Note: Not all BIOS can be flashed; some can be flashed, depending on the modifications to the boot block code.

3. If you've followed the instructions above to troubleshoot your system, and still cannot resolve the problem, then please contact Supermicro's technical support and provide them with the following information:

- Motherboard model and PCB revision number
- BIOS release date/version (this can be seen on the initial display when your system first boots up)
- System configuration

An example of a Technical Support form is on our web site at (<http://www.supermicro.com/support/contact.cfm>).

4. Distributors: For immediate assistance, please have your account number ready when placing a call to our technical support department. We can be reached by e-mail at support@supermicro.com, by phone at:

(408) 503-8000, option 2, or by fax at (408)503-8019.

3-3 Frequently Asked Questions

Question: What type of memory does my motherboard support?

Answer: The PDSG4/PDSGE supports up to 8 GB of **unbuffered**, ECC, DDR2-677/533/400, two-way interleaved or non-interleaved SDRAM. See Section 2-4 for details on installing memory.

Question: Why does Microsoft Windows XP (SP2) and Windows Vista show less memory than what is physically installed?

Answer: Microsoft implemented a design change in Windows XP with Service Pack 2 (SP2) and Windows Vista. This change is specific to the Physical Address Extension (PAE) mode behavior which improves driver compatibility. For more information, please read the following article at Microsoft's Knowledge Base website at: <http://support.microsoft.com/kb/888137>.

Question: How do I update my BIOS?

Answer: It is recommended that you **do not** upgrade your BIOS if you are not experiencing any problems with your system. Updated BIOS files are located on our web site at <http://www.supermicro.com/support/bios/>. Please check our BIOS warning message and the information on how to update your BIOS on our web site. Select your motherboard model and download the BIOS file to your computer. Also, check the current BIOS revision and make sure that it is newer than your BIOS before downloading. You can choose from the zip file and the .exe file. If you choose the zip BIOS file, please unzip the BIOS file onto a bootable device or a USB pen. Run the batch file using the format flash.bat filename.rom from your bootable device or USB pen to flash the BIOS. Then, your system will automati-

cally reboot. If you choose the .exe file, please run the .exe file under Windows to create the BIOS flash floppy disk. Insert the floppy disk into the system you wish to flash the BIOS. Then, bootup the system to the floppy disk. The BIOS utility will automatically flash the BIOS without any prompts. Please note that this process may take a few minutes to complete. Do not be concerned if the screen is paused for a few minutes.



(***Warning**: Do not shut down or reset the system while updating BIOS to prevent possible system boot failure!)

Question: What's on the CD that came with my motherboard?

Answer: The supplied compact disc has quite a few drivers and programs that will greatly enhance your system. We recommend that you review the CD and install the applications you need. Applications on the CD include chipset drivers for the Windows OS, security and audio drivers.

Question: Why can't I turn off the power using the momentary power on/off switch?

Answer: The instant power off function is controlled in the BIOS by the Power Button Mode setting. When the On/Off feature is enabled, the motherboard will have instant off capabilities as long as the BIOS has control of the system. When the Standby or Suspend feature is enabled or when the BIOS is not in control such as during memory count (the first screen that appears when the system is turned on), the momentary on/off switch must be held for more than four seconds to shut down the system. This feature is required to implement the ACPI features on the motherboard.

Question: How do I utilize the six-channel sound?

Answer: The six-channel sound available on the PDSG4/PDSGE can be enabled with the audio driver software that was included in your motherboard package. When activated, sound will be routed through the jacks under the Game Port as follows: Line Out = front L&R speakers, Line In = rear L&R speakers, MIC = center and subwoofer speakers. You must also enable the "AC97 Audio" setting in the Advanced Chipset section of the BIOS setup.

Question: I installed my microphone correctly but I can't record any sound. What should I do?

Answer: Go to <Start>, <Programs>, <Accessories>, <Entertainment> and then <Volume Control>. Under the Properties tab, scroll down the list of devices in the menu and check the box beside "Microphone".

Question: How do I connect the ATA100/66 cable to my IDE device(s)?

Answer: The 80-wire/40-pin high-density ATA100/66 IDE cable that came with your system has two connectors to support two drives. This special cable must be

used to take advantage of the speed the ATA100/66 technology offers. **Connect the blue connector to the onboard IDE header and the other connector(s) to your hard drive(s).** Consult the documentation that came with your disk drive for details on actual jumper locations and settings.

3-4 Returning Merchandise for Service

A receipt or copy of your invoice marked with the date of purchase is required before any warranty service will be rendered. You can obtain service by calling your vendor for a Returned Merchandise Authorization (RMA) number. When returning to the manufacturer, the RMA number should be prominently displayed on the outside of the shipping carton, and mailed prepaid or hand-carried. Shipping and handling charges will be applied for all orders that must be mailed when service is complete.

This warranty only covers normal consumer use and does not cover damages incurred in shipping or from failure due to the alteration, misuse, abuse or improper maintenance of products.

During the warranty period, contact your distributor first for any product problems.

Notes

Chapter 4

BIOS

4-1 Introduction

This chapter describes the Award BIOS for the PDSG4/PDSGE. The Award ROM BIOS is stored in a Flash chip and can be easily upgraded using a floppy disk-based program.

(***Note:** Due to periodic changes to the BIOS, some settings may have been added or deleted and might not yet be recorded in this manual. Refer to the Manual Download area of our web site for any changes to the Award BIOS not reflected in this manual.)

System BIOS

The BIOS is the Basic Input Output System used in all IBM® PC, XT™, AT®, and PS/2® compatible computers. The Award BIOS Flash chip stores the system parameters, such as amount of memory, type of disk drives and video displays, etc. CMOS requires very little power. When the computer is turned off, a back-up battery provides power to the BIOS Flash chip, enabling it to retain the system parameters. Each time the computer is powered-on, the computer is then configured with the values stored in the BIOS ROM by the system BIOS, which gains control when the computer is powered on.

How To Change the Configuration Data

The CMOS information that determines the system parameters may be changed by entering the BIOS Setup utility. This Setup utility can be accessed by pressing at the appropriate time during system boot.

Starting the Setup Utility

Normally, the only visible POST (Power On Self Test) routine is the memory test. As the memory is being tested, press the <Delete> key to enter the main menu of the BIOS Setup utility. From the main menu, you can access the other setup screens, such as the Chipset and Power menus. Section 4-3 gives detailed descriptions of each parameter setting in the Setup utility.



Warning: Do not shut down or reset the system while updating the BIOS to prevent possible system boot failure!

4-2 Running Setup

**Optimal default settings are in bold text unless otherwise noted.*

The BIOS setup options described in this section are selected by choosing the appropriate text from the Main BIOS Setup screen. All displayed text is described in this section, although the screen display is often all you need to understand how to set options (see next page).

When you first power on the computer, the AwardBIOS™ is immediately activated.

While the BIOS is in control, the Setup program can be activated in one of two ways:

1. By pressing immediately after turning the system on, or
2. When the following message appears briefly at the bottom of the screen during the POST (Power On Self-Test), press the key to activate the Main Setup Menu.

(*Note: Press DEL to enter SETUP)

4-3 Main BIOS Setup

All Main Setup options are described in this section. The Main BIOS Setup screen is displayed below.

Use the <Up> <Down> arrow keys or the <Tab> key to move among the different settings in the above menu.

Press the <Esc> key to exit the CMOS Setup Menu and use the <Left> <Right> arrow keys to enter the other categories of BIOS settings. The next section is described in detail to illustrate how to navigate through the menus.

Main BIOS Setup Menu

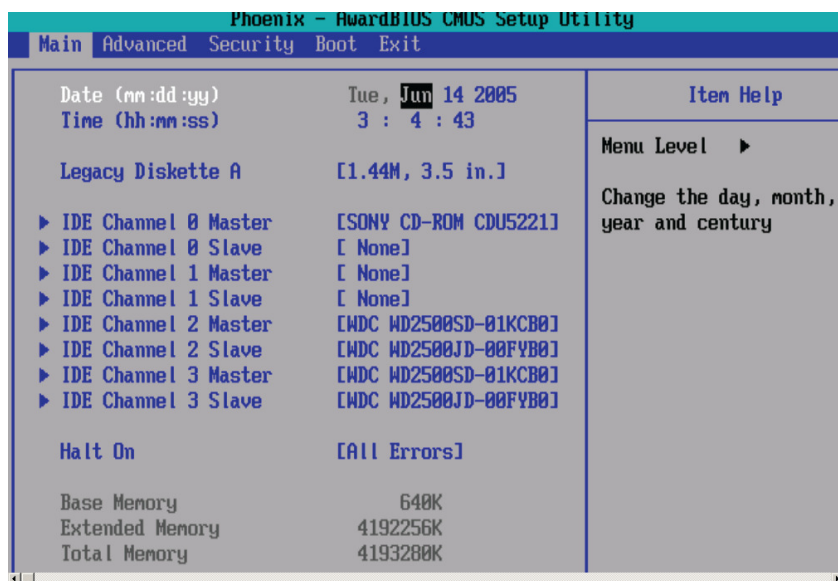

Date/Time

This setting allows the user to the system date and time. Key in the correct information in the mm, dd and yy fields. Press the Enter key to save the data.

Legacy Diskette A

This setting allows the user to set the type of floppy disk drive installed as diskette A. The options are None, 360Kb 5.25 in, 1.2MB 5.25 in, 720Kb 3.5 in, **1.44/1.25MB**, 3.5 in and 2.88MB 3.5 in.

► IDE Channel 0 Master/Slave, IDE Channel 1 Master/Slave, IDE Channel 2 Master/Slave, IDE Channel 3 Master/Slave

These settings allow the user to set the parameters of the IDE Channels 0-1 Master/Slave slots. Hit <Enter> to activate the following sub-menu screen for detailed options. Be sure to set the correct configurations accordingly. The items included in the submenu are listed below:

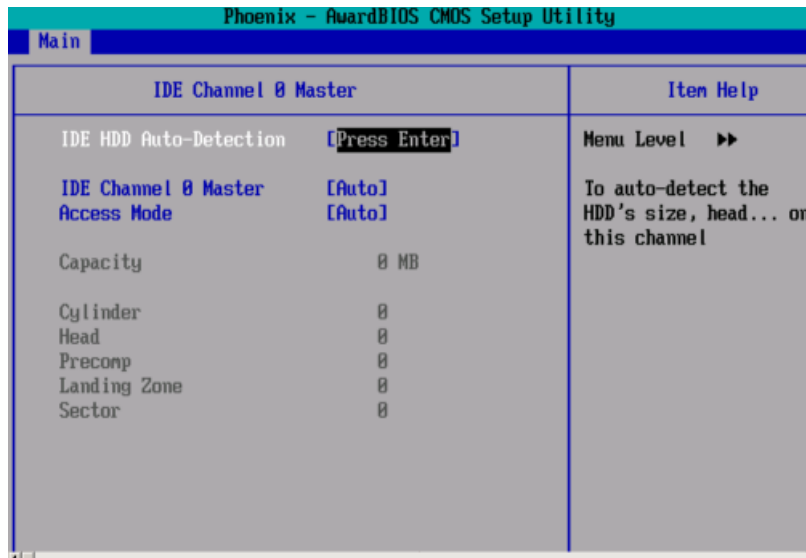

IDE HDD Auto-Detection

This option allows the user to determine the manner in which the Award BIOS sets the settings for the IDE Channels 0-1 Master Devices. The options are None, **Auto** and Manual.

IDE Channels 0 Master

Press the <Enter> key to activate the IDE HDD Auto-Detection function, which will allow the BIOS to automatically detect the status of the IDE HDD installed in the system, such as size, number of cylinders, and the configurations of items such as Head, Precomp, Landing Zone and Sector.

Access Mode

This item allows the user to select the location through which the Award BIOS accesses the IDE Primary Master Device. The settings are CHS, LBA, Large, and **Auto**.

Halt On

This item sets the condition that activates the function of Halt On. The options are **All Error**, No Error, All But Keyboard, All, But Diskette, and All, But Disk/Key.

Base Memory/Extended Memory/Total Memory

These are displays that inform you how much of each type of memory is recognized as being present in the system.

4-4 Advanced BIOS Setup

Choose Advanced BIOS Setup from the Award BIOS main menu with the Left/Right arrow keys. You should see the following display. Select one of the items in the left frame of the screen to go to the sub screen for that item. Advanced BIOS Setup options are displayed by highlighting the option using the arrow keys. All Advanced BIOS Setup options are described in this section.

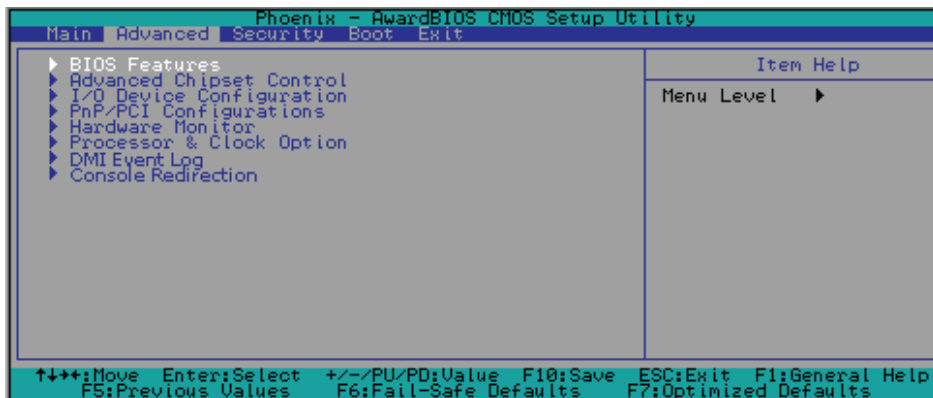

4-4.1 Advanced BIOS Features

When the item of Advanced BIOS Features is highlighted, press the <Enter> key to display the following items:

Quick Boot

If enabled, this feature allows the system to skip certain tests during bootup. This will decrease the time needed to boot the system. The settings are **Enabled** and Disabled.

Quiet Boot

This feature allows the user to activate the function of Quiet Boot. The options are **Enabled** and Disabled.

ACPI Function

Select Enabled to activate the BIOS Support for Advanced Configuration and Power Interface features. The settings are **Enabled** or Disabled.

ACPI Suspend Type

If enabled, the option allows the user to select the ACPI Suspend type. The options are **S1(POS)**, S3(STR), S1&S3.

MPS Version Control

This setting allows you to set the MPS version for your operating system. The options are 1.1 and **1.4**.

Watch Dog Timer Select

This setting allows the user to enable and to set Watch Dog Timer. The options are **Disabled**, 10 Seconds, 20 Seconds, 30 Seconds, 40 Seconds, 1 Minute, 2 Minutes and 4 Minutes.

4-4.2 Advanced Chipset Control



Warning: Take caution when changing the Advanced Chipset settings. An incorrect setting, a very high DRAM frequency, or an incorrect timing may cause the system to become unstable. When this occurs, reset the setting to the default setting.

DRAM Timing Select

This setting allows you to set the Timing for DRAM slots. The options are Manual and **By SPD**.

DRAM Data Integrity Mode

This setting allows you to set the Data Integrity Mode for DRAM slots. The options are Non-ECC, and **ECC**.

PEG Force X1

Enable this option to force the PCI-E x16 slot to function as a PCI-E x1 slot. The options are **Disabled** and Enabled.

SATA Mode

This setting allows you to select the serial ATA Mode for the system. The options are **IDE**, RAID, and AHCI.

On-Chip Serial ATA

Select Disabled to disable the SATA Controller. Select **Auto** to allow the BIOS to make arrangements automatically. Select Combined Mode to use the PATA and SATA Combined Mode. The maximum of 2 IDE drives in each channel is allowed. Select **Enhanced** Mode to enable both SATA and PATA. This mode will support up to 6 IDE drives. Select **SATA Only** to allow SATA to operate in Legacy Mode.

PATA IDE Mode

This feature allows you to select the channel for the PATA IDE mode. The options are **Primary** and Secondary.

SATA Port

This feature allows you to set the mode for SATA ports. The default setting is "**P1, P3 is Secondary.**"

AC97 Auto Select

This feature allows the user to select AC97 functions. The options are **Auto**, AC97 Audio Only, AC97 Modem Only, AC97 Audio and Modem and All Disabled.

USB Controller

This setting allows you to enable or disable the USB Controller. The options are **Enabled**, and Disabled.

USB 2.0 Controller

This setting allows you to enable or disable USB 2.0 (EHCI) Controller. The options are **Enabled** and Disabled.

USB Legacy Support

This setting allows you to enable or disable the functions of USB, Keyboard/Mouse under POST and DOS. The options are **Disabled** and Enabled.

USB KB Wake-up From S3 (S4)

If enabled, the function of Suspend to RAM will be activated to allow the system store Data in RAM and when there is a system crash, the user will be able to "wake up" the system via a USB Keyboard. The options are **Disabled** and Enabled.

4-4.3 I/O Device Configuration**KBC Input Clock**

This setting allows you to configure the KBC Input Clock Settings. The options are 6 MHz, 8 MHz, **12 MHz** and 16 MHz.

Onboard FDC Controller

This setting allows you to set the onboard Floppy Disk Controller. The options are Disabled and **Enabled**.

Onboard Serial Port1/Onboard Serial Port2

This setting allows the user to set the address and the corresponding IRQ for the Serial Port1 and Serial Port 2. The options are Disabled , 3F8/IRQ4, 2F8/IRQ3, 3E8/IRQ4, 2E8/IRQ3, and Auto. The default setting for Serial Port1 is **3F8/IRQ4** and the default setting for Port 2 is **2F8/IRQ3**.

Onboard Parallel Port

This setting allows the user to set the address and the corresponding IRQ for the onboard parallel port. The options are Disabled, **378/IRQ7**, 278/IRQ5 and 3BC/IRQ7.

Parallel Port Mode

This setting sets the mode for the onboard Parallel port. The options are **SPP**, EPP, ECP, ECP+EPP and Normal.

PWRON After PWR-Fail

This setting allows the user to specify how the system will respond when power is reapplied after the system has gone down due to a power failure. The options are **Off**, On and Former-Sts.

Power On Function

This setting allows the user to decide which method to use to power on the system. The options are Password, Hot Key, Mouse Left, Mouse Right, Any Key, **Button Only** and Keyboard 98.

KB Power On Password

This setting allows the user to enter a password to power on the system. Key in a password and press <Enter>.

4-4.4 PCI/PnP Configuration

Choose PCI/PnP Configurations from the Award BIOS main menu with the Left/Right arrow keys. You should see the following items displayed:

Onboard LAN Boot ROM

Select Enable to boot from LAN. The options are **Disabled** and Enable.

Initial Display First

This feature sets the device that will initiate the monitor display when the system is first turned on. The options are **PCI Slot** and PCIEx(press).

Reset Configuration Data

Enabling this setting resets the extended system configuration data when you exit setup. Do this when you have installed a new add-on and the system reconfiguration has caused such a serious conflict that the OS cannot reboot the system. The options are Enabled and **Disabled**.

Resources Controlled By

This setting allows the BIOS to automatically configure all boot and Plug and Play compatible devices. If you choose Auto, you cannot select the IRQ, DMA and memory base address fields, because the BIOS automatically assigns them. The options are **Auto (ESCD)** and Manual.

PCI Optional ROM

Set to Enabled to allocate BIOS resource for the use of a selected PCI slot. The options are: **Enabled** and Disabled.

PCI-X Slot Frequency

This setting allows the user to set PCI- slot frequency. The options are: PCI-33 (MHz), PCI-66 (MHz), PCIX-66 (MHz), PCIX-100 (MHz), and PCIX-133 (MHz).

► PCI Express Root Related Items

Maximum Payload Size

This setting allows the BIOS to set the maximum TLP Payload size for the PCI Express devices in the system. The options are: 128 (bytes), 256 (bytes), 512 (bytes), 1024 (bytes), 2048 (bytes), and **4096 (bytes)**.

4-4.5 Hardware Monitors

This section allows the BIOS to display the status of hardware components monitored by the AwardBIOS. (*See the note below.)



Warning: Be Sure to read CPU, DDR memory, MCH chipset documents before select CPU, Memory and MCH core voltage settings. Incorrect settings may cause damage to the components and result in system failure. In addition, a very high DRAM or CPU frequency may cause the system to become unstable. When this occurs, reset the setting to the default setting.

CPU Warning Temperature

These features allows you to set the CPU warning temperature. If the CPU temperature reaches this pre-set threshold, an alarm will be activated, and a warning message will be displayed on the screen. To prevent CPU Overheat, the system fan will run at the full speed when the CPU temperature reaches 10°C below the threshold. The options for the CPU warning temperature are Disabled, 70°C/158°F, 75°C/167°F, **80°C/176°F**, 85°C/185°F, 90°C/194°F, 95°C/203°F and 100°C/212°F.

Chipset Warning Temperature

These features allows you to set the Chipset warning temperature. If the chipset temperature reaches the pre-set threshold, an alarm will be activated, and a warning message will be displayed on the screen. The options for the chipset warning temperature are Disabled, 50°C/122°F, 55°C/131°F, **60°C/140°F**, 65°C/149°F, 70°C/158°F, 75°C/167°F and 80°C/176°F.

The following temperatures will also be monitored:

Temperature Monitoring : Current System Temperature, Current CPU Temperature, Current Chipset Temperature.

The following fan speed item will be displayed:

CPU Fan 1 Speed/Fan 2 Speed/Fan 3 Speed//Fan 4 Speed/Fan 5 Speed

The following Voltage items will be monitored:

V_CORE (CPU)/V_CORE (Chipset)/+1.8V/+12V/-12V/+5V/+3.3V (Main)/+3.3V (Standby)/+3.3V (Analog)/+3.3V (Battery)

***Note:** In the Windows OS environment, the Supero Doctor III settings take precedence over the BIOS settings. When first installed, Supero Doctor III adopts the temperature threshold settings previously set in the BIOS. Any subsequent changes to these thresholds must be made within Supero Doctor, since the SD III settings override the BIOS settings. For the Windows OS to adopt the BIOS temperature threshold settings, please change the SDIII settings to be the same as those set in the BIOS.

4-4.6 Processor & Clock Options

Thermal Management

This setting allows the user to select the method to be used by the BIOS to control the thermal management of the system. The options are Thermal **Monitor 1 (On die throttling)** and Thermal Monitor 2 (Ratio & VID transition.).

Limit CPUID MaxVal

Select Enable to allow the user set the limit on CPUID Maximum Value. The options are Enabled and **Disabled**.

Hyper-Threading

Set this option to Enabled to activate the hyper-threading function of the CPU. Enabling the hyper-threading function makes each CPU appear as two to any programs that support it (you must have OS support also). The settings are Disabled and **Enabled**. (Set to Enabled for the Windows XP and Linux 2.4x operating systems. Disable this feature for operating systems that do not support Hyper-Threading.)

Auto Detect PCI CLK

Select Enabled to allow the system automatically detect the PCI clock. The options are **Enabled** and Disabled.

Spread Spectrum

Spread Spectrum is a technique used to stabilize a system by reducing the level of ElectroMagnetic Interference. The options are Enabled and **Disabled**.

CPU Overclocking

Select Enable to increase CPU frequency and system performance. The options are Enabled and **Disabled**.



Warning: Take Caution when using Overclocking. Improper Overclocking may result in system instability or system failure.

No Execute Mode Memory Protect

Set to **Enabled** to enable Execute Disable Bit and allow the processor to classify areas in memory where an application code can execute and where it cannot, and thus preventing a worm or a virus from inserting and creating a flood of codes to overwhelm the processor or damage the system during an attack.

(*Note: this feature is available when your OS and your CPU support the function of Execute Disable Bit.) The options are Disabled and **Enabled**. (Note: For more information regarding hardware/software support for this function, please refer to Intel's and Microsoft's web sites.)

4-4.7 DMI Event Log

DMI Event Log

This setting allows you to Enable or Disable the function of DMI Event Logging. The options are **Disabled** and Enabled.

Clear All DMI Event Logs

Select Yes and press <Enter> to clear all DMI event logs. The default setting is "Yes."

View DMI Event Log

Highlight this item and press <Enter> to view the contents of the event log.

Mark DMI Events as Read

Highlight this item and press <Enter> to mark the DMI events as read.

4-4.8 Console Redirection

Console Redirection

This setting allows you to Enable or Disable the function of Console Redirection. The options are **Disabled** and Enabled.

BAUD Rate

This item allows you to set the BAUD rate for console redirection. The options are 9600, **19200**, 38400, 57600K.

Agent Connect Via

This setting allows you to select the device to be used for Console Redirection.

Agent Wait Time (Min)

This setting allows you to set the wait time for the Console Redirection "Agent". The options are **1 (Min)**, 2 (Min), 4 (Min), and 8 (Min).

Agent After Boot

Select Enabled to keep the "Agent" running after boot. The options are Disabled, and **Enabled**.

4-5 Security

Choose Security from the Award BIOS main menu with the Left/Right arrow keys. You should see the following display:

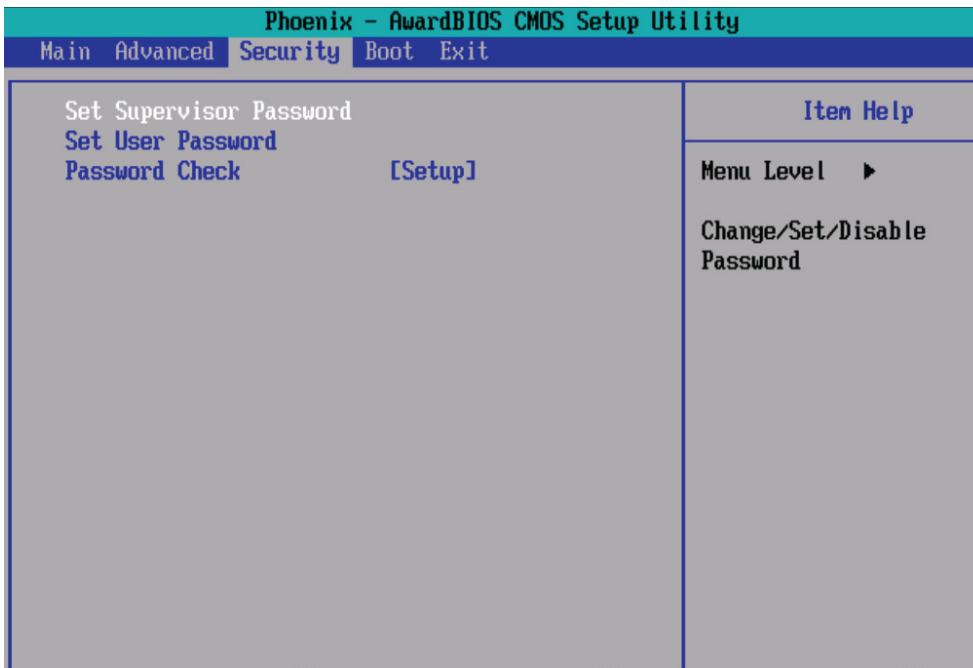

Set Supervisor Password

When the item Set Supervisor Password is highlighted on the above screen, press the <Enter> key. When prompted, type the Supervisor Password in the dialogue box to set or to change the Supervisor Password.

Set User Password

When the item Set User Password is highlighted on the above screen, press the <Enter> key. When prompted, type the User Password in the dialogue box to set or to change the User Password.

Password Check

This setting allows the user to determine if the password is required every time when the system boots up or if the password is required only when you enter the CMOS setup. The options are System and **Setup**.

4-6 Boot

Choose Boot from the Award BIOS main menu with the Left/Right arrow keys. You should see the following display:

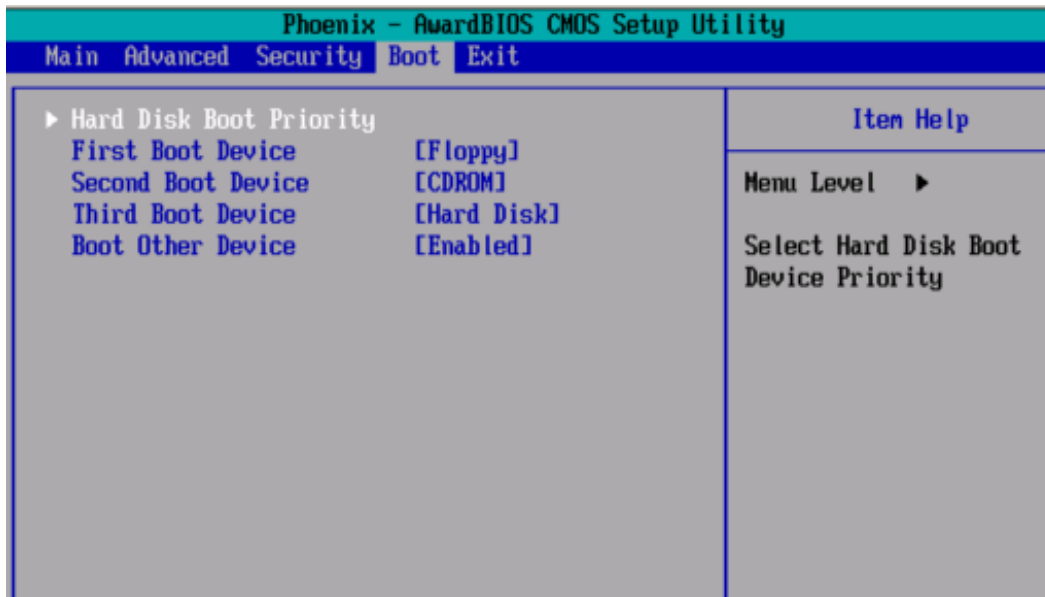

The Award BIOS attempts to load the operating system from devices specified by the users in a user-specified sequence.

Hard Disk Boot Priority

This item allows the user to select the Boot Priority of Hard Disk Devices.

First Boot Device/Second Boot Device/Third Boot Device

This item allows the user to set the first boot-up device. The options are Removable, Hard Disk, CD ROM, Legacy LAN, IBA GE Slot21 and Disabled. The default setting for the First Boot Device is **Removable**, for the Second Boot Device is **CDROM**, for the Third Boot Device is **Hard Disk**.

Boot Other Device

If enabled, this option enables the BIOS to load the OS from another device rather than the ones that have been specified as the first, second and third boot up devices. The settings are **Enabled** and Disabled.

4-7 Exit

Choose Exit from the Award BIOS main menu with the Left/Right arrow keys. You should see the following display:

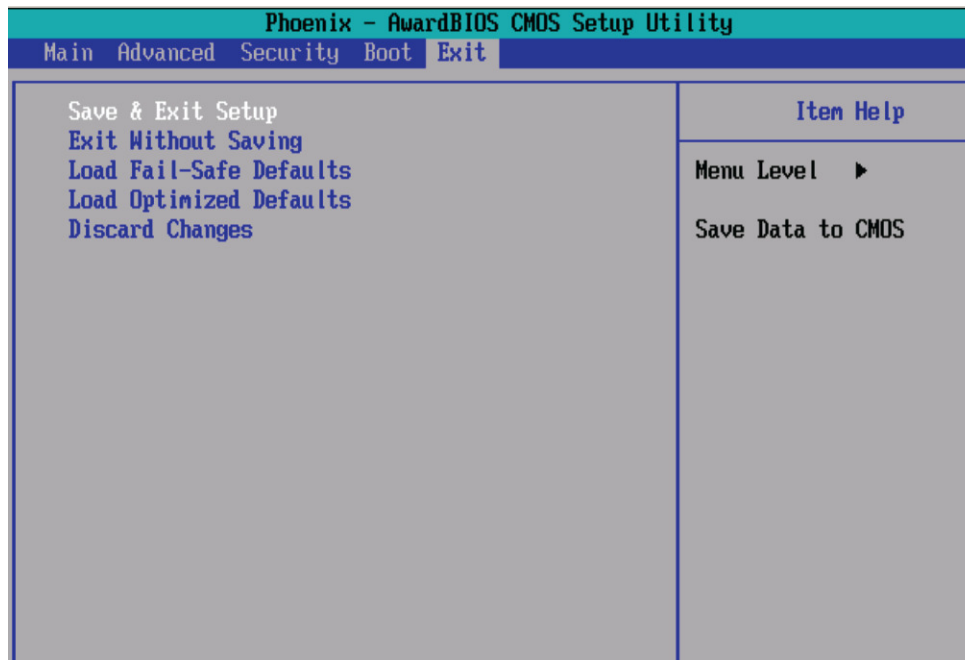

Save & Exit Setup

When the item Save & Exit Setup is highlighted, press <Enter> to save the changes you've made in the BIOS program (CMOS) and exit. Your system should, then, continue with the boot-up procedure.

Exit without Saving

When the item Exit without Saving is highlighted, press <Enter> to exit the Setup routine without saving any changes you may have made. Your system should then continue with the boot-up procedure.

Load Fail-Safe Defaults

Highlight this item and hit <Enter> to load the default settings for all items in the BIOS Setup. These are the safest settings to use.

Load Optimized Defaults

Highlight this item and hit <Enter> to load the optimized settings for all items in the BIOS Setup. These settings provide you with optimal system performance.

Discard Changes

When the item Discard Changes is highlighted, press <Enter> to discard any changes you made to the BIOS settings and to stay in the BIOS Setup. Your system should then continue with the boot-up procedure.

Appendix A

BIOS POST Messages and LE1/LE2 Indicators

During the Power-On Self-Test (POST), the BIOS will check for problems. If a problem is found, the BIOS will activate an alarm or display a message. The following is a list of such BIOS messages.

A-1 BIOS POST Beep Codes

Beeps	Error Messages
1 repetitive long beep	Memory Module Error
1 long beep+2 short beeps	VGA Errors
1 long continuous beep (OH LED on)	System Overheat

A-2 LE1/LE2 Indicators

State	LE1 Indicator		LE2 Indicator	
PWR-ON to POST	Green	On	Yellow	On
ECC Memory Testing	Green	Flash	Yellow	Flash
PCI Bus Initializing	Green	On	Yellow	Flash
VGA Initializing	Green	Flash	Yellow	On
System Normal (After POST)	Off	N/A	Off	N/A

Notes

Appendix B

Award BIOS POST Codes

This section lists the POST (Power On Self Testing) Codes for the Award BIOS.

POST (hex)	Description
CFh	Test CMOS R/W functionality.
C0h	Early chipset initialization: - Disable shadow RAM - Disable L2 cache (socket 7 or below) - Program basic chipset registers
C1h	Detect memory - Auto detection of DRAM size, type and ECC. - Auto detection of L2 cache (socket 7 or below)
C3h	Expand compressed BIOS code to DRAM.
C5h	Call chipset hook to copy BIOS back to E000 & F000 shadow RAM.
0h1	Expand the Xgroup codes located in physical address 1000:0
02h	Reserved
03h	Initial Superio_Early_Init switch
04h	Reserved
05h	1. Blank out screen. 2. Clear CMOS error flag.
06h	Reserved
07h	1. Clear 8042 interface. 2. Initialize 8042 self-test.
08h	1. Test special keyboard controller for Winbond 977 series Super I/O chips. 2. Enable keyboard interface.
09h	Reserved
0Ah	1. Disable PS/2 mouse interface (optional). 2. Auto detect ports for keyboard and mouse followed by a port and interface swap (optional). 3. Reset keyboard for Winbond 977 series Super I/O chips.
0Bh	Reserved
0Ch	Reserved
0Dh	Reserved
0Eh	Test F000h segment shadow to see whether it is R/W-able or not. If test fails, keep beeping the speaker.
0Fh	Reserved
10h	Auto detect flash type to load appropriate flash R/W codes into the run time area in F000 for ESCD & DMI support.

POST (hex)	Description
11h	Reserved
12h	Use walking 1's algorithm to check out interface in CMOS circuitry. Also set real-time clock power status, and then check for override.
13h	Reserved
14h	Program cipset defaults into chipset. Chipset default values are MODBINable by OEM customers.
15h	Reserved
16h	Initial Early_Init_Onboard_Generator switch.
17h	Reserved
18h	Detect CPU information including brand, SMI type (Cyril or Intel) and CPU level (586 or 686).
19h	Reserved
1Ah	Reserved
1Bh	Initial interrupts vector table, If no special specified, all H/W interrupts are directed to SPURIOUS_INT_HDLR & S/W interrupts to SPURIOUS_soft_HDLR.
1Ch	Reserved
1Dh	Initial EARLY_PM_INIT switch.
1Eh	Reserved
1Fh	Load keyboard matrix (notebook platform).
20h	Reserved
21h	HPM initialization (notebook platform)
22h	Reserved
23h	<ol style="list-style-type: none"> 1. Check validity of RTC value, e.g. a value of 5Ah is an invalid value for RTC minute 2. Load CMOS settings into BIOS stack. If CMOS checksum fails, use default value instead. 3. Prepare BIOS resource map for PCI and PnP use. If ESCD is valid, take into consideration of the ESCD's legacy information. 4. Onboard clock generator initialization. Disable respective clock resource to empty PCI and DIMM slots. 5. Early PCI initialization: <ul style="list-style-type: none"> - Enumerate PCI bus number. - Assign memory and I/O resource. - Search for a valid VGA device and VGA BIOS and put it into C000:0.
24h	Reserved
25h	Reserved
26h	Reserved
27h	Initialize INT 09 buffer.
28h	Reserved
29h	<ol style="list-style-type: none"> 1. Program CPU internal MTRR (P6 & PII) for 0-64K memory address. 2. Initialize the APIC for Pentium class CPU. 3. Program early chipset according to CMOS setup. Example: onboard IDE controller. 4. Measure CPU speed. 5. Invoke video BIOS.

POST (hex)	Description
2Ah	Reserved
2Bh	Reserved
2Ch	Reserved
2Dh	1. Initialize multi-language. 2. Put information on screen display, including Award title, CPU type, CPU speed, etc.
2Eh	Reserved
2Fh	Reserved
30h	Reserved
31h	Reserved
32h	Reserved
33h	Reset keyboard except Winbond 977 series Super I/O chips.
34h	Reserved
35h	Reserved
36h	Reserved
37h	Reserved
38h	Reserved
39h	Reserved
3Ah	Reserved
3Bh	Reserved
3Ch	Test 8254
3Dh	Reserved
3Eh	Test 8259 interrupt mask bits for channel 1.
3Fh	Reserved
40h	Test 8259 interrupt mask bits for channel 2.
41h	Reserved
42h	Reserved
43h	Test 8259 functionality.
44h	Reserved
45h	Reserved
46h	Reserved
47h	Initialize EISA slot.
48h	Reserved
49h	1. Calculate total memory by testing the last double word of each 64K page. 2. Program writes allocation for AMD K5 CPU.
4Ah	Reserved
4Bh	Reserved

POST (hex)	Description
4Ch	Reserved
4Dh	Reserved
4Eh	<ol style="list-style-type: none"> 1. Program MTRR of M1 CPU. 2. Initialize L2 cache for P6 class CPU & program CPU with proper cacheable range. 3. Initialize the APIC for P6 class CPU. 4. On MP platform, adjust the cacheable range to smaller one in case the cacheable ranges between each CPU are not identical.
4Fh	Reserved
50h	Initialize USB.
51h	Reserved
52h	Test all memory (clear all extended memory to 0).
53h	Reserved
54h	Reserved
55h	Display number of processors (multi-processor platform).
56h	Reserved
57h	<ol style="list-style-type: none"> 1. Display PnP logo. 2. Early ISA PnP initialization. <ul style="list-style-type: none"> - Assign CSN to every ISA PnP device.
58h	Reserved
59h	Initialize the combined Trend Anti-Virus code.
5Ah	Reserved
5Bh	Show message for entering AWDFLASH.EXE from FDD (optional feature)
5Ch	Reserved
5Dh	<ol style="list-style-type: none"> 1. Initialize Init_Onboard_Super_IO switch. 2. Initialize Init_Onboard_AUDIO switch.
5Eh	Reserved
5Fh	Reserved
60h	Ok to enter setup utility; i.e. not until this POST stage can users enter the CMOS utility.
61h	Reserved
62h	Reserved
63h	Reserved
64h	Reserved
65h	Initialize PS/2 mouse.
66h	Reserved
67h	Prepare memory size information for function call: INT 15h ax=E820h
68h	Reserved
69h	Turn on L2 cache.
70h	Reserved

POST (hex)	Description
71h	Reserved
72h	Reserved
73h	(Optional feature) Enter AWDFLASH.EXE if: - AWDFLASH is found in floppy drive. - ALT+F2 is pressed
74h	Reserved
75h	Detect and install all IDE devices: HDD, LS120, ZIP, CD-ROM, etc.
76h	Reserved
77h	Detect serial ports and parallel ports.
78h	Reserved
79h	Reserved
7Ah	Detect and install co-processor.
7Bh	Reserved
7Ch	Reserved
7Dh	Reserved
7Eh	Reserved
7Fh	1. Switch back to text mode if full screen logo is supported. - If errors occur, report errors and wait for keys. - If no errors occur or F1 key is pressed to continue: Clear EPA or customization logo.
80h	Reserved
81h	Reserved
82h	1. Call chipset power management hook. 2. Recover the text font used by EPA logo (not for full screen logo).
83h	Save all data in stack back to CMOS.
84h	Initialize ISA PnP boot devices.
85h	1. USB final initialization. 2. NET PC: Build SYSID structure. 3. Switch screen back to text mode. 4. Set up ACPI table at top of memory. 5. Invoke ISA adapter ROMS. 6. Assign IRQs to PCI devices. 7. Initialize APM. 8. Clear noise of IRQs.
86h	Reserved
87h	Reserved
88h	Reserved
89h	Reserved
90h	Reserved
91h	Reserved
92h	Reserved

POST (hex)	Description
93h	Read HDD boot sector information for Trend Anti-Virus.
94h	<ol style="list-style-type: none"> 1. Enable L2 cache. 2. Program boot up speed. 3. Chipset final initialization. 4. Power management final initialization. 5. Clear screen and display memory table. 6. Program K6 write allocation. 7. Program P6 class write combining.
95h	<ol style="list-style-type: none"> 1. Program daylight saving 2. Update keyboard LED and typematic rate.
96h	<ol style="list-style-type: none"> 1. Build MP table. 2. Build and update ESCD. 3. Set CMOS century to 20h or 19h. 4. Load CMOS time into DOS timer tick. 5. Build MSIRQ routing table.
Ffh	Boot attempt (INT 19h).

Appendix C

Software Installation

After all the hardware has been installed, you must first configure Intel's ICH7R SATA RAID* before you install the Windows Operating System and other software drivers.

*If you do not wish to configure onboard SATA RAID functions, please go directly to Section C-4 on page C-15 for Operating System & Other Software Installation.

C-1 Introduction to Serial ATA and Parallel ATA

To configure the SATA RAID functions, you must first use the Intel ICH7R SATA RAID Utility program to configure the RAID Level that you desire before installing the Windows XP/2000/2003 operating system and other software drivers. (The necessary drivers are all included on the Supermicro CD that came packaged with your motherboard.) Note that the current version of the ICH7R SATA RAID Utility can only support Windows XP/2000/2003 Operating Systems.

Serial ATA (SATA)

Serial ATA (SATA) is a physical storage interface that uses a single cable with a minimum of four wires to create a point-to-point connection between devices. It is a serial link, which supports transfer rates up to 3Gbps. Because the serial cables used in SATA are thinner than the traditional cables used in Parallel ATA (PATA), SATA systems have better airflow and can be installed in smaller chassis than Parallel ATA. In addition, the cables used in PATA are limited to a length of 40cm, while Serial ATA cables can be up to one meter in length. Overall, SATA provides better functionality than PATA.

Introduction to Intel ICH7R Serial RAID

Located in the South Bridge of the 955X Glenwood chipset, the I/O Controller Hub (ICH7R) provides the I/O subsystem with access to the rest of the system. It supports a 2-channel UltraATA/100 Bus Master IDE controller (PATA) and four Serial ATA (SATA) ports. The ICH7R supports the following PATA and SATA device configurations: Legacy mode and Native mode.

RAID Configurations

The following types of RAID configurations are supported:

RAID 0 (Data Striping): this writes data in parallel, interleaved ("striped") sections of two hard drives. Data transfer rate is doubled over using a single disk.

RAID1 (Data Mirroring): an identical data image from one drive is copied to another drive. The second drive must be the same size or larger than the first drive.

RAID 10 (Striping & Mirroring): RAID 0 and 1 schemes are combined (without parity information) to get the benefits of both.

RAID 5: both data and parity information are striped and mirrored across three or more hard drives.

Intel Matrix Storage

The Intel Matrix Storage, supported by the ICH7R, allows the user to create RAID 0 and RAID1 set by using only two identical hard disk drives. The Intel Matrix Storage Technology creates two partitions on each hard disk drive and generate a virtual RAID0 and RAID1sets. It also allows you the change the HDD partition size without any data.

Configuring BIOS settings for SATA RAID Functions (Native Mode)

1. Press the key during system bootup to enter the BIOS Setup Utility.

Note: If it is the first time powering on the system, we recommend you load the Optimized Default Settings. If you have already done so, please skip to Step 3.

2. Use the arrow keys to select the "Exit" Settings. Once in the "Exit" settings, Scroll down to select "Load Optimized Default Settings" and press the <Enter> key. Select "OK" to confirm the selection. Press the <Enter> key to load the default settings for the BIOS.

3. Use the arrow keys to select the "Advanced" section in BIOS.

4. Scroll down to "Advanced Chipset Control" and press the <Enter> key to select this option.

5. Select "On-Chip Serial ATA" and press the <Enter> key. When the sub-menu appears, select "Enhanced Mode".

6. Scroll up to "SATA Mode" and press the <Enter> key to select this option. When the sub-menu appears, select "RAID".

7. Tap the "Esc" key and scroll down to "Exit". Select "Save and Exit" from the "Exit" menu. Press the <Enter> key to save the changes and exit the BIOS.

8. Once you've exited the BIOS Utility, the system will re-boot.

9. During the system boot-up, press the <Ctrl> and <I> keys simultaneously to run the Adaptec RAID Configuration Utility when prompted by the following message:
Press <Ctrl> <I> for Adaptec RAID Configuration Utility.

Using the Intel ICH7R SATA RAID Utility Program

1. Creating, Deleting and Resetting RAID Volumes:

- a. After the system exits from the BIOS Setup Utility, the system will automatically reboot. The following screen appears after Power-On Self Test.

```

RAID Volumes :
None defined.

Physical Disks :
Port Drive Model      Serial #              Size   Type/Status(Vol ID)
0   WDC WD2500SD-01K   WD-WMAL72034971      232.9GB Non-RAID Disk
1   WDC WD2500SD-01K   WD-WMAL72034599      232.9GB Non-RAID Disk
2   WDC WD2500JD-00F   WD-WMAEH1376109      232.9GB Non-RAID Disk
3   WDC WD2500JD-00F   WD-WMAEH1449527      232.9GB Non-RAID Disk

Press <CTRL-I> to enter Configuration Utility...

Adaptec SCSI BIOS v4.30.0
Copyright 2003 Adaptec, Inc. All Rights Reserved.

<<< Press <Ctrl><A> for SCSISelect(TM) Utility! >>>

Slot Ch ID LUN  Vendor      Product              Size  Bus Status
-----
04  A  10  0

```

- b. When you see the above screen, press the <Ctrl> and the <I> keys simultaneously to have the main menu of the SATA RAID Utility appear:

***Note:** All graphics and screen shots shown in the manual are for reference only. The screen shots shown in the manual do not imply Supernicro's endorsement or non-endorsement on any 3rd party's product. Your screens may or many not look exactly the same as the graphics shown in this manual.

Creating a RAID 0 Volume:

- a. Select "Create RAID Volume" from the main menu and press the <Enter> key. The following screen will appear:

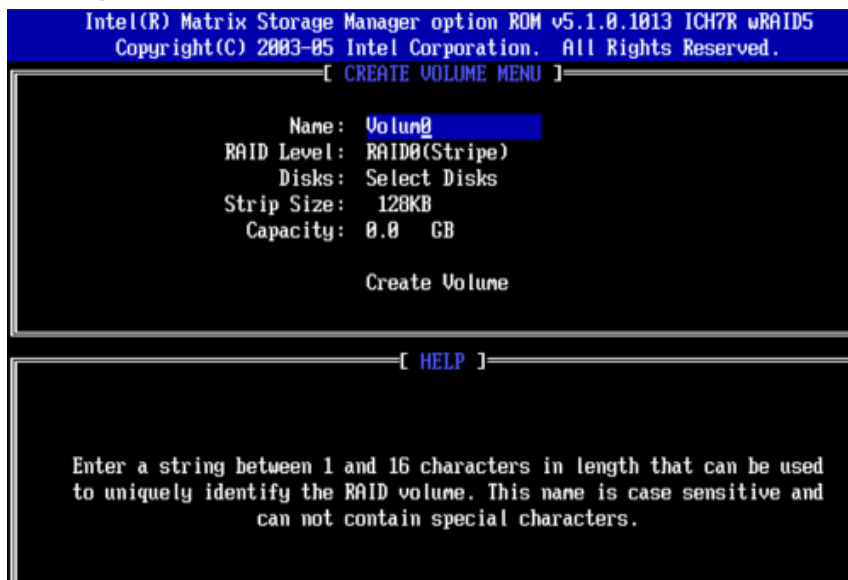

- b. Specify a name for the **RAID 0** set and press the <Tab> key or the <Enter> key to go to the next field. (You can use the <Esc> key to select the previous menu.)
- c. When RAID Level item is highlighted, press the <Up Arrow>, <Down Arrow> keys to select **RAID 0 (Stripe)** and hit <Enter>.
- d. When the Disks item is highlighted, press <Enter> to select the HDD to configure as RAID. The following pop-up screen (*See the Note on Page C-3) displays:

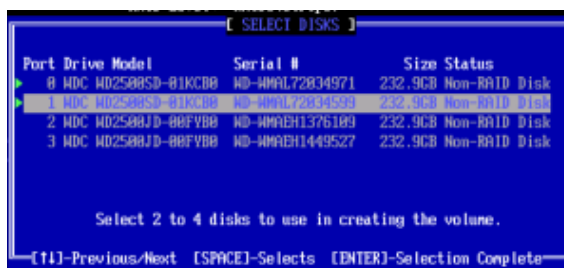

- e. Use the <Up Arrow>, <Down Arrow> keys to highlight a drive and press <Space> to select it. A triangle appears to confirm the selection of the drive.
- f. Use the <Up Arrow>, <Down Arrow> keys to select the stripe size, ranging from 4 KB to 128 KB for the RAID 0 array, and hit <Enter>. (*Note: For a server, please use a lower stripe size, and for a multimedia system, use a higher stripe size. The default stripe size is 128 KB.)
- g. Press <Enter> when the Create Volume item is highlighted. A warning message displays.
- h. When asked "Are you sure you want to create this volume (Y/N), press "Y" to create the RAID volume, or type "N" to go back to the Create Volume menu.

Creating a RAID 1 Volume:

- a. Select "Create RAID Volume" from the main menu and press the <Enter> key. The following screen will appear:

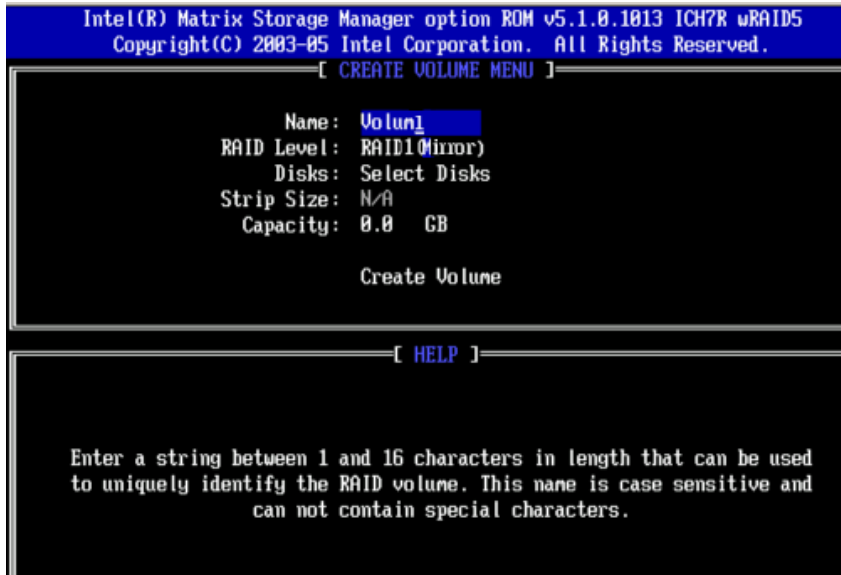

- b. Specify a name for the **RAID 1** set and press the <Tab> key or the <Enter> key to go to the next field. (You can use the <Esc> key to select the previous menu.)
- c. When RAID Level item is highlighted, press the <Up Arrow>, <Down Arrow> keys to select **RAID 1 (Mirror)** and hit <Enter>.
- d. When the Capacity item is highlighted, enter your RAID volume capacity and hit <Enter>. The default setting is the maximum capacity allowed.
- e. Press <Enter> when the Create Volume item is highlighted. A warning message displays.
- f. When asked "Are you sure you want to create this volume (Y/N), press "Y" to create the RAID volume, or type "N" to go back to the Create Volume menu.

Creating a RAID 10 (RAID 1+ RAID 0):

- a. Select "Create RAID Volume" from the main menu and press the <Enter> key. The following screen will appear:

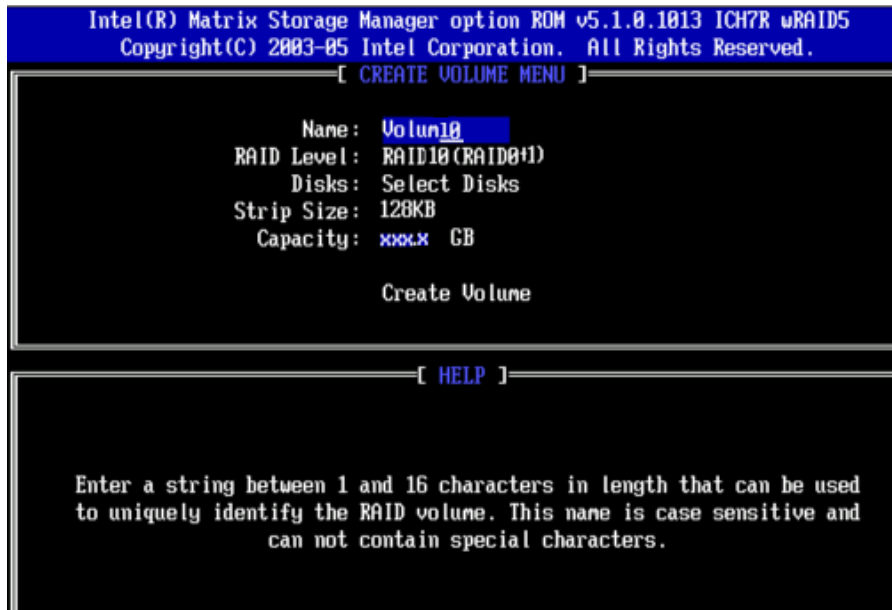

- b. Specify a name for the **RAID 10** set and press <Enter>.
- c. When RAID Level item is highlighted, use the <Up Arrow>, <Down Arrow> keys to select **RAID 10 (RAID1 + RAID0)** and hit <Enter>.
- d. When the Stripe Size is highlighted, use the <Up Arrow>, <Down Arrow> keys to select the stripe size from 4 KB to 128 KB for your RAID 10 and hit <Enter>. The default setting is 6 4KB. (*Note: For a server, please use a lower stripe size, and for a multimedia system, use a higher stripe size.)
- e. When the RAID Volume Capacity item is highlighted, enter your RAID volume capacity and hit <Enter>. The default setting is the maximum capacity allowed.
- f. Press <Enter> when the Create Volume item is highlighted. A warning message displays.
- f. When asked "Are you sure you want to create this volume (Y/N), press "Y" to create the RAID volume, or type "N" to go back to the Create Volume menu.

Creating a RAID 5 Set (Parity):

- a. Select "Create RAID Volume" from the main menu and press the <Enter> key. The following screen will appear:

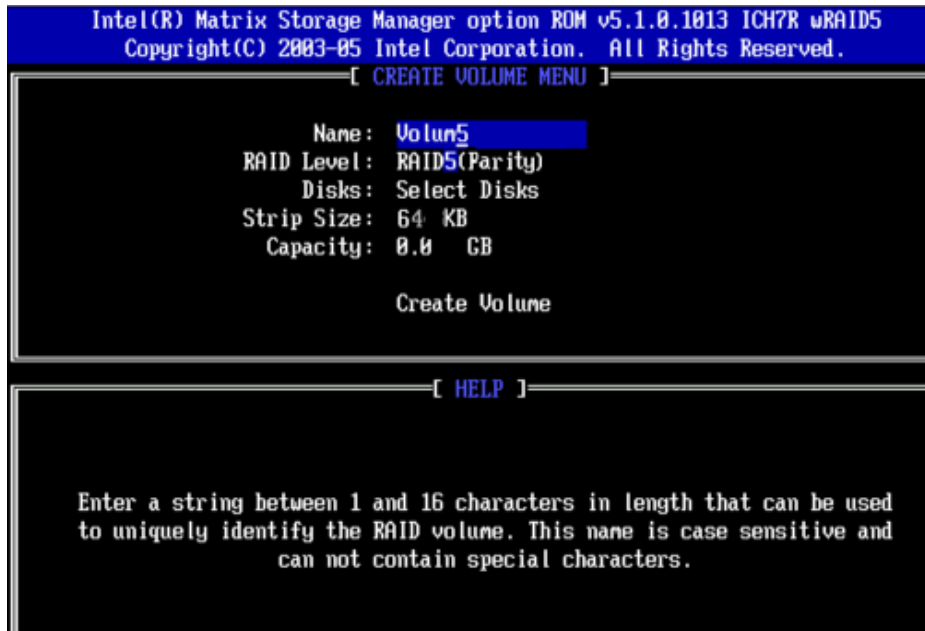

- b. Specify a name for the **RAID 5** set and press <Enter>.
- c. When the Raid Level is highlighted, use the <Up Arrow>, <Down Arrow> keys to select **RAID 5 (Parity)** and hit <Enter>.
- d. When the Disk item is highlighted, press <Enter> to select the HDD to configure as RAID. The following pop-up screen (*See the Note on Page C-3) displays:

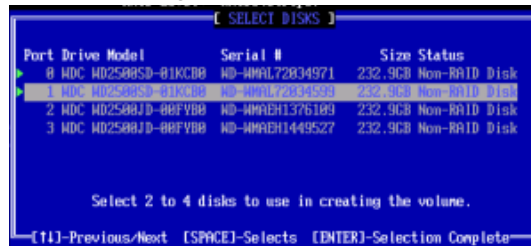

- e. Use the <Up Arrow>, <Down Arrow> keys to highlight a drive and press <Space> to select it. A triangle appears to confirm the selection of the drive.
- f. Use the <Up Arrow>, <Down Arrow> keys to select the stripe size, ranging from 4 KB to 128 KB for the RAID 5 array, and hit <Enter>. (*Note: For a server, please use a lower stripe size, and for a multimedia system, use a higher stripe size. The default stripe size is 128 KB.)
- g. Enter your desired RAID volume capacity and press <Enter> when the capacity item is highlighted. The default setting is the maximum capacity allowed.
- h. Press Enter when the Create Volume item is highlighted. A warning message displays.
- h. When asked "Are you sure you want to create this volume (Y/N), press "Y" to create the RAID volume, or type "N" to go back to the Create Volume menu.

Deleting RAID Volume:



(Warning: Be sure to back up your data before deleting a RAID set. You will lose all data on the disk drives when deleting a RAID set.)

- a. From the main menu, select item2-Delete RAID Volume, and press <Enter>.
- b. Use the <Up Arrow>, <Down Arrow> keys to select the RAID set you want to delete and press . A Warning message displays.
- c. When asked "Are you sure you want to delete this volume (Y/N), press "Y" to delete the RAID volume, or type "N" to go back to the Delete Volume menu.

Resetting to Non-RAID and Resetting a RAID HDD



(Warning: Be cautious when you reset a RAID volume HDD to non-RAID or Resetting a RAID HDD. Resetting a RAID volume HDD or Restting a RAID HDD will reformat the HDD and delete all internal RAID structure on the drive.)

- a. From the main menu, select item3-Reset Disks to Non- RAID, and press <Enter>. The following screen will appear:

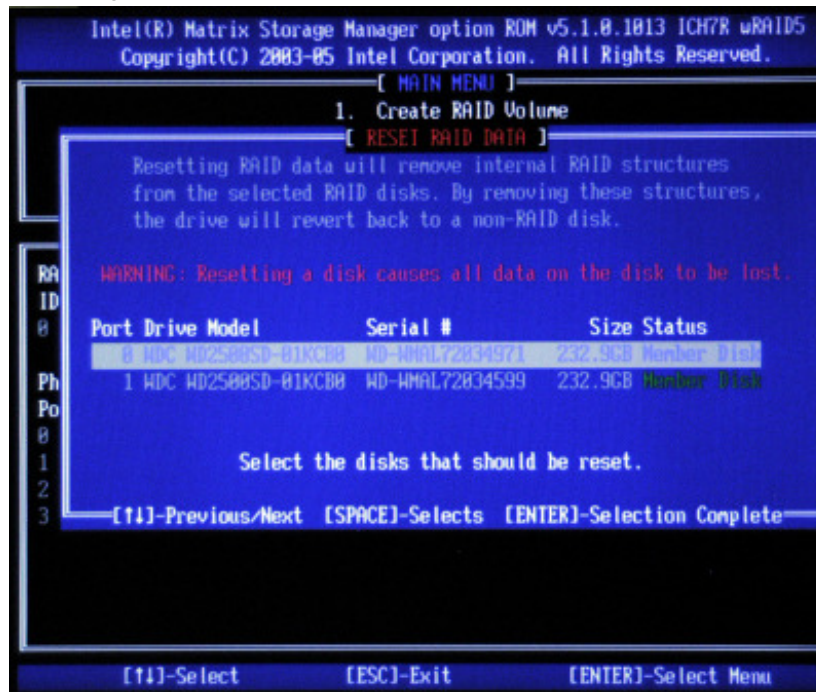

- b. Use the <Up Arrow>, <Down Arrow> keys to highlight the RAID set drive to reset and press <Space> to select.
- c. Press <Enter> to reset the RAID set drive. A Warning message displays.
- d. Press "Y" to reset the drive, or type "N" to go back to the main menu.

Exiting the Intel Matrix Storage Manager Utility:

- a. From the main menu, select item4-Exit, and press <Enter>. A warning message will appear.
- b. Press "Y" to reset the drive, or type "N" to go back to the main menu.

C-2 Installing the Windows XP/2000/2003 for systems with RAID Functions

Installing a New Operating System-the Windows XP/2000/2003 OS

- a. Insert Microsoft's Windows XP/2000/2003 Setup CD in the CD Driver, and the system will start booting up from CD.
- b. Press the <F6> key when the message-" Press F6 if you need to install a third party SCSI or RAID driver" displays.
- c. When the Windows XP/2000/2003 Setup screen appears, press "S" to specify additional device(s).
- d. Insert the driver diskette-"Intel AA RAID XP/2000/2003 Driver for ICH7R into Drive A: and press the <Enter> key.
- e. Choose the Intel(R)82801GR/GH SATA RAID Controller from the list indicated in the XP/2000/2003 Setup Screen, and press the <Enter> key.
- f. Press the <Enter> key to continue the installation process. (If you need to specify any additional devices to be installed, do it at this time.) Once all devices are specified, press the <Enter> key to continue with the installation.
- g. From the Windows XP/2000/2003 Setup screen, press the <Enter> key. The XP/2000/2003 Setup will automatically load all device files and then, continue the Windows XP/2000/2003 installation.
- h. After Windows XP/2000/2003 Installation is completed, the system will automatically reboot.
- i. Insert Supermicro's CD that came with the package into the CD Drive during system reboot, and the following screen will appear:

(*Note: the current version of the ICH7R SATA RAID Utility can only support the Windows XP/2000/2003 Operating System.)

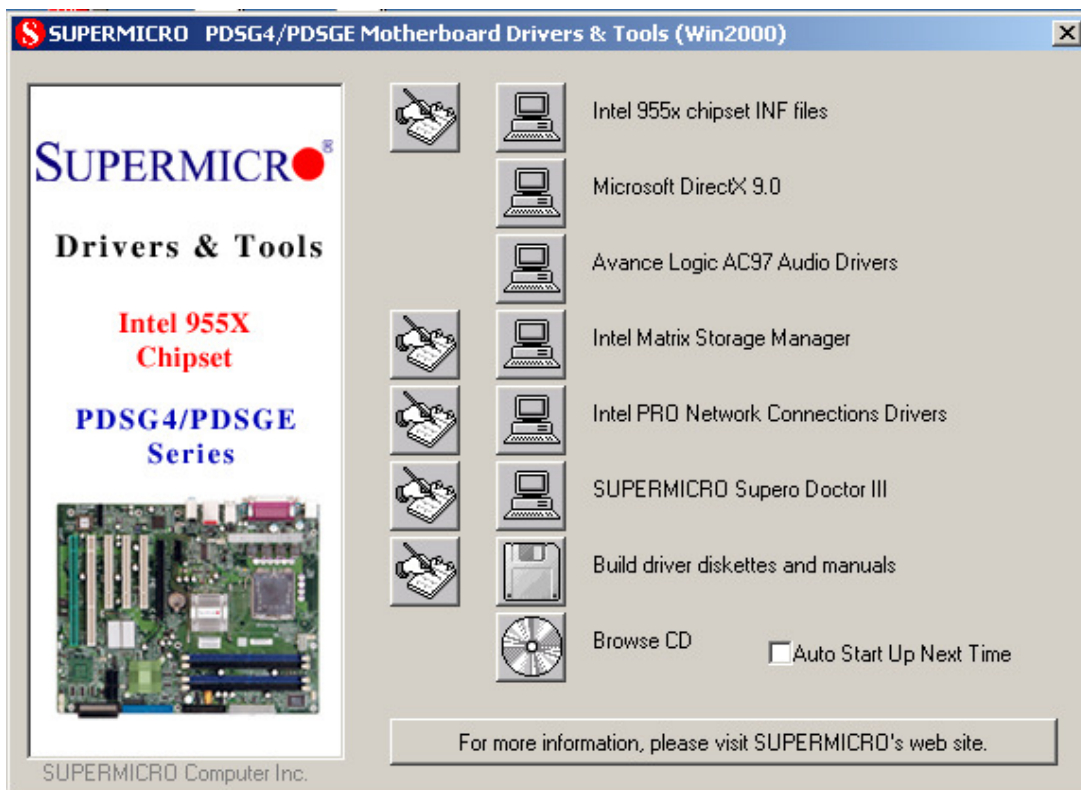

***Note:** Click the icons showing a hand writing on the paper to view the readme files for each item. Click the computer icons to the right of these items to install each item (from top to the bottom) one at a time. **After installing each item, you must re-boot the system before moving on to the next item on the list.** The bottom icon with a CD on it allows you to view the entire contents of the CD.

C-3 Installing Intel Application Accelerator Utility

a. When the above screen appears, click on the icon marked "Application Accelerator RAID Edition" on the screen, and the following screen will appear:

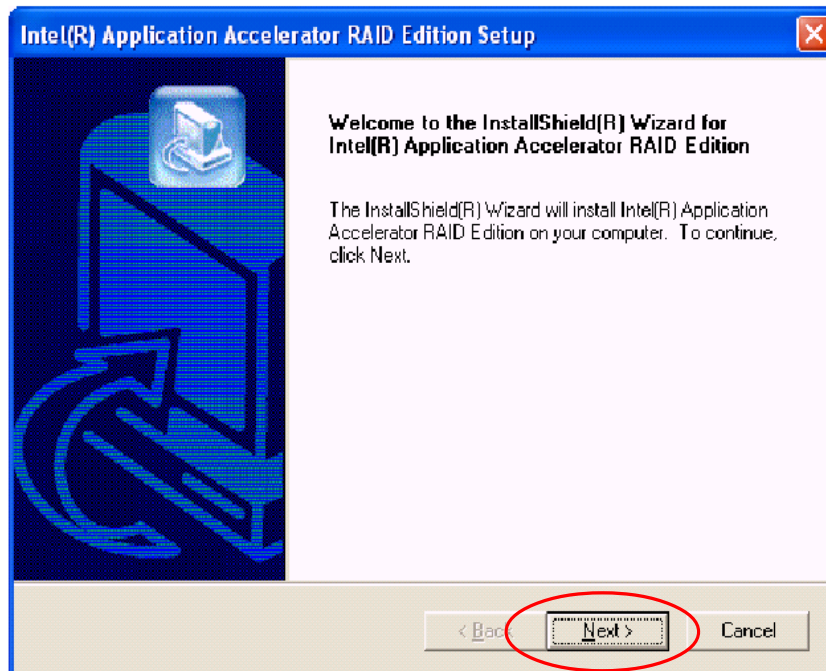
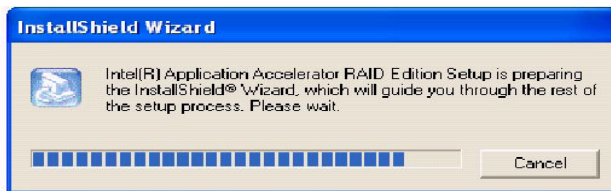

b. When the above screen appears, click on the icon marked "Next" on the screen, and the following screen will appear:

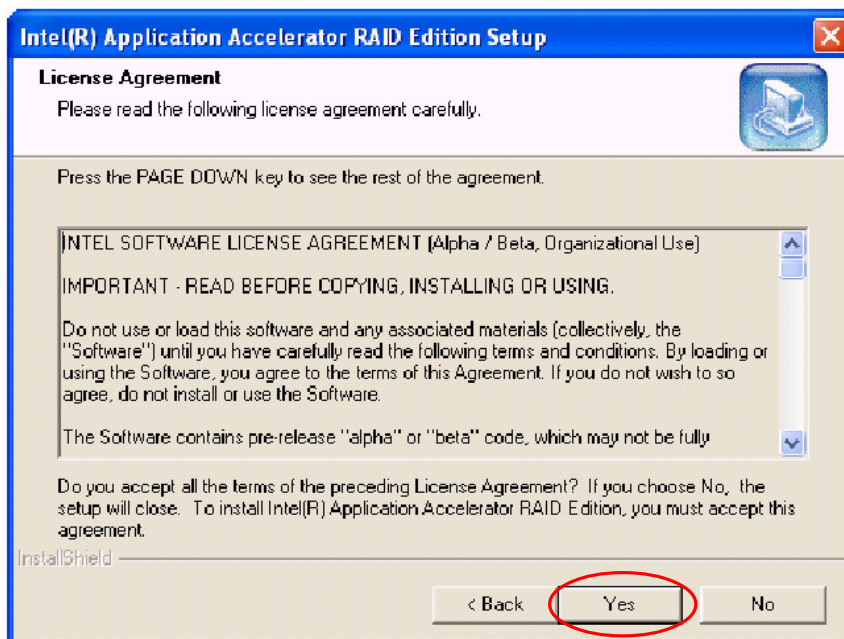

- c. After reading the License Agreement, click on the icon marked "Yes" on the screen, and the following screen will appear:
- d. Specify the folder that you want the program to be installed in and then, click on the icon marked "Next" to begin the installation process.

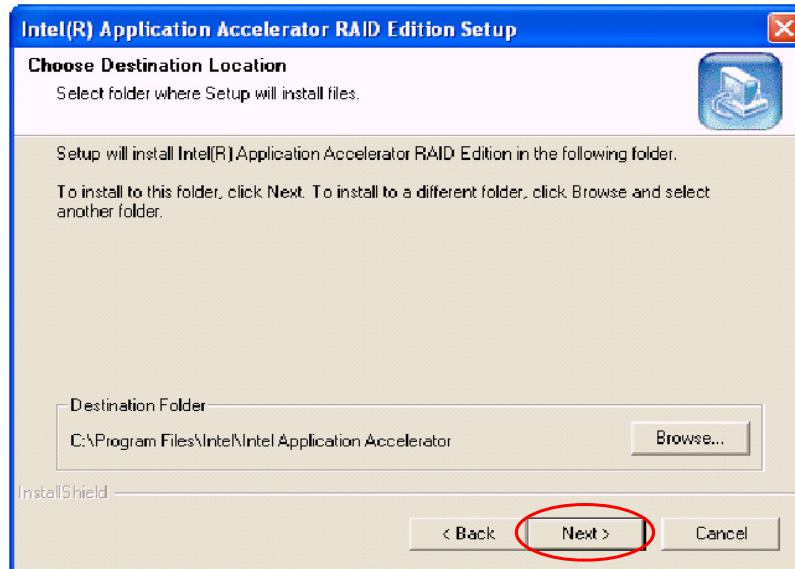

- e. Specify a program folder where you want the Setup to add the program icon as shown in the following screen and click on the icon marked "Next".

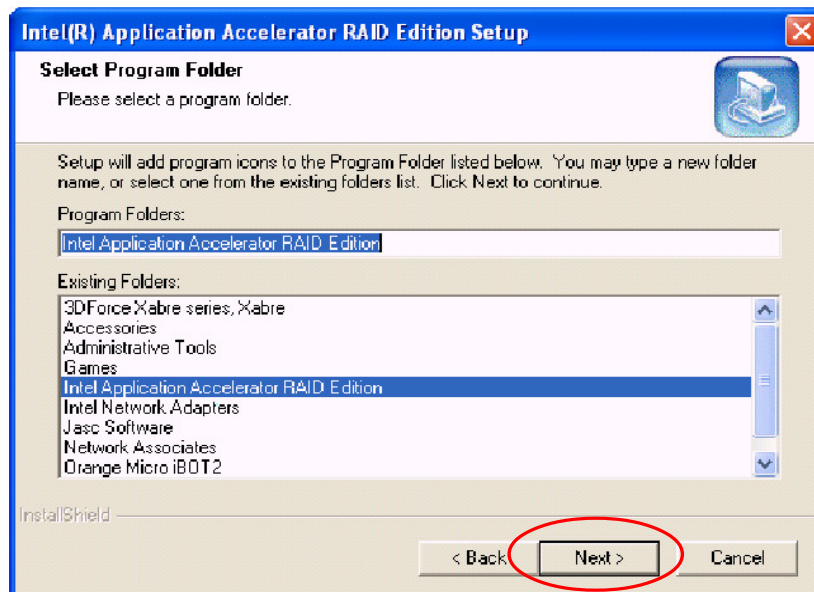

f. The following screen will appear to display the status of the Intel Application Accelerator RAID Edition Installation.

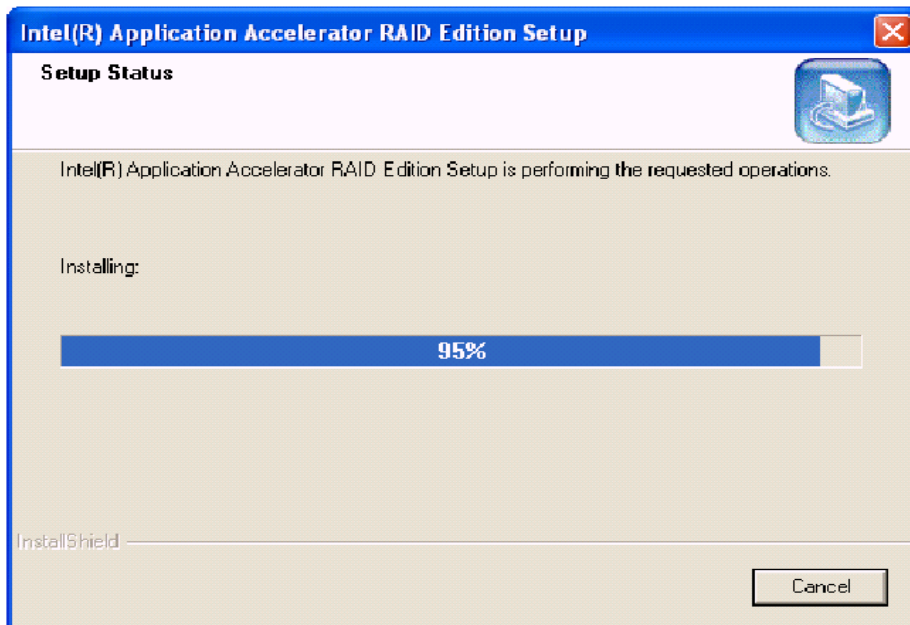

g. Once the Application Accelerator RAID Edition installation is completed, the following screen will appear and the system will start to re-boot.

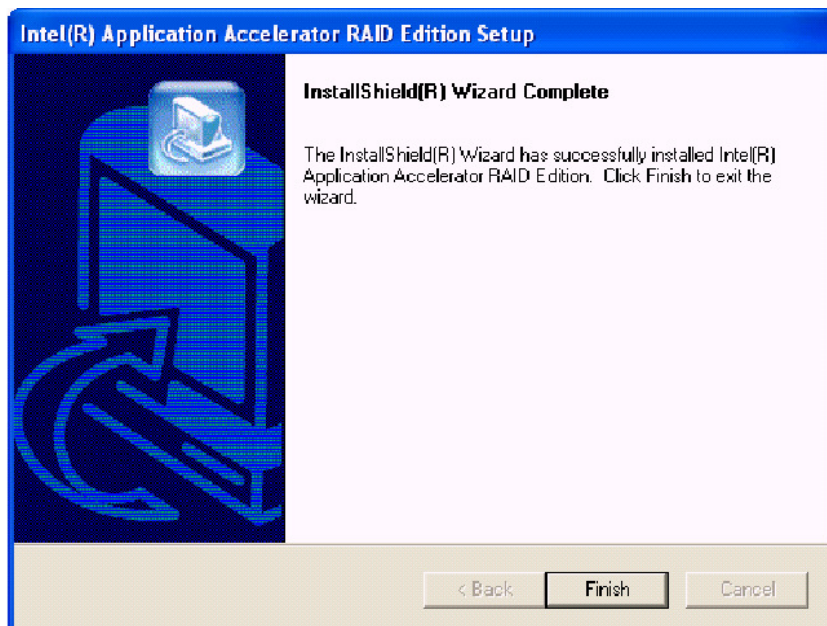

***Note:** Once the XP/2000/2003 Operating System is installed, please read the "Readme text files" for the instructions to use the SATA RAID Utility in the Windows XP/2000/2003 OS environment.

C-4 Installing the Operating System and other Software Programs

After all the hardware has been installed, you must first install the operating system, and then, other software drivers. The necessary drivers are all included on the Supermicro CDs that came packaged with your motherboard. (***Note:** for the Windows 2003 OS, please refer to Page C-14.)

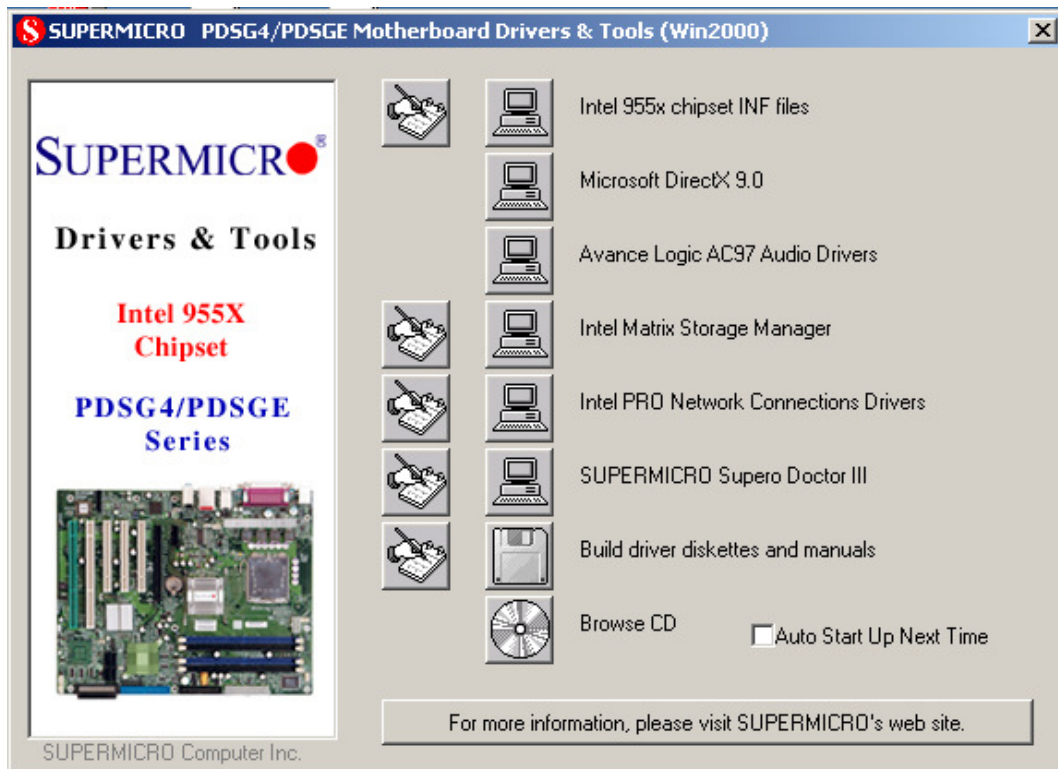

Driver/Tool Installation Display Screen

***Note:** Click the icons showing a hand writing on the paper to view the readme files for each item. Click the computer icons to the right of these items to install each item (from top to the bottom) one at a time. **After installing each item, you must re-boot the system before moving on to the next item on the list.** The bottom icon with a CD on it allows you to view the entire contents of the CD.

Supero Doctor III

The Supero Doctor III program is a Web-base management tool that supports remote management capability. It includes Remote and Local Management tools. The local management is called the SD III Client. The Supero Doctor III program included on the CDROM that came with your motherboard allows you to monitor the environment and operations of your system. Supero Doctor III displays crucial system information such as CPU temperature, system voltages and fan status. See the Figure below for a display of the Supero Doctor III interface.

***Note 1:** The default user name and password are ADMIN.

***Note 2:** In the Windows OS environment, the Supero Doctor III settings take precedence over the BIOS settings. When first installed, Supero Doctor III adopts the temperature threshold settings previously set in the BIOS. Any subsequent changes to these thresholds must be made within Supero Doctor, since the SD III settings override the BIOS settings. For the Windows OS to adopt the BIOS temperature threshold settings, please change the SDIII settings to be the same as those set in the BIOS.

Supero Doctor III Interface Display Screen-I (Health Information)



Supero Doctor III Interface Display Screen-II (Remote Control)



(*Note: SD III Software Revision 1.0 can be downloaded from our Website at: ftp://ftp.supermicro.com/utility/Supero_Doctor_III/. You can also download SDIII User's Guide at: <http://www.supermicro.com/PRODUCT/Manuals/SDIII/UserGuide.pdf>. For Linux, we will still recommend Supero Doctor II.)

Notes

(Disclaimer)

The products sold by Supermicro are not intended for and will not be used in life support systems, medical equipment, nuclear facilities or systems, aircraft, aircraft devices, aircraft/emergency communication devices or other critical systems whose failure to perform be reasonably expected to result in significant injury or loss of life or catastrophic property damage. Accordingly, Supermicro disclaims any and all liability, and should buyer use or sell such products for use in such ultra-hazardous applications, it does so entirely at its own risk. Furthermore, buyer agrees to fully indemnify, defend and hold Supermicro harmless for and against any and all claims, demands, actions, litigation, and proceedings of any kind arising out of or related to such ultra-hazardous use or sale.