

SUPER<sup>®</sup>

SUPER<sup>®</sup>C2SEA

SUPER<sup>®</sup>C2SEE

## USER'S MANUAL

Revision 1.0c

---

The information in this User's Manual has been carefully reviewed and is believed to be accurate. The vendor assumes no responsibility for any inaccuracies that may be contained in this document, makes no commitment to update or to keep current the information in this manual, or to notify any person or organization of the updates. **Please Note: For the most up-to-date version of this manual, please see our web site at [www.supermicro.com](http://www.supermicro.com).**

Super Micro Computer, Inc. ("Supermicro") reserves the right to make changes to the product described in this manual at any time and without notice. This product, including software, if any, and documentation may not, in whole or in part, be copied, photocopied, reproduced, translated or reduced to any medium or machine without prior written consent.

IN NO EVENT WILL SUPER MICRO COMPUTER, INC. BE LIABLE FOR DIRECT, INDIRECT, SPECIAL, INCIDENTAL, SPECULATIVE OR CONSEQUENTIAL DAMAGES ARISING FROM THE USE OR INABILITY TO USE THIS PRODUCT OR DOCUMENTATION, EVEN IF ADVISED OF THE POSSIBILITY OF SUCH DAMAGES. IN PARTICULAR, SUPER MICRO COMPUTER, INC. SHALL NOT HAVE LIABILITY FOR ANY HARDWARE, SOFTWARE, OR DATA STORED OR USED WITH THE PRODUCT, INCLUDING THE COSTS OF REPAIRING, REPLACING, INTEGRATING, INSTALLING OR RECOVERING SUCH HARDWARE, SOFTWARE, OR DATA.

Any disputes arising between manufacturer and customer shall be governed by the laws of Santa Clara County in the State of California, USA. The State of California, County of Santa Clara shall be the exclusive venue for the resolution of any such disputes. Supermicro's total liability for all claims will not exceed the price paid for the hardware product.

---

California Best Management Practices Regulations for Perchlorate Materials: This Perchlorate warning applies only to products containing CR (Manganese Dioxide) Lithium coin cells. "Perchlorate Material-special handling may apply. See [www.dtsc.ca.gov/hazardouswaste/perchlorate](http://www.dtsc.ca.gov/hazardouswaste/perchlorate)"

---

This equipment has been tested and found to comply with the limits for a Class B digital device pursuant to Part 15 of the FCC Rules. These limits are designed to provide reasonable protection against harmful interference in a residential installation. This equipment generates, uses, and can radiate radio frequency energy and, if not installed and used in accordance with the manufacturer's instruction manual, may cause interference with radio communications. However, there is no guarantee that interference will not occur in a particular installation. If this equipment does cause harmful interference to radio or television reception, which can be determined by turning the equipment off and on, you are encouraged to try to correct the interference by one or more of the following measures:

- Reorient or relocate the receiving antenna.
- Increase the separation between the equipment and the receiver.
- Connect the equipment into an outlet on a circuit different from that to which the receiver is connected.
- Consult the dealer or an experienced radio/television technician for help.

**WARNING: Handling of lead solder materials used in this product may expose you to lead, a chemical known to the State of California to cause birth defects and other reproductive harm.**

Manual Revision: Rev. 1.0c

Release Date: July 20, 2009

Unless you request and receive written permission from Super Micro Computer, Inc., you may not copy any part of this document.

Information in this document is subject to change without notice. Other products and companies referred to herein are trademarks or registered trademarks of their respective companies or mark holders.

Copyright © 2009 by Super Micro Computer, Inc.  
All rights reserved.

**Printed in the United States of America**

---

---

## Preface

This manual is written for system integrators, PC technician and knowledgeable PC users. It provides information for the installation and use of the **SUPER** C2SEA/C2SEE motherboard.

### About this Motherboard

The C2SEA/C2SEE supports single Core™ 2 Extreme/Core™ 2 Quad/Core™ 2 Duo Processor with a system bus speed of 1333 MHz/1066 MHz/800 MHz. The Intel® Core™ 2 Extreme/Core™ 2 Quad/Core™ 2 Duo Processor supports the 775-Land Grid Array Package that interfaces with the motherboard via an LGA775 socket. With support of Quad-Core/Dual-Core Technology, Wide Dynamic Execution, FSB Dynamic Bus Inversion (DBI), Advanced Digital Media Boost, Smart Memory Access, and Thermal Management 2 (TM2), the C2SEA/C2SEE delivers unparalleled system performance and great power efficiency for desktop systems. Please refer to the motherboard specifications pages on our web site (<http://www.supermicro.com/Products/>) for updates on supported processors. This product is intended to be installed and serviced by a professional technician.

### Manual Organization

**Chapter 1** describes features, specifications and detailed information about the motherboard and the chipset. **Chapter 2** provides hardware installation instructions. Read this chapter when installing the processor, memory modules and other hardware components into the system.

**Chapter 3** describes troubleshooting procedures for the video, the memory and the system setup stored in CMOS if you encounter problems.

**Chapter 4** includes an introduction to BIOS and provides detailed information on running the CMOS Setup utility.

**Appendix A** and **Appendix B** list BIOS POST Error Codes and Messages. **Appendix C** provides Software Installation Instructions. **Appendix D** describes the BIOS Recovery procedure.

### Conventions Used in the Manual:

Pay attention to the following symbols for proper installation and to prevent damage to the motherboard components or injury to yourself:



**Warning:** Important information given to ensure proper system installation, to prevent bodily injury or damage to the components.



**Note:** Additional Information given to differentiate various models or to ensure correct system setup.

## Contacting Supermicro

### Headquarters

Address: Super Micro Computer, Inc.  
980 Rock Ave.  
San Jose, CA 95131 U.S.A.

Tel: +1 (408) 503-8000

Fax: +1 (408) 503-8008

Email: [marketing@supermicro.com](mailto:marketing@supermicro.com) (General Information)  
[support@supermicro.com](mailto:support@supermicro.com) (Technical Support)

Web Site: [www.supermicro.com](http://www.supermicro.com)

### Europe

Address: Super Micro Computer B.V.  
Het Sterrenbeeld 28, 5215 ML  
's-Hertogenbosch, The Netherlands

Tel: +31 (0) 73-6400390

Fax: +31 (0) 73-6416525

Email: [sales@supermicro.nl](mailto:sales@supermicro.nl) (General Information)  
[support@supermicro.nl](mailto:support@supermicro.nl) (Technical Support)  
[rma@supermicro.nl](mailto:rma@supermicro.nl) (Customer Support)

### Asia-Pacific

Address: Super Micro Computer, Inc.  
4F, No. 232-1 Liancheng Road  
Chung-Ho 235, Taipei Hsien, Taiwan, R.O.C.

Tel: +886-(2) 8226-3990

Fax: +886-(2) 8226-3991

Web Site: [www.supermicro.com.tw](http://www.supermicro.com.tw)

Technical Support:

Email: [support@supermicro.com.tw](mailto:support@supermicro.com.tw)

Tel: 886-2-82261900

## Notes

# Table of Contents

## Preface

|                                      |     |
|--------------------------------------|-----|
| About This Manual .....              | iii |
| Manual Organization .....            | iii |
| Conventions Used in the Manual ..... | iii |

## Chapter 1: Introduction

|  |      |
|--|------|
| 1-1 Overview .....                                       | 1-1  |
| Checklist .....  | 1-1  |
| SUPER C2SEA/C2SEE Image .....                            | 1-2  |
| SUPER C2SEA/C2SEE Layout .....                           | 1-3  |
| SUPER C2SEA/C2SEE Quick Reference .....                  | 1-4  |
| Motherboard Features .....                               | 1-6  |
| Intel G45/G43 Express Chipset: System Block Diagram..... | 1-8  |
| 1-2 Chipset Overview .....                               | 1-9  |
| 1-3 Recovery from AC Power Loss .....                    | 1-10 |
| 1-4 PC Health Monitoring .....                           | 1-10 |
| 1-5 ACPI Features.....                                   | 1-10 |
| 1-6 Power Supply .....                                   | 1-11 |
| 1-7 Versatile Media Capabilities.....                    | 1-12 |
| 1-8 Super I/O .....                                      | 1-12 |

## Chapter 2: Installation

|   |      |
|---|------|
| 2-1 Static-Sensitive Devices .....            | 2-1  |
| 2-2 Motherboard Installation .....            | 2-2  |
| 2-3 Processor and Heatsink Installation ..... | 2-3  |
| 2-4 Installing DIMMs .....                    | 2-7  |
| 2-5 Control Panel Connectors/IO Ports .....   | 2-9  |
| 1. Back Panel Connectors/IO Ports.....        | 2-9  |
| 2. Front Control Panel .....                  | 2-10 |
| 3. Front Control Panel Pin Definitions .....  | 2-11 |
| Power LED .....                               | 2-11 |
| HDD LED.....                                  | 2-11 |
| NIC1 LED Indicators .....                     | 2-12 |
| OH/Fan Fail LED .....                         | 2-12 |
| Reset Button.....                             | 2-13 |
| Power Button.....                             | 2-13 |

---

|  |      |
|--|------|
| 2-6 Connecting Cables .....                  | 2-14 |
| ATX/Auxiliary Power Connectors .....         | 2-14 |
| Universal Serial Bus (USB) .....             | 2-15 |
| GLAN1 Port .....                             | 2-15 |
| Overheat LED/Fan Fail LED .....              | 2-16 |
| Chassis Intrusion .....                      | 2-16 |
| Fan Headers .....                            | 2-17 |
| VGA Connector .....                          | 2-17 |
| ATX PS/2 Keyboard and PS/2 Mouse Ports ..... | 2-18 |
| Serial Ports .....                           | 2-18 |
| Wake-On-Ring .....                           | 2-19 |
| Wake-On-LAN .....                            | 2-19 |
| High-Definition Audio (HDA) .....            | 2-20 |
| Front Panel Audio Header .....               | 2-21 |
| CD Header .....                              | 2-21 |
| S/PDIF_Out Connector .....                   | 2-22 |
| HDMI Connector .....                         | 2-22 |
| 1394_1/1394_2 Connections .....              | 2-23 |
| Power LED .....                              | 2-23 |
| 2-7 Jumper Settings .....                    | 2-24 |
| Explanation of Jumpers .....                 | 2-24 |
| GLAN Enable/Disable .....                    | 2-24 |
| Watch Dog Enable .....                       | 2-25 |
| IEEE 1394a Enable .....                      | 2-25 |
| PCI/PCI-Exp. Slots to SMB Speeds .....       | 2-26 |
| Clear CMOS .....                             | 2-26 |
| IDE Enable/Disable .....                     | 2-27 |
| Audio Enable .....                           | 2-27 |
| USB Wake-up .....                            | 2-28 |
| Onboard Speaker Enable .....                 | 2-29 |
| 2-8 Onboard Indicators .....                 | 2-30 |
| GLAN LED Indicators .....                    | 2-30 |
| Power LED .....                              | 2-31 |
| 2-9 Parallel Port and IDE Connections .....  | 2-32 |
| Parallel Port Connector .....                | 2-32 |
| IDE Connector .....                          | 2-33 |

## **Chapter 3: Troubleshooting**

|                                      |     |
|--------------------------------------|-----|
| 3-1 Troubleshooting Procedures ..... | 3-1 |
| Before Power On .....                | 3-1 |

---

|   |     |
|---|-----|
| No Power.....                                 | 3-1 |
| No Video .....                                | 3-2 |
| Memory Errors.....                            | 3-2 |
| Losing the System's Setup Configuration ..... | 3-2 |
| 3-2 Technical Support Procedures .....        | 3-3 |
| 3-3 Frequently Asked Questions .....          | 3-3 |
| 3-4 Returning Merchandise for Service .....   | 3-6 |

## **Chapter 4: BIOS**

|                           |      |
|---------------------------|------|
| 4-1 Introduction .....    | 4-1  |
| 4-2 Main BIOS Setup ..... | 4-2  |
| 4-3 Advanced Setup.....   | 4-4  |
| 4-4 Security Setup.....   | 4-18 |
| 4-5 Boot Settings.....    | 4-19 |
| 4-6 Exit .....            | 4-20 |

## **Appendices:**

|   |     |
|---|-----|
| Appendix A: BIOS POST Error Codes .....                   | A-1 |
| Appendix B: AMI BIOS POST Messages.....                   | B-1 |
| Appendix C: Installing Software Programs and Drivers..... | C-1 |
| Appendix D: BIOS Recovery .....                           | D-1 |



# Chapter 1

## Introduction

### 1-1 Overview

#### Checklist

Congratulations on purchasing your computer motherboard from an acknowledged leader in the industry. Supermicro boards are designed with the utmost attention to detail to provide you with the highest standards in quality and performance.

Please check that the following items have all been included with your motherboard. If anything listed here is damaged or missing, contact your retailer.

All the following items are included in the retail box only:

One (1) Supermicro Mainboard

Two (2) SATA cables (CBL-0044L)

One (1) IDE hard drive cable (CBL-0036L-3) (C2SEA only)

One (1) IO Shield (MCP-260-00021-0N)

One (1) Supermicro CD containing drivers and utilities

One (1) User's/BIOS Manual

## SUPER C2SEA Motherboard Image

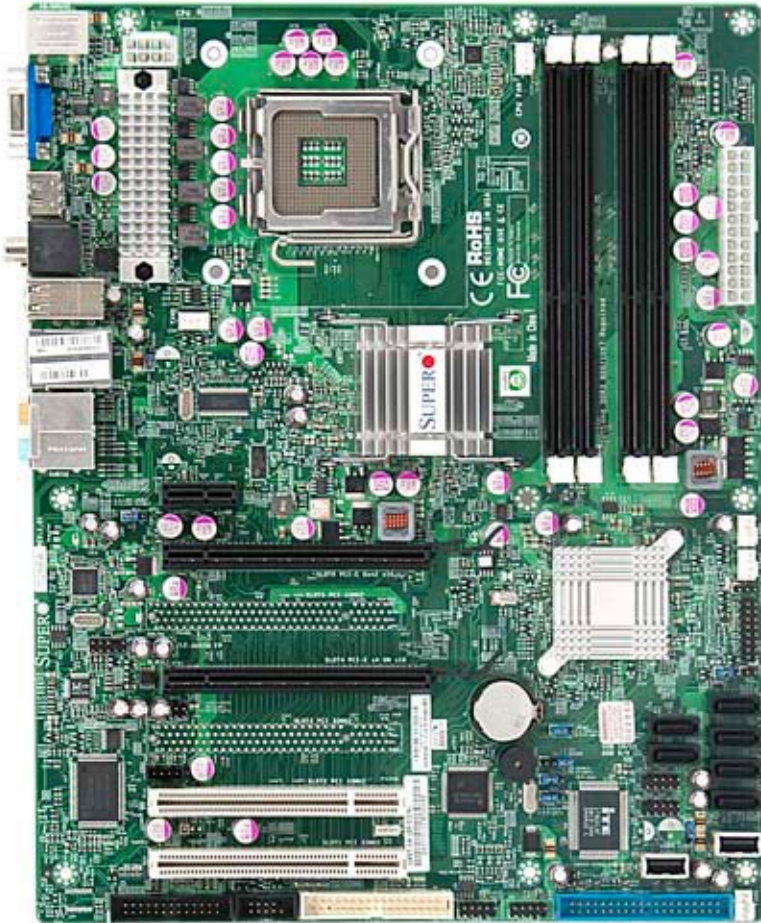

**Note:** All pictures and drawings shown in this manual were based upon the latest PCB Revision available at the time of publishing of the manual. The motherboard you have received may or may not look exactly the same as those in this manual.

## Motherboard Layout

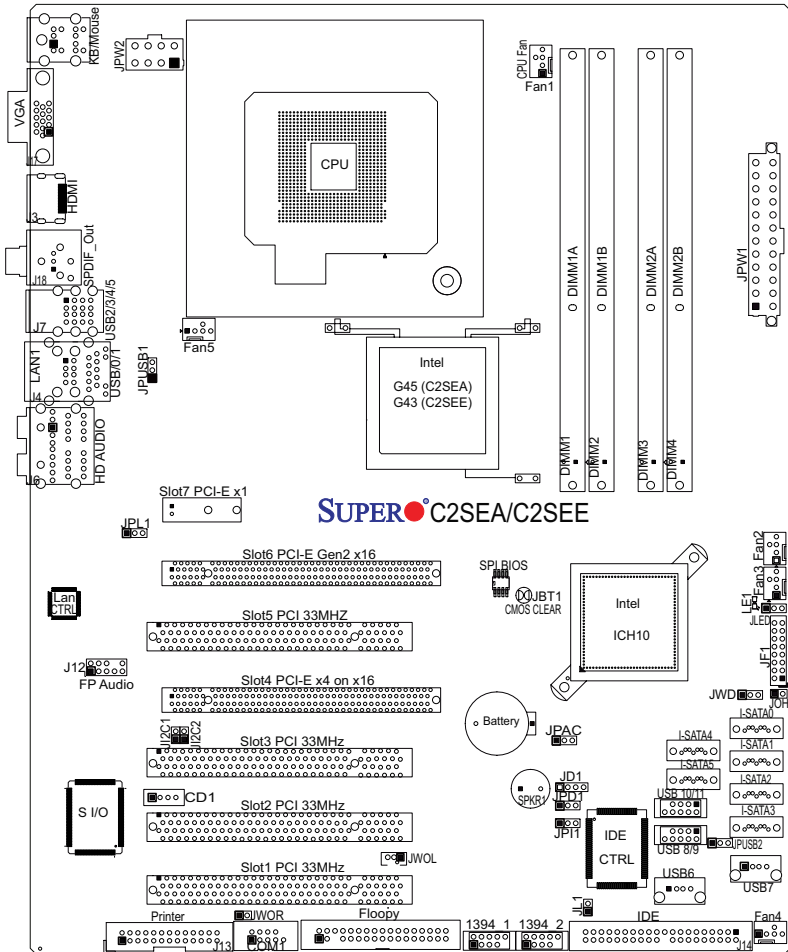
**Important Notes to the User**

- Jumpers not indicated are for testing only.
- See Chapter 2 for detailed information on jumpers, I/O ports and JF1 front panel connections.
- "■" indicates the location of Pin 1.

| Differences between the C2SEA and C2SEE Models |                           |                          |
|--|---------------------------|--------------------------|
|  | C2SEA                     | C2SEE                    |
| Chipset  | Intel G45                 | Intel G43                |
| Memory   | DDR3 in four DIMM Sockets | DDR3 in two DIMM Sockets |
| PCI 33 MHz slots                               | Two (Slots 1/2)           | Four (Slots 1/2/3/5)     |
| IDE/IDE CTRL                                   | One socket, two devices   | Not available            |
| 1394a Connections                              | 1394_1, 1394_2 headers    | Not available            |
| HDMI   | One Connector             | Not available            |

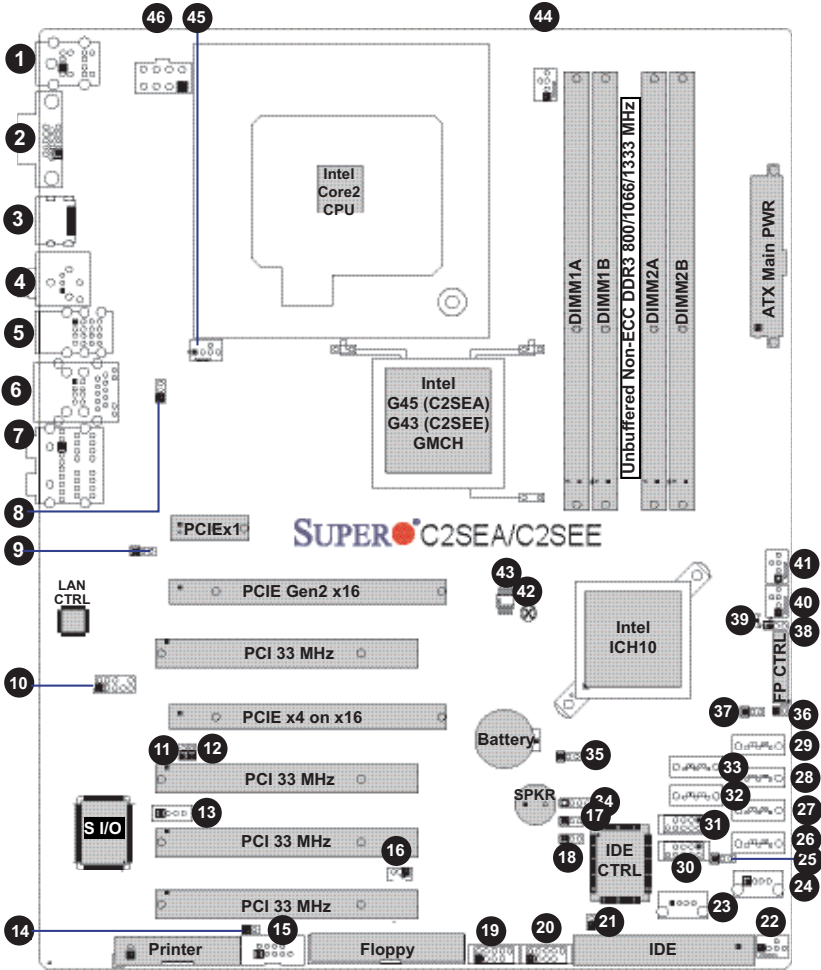

### SUPER<sup>®</sup> C2SEA/C2SEE Quick Reference

| <u>Jumper</u>                       | <u>Label</u> | <u>Description</u>      | <u>Default Setting</u> |
|-------------------------------------|--------------|-------------------------|------------------------|
| JBT1                                | 41           | CMOS Clear              | See Chapter 2          |
| JD1                                 | 34           | Onboard Speaker Enable  | Pins 3-4 (Enabled)     |
| J <sup>1</sup> C1/J <sup>1</sup> C2 | 11/12        | SMB to PCI Slots        | Open (Disabled)        |
| JPI1 (C2SEA)                        | 18           | 1394_1/ 1394_2 Enable   | Pins 1-2 (Enabled)     |
| JPAC                                | 35           | Audio Enable            | Pins 1-2 (Enabled)     |
| JPD1 (C2SEA)                        | 17           | IDE Enable              | Pins 1-2 (Enabled)     |
| JPL1                                | 9            | Gigabit LAN 1 Enable    | Pins 1-2 (Enabled)     |
| JPUS1/JPUSB2                        | 8/25         | USB 2-5/USB 6-11 Enable | Pins 1-2 (Disabled)    |
| JWD                                 | 37           | Watch Dog Timer Out     | Pins 1-2 (Reset)       |

| <b><u>Connector</u></b>             | <b><u>Label</u></b>          | <b><u>Description</u></b>  |
|-------------------------------------|------------------------------|--|
| 1394_1, 1394_2                      | 19/20                        | 1394_1 and 1394_2 Headers (C2SEA)  |
| Audio, CD1, FP<br>Audio, S/PDIF_Out | 7, 13,<br>10, 4              | Audio: Backplane HD Audio Header, CD1: Audio<br>CD Input, FP Audio: FP Audio, S/PDIF_Out<br>Header |
| COM 1                               | 15                           | COM Port 1   |
| Fans 1-5                            | 44, 41,<br>40, 22,<br>45     | Fan 1: CPU Fan, Fans 2~5: Chassis/System Fans  |
| HDMI                                | 3                            | High-Definition Multimedia (Audio/Video) Interface<br>Connector (C2SEA)                            |
| JF1                                 |                              | FP Control Panel Header  |
| JL1                                 | 21                           | Chassis Intrusion Header   |
| JLED                                | 38                           | Onboard Power LED Indicator  |
| JPW1, JPW2                          |                              | ATX 24-Pin Power and 12V 8-Pin Power Connec-<br>tors   |
| JOH                                 | 36                           | Overheat LED   |
| JWOL                                | 16                           | Wake-on-LAN Header   |
| JWOR                                | 14                           | Wake-On Ring Header  |
| Printer                             |                              | Printer (Parallel) Header  |
| LAN1                                |                              | Ethernet RJ45 (Gigabit LAN) Connector  |
| SATA 0-5                            | 29, 28,<br>27, 26,<br>33, 32 | SATA Headers 0~5   |
| SPKR1                               |                              | Internal Buzzer  |
| USB 0~1, 2~5                        | 6, 5                         | Back Panel Universal Serial Ports  |
| USB 6, 7, 8~9,<br>10~11             | 23, 24,<br>30, 31            | Front Panel Accessible USB Headers   |
| VGA                                 | 2                            | Video Graphics Connector   |
| <b><u>LED Indicator</u></b>         | <b><u>Label</u></b>          | <b><u>Description</u></b>  |
| LE1                                 | 39                           | Standby Power LED Indicator  |



**Note:** IDE, 1394a and HDMI connections are available on C2SEA only.

## Motherboard Features

### Processor

- Single Intel Core™ 2 Extreme/Quad/Duo processor with an FSB of 1333/1066/800 MHz

### Memory

- Up to 8GB of Unbuffered non-ECC DDR3@1333/1066/800 memory for single-channel or dual-channel interleaved mode in four DIMM sockets (C2SEA)
- Up to 4GB of Unbuffered non-ECC DDR3@1333/1066/800 memory for single-channel or dual-channel interleaved mode in two DIMM sockets (C2SEE)

### Chipset

- Intel G45 GMCH (C2SEA) or G43 GMCH (C2SEE)
- ICH10

### Expansion Slots

- One (1) PCI-Express (2.0) x16 (Slot6)
- One (1) PCI-Express x4 (x16 physical slot) (Slot4)
- One (1) PCI-Express x1 (Slot7)
- Two (2) 32-bit PCI 33MHz (Slot1, Slot2) (C2SEA)
- Four (4) 32-bit PCI 33MHz (Slot1, Slot2, Slot3, and Slot5) (C2SEE)

### BIOS

- 8 Mb Firmware SPI AMI Flash BIOS
- DMI 2.3, PCI 2.3, ACPI 1.0/2.0/3.0, SMBIOS 2.5, Plug and Play (PnP), and USB Keyboard support

### PC Health Monitoring

- Onboard voltage monitors for CPU Core Voltage, Memory Voltage, +1.5V, +3.3V, +5V, +5V standby, ±12V, Vbat (battery voltage), and Hyper-Threading.
- Fan status monitor with firmware 4 pin fan speed control
- 4-Phase CPU switching voltage regulator
- SuperDoctor III, Watch Dog, NMI
- Power-up mode control for recovery from AC power loss
- CPU/System overheat LED and control
- System resource alert via Super Doctor III
- Auto-switching voltage regulator for the CPU core
- CPU Thermal Trip support
- Thermal Management 2 (TM2) support

**ACPI Features**

- Slow blinking LED for suspend state indicator
- BIOS support for USB keyboard
- Main switch override mechanism
- External modem ring-on

**Onboard I/O**

- Built in ICH10 SATA Controller, 6 connectors for up to 6 devices
- One fast UART 16550 compatible serial port
- Realtek RTL8111C Gigabit Ethernet controllers
- PS/2 mouse and PS/2 keyboard ports
- ITE 8213F Controller supports one IDE channel & two devices (C2SEA only)
- 12 USB (Universal Serial Bus) 2.0 ports
- Realtek ALC 888 High-Definition Audio (HDA) codecs supports 10 DAC Channels
- Built-in GMCH and onboard VGA Connector
- High-Definition Multimedia Interface (HDMI) Connector (C2SEA only)
- Two IEEE 1394a Headers (C2SEA only)

**Other**

- Wake-on-LAN (WOL)
- Wake-on-Ring (WOR)
- Suspend-to-RAM
- Onboard +5V Standby Power Warning LED ("LE1")

**CD Utilities**

- BIOS flash upgrade utility
- Drivers and software for Intel G45/G43 Express chipset utilities

**Dimensions**

- ATX form factor, 12.0" x 9.6" (304.8 x 243.8 mm)

## Block Diagram

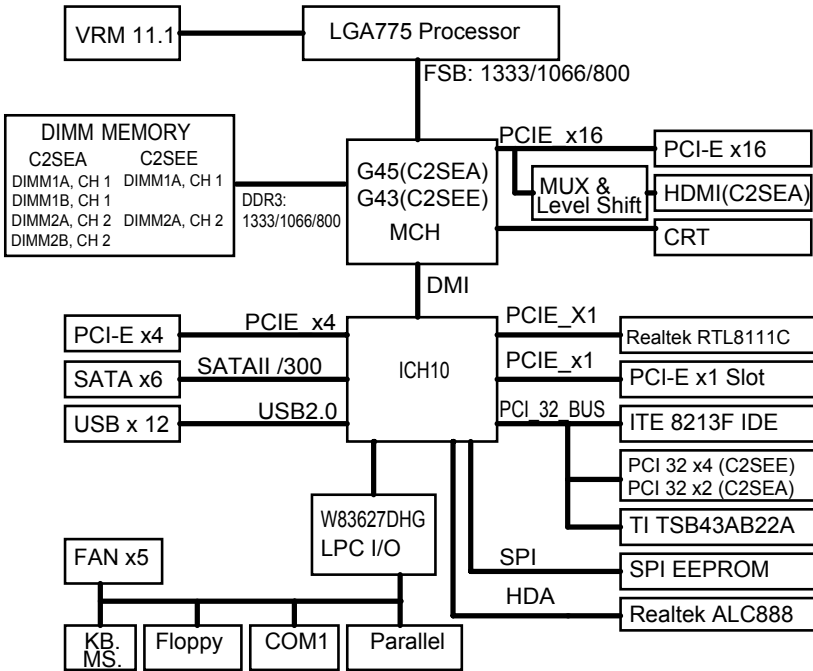

### C2SEA/C2SEE System Block Diagram



**Note:** This is a general block diagram and may not exactly represent the features on your motherboard. See the following pages for the actual specifications of each motherboard.



## 1-2 Chipset Overview

The Intel G45/G43 Express Chipset is specially designed for use with Intel Core™ 2 Extreme/Core Quad/Core Duo LGA 775 processors. It consists of two primary components: the Graphics and Memory Controller Hub (GMCH), and the I/O Controller Hub (ICH10). The GMCH manages the data flow between the CPU interface, the System Memory interface, the External Graphics interface (or PCI-Express Interface), and the I/O Controller through the Direct Media Interface (DMI). The ICH10 provides a multitude of I/O related functions.

### **Graphics and Memory Controller Hub (GMCH)**

Utilizing a single LGA 775 socket processor, the G45/G43 GMCH supports an FSB frequency of 1333/1066/800 MHz. Host-initiated I/O cycles are decoded to the PCI-Express, the DMI, or the GMCH configuration space. Host-initiated memory cycles are decoded to PCI-Express, DMI or system memory. Memory accesses initiated from PCI-Express will be snooped on the host bus between DMI to system SDRAM. The GMCH supports one or two channels of DDR3 controller with a maximum of two DIMMs per channel.

### **Direct Media Interface (DMI)**

Providing the high-speed, chip-to-chip connection between the GMCH and ICH10 is the Direct Media Interface (DMI). The DMI integrates advanced priority-based servicing, allowing for concurrent traffic, true isochronous transfer capabilities and permitting current as well as legacy software to work normally.

### **Intel ICH10 System Features**

The Intel I/O Controller Hub (ICH10) supports a variety of I/O related functions and PCI devices, including the following:

- DMI-to PCI Bridge
- LPC Controller
- SATA Controllers #1 and #2
- Thermal Subsystem
- SMBus Controller
- Six FS/LS USB UHCI Controllers
- Two HS USB EHCI Controllers

## 1-3 Recovery from AC Power Loss

BIOS provides a setting for you to determine how the system will respond when AC power is lost and then restored to the system. You can choose for the system to remain powered off (in which case you must hit the power switch to turn it back on) or for it to automatically return to a power on state. See the Power Lost Control setting in the BIOS chapter of this manual to change this setting. The default setting is **Power-Off**.

## 1-4 PC Health Monitoring

This section describes the PC health monitoring features of the C2SEA/C2SEE. The motherboard has an onboard System Hardware Monitor chip that supports PC health monitoring.

The onboard voltage monitor will scan the Onboard Voltage Monitors for the CPU Core, Memory +1.5V, +3.3V, +5V standby, +5V, Vbat and  $\pm 12V$  continuously. Once a voltage becomes unstable, it will give a warning or send an error message to the screen. Users can adjust the voltage thresholds to define the sensitivity of the voltage monitor by using SuperO Doctor III.

## 1-5 ACPI Features

ACPI stands for Advanced Configuration and Power Interface. The ACPI specification defines a flexible and abstract hardware interface that provides a standard to integrate power management features throughout a PC system, including its hardware, operating system and application software. This enables the system to automatically turn on and off peripherals such as CD-ROMs, network cards, hard disk drives and printers. This also includes consumer devices connected to the PC such as VCRs, TVs, telephones and stereos.

In addition to enabling operating system-directed power management, ACPI provides a generic system event mechanism for Plug and Play and an operating-system-independent interface for configuration control. ACPI leverages the Plug and Play BIOS data structures while providing a processor architecture-independent implementation that is compatible with Windows 2000, Windows XP, Windows 2003, Windows 2003 Servers.

### Enhanced Power Management

The onboard ICH10 chip provides advanced power management functions that will greatly improve the performance of various low-power (suspend) states and enhance clock control. A hardware-based component provides software-independent thermal management that is compatible with the ACPI Revision 3.0a.

## Slow Blinking LED for Suspend-State Indicator

When the CPU goes into a suspend state, the chassis power LED will start blinking to indicate that the CPU is in suspend mode. When the user presses any key, the CPU will wake-up and the LED will automatically stop blinking and remain on.

## BIOS Support for USB Keyboard

If the USB keyboard is the only keyboard in the system, it will function like a normal keyboard during system boot-up.

## Wake-On-LAN (WOL)

Wake-On-LAN is defined as the ability of a management application to remotely power up a computer that is powered off. Remote PC setup, up-dates and asset tracking can occur after hours and on weekends so that daily LAN traffic is kept to a minimum and users are not interrupted. The motherboard has a 3-pin header (WOL) to connect to the 3-pin header on a Network Interface Card (NIC) that has WOL capability. In addition, an onboard LAN controller can also support WOL without any connection to the WOL header. The 3-pin WOL header is to be used with a LAN add-on card only.



**Note:** Wake-On-LAN requires an ATX 2.01 (or above) compliant power supply.

## 1-6 Power Supply

As with all computer products, a stable power source is necessary for proper and reliable operation. It is even more important for processors that have high CPU clock rates of 1 GHz and faster.

The **SUPER** C2SEA/C2SEE accommodates 12V ATX power supplies. Although most power supplies generally meet the specifications required by the CPU, some are inadequate. A 2A of current supply on a 5V Standby rail is strongly recommended.

It is strongly recommended that you use a high quality power supply that meets 12V ATX power supply Specification 1.1 or above. It is also required that the 12V 8-pin power connection be used for the system to work properly. In areas where noisy power transmission is present, you may choose to install a line filter to shield the computer from noise. It is recommended that you also install a power surge protector to help avoid problems caused by power surges.

## 1-7 Versatile Media Capabilities

### High-Definition Audio and HDMI Connections

The High-Definition Audio Controller, embedded in the ICH10, delivers up to four codecs, supporting different types of codecs. Operating at 3.3V or 1.5V, the embedded Audio Controller supports a multi-channel audio stream, 32-bit sample depth, up to 192 kHz of same rate, and can be used with a variety of microphones for input. In addition to the HD Audio connection, the C2SEA also includes a High-Definition Multimedia Interface (HDMI) connector on the motherboard. This connector transmits digital signals, providing superb multimedia interface support. With these versatile audio and video capabilities built in, this motherboard provides the user with a state of the art audio/video experience that is larger than life.

### I/O Virtualization Technology (VT-d)

With the Intel ICH10 built in, the C2SEA/C2SEE supports I/O Virtualization Technology (VT-d) that enables multiple operating systems and applications to run in independent partitions. Each partition uses its own subset of host physical memory, and behaves like a virtual machine (VM), providing isolation and protection across multiple partitions. This feature is available when a processor that supports the virtualization of platforms is installed on the motherboard.

## 1-8 Super I/O

The disk drive adapter functions of the Super I/O chip include a data separator, write pre-compensation circuitry, decode logic, data rate selection, a clock generator, drive interface control logic and interrupt and DMA logic. The wide range of functions integrated onto the Super I/O greatly reduces the number of components required for interfacing with floppy disk drives. The Super I/O supports two 360 K, 720 K, 1.2 M, 1.44 M or 2.88 M disk drives and data transfer rates of 250 Kb/s, 500 Kb/s or 1 Mb/s.

It also provides two high-speed, 16550 compatible serial communication ports (UARTs). Each UART includes a 16-byte send/receive FIFO, a programmable baud rate generator, complete modem control capability and a processor interrupt system. Both UARTs provide legacy speed with baud rate of up to 115.2 Kbps as well as an advanced speed with baud rates of 250 K, 500 K, or 1 Mb/s, which support higher speed modems.

The Super I/O provides functions that comply with the ACPI (Advanced Configuration and Power Interface), which includes support of legacy and ACPI power management through a SMI or SCI function pin. It also features auto power management to reduce power consumption.

## Chapter 2

# Installation

### 2-1 Static-Sensitive Devices

Electro-static Discharge (ESD) can damage electronic components. To prevent damage to your system board, it is important to handle it very carefully. The following measures are generally sufficient to protect your equipment from ESD.

#### Precautions

- Use a grounded wrist strap designed to prevent static discharge.
- Touch a grounded metal object before removing the board from the antistatic bag.
- Handle the board by its edges only; do not touch its components, peripheral chips, memory modules or gold contacts.
- When handling chips or modules, avoid touching their pins.
- Put the motherboard and peripherals back into their antistatic bags when not in use.
- For grounding purposes, make sure your computer chassis provides excellent conductivity between the power supply, the case, the mounting fasteners and the motherboard.
- Use only the correct type of onboard CMOS battery as specified by the manufacturer. Do not install the onboard battery upside down to avoid possible explosion.

#### Unpacking

The motherboard is shipped in antistatic packaging to avoid static damage. When unpacking the board, make sure the person handling it is static protected.

## 2-2 Motherboard Installation

All motherboards have standard mounting holes to fit different types of chassis. Make sure that the locations of all the mounting holes for both motherboard and chassis match. Although a chassis may have both plastic and metal mounting fasteners, metal ones are highly recommended because they ground the motherboard to the chassis. Make sure that the metal standoffs click in or are screwed in tightly. Then use a screwdriver to secure the motherboard onto the motherboard tray. **Note:** Some components are very close to the mounting holes. Please take precautionary measures to prevent damage to these components when installing the motherboard to the chassis.

### Tools Needed

1. Philip Screwdriver

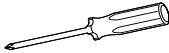

2. Pan head #6 screws (9 pcs)

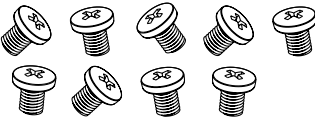

### Installation Instructions

1. Locate the mounting holes on the motherboard. Refer to the layout on the right for mounting hole locations.
2. Locate the matching mounting holes on the chassis. Align the mounting holes on the motherboard against the mounting holes on the chassis.
3. Place Standoffs on the chassis as needed.
4. Insert a Pan head #6 screw into a mounting hole on the motherboard and its matching mounting hole on the chassis, using a Philip screwdriver.
5. Repeat Step 4 to insert #6 screws to all mounting holes.
6. Make sure that the motherboard is securely placed on the chassis.

### Locations of Mounting Holes

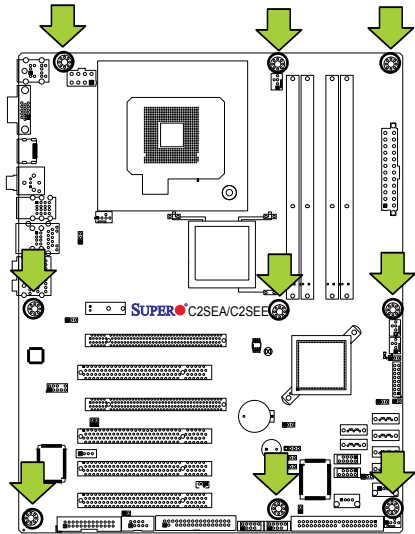

**Caution:** To prevent damage to the motherboard or its components, please do not use a force greater than 8 lb/inch on each mounting screw when installing the motherboard.

## 2-3 Processor and Heatsink Installation



**Warning:** When handling the processor package, avoid placing direct pressure on the label area of the fan.



### Notes:

1. Always connect the power cord last and always remove it before adding, removing or changing any hardware components. Make sure that you install the processor into the CPU LGA 775 socket before you install the CPU heatsink.
2. The Intel LGA 775 Processor package contains the CPU fan and heat-sink assembly. If you buy a CPU separately, make sure that you use only Intel-certified multi-directional heatsink and fan.
4. Make sure to install the motherboard into the chassis before you install the CPU heatsink and fan.
5. When receiving a motherboard with an LGA 775 Processor pre-installed, make sure that the CPU plastic cap is in place and none of the CPU pins are bent; otherwise, contact the retailer immediately. Refer to the MB Features Section for more details on CPU support.

### Installing an LGA 775 Processor

1. Press the load lever to release the load plate, which covers the CPU socket, from its locking position.

PnP Cap on  
top of the  
Load Plate  
  
Load Lever

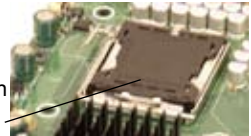

2. Gently lift the load lever to open the load plate.

Load Plate  
(with PnP Cap  
attached)



3. Use your thumb and your index finger to hold the CPU at the top center edge and the bottom center edge of the CPU.

4. Align CPU Pin1 (the CPU corner marked with a triangle) against the socket corner that is marked with a triangle cutout.

5. Align the CPU key that is the semi-circle cutout below a golden dot against the socket key, the Notch on the same side of the triangle cutout on the socket.

6. Once aligned, carefully lower the CPU straight down to the socket. (Do not drop the CPU on the socket. Do not move the CPU horizontally or vertically. Do not rub the CPU against the surface or against any pins of the socket to avoid damage to the CPU or the socket.)

7. With the CPU inside the socket, inspect the four corners of the CPU to make sure that the CPU is properly installed.

8. Use your thumb to gently push the load lever down to the lever lock.

9. If the CPU is properly installed into the socket, the plastic PnP cap will be automatically released from the load plate when the load lever is pushed in the lever lock. Remove the PnP cap from the motherboard.

 **Warning:** Please save the plastic PnP cap. The motherboard must be shipped with the PnP cap properly installed to protect the CPU socket pins. Shipment without the PnP cap properly installed will cause damage to the socket pins.



Top Center Edge  
Bottom Center Edge  
golden dot

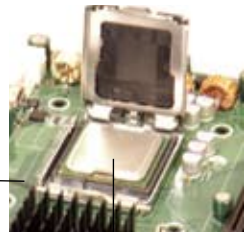
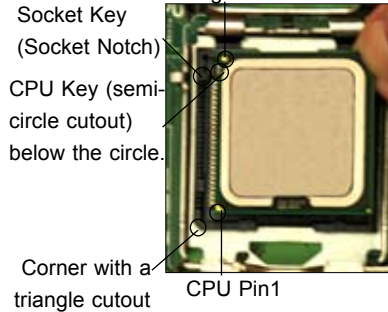

Load Lever  
CPU in the CPU socket



Plastic cap is released from the load plate if CPU properly installed.





## Installing the Heatsink

1. Locate the CPU Fan on the motherboard. (Refer to the layout on the right for the CPU Fan location.)
2. Position the heatsink in such a way that the heatsink fan wires are closest to the CPU fan and are not interfered with other components.
3. Inspect the CPU Fan wires to make sure that the wires are routed through the bottom of the heatsink.
4. Remove the thin layer of the protective film from the copper core of the heatsink.

 **Warning:** CPU overheating may occur if the protective film is not removed from the heatsink.

5. Apply the proper amount of thermal grease on the CPU.



**Note:** if your heatsink came with a thermal pad, please ignore this step.)

6. If necessary, rearrange the wires to make sure that the wires are not pinched between the heatsink and the CPU. Also make sure to keep clearance between the fan wires and the fins of the heatsink.

7. Align the four heatsink fasteners with the mounting holes on the motherboard. Gently push the pairs of diagonal fasteners (#1 & #2, and #3 & #4) into the mounting holes until you hear a click.



**Note:** Make sure to orient each fastener in a way that the narrow end of the groove is pointing outward.

Thermal Grease

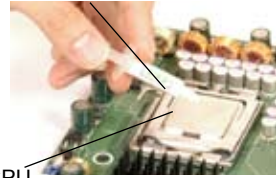

CPU

Fan Wires

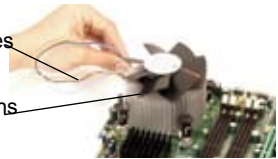

Heatsink Fins



Heatsink Fastener

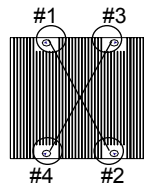

Narrow end of the groove points outward

8. Repeat Step 6 to insert all four heatsink fasteners into the mounting holes.
9. Once all four fasteners are securely inserted into the mounting holes and the heatsink is properly installed on the motherboard, connect the heatsink fan wires to the CPU Fan connector.

### **Removing the Heatsink**

1. Unplug the power cord from the power supply.
2. Disconnect the heatsink fan wires from the CPU fan header.
3. Use your finger tips to gently press on the fastener cap and turn it counterclockwise to make a 1/4 (90°) turn, and then pull the fastener upward to loosen it.
4. Repeat Step 3 to loosen all fasteners from the mounting holes.
5. With all fasteners loosened, remove the heatsink from the CPU.



---

## 2-4 Installing DIMMs



**Note:** Check the Supermicro web site for recommended memory modules.



**Warning:** Exercise extreme care when installing or removing DIMM modules to prevent any possible damage. Also note that the memory is interleaved to improve performance (see step 1).

### DIMM Installation

1. Insert the desired number of DIMMs into the memory slots, starting with DIMM1A, DIMM2A, then, DIMM1B and DIMM2B
2. Insert each DIMM module vertically into its slot. Pay attention to the notch along the bottom of the module to prevent inserting the DIMM module incorrectly.
3. Gently press down on the DIMM module until it snaps into place in the slot. Repeat for all modules (see step 1 above).

### Memory Support

The C2SEA motherboard supports up to 8 GB Unbuffered non-ECC DDR3@1333/1066/800 MHz in 4 DIMMs, and the C2SEE board supports up to 4 GB Unbuffered non-ECC DDR3@1333/1066/800 MHz in 2 DIMMs.

Populating DIMM1A, DIMM2A, and/or DIMM1B, DIMM2B with memory modules of the same size and of the same type will result in dual channel, two-way interleaved memory which is faster than the single channel, non-interleaved memory.



### Notes:

1. Due to the OS limitations, some operating systems may not show more than 4GB of memory.
2. Both Unbuffered ECC and non-ECC memory modules can be installed in the memory slots. However, the functionality of ECC is not supported by the chipset.
3. Due to memory allocation to system devices, memory remaining available for operational use will be reduced when 4 GB of RAM is used. The reduction in memory availability is disproportional. (Refer to the following Memory Availability Table for details.) For Microsoft Windows users: Microsoft implemented a design change in Windows XP with Service Pack 2 (SP2) and Windows Vista. This change is specific to the Physical Address Extension (PAE) mode behavior which improves driver compatibility. For more information, please read the following article at Microsoft's Knowledge Base website at: <http://support.microsoft.com/kb/888137>.

| Possible System Memory Allocation & Availability                   |        |  |
|--|--------|--|
| System Device  | Size   | Physical Memory Remaining (-Available)<br>(4 GB Total System Memory) |
| Firmware Hub flash memory (System BIOS)                            | 1 MB   | 3.99   |
| Local APIC   | 4 KB   | 3.99   |
| Area Reserved for the chipset                                      | 2 MB   | 3.99   |
| I/O APIC (4 Kbytes)  | 4 KB   | 3.99   |
| PCI Enumeration Area 1   | 256 MB | 3.76   |
| PCI Express (256 MB)   | 256 MB | 3.51   |
| PCI Enumeration Area 2 (if needed)<br>-Aligned on 256-MB boundary- | 512 MB | 3.01   |
| VGA Memory   | 16 MB  | 2.85   |
| TSEG   | 1 MB   | 2.84   |
| Memory available to OS and other applications                      |        | 2.84   |

### Installing and Removing DIMMs

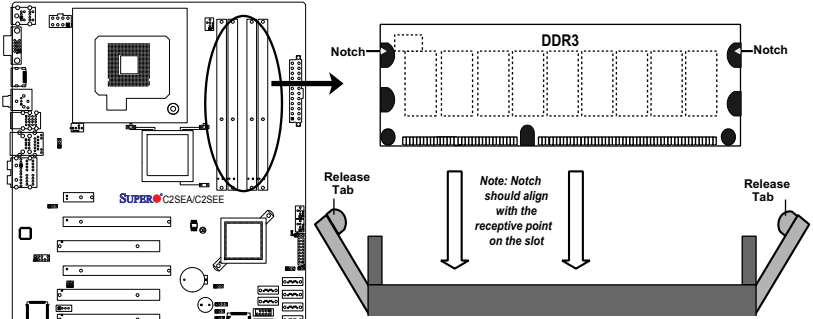

**To Install:** Insert module vertically and press down until it snaps into place. Pay attention to the alignment notch at the bottom.

**To Remove:**  
Use your thumbs to gently push the release tabs near both ends of the module. This should release it from the slot.

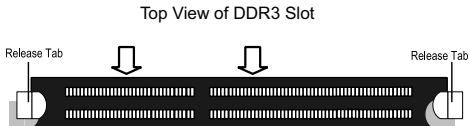

## 2-5 Control Panel Connectors/IO Ports

The I/O ports are color coded in conformance with the PC 99 specification. See The figure below for the colors and locations of the various I/O ports.

### 1. Back Panel Connectors/IO Ports

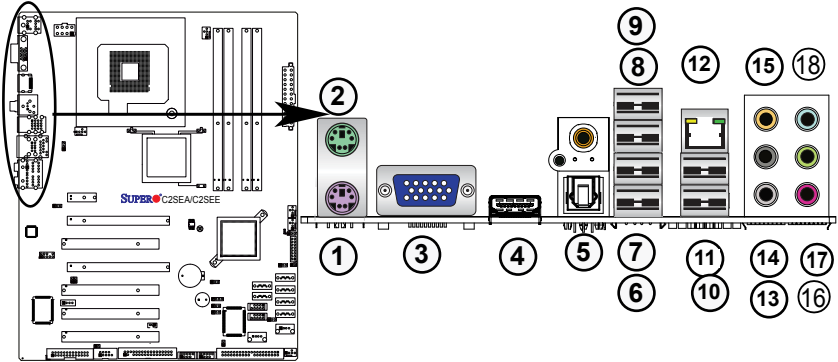

### Back Panel I/O Port Locations and Definitions

#### Back Panel Connectors

1. Keyboard (Purple)
2. PS/2 Mouse (Green)
3. VGA (Blue)
4. HDMI (C2SEA only)
5. S/PDIF\_Out
6. USB Port 2
7. USB Port 3
8. USB Port 4
9. USB Port 5
10. USB Port 0
11. USB Port 1
12. Gigabit LAN 1
13. Side Surround (Grey)
14. Back Surround (Black)
15. CEN/LFE (Orange)
16. Microphone-In (Pink)
17. Front (Green)
18. Line-In (Blue)

(See Section 2-5 for details.)

## 2. Front Control Panel

JF1 contains header pins for various buttons and indicators that are normally located on a control panel at the front of the chassis. These connectors are designed specifically for use with Supermicro server chassis. See Figure 2-4 for the descriptions of the various control panel buttons and LED indicators. Refer to the following section for descriptions and pin definitions.

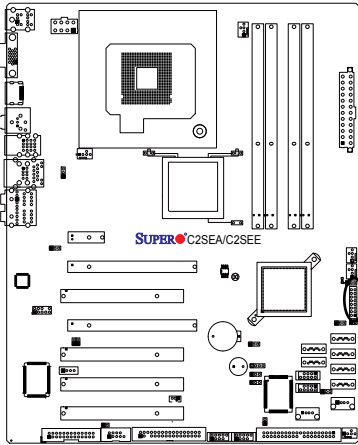

JF1 Header Pins

|                 | 16 | 15 |              |
|-----------------|----|----|--------------|
| Power LED       | ○  | ○  | LED_Anode+   |
| HDD LED         | ○  | ○  | LED_Anode+   |
| NIC1 LED        | ○  | ○  | LED_Anode+   |
| X               | ○  | ○  | LED_Anode+   |
| OH/Fan Fail LED | ○  | ○  | LED_Anode+   |
| X               | ○  | ○  | X            |
| Ground          | ○  | ○  | Reset Button |
| Ground          | ○  | ○  | Power Button |
|                 | 2  | 1  |              |

### 3. Front Control Panel Pin Definitions

#### Power LED

The Power LED connection is located on pins 15 and 16 of JF1. Refer to the table on the right for pin definitions.

| Power LED<br>Pin Definitions (JF1) |                |
|------------------------------------|----------------|
| Pin#                               | Definition     |
| 15                                 | LED_Anode+     |
| 16                                 | PWR LED Signal |

#### HDD LED

The HDD LED connection is located on pins 13 and 14 of JF1. Attach a hard drive LED cable here to display disk activity (for any hard drives on the system, including SAS and Serial ATA). See the table on the right for pin definitions.

| HDD LED<br>Pin Definitions (JF1) |            |
|----------------------------------|------------|
| Pin#                             | Definition |
| 13                               | LED_Anode+ |
| 14                               | HD Active  |

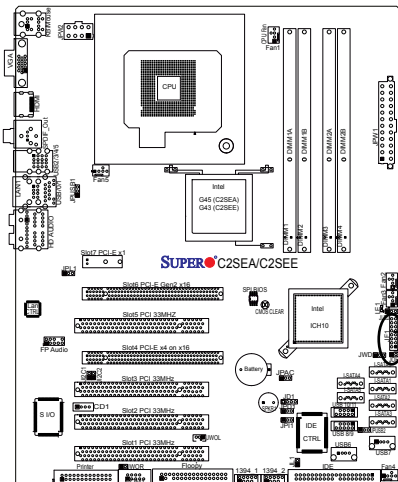

A. PWR LED connector

B. HDD LED connector

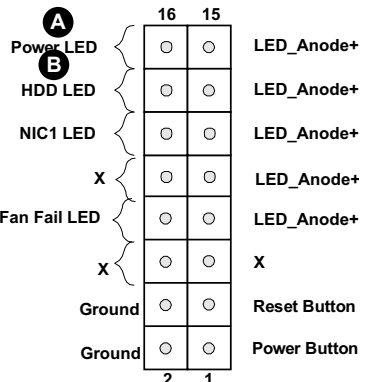

**NIC1 LED Indicators**

The NIC (Network Interface Controller) LED connection for GLAN port1 is located on pins 11 and 12 of JF1. Attach NIC LED cables to display network activity. Refer to the table on the right for pin definitions.

| GLAN1 LED Pin Definitions (JF1) |            |
|---------------------------------|------------|
| Pin#                            | Definition |
| 11                              | Vcc        |
| 12                              | Ground     |

**Overheat/Fan Fail LED (OH)**

Connect an LED cable to the OH/Fan Fail connection on pins 7 and 8 of JF1 to provide advanced warnings of chassis overheating or fan failure. Refer to the table on the right for pin definitions.

| OH/Fan Fail LED Pin Definitions (JF1) |                        |
|---------------------------------------|------------------------|
| Pin#                                  | Definition             |
| 7                                     | LED_Anode+             |
| 8                                     | OH/Fan Fail LED Signal |

| OH/Fan Fail Indicator Status |            |
|------------------------------|------------|
| State                        | Definition |
| Off                          | Normal     |
| On                           | Overheat   |
| Flashing                     | Fan Fail   |

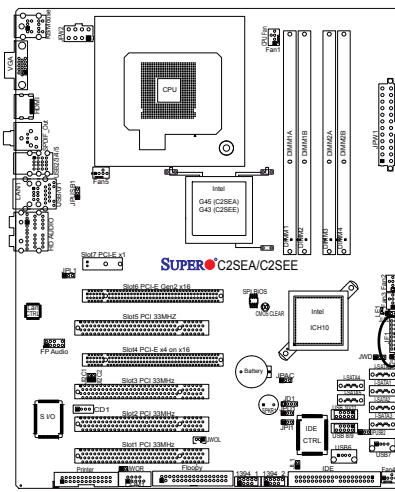

- A. NIC1 LED
- B. OH/Fan Fail LED

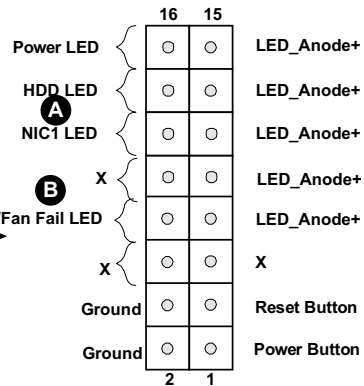



### Reset Button

The Reset Button connection is located on pins 3 and 4 of JF1. Attach it to a hardware reset switch on the computer case. Refer to the table on the right for pin definitions.

| Reset Button<br>Pin Definitions (JF1) |            |
|---------------------------------------|------------|
| Pin#                                  | Definition |
| 3                                     | Reset      |
| 4                                     | Ground     |

### Power Button

The Power Button connection is located on pins 1 and 2 of JF1. Momentarily contacting both pins will power on/off the system. This button can also be configured to function as a suspend button (with a setting in the BIOS - see Chapter 4). To turn off the power when set to suspend mode, press the button for at least 4 seconds. Refer to the table on the right for pin definitions.

| Power Button<br>Pin Definitions (JF1) |             |
|---------------------------------------|-------------|
| Pin#                                  | Definition  |
| 1                                     | Signal      |
| 2                                     | +3V Standby |



**Note:** Do not close or short Pins 1 & 2 since this will cause the system to continuously reboot.

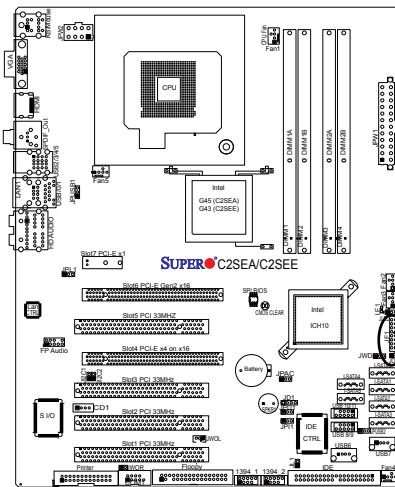

- A. Reset
- B. PWR Button

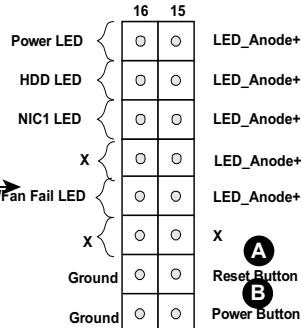

## 2-6 Connecting Cables

### ATX/Auxiliary Power Connectors

A 24-pin main power connector is located at JPW1, and a 8-pin power connector is located at JPW2 on the motherboard. These power connectors meet the SSI EPS 12V specification.

**Note:** The 8-pin 12V PWR supply is also required to provide adequate power to the processor. See the table on the right for pin definitions.



| ATX Power 24-pin Connector Pin Definitions |            |       |            |
|--|------------|-------|------------|
| Pin#                                       | Definition | Pin # | Definition |
| 13   | +3.3V      | 1     | +3.3V      |
| 14   | -12V       | 2     | +3.3V      |
| 15   | COM        | 3     | COM        |
| 16   | PS_ON      | 4     | +5V        |
| 17   | COM        | 5     | COM        |
| 18   | COM        | 6     | +5V        |
| 19   | COM        | 7     | COM        |
| 20   | Res (NC)   | 8     | PWR_OK     |
| 21   | +5V        | 9     | 5VSB       |
| 22   | +5V        | 10    | +12V       |
| 23   | +5V        | 11    | +12V       |
| 24   | COM        | 12    | +3.3V      |

| 12V 8-pin CPU PWR Pin Definitions |            |
|-----------------------------------|------------|
| Pins                              | Definition |
| 1 through 4                       | Ground     |
| 5 through 8                       | +12V       |

### Required Connection

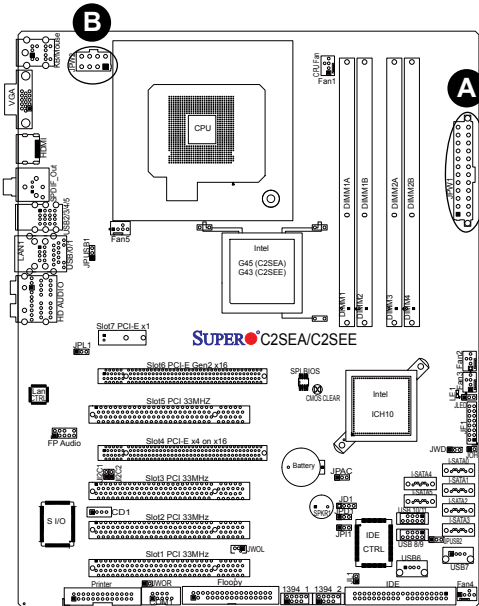

- A. 24-pin ATX PWR
- B. 8-pin PWR

## Universal Serial Bus (USB)

There are 12 USB 2.0 (Universal Serial Bus) ports/headers on the motherboard. Six of them are Back Panel USB ports: USB 0~1 (J4) and USB 2~5 (J7). USB 6, USB 7, USB 8~9 and USB 10~11 Front Panel USB headers that can be accessed from the front side of the chassis. See the tables on the right for pin definitions.

| Back Panel USB (0~5) |             |
|----------------------|-------------|
| Pin#                 | Definitions |
| 1                    | +5V         |
| 2                    | PO-         |
| 3                    | PO+         |
| 4                    | Ground      |
| 5                    | N/A         |

| Front Accessible Panel USB (6, 7, 8-9, 10-11) Connectors |            |              |               |
|--|------------|--------------|---------------|
| USB 8/10   |            | USB 6/7/9/11 |               |
| Pin #  | Definition | Pin #        | Definition    |
| 1  | +5V        | 1            | +5V           |
| 2  | PO-        | 2            | PO-           |
| 3  | PO+        | 3            | PO+           |
| 4  | Ground     | 4            | Ground        |
| 5  | Key        | 5            | No connection |

## GLAN 1 (Giga-bit Ethernet Port)

A Giga-bit Ethernet port is located above USB Ports 0~1 on the IO back-plane. This GLAN port accepts RJ45 type cables.

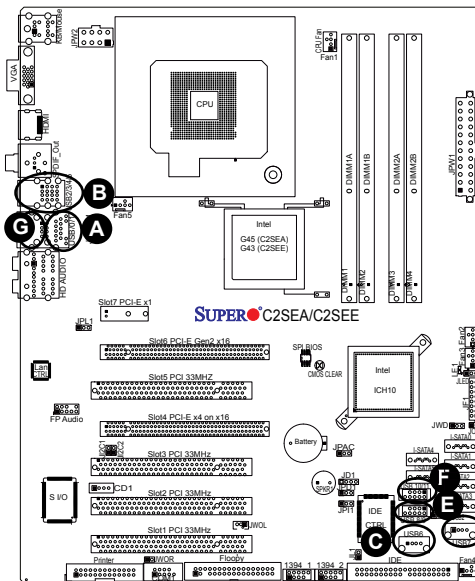

- A. Back panel USB Ports 0~1
- B. Back panel USB Ports 2~5
- C. FP USB 6
- D. FP USB 7
- E. FP USB 8~9
- F. FP USB 10~11
- G. GLAN1

**Overheat LED/Fan Fail (JOH)**

The JOH header is used to connect an LED to provide warning of chassis overheating. This LED will blink to indicate a fan failure. Refer to the table on right for pin definitions.

| Overheat LED Pin Definitions |            |
|------------------------------|------------|
| Pin#                         | Definition |
| 1                            | 3.3Vcc     |
| 2                            | OH Active  |

| OH/Fan Fail LED Status |          |
|------------------------|----------|
| State                  | Message  |
| Solid                  | Overheat |
| Blinking               | Fan Fail |

**Chassis Intrusion**

A Chassis Intrusion header is located at JL1 on the motherboard. Attach an appropriate cable from the chassis to inform you of a chassis intrusion when it is opened.

| Chassis Intrusion Pin Definitions (JL1) |                 |
|---|-----------------|
| Pin#                                    | Definition      |
| 1                                       | Intrusion Input |
| 2                                       | Ground          |

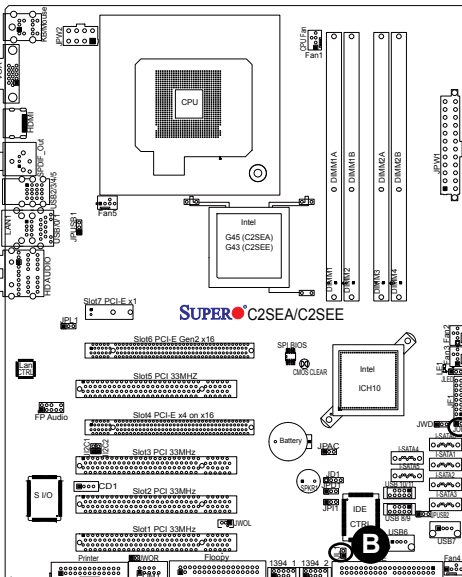

- A. Overheat LED
- B. Chassis Intrusion

## Fan Headers

The C2SEA/C2SEE has five chassis fan headers (Fan 1 to Fan 5). Fan 1 is the CPU Fan. Fan 2 to Fan 5 are system/chassis fans.



**Note:** Pins 1-3 of a 4-pin fan headers are backward compatible with the traditional 3-pin fans. See the table on the right for pin definitions. The onboard fan speeds are controlled by Thermal Management via BIOS Hardware Monitoring in the Advanced Setting. **(Note: Default: Disabled.** When using Thermal Management settings, please use all 3-pin fans or all 4-pin fans on the motherboard.)

| Fan Header<br>Pin Definitions (Fan1-3) |                |
|--|----------------|
| Pin#                                   | Definition     |
| 1                                      | Ground         |
| 2                                      | +12V           |
| 3                                      | Tachometer     |
| 4                                      | PWR Modulation |

## VGA Connector

A VGA connector is located next to the USB ports 2~5 on the IO backplane. Refer to the board layout below for the location.

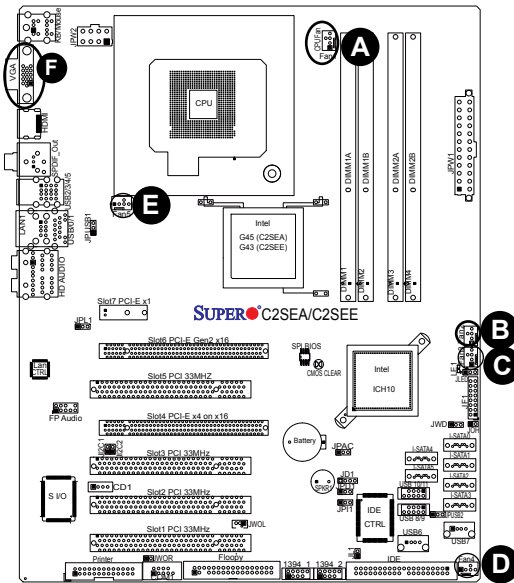

- A. Fan 1 (CPU Fan)
- B. Fan 2
- C. Fan 3
- D. Fan 4
- E. Fan 5
- F. VGA

**ATX PS/2 Keyboard and PS/2 Mouse Ports**

The ATX PS/2 keyboard and the PS/2 mouse are located on the backplane. See the table on the right for pin definitions. (The mouse port is above the keyboard port. See the table on the right for pin definitions.)

| PS/2 Keyboard and Mouse Port Pin Definitions |            |
|--|------------|
| Pin#   | Definition |
| 1  | Data       |
| 2  | NC         |
| 3  | Ground     |
| 4  | VCC        |
| 5  | Clock      |
| 6  | NC         |

**Serial Ports**

COM1 is located between the floppy drive connector and the printer port. See the table on the right for pin definitions.

| Serial Port Pin Definitions Pin Definitions |            |       |            |
|---|------------|-------|------------|
| Pin #                                       | Definition | Pin # | Definition |
| 1   | DCD        | 6     | DSR        |
| 2   | RXD        | 7     | RTS        |
| 3   | TXD        | 8     | CTS        |
| 4   | DTR        | 9     | RI         |
| 5   | Ground     | 10    | NC         |

(NC: No Connection.)

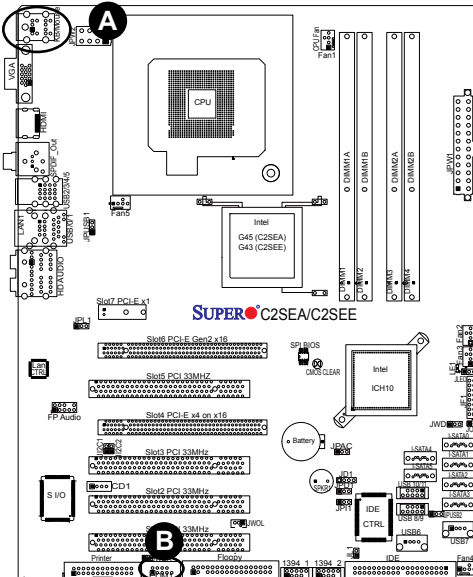

- A. Keyboard/Mouse
- B. COM1

### Wake-On-Ring

The Wake-On-Ring header is designated JWOR. This function allows your computer to wake-up when receiving an incoming call while in the suspend state. See the table on the right for pin definitions. You must have a Wake-On-Ring card and cable to use this feature.

| Wake-On-Ring Pin Definitions (JWOR) |            |
|-------------------------------------|------------|
| Pin#                                | Definition |
| 1                                   | Ground     |
| 2                                   | Wake-up    |

### Wake-On-LAN

The Wake-On-LAN header is located at JWOL on the motherboard. See the table on the right for pin definitions. (You must also have a LAN card with a Wake-On-LAN connector and cable to use this feature.)

| Wake-On-LAN Pin Definitions (JWOL) |             |
|------------------------------------|-------------|
| Pin#                               | Definition  |
| 1                                  | +5V Standby |
| 2                                  | Ground      |
| 3                                  | Wake-up     |

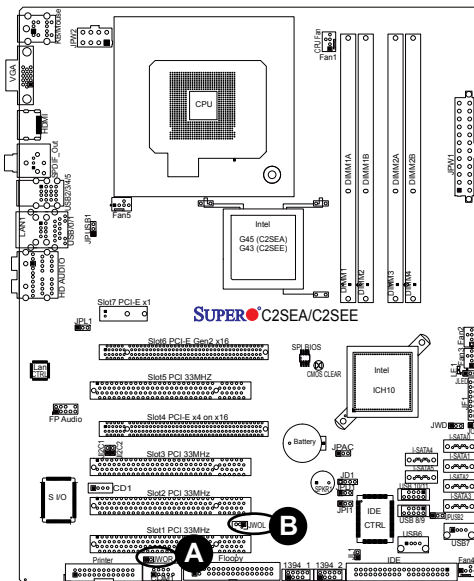

A. JWOR

B. JWOL

### High-Definition Audio (HDA)

The C2SEA/C2SEE features a 7.1+2 Channel High-Definition Audio (HDA) (J8) codec that provides 10 DAC channels, simultaneously supporting 7.1 sound playback and two channels of independent stereo sound output (multiple streaming) through the front panel stereo out for the front L&R, rear L&R, center and subwoofer speakers. This feature is activated with an advanced software included in the CD-ROM that came with your motherboard. Sound is then output through the Line In, Line Out and MIC jacks. (See at the picture at right.)

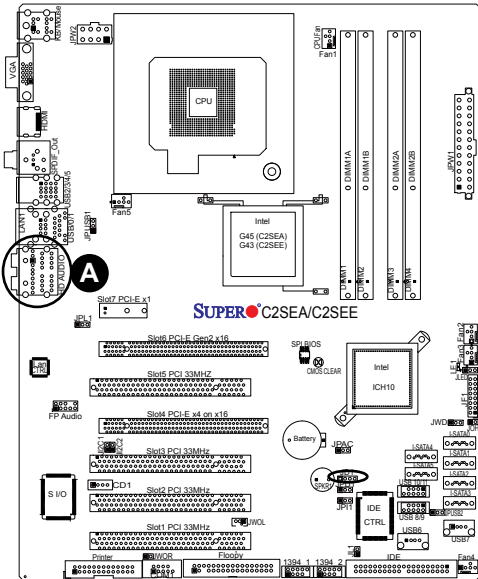
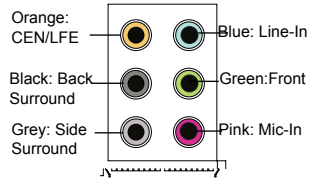

A. High-Definition Audio



## Front Panel Audio Control

When front panel headphones are plugged in, the back panel audio output is disabled. This is done through the FP Audio header (J12). If the front panel interface card is not connected to the front panel audio header, jumpers should be installed on the header (J12) pin pairs: 1-2, 5-6, and 9-10. If these jumpers are not installed, the back panel line out connector will be disabled and microphone input Pin 1 will be left floating, which can lead to excessive back panel microphone noise and cross talk. See the table below for pin definitions.

| FP Audio Pin Definitions |                 |
|--------------------------|-----------------|
| Pin#                     | Defin.          |
| 1                        | MIC_L           |
| 2                        | AUD_GND         |
| 3                        | MIC_R           |
| 4                        | FP-Audio-Detect |
| 5                        | Line_2_R        |
| 6                        | Ground          |
| 7                        | FP-Jack-Detect  |
| 8                        | Key             |
| 9                        | Line_2_L        |
| 10                       | Ground          |

## CD Header

In addition to the front panel audio connector, a 4-pin CD header is located at CD1 on the motherboard. These headers allow you to use the onboard sound for audio CD playback. Connect an audio cable from your CD drive to the header that fits your cable's connector. Only one CD header can be used at any one time. See the tables at right for pin definitions.

| CD1 Pin Definition |                     |
|--------------------|---------------------|
| Pin#               | Definition          |
| 1                  | Left Stereo Signal  |
| 2                  | Ground              |
| 3                  | Ground              |
| 4                  | Right Stereo Signal |

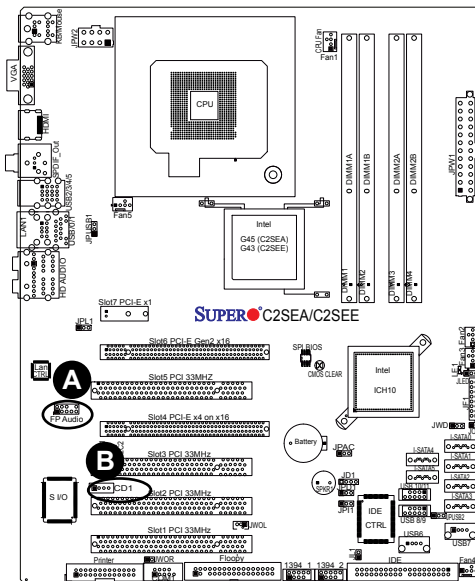

A. Front Panel Audio

B. CD-In

**S/PDIF\_Out Connector**

An S/PDIF\_Out connector is located next to the Backpanel USB ports on the motherboard. The S/PDIF(Sony/Philips Digital Interface Format) connector is used for transporting stereo digital audio signals. It is commonly used to connect the output of a DVD player to a home theater receiver that supports Dolby Digital or DTS surround sound. The S/PDIF\_Out connector includes the top component (S/PDIF\_RCA) and the bottom component (S/PDIF). See the tables below for pin definitions.

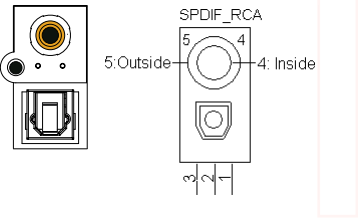

| S/PDIF_RCA (Top Component) Pin Definition |               |
|---|---------------|
| Pin Location                              | Definition    |
| Outside                                   | Ground        |
| Inside                                    | S/PDIF Signal |

| S/PDIF (Bottom Component) Pin Definition |               |
|--|---------------|
| Pin#                                     | Definition    |
| 1  | Ground        |
| 2  | Vcc           |
| 3  | S/PDIF Signal |

**HDMI Connector (C2SEA only)**

A High-Definition Multimedia Interface (HDMI) connector is located on the IO Backplane on the motherboard. This connector provides HD audio/video interface support to the onboard audio and video connections. See the table below for pin definitions.

| HDMI Pin Definitions |                 |      |                |
|----------------------|-----------------|------|----------------|
| Pin#                 | Defin.          | Pin# | Defin.         |
| 1                    | TMDS Data2+     | 2    | GND            |
| 3                    | TMDS Data2-     | 4    | TMDS Data1+    |
| 5                    | GND             | 6    | TMDS Data1-    |
| 7                    | TMDS Data0+     | 8    | GND            |
| 9                    | TMDS Data0-     | 10   | TMDS Clock+    |
| 11                   | GND             | 12   | TMDS Clock-    |
| 13                   | NA              | 14   | Reversed (NC)  |
| 15                   | SCL             | 16   | SDA            |
| 17                   | DDC/ICED GND    | 18   | +5V PWR <=50mA |
| 19                   | Hot Plug Detect |      | NA             |

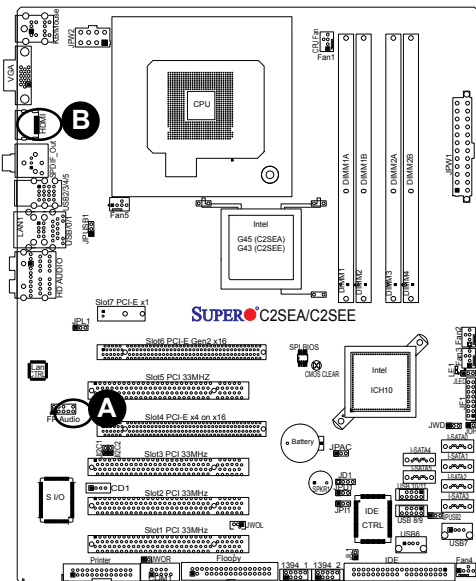

- A. S/PDIF
- B. HDMI Connector

### 1394\_1/1394\_2 Connections (C2SEA only)

1394\_1 and 1394\_2 provide the IEEE 1394a connections on the motherboard. See the tables on the right for pin definitions.

| 1394_1 Pin Definitions |          |      |          |
|------------------------|----------|------|----------|
| Pin#                   | Defin.   | Pin# | Defin    |
| 1                      | PTPA0+   | 2    | PTPA0-   |
| 3                      | GND      | 4    | GND      |
| 5                      | PTPB0+   | 6    | PTPB0-   |
| 7                      | PWR 1394 | 8    | PWR 1394 |
| 9                      | NC       | 10   | ZX       |

| J1394_2 Pin Definitions |          |      |          |
|-------------------------|----------|------|----------|
| Pin#                    | Defin.   | Pin# | Defin    |
| 1                       | PTPA1+   | 2    | PTPA1-   |
| 3                       | GND      | 4    | GND      |
| 5                       | PTPB1+   | 6    | PTPB1-   |
| 7                       | PWR 1394 | 8    | PWR 1394 |
| 9                       | NC       | 10   | ZY       |

(NC=No connection)

| PWR LED Pin Definitions |            |
|-------------------------|------------|
| Pin#                    | Definition |
| 1                       | 3.3V       |
| 2                       | Key        |
| 3                       | Ground     |

### Power LED

The Power LED connector is designated JLED. This connection is used to provide LED Indication of power supplied to the system. See the table on the right for pin definitions.

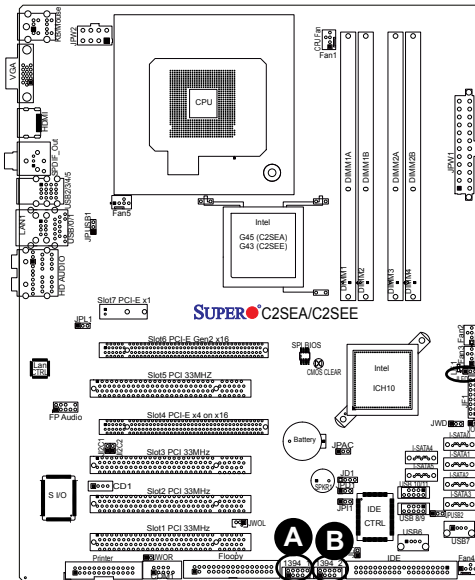

- A. 1394\_1
- B. 1394\_2
- C. PWR LED

## 2-7 Jumper Settings

### Explanation of Jumpers

To modify the operation of the motherboard, jumpers can be used to choose between optional settings. Jumpers create shorts between two pins to change the function of the connector. Pin 1 is identified with a square solder pad on the printed circuit board. See the motherboard layout pages for jumper locations.

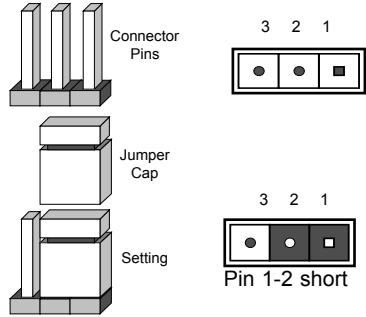

**Note:** On two pin jumpers, "Closed" means the jumper is on and "Open" means the jumper is off the pins.

### GLAN Enable/Disable

JPL1 enables or disables GLAN1 Port on the motherboard. See the table on the right for jumper settings. The default setting is enabled.

| GLAN Enable JPL1 |                   |
|------------------|-------------------|
| Pin#             | Definition        |
| 1-2              | Enabled (default) |
| 2-3              | Disabled          |

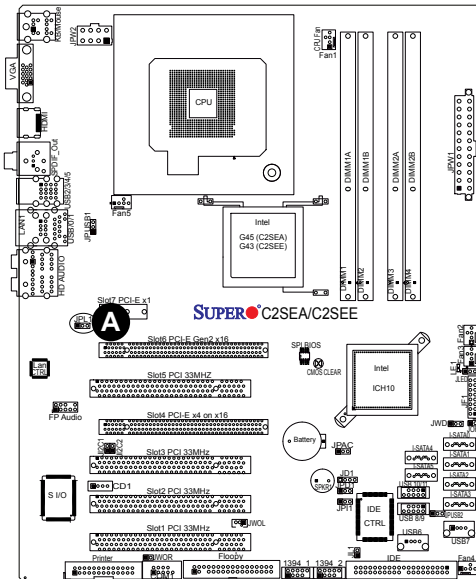

### A. GLAN Port 1 Enable

## Watch Dog Enable/Disable

Watch Dog is a system monitor that can re-boot the system when a software application hangs. Close pins 1-2 to reset the system if an application hangs. Close pins 2-3 to generate a non-maskable interrupt signal for the application that hangs. See the table on the right for jumper settings. Watch Dog must also be enabled in the BIOS. (**Note:** When enabled, the user needs to write his/her own application software to disable the WD Timer.)

| Watch Dog Jumper Settings (JWD) |                 |
|---------------------------------|-----------------|
| Jumper Setting                  | Definition      |
| Pins 1-2                        | Reset (default) |
| Pins 2-3                        | NMI             |
| Open                            | Disabled        |

## IEEE 1394a Enable

JPI1 allows the user to use the onboard IEEE 1394\_1 and 1394\_2 connections. Close Pins 1 and 2 of this jumper to use this feature. See the table on the right for jumper settings. The default setting is Enabled.

| 1394a Enable Jumper Settings |                   |
|------------------------------|-------------------|
| Pin#                         | Definition        |
| 1-2                          | Enabled (default) |
| 2-3                          | Disabled          |

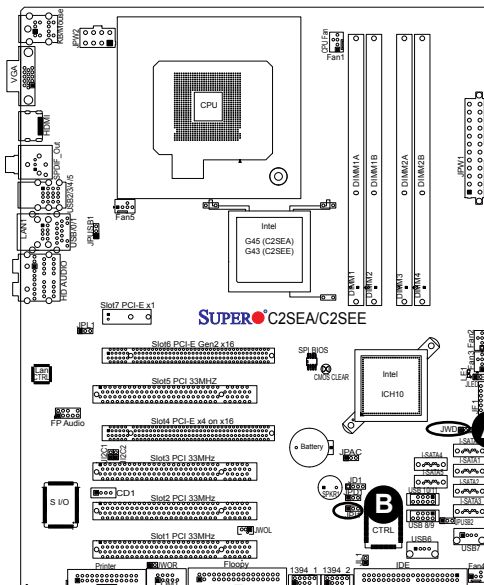

- A. Watch Dog Enable
- B. 1394\_1/1394\_2 Enable

**PCI/PCI-E Slots to SMB Speeds**

Jumpers J1<sup>2</sup>C1/J1<sup>2</sup>C2 allow you to connect PCI/PCI-Exp. Slots to the System Management Bus. The default setting is open to disable the connection. See the table on the right for jumper settings.

| SMBus to PCI-X/PCI-Exp Slots Jumper Settings |                    |
|--|--------------------|
| Jumper Setting                               | Definition         |
| Closed                                       | Enabled            |
| Open   | Disabled (Default) |

**Clear CMOS**

JBT1 is used to clear CMOS. Instead of pins, this "jumper" consists of contact pads to prevent the accidental clearing of CMOS. To clear CMOS, use a metal object such as a small screwdriver to touch both pads at the same time to short the connection. Always remove the AC power cord from the system before clearing CMOS. ⌚



**Note:** For an ATX power supply, you must completely shut down the system, remove the AC power cord and then close pins 1 and 2 to clear CMOS.

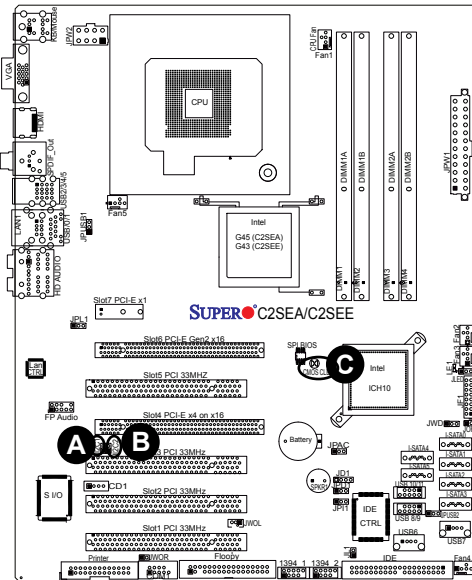

- A. J1<sup>2</sup>C1
- B. J1<sup>2</sup>C2
- C. JBT1

### IDE Enable/Disable (C2SEA Only)

JPD1 enables or disables IDE on the C2SEA. See the table on the right for jumper settings. The default setting is **Enabled**.

| IDE Enable (JPD1) |                   |
|-------------------|-------------------|
| Pin#              | Definition        |
| 1-2               | Enabled (default) |
| 2-3               | Disabled          |

### Audio Enable

JPAC enables or disables the onboard audio connections. See the table on the right for jumper settings. The default setting is Enabled.

| Audio Enable (JPAC) |                   |
|---------------------|-------------------|
| Pin#                | Definition        |
| 1-2                 | Enabled (default) |
| 2-3                 | Disabled          |

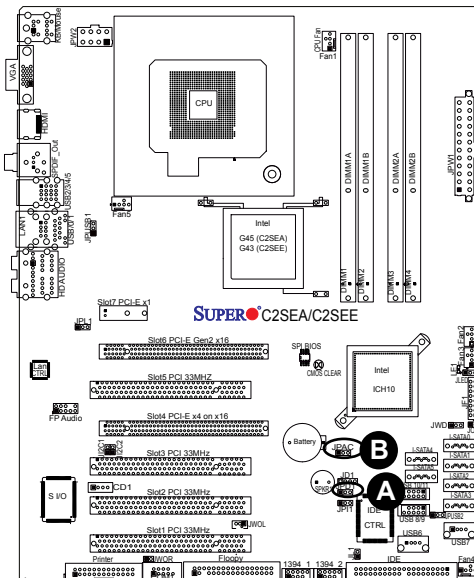

- A. IDE Enable
- B. Audio Enable

**USB Wake-Up**

Use JPUSB jumpers to "wake-up" your system by pressing a key on a USB keyboard or by clicking the USB mouse of your system. The JPUSB jumpers are used together with the USB Wake-Up feature in the BIOS. Enable both the jumpers and the BIOS setting to allow the system to "wake-up via USB devices". See the table on the right for jumper settings and jumper connections.



**Note:** JPUSB1 is for Back Panel USB ports #2~5, and JPUSB2 is for Front Panel USB ports #6, #7, #8~9 and #10~11.) The default jumper setting is set to **Disabled**. However, when the "USB Wake-Up" function is enabled in the BIOS, and the desired USB ports are enabled via the JPUSB jumper, please be sure to remove all USB devices from the USB ports whose USB jumpers are set to Disabled before the system goes into the standby mode.

| JPUSB1 (Back Panel USB Wake-up) |                    |
|---------------------------------|--------------------|
| Pin#                            | Definition         |
| 1-2                             | Disabled (Default) |
| 2-3                             | Enabled            |

| JPUSB2 (Front Panel USB Wake-up) |                    |
|----------------------------------|--------------------|
| Pin#                             | Definition         |
| 1-2                              | Disabled (Default) |
| 2-3                              | Enabled            |

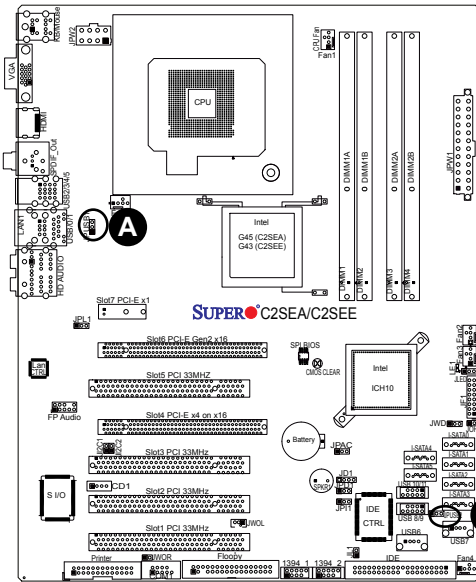

- A. JPUSB1
- B. JPUSB2



## Onboard Speaker Enable

An onboard speaker (Buzzer) enable jumper is located at JD1 on the motherboard. Close pins 3-4 to use the onboard speaker. Connect a cable to pins 1-4 to use an external speaker.

| Onboard Speaker Enable Jumper Settings |                  |
|--|------------------|
| Pin Setting                            | Definition       |
| Pins 3-4                               | Onboard Speaker  |
| Pins 1-4                               | External Speaker |

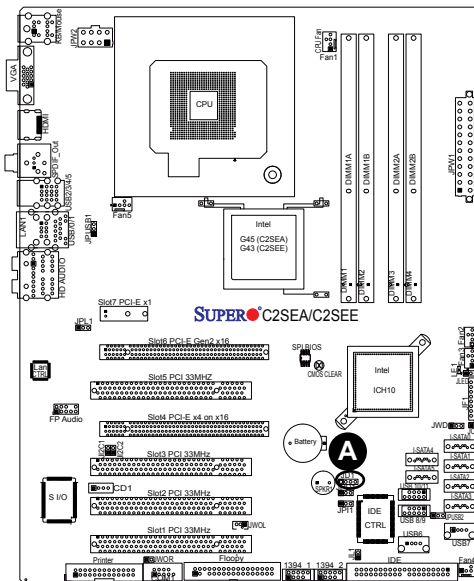

**A.** Onboard Speaker Enable

## 2-8 Onboard Indicators

### GLAN LEDs

There is one Gigabit-LAN port. This Gigabit Ethernet LAN port has two LEDs. The yellow GLAN Activity LED (right, see below) indicates activity, while the GLAN Link/Speed LED (left) may be green, amber or off to indicate the speed of the connection. See the tables at right for more information.

| GLAN Link/Speed LED Indicator |                          |
|-------------------------------|--------------------------|
| LED Color                     | Definition               |
| Off                           | No Connection or 10 Mbps |
| Green (On)                    | 100 Mbps                 |
| Amber (On)                    | 1 Gbps                   |

| GLAN Activity LED Indicator |                  |
|-----------------------------|------------------|
| Color                       | Definition       |
| Yellow (Flashing)           | ConnectionActive |

GLAN Link/Speed LED

GLAN Activity LED

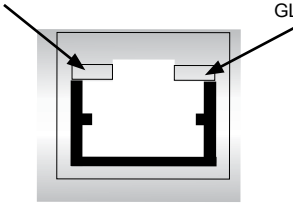

**Rear View**  
(When viewing from the rear side of the chassis.)

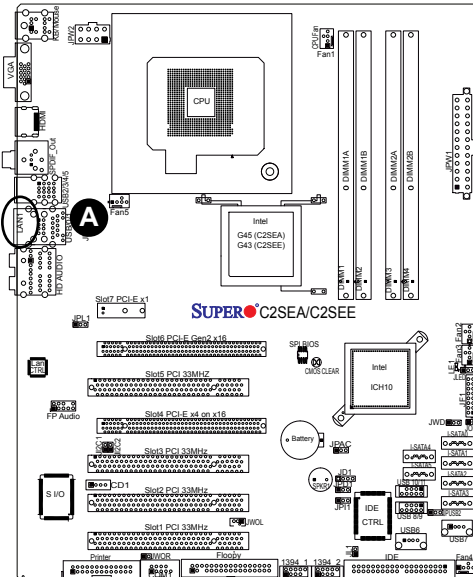

A. GLAN 1 LEDs

## Onboard Power LED (LE1)

The Onboard 3.3V Standby Power LED is located at LE1 on the motherboard. When LE1 is off, the system is off. When the LED is on, the power is on. Unplug the power cable before removing or installing components. See the layout below for the LED location.

| Onboard PWR LED Indicator (LE1) |                  |
|---------------------------------|------------------|
| LED Color                       | Definition       |
| Off                             | System Off       |
| On                              | Standby Power On |

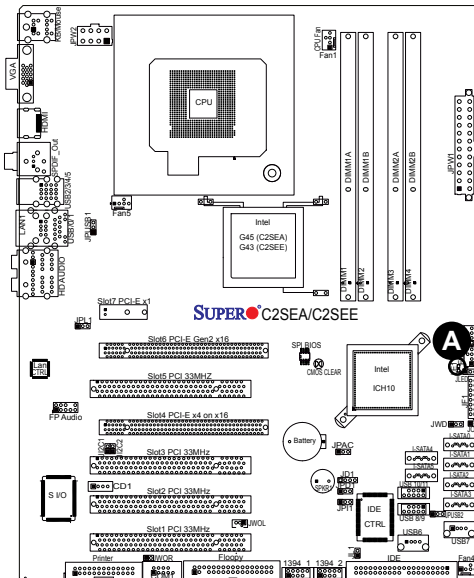

### A. Power LED

## 2-9 Parallel Port Connector and IDE Hard Drive Connections

Note the following when connecting the hard disk drive cables:

- A red mark on a wire typically designates the location of pin 1.

### Parallel Port Connector

The parallel (printer) connector is located at J13 on the motherboard. See the table on the right for pin definitions.

| Parallel (Printer) Connector<br>Pin Definitions |            |       |            |
|---|------------|-------|------------|
| Pin#  | Definition | Pin # | Definition |
| 1   | Strobe-    | 2     | Auto Feed- |
| 3   | Data Bit 0 | 4     | Error-     |
| 5   | Data Bit 1 | 6     | Init-      |
| 7   | Data Bit 2 | 8     | SLCT IN-   |
| 9   | Data Bit 3 | 10    | GND        |
| 11  | Data Bit 4 | 12    | GND        |
| 13  | Data Bit 5 | 14    | GND        |
| 15  | Data Bit 6 | 16    | GND        |
| 17  | Data Bit 7 | 18    | GND        |
| 19  | ACK        | 20    | GND        |
| 21  | BUSY       | 22    | GND        |
| 23  | PE         | 24    | GND        |
| 25  | SLCT       | 26    | NC         |

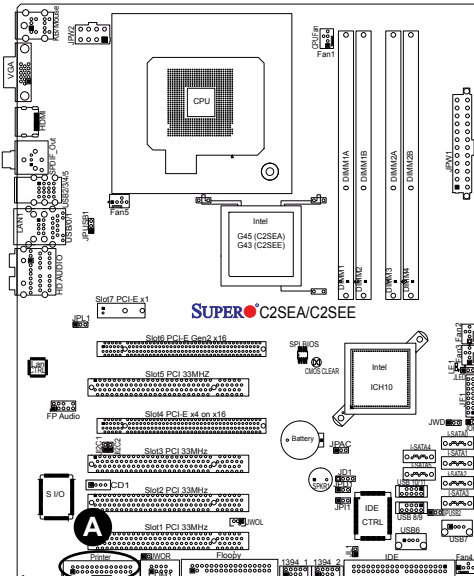

A. Printer

## IDE Connector (C2SEAOnly)

There is one IDE Connector on the C2SEA. This connection supports two IDE devices. Be sure to close Pin 1 and Pin 2 of JPD1 to enable the IDE connector before using it. See the table on the right for pin definitions.

| IDE Connector Pin Definitions |               |       |               |
|-------------------------------|---------------|-------|---------------|
| Pins#                         | Definition    | Pin # | Definition    |
| 1                             | Reset IDE     | 2     | Ground        |
| 3                             | Host Data 7   | 4     | Host Data 8   |
| 5                             | Host Data 6   | 6     | Host Data 9   |
| 7                             | Host Data 5   | 8     | Host Data 10  |
| 9                             | Host Data 4   | 10    | Host Data 11  |
| 11                            | Host Data 3   | 12    | Host Data 12  |
| 13                            | Host Data 2   | 14    | Host Data 13  |
| 15                            | Host Data 1   | 16    | Host Data 14  |
| 17                            | Host Data 0   | 18    | Host Data 15  |
| 19                            | Ground        | 20    | Key           |
| 21                            | DRQ3          | 22    | Ground        |
| 23                            | I/O Write     | 24    | Ground        |
| 25                            | I/O Read      | 26    | Ground        |
| 27                            | IOCHRDY       | 28    | BALE          |
| 29                            | DACK3         | 30    | Ground        |
| 31                            | IRQ14         | 32    | IOCS16        |
| 33                            | Addr1         | 34    | Ground        |
| 35                            | Addr0         | 36    | Addr2         |
| 37                            | Chip Select 0 | 38    | Chip Select 1 |
| 39                            | Activity      | 40    | Ground        |

### A. IDE Connector

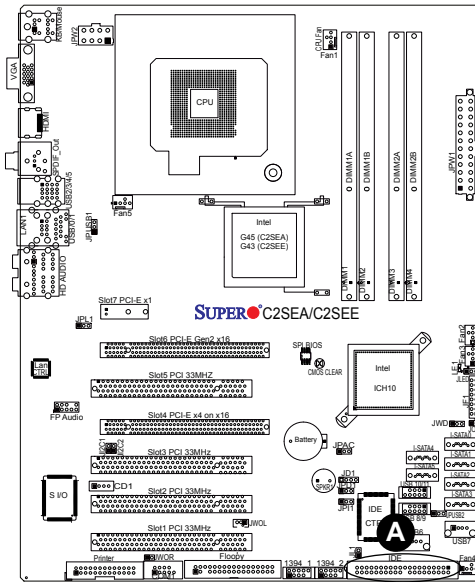

## Notes

## Chapter 3

# Troubleshooting

### 3-1 Troubleshooting Procedures

Use the following procedures to troubleshoot your system. If you have followed all of the procedures below and still need assistance, refer to the 'Technical Support Procedures' and/or 'Returning Merchandise for Service' section(s) in this chapter. Always disconnect the AC power cord before adding, changing or installing any hardware components.

#### **Before Power On**

1. Make sure that there are no short circuits between the motherboard and chassis.
2. Disconnect all ribbon/wire cables from the motherboard, including those for the keyboard and mouse.
3. Remove all add-on cards.
4. Install a CPU and heatsink (making sure it is fully seated) and connect the chassis speaker and the power LED to the motherboard. Check all jumper settings as well.
5. Use the correct type of onboard CMOS battery as specified by the Manufacturer. Do not install the CMOS battery upside down to avoid possible explosion.
6. Make sure the 8-pin 12v power connector at JPWR2 is connected to your power supply.

#### **No Power**

1. Make sure that there are no short circuits between the motherboard and chassis.
2. Verify that all jumpers are set to their default positions.
3. Check that the 115V/230V switch on the power supply is properly set.

4. Turn the power switch on and off to test the system.
5. The battery on your motherboard may be old. Check to verify that it still supplies ~3VDC. If it does not, replace it with a new one.

### No Video

1. If the power is on but you have no video, remove all the add-on cards and cables.
2. Use the speaker to determine if any beep codes exist. Refer to Appendix A for details on beep codes.



**Note:** If you are a system integrator, VAR or OEM, a POST diagnostics card is recommended.

### Memory Errors

1. Make sure that the DIMM modules are properly and fully installed.
2. You should be using unbuffered DDR3 memory (see the next page). Also, it is recommended that you use the same memory speed for all DIMMs in the system. See Section 2-4 for memory limitations.
3. Check for bad DIMM modules or slots by swapping modules between slots and noting the results.
4. Check the power supply voltage 115V/230V switch.

### Losing the System's Setup Configuration

1. Make sure that you are using a high quality power supply. A poor quality power supply may cause the system to lose the CMOS setup information. Refer to Section 1-6 for details on recommended power supplies.
2. The battery on your motherboard may be old. Check to verify that it still supplies ~3VDC. If it does not, replace it with a new one.
3. If the above steps do not fix the Setup Configuration problem, contact your vendor for repairs.



## 3-2 Technical Support Procedures

Before contacting Technical Support, please take the following steps. Also, note that as a motherboard manufacturer, Supermicro does not sell directly to end-users, so it is best to first check with your distributor or reseller for troubleshooting services. They should know of any possible problem(s) with the specific system configuration that was sold to you.

1. Please go through the 'Troubleshooting Procedures' and 'Frequently Asked Question' (FAQ) sections in this chapter or see the FAQs on our web site (<http://www.supermicro.com/support/faqs/>) before contacting Technical Support.
2. BIOS upgrades can be downloaded from our web site at (<http://www.supermicro.com/support/bios/>).



**Note:** Not all BIOS can be flashed; some cannot be flashed. It depends on the modifications to the boot block code.

3. If you still cannot resolve the problem, include the following information when contacting Supermicro for technical support:
  - Motherboard model and PCB revision number
  - BIOS release date/version (this can be seen on the initial display when your system first boots up)
  - System configuration
  - An example of a Technical Support form is on our web site at (<http://www.supermicro.com/support/contact.cfm>).
4. Distributors: For immediate assistance, please have your account number ready when placing a call to our technical support department. We can be reached by e-mail at [support@supermicro.com](mailto:support@supermicro.com), by phone at:(408) 503-8000, option 2, or by fax at (408)503-8019.

### 3-3 Frequently Asked Questions

**Question:** What type of memory does my motherboard support?

**Answer:** The C2SEA/C2SEE supports **unbuffered**, DDR3 1333/1066/800 MHz memory modules. See Section 2-4 for details on installing memory.

**Question:** Why does Microsoft Windows XP (SP2) and Windows Vista show less memory than what is physically installed?

**Answer:** Microsoft implemented a design change in Windows XP with Service Pack 2 (SP2) and Windows Vista. This change is specific to the Physical Address Extension (PAE) mode behavior which improves driver compatibility. For more information, please read the following article at Microsoft's Knowledge Base website at: <http://support.microsoft.com/kb/888137>.

**Question:** How do I update my AMI BIOS?

**Answer:** It is recommended that you **do not** upgrade your BIOS if you are not experiencing any problems with your system. Updated BIOS files are located on our web site at <http://www.supermicro.com/support/bios/>. Please check our BIOS warning message and the information on how to update your BIOS on our web site. Select your motherboard model and download the BIOS (.rom) file to your computer. Also, check the current BIOS revision and make sure that it is newer than your BIOS before downloading. You may choose the zip file or the .exe file. If you choose the zipped BIOS file, please unzip the BIOS file onto a bootable device or a USB pen/thumb drive. To flash the BIOS, run the batch file named "ami.bat" with the new BIOS .rom file from your bootable device or USB pen/thumb drive. Use the following format:

```
F:\> ami xxxxxxxx.rom <Enter>
```



**Notes:** Be sure to type in a space after "ami". Always use the file named "ami.bat" to update the BIOS.

When completed, your system will automatically reboot. If you choose the .exe file, please run the .exe file under Windows to create the BIOS flash floppy disk. Insert the floppy disk into the system you wish to flash the BIOS. Then, boot the system to the floppy disk. The BIOS utility will automatically flash the BIOS without any prompts. Please note that this process may take a few minutes to complete. Do not be concerned if the screen is paused for a few minutes.



**Warning:** Do not shut down or reset the system while updating the BIOS to prevent possible system boot failure!

When the BIOS flashing screen is completed, the system will reboot and will show "Press F1 or F2". At this point, you will need to load the BIOS defaults. Press <F1> to go to the BIOS setup screen, and press <F9> to load the default settings. Next, press <F10> to save and exit. The system will then reboot.



**Note:** The SPI BIOS chip installed on this motherboard is not removable. To repair or replace a damaged BIOS chip, please send your motherboard to RMA at Supermicro for service.

**Question:** I think my BIOS is corrupted. How can I recover my BIOS?

**Answer:** Please see Appendix D, BIOS Recovery for detailed instructions.

**Question:** What's on the CD that came with my motherboard?

**Answer:** The supplied compact disc has quite a few drivers and programs that will greatly enhance your system. We recommend that you review the CD and install the applications you need. Applications on the CD include chipset drivers for Windows and security and audio drivers.

**Question:** How do I utilize the onboard HD sound?

**Answer:** The onboard HD sound available on the C2SEA/C2SEE can be enabled with the audio driver software that was included in your motherboard package. When activated, sound will be routed through the jacks next to the LAN Port according to the audio connection descriptions listed on Page 2-8. You must also set the HD Audio setting to "Auto" in the Advanced Chipset section of the BIOS setup.

**Question:** I installed my microphone correctly, but I can't record any sound. What should I do?

**Answer:** Go to <Start>, <Programs>, <Accessories>, <Entertainment> and then <Volume Control>. Under the Properties tab, scroll down the list of devices in the menu and check the box beside "Microphone".

**Question:** After I have installed 4 pieces of 1GB Memory, why does the BIOS only detect about 3.145 GB of memory during POST?

**Answer:** Because the chipset does not support memory remapping, and PCI-E memory requires a great deal of memory, so there is a memory hole located around the 4GB memory address.

**Question:** How do I connect the ATA100/66 cable to my IDE device(s)?

**Answer:** The 80-wire/40-pin high-density ATA100/66 IDE cable that came with your system has two connectors to support two drives. This special cable must be used to take advantage of the speed the ATA100/66 technology offers.

**Connect the blue connector to the onboard IDE header and the other connector(s) to your hard drive(s).** Consult the documentation that came with your disk drive for details on actual jumper locations and settings.

### **3-4 Returning Merchandise for Service**

A receipt or copy of your invoice marked with the date of purchase is required before any warranty service will be rendered. You can obtain service by calling your vendor for a Returned Merchandise Authorization (RMA) number. When returning to the manufacturer, the RMA number should be prominently displayed on the outside of the shipping carton, and mailed prepaid or hand-carried. Shipping and handling charges will be applied for all orders that must be mailed when service is complete.

For faster service, RMA authorizations may be requested online (<http://www.super-micro.com/support/rma/>).

This warranty only covers normal consumer use and does not cover damages incurred in shipping or from failure due to the alteration, misuse, abuse or improper maintenance of products.

During the warranty period, contact your distributor first for any product problems.

## Chapter 4

# BIOS

### 4-1 Introduction

This chapter describes the AMI BIOS Setup Utility for the C2SEA/C2SEE. The AMI ROM BIOS is stored in a Flash EEPROM and can be easily updated. This chapter describes the basic navigation of the AMI BIOS Setup Utility setup screens.

#### Starting BIOS Setup Utility

To enter the AMI BIOS Setup Utility screens, press the <Delete> key while the system is booting up.

**Note:** In most cases, the <Delete> key is used to invoke the AMI BIOS setup screen. There are a few cases when other keys are used, such as <F1>, <F2>, etc.

Each main BIOS menu option is described in this manual. The Main BIOS setup menu screen has two main frames. The left frame displays all the options that can be configured. Grayed-out options cannot be configured. Options in blue can be configured by the user. The right frame displays the key legend. Above the key legend is an area reserved for a text message. When an option is selected in the left frame, it is highlighted in white. Often a text message will accompany it. (**Note:** the AMI BIOS has default text messages built in. Supermicro retains the option to include, omit, or change any of these text messages.)

The AMI BIOS Setup Utility uses a key-based navigation system called hot keys. Most of the AMI BIOS setup utility hot keys can be used at any time during the setup navigation process. These keys include <F1>, <F10>, <Enter>, <ESC>, arrow keys, etc. (**Note:** Options printed in **Bold** are default settings.)

#### How To Change the Configuration Data

The configuration data that determines the system parameters may be changed by entering the AMI BIOS Setup utility. This Setup utility can be accessed by pressing <Del> at the appropriate time during system boot.

#### Starting the Setup Utility

Normally, the only visible POST (Power On Self Test) routine is the memory test. As the memory is being tested, press the <Delete> key to enter the main menu of the AMI BIOS Setup Utility. From the main menu, you can access the other setup

screens. An AMI BIOS identification string is displayed at the left bottom corner of the screen, below the copyright message.



**Warning!!** Do not shut down or reset the system while updating BIOS to prevent possible boot failure.

## 4-2 Main Setup

When you first enter the AMI BIOS Setup Utility, you will enter the Main setup screen. You can always return to the Main setup screen by selecting the Main tab on the top of the screen. The Main BIOS Setup screen is shown below.



**System Overview:** The following BIOS information will be displayed:

### System Time/System Date

Use this option to change the system time and date. Highlight *System Time* or *System Date* using the arrow keys. Enter new values through the keyboard. Press the <Tab> key or the arrow keys to move between fields. The date must be entered in DAY/MM/DD/YY format. The time is entered in HH:MM:SS format. (**Note:** The time is in 24-hour format. For example, 5:30 A.M. appears as 05:30:00.)

AMIBIOS

Version

Build Date

ID

### **Processor**

When you select this option, the AMI BIOS will automatically display the status of processors as shown below:

Speed

Count

### **System Memory**

This option allows the AMI BIOS to display the status of memory modules installed in the system.

## 4-3 Advanced Setup Configurations

Use the arrow keys to select Boot Setup and hit <Enter> to access the submenu items:

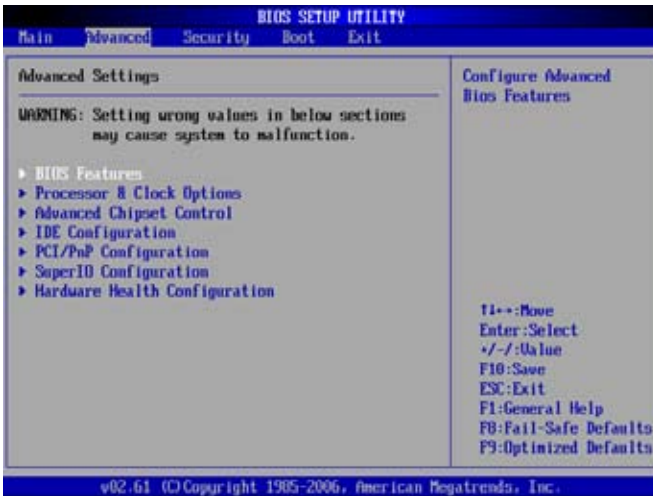

### ► BIOS Features

#### QuickBoot

If Enabled, this option will skip certain tests during POST to reduce the time needed for system boot. The options are **Enabled** and Disabled.

#### QuietBoot

This option allows the bootup screen options to be modified between POST messages or the OEM logo. Select Disabled to allow the computer system to display the POST messages. Select **Enabled** to allow the computer system to display the OEM logo.

#### Wait for 'F1' If Error

Select Enable to allow the system to wait for the user to press F1 when an error occurs. The options are **Enabled** and Disabled.

#### High Performance Event Timer

Select Enabled to activate the High Performance Event Timer (HPET) that produce periodic interrupts at a much higher frequency than a Real-time Clock (RTC) can in synchronizing multimedia streams, providing smooth playback and reducing the dependency on other timestamp calculation devices, such as an x86 RDTSC Instruction embedded in a CPU. The High Performance Event Timer is used to replace the 8254 Programmable Interval Timer. The options are Enabled and **Disabled**.



## ► ACPI Configuration

Use this feature to configure ACPI (Advanced Configuration and Power Interface) power management settings for your system.

### ACPI Aware OS

Select **Yes** to enable ACPI support for the OS. Disable this feature if ACPI is not supported by your OS. The options are **Yes** and **No**.

### Suspend Mode

This setting allows you to configure the ACPI (Advanced Configuration and Power Interface) state for your system when it is in the Suspend mode. The options are **S1 (POS)**, **S3 (STR)** and **Auto**.

### ACPI Version Feature

This feature allows the user to select ACPI Version for the system. The options are ACPI v1.0, **ACPI v2.0**, and ACPI v3.0.

### Watch Dog Function

Select **Enabled** to enable Watch Dog Timer and allow the system to reboot when it is inactive for more than 5 minutes. The options are **Enabled** and **Disabled**.

### USB Device Wake Up

Select **Enabled** to "wake-up" the system via a USB device when the system is in S3 (Standby) or S4 (Hibernate) State. The options are **Enabled** and **Disabled**.

### PS2 KB/MS Wake Up

Select **Enabled** to "wake-up" the system using either the PS2 keyboard or mouse (if equipped) when the system is in S3 (Sleep) or S4 (Hibernate) state. The options are **Enabled** and **Disabled**.

### Restore on AC Power Loss

The feature allows the user to set the power state after a power outage. Select **Power-Off** for the system power to remain off after a power loss. Select **Power-On** for the system power to be turned on after a power loss. Select **Last State** to allow the system to resume its last state before a power loss. The options are **Power-On**, **Power-Off** and **Last State**.

### MPS Revision

This feature allows the user to specify the version of the Multi-Processor Specification (MPS) the motherboard is using. The options are **1.4** and **1.1**.

### Interrupt 19 Capture

Interrupt 19 is the software interrupt that handles the boot disk function. When this item is set to Enabled, the ROM BIOS of the host adaptors will "capture" Interrupt 19 at boot and allow the drives that are attached to these host adaptors to function as bootable disks. If this item is set to **Disabled**, the ROM BIOS of the host adaptors will not capture Interrupt 19, and the drives attached to these adaptors will not function as bootable devices.

## ►Processor & Clock Options

### Warning



When you first enter the Advanced Setup screen, the Setup Warning will be displayed. Follow the instructions and set the correct value for each item to ensure that the system functions properly.

### Ratio CMOS Setting

This option allows the user to set the ratio between the CPU Core Clock and the FSB Frequency. (**Note:** if an invalid ratio is entered, the AMI BIOS will restore the setting to the previous state.)

#### CPU VID

This feature allows the user to set VID for the processor. When this feature is set to Enabled, C1E and TM2 might not function properly. The default setting is **Default**.

### Hardware Prefetcher (Available when supported by the OS and the CPU)

If set to Enabled, the hardware prefetcher will prefetch streams of data and instructions from the main memory to the L2 cache in the forward or backward manner to improve CPU performance. The options are Disabled and **Enabled**.

### Adjacent Cache Line Prefetch (Available when supported by the OS and the CPU)

The CPU fetches the cache line for 64 bytes if this option is set to Disabled. The CPU fetches both cache lines for 128 bytes as comprised if **Enabled**.

### Max CPUID Value Limit

This feature allows the user to set the maximum CPU ID value. Enable this function to boot the legacy operating systems that cannot support processors with extended CPUID functions. The options are Enabled and **Disabled** (for the Windows OS.).

**Intel® Virtualization Technology (Available when supported by the CPU)**

Select Enabled to use the feature of Virtualization Technology to allow one platform to run multiple operating systems and applications in independent partitions, creating multiple "virtual" systems in one physical computer. The options are **Enabled** and Disabled. **Note:** If there is any change to this setting, you will need to power off and restart the system for the change to take effect. Please refer to Intel's web site for detailed information.

**Execute Disable Bit (Available when supported by the OS and the CPU)**

Set to **Enabled** to enable the Execute Disable Bit to allow the processor to classify areas in the system memory where an application code can execute and where it cannot, thus preventing a worm or a virus from creating a flood of codes to overwhelm the processor or damage the system during an attack. The default is **Enabled**. (Refer to Intel and Microsoft Web Sites for more information.)

**Core-Multi-Processing (Available when supported by the CPU)**

Set to Enabled to use a processor's Second Core and beyond. (Please refer to Intel's web site for more information.) The options are Disabled and **Enabled**.

**Intel® Speed Step™ Technology (Available when supported by the CPU)**

Select Enabled to use the Enhanced Intel SpeedStep Technology and allow the system to automatically adjust the processor voltage and core frequency in an effort to reduce power consumption and heat dissipation. The options are **Enabled** and Disable.

**Intel® C-State Technology (Available when supported by the CPU)**

Select Enabled to use the Intel C-State Technology and allow the BIOS to automatically set the system power to C2/C3/C4 State in an effort to reduce power consumption and heat dissipation. The options are Enabled and **Disabled**.

**► Advanced Chipset Settings**

The items included in the Advanced Settings submenu are listed below:

**► NorthBridge Configuration**

This feature allows the user to configure the settings for the Intel 945GME NorthBridge chipset.

**Memory Remap Feature**

PCI memory resources will overlap with the total physical memory if 4GB of memory or above is installed on the motherboard. When this occurs, **Enable** this

function to reallocate the overlapped physical memory to a location above the total physical memory to resolve the memory overlapping situation. The options are **Enabled** and Disabled.

#### **PCI MMIO Allocation**

Use this feature to assign the address for PCI Memory-mapped IO (MMIO) allocation. The Default setting is **4 GB to 3200 MB**.

#### **DRAM Frequency**

This feature allows the user to select the DRAM Frequency setting. The options are **Auto (Auto-detect)**, 533 MHz, 667 MHz, 800 MHz, 1067 MHz and 1333 MHz

#### **Configure DRAM Timing by SPD**

Select Enable to allow the BIOS to read the SPD (Serial Presence Detect) chip which is built in the memory module in order to get the exact memory specifications. The options are **Enabled** and Disabled.

#### **Memory Hole**

Use the feature to allocate memory resource reserved for use of PCI devices. If set to 15 MB~16MB, the reserved memory will be placed in the location around 15 MB~16 MB. The options are **Disabled** and 15 MB~ 16 MB.

#### **Initiate Graphics Adapter**

Use this feature to select the graphics controller to be used as the primary boot device. The options are IGD, PCI/IGD, PCI/PEG, PEG/IGD, and **PEG/PCI**. See below for an explanation of the acronyms. For example, if PEG/PCI is selected, the system will look for a PCI-E graphics (PEG) adapter first, if none is found then it uses the PCI graphics (PCI) adapter to boot with.

PEG - **PCI-E Graphics** adapter (optional add-on card)

PCI - **PCI graphics** adapter (optional add-on card)

IGD - **Internal Graphics Display** (built-in)

#### **IGD Graphics Mode Select**

Use the feature to set the amount of system memory to be used by the Internal Graphics Devices. The options are Disabled, **Enabled 32 MB**, Enabled 64 MB, and Enabled 128 MB.

#### **IGD GTT Graphics Memory Size**

This feature allows the user to select the IGD GTT Graphics Size. The Default setting is **No VT Mode, 2 MB**.

### **PAVP Mode**

Use the feature to select the Protect Audio Video Path Mode. The options are **Disabled**, Lite, and Paranoid.

### **PEG Port Configuration**

#### **PEG Port (PCI-E Graphics Port)**

Use the feature to configure the PEG Port. The Default setting is **Auto** to allow the PEG Port to be automatically detected and configured by the BIOS.

## **▶Video Function Configuration**

### **DVMT Mode Select**

This is for informational purposes only and has been grayed-out. This item dynamically allocates video memory for optimal efficiency on 2D/3D video applications.

#### **DVMT/Fixed Memory**

This option allows the user to set the amount of memory to be used for the operation of DVMT/Fixed Mode. The options are 128 MB, **256 MB** and Maximum DVMT.

### **Flat Panel Type**

This option allows the user to select the Flat Panel Type. The options are Type 1~ Type 16. The default setting is **Type 3**.

### **Backlight Control Support**

This feature allows the user to determine how Backlight Control Support is managed by the system. The options are **VBIOS-Default**, Both BLC & BIA Disabled, and BLC Enabled.

### **BIA Control**

This feature allows the user to determine how the Video Adaptor's Burned-In-Address Control is managed by the system. The options are **VBIOS-Default**, BIA Disabled, BIA Enabled at Level 1, BIA Enabled at Level 2, BIA Enabled at Level 3, BIA Enabled at Level 4, and BIA Enabled at Level 5.

### TV Standard

This feature allows the user to determine how TV-Standard is handled by the system. The options are **VBIOS-Default**, NTSC, PAL, SECAM, SMPTE 240M, ITU-R-Television, SMPTE 295M, SMPTE 296M, EIA-770.2, and EIA-770.3.

### Spread Spectrum Clock

If Enabled, the BIOS will monitor the level of Electromagnetic Interference caused by the components and will attempt to decrease the interference whenever needed. The options are Enabled and **Disabled**.

### HDA Controller

Select Enabled to enable the High-Definition Audio Controller. The options are **Enabled** and Disabled.

### Intel VT-d

Select Enabled to enable Intel's Virtualization Technology support for Direct I/O VT-d by reporting the I/O device assignments to VMM through the DMAR ACPI Tables. This feature offers fully-protected I/O resource-sharing across the Intel platforms, providing the user with greater reliability, security and availability in networking and data-sharing. The settings are Enabled and **Disabled**.

### Active State Power Management

Select Enabled to enable Active-State Power Management for signal transactions between L0 and L1 Links on the PCI Express Bus in order to maximize power-saving and transaction speeds. The options are Enabled and **Disabled**.

### USB Functions

This feature allows the user to decide the number of onboard USB ports to be enabled. The Options are: Disabled, 2 USB ports, 4 USB ports, 6 USB ports, 8 USB ports, 10 USB ports, and **12 USB ports**.

### USB Port Configuration

This feature allows the user to configure the USB port settings. The options are **6 x 6** and 8 x 4.

### USB2.0 Controller

Select **Enabled** to activate the onboard USB2.0 controller. The options are **Enabled** and Disabled. Note: This function is not available if USB Functions above is set to more than 8 USB ports.

## ► USB Configuration

This feature allows the user to configure USB settings for the motherboard.

### USB Devices Enabled

This item displays the USB devices that are detected by the BIOS.

### Legacy USB Support

Select Enabled to use Legacy USB devices. If this item is set to Auto, Legacy USB support will be automatically enabled if a legacy USB device is installed on the motherboard, and vice versa. The settings are Disabled, Enabled and **Auto**.

### USB 2.0 Controller Mode

This setting allows you to select the USB 2.0 Controller mode. The options are Full Speed (12 Mbps), and **Hi-Speed (480 Mbps)**.

### BIOS EHCI Hand-Off

Select Enabled to enable BIOS Enhanced Host Controller Interface support to provide a workaround solution for an operating system that does not have EHCI Hand-Off support. When enabled, the EHCI Interface will be changed from the BIOS-controlled to the OS-controlled. The options are Disabled and **Enabled**.

### USB Beep Message

Select Enabled to activate a beep alarm when an error occurs on a USB device at bootup. The options are **Disabled** and Enabled.

## ► IDE Configuration Submenu

When this submenu is selected, the AMI BIOS automatically detects the presence of the IDE Devices and displays the following items:

### Floppy A

This feature allows the user to select the type of floppy drive connected to the system. The options are Disabled, 360KB 5 1/4", 1.2MB 5 1/4", 720KB 3 1/2", **1.44MB 3 1/2"** and 2.88MB 3 1/2".

### SATA#1 Configuration/SATA#2 Configuration

This feature allows the user to configure SATA#1/SATA#2 settings. The options for SATA1 are Disabled, **Compatible**, and Enhanced. The options for SATA2 are Disabled and **Enhanced**.

### **Primary IDE Master/Slave, Secondary IDE Master/Slave, Third IDE Master, Fourth IDE Master and Fifth IDE Master/Slave**

These settings allow the user to set the parameters of Primary IDE Master/Slave, Secondary IDE Master/Slave and Third IDE Master/Slave slots. Hit <Enter> to activate the following submenu screen for detailed options of these items. Set the correct configurations accordingly. The items included in the submenu are:

#### **Type**

Select the type of device connected to the system. The options are Not Installed, **Auto**, CD/DVD and ARMD (ATAPI Removable Media Device).

#### **LBA/Large Mode**

LBA (Logical Block Addressing) is a method of addressing data on a disk drive. In the LBA mode, the maximum drive capacity is 137 GB. For drive capacities over 137 GB, your system must be equipped with a 48-bit LBA mode addressing. If not, contact your manufacturer or install an ATA/133 IDE controller card that supports 48-bit LBA mode. The options are Disabled and **Auto**.

#### **Block (Multi-Sector Transfer)**

Block Mode boosts the IDE drive performance by increasing the amount of data transferred. Only 512 bytes of data can be transferred per interrupt if Block Mode is not used. Block Mode allows transfers of up to 64 KB per interrupt. Select Disabled to allow data to be transferred from and to the device one sector at a time. Select Auto to allow data transfer from and to the device occur multiple sectors at a time if the device supports it. The options are Disabled and **Auto**.

#### **PIO Mode**

The IDE PIO (Programmable I/O) Mode programs timing cycles between the IDE drive and the programmable IDE controller. As the PIO mode increases, the cycle time decreases. The options are **Auto**, 0, 1, 2, 3, and 4. Select Auto to allow the AMI BIOS to automatically detect the PIO mode. Use this value if the IDE disk drive support cannot be determined. Select 0 to allow the AMI BIOS to use PIO mode 0. It has a data transfer rate of 3.3 MBs. Select 1 to allow the AMI BIOS to use PIO mode 1. It has a data transfer rate of 5.2 MBs. Select 2 to allow the AMI BIOS to use PIO mode 2. It has a data transfer rate of 8.3 MBs. Select 3 to allow the AMI BIOS to use PIO mode 3. It has a data transfer rate of 11.1 MBs. Select 4 to allow the AMI BIOS to use PIO mode 4. It has a data transfer rate of 16.6 MBs. This setting generally works with all hard disk drives manufactured after 1999. For other disk drives, such as IDE CD-ROM drives, check the specifications of the drive.



### DMA Mode

Select **Auto** to allow the BIOS to automatically detect IDE DMA mode when the IDE disk drive support cannot be determined. Select **SingleWordDMA0** to allow the BIOS to use Single Word DMA mode 0. It has a data transfer rate of 2.1 MBs. Select **SingleWordDMA1** to allow the BIOS to use Single Word DMA mode 1. It has a data transfer rate of 4.2 MBs. Select **SingleWordDMA2** to allow the BIOS to use Single Word DMA mode 2. It has a data transfer rate of 8.3 MBs. Select **MultiWordDMA0** to allow the BIOS to use Multi Word DMA mode 0. It has a data transfer rate of 4.2 MBs. Select **MultiWordDMA1** to allow the BIOS to use Multi Word DMA mode 1. It has a data transfer rate of 13.3 MBs. Select **MultiWordDMA2** to allow the BIOS to use Multi Word DMA mode 2. It has a data transfer rate of 16.6 MBs. Select **UltraDMA0** to allow the BIOS to use Ultra DMA mode 0. It has a data transfer rate of 16.6 MBs. It has the same transfer rate as PIO mode 4 and Multi Word DMA mode 2. Select **UltraDMA1** to allow the BIOS to use Ultra DMA mode 1. It has a data transfer rate of 25 MBs. Select **UltraDMA2** to allow the BIOS to use Ultra DMA mode 2. It has a data transfer rate of 33.3 MBs. Select **UltraDMA3** to allow the BIOS to use Ultra DMA mode 3. It has a data transfer rate of 66.6 MBs. Select **UltraDMA4** to allow the BIOS to use Ultra DMA mode 4. It has a data transfer rate of 100 MBs. The options are **Auto**, **SingleWordDMA<sub>n</sub>**, **MultiWordDMA<sub>n</sub>**, and **UltraDMA<sub>n</sub>**.

### S.M.A.R.T.

Self-Monitoring Analysis and Reporting Technology (SMART) can help predict impending drive failures. Select **Auto** to allow the AMI BIOS to automatically detect hard disk drive support. Select **Disabled** to prevent the AMI BIOS from using the S.M.A.R.T. Select **Enabled** to allow the AMI BIOS to use the S.M.A.R.T. to support hard drive disk. The options are **Disabled**, **Enabled**, and **Auto**.

### 32-Bit Data Transfer

Select **Enabled** to enable 32-Bit data transfer. The options are **Disabled** and **Enabled**.

### Hard Disk Write Protect

Select **Enabled** to use the feature of Hard Disk Write Protect to prevent data from being written to HDD. The options are **Disabled** and **Enabled**.

### IDE Detect Time Out (Sec)

Use this feature to set the time-out value for the BIOS to detect the ATA, ATAPI devices installed in the system. The options are 0 (sec), 5, 10, 15, 20, 25, 30, and **35**.

### Hard Disk Detect Time Out

Use this feature to set the system time-out value to allow the BIOS to detect the HDD devices installed in the system. The options are Disabled, 1, 2, 3, 4, 5, 6, and 7 (seconds).

### ► PCI/PnP Configuration

This feature allows the user to set the PCI/PnP configurations for the following items:

#### Clear NVRAM

Select Yes to clear NVRAM during system boot. The options are **No** and Yes.

#### Plug & Play OS

Select Yes to allow the OS to configure Plug & Play devices. (This is not required for system boot if your system has an OS that supports Plug & Play.) Select **No** to allow the AMI BIOS to configure all devices in the system.

#### PCI Latency Timer

This feature sets the latency Timer of each PCI device installed on a PCI bus. Select **64** to set the PCI latency to 64 PCI clock cycles. The options are 32, **64**, 96, 128, 160, 192, 224 and 248.

#### Allocate IRQ to PCI VGA

Select Yes to allow the system to give the VGA adapter card an interrupt address. The options are **Yes** and No.

#### Palette Snooping

Select Enabled to inform the onboard PCI devices that an ISA graphics device is installed in the system in order for the graphics card to function properly. The options are **Disabled** and Enabled.

#### PCI IDE BusMaster

Select Enabled to allow the BIOS to use the PCI busmaster to read from and write to the onboard IDE drives. The options are Disabled and **Enabled**.

#### PCI Slot 1, 2, 4, 6, 7

Select **Yes** to enable OPROM for a PCI slot specified. The options are **Yes** (to enable OPROM for the slot specified) and No.

#### Load Onboard LAN Option ROM

Select Enabled to load the onboard LAN Option ROM. The options are Enabled and **Disabled**.

---

## ► Super IO Configuration

### Serial Port1 Address

This option specifies the base I/O port address and the Interrupt Request address of Serial Port 1. Select Disabled to prevent the serial port from accessing any system resources. When this option is set to Disabled, the serial port physically becomes unavailable. Select 3F8/IRQ4 to allow the serial port to use 3F8 as its I/O port address and IRQ 4 for the interrupt address. The options are Disabled, 2F8/IRQ3, **3F8/IRQ4**, 3E8/IRQ4, 2E8/IRQ3.

### Parallel Port I/O Address

This item allows the user to select the base I/O address for the parallel port. The options are Disabled, **378**, 278 and 3BC.

### Parallel Port Mode

This feature allows the user to specify the parallel port mode. The options are **Normal**, Bi-Directional, ECP, EPP, ECP & EPP.

### Parallel Port IRQ

This setting allows the to select the IRQ (interrupt request) for the parallel port. The options are IRQ5 and **IRQ7**.

## ► Hardware Health Configuration

This feature allows the user to monitor Hardware Health of the system and review the status of each item when displayed.

### CPU Overheat Alarm

This option allows the user to select the CPU Overheat Alarm setting which determines when the CPU OH alarm will be activated to provide warning of possible CPU overheat.



**Warning:** Any temperature that exceeds the CPU threshold temperature predefined by the CPU manufacturer may result in CPU overheat or system instability. When the CPU temperature reaches this predefined threshold, the CPU and system cooling fans will run at full speed.

The options are:

The Early Alarm: Select this setting if you want the CPU overheat alarm (including the LED and the buzzer) to be triggered as soon as the CPU temperature reaches the CPU overheat threshold as predefined by the CPU manufacturer.

**The Default Alarm:** Select this setting if you want the CPU overheat alarm (including the LED and the buzzer) to be triggered when the CPU temperature reaches about 5°C above the threshold temperature as predefined by the CPU manufacturer to give the CPU and system fans additional time needed for CPU and system cooling.

### CPU Temperature,

### System Temperature

### Fan Speed Control Modes

This feature allows the user to decide how the system controls the speeds of the onboard fans. The CPU temperature and the fan speed are correlative. When the CPU on-die temperature increases, the fan speed will also increase, and vice versa. Select Workstation if your system is used as a Workstation. Select Server if your system is used as a Server. Select Disabled to disable the fan speed control function and allow the onboard fans to constantly run at the full speed (12V). The Options are: **Disabled**, 4-pin (Super Quiet), and 4-pin (Workstation).

### Fan Speeds:

The BIOS will automatically display the speed of the fans indicated in this item, in RPMs.

### Voltage Monitoring

Vcore, AVcc, +3.3Vcc, +12V, V\_DIMM, +5V, -12V, 3.3VStandby, and Vbatt.



**Note:** In the Windows OS environment, the Supero Doctor III settings take precedence over the BIOS settings. When first installed, Supero Doctor III adopts the temperature threshold settings previously set in the BIOS. Any subsequent changes to these thresholds must be made within Supero Doctor, since the SD III settings override the BIOS settings. For the Windows OS to adopt the BIOS temperature threshold settings, please change the SDIII settings to be the same as those set in the BIOS.

## 4-4 Security Settings

The AMI BIOS provides a Supervisor and a User password. If you use both passwords, the Supervisor password must be set first.



### Supervisor Password:

This item indicates if a supervisor password has been entered for the system. Clear means such a password has not been used and Set means a supervisor password has been entered for the system.

### User Password:

This item indicates if a user password has been entered for the system. Clear means such a password has not been used and Set means a user password has been entered for the system.

### Change Supervisor Password

Select this option and press <Enter> to access the submenu, and then type in a new Supervisor Password.

### User Access Level (Available when Supervisor Password is set as above)

Available options are **Full Access**: grants full User read and write access to the Setup Utility, **View Only**: allows access to the Setup Utility but the fields cannot be changed, **Limited**: allows only limited fields to be changed such as Date and Time, **No Access**: prevents User access to the Setup Utility.

### Change User Password

Select this option and press <Enter> to access the submenu, and then type in a new User Password.

**Clear User Password (Available only if User Password has been set)**

Use this option to clear the User Password. The options are **OK** and **Cancel**.

**Password Check**

Use this option to configure when users are prompted for a password. Available options are **Setup** and **Always**.

Setup - Ask for password before granting access to the BIOS setup utility only.

Always - Ask for password before granting access to the BIOS setup utility and each time the system boots.

**Boot Sector Virus Protection**

This option is near the bottom of the Security Setup screen. When Enabled, the AMI BOIS displays a warning when any program (or virus) issues a Disk Format command or attempts to write to the boot sector of the hard disk drive. The options are Enabled and **Disabled**.

## 4-5 Boot Configuration



Use this feature to configure Boot Settings:

### ► Boot Device Priority

This feature allows the user to specify the sequence of priority for the Boot Device.

The settings are 1st Floppy Drive and Disabled. The default settings are the following:

- 1st Boot Device – 1st Floppy Drive
- 2nd Boot Device - SATA

### ► Hard Disk Drives

This feature allows the user to specify the boot sequence from available Hard Disk Drives.

- 1st Drive - SATA

### ► Removable Drives

This feature allows the user to specify the boot sequence from available Removable Drives.

- 1st Drive

## 4-6 Exit Options

Select the Exit tab from the AMI BIOS Setup Utility screen to enter the Exit BIOS Setup screen.

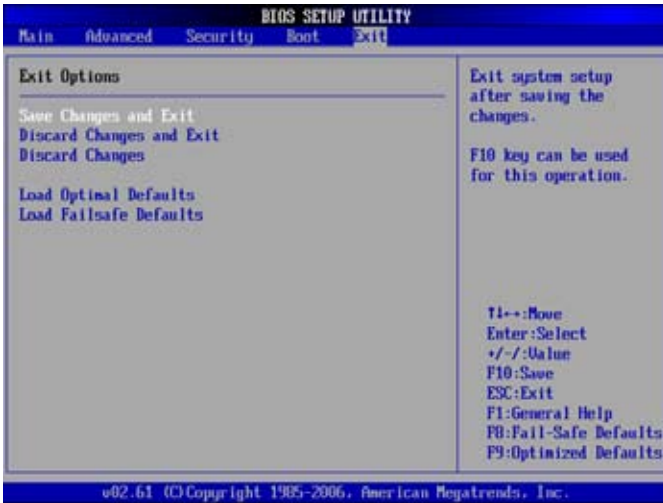

### Save Changes and Exit

When you have completed the system configuration changes, select this option to leave the BIOS Setup Utility and reboot the computer, so the new system configuration parameters can take effect. Select Save Changes and Exit from the Exit menu and press <Enter>.

### Discard Changes and Exit

Select this option to quit the BIOS Setup without making any permanent changes to the system configuration, and reboot the computer. Select Discard Changes and Exit from the Exit menu and press <Enter>.

### Discard Changes

Select this option and press <Enter> to discard all the changes and return to the AMI BIOS Utility Program.

### Load Optimal Defaults

To set this feature, select Load Optimal Defaults from the Exit menu and press <Enter>. Then, select OK to allow the AMI BIOS to automatically load Optimal Defaults to the BIOS Settings. The Optimal settings are designed for maximum system performance, but may not work best for all computer applications.



**Load Fail-Safe Defaults**

To set this feature, select Load Fail-Safe Defaults from the Exit menu and press <Enter>. The Fail-Safe settings are designed for maximum system stability, but not for maximum performance.

## Notes

## Appendix A

### BIOS Error Beep Codes

During the POST (Power-On Self-Test) routines, which are performed each time the system is powered on, errors may occur.

**Non-fatal errors** are those which, in most cases, allow the system to continue the boot-up process. The error messages normally appear on the screen.

**Fatal errors** are those which will not allow the system to continue the boot-up procedure. If a fatal error occurs, you should consult with your system manufacturer for possible repairs.

These fatal errors are usually communicated through a series of audible beeps. The numbers on the fatal error list, on the following page, correspond to the number of beeps for the corresponding error.

| BIOS Error Beep Codes                              |                                 |  |
|--|---------------------------------|--|
| Beep Code  | Error Message                   | Description                                      |
| 1 beep   | Refresh                         | Circuits have been reset.<br>(Ready to power up) |
| 5 short beeps, 1 long beep                         | Memory error                    | No memory detected in the system                 |
| 8 beeps  | Display memory read/write error | Video adapter missing or with faulty memory      |
| 1 continuous beep (with the front panel OH LED on) | System Overheat                 | 1 continuous beep with the front panel OH LED on |

## Notes

## Appendix B

### Installing the Windows OS

#### Installing the Windows XP/2000/2003 OS

1. Insert Microsoft's Windows XP/2000/2003 Setup CD in the CD Drive, and the system will start booting up from CD.
2. Press the <F6> key when the message-" Press F6 if you need to install a third party SCSI or RAID driver" displays.
3. When the Windows XP/2000/2003 Setup screen appears, press "S" to specify additional device(s).
4. Press the <Enter> key to proceed with the installation process. (If you need to specify any additional devices to be installed, do it at this time.) Once all devices are specified, press the <Enter> key to continue with the installation.
5. From the Windows XP/2000/2003 Setup screen, press the <Enter> key. The XP/2000/2003 Setup will automatically load all device files and then continue with the Windows XP/2000/2003 installation.
6. After the Windows XP/2000/2003 OS Installation is completed, the system will automatically reboot.
7. Insert the Supermicro Setup CD that came with your motherboard into the CD Drive during system boot, and the main screen as shown on Page C-1 will display. Follow the instructions given in Appendix C to complete other software/driver installation.

## Notes

## Appendix C

### Software Installation Instructions

#### C-1 Installing Drivers

After you've installed the Windows Operating System, a screen as shown below will appear. You are ready to install software programs and drivers that have not yet been installed. To install these software programs and drivers, click the icons to the right of these items.



**Driver/Tool Installation Display Screen**



**Note:** Click the icons showing a hand writing on the paper to view the readme files for each item. Click a computer icon to the right of an item (from top to the bottom) one at a time. After installing each item, you must re-boot the system before proceeding with the next item on the list. The bottom icon with a CD on it allows you to view the entire contents of the CD.

## C-2 Configuring Supero Doctor III

The Supero Doctor III program is a Web-base management tool that supports remote management capability. It includes Remote and Local Management tools. The local management is called the SD III Client. The Supero Doctor III program included on the CDROM that came with your motherboard allows you to monitor the environment and operations of your system. Supero Doctor III displays crucial system information such as CPU temperature, system voltages and fan status. See the Figure below for a display of the Supero Doctor III interface.



**Note 1:** Both default user name and password are ADMIN.

**Note 2:** In the Windows OS environment, the Supero Doctor III settings take precedence over the BIOS settings. When first installed, Supero Doctor III adopts the temperature threshold settings previously set in the BIOS. Any subsequent changes to these thresholds must be made within Supero Doctor, since the SD III settings override the BIOS settings. For the Windows OS to adopt the BIOS temperature threshold settings, please change the SDIII settings to be the same as those set in the BIOS.

### Supero Doctor III Interface Display Screen-I (Health Information)





**Supero Doctor III Interface Display Screen-II (Remote Control)**

**Note:** SD III Software Revision 1.0 can be downloaded from our Web site at: [ftp://ftp.supermicro.com/utility/Supero\\_Doctor\\_III/](ftp://ftp.supermicro.com/utility/Supero_Doctor_III/). You can also download SDIII User's Guide at: <http://www.supermicro.com/PRODUCT/Manuals/SDIII/UserGuide.pdf>. For Linux, we will still recommend that you use Supero Doctor II.

## Notes

---

---

## Appendix D - BIOS Recovery

The recovery procedure described in this section is to be used only when advised by your Supermicro Technical Support representative, or in cases of emergencies where the system no longer can boot due to a corrupted BIOS. DO NOT re-program (re-flash) the BIOS if your system is running properly.

### D-1 Recovery Process from a USB Device/Drive (Recommended Method)

If the BIOS file is corrupted and the system is not able to boot up, this feature will allow you to recover the BIOS image using a USB-attached device. A USB Flash Drive or a USB CD/DVD ROM/RW drive may be used for this purpose. Please note that a USB Hard Disk drive is NOT supported at this time and only COM1 is recognized by the recovery program. Below is a two-part procedure to recover the BIOS:

#### Part 1: Boot Sector Recovery Process

1. Using a different system, download and copy the correct BIOS binary image into a USB flash device or a writable CD/DVD disc's Root "" Directory. Rename the downloaded file to "super.rom", so the recovery process can recognize and read the BIOS binary file.
2. Insert the USB device that contains the new BIOS binary image ("super.rom") and power the system down.
3. While powering on the system, press and hold <Ctrl> and <Home> simultaneously on your keyboard until the USB device's LED indicator comes on. This will take a few seconds or up to one minute.
4. Once the USB device's LED is on, release the <Ctrl> and <Home> keys. The system may generate beep codes to indicate that the BIOS ROM firmware is being reprogrammed. The screen will also display a message as shown below. DO NOT INTERRUPT THIS PROCESS!

```
Starting FLASH Recovery.  
NVRAM data will be destroyed.  
CMOS data will be destroyed.  
.....  
.....  
Ending FLASH Recovery.  
FLASH Update completed successfully.  
Rebooting...
```

5. When the Boot Sector Recovery Process is complete, the system will reboot automatically and you will see a checksum error on your screen.

## Part 2 - BIOS Reprogramming (Re-Flashing)

After completing the Boot Sector Recovery Process, you will need to reprogram ("re-flash") the proper BIOS binary file again into the BIOS ROM in order to have the correct BIOS file loaded by the system. For details on how to flash/re-flash a BIOS, please check our website for "Update your BIOS", or see the section 3-3 (FAQ) of this manual. DO NOT INTERRUPT THIS PROCESS!

When completed, the system will reboot automatically, and you will see a checksum error again.

Press "F1" to go to setup. Press "F9" to load the defaults and then press "F10" to save and exit.

## D-2 Recovery Process from an IDE/SATA ATAPI Disc Drive

This process is identical to the Boot Sector Recovery Process from a USB Device/Drive (as above), except that the BIOS image file ("super.rom") is loaded from an IDE/ATAPI CD/DVD-ROM/RW disc drive that is attached to the system. Note that loading from an IDE/SATA hard disk drive is NOT supported.

1. Using a different system, download and copy the correct BIOS binary image into a writable CD/DVD disc's Root "\" Directory. Rename the downloaded file to "super.rom", so the recovery process can recognize and read the BIOS binary file.



**Note:** Record/Burn the CD/DVD-R/RW disc using the ISO 9600 standard format. Refer to your CD/DVD mastering application documentation for instructions on how to do this.

2. Insert the newly-created disc into the IDE/SATA ATAPI CD/DVD ROM/RW drive of the system that has the corrupted BIOS and power the system down.
3. Follow the step-by-step instructions under Part 1 - Recovery Process from a USB Device/Drive (above) starting from Step 3 and continue on to Part 2 - BIOS Reprogramming (Re-Flashing).

If your system still does not boot up after performing the above procedure, then there may be other issues with your motherboard. Please contact your customer service representative.

(Disclaimer continued)

The products sold by Supermicro are not intended for and will not be used in life support systems, medical equipment, nuclear facilities or systems, aircraft, aircraft devices, aircraft/emergency communication devices or other critical systems whose failure to perform be reasonably expected to result in significant injury or loss of life or catastrophic property damage. Accordingly, Supermicro disclaims any and all liability, and should buyer use or sell such products for use in such ultra-hazardous applications, it does so entirely at its own risk. Furthermore, buyer agrees to fully indemnify, defend and hold Supermicro harmless for and against any and all claims, demands, actions, litigation, and proceedings of any kind arising out of or related to such ultra-hazardous use or sale.