

CONTENT

Item Checkup	7
Chapter 1 Specification	8
1-1 Mainboard Layout	9
1-2 Mainboard Specifications	10
1-2.1 CPU Socket	10
1-2.2 System Chipset Architecture	10
1-2.3 Memory Slot	10
1-2.4 BIOS (Basic Input Output System)	10
1-2.5 Hardware Monitoring	11
1-2.6 Multi-I/O Function	11
1-2.7 Expansion Slots	11
1-2.8 Accelerated Graphics port (AGP) Interface	11
1-2.9 FORM FACTOR	11
1-2.10 AC'97 Audio Codec on board	12
1-2.11 Power Management	12
1-3 Mainboard Specification Table	13
1-4 Chipset System Block Diagram	14
Chapter 2 Hardware Setup	16
2-1 Pentium 4 CPU and Installation	17
2-1.1 To Identify a Pentium 4 CPU	17
2-1.2 Pentium 4 CPU Installation with Socket 478	18
2-2 Pentium 4 CPU Fan Installation:	19
2-3 Memory Installation	20
2-3.1 To Install DIMM Module	20
2-3.2 To Remove a DIMM:	20
2-4 Install AGP4X with LED & Jumper Safeguard	21

2-5 IDE Connector Installation	22
2-6 FDC (Floppy Drive Connector) Installation	23
2-7 ATX V 2.03 Power Supply Installation	24
2-8 Jumper Settings	25
2-8.1 How to tackle the Jumpers:	26
2-8.2 Jp2: FSB (Front Side Bus) Select	26
2-8.3 JBAT1 : Clear CMOS	27
2-8.4 JP3: AGP 4X Safeguard	28
2-8.5 JP4 & JP5: DIMM Voltage Select (optional)	28
2-8.6 JAGP1 & JAGP2: AGP Voltage Select (optional)	29
2-8.7 Jp1: PS/2 KB/Mouse Power On	29
2-9 Other Connectors Configuration	30
2-9.1 On Board Fan Connectors	30
2-9.2 WOL1: Wake On LAN	31
2-9.3 CD-ROM Audio Connector CD8	31
2-9.4 RT1 & RT2: Thermal Resistor and Connector	32
2-9.5 Complex Header	33
2-9.6 USB Ports and USB Header	35
2-9.7 Chassis Panel Connector	36
2-9.8 PS/2 Mouse and PS/2 Keyboard	36
2-9.9 CN19: Front Panel Audio Connector (optional)	36
Chapter 3 Software Setup	38
3-1 Open up the Support CD	39
3-2 To Install “Intel Chipset Software Installation Utility”	40
3-3 To Install “Intel Application Accelerator”	41
3-4 To Install AC'97 Audio Driver	43
3-5 To Install Hardware Monitor Utility	44
3-5.1 Installation	44
3-5.2 Verification	45

Chapter 4 AMI BIOS Setup	46
4-1 About BIOS Setup	47
4-2 To Run BIOS Setup	47
4-3 About CMOS	47
4-4 The POST (Power On Self Test)	47
4-5 To Update BIOS	48
4-5.1 Before Update BIOS	48
4-5.2 Update Process	48
4-6 BIOS SETUP --- CMOS Setup Utility	50
4-6.1 CMOS Setup Utility	50
4-6.2 Standard CMOS Setup	51
4-6.3 Advanced BIOS Features	54
4-6.4 Advanced Chipset Features	57
4-6.5 Power Management Features	60
4-6.6 PNP / PCI Configurations	63
4-6.7 Integrated Peripherals	65
4-6.8 Hardware Monitor Status	68
4-6.9 Frequency/Voltage Control	70
4-6.10 Set Supervisor Password	72
4-6.11 Load Optimized Defaults	73
4-6.12 Save & Exit Setup	73
4-6.13 Exit Without Saving	74
APPENDICES	76
Appendix-1 Identify Mainboard Model Number	77
Appendix-2 Technical Terms	78

Item Checkup

- Mainboard
- Support CD
- Bundled Bonus Pack CD
- Bundled Bonus Pack Manual
- User Manual (Mainboard)
- Multi-lingual Quick Installation Guide
- Thermal Sensor Cable ([Optional](#))
- ATA66/100 IDE Cable
- FDD Cable

Chapter 1 Specification

Introduction

This series features an integration of the powerful processor Intel Pentium 4 and the single-chip North Bridge Intel 845D/845E. The Intel P4 processor is a rapid execution engine providing 533/400MHz system bus, while North Bridge Intel 845D/845E is a high performance integrated chipset providing DDR 266 SDRAM memory interface, Hub interface, and AGP interface.

Integrated with i845D/845E, South Bridge Intel ICH2 supports the LPC Super I/O, upstream Hub interface, PCI interface, IDE interface, USB 1.1 interface, AC'97 2-channel Audio interface and the interrupt control. This chapter introduces to users every advanced function of this high performance integration.

The topics contained in this chapter are:

1-1 Mainboard Layout

1-2 Mainboard Specifications**

1-3 Mainboard Specification Table

1-4 Chipset System Block Diagram

**** If any difference is found between the manual description and the Mainboard you are using, please look up the ERRATA/UPDATE Slip enclosed inside for the correction or updated information, or else contact the Mainboard Dealer or visit our Web Site for the latest manual update.**

1-1 Mainboard Layout

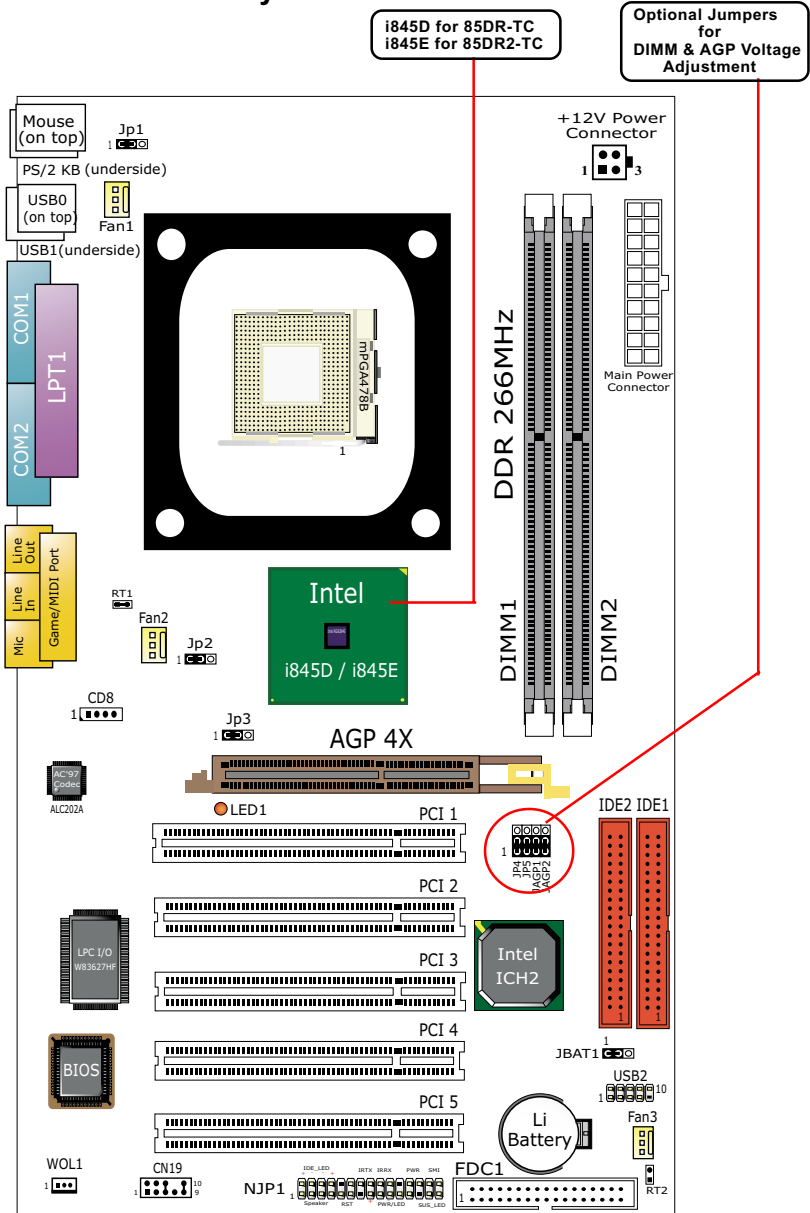

1-2 Mainboard Specifications

1-2.1 CPU Socket

CPU Socket 478B on board, supporting Intel® Pentium 4 processor (including Intel Hyper-Threading CPUs) in the 478-pin package for:

- 533/400MHz System Bus;Hyper-pipelined technology
- Advanced dynamic execution;Advanced transfer cache

1-2.2 System Chipset Architecture

- North Bridge Intel 845D/845E: a high performance integrated chipset working with Intel Pentium 4 Processor for managing and arbitrating between 4 interfaces:
 - the System Bus (Host Interface)
 - the memory interface
 - the AGP Port and the Hub interface
- For 85DR-TC, North Bridge is 845D, supporting FSB400 and FSB533 overclocking, Intel HT CPUs supported with HT Logo on Bootup screen
- For 85DR2-TC, North Bridge is 845E, supporting 533MHz / 400MHz FSB officially, Intel HT CPUs supported with HT Logo on Bootup screen
- South Bridge Intel ICH2 Chipset: communicating with Intel 845D/E by the Hub interface at 66MHz/266MB/s; supporting the LPC I/O, PCI Interface, IDE interface, USB 1.1 interface, AC'97 Audio interface as well as the interrupt control

1-2.3 Memory Slot

2 x DDR DIMM 184-pin slot on board for DDR 266 SDRAMs, supported by 2.5V default voltage (DIMM Voltage Adjustment optional):

- supporting unregistered, ECC DDR 266 SDRAM up to 2GBs capacity
- Supporting installation of mixed volumes yet same type of DDR SDRAM

1-2.4 BIOS (Basic Input Output System)

Flash Memory for easy upgrade, supporting BIOS Writing Protection, Year 2000 compliant, and various hardware configuration during system boot-up (See Chapter 4 BIOS Setup):

- Standard CMOS Features (Times, Date, Hard Disk Type etc.)
- Advanced BIOS Features (Virus Protection, Boot Sequence etc.)
- Advanced Chipset Features (AT Clock, DRAM Timing etc.)
- Power Management Features (Sleep timer, Suspend Timer etc.)
- PNP/PCI Configurations (IRQ Settings, Latency Timers etc.)
- Integrated Peripherals (Onboard IO,IRQ, DMA Assign. etc.)
- Hardware Monitor Status (CPU/System Temp.,Fan speed etc.)
- Frequency/Voltage (CPU clock, Voltage of CPU, DIMM, AGP etc.)

1-2.5 Hardware Monitoring

- Programmable status control, providing monitoring and alarm for flexible desktop management of hardware temperatures. Monitor Utility is enclosed in Support CD for user's installation.

1-2.6 Multi-I/O Function

- PCI EIDE Controller, supporting:
 - 2 Ultra ATA100 / 66 / 33 Connectors
- UARTs (Universal Asynchronous Receiver/Transmitter):
 - 2 UARTs for Complete Serial Ports (COM1 & COM2)
- Dedicated IR Connector:
 - Third serial port dedicated to IR function either through the two complete serial ports or the third dedicated port Infrared-IrDA (HPSIR) and ASK (Amplitude Shift Keyed) IR
- Multi-mode parallel Connector:
 - Standard mode, high speed ECP and enhanced mode EPP
- Floppy Disk Connector:
 - 1 FDD connector with drive swap support
- Universal Serial Bus Connector:
 - USB V1.1 compliant
 - 2 built-in USB ports and 1 USB Header which requires a USB cable to support 2 additional USB ports
- PS/2 Keyboard Connector
- PS/2 Mouse Connector

1-2.7 Expansion Slots

- 5 PCI bus Master slots
- 1 AGP 4X slot
- 2 DDR DIMM slots

1-2.8 Accelerated Graphics port (AGP) Interface

One AGP slot on board supported by the Intel 845D/E Chipset MCH AGP Interface in 1.5V mode (optional AGP voltage adjustment):

- 4X AD and SBA signaling, AGP pipelined split-transaction longburst transfers up to 1GB/sec.
- AGP v2.0 compliant

1-2.9 FORM FACTOR

- ATX Form Factor
- This series is compatible only with ATX Power Supply Version 2.03 (with +12V Power Connector)
- Mainboard size: 305mm x 180mm

1-2.10 AC'97 Audio Codec on board

AC'97 Audio Codec on board

- Supporting 2-channel PCM audio output
- AC'97 Audio Codec Driver enclosed in Support CD for user's installation

1-2.11 Power Management

- ACPI 1.0B compliant (Advanced Configuration and Power Interface)
- APM V1.2 compliant (Legacy Power Management)
- Supporting ACPI suspend POS mode (Power On Suspend)
- PS/2 Keyboard/Mouse Power On
- Supporting Wake On LAN (WOL)
- Supporting real time clock (RTC) with date alarm, month alarm, and century field.

1-3 Mainboard Specification Table

SL-85DR2-TC/85DR-TC Specifications and Features	
CPU Socket	Socket 478B for P4 CPU, HT CPUs included
*North Bridge	*Intel 845D/845E, supporting 533/400MHz FSB
South Bridge	Intel ICH2
BIOS	AMI BIOS
Memory Slot	Supporting DDR 266/200 SDRAM, up to 2GB in two DDR DIMM slots
I/O Chip	W83627HF, with Hardware Monitor integrated
AGP interface	AGP 4X mode only
Audio	AC'97 Audio 2.1 compliant, 2-channel audio
IDE Interface	2 UATA 66/100 IDE ports
PCI Slots	5 PCI Master slots on board
I/O Connectors	4 USB V1.1, 1 FDD port, 2 COM ports, 1 LPT, 1 IrDA, 1 PS/2 K/B, 1 PS/2 Mouse
Other common features	BIOS Writing Protection PS/2 Keyboard/Mouse Power On ATX 2.03 Power Supply ATX form factor

- * • For 85DR-TC, North Bridge is 845D, supporting FSB400 and FSB533MHz overclocking.
- For 85DR2-TC, North Bridge is 845E, supporting 533MHz / 400MHz FSB officially.

1-4 Chipset System Block Diagram

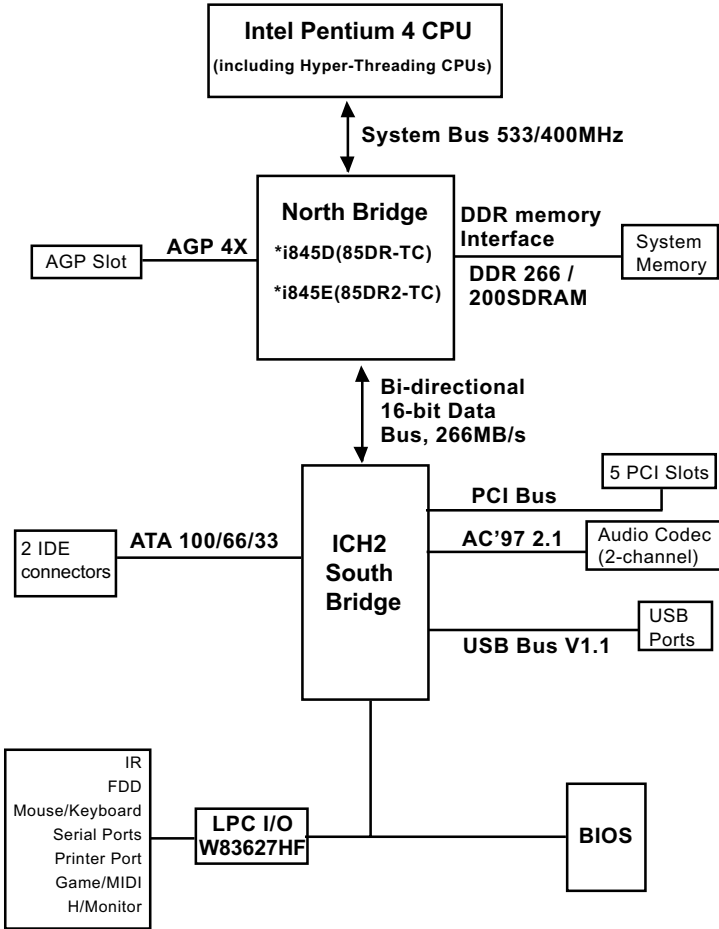

Pentium 4 + Intel 845D/845E + Intel ICH2 Diagram

- * • For 85DR-TC, North Bridge is 845D, supporting FSB400 and FSB533 overclocking.
- For 85DR2-TC, North Bridge is 845E, supporting 533MHz / 400MHz FSB officially.

Chapter 2 Hardware Setup

To Get Things Ready for Hardware Setup !!!

1. We recommend to install your CPU before any other components. For detailed installation instructions of processor, you can also refer to the pamphlet enclosed in your CPU package.
2. Installing a cooling fan with a good heatsink is a must for proper heat dissipation for your CPU. Get ready an appropriate fan with heatsink for proper installation. Improper fan and installation will damage your CPU.
3. In case CPU Vcore, CPU clock or Frequency Ratio is adjustable onboard, please follow the instructions described in the User manual for proper setup. Incorrect setting will cause damage to your CPU.

The following topics are included in this chapter:

2-1 Pentium 4 CPU and Installation

2-2 Pentium 4 CPU Fan Installation

2-3 Memory Installation

2-4 AGP 4X (Accelerated Graphics Port) Installation

2-5 HDD Installation

2-6 FDD Installation

2-7 ATX Power Supply Installation

2-8 Jumper and Switch Settings

2-9 Other Connectors Configuration

2-1 Pentium 4 CPU and Installation

2-1.1 To Identify a Pentium 4 CPU

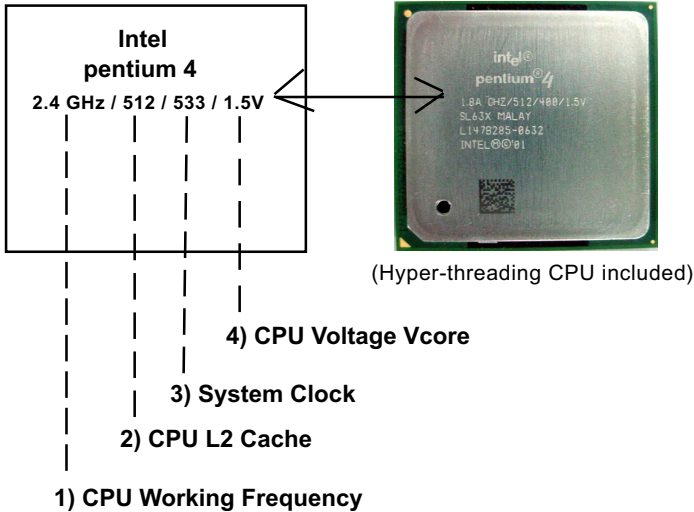

On the heatsink side of a Pentium 4 CPU, there printed a line of figures to identify its specifications. The line consists of 4 parts:

1. CPU Working Frequency: this part depicts the working frequency of the CPU. For example,
 - 2.4 GHz depicts that this CPU is locked to 2.4 GHz working frequency (18 x 133MHz CPU clock);
 - 2A GHz depicts that this CPU is an A version, locked to 2.0 GHz working frequency (20 x 100MHz CPU clock)
 - 3.06GHz depicts that this is a 3.06GHz hyper-threading CPU
2. CPU L2 Cache: this part depicts the L2 Cache size. For example,
 - 512 stands for 512 KB L2 Cache; 256 stands for 256 KB L2 Cache
3. System Clock: this part depicts the System Clock (Front Side Bus) provided by the CPU. For example,
 - 533 stands for a 533MHz system clock provided by a 133MHz CPU times 4;
 - 400 stands for a 400 system clock provided by a 100 MHz CPU x 4.
4. CPU Voltage Vcore: this part depicts the CPU Voltage. For example,
 - 1.5V stands for a CPU of 1.5V Vcore.

Note: System Clock vs CPU Clock

P4 CPU is a quadpumped CPU. The system bus is provided by the CPU clock x 4. Therefore, users can figure out the P4 CPU clock by the System Clock divided by 4.

2-1.2 Pentium 4 CPU Installation with Socket 478

This series is built with CPU Socket 478B (478-pin) supporting the Intel Pentium 4 CPU:

- Follow the steps described in this section to install the 478-pin Pentium 4 CPU into the on board Socket 478.
- After installation of Pentium 4 CPU, you must also install the specific Pentium 4 CPU fan designed in tandem with this CPU. This CPU Fan installation is described in next section.
- This series supports Hyper-threading dual-in-one CPU, the function of which can be enabled by Windows XP. (See illustration on the right.)

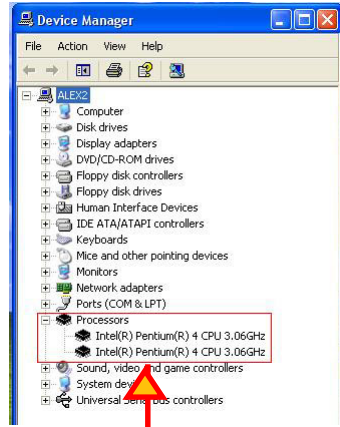

(If Hyper-threading CPU is installed successfully with O/S Win XP, the O/S will enable the dual-in-one CPU function.)

1. First pull sideways the lever of Socket 478, and then turn it up 90° so as to raise the upper layer of the socket from the lower platform.

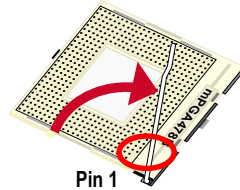

2. Configure Pin 1 of CPU to Pin 1 of the Socket, just as the way shown in the diagram on the right. Adjust the position of CPU until you can feel all CPU pins get into the socket with ease.

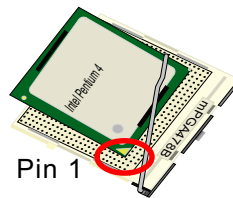

3. Make sure that all CPU pins have completely entered the socket and then lower down the lever to lock up CPU to socket.

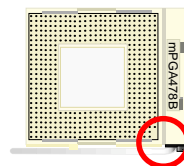

2-2 Pentium 4 CPU Fan Installation:

Pentium 4 Fan Base

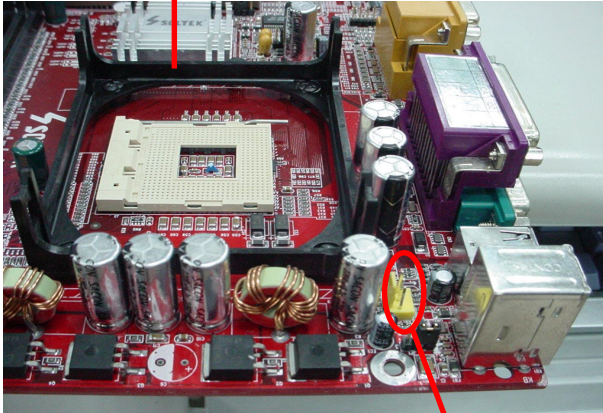

Fan Connector

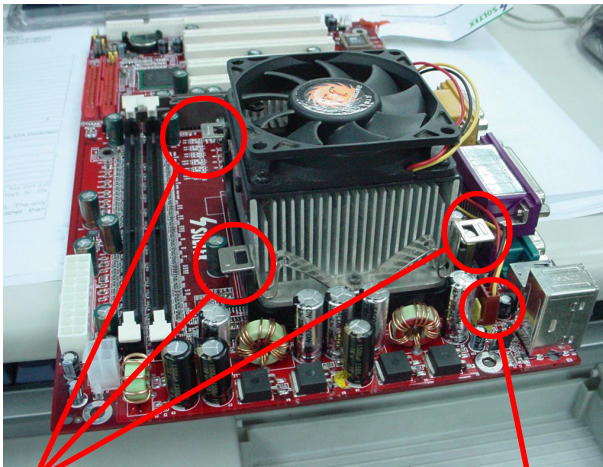

Press down 4 latches to lock fan to fan base

Connect to CPU Fan connector

2-3 Memory Installation

How to tackle the memory modules:

- Make sure to unplug your power supply before adding or removing memory module. Failure to do so may cause severe damage to both your mainboard and the memory module.
- Pay attention to the orientation of the DIMM slots. Forcing a DIMM into a slot improperly will damage the memory module and the slot itself.
- Make sure you have the right type of memory module for your mainboard.

2-3.1 To Install DIMM Module

- This series only supports up to 2GB unbuffered DDR 266/200MHz SDRAM, with 2 DDR DIMM slots on board. Do not insert other type of memory module into these slots.
- DDR DIMM slot has 184-pins and one notch. Insert a DDR SDRAM vertically into the 184-pin slot with the notch-to-rib matching. Press the module down in a gradual way until it surely reaches the bottom and clicks straight up the two latches on the left and right of the slot. If any one of the latches has not turned up completely, you should unplug the module and press it down the slot a bit more firmly.

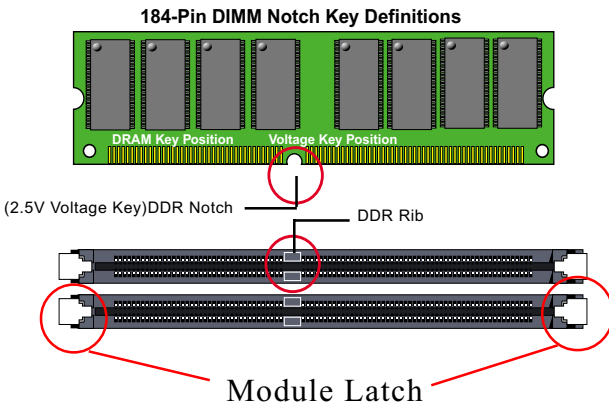

2-3.2 To Remove a DIMM:

- Press down the holding latches on both sides of the DIMM slot and the module will be released from it.

2-4 Install AGP4X with LED & Jumper Safeguard

1. The AGP slot on board supports only AGP 4X card configuration. Users should install an 1.5V AGP 4X card.
2. A safe installation of AGP 4X card is to set Jp3 to 1-2 closed, resulting in allowing only 1.5V AGP 4X card to boot system. In this case, if users cannot boot with an AGP card inserted in the slot, it indicates that the AGP card is not a correct one. The card should be replaced with a 1.5V AGP 4X card.
3. LED1 is a Warning LED. Whenever JP3 is set 1-2 closed for an AGP 4X card installation, and yet the AGP slot is left empty, or the card is not a correct one, LED1 will light up until a proper installation is done.

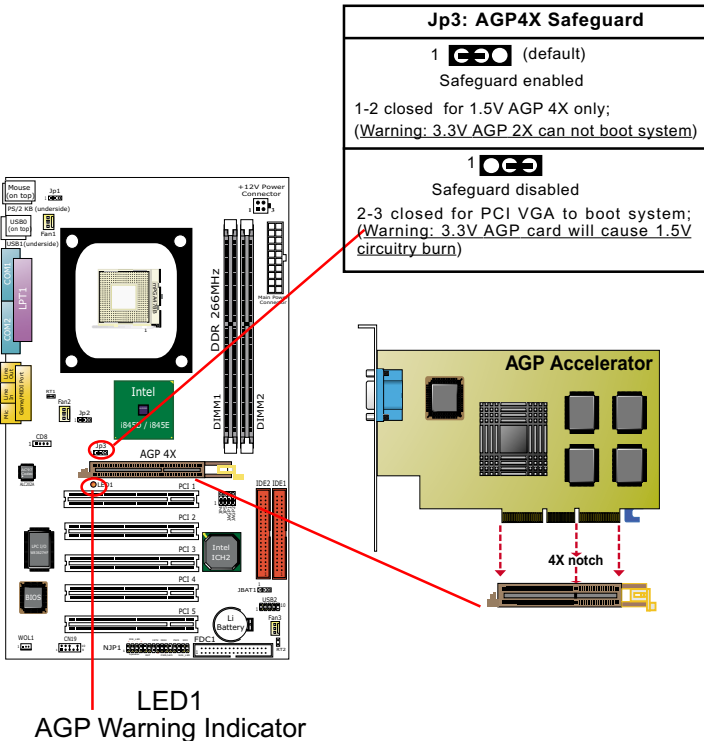

2-5 IDE Connector Installation

To install HDD or CD-ROM Drive, you may connect the connector of IDE cable to the primary (IDE1) or secondary (IDE2) connector on board, and then connect the gray connector to your slave device and the black connector to your master device. If you install two hard disks, you must configure the second drive to Slave mode by setting its jumpers correctly. Please refer to your hard disk documentation for the jumper settings.

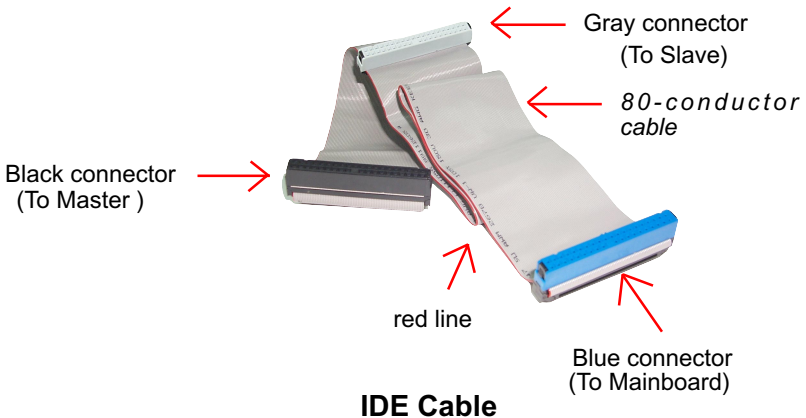
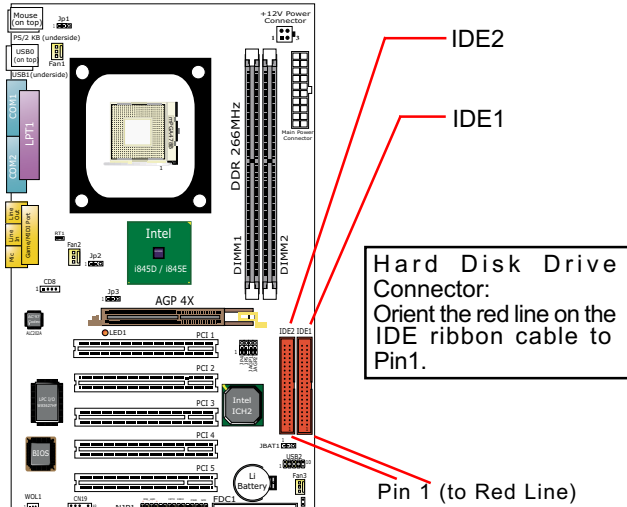

2-6 FDC (Floppy Drive Connector) Installation

To install FDD (Floppy Disk Drive) to FDC, you should connect the end of cable with single connector to the board, and connect the other end with two plugs to the floppy drives.

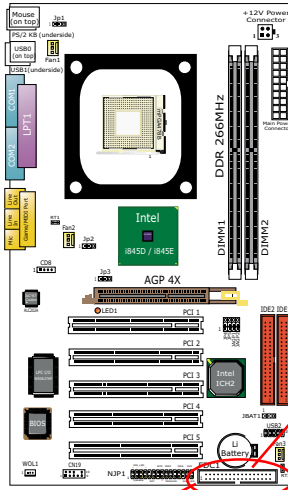

Pin 1 (to Red Line)

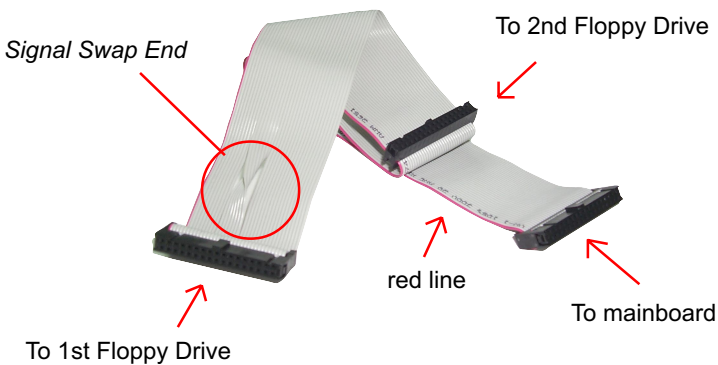

FDD Cable

2-7 ATX V 2.03 Power Supply Installation

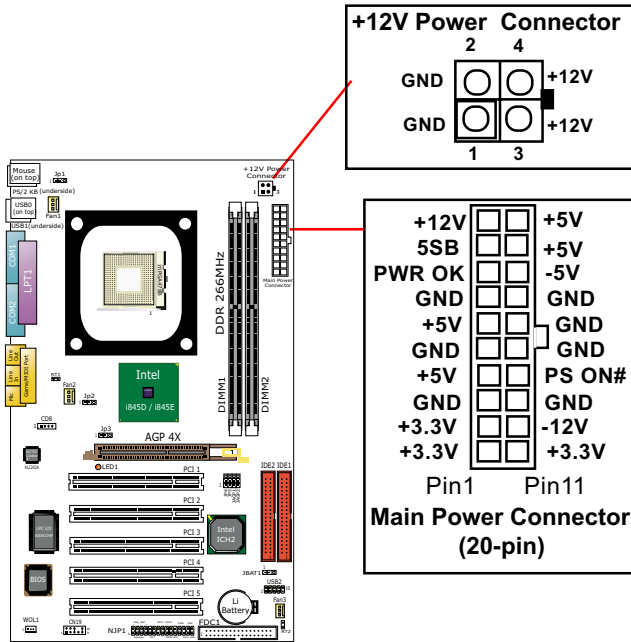



ATX V2.03 power supply is strongly recommended for mainboard running with 2GHz or higher CPU.



To set up Power Supply on this mainboard:

1. Get ready a V2.03 ATX Power Supply which provides a square-shaped +12V Power Connector in addition to the 20-pin Main Power Connector and other peripheral power connectors.
2. Connect the on-board square-shaped +12V Power Connector to the square-shaped +12V Power Connector of the Power Supply.
3. Connect the on-board 20-pin Main Power Connector to the 20-pin Main Power Connector of the Power Supply. Please note that both the +12V Power Connector and the 20-pin Main Power Connector should be connected to Power Supply to power on system.







2-8 Jumper Settings

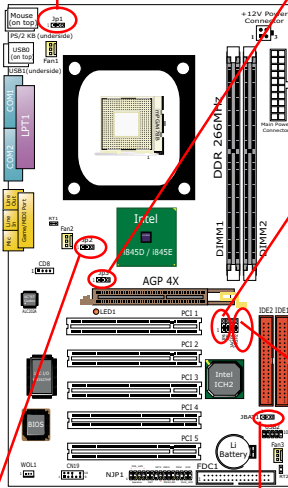





The following diagrams show the locations and settings of jumper blocks on the mainboard.



Jp1: PS/2 KB/Mouse Power On	
1 	1-2 closed (default) PS/2 KB/Mouse Power On Disabled
1 	2-3 closed PS/2 KB/Mouse Power On Enabled



Jp3: AGP4X Safeguard	
1 	(default) Safeguard enabled 1-2 closed for 1.5V AGP 4X only; (Warning: 3.3V AGP 2X can not boot system)
1 	Safeguard disabled 2-3 closed for PCI VGA to boot system; (Warning: 3.3V AGP card will cause 1.5V circuitry burn)



JP4 & JP5:(optional) DIMM Voltage Select		
DIMM Voltage	JP4	JP5
2.5V (default)	1 	1 
2.6V	1 	1 
2.7V	1 	1 

JAGP1&JAGP2:(optional) AGP Voltage Select		
AGP Voltage	JAGP1	JAGP2
1.5V (default)	1 	1 
1.6V	1 	1 
1.7V	1 	1 

Jp2: Front Side Bus Select	
1 	(default) Auto-detect of 533MHz / 400MHz
1 	2-3 closed 533MHz FSB Select

JBAT1: Clear CMOS	
1 	1-2 closed (default) To hold data
1 	2-3 closed To clear CMOS

2-8.1 How to tackle the Jumpers:

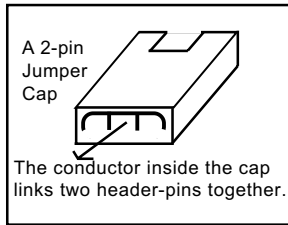
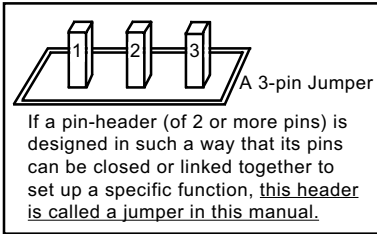

- A Jumper is usually but not necessarily given a “JpX” legend.
- In the Jumper setting diagram, all jumper pins covered with black marks stand for closed pins with jumper cap.



- Do not remove any jumper cap when power is on. Always make sure the power is off before changing any jumper settings. Otherwise, mainboard could be damaged.

2-8.2 Jp2: FSB (Front Side Bus) Select

Jp2 is designed on board as a jumper for system Front Side Bus select.

1. Before selecting the CPU clock, read the Identification Legend on the CPU, find the default (Max) FSB which can be provided by the CPU. If this FSB is divided by 4, the result is the default CPU clock.
2. If Jp2 is set to 1-2 closed, CPU will auto-detect its own (default) CPU clock and run with the default FSB.
3. If Jp2 is set to 2-3 closed, CPU is set to 133MHz and tries to run with 533MHz FSB.
4. If Jp2 2-3 closed cannot boot the system, it means overclocking fails. Please restore Jp2 to 1-2 closed (default) and then clear CMOS with the Clear-CMOS Jumper before trying to reboot system. (See Further Notes on Overclocking.)

Jp2: Front Side Bus Select	
1	(default) 1-2 closed Auto-detect of 533MHz / 400MHz
1	 2-3 closed 533MHz FSB Select

Further Notes on CPU Overclocking:

1. If you have successfully booted system, with or without CPU overclock, you still can try another CPU overclock in BIOS Setup. Please enter BIOS Setup, choose "Frequency/Voltage Control" menu, then configure the "CPU Clock" item to raise your CPU clock.
2. CPU overclocking should take all components on board into account. If you fail in BIOS overclocking, you will not be able to restart system. In such case, Power off system and clear CMOS by JBAT1 and then restart your system. And remember to reconfigure whatever should be reconfigured.
3. If your system is already fixed in a cabinet or case, you may not like to take the trouble to clear CMOS. Then power on your system with the power button on the PC case and simultaneously press down the "Insert" key on the keyboard until you see the initial bootup screen appear. And remember you should also enter CMOS BIOS Setup instantly and choose "Load Optimized Defaults" to restore default BIOS .

2-8.3 JBAT1 : Clear CMOS

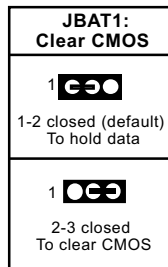

When you have problem with rebooting your system, you can clear CMOS data and restore it to default value. To clear CMOS with Jumper JBAT1, please follow the steps below:

1. Power off system.
2. Set JBAT1 to Pin 2-3 closed.
3. After 2 or 3 seconds, return the JBAT1 setting to Pin1-2 closed.
4. CMOS data are restored to default. Remember never clear CMOS when system power is on.



2-8.4 JP3: AGP 4X Safeguard







1. The AGP slot on board supports 1.5V AGP 4X card only. Any 3.3V AGP 2X card will burn the 1.5V circuitry. Jp3 is designed on board to safeguard the AGP slot against the 3.3V AGP 2X card.
2. Default setting of Jp3 1-2 closed is to enable the safeguard, allowing 1.5V AGP 4X card to boot system only. In this case, if system cannot boot with an AGP card inserted in AGP slot, it indicates that the AGP card is not one of 1.5V type.
3. Setting Jp3 2-3 closed will disable the safeguard, allowing a PCI VGA card to boot system.

Jp3: AGP4X Safeguard	
1 	(default) Safeguard enabled
1-2 closed for 1.5V AGP 4X only; (Warning: 3.3V AGP 2X can not boot system)	
1 	Safeguard disabled
2-3 closed for PCI VGA to boot system; (Warning: 3.3V AGP card will cause 1.5V circuitry burn)	

Warning: If a 3.3V AGP 2X card is now mistakenly inserted for booting the system, the high voltage will burn the 1.5V circuitry on board. Never use a 3.3V or an unknow AGP card on this mainboard.







2-8.5 JP4 & JP5: DIMM Voltage Select (optional)

This function allows users to select the voltage supplied to the SDRAM. The default voltage (2.5V) should be used unless a higher SDRAM voltage is required for matching CPU overclocking on board.

JP4 & JP5:(optional) DIMM Voltage Select		
DIMM Voltage	JP4	JP5
2.5V (default)	1 	1 
2.6V	1 	1 
2.7V	1 	1 



2-8.6 JAGP1 & JAGP2: AGP Voltage Select (optional)

The default voltage 1.5V at AGP slot is for normal operation of the supported AGP 4X. In some case, when you try to do CPU overclocking, a higher AGP voltage is required to match the higher CPU clock. JAGP1 & JAGP2 are designed to provide settings for selecting a higher AGP voltage.

JAGP1&JAGP2:(optional) AGP Voltage Select		
AGP Voltage	JAGP1	JAGP2
1.5V (default)	1 	1 
1.6V	1 	1 
1.7V	1 	1 

2-8.7 Jp1: PS/2 KB/Mouse Power On

Jp1 is designed to enable / disable PS/2 Keyboard/Mouse Power on function. Setting Jp1 to 1-2 closed will disable this function. Setting Jp1 to 2-3 closed will enable this function. Yet user still has to enter BIOS Setup for choosing the KB/ Mouse Power-on mode. (See Integrated Peripherals” in BIOS Setup.)

Jp1: PS/2 KB/Mouse Power On	
 1	1-2 closed (default) PS/2 KB/Mouse Power On Disabled
 1	2-3 closed PS/2 KB/Mouse Power On Enabled

2-9 Other Connectors Configuration

This section lists out all connectors configurations for users' reference.

2-9.1 On Board Fan Connectors

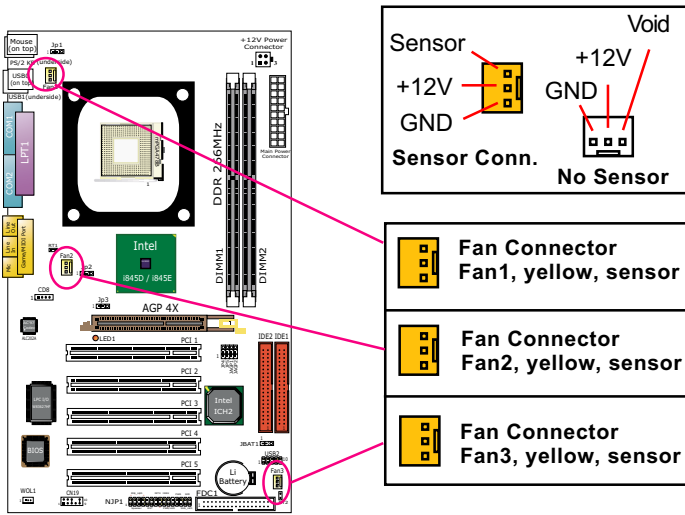

Both Sensor and No-sensor Fan Connectors support CPU/AGP/System/Case cooling fan with +12V mode. When connecting the wire to any Fan Connector, users should make sure that the red wire is for the positive current and should be connected to pin +12V, and the black wire is Ground and should be connected to pin GND.

A Hardware Monitor chipset is on board, with which users can install a Hardware Monitor Utility and read the fan speed transmitted from the sensor fan. Otherwise, users can read the fan speed from the “Hardware Monitor Status” in CMOS BIOS.

A running Fan will send out 2 electric pulses per rotation of its fan blade. A Sensor Fan Connector will count the electric pulses and send the information to the System Hardware Monitor which in turn will work out the fan rotation speed and display it on screen.

2-9.2 WOL1: Wake On LAN

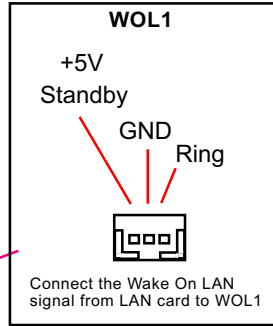
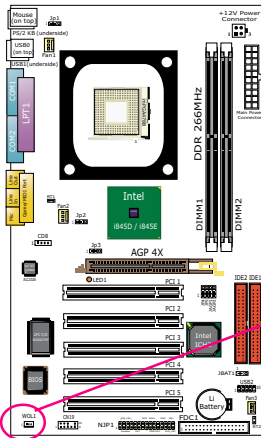

- This connector connects to a LAN card with a Wake On Ring output. The connector powers up the system when it receives a wake-up packet or signal through the LAN card.
- This feature requires that Resume On Lan feature is enabled in the BIOS setting “Power Management Setup” and that your system must be on ATX power supply with at least 720mA / +5V standby power.

2-9.3 CD-ROM Audio Connector CD8

CD8 is an audio connector connecting CD-ROM audio to mainboard.

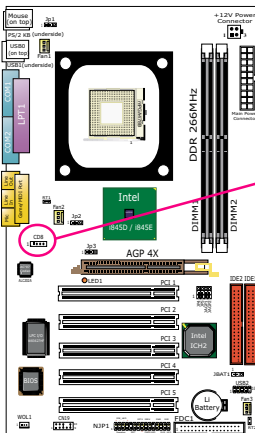

CD-ROM Audio Connector	
CD8 	Pin Signal
Pin 1	Left Channel
Pin 2	GND
Pin 3	GND
Pin 4	Right Channel

2-9.4 RT1 & RT2: Thermal Resistor and Connector

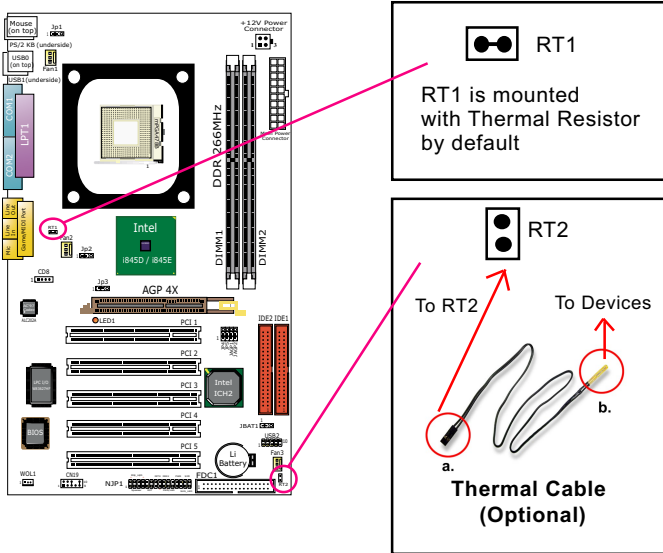

1. Resistor RT1: A thermal resistor is already soldered to connector RT1 so as to detect the temperature round the mainboard. What RT1 does is to transmit the thermal signal to BIOS or Hardware Monitor.

2. Connector RT2: A thermal cable is needed to connect RT2 to on-board devices such as HDD, Graphics card etc., so as to detect the temperature generated therein. Please connect the end (a) of the thermal cable to mainboard RT2 header, and tape another end (b) of thermal cable on to the device which you want to monitor. After you have finished the thermal cable installation, you will **see the detected temperature in BIOS setup or Hardware monitor utility.**

2-9.5 Complex Header

- This complex Header consists of 10 connectors providing various supports:

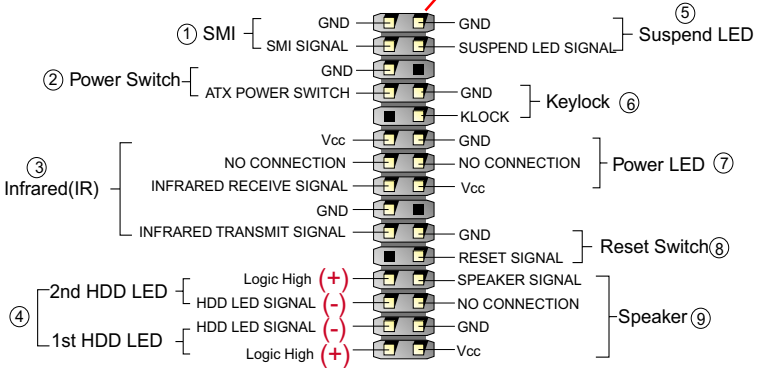
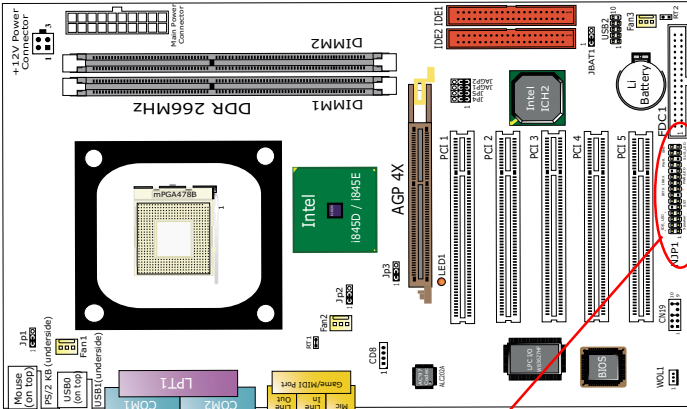

(1) SMI Connector (Optional):

Connection: Connected to the Suspend Switch.

Function: Manually selecting DOS system into the Suspend Mode or “Green Mode” by System Mangement Interrupt.

(2) Power Switch Connector:

Connection: Connected to a momentary button or switch.

Function: Manually switching the system between “On” and “Soft Off”. Pressing the momentary button for more than 4 seconds will also turn the system off.

(3) IR Connector (Infrared Connector):

Connection: Connected to Connector IR on board.

Function: To support wireless transmitting and receiving module on board.

(4) 1st HDD LED Connector/2nd HDD LED Connector:

Connection: Connected to HDD LED.

Function: To supply power to HDD LED.

(5) Suspend LED Connector:

Connection: Connected to Suspend Indicator.

Function: To supply power to “Suspend Indicator”.

(6) Keylock Connector (Optional):

Connection: Connected to keyboard.

Function: To lock keyboard and disable keyboard function.

(7) Power LED Connector:

Connection: Connected to System Power LED.

Function: To supply power to “System Power LED”.

(8) Reset Switch Connector:

Connection: Connected to “Reset Switch”.

Function: To supply power to “Reset Switch” and support system reboot function.

(9) Speaker Connector:

Connection: Connected to the case-mounted Speaker.

Function: To supply power to the case-mounted Speaker.

2-9.6 USB Ports and USB Header

This series provides two USB ports USB0 and USB1 on board. In addition, USB2 is an additional USB header to support two additional USB ports by using a USB Cable. User can order the additional USB cable from your mainboard dealers or vendors.

When plugging the USB cable into USB Header, you must make sure the red wire is connected to Pin 1.

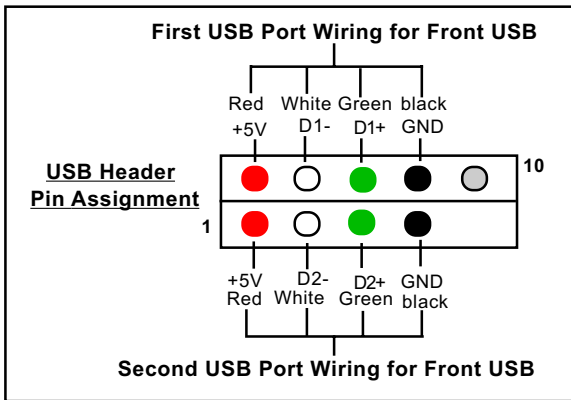
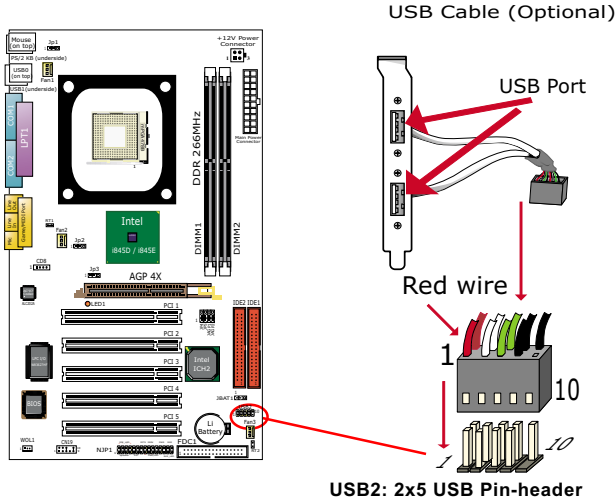

2-9.7 Chassis Panel Connector

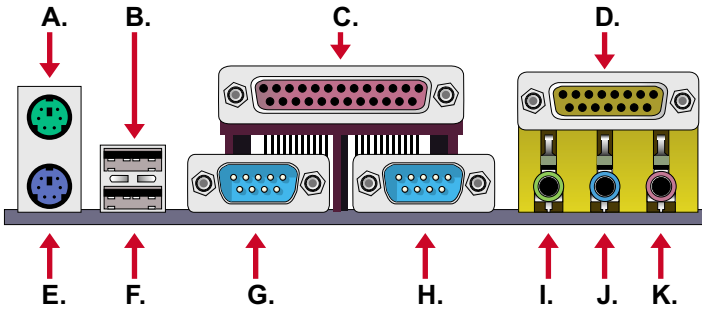

- | | |
|------------------------|----------------------|
| A : PS/2 Mouse Port | G : COM1 Port |
| B : USB 0 Port | H : COM2 Port |
| C : LPT1 Port | I : Line/Speaker Out |
| D : Game/MIDI Port | J : Line In |
| E : PS/2 Keyboard Port | K : Microphone Input |
| F : USB 1 Port | |

2-9.8 PS/2 Mouse and PS/2 Keyboard

PS/2 Mouse Connector (on top, green)

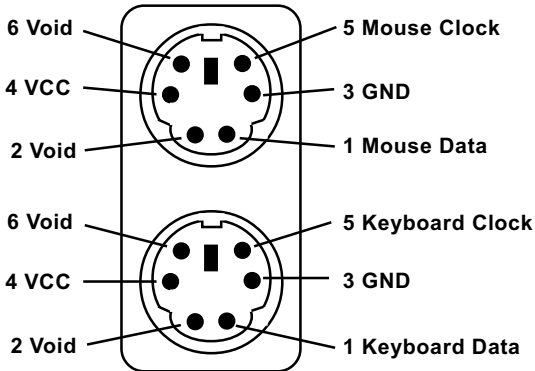

PS/2 Keyboard Connector (underside, purple)

2-9.9 CN19: Front Panel Audio Connector (optional)

This Mainboard is designed with a Front Panel Audio connector “CN19” which provides connection to the Front Panel Audio.

1. When CN19 is set to 5-6 closed and 9-10 closed, this default setting disables this connector and leaves the Back Panel Audio enabled.
2. To use this Front Panel Audio Connector, please open all pins of CN19 and connect it to your chassis.

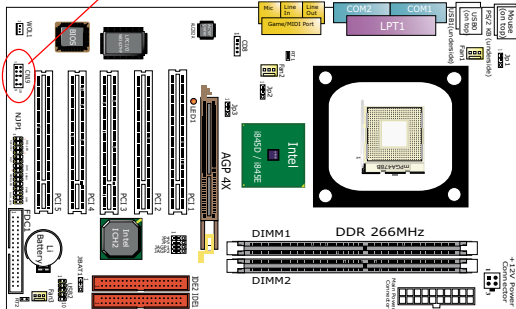
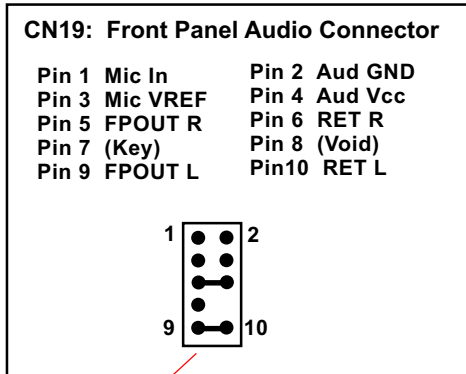

Chapter 3 Software Setup

Drivers, Utilities and Software Installation

- Support CD:

This mainboard will be shipped with a Support CD which contains those necessary driver files, Application Softwares and some helpful utilities. It is a user-friendly, auto-run CD which will open itself up in a CD-ROM automatically.

- Contents and Installation of Support CD:

This chapter is devoted to describing the installations of all these essential drivers and utilities on Windows 9X, Windows ME, Windows 2000 and Windows XP. The installation procedures for all these operating systems are all programmed into an auto-run mode. What users have to do is to read and follow the pop-up instructions to carry out the installation. We therefore take the installation on Windows 98 as the general illustration hereby.

The priority of drivers to be installed should also be noted. Users are recommended to take the following installation orders :

3-1 Open up the Support CD

3-2 Intel Chipset Software Installation Utility (INF Utility)

3-3 Intel Application Accelerator (IAA)

3-4 AC'97 Audio Drivers Installation

3-5 Hardware Monitor Utility

3-1 Open up the Support CD

1 Please put the Support CD enclosed in your mainboard package into the CD-ROM drive. In a few seconds, the Main Menu will automatically appear, displaying the contents to be installed for this series:

Intel Chipset Software Installation Utility (INF Utility)

Intel Application Accelerator (IAA)

AC'97 Drivers Installation

Hardware Monitor Utility

Install Acrobat Reader

Browse CD-ROM

Exit

2 In case your system does not open the Support CD automatically, please click to the following path to enter the Main Installation Menu:

D:\Autorun.exe (assuming that your CD-ROM Drive is Drive D)

3-2 To Install “Intel Chipset Software Installation Utility”

1 Following the procedures of opening the Support CD, click to “Install Intel Chipset software installation Utility” to proceed.

2 The Intel Service Pack InstallShield Wizard will pop up to guide you to the Intel Service pack installation. Press **“Next”** button to continue.

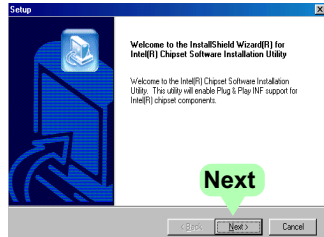

3 “Intel Software License Agreement” screen will appear, please click the **“Yes”** button to agree with the Licence Agreement and continue.

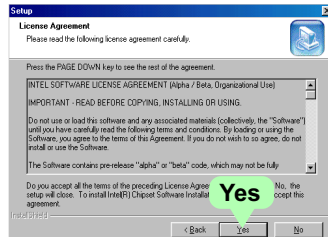

4 After all the setup process is finished, please restart your computer by clicking on **“Finish”** so as to take the Utility into effect.

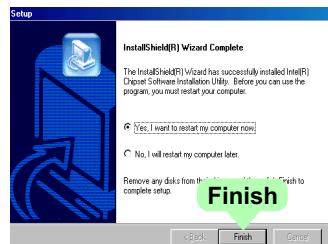

3-3 To Install “Intel Application Accelerator”

IAA supports all Windows 98/98se/Millennium/NT4/2000/XP with Pentium III / 4 processor. Installations of this software for these operating systems are similarly programmed to an auto-run mode, and it is typically designed to improve performance of the storage sub-system and overall system performance.

Below is a model installation on Windows 98. Users of Windows Me/NT4/2000/XP can also follow this example for IAA installation.

1 Following the procedures of opening the Support CD, click to “Intel Application Accelerator” to proceed.

2 On the “InstallShield Wizard” screen, Click on “Next” to continue.

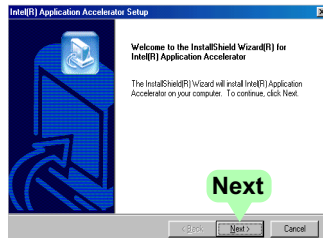

3 On the “Licence Agreement” screen, click on “Yes” to continue.

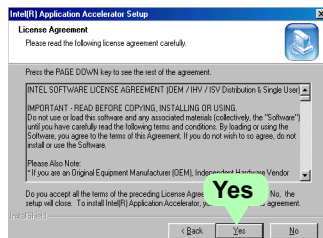

4 On "Choose Destination Location" screen, press "Next" to continue.

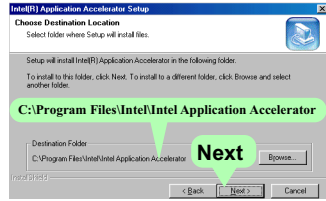

5 On "InstallShield Wizard Complete" screen, choose "Yes, I want to restart my computer now" and press "finish" to restart. Remember you must restart computer to put setup into effect.

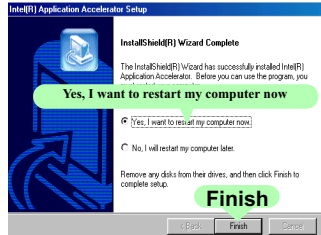

3-4 To Install AC'97 Audio Driver

You can install “AC'97 Audio Driver” on these two members of the series.

1 Following the procedures of opening the Support CD, click to “AC'97 Audio Driver” to proceed.

2 When the “**Avance AC'97 Drivers and Applications**” screen appears, press “**Next**” to continue.

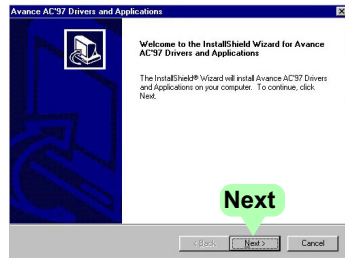

3 After all the setup process is finished, please click the “**Yes, I want to restart my computer now.**” and click “**Finish**” to restart your system.



3-5 To Install Hardware Monitor Utility

3-5.1 Installation

Hardware Monitor is built on this mainboard. Its installation is programmed to a fully automated mode on Windows 9X/Me/NT4/2000/XP. User can follow the model installation below for its installation on various Windows System.

1 Following the procedures of opening the Support CD, click to “Hardware Monitor Utility” to proceed.

2 With the help of InstallShield Wizard, installation program automatically opens the “Choose Destination Location” screen. Click “Next” to continue.

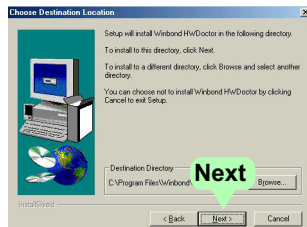

3 Select the Program folder and click “Next” to continue.



4 On the “Setup complete” screen, click “Finish” to restart your computer so that the Utility can be put into effect.

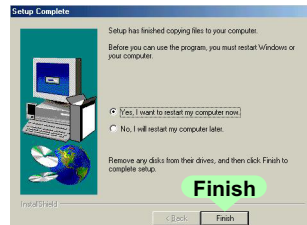

3-5.2 Verification

1 After restarting your computer, click “Start” and choose the path Programs \WinbondHwdoctor to open the main window of the Hardware Doctor.

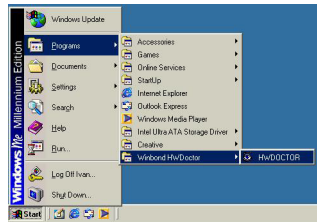

2 The “Voltage/CaseOpen” window is for CPU voltage and temperature information.

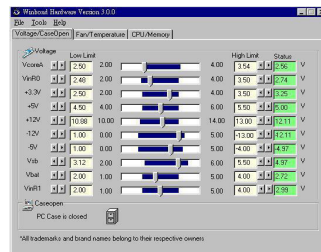

3 The “Fan/Temperature” window is for Fan speed and temperature information.

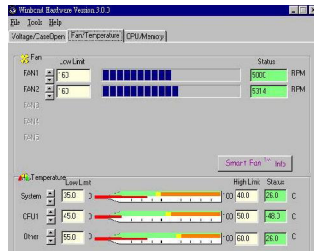

4 The “CPU/Memory” window is for Processor and memory information.

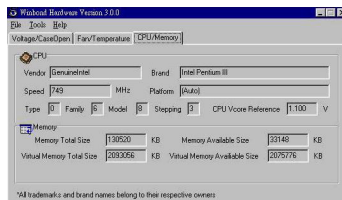

Chapter 4 AMI BIOS Setup

THE BIOS

BIOS stands for Basic Input and Output System. It was once called ROM BIOS when it was stored in a Read-Only Memory (ROM) chip. Now manufacturers would like to store BIOS in EEPROM which means Electrically Erasable Programmable Memory. BIOS used in this mainboard is stored in EEPROM, and is the first program to run when you turn on your computer.

BIOS performs the following functions:

1. Initializing and testing hardware in your computer (a process called "POST", for Power On Self Test).
2. Loading and running your operating system.
3. Helping your operating system and application programs manage your PC hardware by means of a set of routines called BIOS Run-Time Service.

This Chapter includes the following topics :

4-1 About BIOS Setup

4-2 To run BIOS Setup

4-3 About CMOS

4-4 The POST (Power On Self Test)

4-5 To upgrade BIOS

4-6 BIOS Setup

4-1 About BIOS Setup

BIOS setup is an interactive BIOS program that you need to run when:

1. Changing the hardware of your system. (For example: installing a new Hard Disk etc.)
2. Modifying the behavior of your computer. (For example: changing the system time or date, or turning special features on or off etc.)
3. Enhancing your computer's behavior. (For example: speeding up performance by turning on shadowing or cache)

4-2 To Run BIOS Setup

First access BIOS setup menu by pressing < DEL > key after "POST" is complete (before OS is loaded). BIOS will then display the following message:

```
DEL: SETUP
```

4-3 About CMOS

CMOS is the memory maintained by a battery. CMOS is used to store the BIOS settings you have selected in BIOS Setup. CMOS also maintains the internal clock. Every time you turn on your computer, the BIOS Looks into CMOS for the settings you have selected and configures your computer accordingly. If the battery runs out of power, the CMOS data will be lost and POST will issue a "CMOS invalid" or "CMOS checksum invalid" message. If this happens, you have to replace the battery and check and configure the BIOS Setup for the new start.

4-4 The POST (Power On Self Test)

POST is an acronym for Power On Self Test. This program will test all things the BIOS does before the operating system is started. Each of POST routines is assigned a POST code, a unique number which is sent to I/O port 080h before the routine is executed.

4-5 To Update BIOS

- System BIOS is incorporated into a Flash memory component. Flash BIOS allows user to upgrade BIOS without the need to replace an EPROM component.
- The Upgrade Utility can be loaded on a floppy diskette for upgrading saving, and verifying the system BIOS. The Upgrade Utility can also be run from a hard disk drive or a network drive.

4-5.1 Before Update BIOS

- It is highly recommended that you save a copy of the original mainboard BIOS along with a Flash EPROM Programming utility (AMIFLASH.EXE) to a bootable floppy disk so that you can reinstall the BIOS when in need.

4-5.2 Update Process

- Normally, to update BIOS is unnecessary if the system is working fine. Users should only upgrade BIOS when incompatible problems are encountered or new features have to be added to system.
- “AMIFLASH.EXE” is a Flash EPROM Programming utility that updates the BIOS by uploading a new BIOS file to the programmable flash ROM on the mainboard. This program only works in ***DOS environment, the utility can not be executed in Win95/98, ME, NT, WINDOWS 2000 or Windows XP environment.***
- Please follow the steps below for updating the system BIOS:

Step 1. Please visit the board maker’s website, download latest BIOS file and AMI flash utility “AMIFLASH.EXE”. The BIOS file format will be *.ROM, of which “*” stands for the specific BIOS file name.

Step 2. Create a bootable diskette. Then copy the BIOS file and AMI flash utility “AMIFLASH.EXE” into the diskette.

Step 3. Insert the diskette into drive A, reboot your system and boot from the diskette.

Step 4. Type **AMIFLASH *.ROM** and then press <Enter> to run BIOS update program. (*.ROM will vary, depending on your mainboard model and version code. Instead of typing “*”, you should type specific file name for your specific mainboard. For example: AMIFLASH(space) 75FRV11.ROM)

Step 5. When the message “Flash ROM Update Completed - Pass.” appears, please restart your system.

Step 6. You will see a message “CMOS Memory Size Wrong” during booting the system. Press or <F1> to run CMOS setup utility, then reload “LOAD SETUP DEFAULTS” or “**Load Optimal Defaults**” and save this change. BIOS update is complete now.

4-6 BIOS SETUP --- CMOS Setup Utility

4-6.1 CMOS Setup Utility

This mainboard comes with the AMI BIOS from American Megatrends Inc. Enter the CMOS Setup Utility Main Menu by:

1. Turn on or reboot your system. After a series of diagnostic checks, the following message will appear:

PRESS TO RUN SETUP

2. Press the key and the main program screen will appear as follows.

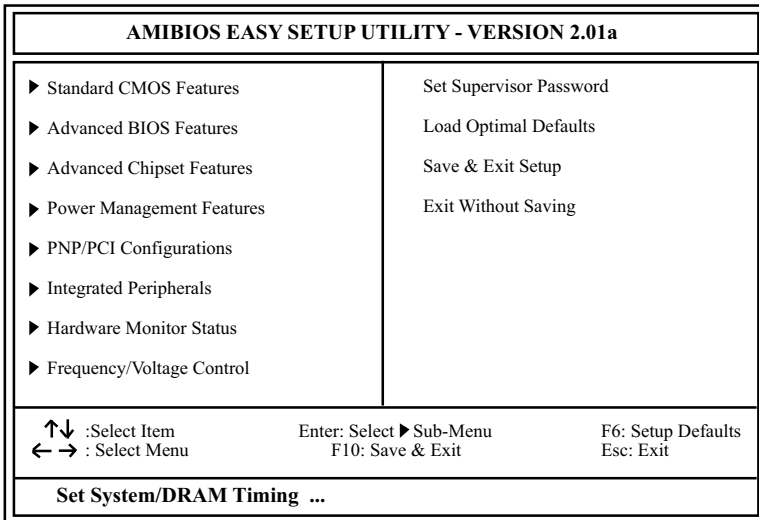

3. Use the arrow keys on your keyboard to select an option, and press <Enter>. Modify the system parameters to reflect the options installed in your system.
4. You may return to the Main Menu anytime by pressing <ESC>.
5. In the Main Menu, "Save & Exit Setup" saves your changes and reboots the system, and "Exit Without Saving" ignores your changes and exits the program.

4-6.2 Standard CMOS Setup

Standard CMOS Setup records some basic system hardware configuration and sets the system clock and error handling. You only need to modify the configuration values of this option if you want to change your system hardware configuration or when the data stored in the CMOS memory is lost or damaged.

Run the Standard CMOS Setup as follows:

1. Choose "Standard CMOS Setup" from the Main Menu and a screen with a list of options will appear:

Standard CMOS Features		Setup Help
System Time	00 19 29	
System Date	Mar 04 2003 Tue	
Floppy Drive A	1.44 MB, 3.5 in.	
▶ Primary IDE Master	Maxtor 20560 A4	
▶ Primary Slave	Not Installed	
▶ Secondary Master	Not installed	
▶ Secondary Slave	Not Installed	

↑↓ : Select Item
Esc: Previous Menu

+/- : Change Values
Enter: Select ▶ Sub-Menu

F6: Setup Defaults
F10: Save & Exit

2. Use one of the arrow keys to move between options and modify the selected options by using PgUp / PgDn / + / - keys.
3. Press <ESC> to return to the Main Menu when you finish setting up all items. The following item descriptions are provided as a quick guide to your setup.

System Time The BIOS shows the time of the day in the format: hh:mm:ss. Choose the field with the Arrow keys and change the time with the Page Up/Page Down +/- keys.

System Date The BIOS shows the date of the day in the format: mm:dd:yy :day of the Week. Choose the field with the Arrow keys and change the value with the Page Up/Page Down +/- keys.

Floppy Drive A Select this field to the type(s) of floppy disk drive(s) installed in your system. The choices are:
 1.2MB, 5.25 in.
 720KB, 3.5 in.
 1.44MB, 3.5 in.
 2.88MB, 3.5 in.
 Not Installed

Primary/Secondary IDE Master/Slave Press Enter on any one of these four items will reveal the following submenu for your configuration of the hard Disk you have installed:

Primary IDE Master :Maxtor 82560 A4		Setup Help
Type	Auto	
Cylinders	4962	
Heads	16	
Write Precompensation		
Sectors	63	
Maximum Capacity	2561 Mb	
LBA Mode	On	
Block Mode	On	
Fast Programmed I/O Modes	4	
32 Bit Transfer Mode	On	

↑↓ : Select Item
 Esc: Previous Menu

+/- : Change Values
 Enter: Select ► Sub-Menu

F6: Setup Defaults
 F10: Save & Exit

Type This option shows the types of configuration for the IDE devices:

1-50: Predefined types

USER: set Parameters by User

Auto: Set Parameters automatically

CD-ROM: Use for ATAPI CD-ROM drives

Double click [Auto] to set all HDD parameters automatically, including “Cylinders, Heads, Write Precompensation, Sectors, Maximum Capacity and 32 Bit Transfer Mode.

4-6.3 Advanced BIOS Features

Advanced BIOS Features improves your system performance or sets up system features according to your preference.

Run the Advanced BIOS Features as follows:

1. Choose “Advanced BIOS Features” from the Main Menu and a screen with a list of options will appear:

AMIBIOS EASY SETUP UTILITY - VERSION 2.01a

Advanced BIOS Features	Setup Help
Quick Boot	Enabled
Delay for Hard Drive (Sec.)	2
1st Boot Device	Floppy: 1.44 MB 3.5
2nd Boot Device	CD-ROM
3rd Boot Device	IDE-0 :Maxtor 20560
Try Other Boot Devices	Yes
Initial Display Mode	Silent
Display Mode at Add-On ROM Init	Force BIOS
S.M.A.R.T for Hard Disks	Disabled
Bootup Num-lock	On
Floppy Drive Swap	Disabled
Floppy Drive Seek	Disabled
Primary Display	VGA/EGA
Password Check	Setup
Boot To OS/2	No
L1 Cache	Enabled
L2 Cache	Enabled
System BIOS Cacheable	Enabled
C000,32K Shadow	Cached
C800,16K Shadow	Disabled
CC00,16K Shadow	Disabled
D000,16K Shadow	Disabled
D400,16K Shadow	Disabled
D800,16K Shadow	Disabled
DC00,16K Shadow	Disabled

↑↓ : Select Item
Esc: Previous Menu

+/- : Change Values
Enter: Select ▶ Sub-Menu

F6: Setup Defaults
F10: Save & Exit

2. Use one of the arrow keys to move between options and modify the selected options by using PgUp / PgDn / + / - keys. An explanation of the <F> keys follows:

<F1>: "Help" gives options available for each item.

<F6>: Setup BIOS default values.

<F10>: Save and Exit Setup.

3. Press <ESC> to return to the Main Menu when you finish setting up all items. The following item descriptions are provided as a quick guide.

-
- Quick Boot** Allows you to enable / disable quick boot of your system.
- Delay for Hard Drive (Sec.)** Allows you to set the delay time for hard drive access.
Choices: Disabled; 1~10 sec. (Default: 2)
- 1st/2nd/3rd Boot Device** Allows you to set floppy or IDE devices already installed to be the 1st/2nd/3rd boot device.
Choices: Disabled; Device(s) installed
- Try Other Boot Devices** Allows you to enable/disable system to try to boot with other boot devices.
Choices: Yes; No
- Initial Display Mode** This item allows user to choose the initial display screen at bootup. If "Silent" is chosen, the initial display will be the vendor's logo screen. If "BIOS" is chosen, the initial display will be the normal "POST" display.
- Display Mode at Add-On ROM Init** If the item "Initial Display Mode" is set to "Silent", two sub-modes are provided for the initial display mode. If "Force BIOS" is chosen, the vendor's logo screen will be followed by the "Add-on ROM" initial screen (the screen showing the add-on card BIOS message). If "Keep Current" is chosen, no "Add-On ROM" screen is followed.

- S.M.A.R.T. for Hard Disks** Allows you to enable / disable the Self Monitoring Analysis and Reporting Technology for the hard disk.
Choices: Enabled; Disabled
- BootUp Num-Lock** Allows you to Toggle between On or Off to control the state of the NumLock key when the system boots. If On, the numeric keypad is in numeric mode. If off, the numeric keypad is in cursor control mode.
- Floppy Drive Swap** Choices: Disabled (default); Enabled
- Floppy Drive Seek** Choices: Disabled (default); Enabled
- Primary Display** Allows you to choose the primary display for the system.
Choices: VGA/EGA (default); CGA40x25; CGA80x25; Mono; Absent
- Password Check** Allows you to set BIOS to check up password with a password prompt at BIOS Setup or whenever re-starting system.
Choices: Setup; Always
- Boot to OS/2** Allows you to set your system to OS/2 operating system.
Choices: Yes; No (default)
- L1 /L2 Cache** Allows you to set the Internal/External Cache Mode.
Choices: WriteBack (default); WriteThru; Disabled
- System BIOS Cacheable** Allows you to enable / disable the System BIOS Cacheable function.
- C000, 32K Shadow** Allows you to set these addresses cached, Enabled or Disabled. (Default): Cached
- C800,CC00,D000,D400, D800,DC00 16K Shadow** Allows you to set these addresses cached, Enabled or Disabled. (Default): Disabled

4-6.4 Advanced Chipset Features

Advanced Chipset Features is used to modify the values of chipset buffers. These buffers control the system options.

Run the Advanced Chipset Features as follows:

1. Choose "Advanced Chipset Features" from the Main Menu and a list of option will appear:

AMIBIOS EASY SETUP UTILITY - VERSION 2.01a

Advanced Chipset Features	Setup Help
DRAM Timing	
SDRAM Frequency	Auto
Configure SDRAM timing by SPD	Disabled
SDRAM CAS# Latency	2.5 Clocks
SDRAM RAS# Precharge	3 Clocks
SDRAM RAS# to CAS# Delay	3 Clocks
SDRAM Precharge Delay	7 Clocks
SDRAM Read Thermal Management	Disabled
DRAM Integrity Mode	Disabled
Memory Hole	Disabled
(Hyper-threading Function)	(Enabled)
AGP Aperture Size	64MB
USB Controller	All USB Port
USB Device Legacy Support	Disabled
Port 64/60 Emulation	Disabled

↑↓ : Select Item
Esc: Previous Menu

+/- : Change Values
Enter: Select ► Sub-Menu

F6: Setup Defaults
F10: Save & Exit

2. Use one of the arrow keys to move between options and modify the selected options by using PgUp / PgDn / + / - keys. An explanation of the <F> keys follows:

<F1>: "Help" gives options available for each item.

<F6>: Setup BIOS default values.

<F10>: Save and Exit Setup.

3. Press <ESC> to return to the Main Menu when you finish setting up all items. The following item descriptions are provided as a quick guide to your setup.

- SDRAM Frequency** Allows you to set the SDRAM frequency.
Choices for 100MHz CPU: Auto; 200MHz; 266MHz
Choices for 133MHz CPU: Auto; 200MHz;266MHz
- Configure SDRAM Timing by SPD** Choices: Enabled; disabled (default)
- SDRAM CAS# Latency** With SDRAM Timing by SPD disabled, you can select the SDRAM CAS# (Column Address Strode) latency.
Choices: 2 Clocks; 2.5 Clocks
- SDRAM RAS# Precharge** With SDRAM Timing by SPD disabled, you can select the SDRAM RAS# (Row Address Strode) Precharge cycle.
Choices: 2 Clocks; 3 Clocks
- SDRAM RAS# to CAS# Delay** With SDRAM Timing by SPD disabled, you can select the SDRAM RAS# to CAS# delay cycle.
Choices: 2 Clocks; 3 Clocks
- SDRAM Precharge Delay** With SDRAM Timing by SPD disabled, you can select the SDRAM Precharge Delay cycle.
Choices: 7 Clocks; 6 Clocks; 5 Clocks
- SDRAM Read Thermal management** Allows you to enable / disable the function.
Choices: Enabled; Disabled
- DRAM Integrity Mode** Allows you to enabled / disabled (default) this function.
Choices: Disabled; ECC
- Memory Hole** Allows you to enabled / disabled (default) the memory (15~16MB) reserved for the peripherals.
- (Hyper-Threading Function)** If hyper-threading CPU is running on board, this item appears to show the enabled status.
Choices: Enabled; Disabled

AGP Aperture Size Allows you to set the AGP Aperture Size.
Choices: 4MB; 8MB; 16MB; 32MB; 64MB; 128MB;
256MB;

USB Controller Allows you to set the USB Controller on the USB
port(s).
Choices: All USB; USB Port 0&1;
USB Port 2&3; Disabled

USB Device Legacy Support Allows you to select the USB Device Legacy support.
Choices: No Mice; All Device; Disabled

Port 64/60 Emulation Allows you to enable / disable (default) the Port 64/
60 Emulation.

4-6.5 Power Management Features

Power Management Features allows you to set the system's power saving functions.

Run the Power Management Features as follows:

1. Choose "Power Management Features" from the Main Menu and a list of options will appear:

AMIBIOS EASY SETUP UTILITY - VERSION 2.01a

Power Management Features	Setup Help
ACPI Standby State	S1/POS
Power Management/APM	Enabled
Video Power Down Mode	Suspend
Hard Disk Power Down Mode	Stand By
Standby Time Out (Minute)	Disabled
Suspend Time Out (Minute)	Disabled
Power Button Function	On/Off
Restore on AC/Power Loss	Last State
Resume On Ring	Disabled
Resume On LAN/PME	Disabled
Resume On RTC Alarm	Disabled
RTC Alarm Date	15
RTC Alarm Hour	12
RTC Alarm Minute	30
RTC Alarm Second	30

↑↓ : Select Item
Esc: Previous Menu

+/- : Change Values
Enter: Select ►Sub-Menu

F6: Setup Defaults
F10: Save & Exit

2. Use one of the arrow keys to move between options and modify the selected options by using PgUp / PgDn / + / - keys. An explanation of the <F> keys follows:

<F1>: "Help" gives options available for each item.

<F6>: Setup BIOS default values.

<F10>: Save and Exit Setup.

3. Press <ESC> to return to the Main Menu when you finish setting up all items. The following item descriptions are provided as a quick guide to your setup.

- ACPI Standby State** This item allows you to see the supported ACPI Standby state S1 (POS) for Power on Suspend under Windows 98 ACPI mode. This Mainboard does not support S3 (STR).
- Power Management/ APM** Allows you to enable / disable the Power management / Advanced Power Management function.
- Video Power Down Mode** Allows you to select the Video Power Down Mode. Choices: Disabled; Standby; Suspend
- Hard Disk Power Down Mode** Allows you to select the Hard Disk Power Down Mode. Choices; Disabled; Standby; Suspend
- Standby Time Out (Minute)** To set the duration of Standby Time Out. Choices: 1; 2; 4; 8; 10; 20; 30; 40; 50; 60
- Suspend Time Out (Minute)** To set the duration of Suspend Time Out. Choices: 1; 2; 4; 8; 10; 20; 30; 40; 50; 60
- Power Button Function** allows you to set power Button function. Choices: On/Off; Suspend
- Restore on AC/Power Loss** Allows you to set the restore state from AC/Power Loss. Choices: Last State; Power Off; Power On
- Resume on Ring** Allows you to enable / disable the Resume on Ring Signal function.
An input signal on the serial Ring Indicator (RI) Line (in other words, an incoming call on the modem) Awakens the system from a soft off state.

Resume on LAN/PME Allows you to enable / disable the Resume on LAN /PME function.

Resume On RTC Alarm Allows you to enable / disable the Resume On RTC Alarm function.

RTC Alarm Date / Hour / Minute / Second If resume On RTC Alarm is enabled, this field allows you to set the Alarm date Hour, Minute and second.
Date Choices: Every Day; 01 ~ 31
Hour Choices: 00 ~ 23
Minute Choices: 00 ~ 59
Second Choices: 00 ~ 59

4-6.6 PNP / PCI Configurations

PNP/PCI Configuration allows you to modify the system's power saving functions.

Run the PNP/PCI Configurations as follows:

1. Choose "PNP/PCI Configurations" from the Main Menu and a screen with a list of options will appear:

AMIBIOS EASY SETUP UTILITY - VERSION 2.01a

PNP/PCI Configurations	Setup Help
Plug and Play Aware O/S	No
PCI Latency Timer (PCI Clocks)	32
Primary Graphics Adapter	AGP
PCI IDE Busmaster	Enabled
PCI Slot1 IRQ Priority	Auto
PCI Slot2 IRQ Priority	Auto
PCI Slot3 IRQ Priority	Auto
PCI Slot4 IRQ Priority	Auto
PCI Slot5 IRQ Priority	Auto

↑↓ : Select Item
Esc: Previous Menu

+/- : Change Values
Enter: Select ▶ Sub-Menu

F6: Setup Defaults
F10: Save & Exit

2. Use one of the arrow keys to move between options and modify the selected options by using PgUp / PgDn / + / - keys. An explanation of the <F> keys follows:

<F1>: "Help" gives options available for each item.

<F6>: Setup BIOS default values.

<F10>: Save and Exit Setup.

3. Press <ESC> to return to the Main Menu when you finish setting up all items. The following item descriptions are provided as a quick guide to your setup.

Plug & Play Aware O/S Select Yes for Windows systems supporting Plug and Play function. Select No for systems not supporting PNP.

PCI Latency Timer (PCI Clocks) Allows you to set the PCI Latency Time.
Choices: 32; 64; 96; 128; 160; 192; 224; 248;

Primary Graphics Adapter Allows you to select the Graphics Adapter.
Choices: AGP; PCI

PCI IDE BusMaster Allows you to enable / disable the PCI IDE Bus Master function.

PCI Slot1/2/3/4/5 IRQ Priority Allows you to specify the IRQ for the PCI slot.
Choices: Auto; 3; 4; 5; 7; 9; 10; 11

4-6.7 Integrated Peripherals

Integrated Peripherals option allows you to get some information inside your system when it is working.

Run the Integrated Peripherals as follows:

1. Choose "Integrated Peripherals" from the Main Menu and a list of options will appear:

AMBIOS EASY SETUP UTILITY - VERSION 2.01a

Integrated Peripherals	Setup Help
Onboard IDE	Both
Onboard AC'97 Audio	Auto
Onboard FDC	Auto
Onboard Serial Port A	Auto
Onboard Serial Port B	Auto
Serial Port B Mode	Normal
IR Duplex Mode	Half Duplex
IR Pin Select	IRRX/IRTX
Onboard Parallel Port	Auto
Parallel Port Mode	Normal
EPP Version	N/A
Parallel Port IRQ	Auto
Parallel Port DMA Channel	N/A
Onboard MIDI Port	Disabled
MIDI IRQ Select	5
Onboard Game Port	200
PS/2 Keyboard PowerOn Function	Disabled
Specific Key for PowerOn	N/A
PS/2 Mouse PowerOn Function	Disabled

↑↓ : Select Item
Esc: Previous Menu

+/- : Change Values
Enter: Select ▶ Sub-Menu

F6: Setup Defaults
F10: Save & Exit

2. Use one of the arrow keys to move between options and modify the selected options by using PgUp / PgDn / + / - keys. An explanation of the <F> keys follows:

<F1>: "Help" gives options available for each item.

<F6>: Setup BIOS default values.

<F10>: Save and Exit Setup.

3. Press <ESC> to return to the Main Menu when you finish setting up all items. The following item descriptions are provided as a quick guide to your setup.

- Onboard IDE** Allows you to choose the Onboard IDE Mode.
Choices: Disabled; Primary; Secondary; Both
- Onboard AC'97 Audio** Allows you to enable / disable the Onboard AC'97 Audio.
The choices: Auto; Disabled
- OnBoard FDC** Allows you to enable / disable the Onboard FDC.
Choices: Auto; Enabled; disabled
- Onboard Serial Port A** Allows you to set the Onboard Serial Port A.
Choices; auto; Disabled; 3F8/COM1; 2F8/COM2;
3E8/COM3; 2E8/COM4;
- Onboard Serial Port B** Allows you to set the Onboard Serial Port B.
Choices; auto; Disabled; 3F8/COM1; 2F8/COM2;
3E8/COM3; 2E8/COM4;
- Serial Port B Mode** Allows you to set the Serial Port B Mode.
Choices: Normal; 1.6 uS; 3/16 Baud; ASKIR;
- IR Duplex Mode** If Serial Port B is not at Normal mode, this item allows you to set the Serial Port B to Half or Full Duplex.
- IR Pin Select** If Serial Port B is not at Normal mode, this item allows you to set the Serial Port B Pin to IRRX/IRTX or SINB/SOUTB.
- OnBoard Parallel Port** Allows you to configure onboard Parallel port .
Choices: auto; Disabled; 378; 278; 3BC;
- Parallel Port Mode** If Parallel Port is not disabled, this item allows you to configure port mode.
Choices: Normal; B:-Dir; EPP; ECP

- EPP Version** If Parallel Port Mode is EPP, this item allows you to set the EPP Version.
Choices: 1.9; 1.7
- Parallel Port IRQ** If Parallel Port Mode is set at EPP, this item allows you to set the Parallel Port IRQ.
Choices: 5; 7
- Parallel Port DMA Channel** If Parallel Port Mode is set at ECP, this item allows you to set the DMA Channel.
Choices: 0; 1; 3
- Primary/Secondary Master/Slave Prefetch** Allows you to enable / disable the PCI IDE prefetch function of the PCI IDE channels. Default: Enabled
- OnBoard MIDI Port** Allows you to configure onboard MIDI port .
The choices: Disabled; 300h; 310h; 320h; 330h
- MIDI IRQ Select** If the onboard MIDI port is set at 300h or 380h, this item appears to allow you to configure the MIDI Port IRQ.
The choices: 3; 4; 5; 7; 10; 11
- OnBoard Game Port** Allows you to configure Onboard Game port address.
The choices: Disabled; 200h; 208h
- PS/2 Keyboard Power On Function** Allows you to configure the Keyboard PowerOn Function.
Choices: Disabled; Specific Key.
- Specific Key for PowerOn** If Keyboard PowerOn function is set at Specific Key, this item allows you to type a password with the keyboard for Power On.
- PS/2 Mouse PowerOn Function** Allows you to disable or use the mouse to power on system..
choices: Disabled; Right Botton; Left Button

4-6.8 Hardware Monitor Status

This menu helps you to read only and get more information on the working CPU temperature, FAN speed and voltage.

1. Choose “Hardware Monitor Status” from the Main Menu and a screen with a list of current status of your working system will appear:

AMIBIOS EASY SETUP UTILITY - VERSION 2.01a

Hardware Monitor Status	Setup Help
CPU1 Temperature	
CPU2 Temperature	
System Temperature	
CPU Fan Speed	
Case Fan Speed	
Power Fan Speed	
Vcore	
+3.3V	
+5V	
-5V	
+12V	
-12V	
Battery	
+5V SB	

↑↓ : Select Item
Esc: Previous Menu

+/- : Change Values
Enter: Select ▶ Sub-Menu

F6: Setup Defaults
F10: Save & Exit

2. Press <ESC> to return to the Main Menu. in case any irregular reading appears about your system, it indicates that a problem exists therein. To solve the problem, a hardware professional or your dealer is recommended.

CPU1 Temperature Shows current temperature of the CPU body.

CPU 2 Temperature Shows current temperature round the CPU.

System Temperature Shows current system temperature.

CPU Fan Speed Displays the current speed of CPU Fan.

Case Fan Speed Shows current Case Fan Speed.

Power Fan Speed Shows current Power Fan Speed.

Vcore Shows CPU core actual voltage value.

+3.3V Shows current voltage against the +3.3V power supply.

±5V Shows current voltage against the ±5V power supply.

±12V Shows current voltage against the ±12V power supply.

Battery Shows current voltage against battery power supply.

+5V SB Shows current voltage against the +5V SB power supply.

4-6.9 Frequency/Voltage Control

Run the “Frequency/Voltage Control” as following:

1. Choose “Frequency/Voltage Control” from the Main Menu and a screen with a list of options will appear:

AMIBIOS EASY SETUP UTILITY - VERSION 2.01a

Frequency/Voltage Control		Setup Help
Redstorm Overlocking Tech (optional)	Press Enter	
CPU Linear Freq	Disabled	
CPU Clock	100 MHz	
CPU Ratio Selection	Locked	
PCI Clock Auto Detection	Disabled	
Spread Spectrum Selection	Disabled	

↑↓ : Select Item
Esc: Previous Menu

+/- : Change Values
Enter: Select ▶ Sub-Menu

F6: Setup Defaults
F10: Save & Exit

2. Use one of the arrow keys to move between options and modify the selected options by using PgUp / PgDn / + / - keys. An explanation of the <F> keys follows:

<F1>: “Help” gives options available for each item.

<F6>: Setup BIOS default values.

<F10>: Save and Exit Setup.

3. Press <ESC> to return to the Main Menu when you finish setting up all items. The following item descriptions are provided as a quick guide to your setup.

(optional) Press <Enter> to start *RED STORM OVERCLOCKING TECH*. This option gives user an easy way to **Redstorm Overclocking** **Tech** overclocking. It will raise CPU clock automatically. When CPU clock is raised to an unacceptable value, BIOS will restart your system, then running at an acceptable higher CPU clock.

CPU Linear Freq This item allows you to enable / disable this setting function.

CPU Clock If CPU Linear Frequency is set at Enabled, this item allows you to set CPU Clock.
Choices: 100MHz ~200MHz in 1MHz stepping.

CPU Ratio Selection If CPU onboard is one with an adjustable CPU ration, this item allows you user to adjust the CPU Ratio.

PCI Clock Auto Detection Allows you to enable / disable this auto detection function.

Spread Spectrum Selection Allows you to enable / disable this Spread Spectrum Selection function.

4-6.10 Set Supervisor Password

This option allows you to set a Supervisor password for the system:

1. Choose “Set Supervisor Password” in the Main Menu and press <Enter>. Then the following message appears:

[Enter new supervisor password]

2. The first time you run this option, enter your password up to 8 characters and press <Enter>. (The screen does not display the entered characters.)
3. After you enter the password, the following message appears prompting you to confirm the password:

[Retype new supervisor Password]

4. Enter the same password “exactly” the same as you have just typed to confirm the password and press <Enter>.
5. The following message appears to confirm the new password setup.

[New supervisor password installed]

Any Key to Continue

6. Then press any key to continue your CMOS Setup. To save the password setup, you should press “Save & Exit Setup” and choose “yes” to exit and save setup.

NOTE: If you forget or lose the password, the only way to access the system is to clear the CMOS RAM. All setup informations will be lost and you need to run the BIOS setup program again.

4-6.11 Load Optimized Defaults

When you press <Enter> on this item, you will get a confirmation dialog box with a message similar to:

[Load Optimal Defaults]

**Press [Enter] to continue
or [ESC] to abort**

Press <Enter> now to load Optimal values for all the Setup options.

4-6.12 Save & Exit Setup

Save & Exit Setup allows you to save all modifications you have specified into the CMOS memory. Highlight this option on the Main Menu and press <Enter>. The following message appears:

[Saving current settings and exit]

**Press [Enter] to continue
or [ESC] to abort**

Press <Enter> key to save the configuration changes and exit CMOS Setup to restart your system.

4-6.13 Exit Without Saving

Exit Without Saving option allows you to exit the Setup Utility without saving the modifications that you have specified. Highlight this option on the Main Menu and the following message appears:

[Quit Without Saving Changes]

**Press [Enter] to continue
or [ESC] to abort**

Follow the message and press <Enter> key to exit CMOS Setup and restart system.