

PCA-6770 Series

Socket 370 Pentium® III/Celeron™
Half-size SBC with AGP/VGA/LCD,
Ethernet and SSD

User's Manual

Copyright Notice

This document is copyrighted, 1999. All rights are reserved. The original manufacturer reserves the right to make improvements to the products described in this manual at any time without notice.

No part of this manual may be reproduced, copied, translated or transmitted in any form or by any means without the prior written permission of the original manufacturer. Information provided in this manual is intended to be accurate and reliable. However, the original manufacturer assumes no responsibility for its use, nor for any infringements upon the rights of third parties which may result from its use.

Acknowledgements

Award is a trademark of Award Software International, Inc.
IBM, PC/AT, PS/2 and VGA are trademarks of International Business Machines Corporation.

Intel and Pentium are trademarks of Intel Corporation.

Microsoft Windows® is a registered trademark of Microsoft Corp.

UMC is a trademark of United Microelectronics Corporation.

All other product names or trademarks are properties of their respective owners.

For more information on this and other Advantech products please visit our website at: **<http://www.advantech.com>**
<http://www.advantech.com/epc>

For technical support and service for please visit our support website at: **<http://support.advantech.com>**

This manual is for the PCA-6770 Series Rev. A1 & B1

Part No. 2006677002

3rd Edition

Printed in Taiwan

Oct 2001

Packing List

Before installing your board, ensure that the following materials have been received:

- 1 PCA-6770 all-in-one single board computer
- 1 hard disk drive (IDE) interface cable (44-pin) p/n: 1701440350
- 1 floppy disk drive interface cable (34-pin)
p/n: 1701340600
- 1 parallel port cable (26-pin) p/n: 1700260250
- 1 COM port cable (9-pin) p/n: 1700100250
- 1 6-pin mini-DZN keyboard & PS/2 mouse adaptor
p/n: 1700060201
- 1 ATX/AT power cable p/n: 1700000450
- 1 CPU cooling fan p/n: 1759200310
- 1 startup manual
- CD-ROM or disks for utility, drivers, and manual (in PDF format)
- Warranty certificate

Note 1: For detailed contents of the PCA-6770, please refer to the enclosed CD-ROM or disk (in PDF format).

If any of these items are missing or damaged, contact your distributor or sales representative immediately.

Optional Devices

- IrDA adapter (part#: 9689000042)
- 1 USB cable (part #1700100170)

Contents

Chapter 1	General Information	1
1.1	Introduction	2
1.2	Specifications	3
1.3	Features	5
1.4	Board Layout: Dimensions	6
Chapter 2	Installation	7
2.1	Safety Precautions	8
2.2	Jumpers	9
2.3	Connectors	10
2.4	Locating Connectors	11
2.4.1	Component Side	11
2.4.2	Solder Side	12
2.5	Locating Jumpers	13
2.5.1	Component Side	13
2.6	Setting Jumpers	14
2.7	CMOS clear (JP1)	15
2.8	Watchdog timer (JP2)	16
2.9	COM2 settings for RS-232/422/485 (JP5)	17
2.10	Power type select (JP3)	17
2.11	LCD Panel select (SW1)	18
2.12	LCD Panel select (SW1)	19
2.13	Installation caution	20
2.14	Enhanced IDE connector (CN1)	21
2.15	Parallel Port connector (CN2)	22
2.16	ATX Power connector (CN3)	22
2.17	AT Power connector (CN4)	23
2.18	LCD inverter connector (CN5)	23
2.19	Floppy drive connector (CN6)	24
2.20	Reset switch (CN7)	24
2.21	IR connector (CN8)	24
2.22	Keyboard lock (CN9)	25
2.23	Hard disk drive LED (CN10)	25
2.24	ATX power button (CN11)	25

2.25	External speaker (CN12)	25
2.26	USB connector (CN13)	26
2.27	Flat panel display connector (CN14).....	26
2.28	Ext. flat panel display connector (CN15).....	26
2.29	VGA display connector (CN16)	27
2.30	Ethernet configuration (CN18)	27
2.31	CPU fan power supply connector (CN19)	28
2.32	RS-232 connection (COM1- CN22)	28
2.33	RS-232/422/485 connection (COM2- (CN21 RS-232; CN20: RS-422/485)	
2.34	External keyboard (CN25)	29
2.35	Keyboard & PS/2 Mouse connector (CN26)	30
2.36	CompactFlash Disk (CN27)	30
2.37	Installing System memory (SODIMMs)	30
	2.37.1 Installing SODIMMs	30
2.36	CPU installation and upgrading	32
Chapter 3 Award BIOS Setup		33
3.1	AWARD BIOS Setup	34
3.1.1	Entering setup	34
3.1.2	Standard CMOS setup	35
3.1.3	BIOS features setup	36
3.1.4	CHIPSET features setup	40
3.1.5	Power management setup	41
3.1.6	PnP PCI configuration setup	42
3.1.7	Load BIOS defaults	42
3.1.8	Load setup defaults	42
3.1.9	Integrated Peripherals	43
3.1.10	Password setting	43
3.1.11	IDE HDD auto detection	44
3.1.12	Save & exit setup	44
3.1.13	Exit without saving	44
Chapter 4 AGP SVGA Setup		45
4.1	Introduction	46
4.2	Installation of SVGA driver	47
4.2.1	Installation for Windows 3.1	48
4.2.2	Installation for Windows 95/98	50

4.2.3	Installation for Windows NT	53
4.3	Further Information	55
Chapter 5	PCI Bus Ethernet Interface	57
5.1	Introduction	58
5.2	Installation of Ethernet Driver	58
5.2.1	Installation for MS-DOS & Windows 3.1	58
5.2.2	Installation for Windows 95/98	59
5.2.3	Installation for Windows NT	61
5.3	Further Information	57
Appendix A	Programming the Watchdog Timer	65
A.1	Programming the Watchdog Timer	66
Appendix B	Installing PC/104 Modules	69
B.1	Installing PC/104 modules	70
Appendix C	Pin Assignments	73
C.1	IDE Hard drive Connector (CN1)	74
C.2	Parallel Port Connector (CN2)	75
C.3	ATX power Connector (CN3)	76
C.4	AT power Connector (CN4)	76
C.5	LCD power inverter (CN5)	77
C.6	Floppy drive connector (CN6)	77
C.7	Reset switch connector (CN7)	78
C.8	IR Connector (CN8)	78
C.9	Keyboard lock Connector (CN9)	78
C.10	IDE LED Connector (CN10)	79
C.11	ATX power switch (CN11)	79
C.12	External speaker connector (CN12)	79
C.13	USB1/USB2 connector (CN13)	80
C.14	Flat panel display Connector (CN14)	81
C.15	Ext. flat panel display Connector (CN15)	82
C.16	CRT display Connector (CN16)	82
C.19	CPU Fan power Connector (CN19)	83

C.20	COM2 RS-422/485 Serial Port (CN20)	83
C.21	COM2 RS-232 Serial Port (CN21)	84
C.22	COM1 RS-232 Serial Port (CN22)	84
C.25	External keyboard connector (CN25)	85
C.26	Keyboard and mouse connector (CN26)	85
C.27	CompactFlash Card connector (CN27)	86
Appendix D System Assignments		87
D.1	System I/O Ports	88
D.2	DMA Channel Assignments	89
D.3	Interrupt Assignments	89
D.4	1st MB Memory Map	90

Tables

Table 2-1:	Jumpers	9
Table 2-2:	Connectors	10
Table 2-3:	RTC power and CMOS clear (JP1)	15
Table 2-4:	Watchdog timer system reset (JP2)	16
Table 2-5:	COM2 settings for RS-232/422/485 (JP5)	17
Table 2-6:	Power type select (JP3)	17
Table 2-9:	LCD Panel select (SW1)	18
Table 2-3:	RTC power and CMOS clear (JP1)	15
Table B-1:	PC/104 connectors (CN12)	72
Table D-1:	System I/O ports	88
Table D-2:	DMA channel assignments	89
Table D-3:	Interrupt Assignments	89
Table D-4:	1st memory map	90

Figures

Figure 1-1: PCA-6770 board layout Dimensions	6
Figure 2-1: Locating Connectors (component side)	11
Figure 2-2: Locating Connectors (Solder side)	12
Figure 2-3: Locating Jumpers	13
Figure 2-4: ATX Adaptor cable	23
Figure 3-1: Award Bios setup	34
Figure 3-2: Standard CMOS setup	35
Figure 3-3: Bios features setup	36
Figure 3-4: Chipset features setup	40
Figure 3-5: Power management setup screen	41
Figure 3-6: PCI configuration screen	42
Figure 3-7: Integrated peripherals	43
Figure 3-8: Exiting	44
Figure B-1: PC/104 module mounting diagram	65
Figure B-2: PC/104 module dimensions (mm) (± 0.1)	65

CHAPTER 1

General Information

This chapter gives background information on the PCA-6770.

Sections include:

- Introduction
- Features
- Specifications
- Board layout and dimensions

1.1 Introduction

The PCA-6770 all-in-one industrial grade PCI-bus CPU card uses Intel's highly acclaimed Celeron® processor or Pentium® III processor, together with the Intel 440BX PCI chipset.

The CPU provides 256 KB for Pentium III or 128 KB on-CPU L2 cache for Celeron, eliminating the need for external SRAM chips. It has one PCI EIDE interface for up to two devices and a floppy disk drive interface for up to two devices. Other features include two RS-232 serial ports (16C550 UARTs with 16-byte FIFO or compatible), one enhanced parallel port (supports SPP/EPP/ECP) and one USB (Universal Serial Bus) port. The PCI enhanced IDE controller supports Ultra DMA/33 and PIO Mode 4 operation. This provides data transfer rates of over 33 MB/sec. System Bios supports boot-up from an IDE CD-ROM, SCSI CD-ROM and LS-120.

A backup of CMOS data is stored in the Flash memory, which protects data even after a battery failure. Also included is a 62-level Watchdog timer which resets the CPU or generates an interrupt if a program cannot be executed normally. This enables reliable operation in unattended environments.

The PCA-6770 offers several impressive industrial features such as VGA AGP controller, two SODIMM slots for a total of 256 MB RAM memory and a 10/100Base-T networking controller. In addition, the PCA-6770 series supports a solid state disk (SSD) using a CompactFlash™ disk that is not as vulnerable to the hazards of an industrial computing environment. These features make it an ideal choice for applications that require both high performance and full functionality.

1.2 Specifications

CPU: Socket 370 for Intel® Pentium III processors up to 650 MHz or higher in the future (Rev. B1 only) and Celeron™ processors up to 500 MHz

- **BIOS:** 2/4 Mbit Flash BIOS, supports Plug & Play, APM 1.2
Support Ethernet Boot ROM
Support boot from CD-ROM
Support boot from LS-120 ZIP™ Drive
Optional Customer icon
- **Chipset:** Intel® 440BX AGP set, FSB 66/100 MHz
- **2nd level cache:** 256 KB on Pentium III and 128 KB on Celeron™ Processor
- **System memory:** Two SODIMM sockets, support 8 MB to 256 MB, accepts 8/16/32/64/128 MB Synchronous DRAM
- **PCI IDE interface:** One Enhanced IDE interface, supports 2 IDE devices PIO mode 3,4 with bus mastering up to 14 MB/sec. Ultra DMA model up to 33 MB/sec.
- **Floppy disk drive interface:** Supports up to two FDDs (360 KB/1.2 MB/720 KB/1.44 MB/2.88 MB)
- **Parallel port:** One parallel port, supports EPP/ECP
- **IR port:** One 115 kbps IrDA compliant serial infrared
- **Serial ports:** 2 serial ports
COM1: RS-232, COM2: RS-232/422/485
- **Watchdog timer:** 62 levels timer interval, setup by software, jumperless selection, generates system reset or IRQ11

AGP SVGA/Flat Panel Interface

- **Chipset:** C&T 69000, 64-bit graphics engine
- **Flat panel performance:** 36-bit direct interface to mono, STN,

DSTN & TFT panels. Advanced power management. Supports 3.3 V or 5 V Flat panel display.

AGP SVGA/Flat Panel Interface cont.

- **Interface:** 1 x AGP, Accelerator graphics ports 1.0 compliant

- **Display mode:**

Flat panel: up to 800 x 600 @ 24 bpp

1024 x 768 @ 16 bpp

1280 x 1024 @ 8 bpp

CRT display: up to 800 x 600 @ 24 bpp

1080 x 768 @ 16 bpp

1280 x 1024 @ 8 bpp

- **Display memory:**

2 MB of SDRAM on C&T69000

Ethernet Interface

- RealTek™ RTL 8139 chip
PCI Ethernet controller, IEEE 802.3 protocol compatible
Supports 10/100 Mbps base-T

Power Management

- Supports Advanced Power Management

Solid State Disk

- Supports ATA CompactFlash™ disk (IDE interface)

Keyboard/Mouse connector

- 6-pin Mini-Din header connector for keyboard and PS/2 mouse

On-board Security

- CPU over temperature

Mechanic and Environmental Specifications

- Standard mode power consumption
4.73 A @ 5 V with Celeron™ 466, 128 MB SO DIMM
- **Operating temperature:**
0 ~ 60° C (32 ~ 140° F)
- **Size:** 185 mm x 122 mm
- **Weight:** 0.26 kg

1.3 Features

- Supports Socket 370 for Intel® Pentium III/Celeron™ processor
- AGP 3D VGA/LCD and supports 36 bit XGA TFT LCD Panel
- USB interface compliant with USB rev. 1.0
- SIR support
- System overheat temperature control
- 62-levels Watchdog timer, jumperless on-line setup supported
- Supports wake-up on LAN, Modem
- Supports turn off LCD back light function
- Supports PCI interface compliant with PCI rev. 2.1
- Supports four PCI Bus masters

1.4 Board layout: Dimensions

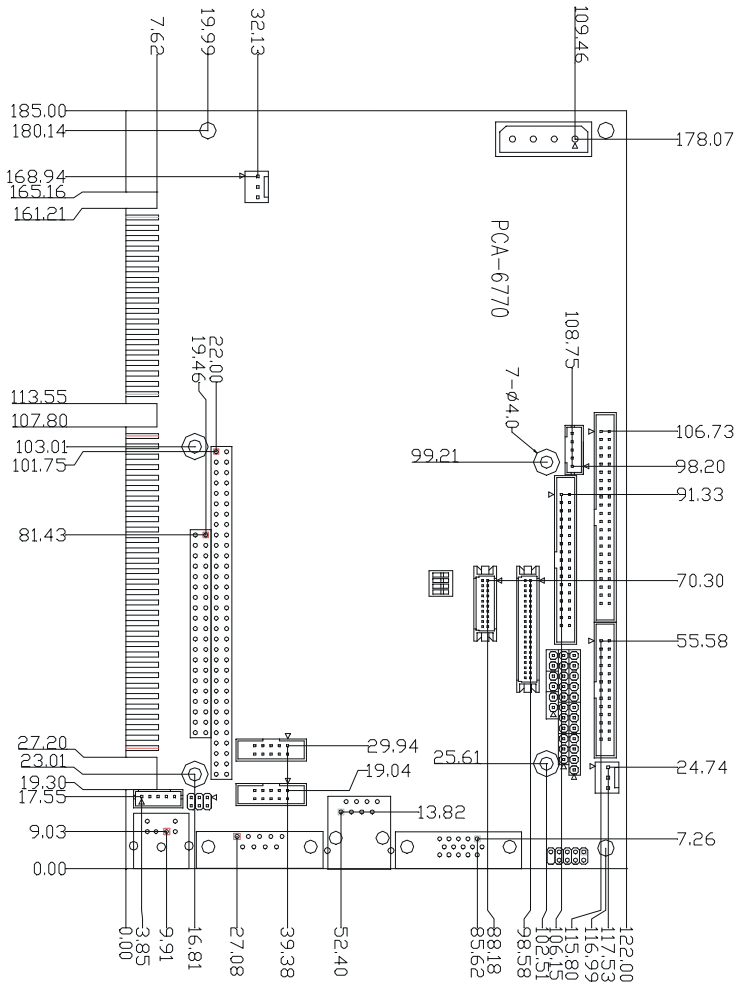

Figure 1-1: PCA-6770 (dimensions)

CHAPTER 2

Installation

This chapter tells how to set up the PCA-6770 hardware. It includes instructions on setting jumpers, and connecting peripherals, switches and indicators. Be sure to read all the safety precautions before you begin the installation procedure.

2.1 Safety Precautions

Follow these simple precautions to protect yourself from harm and your PC from damage.

1. To avoid electric shock, always disconnect the power from your PC chassis before you work on it. Don't touch any components on the CPU card or other cards while the PC is on.
2. Disconnect power before making any configuration changes. The sudden rush of power as you connect a jumper or install a card may damage sensitive electronic components.
3. Always ground yourself to remove any static charge before you touch your CPU card. Be particularly careful not to touch the chip connectors. Modern integrated electronic devices, especially CPUs and memory chips, are extremely sensitive to static electric discharges and fields. Keep the card in its antistatic packaging when it is not installed in the PC, and place it on a static dissipative mat when you are working with it. Wear a grounding wrist strap for continuous protection.

2.2 Jumpers

The PCA-6770 has a number of jumpers that allow you to configure your system to suit your application. The table below lists the function of each of the board's jumpers.

TABLE 2-1: JUMPERS

Label	Function
JP1	CMOS clear
JP2	Watchdog timer action
JP3	Power type select
JP5	COM2 RS-232/422/485 setting
SW1	Panel type select

2.3 Connectors

On-board connectors link the PCA-6770 to external devices such as hard disk drives, a keyboard, or floppy drives. The table below lists the function of each of the board's connectors.

Label	Function
CN1	IDE hard drive connector
CN2	Parallel port connector
CN3	ATX feature connector
CN4	Main power connector
CN5	LCD inverter power
CN6	Floppy drive connector
CN7	Reset connector
CN8	IR connector
CN9	Keyboard Lock connector
CN10	External IDE LED
CN11	ATX power switch button
CN12	Speaker connector
CN13	USB channel 1, 2 connector
CN14	Flat panel connector
CN15	Ext. flat panel display connector
CN16	CRT display connector
CN18	Ethernet 100/10Base-T connector
CN19	Fan power connector
CN20	COM2, 422/485 connector
CN21	COM2, 232 connector
CN22	COM1, 232 connector
CN25	EXT keyboard connector
CN26	Keyboard and PS/2 mouse connector
CN27	CFC connector

2.4 Locating connectors

2.4.1 Component side

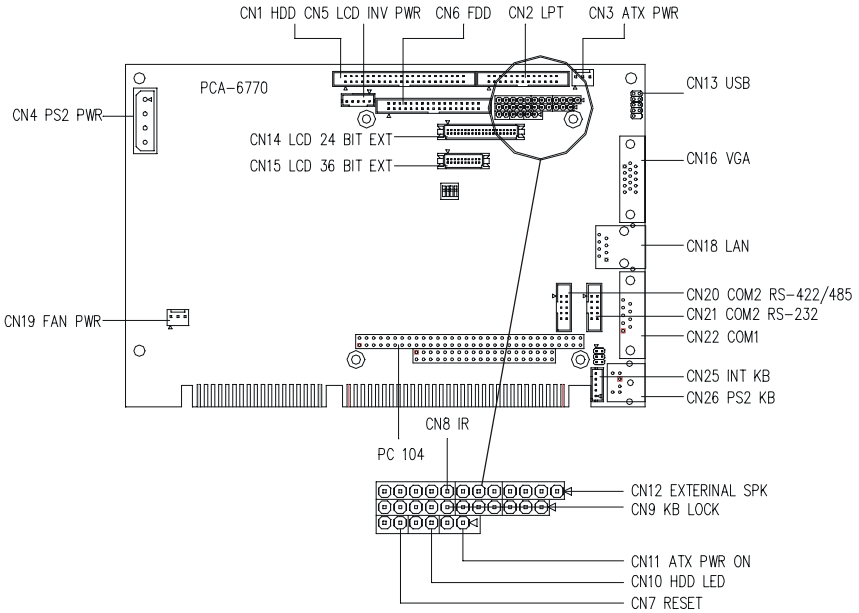

Figure 2-1: Locating connectors (component side)

2.4 Locating Connectors

2.4.2 Solder side

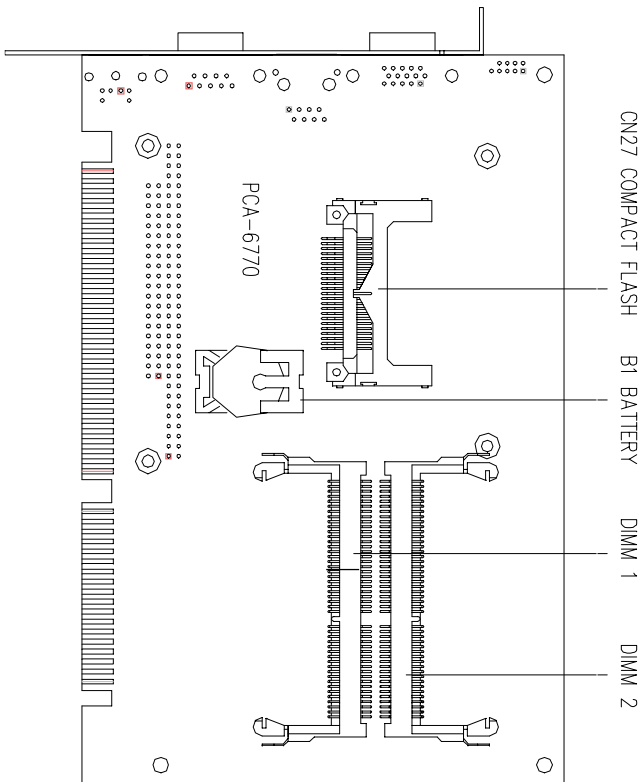

Figure 2-2: Locating connectors (solder side)

2.5 Locating Jumpers

2.5.1 Component side

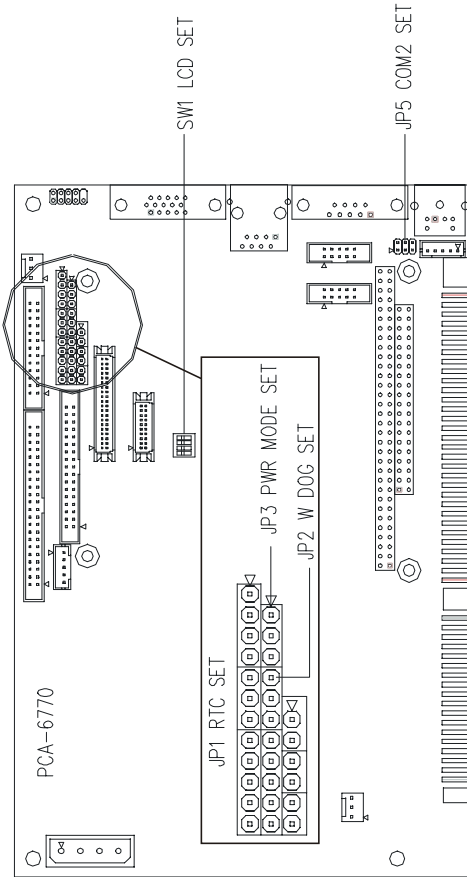
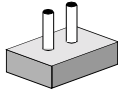

Figure 2-3: Locating Jumpers

2.6 Setting jumpers

You configure your card to match the needs of your application by setting jumpers. A jumper is the simplest kind of electric switch. It consists of two metal pins and a small metal clip (often protected by a plastic cover) that slides over the pins to connect them. To “close” a jumper, connect the pins with the clip. To “open” a jumper, remove the clip. Sometimes a jumper will have three pins, labeled 1, 2, and 3. In this case, you would connect either pins 1 and 2 or 2 and 3.



Open

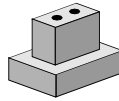

Closed

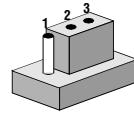

Closed 2-3

The jumper settings are schematically depicted in this manual as follows:



Open



Closed

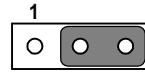

Closed 2-3



A pair of needle-nose pliers may be helpful when working with jumpers. Setting switches is slightly different but more simple. Simply slide the desired switch to the **on** or **off** position. In the example below, the 6 element switch would be. 1:off, 2:on, 3:off, 4:off, 5:off, 6:off.



If you have any doubts about the best hardware configuration for your application, contact your local distributor or sales rep

2.7 CMOS clear function (JP1)

Warning: To avoid damaging the computer, always turn off the power supply before setting "Clear CMOS". Set the jumper back to normal before turning on the power supply.

TABLE 2-3. RTC POWER AND CMOS CLEAR (JP1)		
	*Normal	CMOS data clear
JP1		

* default setting

2.8 Watchdog timer config. (JP2)





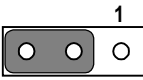
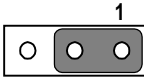



An on-board watchdog timer reduces the chance of disruptions which EMP (electro-magnetic pulse) interference can cause. This is an invaluable protective device for standalone or unmanned applications. Setup involves two jumpers and running the control software. (Refer to Appendix A.)

When the watchdog timer is enabled and the CPU shuts down, the watchdog timer will automatically either reset the system or generate an interrupt on IRQ 11, depending on the setting of jumper JP2, as shown below:

TABLE 2-4.	WATCHDOG	TIMER	SYSTEM	RESET	SELECT	(JP2)
	*System Reset			IRQ 11 interrupt		
JP2						

* default setting

2.9 COM2 settings for RS-232/422/485 (JP5)

TABLE 2-5: COM2 SETTINGS FOR RS-232/422/485 (JP3)			
	*RS-232	RS-422	RS-485
JP3	1  2	1  2	1  2
	3  4	3  4	3  4
	5  6	5  6	5  6

* default setting

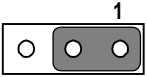
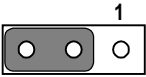

2.10 Power type select (JP3)

TABLE 2-6: POWER TYPE SELECT (JP3)		
	ATX Power	*AT Power
JP4		

* default setting



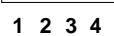

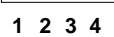
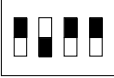
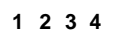
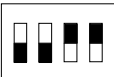
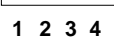
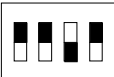
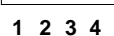
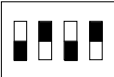
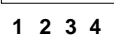
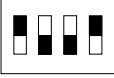
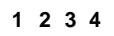
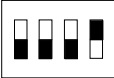
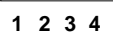



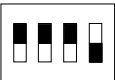

2.11 LCD Panel select (JP4)

TABLE 2-9. PANEL TYPE SELECT (SW1)

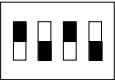
Display	TYPE	Setting (SW1)
1024 x 768	Dual scan STN	On  Off  1 2 3 4
1280 x 1024	TFT color	On  Off  1 2 3 4
640 x 480	Dual scan STN	On  Off  1 2 3 4
800 x 600 36 bits	Dual scan STN	On  Off  1 2 3 4
640 x 480	Sharp TFT color	On  Off  1 2 3 4
640 x 480	18-bit TFT color	On  Off  1 2 3 4
1024 x 768	TFT color	On  Off  1 2 3 4
800 x 600	TFT color	On  Off  1 2 3 4

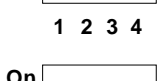
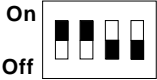
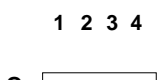
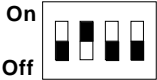
2.12 LCD Panel select (JP4)

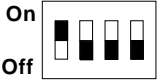
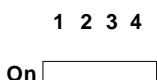
TABLE 2-9. PANEL TYPE SELECT (SW1)

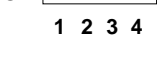
Display	TYPE	Setting (SW1)
800 x 600	TFT color	On  Off  1 2 3 4
800 x 600	TFT color	On  Off  1 2 3 4
800 x 600	Dual scan STN color	On  Off  1 2 3 4
800 x 600	Dual scan STN color	On  Off  1 2 3 4
1024 x 768	TFT color	On  Off  1 2 3 4
1280 x 1024	Dual scan STN	On  Off  1 2 3 4
1024 x 600	Dual scan STN	On  Off  1 2 3 4
1024 x 600	TFT color	On  Off  1 2 3 4

2.13 Installation Caution

The following sections tell how to make each connection. In most cases, you will simply need to connect a standard cable. All of the connector pin assignments are shown in Appendix C.

Warning! *Always completely disconnect the power cord from your chassis whenever you are working on it. Do not make connections while the power is on. Sensitive electronic components can be damaged by a sudden rush of power. Only experienced electronics personnel should open the PC chassis.*



Caution! *Always ground yourself to remove any static charge before touching the CPU card. Modern electronic devices are very sensitive to static electric charges. Use a grounding wrist strap at all times. Place all electronic components on a static-dissipative surface or in a static-shielded bag when they are not in the chassis.*



2.14 Enhanced IDE Connector (CN1)

You can attach two IDE (Integrated Device Electronics) drives to the PCA-6770's internal controller. The PCA-6770 CPU card has an EIDE connector, CN1.

Wire number 1 on the cable is red or blue, and the other wires are gray. Connect one end to connector CN1 on the CPU card. Make sure that the red (or blue) wire corresponds to pin 1 on the connector (on the right side). See Chapter 1 for help in finding the connector.

Unlike floppy drives, IDE hard drives can connect in either position on the cable. If you install two drives, you will need to set one as the master and one as the slave. You do this by setting the jumpers on the drives. If you use just one drive, you should set it as the master. See the documentation that came with your drive for more information.

Connect the first hard drive to the other end of the cable. Wire 1 on the cable should also connect to pin 1 on the hard drive connector, which is labeled on the drive circuit board. Check the documentation that came with the drive for more information.

Connect the second drive, as described above, on CN1.

2.15 Parallel Port Connector (CN2)

The parallel port is normally used to connect the CPU card to a printer. The PCA-6770 includes an on-board parallel port, accessed through a 26-pin flat-cable connector, CN2. The card comes with an adapter cable which lets you use a traditional DB-25 connector. The cable has a 26-pin connector on one end and a DB-25 connector on the other, mounted on a retaining bracket. The bracket installs at the end of an empty slot in your chassis, giving you access to the connector.

The parallel port is designated as LPT1, and can be disabled or changed to LPT2 or LPT3 in the system BIOS setup.

To install the bracket, find an empty slot in your chassis. Unscrew the plate that covers the end of the slot. Screw in the bracket in place of the plate. Next, attach the flat-cable connector to CN2 on the CPU card. Wire 1 of the cable is red or blue, and the other wires are gray. Make sure that wire 1 corresponds to pin 1 of CN2. Pin 1 is on the right side of CN2.

2.16 ATX Power Connector (CN3)

When the PCA-6770 is used as a stand alone card, both the 4-pin main power connector (CN4) and the ATX feature connector (CN3) must be connected to the power supply. If the PCA-6770 is used with a passive backplane, the main power connector (CN4) should not be connected as the card will be powered from the backplane.

The ATX adapter cable (provided) is used to connect the PCA-6770 to the ATX power supply. The ATX adapter cable has different connectors at both ends. On one end is the ATX 20-pin (female type) which connects to the (male) ATX power supply source. The other end has a 3-pin connector (female type) which connects to the ATX feature connector (CN3) on the board itself. This end also has the 6-pin main power connector (P8) and a 6-pin connector (P9) which is used when the board is mounted on a passive backplane.

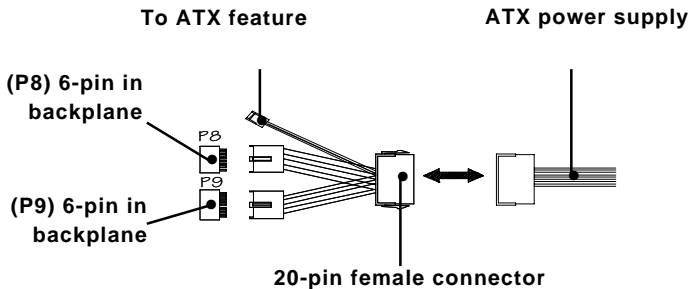

Figure 2-4: ATX Adaptor cable

2.17 AT Power Connector (CN4)

If you prefer not to acquire power through PCA-6770's backplane via the gold H-connectors, CN4 also provides power input connectors for +5 V and +12 V. (see Appendix C)

2.18 LCD Inverter Connector (CN5)

The LCD inverter is connected to CN5 via a 5-pin connector to provide +12 V power to the LCD display. The pin assignments for CN5 can be found in Appendix C.

2.19 Floppy Drive Connector (CN6)

You can attach up to two floppy disk drives to the PCA-6770's on-board controller. You can use any combination of 5.25" (360 KB/1.2 MB) and/or 3.5" (720 KB/1.44/2.88 MB) drives.

The card comes with a 34-pin daisy-chain drive connector cable. On one end of the cable is a 34-pin flat-cable connector. On the other end are two sets of floppy disk drive connectors. Each set consists of a 34-pin flat-cable connector (usually used for 3.5" drives) and a printed-circuit-board connector (usually used for 5.25" drives). You can use only one connector in each set. The set on the end (after the twist in the cable) connects to the A: floppy. The set in the middle connects to the B: floppy.

2.20 Reset switch (CN7)

If you install a reset switch, it should be a single pole switch rated at 10 mA, 5 V. Momentarily pressing the switch will activate a reset.

For reset switch pin assignments, please see Appendix C.

2.21 IR Connector (CN8)

This connector supports the optional wireless infrared transmitting and receiving module. This module mounts on the system case. You must configure the setting through BIOS setup.

2.22 Keyboard Lock (CN9)

Connecting CN9 enables the keyboard locking function from the front panel of your chassis.

2.23 Hard disk drive LED (CN10)

You can connect an LED to connector CN10 to indicate when the HDD is active. Marks on the circuit board indicate LED polarity.

2.24 ATX power button (CN11)

The PCA-6770 provides an ATX power input connector. When connected with the ATX power switch, the ATX power switch connector (CN11) enables power On/Off from the chassis.

2.25 External Speaker (CN12)

Connect external speakers to CN12. To activate the on-board buzzer, set the connector so that Pins 3 and 4 are closed.

2.26 USB Connector (CN13)

The PCA-6770 board provides two USB (Universal Serial Bus) interfaces, which give complete plug and play and also hot attach/detach for up to 127 external devices. The USB interfaces comply with USB specification rev. 1.0 and are fuse protected.

The USB interfaces are accessed through a 10-pin flat-cable connector, CN13. The adapter cable has a 10-pin connector on one end and a USB connector on the bracket.

The USB interfaces can be disabled in the system BIOS setup.

2.27 Flat panel Display Connector (CN14)

CN14 is a 40-pin connector which can support a 24-bit TFT LCD. It is Hirose's product no. DF13A-40DP-1.25V.

The PCA-6770 provides a bias control signal on CN14 that can be used to control the LCD bias voltage. It is recommended that the LCD bias voltage not be applied to the panel until the logic supply voltage (+5 V or +3.3 V) and panel video signals are stable. Under normal operation, the control signal (ENAVEE) is active high. When the PCA-6770's power is applied, the control signal is low until just after the relevant flat panel signals are present.

2.28 Ext.flat panel Display Connector (CN15)

CN15 consists of a 20-pin header, which is Hirose's product no. DF13A-20DP-1.25V. The PCA-6770 supports a 36-bit LCD panel with connections to both CN14 and CN15. For details of pin assignments, refer to Appendix C.

2.29 VGA Display Connector (CN16)

The PCA-6770 provides a VGA controller for a high resolution VGA interface. The PCA-6770 CN12 is a DB-15 connector for VGA monitor input. Pin assignments for the CRT display are detailed in Appendix C.

2.30 Ethernet Configuration (CN18)

The PCA-6770 is equipped with a high performance 32-bit PCI-bus Fast Ethernet interface which is fully compliant with IEEE 802.3u 10/100Base-T specifications. It is supported by all major network operating systems.

The medium type can be configured via the RSET8139.EXE program included on the utility disk. (See Chapter 5 for detailed information.)

RJ-45A connector (CN14)

10/100Base-T connects to the PCA-6770 via an adapter cable to the RJ-45 standard jack.

Network boot

The network boot feature is built into the BIOS. It can be enabled or disabled in the chipset setup of the CMOS configuration. Refer to "BIOS Setting" in Chapter 3 for more information.

2.31 CPU Fan Power Supply Connector (CN19)

The CN19 provides power supply to the optional CPU cooling fan. This connector is only available when +5 V and +12 V power is supplied to the board.

Warning! *Before making the connection, make sure the voltage is absolutely correct and matched with the correct connector.*

2.32 RS-232 connection (COM1-CN22)

Different devices implement the RS-232 standard in different ways. If you are having problems with a serial device, be sure to check the pin assignments for the connector.

2.33 RS-232/422/485 connection (COM2-CN21: RS-232; CN20: RS-422/485)

COM2 is an RS-232/422/485 serial port. The specific port type is determined by jumper settings (JP5), as detailed in Chapter 1.

The IRQ and address range for both ports are fixed. However, if you wish to disable the port or change these parameters later, you can do this in the system BIOS setup. The table below shows the settings for the PCA-6770 board's ports:

Port	Address	Interrupt	Default
COM1	3F8, 3E8	IRQ4	3F8
COM2	2F8, 2E8	IRQ3	2F8

2.34 External Keyboard (CN25)

In addition to the PS/2 mouse/keyboard connector, an additional external keyboard connector is provided.

For external keyboard pin assignments, please see Appendix C.

2.35 Keyboard & PS/2 Mouse Connector (CN26)

The PCA-6770 board provides a keyboard connector. A 6-pin mini-DIN connector (CN26) on the card mounting bracket supports single-board computer applications. The card comes with an adapter to convert from the 6-pin mini-DIN connector to a standard DIN connector and to a PS/2 mouse connector.

2.36 CompactFlash Disk (CN27)

The PCA-6770 is equipped with a CompactFlash™ disk socket on the solder side that supports the IDE interface for CompactFlash cards. The on-board CompactFlash socket is designed to prevent incorrect installation. Be sure that the system power is off when installing and removing CompactFlash™ cards.

The CompactFlash card is defaulted as the E drive on your PC system.

2.37 Installing System Memory (SODIMMs)

You can install anywhere from 8 to 256 MB of SDRAM into your PCA-6770 series card. The card provides **two** 144-pin SODIMM sockets. Each socket accepts 8, 16, 32, 64 or 128 MB 3.3 V power level SODIMMs. If only one SODIMM module is installed, it may be installed in either SODIMM socket on the solder side of the PCA-6770 series card.

Note: PCA-6770 card only supports SDRAM SODIMM modules. EDO SODIMM is not supported.

2.37.1 Installing SODIMMs

Note 1: The modules can only fit into a socket one way. Their gold pins must point down into the SODIMM socket. Please refer to the diagram for dimensions.

The procedure for installing SODIMMs appears below. Please follow these steps carefully.

1. Ensure that all power supplies to the system are switched Off.
2. Install the SODIMM card. Install the SODIMM so that its gold pins point down into the SODIMM socket.
3. Slip the SODIMM into the socket at a 45 degree angle and carefully fit the bottom of the card against the connectors.
4. Gently push the SODIMM into a perpendicular position until the clips on the ends of the SODIMM sockets snap into place.
5. Check to ensure that the SODIMM is correctly seated and all connector contacts touch. The SODIMM should not move around in its socket.

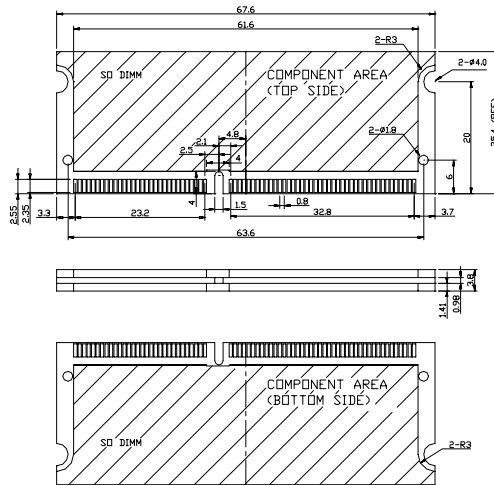

Figure 2-5: Standard SODIMM Dimensions

Note 2: Only use Standard Form SODIMM memory modules (As shown in the dimensions above). Standardized dimensions ensure a proper fit. Check with your Memory supplier about the SODIMM modules you will use.

2.38 CPU installation and upgrading

1. If you are upgrading the CPU, remove the old CPU from the socket. If it is difficult to remove, you may find chip lubricant (designed for pin-grid-array devices, PGAs) and a chip puller helpful. Both are available at electronics hobby supply stores.
2. Plug the new CPU into the empty socket. Follow the instructions that came with the CPU or math coprocessor. If you have no instructions, do the following: Lubricate the CPU pins with lubricant made for PGA devices. This will make the new CPU slide in much more easily, and reduce the chance of damaging it. Next, carefully align the CPU so that it is parallel to the socket and the notch on the corner of the CPU corresponds with the notch on the inside of the socket. Gently slide the CPU in. There will probably be a gap between the CPU and the connector when it is fully seated - do not push too hard!

CHAPTER 3

Award BIOS Setup

This chapter describes how to set the card's BIOS configuration data.

3.1 AWARD BIOS Setup

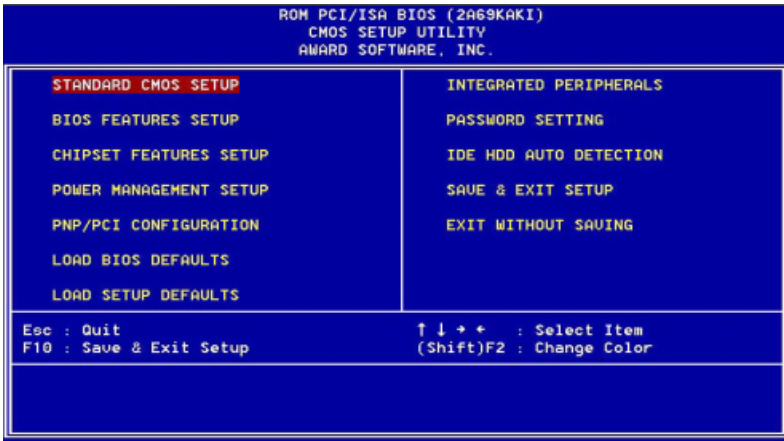

Figure 3-1: Setup program initial screen

Award's BIOS ROM has a built-in Setup program that allows users to modify the basic system configuration. This type of information is stored in battery-backed RAM so that it retains the Setup information when the power is turned off.

3.1.1 Entering setup

Turning on the computer and pressing immediately will allow you to enter Setup.

3.1.2 Standard CMOS setup

Choose the “STANDARD CMOS SETUP” option from the INITIAL SETUP SCREEN Menu, and the screen below is displayed. This standard Setup Menu allows users to configure system components such as date, time, hard disk drive, floppy drive, display, and memory.

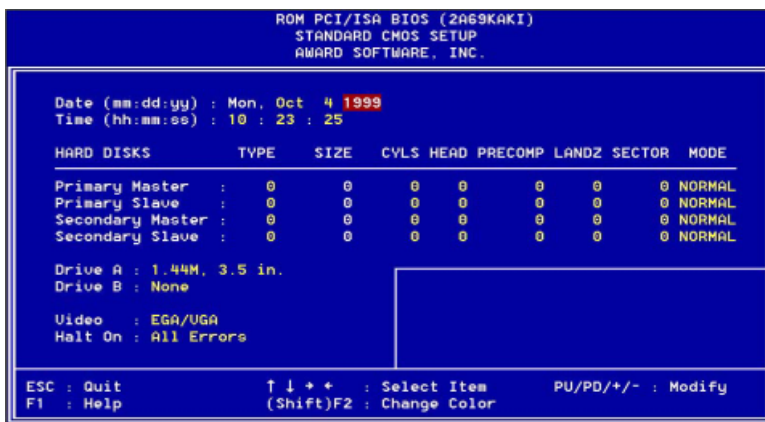

Figure 3-2: CMOS setup screen

3.1.3 BIOS features setup

The “BIOS FEATURES SETUP” screen appears when choosing the BIOS FEATURES SETUP item from the CMOS SETUP UTILITY Menu. It allows the user to configure the PCA-6770 according to his particular requirements.

Below are some major items that are provided in the BIOS FEATURES SETUP screen:

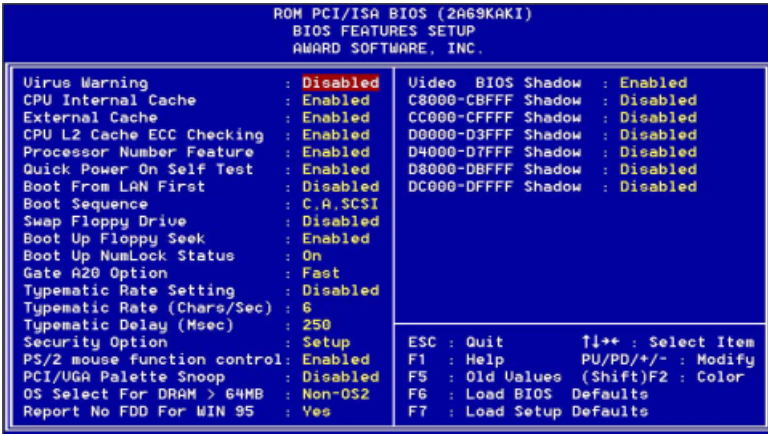

Figure 3-3: BIOS features setup screen

Virus Warning

During and after the system boots up, any attempt to write to the boot sector or partition table of the hard disk drive will halt the system. In this case, a warning message will be displayed. You can run the anti-virus program to locate the problem.

If Virus Warning is Disabled, no warning message will appear if anything attempts to access the boot sector or hard disk partition.

CPU Internal Cache/External Cache

Depending on the CPU/chipset design, these options can speed up memory access when enabled.

Quick Power On Self Test

This option speeds up the Power-On Self Test (POST) conducted as soon as the computer is turned on. When enabled, BIOS shortens or skips some of the items during the test. When disabled, normal POST procedures assumes.

Boot Sequence

This function determines the sequence in which the computer will search the drives for the disk operating system (i.e. DOS). The default value is "C, A".

A,C	System will first search the FDD, then the HDD.
C,A	System will first search the HDD, then the FDD.
C only	System will only search the HDD.
•	•
•	•
•	•

Boot Up Floppy Seek

During POST, BIOS will determine if the floppy disk drive installed is 40 or 80 tracks. 360 KB type is 40 tracks while 720 KB, 1.2 MB, and 1.44 MB are all 80 tracks.

Enabled	BIOS searches the floppy drive to determine if it is 40 or 80 tracks. Note that BIOS cannot differentiate 720 KB, 1.2 MB, and 1.44 MB type drives as they are all 80 tracks.
---------	------------------------------------------------------------------------------------------------------------------------------------------------------------------------------

Disabled	BIOS will not search for the floppy drive type by track number. Note that there will not be any warning message if the drive installed is 360 KB.
----------	---------------------------------------------------------------------------------------------------------------------------------------------------

Boot Up NumLock Status

The default is "On".

On	Keypad boots up to number keys.
----	---------------------------------

Off	Keypad boots up to arrow keys.
-----	--------------------------------

Boot Up System Speed

High	Sets the speed to high
Low	Sets the speed to low

IDE HDD Block Mode

Enabled	Enable IDE HDD Block Mode. BIOS will detect the block size of the HDD and send a block command automatically.
Disabled	Disable IDE HDD Block Mode

Gate A20 option

Normal	The A20 signal is controlled by the keyboard controller or chipset hardware
Fast	Default: Fast. The A20 signal is controlled by Port 92 or chipset specific method.

Typematic Rate Setting

The typematic rate determines the characters per second accepted by the computer. Typematic Rate setting enables or disables the typematic rate.

Typematic Rate (Char/Sec)

BIOS accepts the following input values (character/second) for Typematic Rate: 6, 8, 10, 12, 15, 20, 24, 30.

Typematic Delay (msec)

When holding down a key, the Typematic Delay is the time interval between the appearance of the first and second characters. The input values (msec) for this category are: 250, 500, 750, 1000.

Security Option

This setting determines whether the system will boot if the password is denied, while limiting access to Setup.

System	The system will not boot, and access to Setup will be denied if the correct password is not entered at the prompt.
---------------	--------------------------------------------------------------------------------------------------------------------

Setup	The system will boot, but access to Setup will be denied if the correct password is not entered at the prompt.
--------------	----------------------------------------------------------------------------------------------------------------

Note: To disable security, select PASSWORD SETTING in the main menu. At this point, you will be asked to enter a password. Simply hit the <ENTER> key to disable security. When security is disabled, the system will boot, and you can enter Setup freely.

OS Select for DRAM>64 MB

This setting is under OS/2 system.

Video BIOS Shadow

This determines whether video BIOS will be copied to RAM, which is optional according to the chipset design. When enabled, Video Shadow increases the video speed.

C8000 - CFFFF Shadow/DC000-DFFFF Shadow

These determine whether optional ROM will be copied to RAM in blocks of 16 KB.

Enabled	Optional shadow is enabled
---------	----------------------------

Disabled	Optional shadow is disabled
----------	-----------------------------

3.1.4 CHIPSET features setup

By choosing the “CHIPSET FEATURES SETUP” option from the INITIAL SETUP SCREEN Menu, the screen below is displayed. This sample screen contains the manufacturer’s default values for the PCA-6770.

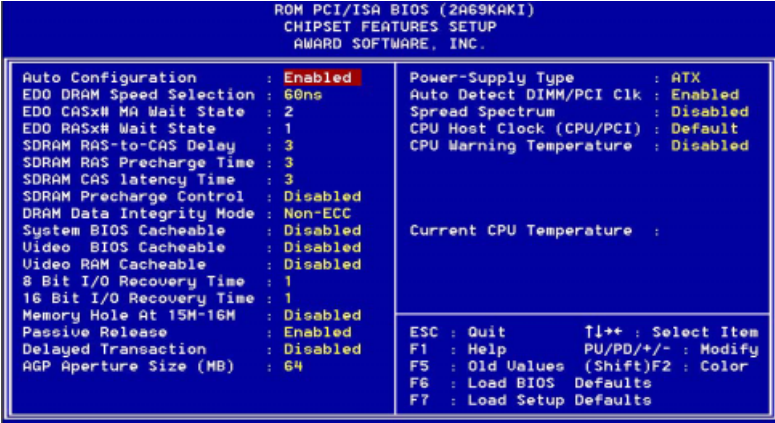

Figure 3-4: CHIPSET features setup screen

3.1.5 Power management setup

The power management setup controls the CPU cards' "green" features. The following screen shows the manufacturer's default.

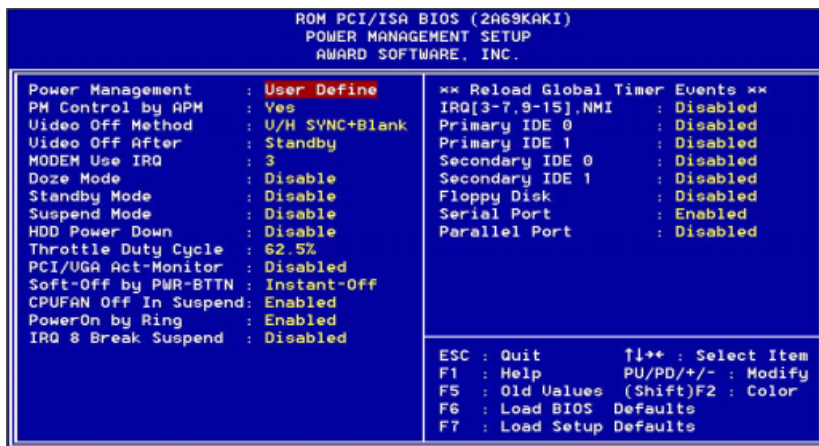

Figure 3-5: Power management setup screen

Power Management

This option allows you to determine if the values in power management are disabled, user-defined, or predefined.

HDD Power Management

You can choose to turn the HDD off after a one of the time interval listed, or when the system is in Suspend mode. If in a power saving mode, any access to the HDD will wake it up.

Note: HDD will not power down if the Power Management option is disabled.

IRQ Activity

IRQ can be set independently. Activity on any enabled IRQ will wake up the system.

3.1.6 PnP PCI configuration setup

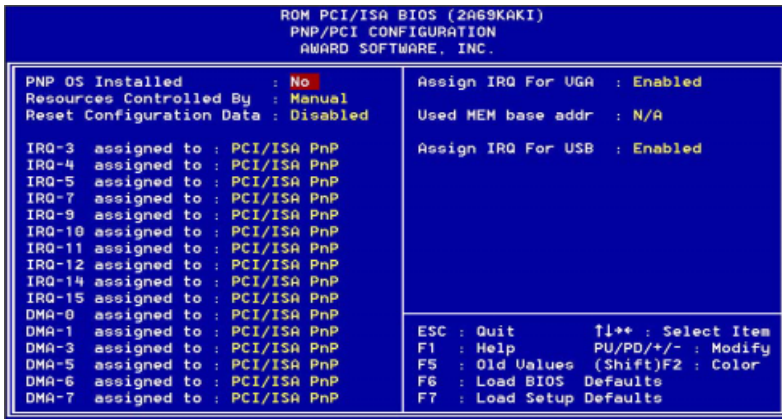

Figure 3-6: PCI configuration screen

3.1.7 Load BIOS defaults

“LOAD BIOS DEFAULTS” indicates the most appropriate values for the system parameters for minimum performance. These default values are loaded automatically if the stored record created by the Setup program becomes corrupted (and therefore unusable).

3.1.8 Load setup defaults

“LOAD SETUP DEFAULTS” loads the values required by the system for maximum performance.

3.1.9 Integrated Peripherals

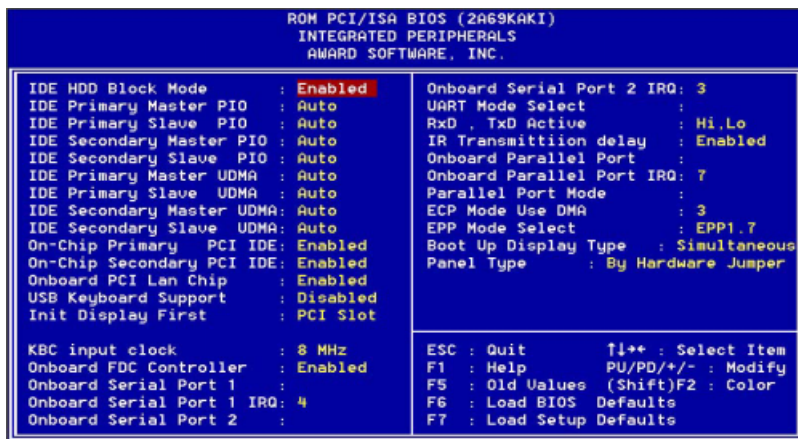

Figure 3-7: Integrated peripherals

Note: If you enable the IDE HDD block mode, the enhanced IDE driver will be enabled.

3.1.10 Password setting

To change, confirm, or disable the password, choose the “PASSWORD SETTING” option from the Setup main menu and press [Enter]. The password can be at most 8 characters long.

Remember, to enable this feature. You must first select the Security Option in the BIOS FEATURES SETUP to be either “Setup” or “System.” Pressing [Enter] again without typing any characters can disable the password setting function.

3.1.11 IDE HDD auto detection

“IDE HDD AUTO DETECTION” automatically self-detect for the correct hard disk type.

3.1.12 Save & exit setup

If you select this and press the [Enter] key, the values entered in the setup utilities will be recorded in the CMOS memory of the chipset. The microprocessor will check this every time you turn your system on and compare this to what it finds as it checks the system. This record is required for the system to operate.

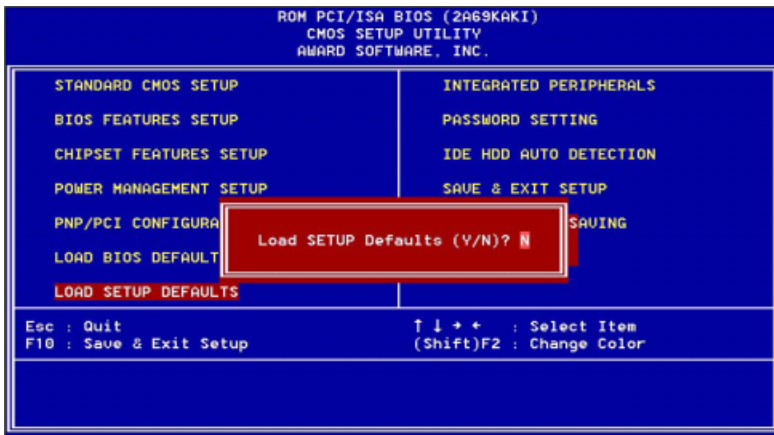

Figure 3-8: Exiting

3.1.13 Exit without saving

Selecting this option and pressing the [Enter] key lets you exit the Setup program without recording any new values or changing old ones.

CHAPTER 4

AGP SVGA Setup

- Introduction
- Installation of SVGA Driver
 - Installation for WINDOWS 3.1
 - Installation for WINDOWS 95
 - Installation for WINDOWS NT
- Further Information

4.1 Introduction

The PCA-6770 has an on-board AGP flat panel/VGA interface. The specifications and features are described as follows:

Chipset

The PCA-6770 uses a C&T69000 chipset for its AGP/SVGA controller. It supports many popular LCD, EL, and gas plasma flat panel displays and conventional analog CRT monitors. The 69000 VGA BIOS supports monochrome LCD, EL, color TFT and STN LCD flat panel displays. In addition, it also supports interlaced and non-interlaced analog monitors (color and monochrome VGA) in high-resolution modes while maintaining complete IBM VGA compatibility. Digital monitors (i.e. MDA, CGA, and EGA) are NOT supported. Multiple frequency (multisync) monitors are handled as if they were analog monitors.

Display memory

With on-die 2 MB display memory, the VGA controller can drive CRT displays or color panel displays with resolutions up to 1024 x 768 at 64 K colors.

Display types

CRT and panel displays can be used simultaneously. The PCA-6770 can be set in one of three configurations: on a CRT, on a flat panel display, or on both simultaneously. The system is initially set to simultaneous display mode. The utility CD ROM includes three *.COM files in the subdirectory
D:\slotpc\6770\Utility.100\ which can be used to configure the display. In order to use these configuration programs, type the file name and path at the DOS prompt.

CT.COM: Enables CRT display only

FP.COM: Enables panel display only

SM.COM: Enables both displays simultaneously

4.2 Installation of SVGA driver

Complete the following steps to install the SVGA driver. Follow the procedures in the flow chart that apply to the operating system that you are using within your PCA-6770.

Important: 1. The following windows illustrations are examples only. You must follow the flow chart instructions and pay attention to the instructions which then appear on your screen.

Note 1: <Enter> means pressing the “Enter” key on the keyboard.

4.2.1 Installation for Windows 3.1

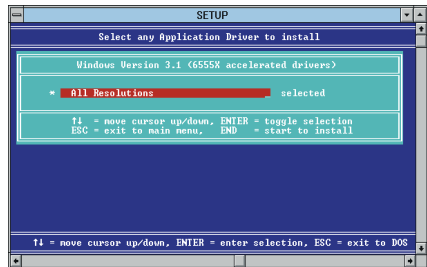
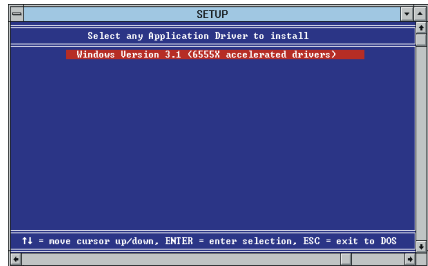
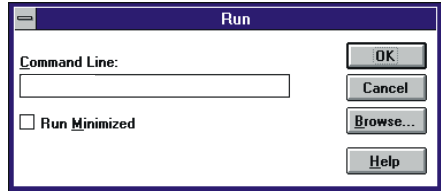
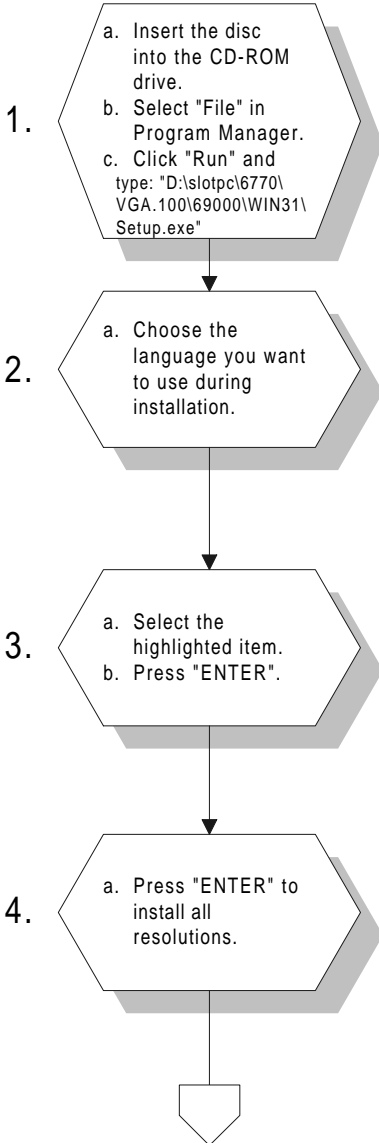

5. a. Type the path of the operating system.

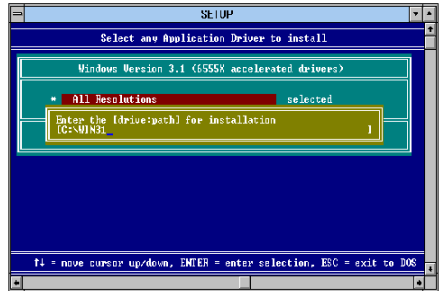

6. a. When installation is completed, reboot the system.
b. You will see the "ChipsCPL" icon in the control panel.

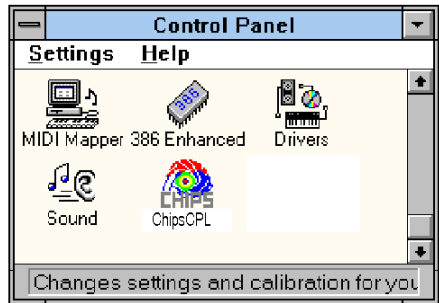

7. a. Double click "ChipsCPL".
b. Adjust screen size, color and refresh rate to your preferences.

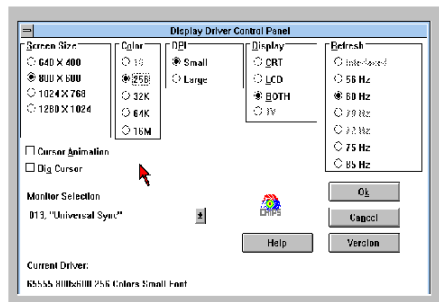

END

4.2.2 Installation for Windows 95/98

1.
 - a. Select "Start", "Settings", "Control Panel", "Display", "Settings".
 - b. Press "Advanced Properties".
2.
 - a. Choose the "Adapter" label.
 - b. Press the "Change..." button.
3.
 - a. Press the "Have Disk" button.
4.
 - a. Insert the disc into the CD-ROM drive.
 - b. Type "D:\slotpc\6770\ VGA.100\69000\ Win95\".
 - c. Press "OK".

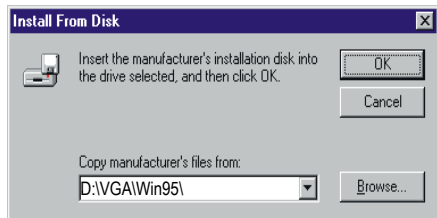
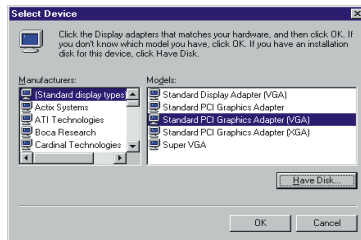
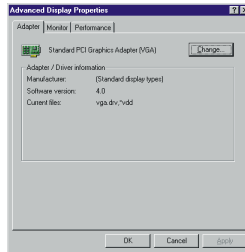
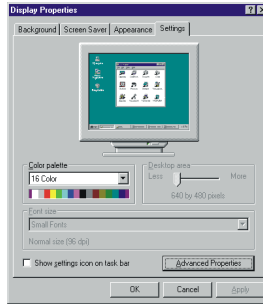

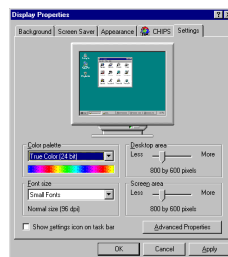
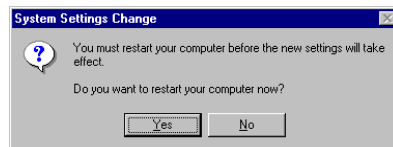
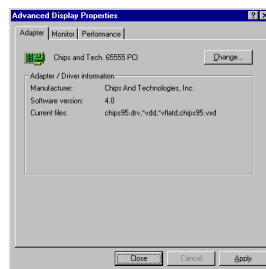
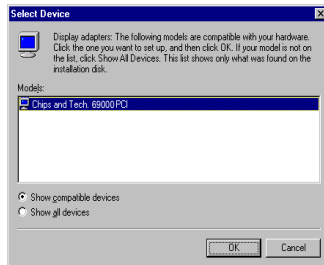
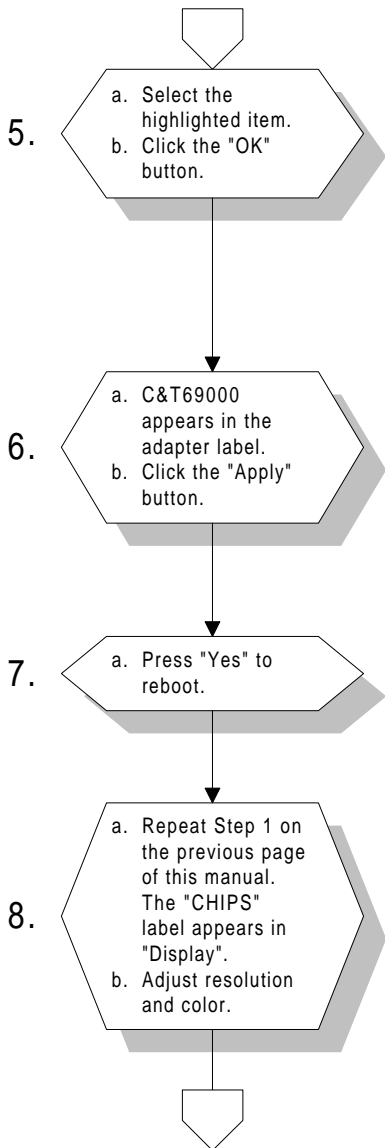

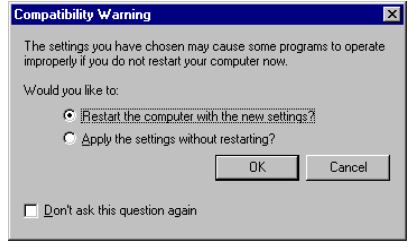
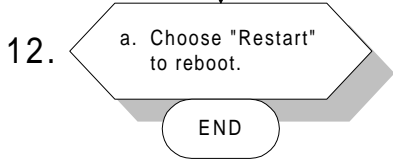
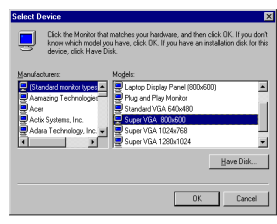
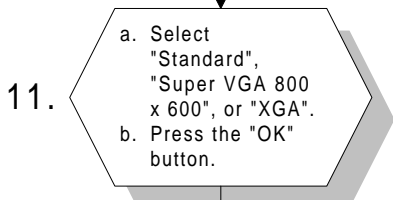
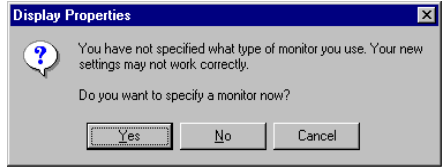
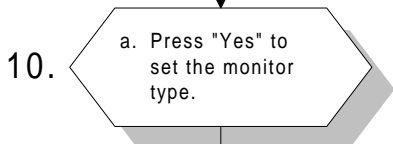
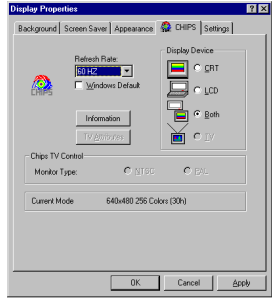
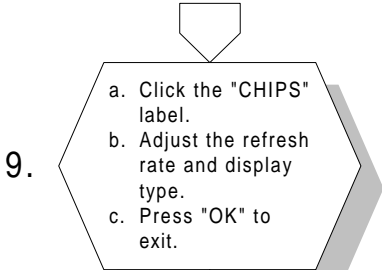

**Note: In step 4 for Windows 98 Installation, the path is:
D:\slotpci6770\VGA.100\69000\WIN98**

4.2.3 Installation for Windows NT

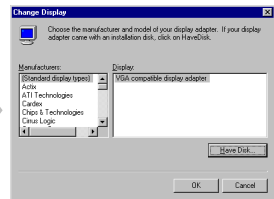
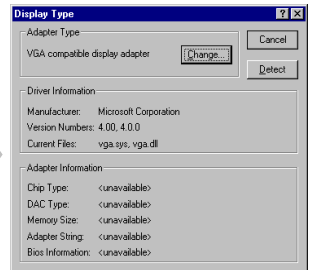
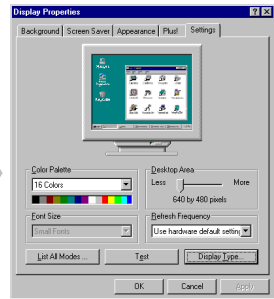
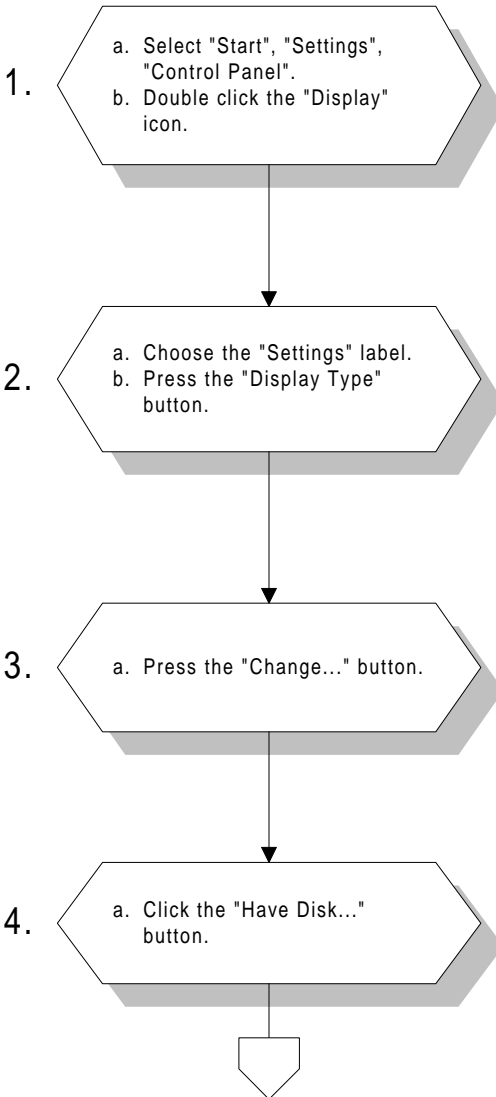

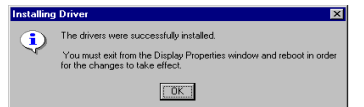
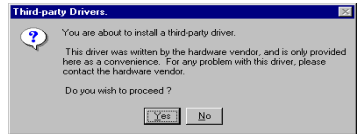
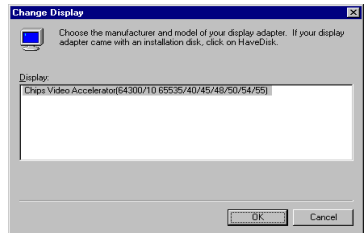
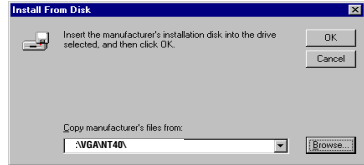
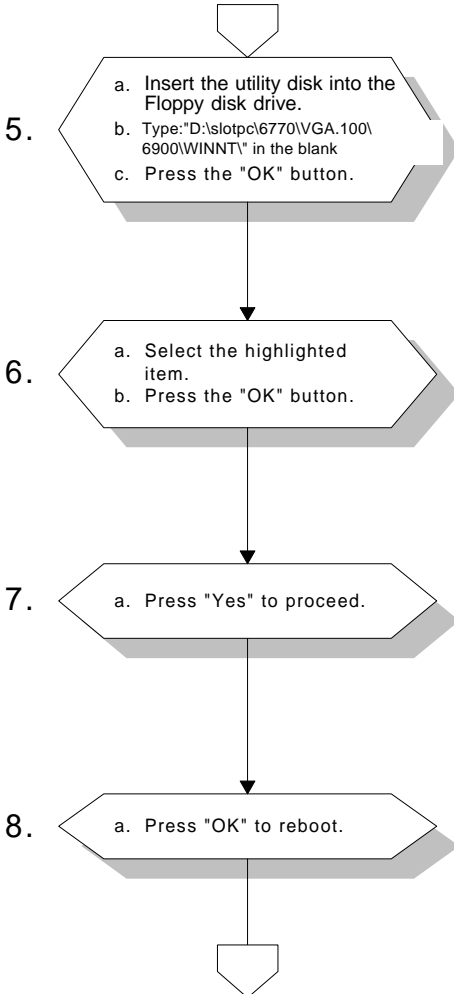

9.

- a. Repeat Step 1 in this manual, to select the "Settings" label.
- b. Adjust resolution and color.
- c. Click "Test" to see the result.
- d. Click "OK" to save the setting.

END

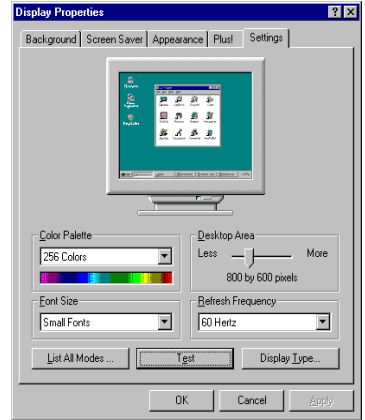

4.3 Further Information

For further information about the AGP/SVGA installation in your PCA-6770 series, including driver updates, troubleshooting guides and FAQ lists, visit the following web resources:

C&T web site: www.chips.com

Advantech web sites: www.advantech.com

support.advantech.com.tw

CHAPTER 5

PCI Bus Ethernet Interface

This chapter provides information on Ethernet configuration.

- Introduction
- Installation of Ethernet driver for
 - MS-DOS
 - Windows 3.1
 - Windows 95
 - Windows 98
 - Windows NT
- Further information

5.1 Introduction

The PCA-6770 is equipped with a high-performance 32-bit Ethernet chipset which is fully compliant with IEEE 802.3 100 Mbps CSMA/CD standards. It is supported by major network operating systems. It is also both 100Base-T and 10Base-T compatible. The medium type can be configured via the **RSET8139.exe** program included on the utility disk.

The Ethernet port provides a standard RJ-45 jack. The network boot feature can be utilized by incorporating the boot ROM image files for the appropriate network operating system. The boot ROM BIOS files are combined with system BIOS, which can be enabled/disabled in the BIOS setup.

5.2 Installation of Ethernet driver

Before installing the Ethernet driver, note the procedures below. You must know which operating system you are using in your PCA-6770, and then refer to the corresponding installation flow chart. Then just follow the steps described in the flow chart. You will quickly and successfully complete the installation, even if you are not familiar with instructions for MS-DOS or WINDOWS.

Note: The windows illustrations in this chapter are examples only. You must follow the flow chart instructions and pay attention to the instructions which then appear on your screen.

5.2.1 Installation for MS-DOS and Windows 3.1

If you want to set up your Ethernet connection under the MS-DOS or Windows 3.1 environment, you should first check your server system model. For example, MS-NT, IBM-LAN server, and so on.

Then choose the correct driver to install in your panel PC.

The installation procedures for various servers can be found on CD-ROM. The file path begins as:

D:\SlotPC\6770\Lan.100\8139B\WZN31

5.2.2 Installation for Windows 95/98

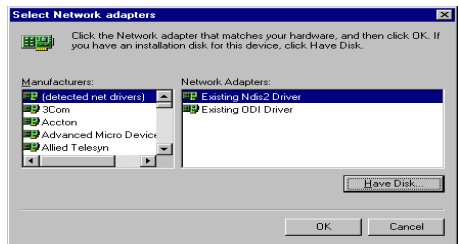
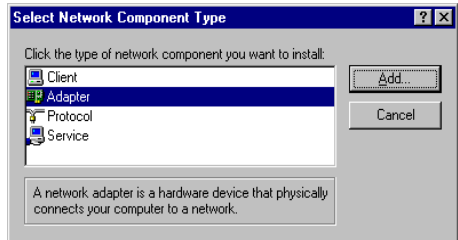
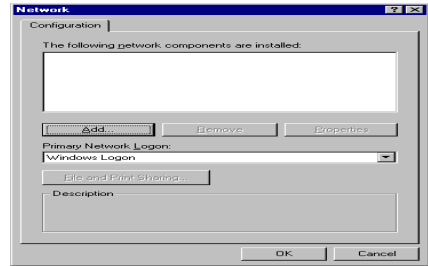
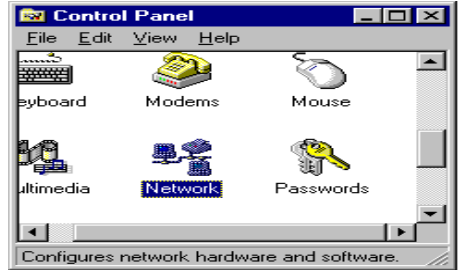
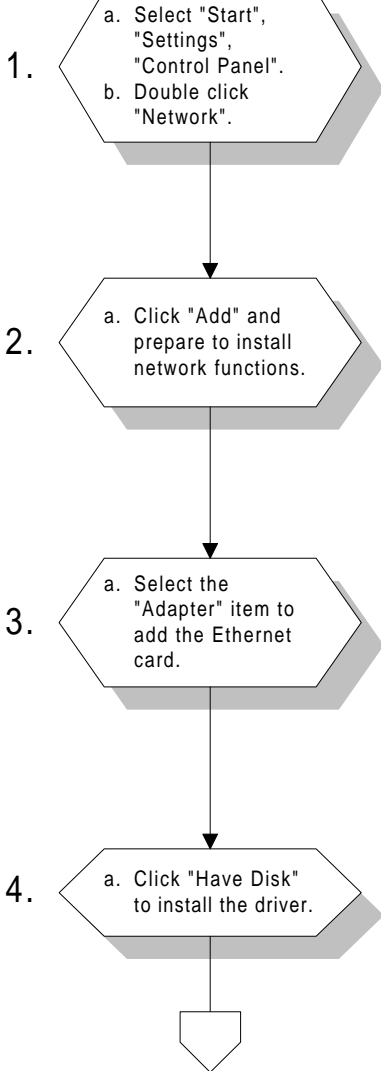

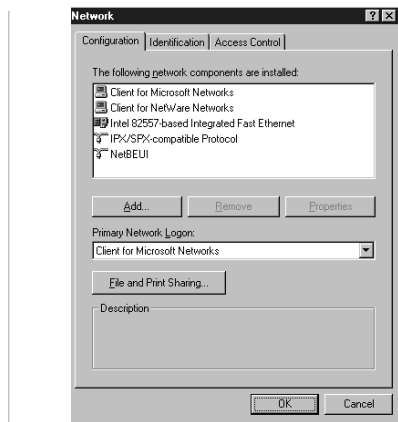
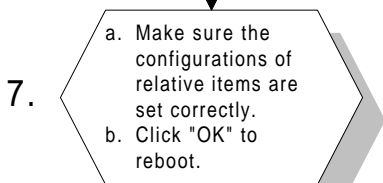
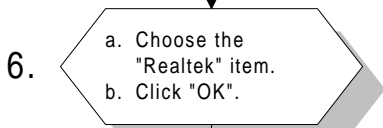
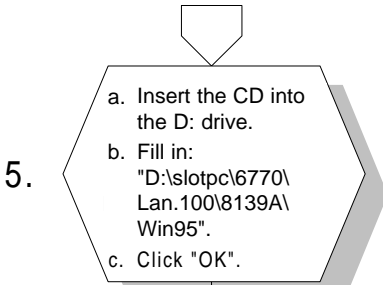

END

Note: The correct file path for Windows 98 is:
D:\slotpc\6770\LAN.100\Win98

5.2.3 Installation for Windows NT

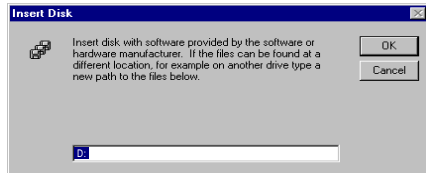
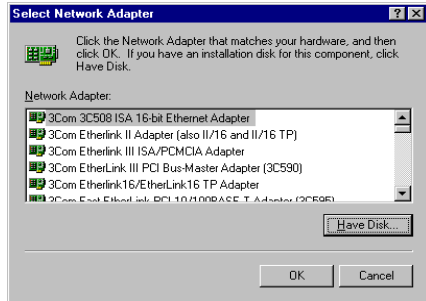
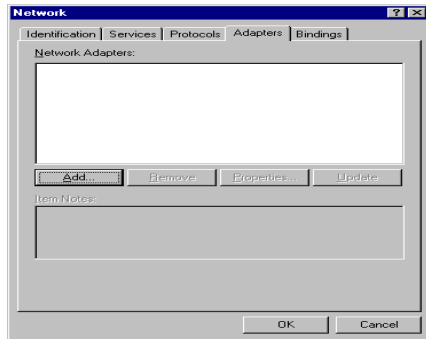
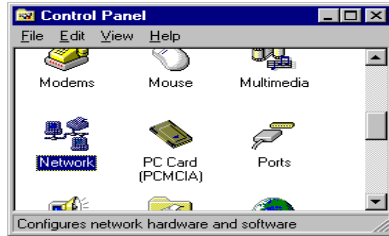
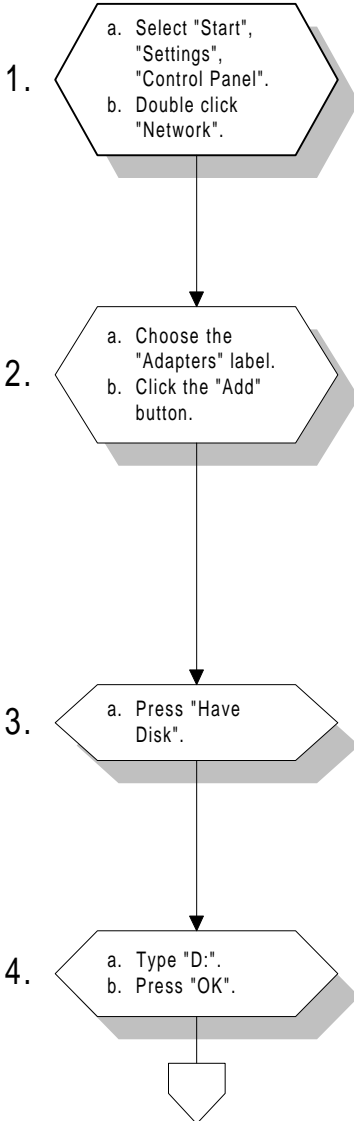

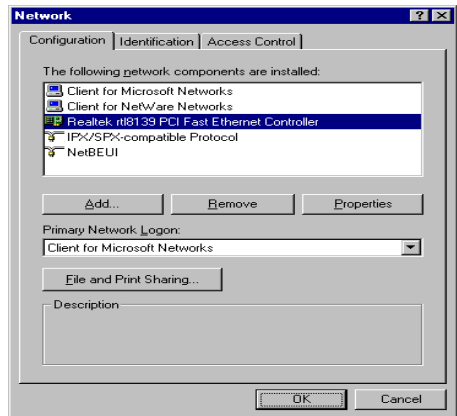
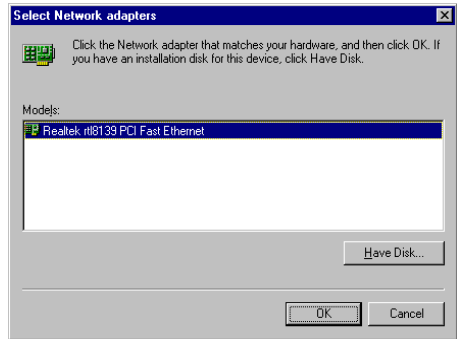
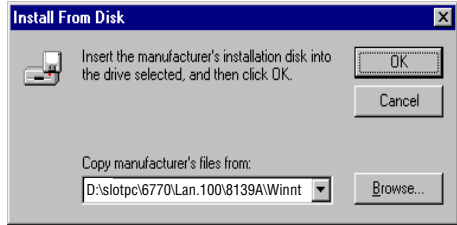
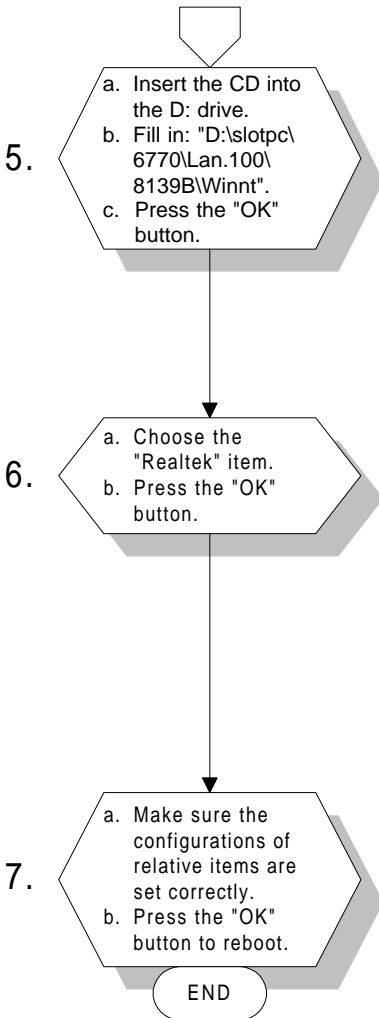

Note: filepath 8139A or 8139B depends on Chip

5.3 Further information

Realtek website: www.realtek.com

Advantech websites: www.advantech.com
www.advantech.com.tw

APPENDIX **A**

Programming the Watchdog Timer

The PCA-6770 is equipped with a watchdog timer that resets the CPU or generates an interrupt if processing comes to a standstill for any reason. This feature ensures system reliability in industrial standalone or unmanned environments.

A.1 Programming the Watchdog Timer

To program the watchdog timer, you must write a program which writes I/O port address 443 (hex). The output data is a value of time interval. The value range is from 01 (hex) to 3E (hex), and the related time interval is 1 sec. to 62 sec.

Data	Time Interval
01	1 sec.
02	2 sec.
03	3 sec.
04	4 sec.
•	•
•	•
•	•
3E	62 sec.

After data entry, your program must refresh the watchdog timer by rewriting the I/O port 443 (hex) while simultaneously setting it. When you want to disable the watchdog timer, your program should read I/O port 443 (hex).

The following example shows how you might program the watchdog timer in BASIC:

```
10      REM  Watchdog timer example program
20      OUT &H443, data REM  Start and restart the watchdog
30      GOSUB 1000 REM  Your application task #1,
40      OUT &H443, data REM  Reset the timer
50      GOSUB 2000 REM  Your application task #2,
60      OUT &H443, data REM  Reset the timer
70      X=INP (&H443) REM, Disable the watchdog timer
80      END

1000    REM  Subroutine #1, your application task
.      .
.      .
.      .
1070    RETURN
2000    REM  Subroutine #2, your application task
.      .
.      .
.      .
2090    RETURN
```

APPENDIX **B**

Installing PC/104 Modules

This appendix gives instructions for installing PC/104 modules.

B.1 Installing PC/104 modules

The PCA-6770 PC/104 connectors give you the flexibility to attach PC/104 modules.

Installing these modules on the PCA-6770 is quick and simple. The following steps show how to mount the PC/104 modules:

1. Remove the PCA-6770 from your system paying particular attention to the safety instructions already mentioned above.
2. Make any jumper or link changes required to the CPU card now. Once the PC/104 module is mounted you may have difficulty in accessing these.
3. Normal PC/104 modules have male connectors and mount directly onto the main card. (Refer to the diagram on the following page.)
4. Mount the PC/104 module onto the CPU card by pressing the module firmly but carefully onto the mounting connectors.
5. Secure the PC/104 module onto the CPU card using the four mounting spacers and screws.

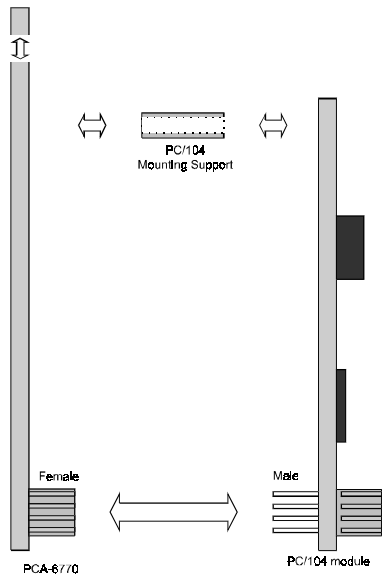

Figure B-1: PC/104 module mounting diagram

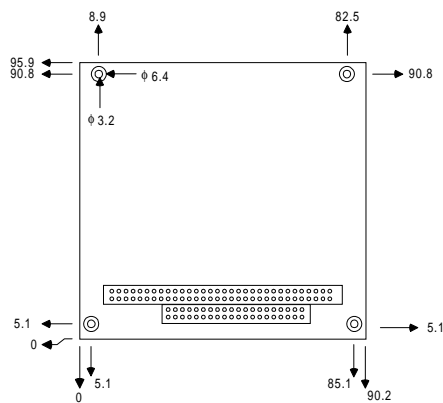

Figure B-2: PC/104 module dimensions (mm) (± 0.1)

Table B-1: PCA-6770 PC/104 connectors (CN12)

Pin Number	Signal (CN12)		Signal (CN13)	
	Row A	Row B	Row C	Row D
0	—	—	0 V	0 V
1	IOCHCHK*	0 V	SBHE*	MEMCS16*
2	SD7	RESETDRV	LA23	IOCS16*
3	SD6	+5 V	LA22	IRQ10
4	SD5	IRQ9	LA21	IRQ11
5	SD4	-5 V	LA20	IRQ12
6	SD3	DRQ2	LA19	IRQ15
7	SD2	-12 V	LA18	IRQ14
8	SD1	ENDXFR*	LA17	DACK0*
9	SD0	+12 V	MEMR*	DRQ0
10	IOCHRDY	N/C	MEMW*	DACK5*
11	AEN	SMEMW*	SD8	DRQ5
12	SA19	SMEMR*	SD9	DACK6*
13	SA18	IOW*	SD10	DRQ6
14	SA17	IOR*	SD11	DACK7*
15	SA16	DACK3*	SD12	DRQ7
16	SA15	DRQ3	SD13	+5 V
17	SA14	DACK1*	SD14	MASTER*
18	SA13	DRQ1	SD15	0 V
19	SA12	REFRESH*	KEY	0 V
20	SA11	SYSCLK	—	—
21	SA10	IRQ7	—	—
22	SA9	IRQ6	—	—
23	SA8	IRQ5	—	—
24	SA7	IRQ4	—	—
25	SA6	IRQ3	—	—
26	SA5	DACK2*	—	—
27	SA4	TC	—	—
28	SA3	BALE	—	—
29	SA2	+5 V	—	—
30	SA1	OSC	—	—
31	SA0	0 V	—	—
32	0 V	0 V	—	—

*active low

APPENDIX
C

Pin Assignments

This appendix contains information of a detailed or specialized nature. It includes:

- CRT display connector
- LCD display/inverter connector
- RS-232/422/485 serial port connector
- Keyboard and mouse connector
- External keyboard connector
- Main power connectors (AT/ATX)
- IDE connector
- RS-232 serial port connector
- Ethernet RJ-45 connector
- Floppy connector
- Parallel connector
- IR connector
- HDD LED connector
- CompactFlash card connector

C.1 IDE Hard Drive Connector (CN1)

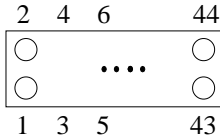

Table C-8: IDE hard drive connector

Pin	Signal	Pin	Signal
1	IDE RESET*	2	GND
3	DATA 7	4	DATA 8
5	DATA 6	6	DATA 9
7	DATA 5	8	DATA 10
9	DATA 4	10	DATA 11
11	DATA 3	12	DATA 12
13	DATA 2	14	DATA 13
15	DATA 1	16	DATA 14
17	DATA 0	18	DATA 15
19	SIGNAL GND	20	N/C
21	N/C	22	GND
23	IO WRITE	24	GND
25	IO READ	26	GND
27	IO CHANNEL READY	28	N/C
29	HDACKO*	30	GND
31	IRQ14	32	IOCS16
33	ADDR 1	34	N/C
35	ADDR 0	36	ADDR 2
37	HARD DISK SELECT 0*	38	HARD DISK SELECT 1*
39	IDE ACTIVE*	40	GND
41	5 V	42	5 V
43	GND	44	NC

* low active

C.2 Parallel Port Connector (CN2)

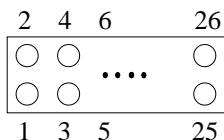

Table C-2: Parallel port connector

Pin	Signal
1	* STROBE
2	* AUTOFD
3	D0
4	ERR
5	D1
6	* INIT
7	D2
8	* SLCTINI
9	D3
10	GND
11	D4
12	GND
13	D5
14	GND
15	D6
16	GND
17	D7
18	GND
19	* ACK
20	GND
21	BUSY
22	GND
23	PE
24	GND
25	SLCT
26	GND

* low active

C.3 ATX Power Connector (CN3)

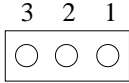

Table C-10: ATX power connector

Pin	Signal
1	5 V SB
2	N/C
3	PS_ON

C.4 AT Power Connector (CN4)

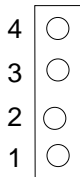

Table C-23: AT power connector

Pin	Signal
1	+12 V
2	GND
3	GND
4	+5 V

C.5 LCD Power Inverter (CN5)

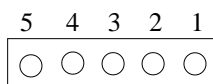

Table C-22: LCD power inverter

Pin	Signal
1	+12 V
2	GND
3	ENABKL
4	VBR
5	+ 5 V

C.6 Floppy Drive Connector (CN6)

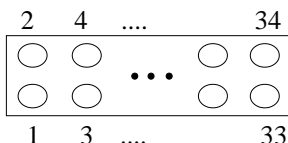

Table C-9: Floppy drive connector

Pin	Signal	Pin	Signal
1	GND	2	DENSITY SELECT*
3	GND	4	N/C
5	GND	6	DS1*
7	GND	8	INDEX*
9	GND	10	MOTOR 0*
11	GND	12	DRIVE SELECT 1*
13	GND	14	DRIVE SELECT 0*
15	GND	16	MOTOR 1*
17	GND	18	DIRECTION*
19	GND	20	STEP*
21	GND	22	WRITE DATA*
23	GND	24	WRITE GATE*
25	GND	26	TRACK 0*
27	GND	28	WRITE PROTECT*
29	GND	30	READ DATA*
31	GND	32	HEAD SELECT*
33	GND	34	DISK CHANGE*

* low active

C.7 Reset Switch Connector (CN7)



Table C-11: Reset switch connector

Pin	Signal
1	MR_RESET
2	GND

C.8 IR Connector (CN8)

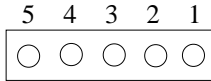

Table C-4: IR connector

Pin	Signal
1	+5 V
2	N/C
3	IR_RX
4	GND
5	IR_TX

C.9 Keyboard Lock Connector (CN9)

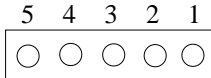

Table C-6: Keyboard lock connector

Pin	Signal
1	+5 V
2	N/C
3	GND
4	KBLOCK
5	GND

C.10 IDE LED Connector (CN10)



Table C-3: HDD LED connector

Pin	Signal
1	IDE LED -
2	IDE LED +

C.11 ATX Power Switch (CN11)



Table C-5: ATX power switch

Pin	Signal
1	Standby 5 V
2	Power ON

C.12 External Speaker Connector (CN12)

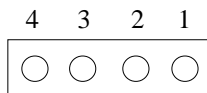

Table C-7: External speaker connector

Pin	Signal
1	+ 5 V
2	N/C
3	Internal speaker
4	External speaker

C.13 USB1/USB2 Connector (CN13)

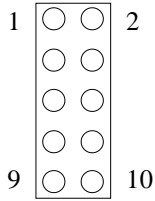

Table C-1: USB1/USB2 connector

	USB1		USB2
1	+5 V	2	+5 V
3	UV-	4	UV-
5	UV+	6	UV+
7	GND	8	GND
9	Chassis GND	10	N/C

C.14 Flat panel display Connector (CN14)

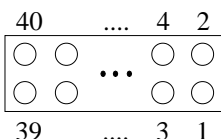

Table C-5: 24-bit LCD display connector

Pin	Signal	Pin	Signal
1	VDDSAFE5	2	VDDSAFE5
3	GND	4	GND
5	VDDSAFE3	6	VDDSAFE3
7	Vcon	8	GND
9	P0	10	P1
11	P2	12	P3
13	P4	14	P5
15	P6	16	P7
17	P8	18	P9
19	P10	20	P11
21	P12	22	P13
23	P14	24	P15
25	P16	26	P17
27	P18	28	P19
29	P20	30	P21
31	P22	32	P23
33	GND	34	GND
35	SHIFT CLOCK	36	FILM
37	M	38	LP
39	DOTCLK	40	ENAVEE

Note: The model number of the CN18 socket is DF13A-40DP-1.25V (Hirose Electric Co., Ltd.)

C.15 Ext flat panel display connector (CN15)

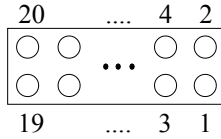

Table C-19: 36-bit LCD display connector

Pin	Signal	Pin	Signal
1	GND	2	GND
3	P24	4	P25
5	P26	6	P27
7	P28	8	P29
9	P30	10	P31
11	P32	12	P33
13	P34	14	P35
15	GND	16	GND
17	N/C	18	N/C
19	N/C	20	N/C

Note: The model number of the CN19 socket is DF13A-20DP-1.25V (Hirose Electric Co., Ltd.)

C.16 CRT Display Connector (CN16)

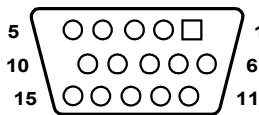

Table C-12: CRT display connector

Pin	Signal	Pin	Signal
1	RED	9	Vcc
2	GREEN	10	GND
3	BLUE	11	N/C
4	N/C	12	DDC-DAT
5	GND	13	H-SYNC
6	GND	14	V-SYNC
7	GND	15	DDC-CLK
8	GND		

C.19 CPU Fan Power Connector (CN19)

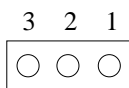

Table C-13: CPU fan power connector

Pin	Signal
1	NC
2	+12 V
3	GND

C.20 COM2 RS-422/485 Serial Port (CN20)

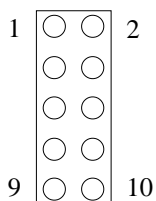

Table C-16: COM2 RS-232/422/485 serial port

Pin	RS-422 port	RS-485 port
1	TXD-	DATA-
2	N/C	N/C
3	TXD+	DATA+
4	N/C	N/C
5	RXD+	N/C
6	N/C	N/C
7	RXD-	N/C
8	N/C	N/C
9	GND	GND
10	N/C	N/C

C.21 COM2 RS-232 Serial Port (CN21)

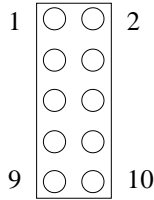

Table C-17: COM2 RS-232 serial port

Pin	RS-232 port	Pin	RS-232 port
1	DCD	6	CTS
2	DSR	7	DTR
3	RxD	8	RI
4	RTS	9	GND
5	TxD	10	N/C

C.22 COM1 RS-232 Serial Port (CN22)

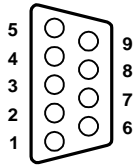

Table C-15: COM1 RS-232 serial port

Pin	Signal
1	DCD
2	RxD
3	TxD
4	DTR
5	GND
6	DSR
7	RTS
8	CTS
9	RI

C.25 External Keyboard Connector (CN25)

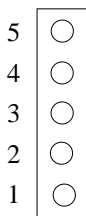

Table C-21: External keyboard connector

Pin	Signal
1	CLK
2	DATA
3	NC
4	GND
5	+ 5 V

C.26 Keyboard and Mouse Connector (CN26)

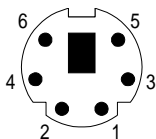

Table C-20: Keyboard and mouse connector

Pin	Signal
1	KB DATA
2	MS DATA
3	GND
4	+5 V
5	KB CLOCK
6	MS CLOCK

C.27 CompactFlash Card Connector (CN27)

Table C-24: CompactFlash card connector

Pin	Signal	Pin	Signal
1	GND	2	D03
3	D04	4	D05
5	D06	6	D07
7	* CS0	8	A10 ²
9	* ATA SEL	10	A09 ²
11	A08 ²	12	A07 ²
13	+5 V	14	A06 ²
15	A05 ²	16	A04 ²
17	A03 ²	18	A02
19	A01	20	A00
21	D00	22	D01
23	D02	24	* IOCS16
25	* CD2	26	* CD1
27	D11 ¹	28	D12 ¹
29	D13 ¹	30	D14 ¹
31	D15 ¹	32	* CS1 ¹
33	* VS1	34	* IORD
35	* IOWR	36	* WE ³
37	INTRQ	38	+5 V
39	* CSEL	40	* VS2
41	* RESER	42	IORDY
43	* INPACK	44	* REG ³
45	* DASP	46	* PDIAG
47	D08 ¹	48	D09 ¹
49	D10	50	GND

* low active

System Assignments

This appendix contains information of a detailed or specialized nature. It includes:

- System I/O ports
- DMA channel assignments
- Interrupt assignments
- 1st MB memory map

D.1 System I/O Ports

Table D-1: System I/O ports

Addr. range (Hex)	Device
000-01F	DMA controller
020-021	Interrupt controller 1, master
022-023	Chipset address
040-05F	8254 timer
060-06F	8042 (keyboard controller)
070-07F	Real-time clock, non-maskable interrupt (NMI) mask
080-09F	DMA page register
0A0-0BF	Interrupt controller 2
0C0-0DF	DMA controller
0F0	Clear math co-processor
0F1	Reset math co-processor
0F8-0FF	Math co-processor
1F0-1F8	Fixed disk
200-207	Game I/O
278-27F	Parallel printer port 2 (LPT 3)
2F8-2FF	Serial port 2
300-31F	Prototype card
360-36F	Reserved
378-37F	Parallel printer port 1 (LPT 2)
380-38F	SDLC, bisynchronous 2
3A0-3AF	Bisynchronous 1
3B0-3BF	Monochrome display and printer adapter (LPT1)
3C0-3CF	Reserved
3D0-3DF	Color/graphics monitor adapter
3F0-3F7	Diskette controller
3F8-3FF	Serial port 1

* PNP audio I/O map range from 220 ~ 250H (16 bytes)
MPU-401 select from 300 ~ 330H (2 bytes)

D.2 DMA Channel Assignments

Table D-2: DMA channel assignments

Channel	Function
0	Available
1	Available
2	Floppy disk (8-bit transfer)
3	Available
4	Cascade for DMA controller 1
5	Available
6	Available
7	Available

* Audio DMA select 0, 1 or 3

D.3 Interrupt Assignments

Table D-3: Interrupt assignments

Interrupt#	Interrupt source
IRQ 0	Interval timer
IRQ 1	Keyboard
IRQ 2	Interrupt from controller 2 (cascade)
IRQ 8	Real-time clock
IRQ 9	Cascaded to INT 0A (IRQ 2)
IRQ 10	Available
IRQ 11	Watchdog Timer
IRQ 12	PS/2 mouse (non-releasable)
IRQ 13	INT from co-processor
IRQ 14	Fixed disk controller (primary)
IRQ 15	Fixed disk controller (secondary)
IRQ 3	Serial communication port 2
IRQ 4	Serial communication port 1
IRQ 5	Parallel port 2
IRQ 6	Diskette controller (FDC)
IRQ 7	Parallel port 1 (print port)

* PNP audio IRQ select: 5, 7, 9 or 10

* Ethernet function is auto-sensing

D.4 1st MB Memory Map

Table D-4:1st MB memory map

Addr. range (Hex)	Device
F000h - FFFFh	System ROM
C800h - EFFFh	Expansion ROM
C000h - C7FFh	System ROM
B800h - BFFFh	CGA/EGA/VGA text
B000h - B7FFh	Unused
A000h - AFFFh	EGA/VGA graphics
0000h - 9FFFh	Base memory