

FCC Information and Copyright

This equipment has been tested and found to comply with the limits of a Class B digital device, pursuant to Part 15 of the FCC Rules. These limits are designed to provide reasonable protection against harmful interference in a residential installation. This equipment generates, uses and can radiate radio frequency energy and, if not installed and used in accordance with the instructions, may cause harmful interference to radio communications. There is no guarantee that interference will not occur in a particular installation.

The vendor makes no representations or warranties with respect to the contents here and specially disclaims any implied warranties of merchantability or fitness for any purpose. Further the vendor reserves the right to revise this publication and to make changes to the contents here without obligation to notify any party beforehand.

Duplication of this publication, in part or in whole, is not allowed without first obtaining the vendor's approval in writing.

The content of this user's manual is subject to be changed without notice and we will not be responsible for any mistakes found in this user's manual. All the brand and product names are trademarks of their respective companies.

Table of Contents

Chapter 1: Introduction	1
1.1 Before You Start.....	1
1.2 Package Checklist.....	1
1.3 Motherboard Features.....	2
1.4 Rear Panel Connectors (for Ver 5.x).....	4
1.5 Rear Panel Connectors (for Ver 6.x).....	4
1.6 Motherboard Layout (for Ver 5.x).....	5
1.7 Motherboard Layout (for Ver 6.x).....	6
Chapter 2: Hardware Installation	7
2.1 Installing Central Processing Unit (CPU).....	7
2.2 FAN Headers.....	9
2.3 Installing System Memory.....	10
2.4 Connectors and Slots.....	12
Chapter 3: Headers & Jumpers Setup	14
3.1 How to Setup Jumpers.....	14
3.2 Detail Settings.....	14
Chapter 4: Useful Help	20
4.1 Driver Installation Note	20
4.2 Award BIOS Beep Code.....	21
4.3 Extra Information.....	21
4.4 Troubleshooting.....	23
Chapter 5: WarpSpeeder™	24
5.1 Introduction.....	24
5.2 System Requirement.....	24
5.3 Installation.....	25
5.4 WarpSpeeder™.....	26
Appendices: SPEC In Other Language	32
German.....	32
France.....	34
Italian.....	36
Spanish.....	38
Portuguese.....	40
Polish.....	42
RUSSIAN.....	44
ARABIC.....	46
JAPANESE.....	48

CHAPTER 1: INTRODUCTION

1.1 BEFORE YOU START

Thank you for choosing our product. Before you start installing the motherboard, please make sure you follow the instructions below:

- Prepare a dry and stable working environment with sufficient lighting.
- Always disconnect the computer from power outlet before operation.
- Before you take the motherboard out from anti-static bag, ground yourself properly by touching any safely grounded appliance, or use grounded wrist strap to remove the static charge.
- Avoid touching the components on motherboard or the rear side of the board unless necessary. Hold the board on the edge, do not try to bend or flex the board.
- Do not leave any unfastened small parts inside the case after installation. Loose parts will cause short circuits which may damage the equipment.
- Keep the computer from dangerous area, such as heat source, humid air and water.

1.2 PACKAGE CHECKLIST

- ✦ FDD Cable X 1
- ✦ HDD Cable X 1
- ✦ Rear I/O Panel for ATX Case X 1
- ✦ User's Manual X 1
- ✦ Fully Setup Driver CD X 1
- ✦ Serial ATA Cable X 1 (optional)
- ✦ Serial ATA Power Cable X 1 (optional)
- ✦ USB 2.0 Cable X1 (optional)
- ✦ S/PDIF out Cable X 1 (optional)

1.3 MOTHERBOARD FEATURES

	<i>Ver 5.x</i>	<i>Ver 6.x</i>
CPU	LGA 775 Intel Core2Duo / Core2Quad / Pentium D / Pentium 4 / Celeron D processor up to 3.8 GHz Supports Hyper-Threading/ Execute Disable Bit/ Enhanced Intel SpeedStep® / Intel Architecture-64 / Extended Memory 64 Technology / Virtualization Technology	LGA 775 Intel Core2Duo / Core2Quad / Pentium D / Pentium 4 / Celeron D processor up to 3.8 GHz Supports Hyper-Threading/ Execute Disable Bit/ Enhanced Intel SpeedStep® / Intel Architecture-64 / Extended Memory 64 Technology / Virtualization Technology
FSB	533 / 800 / 1066 MHz	533 / 800 / 1066 MHz
Chipset	Intel P965 Intel ICH8	Intel P965 Intel ICH8
Super I/O	ITE 8712F Provides the most commonly used legacy Super I/O functionality. Low Pin Count Interface Environment Control initiatives, H/W Monitor Fan Speed Controller ITE's "Smart Guardian" function	ITE 8712F Provides the most commonly used legacy Super I/O functionality. Low Pin Count Interface Environment Control initiatives, H/W Monitor Fan Speed Controller ITE's "Smart Guardian" function
Main Memory	DIMM Slots x 4 Each DIMM supports 256MB / 512MB / 1GB / 2GB DDR2 Max Memory Capacity 8GB Dual Channel Mode DDR2 memory module Supports DDR2 533 / 667 / 800 Registered DIMM and ECC DIMM is not supported	DIMM Slots x 4 Each DIMM supports 256MB / 512MB / 1GB / 2GB DDR2 Max Memory Capacity 8GB Dual Channel Mode DDR2 memory module Supports DDR2 533 / 667 / 800 Registered DIMM and ECC DIMM is not supported
IDE	VIA VT6410 Ultra DMA 33 / 66 / 100 / 133 Bus Master Mode supports PIO Mode 0~4,	VIA VT6410 Ultra DMA 33 / 66 / 100 / 133 Bus Master Mode supports PIO Mode 0~4,
SATA 2	Integrated Serial ATA Controller Data transfer rates up to 3.0 Gb/s. SATA Version 2.0 specification compliant.	Integrated Serial ATA Controller Data transfer rates up to 3.0 Gb/s. SATA Version 2.0 specification compliant.
LAN	Realtek RTL 8110SC 10 / 100 Mb/s and 1Gb/s auto negotiation Half / Full duplex capability	Realtek RTL 8110SC 10 / 100 Mb/s and 1Gb/s auto negotiation Half / Full duplex capability

	<i>Ver 5.x</i>		<i>Ver 6.x</i>	
Sound Codec	ALC888 7.1 channels audio out Intel High Definition Audio		ALC861VD 5.1 channels audio out Intel High Definition Audio	
Slots	PCI slot	x3	PCI slot	x3
	PCI Express x 16 slot	x1	PCI Express x 16 slot	x1
	PCI Express x 4 slot	x1	PCI Express x 4 slot	x1
	PCI Express x 1 slot	x1	PCI Express x 1 slot	x1
On Board Connector	Floppy connector	x1	Floppy connector	x1
	Printer Port Connector	x1	Printer Port Connector	x1
	IDE Connector	x1	IDE Connector	x1
	SATA Connector	x4	SATA Connector	x4
	Front Panel Connector	x1	Front Panel Connector	x1
	Front Audio Connector	x1	Front Audio Connector	x1
	CD-in Connector(optional)	x1	CD-in Connector(optional)	x1
	S/PDIF out connector	x1	S/PDIF out connector	x1
	S/PDIF in connector(optional)	x1	S/PDIF in connector(optional)	x1
	CPU Fan header	x1	CPU Fan header	x1
	System Fan header	x2	System Fan header	x2
	Clear CMOS header	x1	Clear CMOS header	x1
	USB connector	x2	USB connector	x2
	Power Connector (24pin)	x1	Power Connector (24pin)	x1
	Power Connector (4pin)	x1	Power Connector (4pin)	x1
Back Panel I/O	PS/2 Keyboard	x1	PS/2 Keyboard	x1
	PS/2 Mouse	x1	PS/2 Mouse	x1
	Serial Port	x1	Serial Port	x1
	LAN port	x1	LAN port	x1
	USB Port	x6	USB Port	x6
	Audio Jack	x6	Audio Jack	x3
Board Size	220 (W) x 305 (L) mm ATX form Factor		220 (W) x 305 (L) mm ATX form Factor	
OS Support	Windows 2000 / XP / VISTA Biostar Reserves the right to add or remove support for any OS with or without notice.		Windows 2000 / XP / VISTA Biostar Reserves the right to add or remove support for any OS with or without notice.	

1.4 REAR PANEL CONNECTORS (FOR VER 5.X)

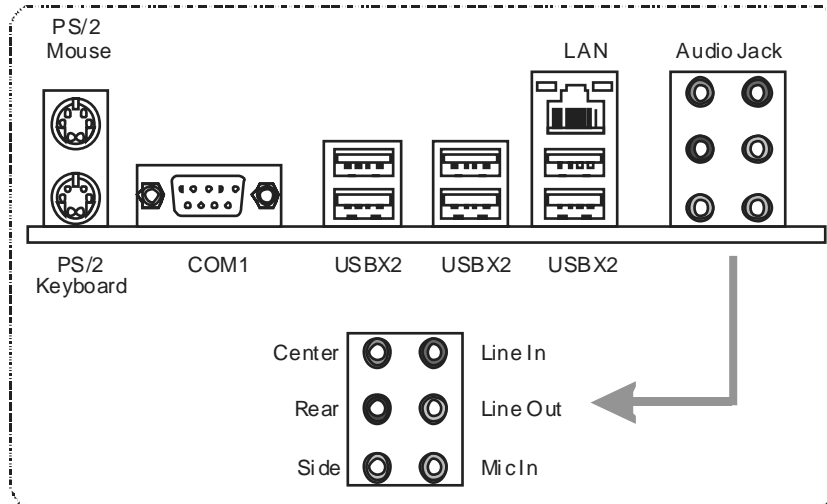

1.5 REAR PANEL CONNECTORS (FOR VER 6.X)

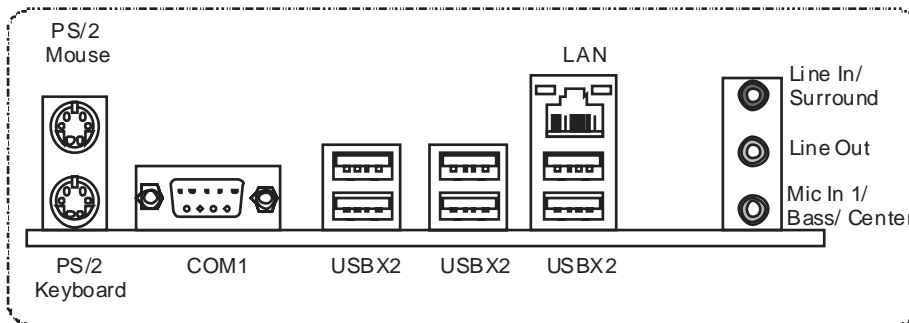

Since the audio chip supports Intel High Definition Audio Specification, the function of each audio jack can be defined by software. The input / output function of each audio jack listed above represents the default setting. However, when connecting external microphone to the audio port, please use the Line In (blue) and Mic In (Pink) audio jack.

1.6 MOTHERBOARD LAYOUT (FOR VER 5.x)

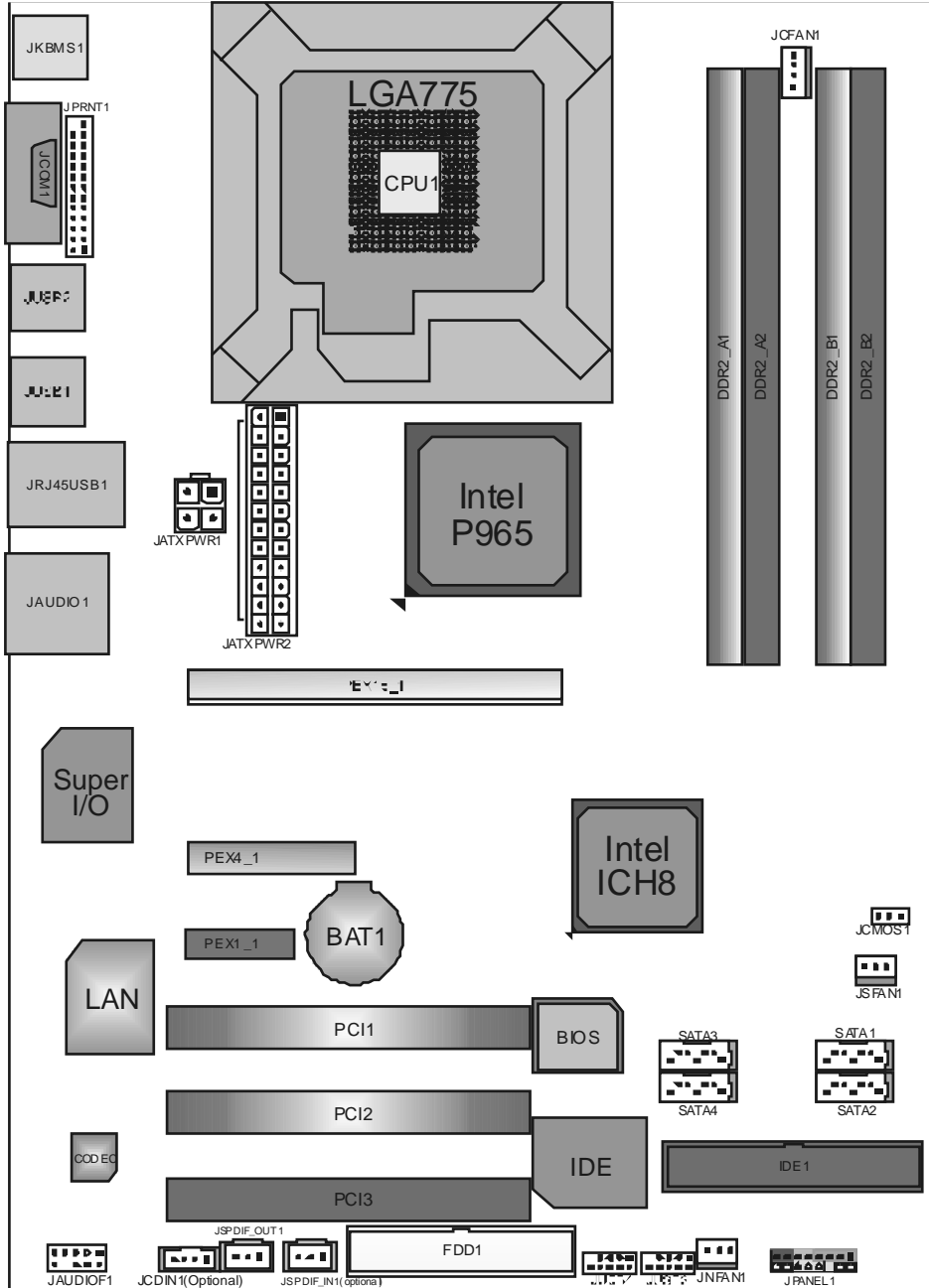

Note: ■ represents the 1st pin.

1.7 MOTHERBOARD LAYOUT (FOR VER 6.X)

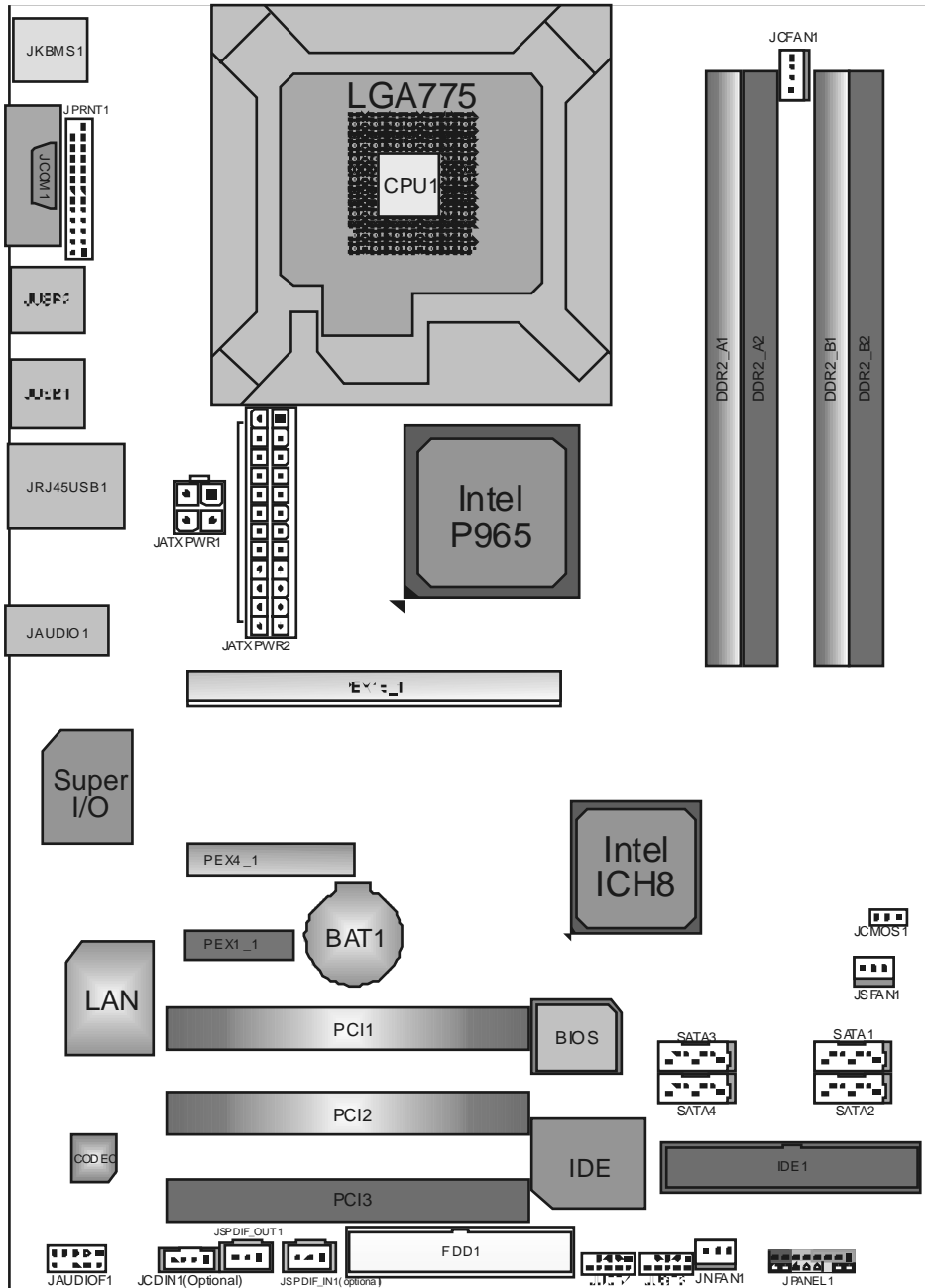

Not e: ■ represents the 1st pin.

CHAPTER 2: HARDWARE INSTALLATION

2.1 INSTALLING CENTRAL PROCESSING UNIT (CPU)

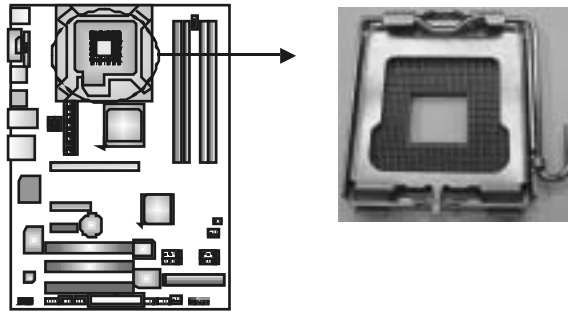

Special Notice

Remove Pin Cap before installation, and make good preservation for future use. When the CPU is removed, cover the Pin Cap on the empty socket to ensure pin legs won't be damaged.



Step 1: Pull the socket locking lever out from the socket and then raise the lever up to a 90-degree angle.

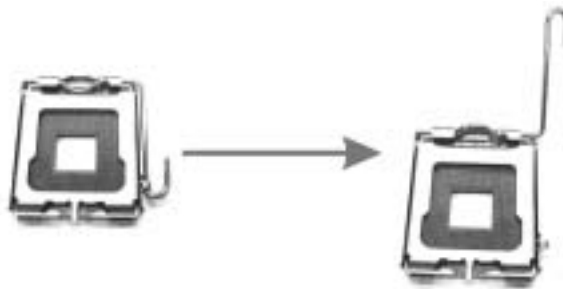

Step 2: Look for the triangular cut edge on socket, and the golden dot on CPU should point forwards this triangular cut edge. The CPU will fit only in the correct orientation.

Step 2-1:

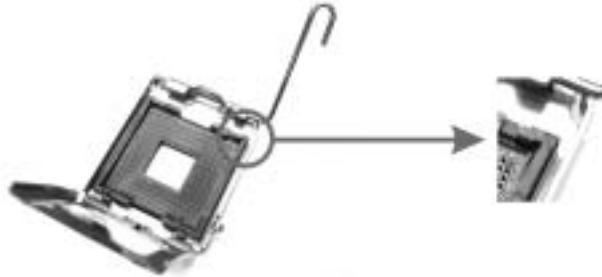

Step 2-2:



Step 3: Hold the CPU down firmly, and then lower the lever to locked position to complete the installation.



Step 4: Put the CPU Fan and heatsink assembly on the CPU and buckle it on the retention frame. Connect the CPU FAN power cable into the JCFAN1. This completes the installation.

2.2 FAN HEADERS

These fan headers support cooling-fans built in the computer. The fan cable and connector may be different according to the fan manufacturer. Connect the fan cable to the connector while matching the black wire to pin#1.

JCFAN1: CPU Fan Header

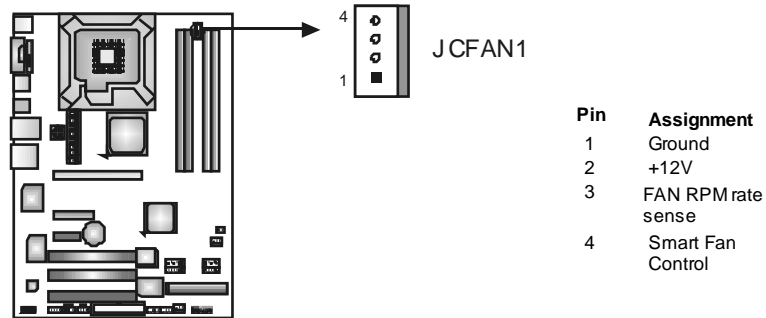

JSFAN1: System Fan Header

JNFAN1: Northbridge Fan Header

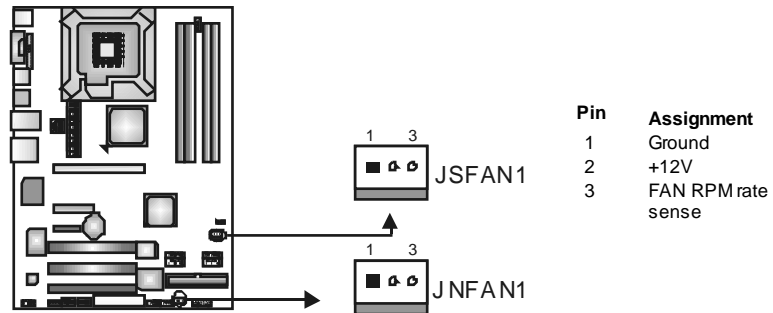

Note:

The JNFAN1 and JSFAN1 support 3-pin head connector. When connecting with wires onto connectors, please note that the red wire is the positive and should be connected to pin#2, and the black wire is Ground and should be connected to GND.

2.3 INSTALLING SYSTEM MEMORY

A. Memory Modules

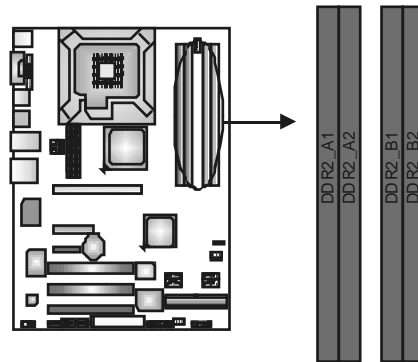

1. Unlock a DIMM slot by pressing the retaining clips outward. Align a DIMM on the slot such that the notch on the DIMM matches the break on the Slot.

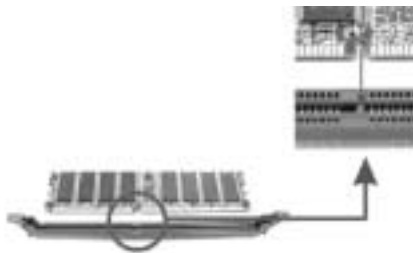

2. Insert the DIMM vertically and firmly into the slot until the retaining chip snap back in place and the DIMM is properly seated.

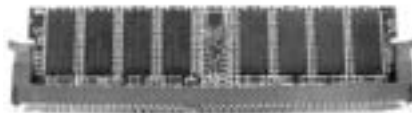

B. Memory Capacity

DIMM Socket Location	DDR Module	Total Memory Size
DDR2_A1	256MB/512MB/1GB/2GB	Max is 8GB.
DDR2_A2	256MB/512MB/1GB/2GB	
DDR2_B1	256MB/512MB/1GB/2GB	
DDR2_B2	256MB/512MB/1GB/2GB	

B. Dual Channel Memory installation

To trigger the Dual Channel function of the motherboard, the memory module must meet the following requirements:

Install memory module of the same density in pairs, shown in the following table.

Dual Channel Status	DDR2_A1	DDR2_A2	DDR2_B1	DDR2_B2
Enabled	O	X	O	X
Enabled	X	O	X	O
Enabled	O	O	O	O

(O means memory installed, X means memory not installed.)

The DRAM bus width of the memory module must be the same (x8 or x16)

2.4 CONNECTORS AND SLOTS

FDD1: Floppy Disk Connector

The motherboard provides a standard floppy disk connector that supports 360K, 720K, 1.2M, 1.44M and 2.88M floppy disk types. This connector supports the provided floppy drive ribbon cables.

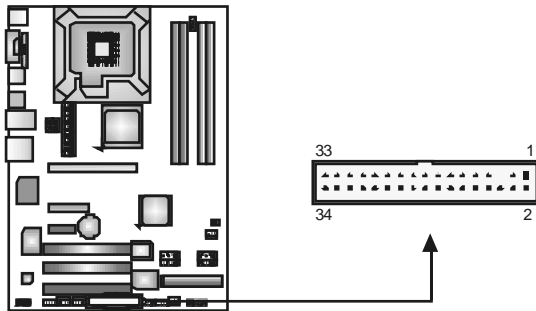

IDE1: Hard Disk Connector

The motherboard has a 32-bit Enhanced PCI IDE Controller that provides PIO Mode 0-4, Bus Master, and Ultra DMA 33/66/100/133 functionality.

The IDE connector can connect a master and a slave drive, so you can connect up to two hard disk drives.

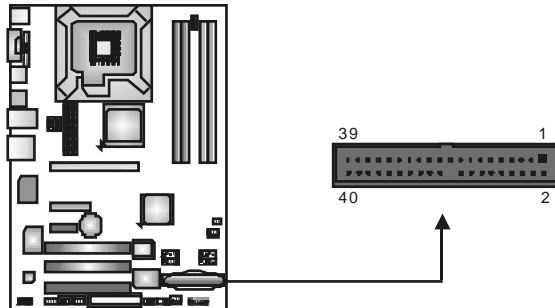

PEX16_1: PCI-Express x16 Slot

- PCI-Express 1.0a compliant.
- Maximum theoretical realized bandwidth of 4GB/s simultaneously per direction, for an aggregate of 8GB/s totally.

PEX4_1: PCI-Express x4 Slot

- PCI-Express 1.0a compliant.
- Maximum theoretical realized bandwidth of 1GB/s simultaneously per direction, for an aggregate of 2GB/s totally.

PEX1_1: PCI-Express Slot

- PCI-Express 1.0a compliant.

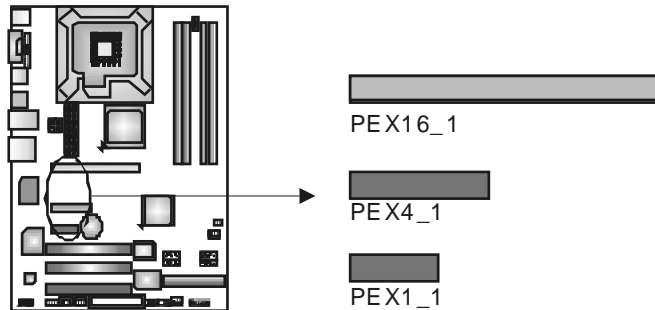

PCI1~PCI3: Peripheral Component Interconnect Slots

This motherboard is equipped with 3 standard PCI slots. PCI stands for Peripheral Component Interconnect, and it is a bus standard for expansion cards. This PCI slot is designated as 32 bits.

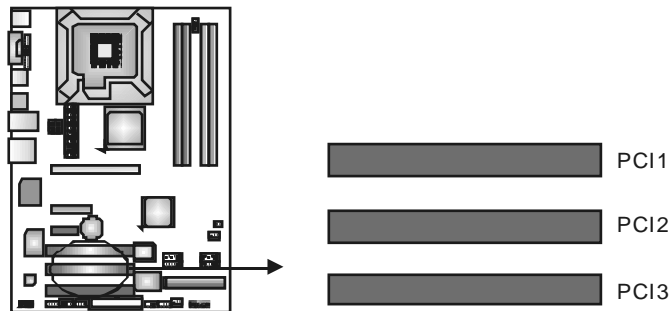

CHAPTER 3: HEADERS & JUMPERS SETUP

3.1 HOW TO SETUP JUMPERS

The illustration shows how to set up jumpers. When the jumper cap is placed on pins, the jumper is “close”, if not, that means the jumper is “open”.



3.2 DETAIL SETTINGS

JPANEL1: Front Panel Header

This 16-pin connector includes Power-on, Reset, HDD LED, Power LED, Sleep button and speaker connection. It allows user to connect the PC case’s front panel switch functions.

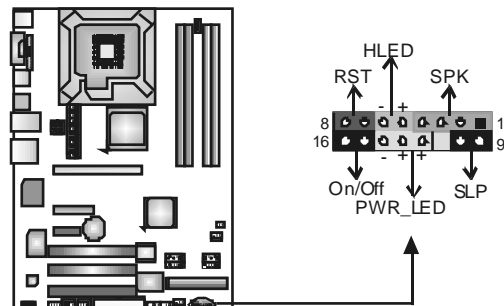

Pin	Assignment	Function	Pin	Assignment	Function
1	+5V	Speaker Connector	9	Sleep control	Sleep button
2	N/A		10	Ground	
3	N/A		11	N/A	N/A
4	Speaker	Hard drive LED	12	Power LED (+)	Power LED
5	HDD LED (+)		13	Power LED (+)	
6	HDD LED (-)	Reset button	14	Power LED (-)	Power-on button
7	Ground		15	Power button	
8	Reset control		16	Ground	

ATX Power Source Connector: JATXPWR2

JATXPWR2 allows user to connect 24-pin power connector on the ATX power supply.

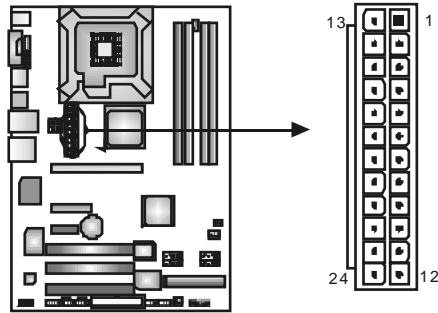

Pin	Assignment	Pin	Assignment
13	+3.3V	1	+3.3V
14	-12V	2	+3.3V
15	Ground	3	Ground
16	PS_ON	4	+5V
17	Ground	5	Ground
18	Ground	6	+5V
19	Ground	7	Ground
20	NC	8	PW_OK
21	+5V	9	Standby Voltage+5V
22	+5V	10	+12V
23	+5V	11	+12V
24	Ground	12	+3.3V

JATXPWR1: ATX Power Source Connector

By connecting this connector, it will provide +12V to CPU power circuit.

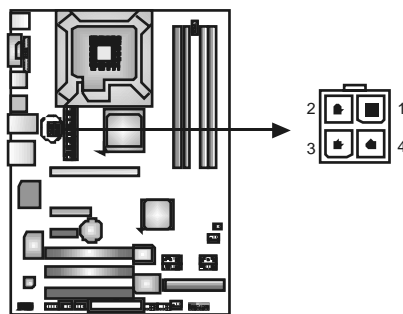

Pin	Assignment
1	+12V
2	+12V
3	Ground
4	Ground

JUSB3/JUSB4: Headers for USB 2.0 Ports at Front Panel

This header allows user to connect additional USB cable on the PC front panel, and also can be connected with internal USB devices, like USB card reader.

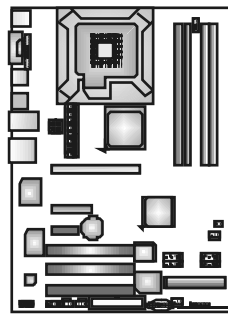

Pin	Assignment
1	+5V (fused)
2	+5V (fused)
3	USB-
4	USB-
5	USB+
6	USB+
7	Ground
8	Ground
9	Key
10	NC

JAUDIO F1: Front Panel Audio Header

This header allows user to connect the front audio output cable with the PC front panel. It will disable the output on back panel audio connectors.

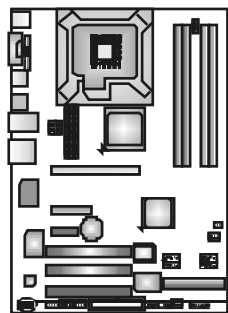

Pin	Assignment
1	Mic in/center
2	Ground
3	Mic power/Bass
4	Audio power
5	Right line out/ Speaker out Right
6	Right line out/ Speaker out Right
7	Reserved
8	Key
9	Left line out/ Speaker out Left
10	Left line out/ Speaker out Left

JCDIN1: CD-ROM Audio-in Connector (Optional)

This connector allows user to connect the audio source from the variety devices, like CD-ROM, DVD-ROM, PCI sound card, PCI TV turner card etc..

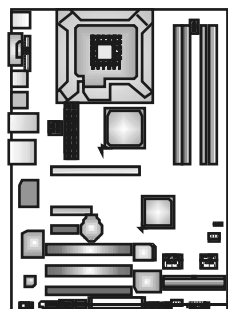

Pin	Assignment
1	Left Channel Input
2	Ground
3	Ground
4	Right Channel Input

JCMOS1: Clear CMOS Header

By placing the jumper on pin2-3, it allows user to restore the BIOS safe setting and the CMOS data, please carefully follow the procedures to avoid damaging the motherboard.

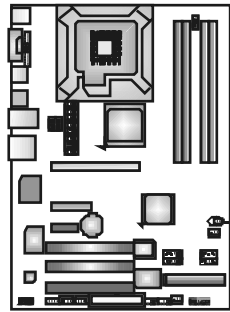

Pin 1-2 Close:
Normal Operation (default).



Pin 2-3 Close:
Clear CMOS data.

※ Clear CMOS Procedures:

1. Remove AC power line.
2. Set the jumper to "Pin 2-3 close".
3. Wait for five seconds.
4. Set the jumper to "Pin 1-2 close".
5. Power on the AC.
6. Reset your desired password or clear the CMOS data.

SATA1/SATA2/SATA3/SATA4: Serial ATA Connectors

The motherboard has a PCI to SATA Controller with 4 channels SATA interface, it satisfies the SATA 2.0 spec and with transfer rate of 3.0Gb/s.

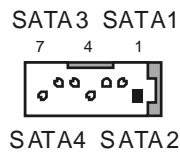
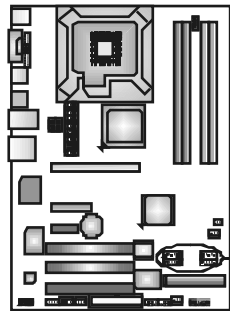

Pin	Assignment
1	Ground
2	TX+
3	TX-
4	Ground
5	RX-
6	RX+
7	Ground

JSPDIF_OUT1: Digital Audio-out Connector

This connector allows user to connect the PCI bracket SPDIF output header.

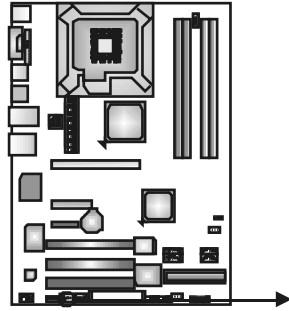

Pin	Assignment
1	+5V
2	SPDIF_OUT
3	Ground



JSPDIF_IN1: Digital Audio-in Connector (Optional)

This connector allows user to connect the PCI bracket SPDIF input header.

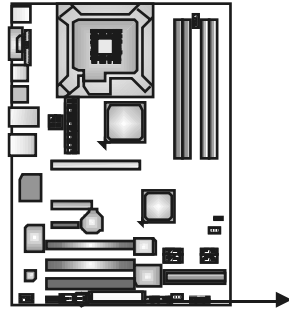

Pin	Assignment
1	+5V
2	SPDIF_IN
3	Ground

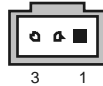

JPRNT1: Printer Port Connector

This header allows you to connector printer on the PC.

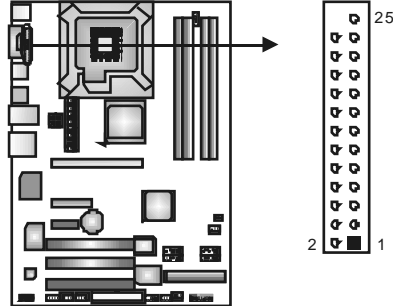

Pin	Assignment	Pin	Assignment
1	-Strobe	14	Ground
2	-ALF	15	Data 6
3	Data 0	16	Ground
4	-Error	17	Data 7
5	Data 1	18	Ground
6	-Init	19	-ACK
7	Data 2	20	Ground
8	-Scltin	21	Bus y
9	Data 3	22	Ground
10	Ground	23	PE
11	Data 4	24	Ground
12	Ground	25	SCLT
13	Data 5	26	Key

CHAPTER 4: USEFUL HELP

4.1 DRIVER INSTALLATION NOTE

After you installed your operating system, please insert the Fully Setup Driver CD into your optical drive and install the driver for better system performance.

You will see the following window after you insert the CD

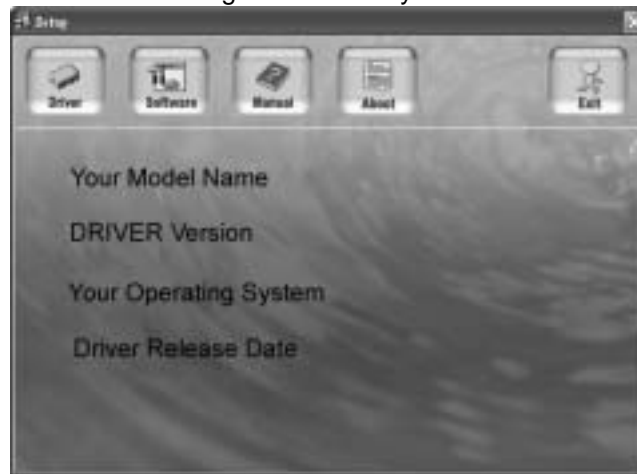

The setup guide will auto detect your motherboard and operating system.

Note:

If this window didn't show up after you insert the Driver CD, please use file browser to locate and execute the file **SETUP.EXE** under your optical drive.

A. Driver Installation

To install the driver, please click on the Driver icon. The setup guide will list the compatible driver for your motherboard and operating system. Click on each device driver to launch the installation program.

B. Software Installation

To install the software, please click on the Software icon. The setup guide will list the software available for your system, click on each software title to launch the installation program.

C. Manual

Aside from the paperback manual, we also provide manual in the Driver CD. Click on the Manual icon to browse for available manual.

Note:

You will need Acrobat Reader to open the manual file. Please download the latest version of Acrobat Reader software from <http://www.adobe.com/products/acrobat/readstep2.html>

4.2 AWARD BIOS BEEP CODE

Beep Sound	Meaning
One long beep followed by two short beeps	Video card not found or video card memory bad
High-low siren sound	CPU overheated System will shut down automatically
One Short beep when system boot-up	No error found during POST
Long beeps every other second	No DRAM detected or install

4.3 EXTRA INFORMATION

A. BIOS Update

After you fail to update BIOS or BIOS is invaded by virus, the Boot-Block function will help to restore BIOS. If the following message is shown after boot-up the system, it means the BIOS contents are corrupted.

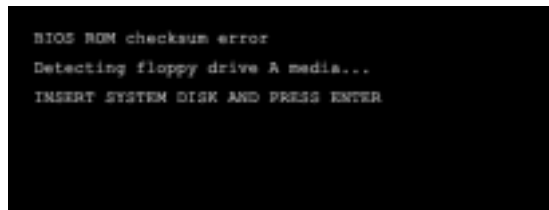

In this Case, please follow the procedure below to restore the BIOS:

1. Make a bootable floppy disk.
2. Download the Flash Utility "AWDFLASH.exe" from the Biostar website: www.biostar.com.tw
3. Confirm motherboard model and download the respectively BIOS from Biostar website.
4. Copy "AWDFLASH.exe" and respectively BIOS into floppy disk.
5. Insert the bootable disk into floppy drive and press Enter.
6. System will boot-up to DOS prompt.
7. Type "Awdflash xxxx.bf/sn/py/r" in DOS prompt.
(xxxx means BIOS name.)
8. System will update BIOS automatically and restart.
9. The BIOS has been recovered and will work properly.

B. CPU Overheated

If the system shutdown automatically after power on system for seconds, that means the CPU protection function has been activated.

When the CPU is over heated, the motherboard will shutdown automatically to avoid a damage of the CPU, and the system may not power on again.

In this case, please double check:

1. The CPU cooler surface is placed evenly with the CPU surface.
2. CPU fan is rotated normally.
3. CPU fan speed is fulfilling with the CPU speed.

After confirmed, please follow steps below to relief the CPU protection function.

1. Remove the power cord from power supply for seconds.
2. Wait for seconds.
3. Plug in the power cord and boot up the system.

Or you can:

1. Clear the CMOS data.
(See "Close CMOS Header: JCMOS1" section)
2. Wait for seconds.
3. Power on the system again.

4.4 TROUBLESHOOTING

Probable	Solution
1. No power to the system at all Power light don't illuminate, fan inside power supply does not turn on. 2. Indicator light on key board does not turn on.	1. Make sure power cable is securely plugged in. 2. Replace cable. 3. Contact technical support.
System inoperative. Keyboard lights are on, power indicator lights are lit, and hard drive is spinning.	Using even pressure on both ends of the DIMM, press down firmly until the module snaps into place.
System does not boot from hard disk drive, can be booted from optical drive.	1. Check cable running from disk to disk controller board. Make sure both ends are securely plugged in; check the drive type in the standard CMOS setup. 2. Backing up the hard drive is extremely important. All hard disks are capable of breaking down at any time.
System only boots from optical drive. Hard disk can be read and applications can be used but booting from hard disk is impossible.	1. Back up data and applications files. 2. Reformat the hard drive. Re-install applications and data using backup disks.
Screen message says "Invalid Configuration" or "CMOS Failure."	Review system's equipment. Make sure correct information is in setup.
Cannot boot system after installing second hard drive.	1. Set master/slave jumpers correctly. 2. Run SETUP program and select correct drive types. Call the drive manufacturers for compatibility with other drives.

CHAPTER 5: WARPSPEEDER™



5.1 INTRODUCTION

[WarpSpeeder™], a new powerful control utility, features three user-friendly functions including Overclock Manager, Overvoltage Manager, and Hardware Monitor.

With the Overclock Manager, users can easily adjust the frequency they prefer or they can get the best CPU performance with just one click. The Overvoltage Manager, on the other hand, helps to power up CPU core voltage and Memory voltage. The cool Hardware Monitor smartly indicates the temperatures, voltage and CPU fan speed as well as the chipset information. Also, in the About panel, you can get detail descriptions about BIOS model and chipsets. In addition, the frequency status of CPU, memory, AGP and PCI along with the CPU speed are synchronically shown on our main panel.

Moreover, to protect users' computer systems if the setting is not appropriate when testing and results in system fail or hang, [WarpSpeeder™] technology assures the system stability by automatically rebooting the computer and then restart to a speed that is either the original system speed or a suitable one.

5.2 SYSTEM REQUIREMENT

OS Support: Windows 98 SE, Windows Me, Windows 2000, Windows XP
DirectX: DirectX 8.1 or above. (The Windows XP operating system includes DirectX 8.1. If you use Windows XP, you do not need to install DirectX 8.1.)

5.3 INSTALLATION

1. Execute the setup execution file, and then the following dialog will pop up. Please click "Next" button and follow the default procedure to install.



2. When you see the following dialog in setup procedure, it means setup is completed. If the "Launch the WarpSpeeder Tray Utility" checkbox is checked, the Tray Icon utility and [WarpSpeeder™] utility will be automatically and immediately launched after you click "Finish" button.



Usage:

The following figures are just only for reference, the screen printed in this user manual will change according to your motherboard on hand.

5.4 WARPSPEDER™

1. **Tray Icon:**

Whenever the Tray Icon utility is launched, it will display a little tray icon on the right side of Windows Taskbar.

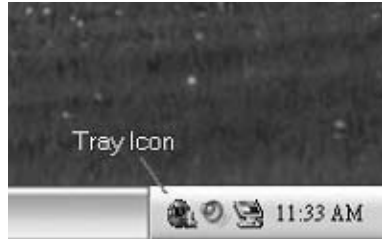

This utility is responsible for conveniently invoking [WarpSpeeder™] Utility. You can use the mouse by clicking the left button in order to invoke [WarpSpeeder™] directly from the little tray icon or you can right-click the little tray icon to pop up a popup menu as following figure. The “Launch Utility” item in the popup menu has the same function as mouse left-click on tray icon and “Exit” item will close Tray Icon utility if selected.



2. Main Panel

If you click the tray icon, [WarpSpeeder™] utility will be invoked. Please refer to the following figure; the utility's first window you will see is Main Panel.

Main Panel contains features as follows:

- Display the CPU Speed, CPU external dock, Memory dock, AGP dock, and PCI dock information.
- Contains About, Voltage, Overclock, and Hardware Monitor Buttons for invoking respective panels.
- With a user-friendly Status Animation, it can represent 3 overclock percentage stages:

Man walking → overclock percentage from 100% ~ 110 %

Panther running → overclock percentage from 110% ~ 120%

Car racing → overclock percentage from 120% ~ above

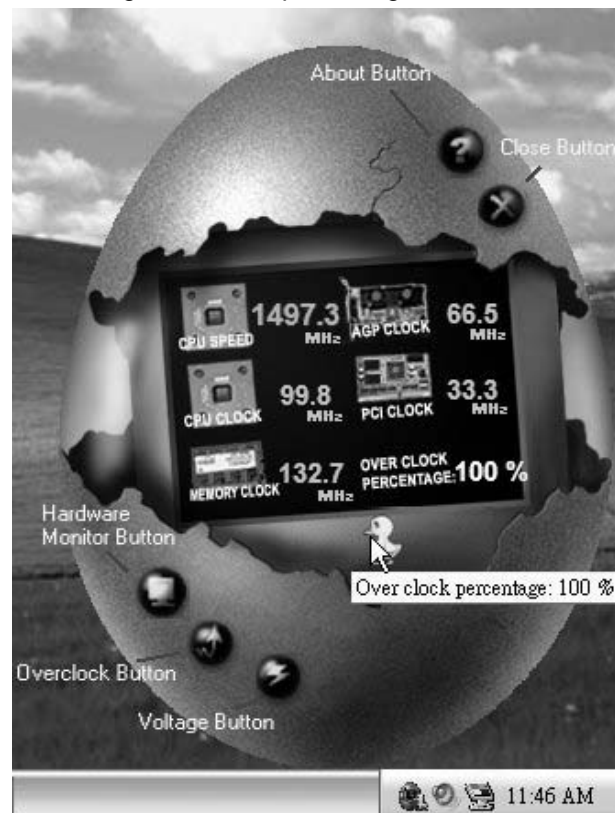

3. Voltage Panel

Click the Voltage button in Main Panel, the button will be highlighted and the Voltage Panel will slide out to up as the following figure.

In this panel, you can decide to increase CPU core voltage and Memory voltage or not. The default setting is "No". If you want to get the best performance of overlocking, we recommend you click the option "Yes".



4. Overclock Panel

Click the Overclock button in Main Panel, the button will be highlighted and the Overclock Panel will slide out to left as the following figure.



Overclock Panel contains the these features:

- “-3MHz button”, “-1MHz button”, “+1MHz button”, and “+3MHz button”:
provide user the ability to do real-time overclock adjustment.

Warning:

Manually overclock is potentially dangerous, especially when the overlocking percentage is over 110 %. We strongly recommend you verify every speed you overclock by click the Verify button. Or, you can just click Auto overclock button and let [WarpSpeeder™] automatically gets the best result for you.

- “Recovery Dialog button”:
Pop up the following dialog. Let user select a restoring way if system need to do a fail-safe reboot.



- c. "Auto-overclock button": User can click this button and [WarpSpeeder™] will set the best and stable performance and frequency automatically. [WarpSpeeder™] utility will execute a series of testing until system fail. Then system will do fail-safe reboot by using Watchdog function. After reboot, the [WarpSpeeder™] utility will restore to the hardware default setting or load the verified best and stable frequency according to the Recovery Dialog's setting.
- d. "Verify button": User can click this button and [WarpSpeeder™] will proceed a testing for current frequency. If the testing is ok, then the current frequency will be saved into system registry. If the testing fail, system will do a fail-safe rebooting. After reboot, the [WarpSpeeder™] utility will restore to the hardware default setting or load the verified best and stable frequency according to the Recovery Dialog's setting.

Note:

Because the testing programs, invoked in Auto-overclock and Verify, include DirectDraw, Direct3D and DirectShow tests, the DirectX 8.1 or newer runtime library is required. And please make sure our display card's color depth is High color (16 bit) or True color (24/32 bit) that is required for Direct3D rendering.

5. Hardware Monitor Panel

Click the Hardware Monitor button in Main Panel, the button will be highlighted and the Hardware Monitor panel will slide out to left as the following figure.

In this panel, you can get the real-time status information of your system. The information will be refreshed every 1 second.



6. About Panel

Click the “about” button in Main Panel, the button will be highlighted and the About Panel will slide out to up as the following figure.

In this panel, you can get model name and detail information in hints of all the chipset that are related to overclocking. You can also get the mainboard’s BIOS model and the Version number of [WarpSpeeder™] utility.

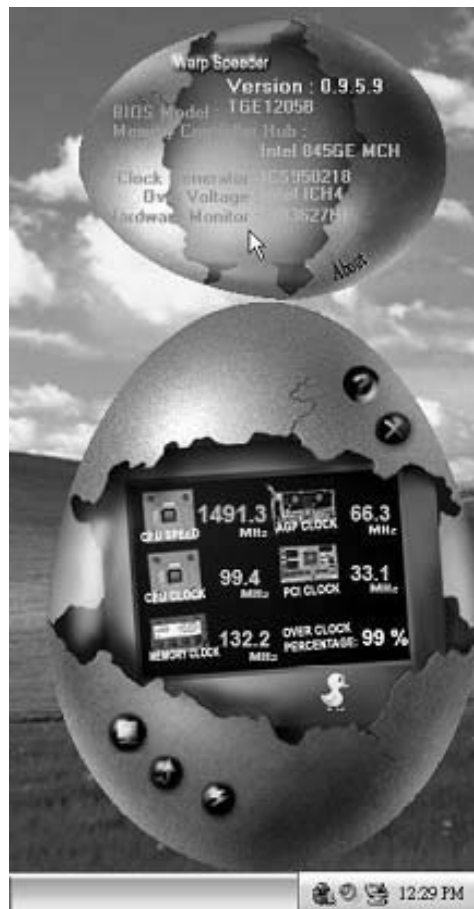

Note:

Because the overclock, overvoltage, and hardware monitor features are controlled by several separate chipset, [WarpSpeeder™] divide these features to separate panels. If one chipset is not on board, the correlative button in Main panel will be disabled, but will not interfere other panels’ functions. This property can make [WarpSpeeder™] utility more robust.

APPENDENCIES: SPEC IN OTHER LANGUAGE**GERMAN**

	<i>Ver 5.x</i>	<i>Ver 6.x</i>
CPU	LGA 775 Intel Core2Duo / Core2Quad / Pentium 4 / Pentium D / Celeron D Prozessoren mit bis zu 3,8 GHz Unterstützt Hyper-Threading / Execute Disable Bit / Enhanced Intel SpeedStep® / Intel Architecture-64 / Extended Memory 64 Technology / Virtualization Technology	LGA 775 Intel Core2Duo / Core2Quad / Pentium 4 / Pentium D / Celeron D Prozessoren mit bis zu 3,8 GHz Unterstützt Hyper-Threading / Execute Disable Bit / Enhanced Intel SpeedStep® / Intel Architecture-64 / Extended Memory 64 Technology / Virtualization Technology
FSB	533 / 800 / 1066 MHz	533 / 800 / 1066 MHz
Chipsatz	Intel P965 Intel ICH8	Intel P965 Intel ICH8
Super E/A	ITE 8712F Bietet die häufig verwendeten alten Super E/A-Funktionen. Low Pin Court-Schnittstelle Umgebungs-kontrolle, Hardware-Überwachung Lüfterdrehzahl-Controller "Smart Guardian"-Funktion von ITE	ITE 8712F Bietet die häufig verwendeten alten Super E/A-Funktionen. Low Pin Court-Schnittstelle Umgebungs-kontrolle, Hardware-Überwachung Lüfterdrehzahl-Controller "Smart Guardian"-Funktion von ITE
Arbeitsspeicher	DDR2 DIMM-Steckplätze x 4 Jeder DIMM unterstützt 256/512MB / 1GB /2GB DDR2. Max. 8GB Arbeitsspeicher Dual-Kanal DDR2 Speichermodul Unterstützt DDR2 533 / 667 / 800 registrierte DIMMs. ECC DIMMs werden nicht unterstützt.	DDR2 DIMM-Steckplätze x 4 Jeder DIMM unterstützt 256/512MB / 1GB /2GB DDR2. Max. 8GB Arbeitsspeicher Dual-Kanal DDR2 Speichermodul Unterstützt DDR2 533 / 667 / 800 registrierte DIMMs. ECC DIMMs werden nicht unterstützt.
IDE	VIA VT6410 Ultra DMA 33 / 66 / 100 / 133 Bus Master-Modus Unterstützt PIO-Modus 0~4,	VIA VT6410 Ultra DMA 33 / 66 / 100 / 133 Bus Master-Modus Unterstützt PIO-Modus 0~4,
SATA II	Integrierter Serial ATA-Controller Daten-Transfer rate bis zu 3Gb/s Konform mit der SATA-Spezifikation Version 2.0.	Integrierter Serial ATA-Controller Daten-Transfer rate bis zu 3Gb/s Konform mit der SATA-Spezifikation Version 2.0.
LAN	Realtek RTL 8110SC 10 / 100 Mb/s und 1Gb/s Auto-Negotiation	Realtek RTL 8110SC 10 / 100 Mb/s und 1Gb/s Auto-Negotiation

	Ver 5.x	Ver 6.x
	Halb-/Voll duplex-Funktion	Halb-/Voll duplex-Funktion
HD	ALC888	ALC861VD
Audio-Unterstützung	Unterstützt Intel High-Definition Audio 7.1-Kanal-Audioausgabe	Unterstützt Intel High-Definition Audio 5.1-Kanal-Audioausgabe
Steckplätze	PCI-Steckplatz x3 PCI Express x16 Steckplatz x1 PCI Express x4 Steckplatz x1 PCI Express x 1-Steckplatz x1	PCI-Steckplatz x3 PCI Express x16 Steckplatz x1 PCI Express x4 Steckplatz x1 PCI Express x 1-Steckplatz x1
Onboard-Anschluss	Diskettenlaufwerkanschluss x1 Druckeranschluss Anschluss x1 IDE-Anschluss x1 SATA-Anschluss x4 Fronttafelanschluss x1 Front-Audioanschluss x1 CD-IN-Anschluss (optional) x1 S/PDIF- Ausgangsanschluss x1 S/PDIF Eingangsanschluss (optional) x1 CPU-Lüfter-Sockel x1 System-Lüfter-Sockel x2 "CMOS löschen"-Sockel x1 USB-Anschluss x2 Stromanschluss (24-polig) x1 Stromanschluss (4-polig) x1	Diskettenlaufwerkanschluss x1 Druckeranschluss Anschluss x1 IDE-Anschluss x1 SATA-Anschluss x4 Fronttafelanschluss x1 Front-Audioanschluss x1 CD-IN-Anschluss (optional) x1 S/PDIF- Ausgangsanschluss x1 S/PDIF Eingangsanschluss (optional) x1 CPU-Lüfter-Sockel x1 System-Lüfter-Sockel x2 "CMOS löschen"-Sockel x1 USB-Anschluss x2 Stromanschluss (24-polig) x1 Stromanschluss (4-polig) x1
Rückseiten-E/A	PS/2-Tastatur x1 PS/2-Maus x1 Serieller Anschluss x1 LAN-Anschluss x1 USB-Anschluss x6 Audioanschluss x6	PS/2-Tastatur x1 PS/2-Maus x1 Serieller Anschluss x1 LAN-Anschluss x1 USB-Anschluss x6 Audioanschluss x3
Platinengröße	220 mm (B) X 305 mm (L)	220 mm (B) X 305 mm (L)
OS-Unterstützung	Windows 2000 / XP / VISTA Biostar behält sich das Recht vor, ohne Ankündigung die Unterstützung für ein Betriebssystem hinzuzufügen oder zu entfernen.	Windows 2000 / XP / VISTA Biostar behält sich das Recht vor, ohne Ankündigung die Unterstützung für ein Betriebssystem hinzuzufügen oder zu entfernen.

FRANCE

	Ver 5.x	Ver 6.x
UC	LGA 775 Processeurs Intel Core2Duo / Core2Quad / Pentium 4 / Pentium D / Celeron D jusqu'à 3,8 GHz Prend en charge les technologies Hyper-Threading / d'exécution de bit de désactivation / Intel SpeedStep® optimisée/ d'architecture Intel 64 / de mémoire étendue 64 / de virtualisation	LGA 775 Processeurs Intel Core2Duo / Core2Quad / Pentium 4 / Pentium D / Celeron D jusqu'à 3,8 GHz Prend en charge les technologies Hyper-Threading / d'exécution de bit de désactivation / Intel SpeedStep® optimisée/ d'architecture Intel 64 / de mémoire étendue 64 / de virtualisation
Bus frontal	533 / 800 / 1066 MHz	533 / 800 / 1066 MHz
Chipset	Intel P965 Intel ICH8	Intel P965 Intel ICH8
Super E/S	ITE 8712F Fournit la fonctionnalité de Super E/S patrimoniales la plus utilisée. Interface à faible compte de broches Initiatives de contrôle environnementales, Moniteur de matériel Contrôleur de vitesse de ventilateur Fonction "Garden intelligent" de l'ITE	ITE 8712F Fournit la fonctionnalité de Super E/S patrimoniales la plus utilisée. Interface à faible compte de broches Initiatives de contrôle environnementales, Moniteur de matériel Contrôleur de vitesse de ventilateur Fonction "Garden intelligent" de l'ITE
Mémoire principale	Fentes DDR2 DIMM x 4 Chaque DIMM prend en charge des DDR2 de 256/512 Mo 1Go /2Go Capacité mémoire maximale de 8 Go Module de mémoire DDR2 à mode à double voie Prend en charge la DDR2 533 / 667 / 800 Les DIMM à registres et DIMM avec code correcteurs d'erreurs ne sont pas prises en charge	Fentes DDR2 DIMM x 4 Chaque DIMM prend en charge des DDR2 de 256/512 Mo 1Go /2Go Capacité mémoire maximale de 8 Go Module de mémoire DDR2 à mode à double voie Prend en charge la DDR2 533 / 667 / 800 Les DIMM à registres et DIMM avec code correcteurs d'erreurs ne sont pas prises en charge
IDE	VIA VT6410 Mode principale de Bus Ultra DMA 33/ 66 / 100 / 133 Prend en charge le mode PIO 0~4,	VIA VT6410 Mode principale de Bus Ultra DMA 33/ 66 / 100 / 133 Prend en charge le mode PIO 0~4,
SATA II	Contrôleur Serial ATA intégré : Taux de transfert jusqu'à 3 Go/s. Conforme à la spécification SATA Version 2.0	Contrôleur Serial ATA intégré : Taux de transfert jusqu'à 3 Go/s. Conforme à la spécification SATA Version 2.0
LAN	Realtek RTL 8110SC	Realtek RTL 8110SC

	Ver 5.x	Ver 6.x
	10 / 100Mb/s et 1Gb/s négociation automatique Half / Full duplex capability	10 / 100Mb/s et 1Gb/s négociation automatique Half / Full duplex capability
Prise en charge audio HD	ALC888 Prise en charge de l'audio haute définition Intel Sortie audio à 7.1 voies	ALC861VD Prise en charge de l'audio haute définition Intel Sortie audio à 5.1 voies
Fentes	Fente PCI x3 Slot PCI Express x16 x1 Slot PCI Express x 4 x1 Slot PCI Express x 1 x1	Fente PCI x3 Slot PCI Express x16 x1 Slot PCI Express x 4 x1 Slot PCI Express x 1 x1
Connecteur embarqué	Connecteur de disquette x1 Connecteur de Port d'imprimante x1 Connecteur IDE x1 Connecteur SATA x4 Connecteur du panneau avant x1 Connecteur Audio du panneau avant x1 Connecteur d'entrée CD(en option) x1 Connecteur de sortie S/PDIF x1 Connecteur d'entrée S/PDIF(en option) x1 Embase de ventilateur UC x1 Embase de ventilateur système x2 Embase d'effacement CMOS x1 Connecteur USB x2 Connecteur d'alimentation (24 broches) x1 Connecteur d'alimentation (4 broches) x1	Connecteur de disquette x1 Connecteur de Port d'imprimante x1 Connecteur IDE x1 Connecteur SATA x4 Connecteur du panneau avant x1 Connecteur Audio du panneau avant x1 Connecteur d'entrée CD(en option) x1 Connecteur de sortie S/PDIF x1 Connecteur d'entrée S/PDIF(en option) x1 Embase de ventilateur UC x1 Embase de ventilateur système x2 Embase d'effacement CMOS x1 Connecteur USB x2 Connecteur d'alimentation (24 broches) x1 Connecteur d'alimentation (4 broches) x1
E/S du panneau arrière	Clavier PS/2 x1 Souris PS/2 x1 Port série x1 Port LAN x1 Port USB x6 Fiche audio x6	Clavier PS/2 x1 Souris PS/2 x1 Port série x1 Port LAN x1 Port USB x6 Fiche audio x3
Dimensions de la carte	220 mm (l) X 305 mm (H)	220 mm (l) X 305 mm (H)
Support SE	Windows 2000 / XP / VISTA Biostar se réserve le droit d'ajouter ou de supprimer le support de SE avec ou sans préavis.	Windows 2000 / XP / VISTA Biostar se réserve le droit d'ajouter ou de supprimer le support de SE avec ou sans préavis.

ITALIAN

	<i>Ver 5.x</i>	<i>Ver 6.x</i>
CPU	LGA 775 Processore Intel Core2Duo / Core2Quad / Pentium 4 / Pentium D / Celeron D fino a 3.8 GHz Supporto di Hyper-Threading / Execute Disable Bit / Enhanced Intel SpeedStep® / Architettura Intel 64 / Tecnologia Extended Memory 64 / Tecnologia Virtualization	LGA 775 Processore Intel Core2Duo / Core2Quad / Pentium 4 / Pentium D / Celeron D fino a 3.8 GHz Supporto di Hyper-Threading / Execute Disable Bit / Enhanced Intel SpeedStep® / Architettura Intel 64 / Tecnologia Extended Memory 64 / Tecnologia Virtualization
FSB	533 / 800 / 1066 MHz	533 / 800 / 1066 MHz
Chipset	Intel P965 Intel ICH8	Intel P965 Intel ICH8
Super I/O	ITE 8712F Fornisce le funzionalità legacy Super I/O usate più comunemente. Interfaccia LPC (Low Pin Count) Funzioni di controllo dell'ambiente: Monitoraggio hardware Controller velocità ventolina Funzione "Smart Guardian" di ITE	ITE 8712F Fornisce le funzionalità legacy Super I/O usate più comunemente. Interfaccia LPC (Low Pin Count) Funzioni di controllo dell'ambiente: Monitoraggio hardware Controller velocità ventolina Funzione "Smart Guardian" di ITE
Memoria principale	Alloggi DIMM DDR 2 x 4 Ciascun DIMM supporta DDR2 256/512MB / 1GB / 2GB Capacità massima della memoria 8GB Modulo di memoria DDR2 a canale doppio Supporto di DDR2 533 / 667 / 800 DIMM registrati e DIMM ECC sono supportati	Alloggi DIMM DDR 2 x 4 Ciascun DIMM supporta DDR2 256/512MB / 1GB / 2GB Capacità massima della memoria 8GB Modulo di memoria DDR2 a canale doppio Supporto di DDR2 533 / 667 / 800 DIMM registrati e DIMM ECC sono supportati
IDE	VIA VT6410 Modalità Bus Master Ultra DMA 33 / 66 / 100 / 133 Supporto modalità PIO Mode 0-4	VIA VT6410 Modalità Bus Master Ultra DMA 33 / 66 / 100 / 133 Supporto modalità PIO Mode 0-4
SATA II	Controller Serial ATA integrato Velocità di trasferimento dei dati fino a 3 Gb/s. Compatibile specifiche SATA Versione 2.0.	Controller Serial ATA integrato Velocità di trasferimento dei dati fino a 3 Gb/s. Compatibile specifiche SATA Versione 2.0.

	Ver 5.x	Ver 6.x
LAN	Realtek RTL 8110SC Negoziazione automatica 10 / 100Mb/s e 1Gb/s Capacità Half / Full Duplex	Realtek RTL 8110SC Negoziazione automatica 10 / 100Mb/s e 1Gb/s Capacità Half / Full Duplex
Supporto audio HD	ALC888 Supporto audio High-Definition (HD) Uscita audio 7.1 canali	ALC861VD Supporto audio High-Definition (HD) Uscita audio 5.1 canali
Alloggi	Alloggio PCI x3 Alloggio PCI Express x16 x1 Alloggio PCI Express x4 x1 Alloggio PCI Express x1 x1	Alloggio PCI x3 Alloggio PCI Express x16 x1 Alloggio PCI Express x4 x1 Alloggio PCI Express x1 x1
Connettori su scheda	Connettore floppy x1 Connettore Porta stampante x1 Connettore IDE x1 Connettore SATA x4 Connettore pannello frontale x1 Connettore audio frontale x1 Connettore CD-in (optional) x1 Connettore output SPDIF x1 Connettore input SPDIF (optional) x1 Collettore ventolina CPU x1 Collettore ventolina sistema x2 Collettore cancellazione CMOS x1 Connettore USB x2 Connettore alimentazione (24 pin) x1 Connettore alimentazione (4 pin) x1	Connettore floppy x1 Connettore Porta stampante x1 Connettore IDE x1 Connettore SATA x4 Connettore pannello frontale x1 Connettore audio frontale x1 Connettore CD-in (optional) x1 Connettore output SPDIF x1 Connettore input SPDIF (optional) x1 Collettore ventolina CPU x1 Collettore ventolina sistema x2 Collettore cancellazione CMOS x1 Connettore USB x2 Connettore alimentazione (24 pin) x1 Connettore alimentazione (4 pin) x1
I/O pannello posteriore	Tastiera PS/2 x1 Mouse PS/2 x1 Porta seriale x1 Porta LAN x1 Porta USB x6 Connettore audio x6	Tastiera PS/2 x1 Mouse PS/2 x1 Porta seriale x1 Porta LAN x1 Porta USB x6 Connettore audio x3
Dimensioni scheda	220 mm (larghezza) x 305 mm (altezza)	220 mm (larghezza) x 305 mm (altezza)
Sistemi operativi supportati	Windows 2000 / XP / VISTA Biostar si riserva il diritto di aggiungere o rimuovere il supporto di qualsiasi sistema operativo senza preavviso.	Windows 2000 / XP / VISTA Biostar si riserva il diritto di aggiungere o rimuovere il supporto di qualsiasi sistema operativo senza preavviso.

SPANISH

	<i>Ver 5.x</i>	<i>Ver 6.x</i>
CPU	LGA 775 Procesador Intel Core2Duo / Core2Quad / Pentium 4 / Pentium D / Celeron D hasta 3,8 GHz Admite Hyper-Threading / Bit de deshabilitación de ejecución / Intel SpeedStep® Mejorado / Intel Architecture-64 / Tecnología Extended Memory 64 / Tecnología de virtualización	LGA 775 Procesador Intel Core2Duo / Core2Quad / Pentium 4 / Pentium D / Celeron D hasta 3,8 GHz Admite Hyper-Threading / Bit de deshabilitación de ejecución / Intel SpeedStep® Mejorado / Intel Architecture-64 / Tecnología Extended Memory 64 / Tecnología de virtualización
FSB	533 / 800 / 1066 MHz	533 / 800 / 1066 MHz
Conjunto de chips	Intel P965 Intel ICH8	Intel P965 Intel ICH8
Súper E/S	ITE 8712F Le ofrece las funcionalidades heredadas de uso más común Súper E/S. Interfaz de cuenta Low Pin Iniciativas de control de entorno, Monitor hardware Controlador de velocidad de ventilador Función "Guarda inteligente" de ITE	ITE 8712F Le ofrece las funcionalidades heredadas de uso más común Súper E/S. Interfaz de cuenta Low Pin Iniciativas de control de entorno, Monitor hardware Controlador de velocidad de ventilador Función "Guarda inteligente" de ITE
Memoria principal	Ranuras DIMM DDR2 x 4 Cada DIMM admite DDR de 256/512MB / 1GB / 2GB Capacidad máxima de memoria de 8GB Módulo de memoria DDR2 de canal Doble Admite DDR2 de 533 / 667 / 800 No admite DIMM registrados o DIMM compatibles con ECC	Ranuras DIMM DDR2 x 4 Cada DIMM admite DDR de 256/512MB / 1GB / 2GB Capacidad máxima de memoria de 8GB Módulo de memoria DDR2 de canal Doble Admite DDR2 de 533 / 667 / 800 No admite DIMM registrados o DIMM compatibles con ECC
IDE	VIA VT6410 Modo bus maestro Ultra DMA 33 / 66 / 100 / 133 Soporte los Modos PIO 0~4,	VIA VT6410 Modo bus maestro Ultra DMA 33 / 66 / 100 / 133 Soporte los Modos PIO 0~4,
SATA II	Controlador ATA Serie Integrado Tasas de transferencia de hasta 3 Gb/s. Compatible con la versión SATA 2.0.	Controlador ATA Serie Integrado Tasas de transferencia de hasta 3 Gb/s. Compatible con la versión SATA 2.0.
Red Local	Realtek RTL 8110SC Negociación de 10 / 100 Mb/s y 1 Gb/s Funciones Half / Full dúplex	Realtek RTL 8110SC Negociación de 10 / 100 Mb/s y 1 Gb/s Funciones Half / Full dúplex

	Ver 5.x	Ver 6.x
Soporte de sonido HD	ALC888 Soporte de sonido Intel de Alta Definición Salida de sonido de 7.1 canales	ALC861VD Soporte de sonido Intel de Alta Definición Salida de sonido de 5.1 canales
Ranuras	Ranura PCI X3 Ranura PCI Express x16 X1 Ranura PCI Express x4 X1 Ranura PCI express x 1 X1	Ranura PCI X3 Ranura PCI Express x16 X1 Ranura PCI Express x4 X1 Ranura PCI express x 1 X1
Conectores en placa	Conector disco flexible X1 Conector Puerto de impresora X1 Conector IDE X1 Conector SATA X4 Conector de panel frontal X1 Conector de sonido frontal X1 Conector de entrada de CD(opcional) X1 Conector de salida S/PDIF X1 Conector de entrada S/PDIF(opcional) x1 Cabecera de ventilador de CPU X1 Cabecera de ventilador de sistema X2 Cabecera de borrado de CMOS X1 Conector USB X2 Conector de alimentación X1 (24 patillas) Conector de alimentación X1 (4 patillas)	Conector disco flexible X1 Conector Puerto de impresora X1 Conector IDE X1 Conector SATA X4 Conector de panel frontal X1 Conector de sonido frontal X1 Conector de entrada de CD(opcional) X1 Conector de salida S/PDIF X1 Conector de entrada S/PDIF(opcional) x1 Cabecera de ventilador de CPU X1 Cabecera de ventilador de sistema X2 Cabecera de borrado de CMOS X1 Conector USB X2 Conector de alimentación X1 (24 patillas) Conector de alimentación X1 (4 patillas)
Panel trasero de E/S	Teclado PS/2 X1 Ratón PS/2 X1 Puerto serie X1 Puerto de red local X1 Puerto USB X6 Conector de sonido X6	Teclado PS/2 X1 Ratón PS/2 X1 Puerto serie X1 Puerto de red local X1 Puerto USB X6 Conector de sonido X3
Tamaño de la placa	220 mm. (A) X 305 Mm. (H)	220 mm. (A) X 305 Mm. (H)
Soporte de sistema operativo	Windows 2000 / XP / VISTA Biostar se reserva el derecho de añadir o retirar el soporte de cualquier SO con o sin aviso previo.	Windows 2000 / XP / VISTA Biostar se reserva el derecho de añadir o retirar el soporte de cualquier SO con o sin aviso previo.

PORTUGUESE

	<i>Ver 5.x</i>	<i>Ver 6.x</i>
CPU	LGA 775 Processador Intel Core2Duo / Core2Quad / Pentium 4 / Pentium D / Celeron D até 3,8 GHz Suporta as tecnologias Hyper-Threading / Execute Disable Bit / Enhanced Intel SpeedStep® / Intel Architecture -64 / Extended Memory 64 / Virtualization	LGA 775 Processador Intel Core2Duo / Core2Quad / Pentium 4 / Pentium D / Celeron D até 3,8 GHz Suporta as tecnologias Hyper-Threading / Execute Disable Bit / Enhanced Intel SpeedStep® / Intel Architecture -64 / Extended Memory 64 / Virtualization
FSB	533 / 800 / 1066 MHz	533 / 800 / 1066 MHz
Chipset	Intel P965 Intel ICH8	Intel P965 Intel ICH8
Especificação Super I/O	ITE 8712F Proporciona as funcionalidades mais utilizadas em termos da especificação Super I/O. Interface LPC (Low Pin Count). Iniciativas para controlo do ambiente Monitorização do hardware Controlador da velocidade da ventoinha Função "Smart Guardian" da ITE	ITE 8712F Proporciona as funcionalidades mais utilizadas em termos da especificação Super I/O. Interface LPC (Low Pin Count). Iniciativas para controlo do ambiente Monitorização do hardware Controlador da velocidade da ventoinha Função "Smart Guardian" da ITE
Memória principal	Ranuras DIMM DDR2 x 4 Cada módulo DIMM suporta uma memória DDR2 de 256/512 MB / 1 GB / 2GB Capacidade máxima de memória: 8 GB Módulo de memória DDR2 de canal duplo Suporta módulos DDR2 533 / 667 / 800 Os módulos DIMM registados e os DIMM ECCsão suportados	Ranuras DIMM DDR2 x 4 Cada módulo DIMM suporta uma memória DDR2 de 256/512 MB / 1 GB / 2GB Capacidade máxima de memória: 8 GB Módulo de memória DDR2 de canal duplo Suporta módulos DDR2 533 / 667 / 800 Os módulos DIMM registados e os DIMM ECCsão suportados
IDE	VIA VT6410 Modo Bus master Ultra DMA 33 / 66 / 100 / 133 Suporta o modo PIO 0~4,	VIA VT6410 Modo Bus master Ultra DMA 33 / 66 / 100 / 133 Suporta o modo PIO 0~4,
SATA II	Controlador Serial ATA integrado Velocidades de transmissão de dados até 3 Gb/s. Compatibilidade com a especificação SATA versão 2.0.	Controlador Serial ATA integrado Velocidades de transmissão de dados até 3 Gb/s. Compatibilidade com a especificação SATA versão 2.0.
LAN	Realtek RTL 8110SC Auto negociação de 10 / 100Mb/s e 1Gb/s Capacidade semi/full-duplex	Realtek RTL 8110SC Auto negociação de 10 / 100Mb/s e 1Gb/s Capacidade semi/full-duplex

	<i>Ver 5.x</i>	<i>Ver 6.x</i>
Suporte para áudio de alta definição	ALC888 Suporta a especificação Intel High-Definition Audio Saída de áudio de 7.1 canais	ALC861VD Suporta a especificação Intel High-Definition Audio Saída de áudio de 5.1 canais
Ranhuras	Ranhura PCI x3 Ranhura PCI Express x16 x1 Ranhura PCI Express x4 x1 Ranhura PCI Express x 1 x1	Ranhura PCI x3 Ranhura PCI Express x16 x1 Ranhura PCI Express x4 x1 Ranhura PCI Express x 1 x1
Conectores na placa	Conector da unidade de disquetes x1 Conector da para impressora x1 Conector IDE x1 Conector SATA x4 Conector do painel frontal x1 Conector de áudio frontal x1 Conector para entrada de CDs(opcional)x1 Conector de saída S/PDIF x1 Conector de entrada S/PDIF (opcional) x1 Conector da vertinha da CPU x1 Conector da vertinha do sistema x2 Conector para limpeza do CMOS x1 Conector USB x2 Conector de alimentação (24 pinos) x1 Conector de alimentação (4 pinos) x1	Conector da unidade de disquetes x1 Conector da para impressora x1 Conector IDE x1 Conector SATA x4 Conector do painel frontal x1 Conector de áudio frontal x1 Conector para entrada de CDs(opcional)x1 Conector de saída S/PDIF x1 Conector de entrada S/PDIF (opcional) x1 Conector da vertinha da CPU x1 Conector da vertinha do sistema x2 Conector para limpeza do CMOS x1 Conector USB x2 Conector de alimentação (24 pinos) x1 Conector de alimentação (4 pinos) x1
Entradas/Saídas no painel traseiro	Teclado PS/2 x1 Rato PS/2 x1 Porta série x1 Porta LAN x1 Porta USB x6 Tomada de áudio x6	Teclado PS/2 x1 Rato PS/2 x1 Porta série x1 Porta LAN x1 Porta USB x6 Tomada de áudio x3
Tamanho da placa	220 mm (L) X 305 mm (A)	220 mm (L) X 305 mm (A)
Sistemas operativos suportados	Windows 2000 / XP / VISTA A Biostar reserva-se o direito de adicionar ou remover suporte para qualquer sistema operativo com ou sem aviso prévio.	Windows 2000 / XP / VISTA A Biostar reserva-se o direito de adicionar ou remover suporte para qualquer sistema operativo com ou sem aviso prévio.

POLISH

	<i>Ver 5.x</i>	<i>Ver 6.x</i>
Procesor	LGA 775 Procesor Intel Core2Duo / Core2Quad / Pentium 4 / Pentium D / Celeron D do 3,8 GHz Obsługa Hyper-Threading / Execute Disable Bit / Enhanced Intel SpeedStep® / Intel Architecture-64 / Extended Memory 64 Technology / Virtualization Technology	LGA 775 Procesor Intel Core2Duo / Core2Quad / Pentium 4 / Pentium D / Celeron D do 3,8 GHz Obsługa Hyper-Threading / Execute Disable Bit / Enhanced Intel SpeedStep® / Intel Architecture-64 / Extended Memory 64 Technology / Virtualization Technology
FSB	533 / 800 / 1066 MHz	533 / 800 / 1066 MHz
Chipset	Intel P965 Intel ICH8	Intel P965 Intel ICH8
Pamięć główna	Gniazda DDR2 DIMM x 4 Każde gniazdo DIMM obsługuje moduły 256/512MB / 1GB / 2GB DDR2 Maks. wielkość pamięci 8GB Moduł pamięci DDR2 z trybem podwójnego kanału Obsługa DDR2 533 / 667 / 800 Brak obsługi Registered DIMM oraz ECC DIMM	Gniazda DDR2 DIMM x 4 Każde gniazdo DIMM obsługuje moduły 256/512MB / 1GB / 2GB DDR2 Maks. wielkość pamięci 8GB Moduł pamięci DDR2 z trybem podwójnego kanału Obsługa DDR2 533 / 667 / 800 Brak obsługi Registered DIMM oraz ECC DIMM
Super I/O	ITE 8712F Zapewnia najbardziej powszechne funkcje Super I/O. Interfejs Low Pin Count Funkcje kontroli warunków pracy, Monitor H/W Kontroler prędkości wentylatora Funkcja ITE "Smart Guardian"	ITE 8712F Zapewnia najbardziej powszechne funkcje Super I/O. Interfejs Low Pin Count Funkcje kontroli warunków pracy, Monitor H/W Kontroler prędkości wentylatora Funkcja ITE "Smart Guardian"
IDE	VIA VT6410 Ultra DMA 33 / 66 / 100 / 133 Tryb Bus Master obsługa PIO tryb 0~4,	VIA VT6410 Ultra DMA 33 / 66 / 100 / 133 Tryb Bus Master obsługa PIO tryb 0~4,
SATA II	Zintegrowany kontroler Serial ATA Transfer danych do 3 Gb/s. Zgodność ze specyfikacją SATA w wersji 2.0.	Zintegrowany kontroler Serial ATA Transfer danych do 3 Gb/s. Zgodność ze specyfikacją SATA w wersji 2.0.
LAN	Realtek RTL 8110SC 10 / 100 Mb/s oraz 1Gb/s z automatyczną negocjacją szybkości Działanie w trybie półowicznego / pełnego dupleksu	Realtek RTL 8110SC 10 / 100 Mb/s oraz 1Gb/s z automatyczną negocjacją szybkości Działanie w trybie półowicznego / pełnego dupleksu

	<i>Ver 5.x</i>	<i>Ver 6.x</i>
Obsługa audio HD	ALC888 Obsługa Intel High-Definition Audio 7.1 kanałowe wyjście audio	ALC861VD Obsługa Intel High-Definition Audio 5.1 kanałowe wyjście audio
Gniazda	Gniazdo PCI x3 Gniazdo PCI Express x16 x1 Gniazdo PCI Express x 4 x1 Gniazdo PCI Express x 1 x1	Gniazdo PCI x3 Gniazdo PCI Express x16 x1 Gniazdo PCI Express x 4 x1 Gniazdo PCI Express x 1 x1
Złącza wbudowane	Złącze napędu dyskietek x1 Złącze Port drukarki x1 Złącze IDE x1 Złącze SATA x4 Złącze panela przedniego x1 Przednie złącze audio x1 Złącze wejścia CD (opcja) x1 Złącze wyjścia S/PDIF x1 Złącze wejścia S/PDIF (opcja) x1 Złącze głośnikowe wentylatora procesora x1 Złącze głośnikowe wentylatora systemowego x2 Złącze głośnikowe kasowania CMOS x1 Złącze USB x2 Złącze zasilania (24 pinowe) x1 Złącze zasilania (4 pinowe) x1	Złącze napędu dyskietek x1 Złącze Port drukarki x1 Złącze IDE x1 Złącze SATA x4 Złącze panela przedniego x1 Przednie złącze audio x1 Złącze wejścia CD (opcja) x1 Złącze wyjścia S/PDIF x1 Złącze wejścia S/PDIF (opcja) x1 Złącze głośnikowe wentylatora procesora x1 Złącze głośnikowe wentylatora systemowego x2 Złącze głośnikowe kasowania CMOS x1 Złącze USB x2 Złącze zasilania (24 pinowe) x1 Złącze zasilania (4 pinowe) x1
Back Panel I/O	Klawiatura PS/2 x1 Mysz PS/2 x1 Port szeregowy x1 Port LAN x1 Port USB x6 Gniazdo audio x6	Klawiatura PS/2 x1 Mysz PS/2 x1 Port szeregowy x1 Port LAN x1 Port USB x6 Gniazdo audio x3
Wymiary płyty	220 mm (S) X 305 mm (W)	220 mm (S) X 305 mm (W)
Obsługa systemu operacyjnego	Windows 2000 / XP / VISTA Biostar zastrzega sobie prawo dodawania lub odwoływania obsługi dowolnego systemu	Windows 2000 / XP / VISTA Biostar zastrzega sobie prawo dodawania lub odwoływania obsługi dowolnego systemu

RUSSIAN

	Ver 5.x	Ver 6.x
CPU (центральный процессор)	LGA 775 Процессор Intel Core2Duo / Core2Quad / Pentium 4 / Pentium D / Celeron D до 3.8ГГц Поддержка технологий Hyper-Threading / Execute Disable Bit / Enhanced Intel SpeedStep® / Intel Architecture-64 / Extended Memory 64 Technology / технологии виртуализация	LGA 775 Процессор Intel Core2Duo / Core2Quad / Pentium 4 / Pentium D / Celeron D до 3.8ГГц Поддержка технологий Hyper-Threading / Execute Disable Bit / Enhanced Intel SpeedStep® / Intel Architecture-64 / Extended Memory 64 Technology / технологии виртуализация
FSB	533 / 800 / 1066 МГц	533 / 800 / 1066 МГц
Набор микросхем	Intel P965 Intel ICH8	Intel P965 Intel ICH8
Основная память	Слоты DDR2 DIMM x 4 Каждый модуль DIMM поддерживает 256/512МБ / 1ГБ / 2ГБ DDR2 Максимальная ёмкость памяти 8 ГБ Модуль памяти с двухканальным режимом DDR2 Поддержка DDR2 533 / 667 / 800 Не поддерживает зарегистрированные модули DIMM and ECC DIMM	Слоты DDR2 DIMM x 4 Каждый модуль DIMM поддерживает 256/512МБ / 1ГБ / 2ГБ DDR2 Максимальная ёмкость памяти 8 ГБ Модуль памяти с двухканальным режимом DDR2 Поддержка DDR2 533 / 667 / 800 Не поддерживает зарегистрированные модули DIMM and ECC DIMM
Super I/O	ITE 8712F Обеспечивает наиболее используемые действующие функциональные возможности Super I/O. Интерфейс с низким количеством выводов Инициативы по охране окружающей среды, Аппаратный монитор Регулятор скорости Функция ITE "Smart Guardian" (Интеллектуальная защита)	ITE 8712F Обеспечивает наиболее используемые действующие функциональные возможности Super I/O. Интерфейс с низким количеством выводов Инициативы по охране окружающей среды, Аппаратный монитор Регулятор скорости Функция ITE "Smart Guardian" (Интеллектуальная защита)
IDE	VIA VT6410 Режим "хвояина" шины Ultra DMA 33 / 66 / 100 / 133 Поддержка режима PIO 0~4,	VIA VT6410 Режим "хвояина" шины Ultra DMA 33 / 66 / 100 / 133 Поддержка режима PIO 0~4,
SATA II	Встроенное последовательное устройство управления АТА скорость передачи данных до 3 гигабит/с. Соответствие спецификации SATA версия 2.0.	Встроенное последовательное устройство управления АТА скорость передачи данных до 3 гигабит/с. Соответствие спецификации SATA версия 2.0.
Локальная сеть	Realtek RTL 8110SC Автоматическое согласование 10 / 100 Мб/с и 1Гб/с Частичная / полная дуплексная способность	Realtek RTL 8110SC Автоматическое согласование 10 / 100 Мб/с и 1Гб/с Частичная / полная дуплексная способность

	<i>Ver 5.x</i>		<i>Ver 6.x</i>	
Звуковая поддержка жесткого диска	ALC888 Звуковая поддержка Intel High-Definition 7.1канальный звуковой выход		ALC861VD Звуковая поддержка Intel High-Definition 5.1канальный звуковой выход	
Слоты	Слот PCI	x3	Слот PCI	x3
	Слот PCI Express x16	x1	Слот PCI Express x16	x1
	Слот PCI Express x 4	x1	Слот PCI Express x 4	x1
	Слот PCI Express x 1	x1	Слот PCI Express x 1	x1
Встроенный разъем	Разъем НГМД	x1	Разъем НГМД	x1
	Разъем Порт подключения принтера	x1	Разъем Порт подключения принтера	x1
	Разъем IDE	x1	Разъем IDE	x1
	Разъем SATA	x4	Разъем SATA	x4
	Разъем на лицевой панели	x1	Разъем на лицевой панели	x1
	Входной звуковой разъем	x1	Входной звуковой разъем	x1
	Разъем ввода для CD(дополнительно)	x1	Разъем ввода для CD(дополнительно)	x1
	Разъем вывода для S/PDIF	x1	Разъем вывода для S/PDIF	x1
	Разъем ввода для S/PDIF(дополнительно)	x1	Разъем ввода для S/PDIF(дополнительно)	x1
	Контактирующее приспособление вентилятора центрального процессора	x1	Контактирующее приспособление вентилятора центрального процессора	x1
	Контактирующее приспособление вентилятора системы	x2	Контактирующее приспособление вентилятора системы	x2
	Открытое контактирующее приспособление CMOS	x1	Открытое контактирующее приспособление CMOS	x1
	USB-разъем	x2	USB-разъем	x2
Разъем питания (24 вывод)	x1	Разъем питания (24 вывод)	x1	
Разъем питания (4 вывод)	x1	Разъем питания (4 вывод)	x1	
Задняя панель средств ввода-вывода	Клавиатура PS/2	x1	Клавиатура PS/2	x1
	Мышь PS/2	x1	Мышь PS/2	x1
	Последовательный порт	x1	Последовательный порт	x1
	Порт LAN	x1	Порт LAN	x1
	USB-порт	x6	USB-порт	x6
Размер панели	Гнезд для подключения наушников	x6	Гнезд для подключения наушников	x3
	220 мм (Ш) X 305 мм (В)		220 мм (Ш) X 305 мм (В)	
Поддержка OS	Windows 2000 / XP / VISTA Bicstar сохраняет за собой право добавлять или удалять средства обеспечения для OS с или без предварительного уведомления.		Windows 2000 / XP / VISTA Bicstar сохраняет за собой право добавлять или удалять средства обеспечения для OS с или без предварительного уведомления.	

ARABIC

Ver 6.x	Ver 5.x	
LGA 775 Intel Core2Duo/Core2Quad/ Pentium 4/ Pentium D / Celeron D بتردد يصل إلى 3.8 جيجا هرتز Hyper-Threading / Execute Disable Bit / Enhanced Intel SpeedStep® / Intel Architecture-64 / Extended Memory 64 Technology / Virtualization Technology	LGA 775 Intel Core2Duo/Core2Quad/ Pentium 4/ Pentium D / Celeron D بتردد يصل إلى 3.8 جيجا هرتز Hyper-Threading / Execute Disable Bit / Enhanced Intel SpeedStep® / Intel Architecture-64 / Extended Memory 64 Technology / Virtualization Technology	وحدة لمعالجة المركبة
ميجا هرتز 533 / 800 / 1066 تردد	ميجا هرتز 533 / 800 / 1066 تردد	النقل الأمامي لجلب
Intel P965 Intel ICH8	Intel P965 Intel ICH8	مجموعة لشرايح
عدد 4 فتحة DDR2 DIMM ميجا 256/512 سعة DDR2 ذم ذاكورة من نوع DIMM بليت 2 و بليت 1 جيجابايت سعة ذاكرة قصوى 8 جيجا بايت مزوجة لفتحة DDR2 وحدة ذاكرة ساعات 800 / 667 / 533 ميجا بايت ECC وذك التي لا تتوافق مع DIMM لا ذم عرقلق الذاكرة	عدد 4 فتحة DDR2 DIMM ميجا 256/512 سعة DDR2 ذم ذاكورة من نوع DIMM بليت 2 و بليت 1 جيجابايت سعة ذاكرة قصوى 8 جيجا بايت مزوجة لفتحة DDR2 وحدة ذاكرة ساعات 800 / 667 / 533 ميجا بايت ECC وذك التي لا تتوافق مع DIMM لا ذم عرقلق الذاكرة	الذاكرة الرئيسية
ITE 8712F الأكثر لتخدلم، Super I/O توفر وظيفة Low Pin Count Interface وسائل لتحكم في لينت: مراقب لمعومة حللة الأجهزة مراقب في بوعه لمروحة من ITE "Smart Guardian" وظيفة	ITE 8712F الأكثر لتخدلم، Super I/O توفر وظيفة Low Pin Count Interface وسائل لتحكم في لينت: مراقب لمعومة حللة الأجهزة مراقب في بوعه لمروحة من ITE "Smart Guardian" وظيفة	Super I/O
VIA VT6410 متكلم IDE Ultra DMA 33 / 66 / 100 / 133 نقل ببقية وضع رئيسي PIO Mode 0~4 وضع	VIA VT6410 متكلم IDE Ultra DMA 33 / 66 / 100 / 133 نقل ببقية وضع رئيسي PIO Mode 0~4 وضع	منذ IDE
Serial ATA متكلم نقل البيانات بسرعات تصل إلى 3 جيجابت/ثانية. 2.0 الإصدار SATA مطابقة لمواصفات	Serial ATA متكلم نقل البيانات بسرعات تصل إلى 3 جيجابت/ثانية. 2.0 الإصدار SATA مطابقة لمواصفات	SATA II
Realtek RTL 8110SC قروض فئتي 100/10 ميجا بايت / ثانية و 1 جيجا بايت / ثانية إمكانية النقل لمزوج الكامل / قصفي	Realtek RTL 8110SC قروض فئتي 100/10 ميجا بايت / ثانية و 1 جيجا بايت / ثانية إمكانية النقل لمزوج الكامل / قصفي	شبكة داخلية

Ver 6.x	Ver 5.x	
ALC861VD Intel دعم تقنية الصوت عالي تعريف من 5.1 قنوات لخرج الصوت	ALC888 Intel دعم تقنية الصوت عالي تعريف من 7.1 قنوات لخرج الصوت	دعم لصوت عالي التعريف
عدد 3 فتحة PCI عدد 1 فتحة PCI Expressx16 عدد 1 فتحة PCI Expressx4 عدد 1 فتحة PCI Express x 1	عدد 3 فتحة PCI عدد 1 فتحة PCI Expressx16 عدد 1 فتحة PCI Expressx4 عدد 1 فتحة PCI Express x 1	الفتحات
عدد 1 مقعد محرك أقراص مرنة عدد 1 مقعد طابعة عدد 1 مقعد IDE عدد 4 مقعد SATA عدد 1 مقعد اللوحة الأممية عدد 1 مقعد الصوت الأممي عدد 1 مقعد (اختياري) CD-IN عدد 1 مقعد خرج S/PDIF عدد 1 مقعد دخل S/PDIF (اختياري) عدد 1 وصلة مروحة وحدة المعالجة المركزية عدد 2 وصلة مروحة النظم عدد 1 وصلة مسح CMOS عدد 2 مقعد USB عدد 1 مقعد توصيل الطاقة (24دوس) عدد 1 مقعد توصيل الطاقة (4دبليس)	عدد 1 مقعد محرك أقراص مرنة عدد 1 مقعد طابعة عدد 1 مقعد IDE عدد 4 مقعد SATA عدد 1 مقعد اللوحة الأممية عدد 1 مقعد الصوت الأممي عدد 1 مقعد (اختياري) CD-IN عدد 1 مقعد خرج S/PDIF عدد 1 مقعد دخل S/PDIF (اختياري) عدد 1 وصلة مروحة وحدة المعالجة المركزية عدد 2 وصلة مروحة النظم عدد 1 وصلة مسح CMOS عدد 2 مقعد USB عدد 1 مقعد توصيل الطاقة (24دوس) عدد 1 مقعد توصيل الطاقة (4دبليس)	المنافذ على سطح اللوحة
عدد 1 لوحة مفاتيح PS2 عدد 1 مؤس PS/2 عدد 1 مقعد تسلسلي عدد 1 مقعد شبكة لتصل محلية عدد 6 منافذ USB عدد 3 مقيس صوت	عدد 1 لوحة مفاتيح PS2 عدد 1 مؤس PS/2 عدد 1 مقعد تسلسلي عدد 1 مقعد شبكة لتصل محلية عدد 6 منافذ USB عدد 6 مقيس صوت	منافذ دخل/خرج اللوحة الخلفية
220 مم (عرض) X 305 مم (ارتفاع)	220 مم (عرض) X 305 مم (ارتفاع)	حجم اللوحة
Windows 2000 / XP / VISTA بخطأ في إضفة أو إزالة الدعم لنظام تشغيل بإخطل أو Biostar تحتفظ بيون إخطل.	Windows 2000 / XP / VISTA بخطأ في إضفة أو إزالة الدعم لنظام تشغيل بإخطل أو Biostar تحتفظ بيون إخطل.	دعم أنظمة تشغيل

JAPANESE

	Ver 5.x	Ver 6.x
CPU	LGA 775 Intel Core2Duo / Core2Quad / Pentium 4 / Pentium D / Celeron D processor up to 3.8 GHz Hyper-Threading / Execute Disable Bit / Enhanced Intel SpeedStep® / Intel Architecture-64 / Extended Memory 64 Technology / Virtualization Technologyをサポート します	LGA 775 Intel Core2Duo / Core2Quad / Pentium 4 / Pentium D / Celeron D processor up to 3.8 GHz Hyper-Threading / Execute Disable Bit / Enhanced Intel SpeedStep® / Intel Architecture-64 / Extended Memory 64 Technology / Virtualization Technologyをサポート します
FSB	533 / 800 / 1066 MHz	533 / 800 / 1066 MHz
チップセット	Intel P965 Intel ICH8	Intel P965 Intel ICH8
メインメモリ	DDR2 DIMMスロット x 4 各DIMMは 256/512MB/1GB/2GB DDR2をサポート 最大メモリ容量8GB デュアルチャンネルモードDDR2メモリモジュール DDR2 533 / 667 / 800をサポート 登録済みDIMMとECC DIMMはサポートされません	DDR2 DIMMスロット x 4 各DIMMは 256/512MB/1GB/2GB DDR2をサポート 最大メモリ容量8GB デュアルチャンネルモードDDR2メモリモジュール DDR2 533 / 667 / 800をサポート 登録済みDIMMとECC DIMMはサポートされません
Super I/O	ITE 8712F もつとも一般に使用されるレガシーSuper I/O機能を 採用しています。 低ピンカウントインターフェイス 環境コントロールイニシアチブ、 H/Wモニター ファン速度コントローラ/ モニター ITEの「スマートガーディアン」機能	ITE 8712F もつとも一般に使用されるレガシーSuper I/O機能を 採用しています。 低ピンカウントインターフェイス 環境コントロールイニシアチブ、 H/Wモニター ファン速度コントローラ/ モニター ITEの「スマートガーディアン」機能
IDE	VIA VT6410 Ultra DMA 33 / 66 / 100 / 133バスマスタモード PIO Mode 0~4のサポート、	VIA VT6410 Ultra DMA 33 / 66 / 100 / 133バスマスタモード PIO Mode 0~4のサポート、
SATA II	統合シリアルATAコントローラ 最高3 Gb/秒のデータ転送速度 SATAバージョン2.0仕様に準拠。	統合シリアルATAコントローラ 最高3 Gb/秒のデータ転送速度 SATAバージョン2.0仕様に準拠。
LAN	Realtek RTL 8110SC 10 / 100 Mb/秒および1Gb/秒のオートネゴシエー ション 半/全二重機能	Realtek RTL 8110SC 10 / 100 Mb/秒および1Gb/秒のオートネゴシエー ション 半/全二重機能

	Ver 5.x		Ver 6.x	
HDオーディオのサポート	ALC888 Intelハイデフィニションオーディオのサポート 7.1チャンネルオーディオアウト		ALC861VD Intelハイデフィニションオーディオのサポート 5.1チャンネルオーディオアウト	
スロット	PCIスロット	x3	PCIスロット	x3
	PCI Express x16スロット	x1	PCI Express x16スロット	x1
	PCI Express x 4スロット	x1	PCI Express x 4スロット	x1
	PCI Express x 1スロット	x1	PCI Express x 1スロット	x1
オンボードコネクタ	フロッピーコネクタ	x1	フロッピーコネクタ	x1
	プリンタポートコネクタ	x1	プリンタポートコネクタ	x1
	IDEコネクタ	x1	IDEコネクタ	x1
	SATAコネクタ	x4	SATAコネクタ	x4
	フロントパネルコネクタ	x1	フロントパネルコネクタ	x1
	フロントオーディオコネクタ	x1	フロントオーディオコネクタ	x1
	CDインコネクタ(オプション)	x1	CDインコネクタ(オプション)	x1
	S/PDIFアウトコネクタ	x1	S/PDIFアウトコネクタ	x1
	S/PDIFインコネクタ(オプション)	x1	S/PDIFインコネクタ(オプション)	x1
	CPUファンヘッダ	x1	CPUファンヘッダ	x1
	システムファンヘッダ	x2	システムファンヘッダ	x2
	CMOSクリアヘッダ	x1	CMOSクリアヘッダ	x1
USBコネクタ	x2	USBコネクタ	x2	
電源コネクタ(24ピン)	x1	電源コネクタ(24ピン)	x1	
電源コネクタ(4ピン)	x1	電源コネクタ(4ピン)	x1	
背面パネル I/O	PS/2キーボード	x1	PS/2キーボード	x1
	PS/2マウス	x1	PS/2マウス	x1
	シリアルポート	x1	シリアルポート	x1
	LANポート	x1	LANポート	x1
	USBポート	x6	USBポート	x6
	オーディオジャック	x6	オーディオジャック	x3
ボードサイズ	220 mm (幅) X 305 mm (高さ)		220 mm (幅) X 305 mm (高さ)	
OSサポート	Windows 2000 / XP / VISTA Biostarは事前のサポートなしにOSサポートを追加または削除する権利を留保します。		Windows 2000 / XP / VISTA Biostarは事前のサポートなしにOSサポートを追加または削除する権利を留保します。	

2006/11/08

P965 775 BIOS Setup

BIOS Setup	1
1 Main Menu	3
2 Standard CMOS Features	7
3 Advanced BIOS Features	9
4 Advanced Chipset Features	16
5 Integrated Peripherals	18
6 Power Management Setup	23
7 PnP/PCI Configurations	29
8 PC Health Status	32
9 Performance Booster Zone	35

BIOS Setup

Introduction

The purpose of this manual is to describe the settings in the Award™ BIOS Setup program on this motherboard. The Setup program allows users to modify the basic system configuration and save these settings to CMOS RAM. The power of CMOS RAM is supplied by a battery so that it retains the Setup information when the power is turned off.

Basic Input-Output System (BIOS) determines what a computer can do without accessing programs from a disk. This system controls most of the input and output devices such as keyboard, mouse, serial ports and disk drives. BIOS activates at the first stage of the booting process, loading and executing the operating system. Some additional features, such as virus and password protection or chipset fine-tuning options are also included in BIOS.

The rest of this manual will to guide you through the options and settings in BIOS Setup.

Plug and Play Support

This AWARD BIOS supports the Plug and Play Version 1.0A specification and ESCD (Extended System Configuration Data) write.

EPA Green PC Support

This AWARD BIOS supports Version 1.03 of the EPA Green PC specification.

APM Support

This AWARD BIOS supports Version 1.1&1.2 of the Advanced Power Management (APM) specification. Power management features are implemented via the System Management Interrupt (SMI). Sleep and Suspend power management modes are supported. Power to the hard disk drives and video monitors can also be managed by this AWARD BIOS.

ACPI Support

Award ACPI BIOS support Version 1.0 of Advanced Configuration and Power interface specification (ACPI). It provides ASL code for power management and device configuration capabilities as defined in the ACPI specification, developed by Microsoft, Intel and Toshiba.

P965 775

PCI Bus Support

This AWARD BIOS also supports Version 2.1 of the Intel PCI (Peripheral Component Interconnect) local bus specification.

DRAM Support

DDR SDRAM (Double Data Rate Synchronous DRAM) is supported.

Supported CPUs

This AWARD BIOS supports the Intel CPU.

Using Setup

Use the arrow keys to highlight items in most of the place, press <Enter> to select, use the <PgUp> and <PgDn> keys to change entries, press <F1> for help and press <Esc> to quit. The following table provides more detail about how to navigate in the Setup program by using the keyboard.

Keystroke	Function
Up arrow	Move to previous item
Down arrow	Move to next item
Left arrow	Move to the item on the left (menu bar)
Right arrow	Move to the item on the right (menu bar)
Move Enter	Move to the item you desired
PgUp key	Increase the numeric value or make changes
PgDn key	Decrease the numeric value or make changes
+ Key	Increase the numeric value or make changes
- Key	Decrease the numeric value or make changes
Esc key	Main Menu – Quit and not save changes into CMOS Status Page Setup Menu and Option Page Setup Menu – Exit Current page and return to Main Menu
F1 key	General help on Setup navigation keys
F5 key	Load previous values from CMOS
F7 key	Load the optimized defaults
F10 key	Save all the CMOS changes and exit

1 Main Menu

Once you enter Award BIOS™ CMOS Setup Utility, the Main Menu will appear on the screen. The Main Menu allows you to select from several setup functions. Use the arrow keys to select among the items and press <Enter> to accept and enter the sub-menu.

!! WARNING !!

For better system performance, the BIOS firmware is being continuously updated. The BIOS information described in this manual (Figure 1, 2, 3, 4, 5, 6, 7, 8, 9) is for your reference only. The actual BIOS information and settings on board may be slightly different from this manual.

■ **Figure 1: Main Menu**

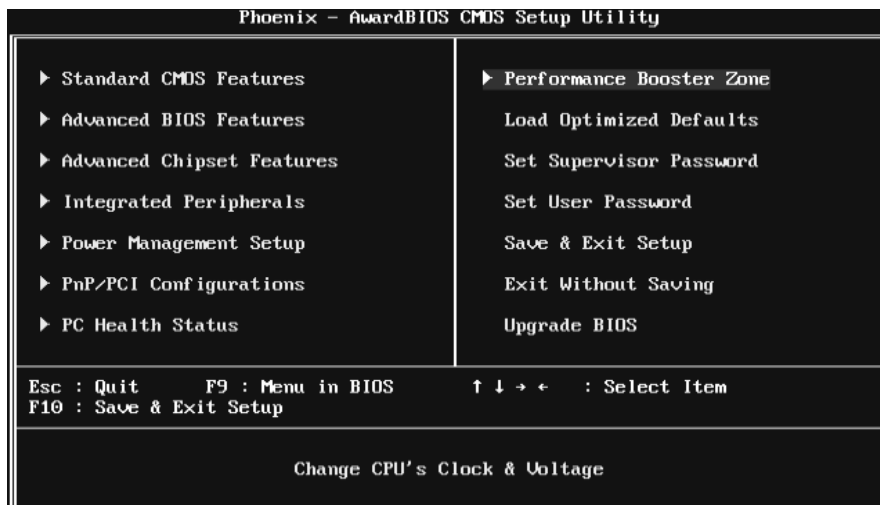

Standard CMOS Features

This submenu contains industry standard configurable options.

Advanced BIOS Features

This submenu allows you to configure advanced features of the BIOS.

P965 775

Advanced Chipset Features

This submenu allows you to configure special chipset features.

Integrated Peripherals

This submenu allows you to configure certain IDE hard drive options and Programmed Input/ Output features.

Power Management Setup

This submenu allows you to configure the power management features.

PnP/PCI Configurations

This submenu allows you to configure certain “Plug and Play” and PCI options.

PC Health Status

This submenu allows you to monitor the hardware of your system.

Performance Booster Zone

This submenu allows you to change CPU Vcore Voltage and CPU/PCI clock. (However, we suggest you to use the default setting. Changing the voltage and clock improperly may damage the CPU or M/B!)

Load Optimized Defaults

This selection allows you to reload the BIOS when problem occurs during system booting sequence. These configurations are factory settings optimized for this system. A confirmation message will be displayed before defaults are set.



Load Optimized Defaults (Y/N)? N

P965 775

Set Supervisor Password

Setting the supervisor password will prohibit everyone except the supervisor from making changes using the CMOS Setup Utility. You will be prompted with to enter a password.

```
Enter Password:
```

Set User Password

If the Supervisor Password is not set, then the User Password will function in the same way as the Supervisor Password. If the Supervisor Password is set and the User Password is set, the “User” will only be able to view configurations but will not be able to change them.

```
Enter Password:
```

Save & Exit Setup

Save all configuration changes to CMOS (memory) and exit setup. Confirmation message will be displayed before proceeding.

```
SAVE to CMOS and EXIT (Y/N)? Y
```

Exit Without Saving

Abandon all changes made during the current session and exit setup. Confirmation message will be displayed before proceeding.

```
Quit Without Saving (Y/N)? N
```

P965 775

Upgrade BIOS

This submenu allows you to upgrade bios.

BIOS UPDATE UTILITY (Y/N)? N

2 Standard CMOS Features

The items in Standard CMOS Setup Menu are divided into several categories. Each category includes no, one or more than one setup items. Use the arrow keys to highlight the item and then use the <PgUp> or <PgDn> keys to select the value you want in each item.

■ **Figure 2: Standard CMOS Setup**

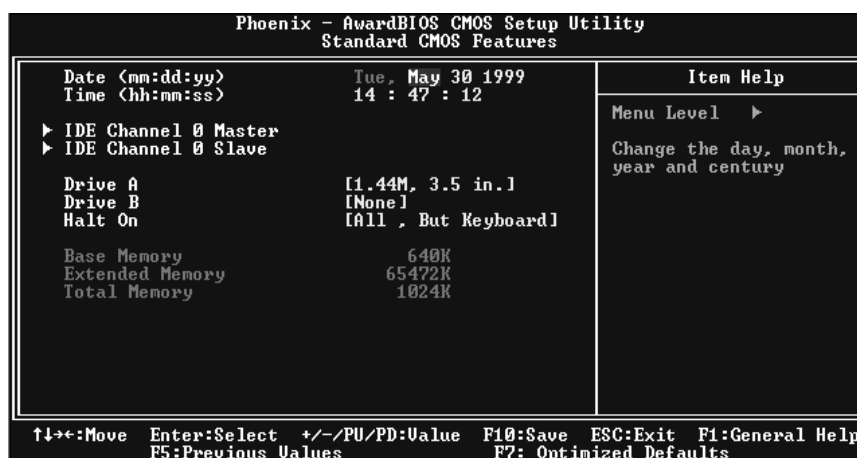

Main Menu Selections

This table shows the items and the available options on the Main Menu.

Item	Options	Description
Date	mm : dd : yy	Set the system date. Note that the 'Day' automatically changes when you set the date.
Time	hh : mm : ss	Set the system internal clock.
IDE Channel 0 Master	Options are in its sub menu.	Press <Enter> to enter the sub menu of detailed options
IDE Channel 0 Slave	Options are in its sub menu.	Press <Enter> to enter the sub menu of detailed options.
Drive A	360K, 5.25 in	Select the type of floppy disk drive installed in your system.
Drive B	1.2M, 5.25 in	

P965 775

Item	Options	Description
	720K, 3.5 in 1.44M, 3.5 in 2.88M, 3.5 in None	
Halt On	All Errors No Errors All, but Key board All, but Diskette All, but Disk/ Key	Select the situation in which you want the BIOS to stop the POST process and notify you.
Base Memory	N/A	Displays the amount of conventional memory detected during boot up.
Extended Memory	N/A	Displays the amount of extended memory detected during boot up.
Total Memory	N/A	Displays the total memory available in the system.

3 Advanced BIOS Features

■ Figure 3: Advanced BIOS Setup

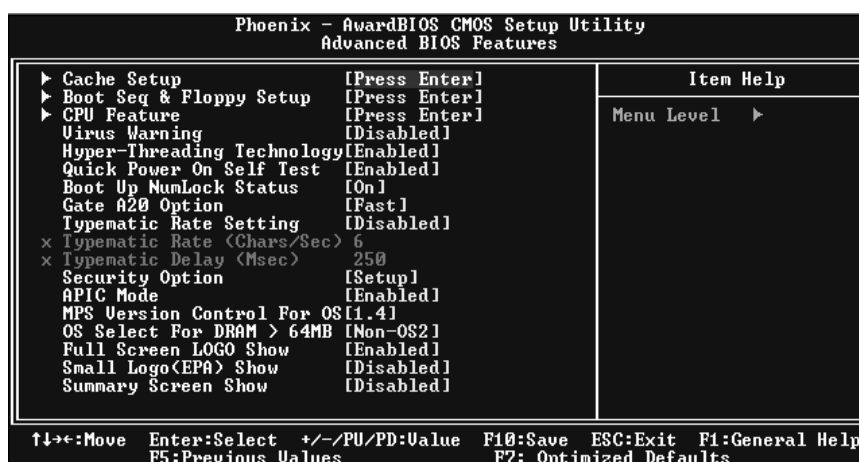

Cache Setup

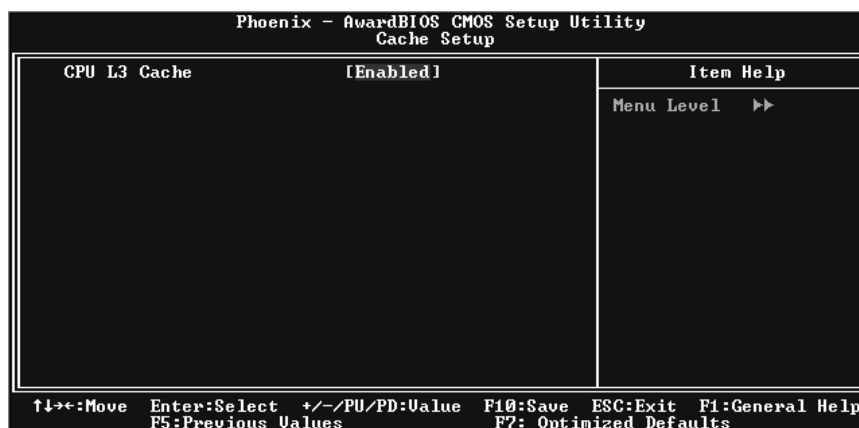

CPU L3 Cache

Depending on the CPU/chipset in use, you may be able to increase memory access time with this option.

- Enabled** (default) Enable cache.
- Disabled Disable cache.

P965 775

Boot Seq & Floppy Setup

This item allows you to setup boot sequence & Floppy.

```
Phoenix - AwardBIOS CMOS Setup Utility
Boot Seq & Floppy Setup

▶ Hard Disk Boot Priority [Press Enter]
  First Boot Device      [Floppy]
  Second Boot Device     [Hard Disk]
  Third Boot Device      [CDROM]
  Boot Other Device      [Enabled]

  Swap Floppy Drive      [Disabled]
  Boot Up Floppy Seek    [Enabled]
  Report No FDD For WIN 95 [No]

Item Help
Menu Level  ▶▶
Select Hard Disk Boot
Device Priority

↑↓←→:Move  Enter:Select  +/~/PU/PD:Ualue  F10:Save  ESC:Exit  F1:General Help
F5:Previous Values      F7: Optimized Defaults
```

Hard Disk Boot Priority

The BIOS will attempt to arrange the Hard Disk boot sequence automatically. You can change the Hard Disk booting sequence here.

```
Phoenix - AwardBIOS CMOS Setup Utility
Hard Disk Boot Priority

1. Pri.Master:
2. Pri.Slave :
3. Sec.Master:
4. Sec.Slave :
5. USBHDD0  :
6. USBHDD1  :
7. USBHDD2  :
8. Bootable Add-in Cards

Item Help
Menu Level  ▶▶▶▶
Use <↑> or <↓> to
select a device , then
press <+> to move it
up , or <-> to move it
down the list. Press
<ESC> to exit this
menu.

↑↓:Move  PU/PD/+/-:Change Priority  F10:Save  ESC:Exit
F5:Previous Values  F6:Fail-Safe Defaults  F7:Optimized Defaults
```

The Choices: Pri. Master, Pri. Slave, Sec. Master, Sec. Slave, USB HDD0, USB HDD1, USB HDD2, and Bootable Add-in Cards.

P965 775

First/Second/Third Boot Device

The BIOS will attempt to load the operating system in this order.

The Choices: Floppy, LS120, Hard Disk, CDROM, ZIP100, USB-FDD, USB-ZIP, USB-CDROM, LAN, Disabled.

Boot Other Device

When enabled, BIOS will try to load the operating system from other device when it failed to load from the three devices above.

The Choices: Enabled (default), Disabled

Swap Floppy Drive

For systems with two floppy drives, this option allows you to swap logical drive assignments.

The Choices: Disabled (default), Enabled.

Boot Up Floppy Seek

When enabled, System will test the floppy drives to determine if they have 40 or 80 tracks during boot up. Disabling this option reduces the time it takes to boot-up.

The Choices: Enabled (default), Disabled.

Report NO FDD for Win95

This item allows you to select YES/NO to Report NO FDD for Win95.

The Choices: NO (default), Yes.

CPU Feature

Phoenix - AwardBIOS CMOS Setup Utility		
CPU Feature		
Delay Prior to Thermal	[16 Min]	Item Help
Thermal Management	[Thermal Monitor 1]	
TM2 Bus Ratio	[0 X]	Menu Level >>
TM2 Bus UID	[0.83750]	
Limit CPUID MaxVal	[Disabled]	
C1E Function	[Auto]	
Execute Disable Bit	[Enabled]	
Virtualization Technology	[Enabled]	

F5: Previous Values F7: Optimized Defaults

P965 775

Delay Prior to Thermal

Set this item to enable the CPU Thermal function to engage after the specified time.

The Choices: 4 Min, 8 Min, **16Min** (default), 32 Min.

Thermal Management

This option allows you to select the way to control the “Thermal Management.”

The Choices: **Thermal Monitor 1** (default), Thermal Monitor 2.

TM2 Bus Ratio

This option represents the frequency (bus ratio) of the throttled performance state that will be initiated when the on-die sensor detects temperature increase.

Min= 0 Max= 255 Key in a DEC number.

The Choices: **0 X** (default)

TM2 Bus VID

This option represents the voltage of the throttled performance state that will be initiated when the on-die sensor detects temperature increase.

The Choices: **0.8375V** (default), 0.8375-1.6000.

Limit CUID MaxVal

Set Limit CUID MaxVal to 3, it should be “Disabled” for Windows XP.

The Choices: **Disabled** (default), Enabled.

C1E Function

This item allows you to configure the Enhanced Halt State (C1E) function, which may reduce the power consumption of your system when the system is idle.

The Choices: **Auto** (default), Disabled.

Execute Disable Bit

This item allows you to configure the Execute Disabled Bit function, which protects your system from buffer overflow attacks.

The Choices: **Enabled** (default), Disabled.

Virtualization Technology

Virtualization Technology can virtually separate your system resource into several parts, thus enhance the performance when running virtual machines or multi interface systems.

The Choices: **Enabled** (default), Disabled.

P965 775

Virus Warning

This option allows you to choose the VIRUS Warning feature that is used to protect the IDE Hard Disk boot sector. If this function is enabled and an attempt is made to write to the boot sector, BIOS will display a warning message on the screen and sound an alarm beep.

Disabled (default) Virus protection is disabled.

Enabled Virus protection is activated.

Hyper-Threading Technology

This option allows you to enable or disabled Hyper-Threading Technology. “Enabled” for Windows XP and Linux 2.4.x (OS optimized for Hyper-Threading Technology). “Disable” for other OS (OS not optimized for Hyper-Threading Technology).

The Choices: **Enabled** (default), Disabled.

Quick Power On Self Test

Enabling this option will cause an abridged version of the Power On SelfTest (POST) to execute after you power up the computer.

Disabled Normal POST.

Enabled (default) Enable quick POST.

Boot Up NumLock Status

Selects the NumLock State after the system switched on.

The Choices:

On (default) Numpad is number keys.

Off Numpad is arrow keys.

Gate A20 Option

Select if chipset or keyboard controller should control Gate A20.

Normal A pin in the keyboard controller controls GateA20.

Fast (default) Lets chipset control Gate A20.

Typematic Rate Setting

When a key is held down, the keystroke will repeat at a rate determined by the keyboard controller. When enabled, the typematic rate and typematic delay can be configured.

The Choices: **Disabled** (default), Enabled.

P965 775

Typematic Rate (Chars/Sec)

Sets the rate at which a keystroke is repeated when you hold the key down.

The Choices: 6 (default), 8, 10, 12, 15, 20, 24, 30.

Typematic Delay (Msec)

Sets the delay time after the key is held down before it begins to repeat the keystroke.

The Choices: 250 (default), 500, 750, 1000.

Security Option

This option will enable only individuals with passwords to bring the system online and/or to use the CMOS Setup Utility.

System: A password is required for the system to boot and is also required to access the Setup Utility.

Setup (default): A password is required to access the Setup Utility only.

This will only apply if passwords are set from the Setup main menu.

APIC MODE

Selecting Enabled enables APIC device mode reporting from the BIOS to the operating system.

The Choices: Enabled (default), Disabled.

MPS Version Control For OS

The BIOS supports version 1.1 and 1.4 of the Intel multiprocessor specification.

Select version supported by the operation system running on this computer.

The Choices: 1.4 (default), 1.1.

OS Select For DRAM > 64MB

A choice other than Non-OS2 is only used for OS2 systems with memory exceeding 64MB.

The Choices: Non-OS2 (default), OS2.

P965 775

Full Screen LOGO Show

This item allows you to enable/disable Full Screen LOGO Show.

The Choices: **Enabled** (default), Disabled.

Small Logo(EPA) Show

This item allows you to select whether the “Small Logo” shows.

The Choices: **Disabled** (default), Enabled.

Summary Screen Show

This item allows you to enable/disable the summary screen. Summary screen means system configuration and PCI device listing.

The Choices: **Disabled** (default), Enabled.

4 Advanced Chipset Features

This submenu allows you to configure the specific features of the chipset installed on your system. This chipset manage bus speeds and access to system memory resources, such as DRAM. It also coordinates communications with the PCI bus. The default settings that came with your system have been optimized and therefore should not be changed unless you are suspicious that the settings have been changed incorrectly.

■ **Figure 4: Advanced Chipset Setup**

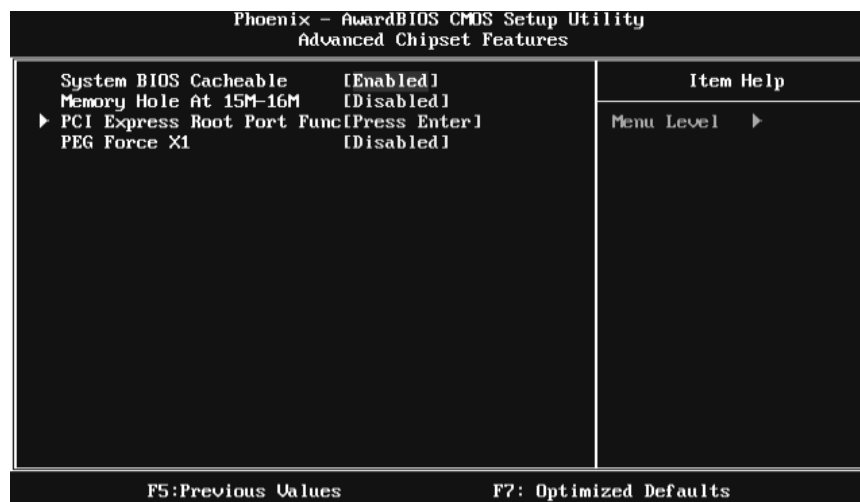

System BIOS Cacheable

Selecting the “Enabled” option allows caching of the system BIOS ROM at F0000h-FFFFFh, which is able to improve the system performance. However, any programs that attempts to write to this memory block will cause conflicts and result in system errors.

The Choices: Enabled (default), Disabled.

Memory Hole At 15M-16M

You can reserve this area of system memory for ISA adapter ROM. When this area is reserved it cannot be cached. Check the user information of peripherals that need to use this area of system memory for the memory requirements.

The Choices: Disabled (default), Enabled.

P965 775

PCI Express Root Port Func

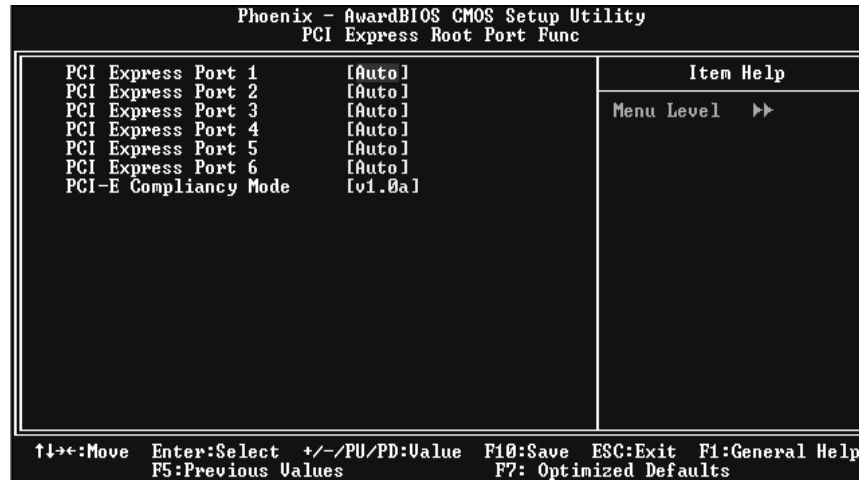

PCI Express Port 1/ 2 / 3/ 4/ 5/ 6

This item allows you to select the PCI Express Port.

The Choices: Auto (default), Enabled, Disabled.

PCI-E Compliancy Mode

This item allows you to select the PCI-E Compliancy Mode.

The Choices: v1.0a (default), v1.0.

PEG Force X1

When using on-chip VGA, this item has to be set as X1.

Disabled (default) PCI Express X16

Enabled PCI Express X1

5 Integrated Peripherals

■ Figure 5. Integrated Peripherals

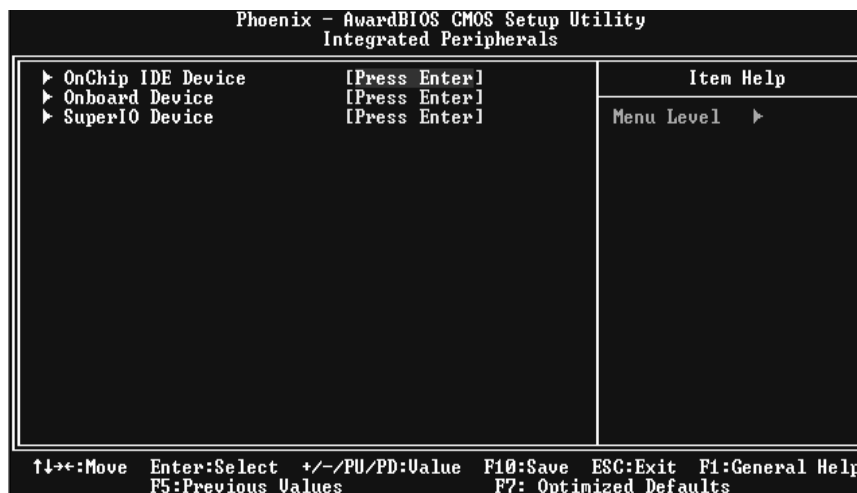

OnChip IDE Device

Highlight the “Press Enter” label next to the “OnChip IDE Device” label and press enter key will take you a submenu with the following options:

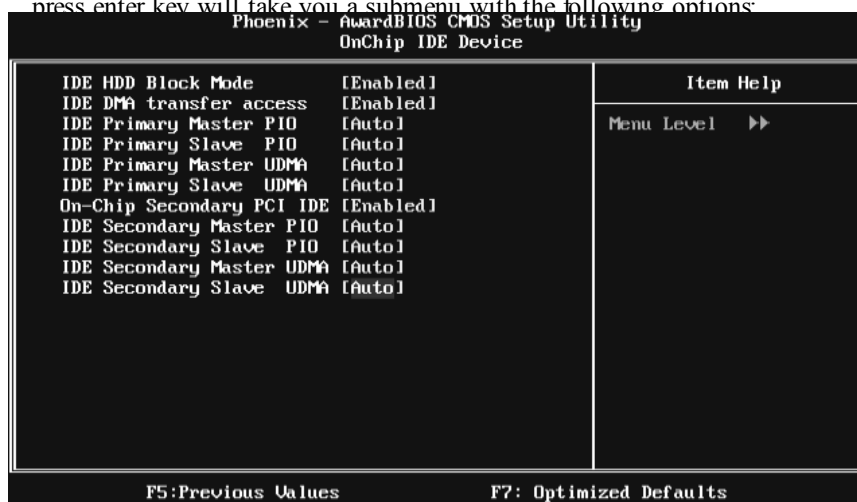

P965 775

IDE HDD Block Mode

Block mode is also called block transfer, multiple commands, or multiple sectors read / write. If your IDE hard drive supports block mode (most new drives do), select Enabled for automatic detection of the optimal number of block mode (most new drives do), select Enabled for automatic detection of the optimal number of block read / write per sector where the drive can support.

The Choices: Enabled (default), Disabled.

IDE DMA Transfer Access

This item allows you to enable or disable the IDE DMA transfer access.

The Choices: Enabled (default), Disabled.

IDE Primary/Secondary/Master/Slave PIO

The IDE PIO (Programmed Input / Output) fields let you set a PIO mode (0-4) for each of the IDE devices that the onboard IDE interface supports. Modes 0 to 4 will increase performance progressively. In Auto mode, the system automatically determines the best mode for each device.

The Choices: Auto (default), Mode0, Mode1, Mode2, Mode3, Mode4.

On-chip Secondary PCI IDE

This item allows you to enable or disable the primary / secondary IDE Channel.

The Choices: Enabled (Default), Disabled.

IDE Primary/Secondary/Master/Slave UDMA

Ultra DMA function can be implemented if it is supported by the IDE hard drives in your system. As well, your operating environment requires a DMA driver (Windows 95 or OSR2 may need a third party IDE bus master driver). If your hard drive and your system software both support Ultra DMA, select Auto to enable BIOS support.

The Choices: Auto (default), Disabled.

P965 775

Onboard Device

Highlight the “Press Enter” label next to the “Onboard Device” label and press the enter key will take you a submenu with the following options:



USB Controller

Select enabled if your system contains a Universal Serial Bus (USB) controller and you use USB peripherals.

The Choices: Enabled (default), Disabled

USB 2.0 Controller

This entry is to enable/ disabled EHCI controller.

The Choices: Enabled (default), Disabled.

USB Keyboard Support

This item allows you to enable or disable the USB Keyboard Legacy Support.

Enabled Enable USB Keyboard Support.

Disabled (default) Disable USB Keyboard Support.

USB Mouse Support

This item allows you to enable or disable the USB Mouse Legacy Support.

Enabled Enable USB Mouse Support.

Disabled (default) Disable USB Mouse Support.

P965 775

Onboard Azalia Audio

This item allows you to enable or disable to support Onboard Azalia Audio function.

The Choices: Auto (default), Disabled.

Onboard PATA IDE<VT6410>

The Choices: Enabled (default), Disabled

Onboard LAN

This item allows you to enable or disable the Onboard LAN.

The Choices: Enabled (default), Disabled.

Onboard LAN Boot ROM

This item allows you to enable or disable the Onboard LAN Boot ROM.

The Choices: Disabled (default), Enabled.

Super IO Device

Press Enter to configure the Super I/O Device.



Onboard FDC Controller

Select enabled if your system has a floppy disk controller (FDC) installed on the system board and you wish to use it. If you installed another FDC or the system uses no floppy drive, select disabled in this field.

The Choices: Enabled (default), Disabled.

P965 775

Onboard Serial Port 1

Select an address and corresponding interrupt for the first and second serial ports.

The Choices: 3F8/IRQ4 (default), Disabled, 2F8/IRQ3, 3E8/IRQ4, 2E8/IRQ3, Auto.

Onboard Parallel Port

This item allows you to determine access onboard parallel port controller with which I/O Address.

The Choices: 378/IRQ7 (default), 278/IRQ5, 3BC/IRQ7, Disabled.

Parallel Port Mode

This item allows you to determine how the parallel port should function. The default value is SPP.

The Choices:

SPP (default)	Using Parallel port as Standard Printer Port.
EPP	Using Parallel Port as Enhanced Parallel Port.
ECP	Using Parallel port as Extended Capabilities Port.
ECP+EPP	Using Parallel port as ECP & EPP mode.

ECP Mode Use DMA

Select a DMA Channel for the port.

The Choices: 3 (default), 1.

6 Power Management Setup

The Power Management Setup Menu allows you to configure your system to utilize energy conservation and power up/power down features.

■ **Figure 6. Power Management Setup**

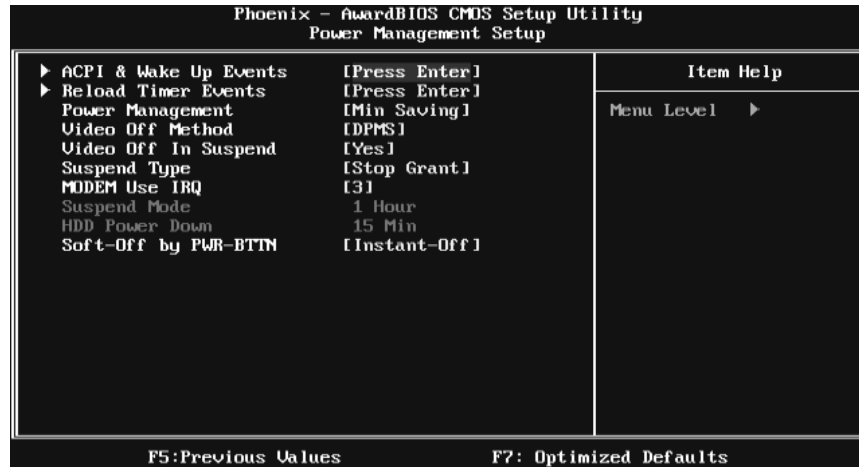

ACPI & Wake Up Events

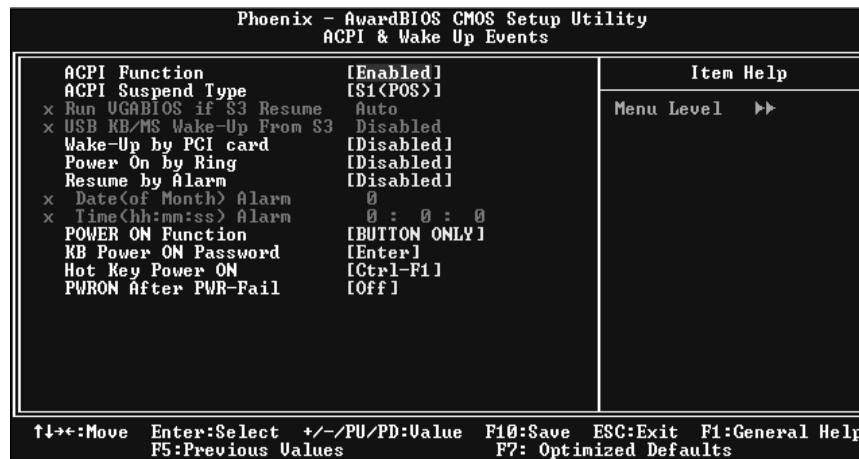

P965 775

ACPI Function

This item displays the status of the Advanced Configuration and Power Management (ACPI).

The Choices: Enabled (default), Disabled.

ACPI Suspend Type

The item allows you to select the suspend type under the ACPI operating system.

The Choices: S1 (POS) (default) Poweron Suspend
S3 (STR) Suspend to RAM
S1 & S3 POS+STR

Run VGABIOS if S3 Resume

Choosing Enabled will make BIOS run VGA BIOS to initialize the VGA card when system wakes up from S3 state. The system resume time is shortened if you disable the function, but system will need AGP driver to initialize the card. So, if the AGP driver of the VGA card does not support the initialization feature, the display may work abnormally or not function after S3.

The Choices: Auto (default), Yes, No.

USB KB/MS Wake-Up From S3

This item allows you to enable or disabled the USB keyboard wake up from S3 function.

The Choices: Disabled (default), Enabled.

Wake-Up by PCI card

When you select "Enable", a PME signal from PCI card returns the system to Full On state.

The Choices: Enabled, Disabled (default).

Power On by Ring

An input signal on the serial Ring Indicator (RI) line (in other words, an incoming call on the modem) awakens the system from a soft off state.

The Choices: Enabled, Disabled (default).

Resume by Alarm

This function is for setting date and time for your computer to boot up. When enabled, you can choose the date and time of system resume.

The Choices: Disabled (default), Enabled.

Date (of Month) Alarm

You can choose which month the system will boot up.

P965 775

Time (hh:mm:ss) Alarm

You can choose the system boot up time, input hour, minute and second to specify.

Note: If you have change the setting, you must let the system boot into operating system, before this function will work.

POWER ON Function

This item allows you to choose the power on method.

The Choices: **Button Only** (default), Password, Hot Key, Mouse Move/Click, Mouse Double Click, Any Key, Keyboard 98.

KB Power ON Password

Input password and press Enter to set the Keyboard power on password.

Hot Key Power ON

Choose the Hot Key combination to boot up the system.

The Choices: **Ctrl-F1** (default), Ctrl-F2, Ctrl-F3, Ctrl-F4, Ctrl-F5, Ctrl-F6, Ctrl-F7, Ctrl-F8, Ctrl-F9, Ctrl-F10, Ctrl-F11, and Ctrl-F12.

PWRON After PWR-Fail

This setting specifies how your system should behave after a power fail or interrupts occurs. By choosing off will leave the computer in the power off state. Choosing On will reboot the computer. Former-Sts will restore the system to the status before power failure or interrupt occurs.

The Choices: **Off** (default), On, Former-Sts.

Reload Timer Events

```
Phoenix - AwardBIOS CMOS Setup Utility
Reload Timer Events

Primary IDE 0      [Disabled]
Primary IDE 1      [Disabled]
Secondary IDE 0    [Disabled]
Secondary IDE 1    [Disabled]
FDD.COM_LPT Port  [Disabled]
PCI_PIRQ[A-D]#    [Disabled]

Item Help
Menu Level  >>

↑↓←→:Move  Enter:Select  +/-/PU/PD:Ualue  F10:Save  ESC:Exit  F1:General Help
F5:Previous Values  F7: Optimized Defaults
```

P965 775

Primary/Secondary IDE 0/1

You can enable or disable Primary or Secondary RAID 0 or RAID 1 function under this item.

The Choices: Disabled (default), Enabled.

FDD, COM, LPT Port

You can enable or disable FDD, COM, and LPT port under this item.

The Choices: Disabled (default), Enabled.

PCI PIRQ [A-D]#

You can enable or disable PCIPIRQ [A-D]# under this item.

The Choices: Disabled (default), Enabled.

Power Management

This category allows you to select the power saving method and is directly related to the following modes:

1. HDD Power Down.
2. Suspend Mode.

There are three options of Power Management, three of which have fixed mode settings

Min. Saving (default)

Minimum power management.

Suspend Mode = 1 hr.

HDD Power Down = 15 min

Max. Saving

Maximum power management only available for sl CPU's.

Suspend Mode = 1 min.

HDD Power Down = 1 min.

User Define

Allow you to set each option individually.

When you choose user define, you can adjust each of the item from 1 min. to 1 hr. except for HDD Power Down which ranges from 1 min. to 15 min.

P965 775

Video Off Method

This option determines the manner when the monitor goes blank.

V/H SYNC+Blank

This selection will cause the system to turn off the vertical and horizontal synchronization ports and write blanks to the video buffer.

Blank Screen

This option only writes blanks to the video buffer.

DPMS (default)

Initial display power management signaling.

Video Off In Suspend

This item determines the monitor status when the system is in Suspend mode.

The Choices: Yes (default), No.

Suspend Type

Select the Suspend Type.

The Choices: **Stop Grant** (default), PwrOn Suspend.

Modem Use IRQ

This determines the IRQ, which can be applied in MODEM use.

The Choices: **3** (default), 4, 5, 7, 9, 10, 11, NA.

Suspend Mode

The item allows you to adjust the system idle time before suspend.

The Choices: Disabled, 1 Min, 2 Min, 4 Min, 6 Min, 8 Min, 10 Min, 20 Min, 30 Min, 40 Min, **1 Hour** (default).

HDD Power Down

When enabled, the hard-disk drives will power down after a set time of system inactivity. All other devices remain active.

The Choices: Disabled, 1 Min, 2 Min, 3 Min, 4 Min, 5 Min, 6 Min, 7 Min, 8 Min, 9 Min, 10 Min, 11 Min, 12 Min, 13 Min, 14 Min, **15 Min** (default).

P965 775

Soft-Off by PWR-BTN

This item determines the behavior of system power button. Instant off turn off the power immediately, and Delay 4 Sec. will require you to press and hold the power button for 4 seconds to cut off the system power.

The Choices: Delay 4 Sec, **Instant-Off** (default).

7 PnP/PCI Configurations

This section describes configuring the PCI bus system. PCI, or Personal Computer Interconnect, is a system which allows I/O devices to operate at speeds nearing the speed of the CPU itself uses when communicating with its own special components. This section covers some very technical items and it is strongly recommended that only experienced users should make any changes to the default settings.

■ Figure 7: PnP/PCI Configurations

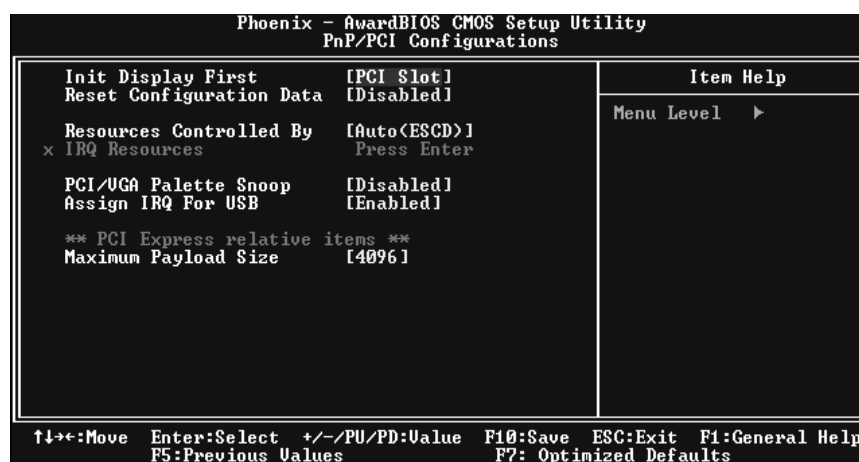

Init Display First

This item allows you to decide to active whether PCI Slot or on-chip VGA first.
The Choices: PCI Slot (default), Onboard, PCIEx.

Reset Configuration Data

The system BIOS supports the PnP feature which requires the system to record which resources are assigned and protects resources from conflict. Every peripheral device has a node, which is called ESCD. This node records which resources are assigned to it. The system needs to record and update ESCD to the memory locations. These locations are reserved in the system BIOS. If the Disabled (default) option is chosen, the system's ESCD will update only when the new configuration varies from the last one. If the Enabled option is chosen, the system is forced to update ESCDs and then is automatically set to the "Disabled" mode.

P965 775

The above settings will be shown on the screen only if “Manual” is chosen for the resources controlled by function.

Legacy is the term, which signifies that a resource is assigned to the ISA Bus and provides non-PnP ISA add-on cards. PCI / ISA PnP signify that a resource is assigned to the PCI Bus or provides for ISA PnP add-on cards and peripherals.

The Choices: Disabled (default), Enabled.

Resources Controlled By

By Choosing “Auto(ESCD)” (default), the system BIOS will detect the system resources and automatically assign the relative IRQ and DMA channel for each peripheral. By Choosing “Manual”, the user will need to assign IRQ & DMA for add-on cards. Be sure that there are no IRQ/DMA and I/O port conflicts.

The Choices: Auto (ESCD) (default), Manual.

IRQ Resources

This submenu will allow you to assign each system interrupt a type, depending on the type of device using the interrupt. When you press the “Press Enter” tag, you will be directed to a submenu that will allow you to configure the system interrupts. This is only configurable when “Resources Controlled By” is set to “Manual”.

IRQ-3	assigned to PCI Device
IRQ-4	assigned to PCI Device
IRQ-5	assigned to PCI Device
IRQ-7	assigned to PCI Device
IRQ-9	assigned to PCI Device
IRQ-10	assigned to PCI Device
IRQ-11	assigned to PCI Device
IRQ-12	assigned to PCI Device
IRQ-14	assigned to PCI Device
IRQ-15	assigned to PCI Device

PCI / VGA Palette Snoop

Some old graphic controllers need to “snoop” on the VGA palette and then map it to their display as a way to provide boot information and VGA compatibility. This item allows such snooping to take place.

The Choices: Disabled (default), Enabled

P965 775

Assign IRQ For USB

This item allows the users to choose which IRQ to assign for the USB.

The Choices: Enabled (default), Disabled.

Maximum Payload Size

Set the maximum payload size for Transaction packets (TLP).

The Choice: 4096 (default.), 128, 256, 512, 1024, 2048.

8 PC Health Status

■ Figure 8: PC Health Status

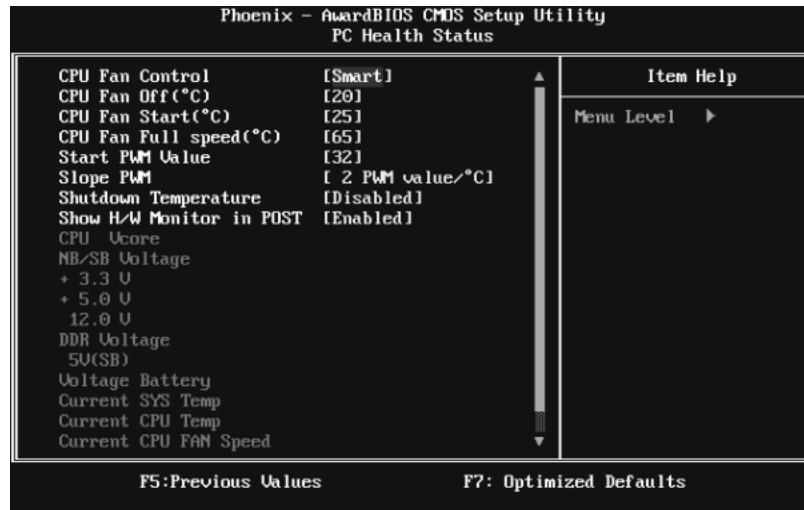

CPU FAN Control

Choose “smart” to reduce the noise caused by CPU FAN.

The Choices: Smart (default), Always On.

CPU Fan Off<°C>

If the CPU Temperature is lower than the set value, FAN will turn off

The Choices: Min=0 Max=127 Key in a DEC number.

CPU Fan Start<°C>

CPU fan starts to work under smart fan function when arrive this set value.

The Choices: Min=0 Max=127 Key in a DEC number.

P965 775

CPU Fan Full speed <°C >

When CPU temperature is reach the set value, the CPU fan will work under Full Speed.

The Choices: Min=0 Max=127 Key in a DEC number.

Start PWM Value

When CPU temperature arrives to the set value, the CPU fan will work under Smart Fan Function mode. The range is from 0~127, with an interval of 1.

The Choices: Min=0 Max=127 Key in a DEC number.

Slope PWM

Increasing the value of slope PWM will raise the speed of CPU fan.

The Choices: 1 PWM Value/°C (default), 2 PWM Value/°C, 4 PWM Value/°C, 8 PWM Value/°C, 16 PWM Value/°C.

Shutdown Temperature

This item allows you to set up the CPU shutdown Temperature. This item is only effective under Windows 98 ACPI mode.

The Choices: Disabled (default) , 65°C / 140°F, 70°C / 149°F, 75°C / 158°F.

Show H/W Monitor in POST

If you computer contains a monitoring system, it will show PC health status during POST stage. The item offers several different delay times.

The Choices: Enabled (default), Disabled.

CPU Vcore, NB/SB/DDR Voltage, +3.3V, +5.0V, 12.0V, 5V (SB), Voltage Battery

Detect the system's voltage status automatically.

Current SYS Temp

This field displays the current temperature of system.

P965 775

Current CPU Temp

This field displays the current temperature of CPU.

Current CPU FAN Speed

This field displays the current speed of CPU fan.

Current SYS FAN Speed

This field displays the current speed of SYSTEM fan.

Current JNFAN1 Speed

This field displays the current speed of JNFAN1 (North bridge) fan.

9 Performance Booster Zone

■ Figure 9: Performance Booster Zone

Phoenix - AwardBIOS CMOS Setup Utility		Item Help
Performance Booster Zone		Menu Level ▶
CPU Voltage	[StartUp]	
FSB Termination Voltage	[1.2 V]	
(G)MCH Voltage	[1.25 V]	
Memory Voltage	[1.8 V]	
DRAM Timing Selectable	[By SPD]	
System Memory Frequency	[Auto]	
CAS Latency Time	[Auto]	
DRAM RAS# to CAS# Delay	[Auto]	
DRAM RAS# Precharge	[Auto]	
Precharge delay (tRAS)	[Auto]	
TWR	[Auto]	
TWTR	[Auto]	
TRRD	[Auto]	
TRTP	[Auto]	
CPU Clock Ratio	[8 X]	
CPU Clock	[100MHz]	
PCIE Clock select	[Auto]	
x PCIE clock	100	

F5: Previous Values F7: Optimized Defaults

CPU Voltage

This item allows you to select CPU Voltage Control.
The Choices: StartUp (default), +0.012V~+0.787V.

FSB Termination Voltage

The Choices: 1.2V (default), 1.3V, 1.4V, 1.5V.

(G)MCH Voltage

The Choices: 1.25V (default), 1.35V, 1.45V, 1.55V.

Memory Voltage

The Choices: 1.8V (default), 1.9V, 2.0V, 2.1V.

P965 775

DRAM Timing Selectable

The Choices: By SPD (Default), Manual.

System Memory Frequency

The Choices: Auto (default), 533MHz, 667MHz, 800MHz.

CAS Latency Time

The Choices: Auto (Default), 3, 4, 5, 6.

DRAM RAS# to CAS# Delay

The Choices: Auto (Default), 3, 4, 5, 6, 7.

DRAM RAS# Precharge

The Choices: Auto (Default), 3, 4, 5, 6, 7.

Precharge delay <tRAS>

The Choices: Auto (Default), 9, 10, 11, 12, 13, 14, 15, 16, 17, 18, 19, 20, 21, 22, 23.

TWR

The Choices: Auto (Default), 3, 4, 5, 6, 7, 8, 9, 10, 11, 12, 13, 14, 15.

TWTR

The Choices: Auto (Default), 2, 3, 4, 5, 6, 7, 8, 9, 10, 11, 12, 13, 14, 15.

TRRD

The Choices: Auto (Default), 2, 3, 4, 5, 6, 7, 8, 9, 10, 11, 12, 13, 14, 15.

TRTP

The Choices: Auto (Default), 2, 3, 4, 5, 6, 7, 8, 9, 10, 11, 12, 13, 14, 15.

P965 775

CPU Clock Ratio

The Choices: 8X(default).
Min=8 Max=50 Key in a DEC number.

CPU Clock

The Choices: 100MHz(default).
Min=100 Max=333 Key in a DEC number.

PCIE Clock select

The Choices: Auto (default), Upto CPU, Fixed 100, Manual

PCIE Clock

Display the PCIE Clock frequency; Min=100, Max=200, key in a DEC number.