

P4TSG Pro

FCC Information and Copyright

This equipment has been tested and found to comply with the limits of a Class B digital device, pursuant to Part 15 of the FCC Rules. These limits are designed to provide reasonable protection against harmful interference in a residential installation. This equipment generates, uses and can radiate radio frequency energy and, if not installed and used in accordance with the instructions, may cause harmful interference to radio communications. There is no guarantee that interference will not occur in a particular installation.

The vendor makes no representations or warranties with respect to the contents here of and specially disclaims any implied warranties of merchantability or fitness for any purpose. Further the vendor reserves the right to revise this publication and to make changes to the contents here of without obligation to notify any party beforehand. Duplication of this publication, in part or in whole, is not allowed without first obtaining the vendor's approval in writing.

The content of this user's manual is subject to be changed without notice and we will not be responsible for any mistakes found in this user's manual. All the brand and product names are trademarks of their respective companies.

Content

LAYOUT OF P4TSG PRO	1
COMPONENT INDEX.....	2
ENGLISH.....	3
P4TSG Pro Features.....	3
Package contents.....	5
CPU Installation.....	6
DDR DIMM Modules: DDRA1-2, DDRB1-2.....	7
Installing Wireless LAN Card.....	8
Installing DDR Module.....	9
Jumpers, Headers, Connectors & Slots.....	10
STUDIOFUN!.....	16
Introduction.....	16
Hardware Requirements.....	16
Installation Procedure.....	16
Booting to StudioFun!.....	18
Media control.....	19
Control Panel.....	20
Software Details.....	22
Select Region.....	24
Screensaver.....	25
Display Settings.....	26
File Manager.....	27
WARPSPEEDER.....	29
Introduction.....	29
System Requirement.....	29
Installation.....	30
Usage.....	31
TROUBLE SHOOTING.....	39

Layout of P4TSG Pro

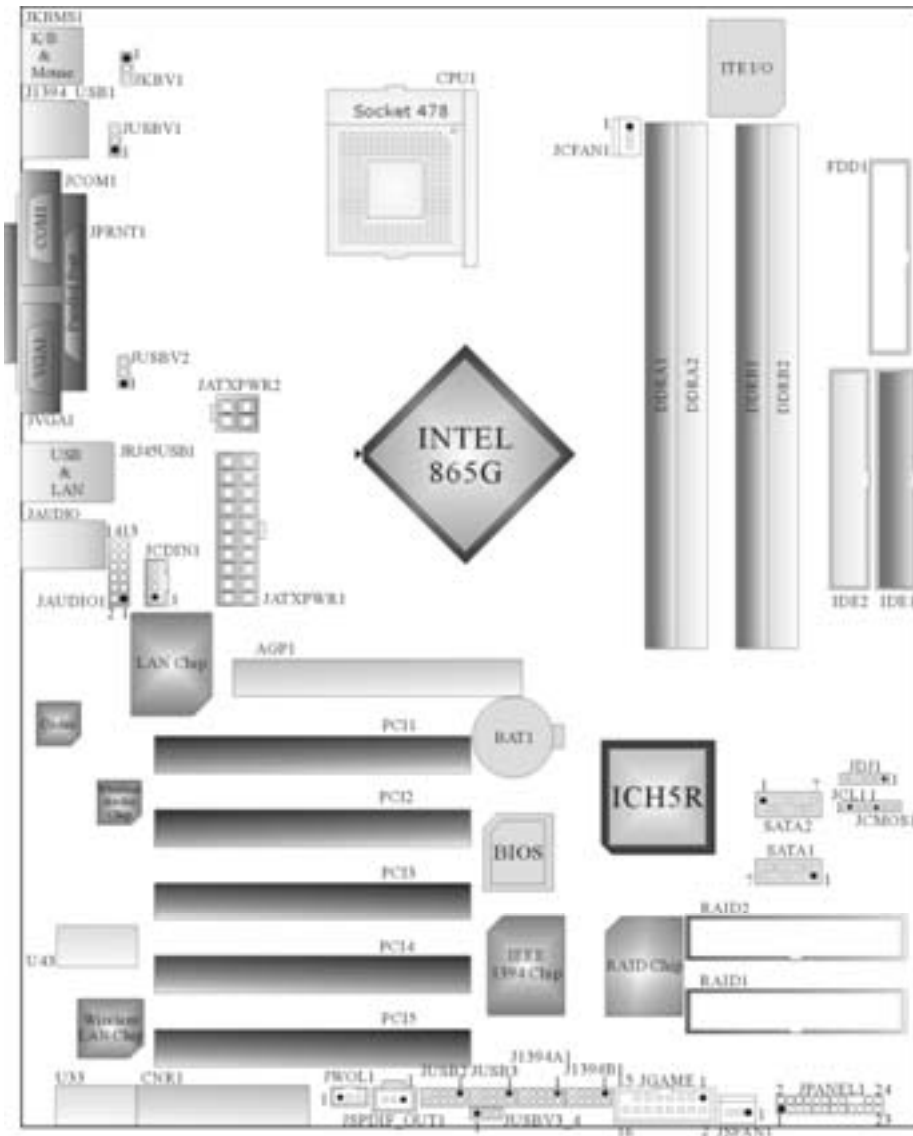

NOTE: ● represents the first pin.

Component Index

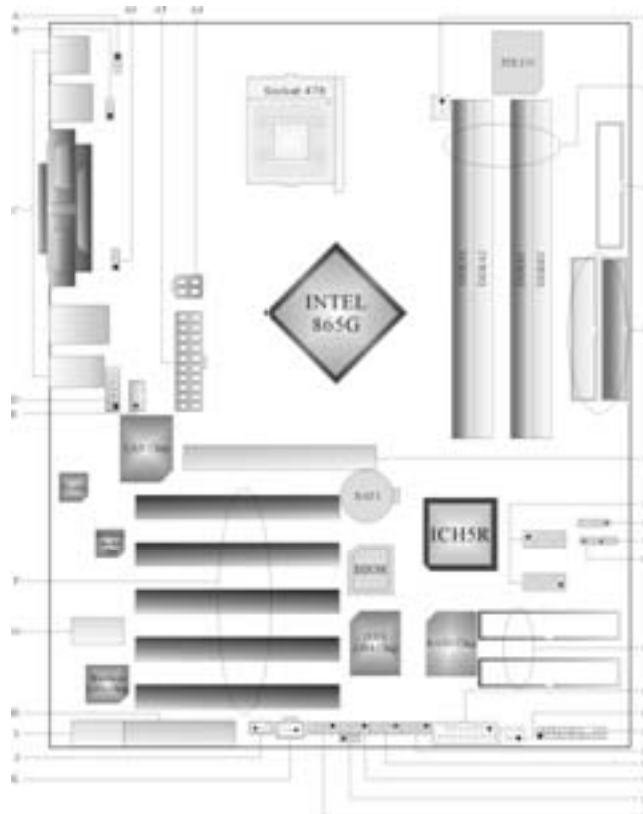

- | | |
|---|--|
| A. JK BV1: 5V/5VSB Selection for KB/MS | Q. JPANEL 1: Front Panel Connector |
| B. JUSBV1: 5V/5VSB Selection for JUSB1 | R. JSFAN1: System Fan Header |
| C. Back Panel Connectors | S. JGAME1: Game Header |
| D. JAUDIO1: Front Audio Header | T. RAID1-2: Raid Connectors |
| E. JCDIN1: CD-ROM Audio-In Header | U. JCL1: Case Open Connector |
| F. PCI-5: Peripheral Component Interconnect Slots | V. JCMOS1: Clear CMOS Jumper |
| G. U43: Wireless Audio Connector | W. JDJ1: Audio DJ Connector |
| H. CNR1: Communication Network Riser Slot | X. SAT A1-2: Serial ATA Connectors |
| I. U33: Wireless LAN Connector | Y. AGP1: Accelerated Graphic Port Slot |
| J. JWOL1: Wake On LAN Header | Z. IDE1-2: Hard Disk Connectors |
| K. JSPDIF_OUT1: Digital Audio Connector | A1. FDD1: Floppy Disk Connector |
| L. JUSB2: Front USB Header | A2. DDRA1-2/DDR B1-2: DDR DIMM Modules |
| M. JUSBV3_4: 5V/5VSB Selection for USB | A3. JCFAN1: CPU Fan Connector |
| N. JUSB3: Front USB Header | A4. JATXPWR2: ATX Power Connector |
| O. J1394A1: Front 1394 Header | A5. JATXPWR1: ATX Power Connector |
| P. J1394B1: Front 1394 Header | A6. JUSBV2: 5V/5VSB Selection for USB |

English

P4TSG Pro Features

A. Hardware

CPU

- Provides Socket-478.
- Supports the Intel Pentium 4 processor up to 3.06GHz.
- Front Side Bus at 400/533/800MHz.
- Supports Hyper-Threading.
- Supports Northwood and Prescott CPU. (Willamette not supported)

Chipset

- North Bridge: Intel 865G.
- South Bridge: Intel ICH5R.

Main Memory

- Supports one or two 64-bit wide DDR data channels with 1 or 2 DIMMs per-channel.
- Available bandwidth up to 3.2GB/s(DDR400) or single-channel mode and 6.4GB/s (DDR 400) in dual channel mode.
- Supports 128-Mb, 256-Mb, 512-Mb and 1-Gb DDR technologies.
- Supports only x8, x16, DDR devices. (Does not support registered DIMMs or double sided X 16 DIMMs)
- Supports four bank devices.
- Maximum memory size is 4GB.

Super I/O

- Chip: ITE IT8712.
- Low Pin Count Interface.
- Provides the most commonly used legacy Super I/O functionality.
- Environment Control initiatives,
 - H/W Monitor
 - Fan Speed Controller
 - ITE's "Smart Guardian" function

Slots

- Five 32-bit PCI bus master slots.
- One CNR slot.
- One AGP 4X/8X slot.
- One Wireless LAN slot.

On Board IDE

- Supports four IDE disk drives.
- Supports PIO Mode 5, Bridge Mode and Ultra DMA 33/66/100 Bus Master Mode.

-
-
- Supports 2 Serial ATA (SATA) ports.
 - Compliant with SATA 1.0 specification
 - Data transfer rates up to 1.5 GB/s

IEEE 1394 Chip

- Chip: VIA VT6307.
- Support 2 ports with transfer up to 400Mb/s.

Wireless LAN – Air Link™

- Chip: RTL8180L.
- Full compliance with IEEE802.11 and IEEE802.11b specifications.
- Supports Advanced Configuration Power management Interface (ACPI) and PCI power management system for modern operating systems.
- Supports remote wake-up in both ACPI and APM environments.
- Keeps network maintenance costs low and eliminates usage barriers.
- Uses one RF card for Wireless LAN.

LAN

- Chip: RTL8100B.
- Supports 10 Mb/s and 100 Mb/ auto-negotiation
- Half/Full duplex capability.
- Supports ACPI power management

On Board AC'97 Sound Codec

- Chip: CMI9739A/ 9760.
- Compliant with AC'97 specification.
- AC97 2.2 interface.
- Supports 6 channels.

On Board Peripherals

a. Rearside

- 1 serial port.
- 1 parallel port. (SPP/EPP/ECP mode)
- 1 VGA port.
- Audio ports in vertical position.
- 1 RJ-45 LAN jack.
- Supports PS/2 mouse and PS/2 key board.
- 4 USB2.0 ports.
- 1 1394 port.

b. FrontSide

- 1 floppy port supports 2 FDDs with 360K, 720K, 1.2M, 1.44M and 2.88Mbytes.
- 4 USB2.0 ports.
- 1 front audio.

Dimensions

- Micro ATX Form Factor: 30.5 X 24.4cm (W X L)
-
-

B. BIOS & Software

BIOS

- Award legal BIOS.
- Supports APM1.2.
- Supports ACPI.
- Supports USB Function.

Software

- Supports Warpspeeder™, 9th Touch™, FLASHER™, Watchdog™, StudioFun!™.
- Offers the highest performance for Windows 98 SE, Windows 2000, Windows Me, Windows XP, SCO UNIX, linux, etc.

Package contents

- HDD Cable X 2
- FDD Cable X1
- User's Manual X1
- Fully Setup Driver CD X1
- StudioFun! Application CD X1
- USB 2.0 Cable X1 (optional)
- S/PDIF Cable X 1 (optional)
- Rear I/O Panel or Micro ATX Case X1 (optional)
- Serial ATA Cable X1
- Serial ATA Power Switch Cable X1
- IEEE 1394 Cable X1 (optional)
- RF Module Riser Card

How to set up Jumper

The illustration shows how to set up jumper. When the Jumper cap is placed on pins, the jumper is "close". If no jumper cap is placed on the pins, the jumper is "open". The illustration shows a 3-pin jumper whose pin 1 and 2 are "close" when jumper cap is placed on these 2 pins.



Jumper open



Jumper close

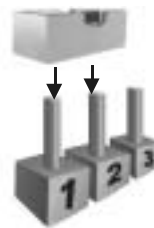

Pin1-2 close

CPU Installation

Step1: Pull the lever sideways away from the socket and then raise the lever up to a 90-degree angle.

Step2: Look for the white dot/cut edge. The white dot/cut edge should point towards the lever pivot. The CPU will fit only in the correct orientation.

Step3: Hold the CPU down firmly, and then close the lever to complete the installation.

Step4: Put the CPU Fan on the CPU and buckle it. Connect the CPU fan power cable to the JCFAN1. This completes the installation.

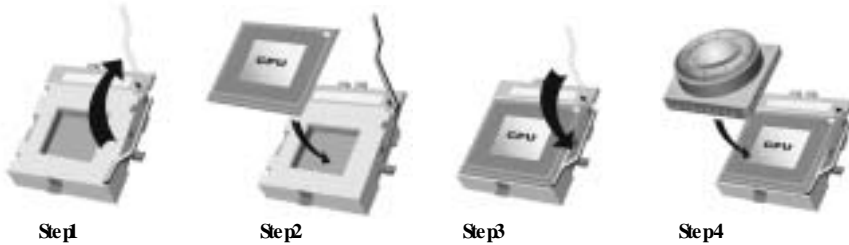

CPU Fan Headers: JCFAN1

 JCFAN1	1	Pin	Assignment
		1	Ground
		2	+12V
		3	FAN RPM Sense

System Fan Headers: JSFAN1

 JSFAN1	1	Pin	Assignment
		1	Ground
		2	+12V
		3	FAN RPM Sense

DDR DIMM Modules: DDRA1-2, DDRB1-2

■ Supports up to four DDR DIMMs (two DIMMs per channel), single-sided and/ or double-sided.

■ For Dual Channel Operation, DIMMs must be populated in identical pairs. It has to be the combination of DDRA1+DDR B1 (Blue DIMMs) or DDRA2+DDR B2 (white DIMMs).

■ *Dual Channel Guidelines*

Matched DIMM configuration in each channel

- Same Density (128MB, 256MB, 512MB, 1GB, etc.)
- Same DRAM technology (128M-bit, 256M-bit, or 512M-bit)
- Same DRAM bus width (x8 or x16)
- Both either single-sided or dual-sided

Matched in both Channel A and Channel B memory channels

- Populate symmetrical memory slots

Optimal platform performance with Dual Channel, DDR400, matched DIMMs

- Fully loaded configurations can be single or double sided DIMMs
- Lightly loaded configurations need to be double sided DIMMs

When not using DDR400, best performance obtained with

- Symmetrical DIMM population and matched double-sided DIMMs
- Lightly loaded configuration

■ Dual Channel Configuration Table

- Dual Channel Configuration Table

DIMM Slot	DDRA1	DDRA2	DDRB1	DDRB2	System Density
Lightly Loaded	128MB --		128MB --		256MB --
Config	1GB		1GB		2GB
Lightly Loaded		128MB --		128MB --	256MB --
Config		1GB		1GB	2GB
Fully Loaded	128MB --	128MB --	128MB --	128MB --	512MB --
Config	1GB	1GB	1GB	1GB	4GB

DRAM Access Time: 2.5V Unbuffered/ no registered (without ECC) DDR SDRAM
PC2100/ PC2700/ PC3200 Type required.

DRAM Type: 128MB/ 256MB/ 512MB/ 1GB DIMM Module (184 pin)

Installing Wireless LAN Card

1. Align the wireless LAN on the slot so that the wireless LAN card matches in the slot. Be sure to face the wireless LAN card with its components towards the inner part of the motherboard as it shows on the following picture.



2. Insert the wireless LAN card vertically and firmly into the slot so the wireless card is properly seated.

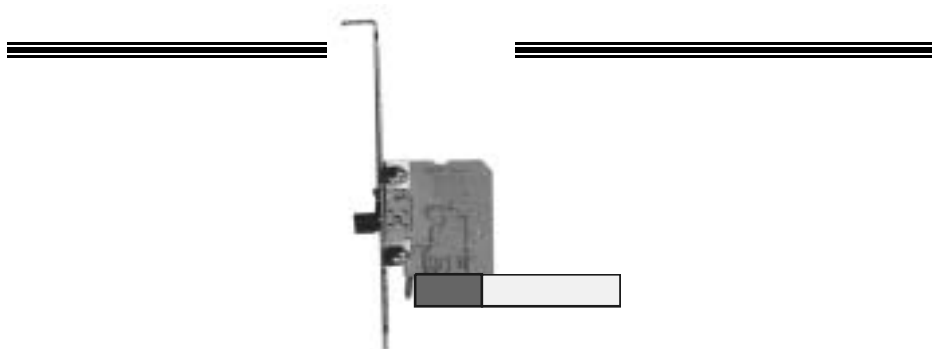

-
-
3. Screw the brackets.
 4. Insert the wireless LAN antenna by turning it clockwise.

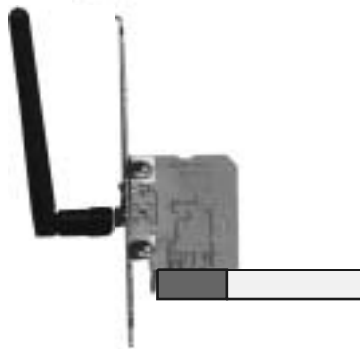

Installing DDR Module

1. Unlock a DIMM slot by pressing the retaining clips outward. Align a DIMM on the slot such that the notch on the DIMM matches the break on the slot.
2. Insert the DIMM vertically and firmly into the slot until the retaining chip snap back in place and the DIMM is properly seated



Jumpers, Headers, Connectors & Slots

Floppy Disk Connector: FDD1

The motherboard provides a standard floppy disk connector that supports 360K, 720K, 1.2M, 1.44M and 2.88M floppy disk types. This connector supports the provided floppy drive ribbon cables.

Hard Disk Connectors: IDE1/ IDE2

The motherboard has a 32-bit Enhanced PCI IDE Controller that provides PIO Mode 0-5, Bus Master, and Ultra DMA 33/ 66/ 100 functionality. It has two HDD connectors IDE1 (primary) and IDE2 (secondary).

The IDE connectors can connect a master and a slave drive, so you can connect up to four hard disk drives. The first hard drive should always be connected to IDE1.

Peripheral Component Interconnect Slots: PCI-5

This motherboard is equipped with 5 standard PCI slots. PCI stands for Peripheral Component Interconnect, and it is a bus standard for expansion cards. This PCI slot is designated as 32 bits.

Accelerated Graphics Port Slot: AGP1

Your monitor will attach directly to that video card. This motherboard supports video cards for PCI slots, but it is also equipped with an Accelerated Graphics Port (AGP). An AGP card will take advantage of AGP technology for improved video efficiency and performance, especially with 3D graphics.

Communication Network Riser Slot: CNR1

The CNR specification is an open Industry Standard Architecture, and it defines a hardware scalable riser card interface, which supports modem only.

Serial ATA Connector: JSATA1/ JSATA2

The motherboard has a PCI to SATA Controller with 2 channels SATA interface, it satisfies the SATA 1.0 spec and can transfer data with 1.5 Gbits/s speed.

Front Panel Connector: JPANEL1

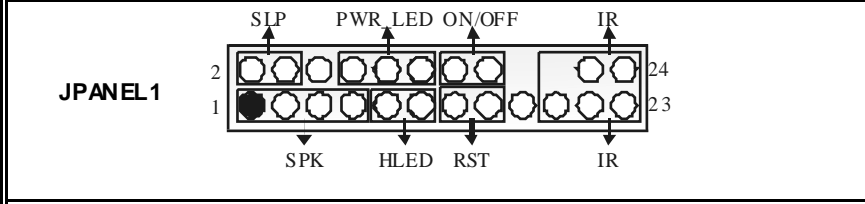

Pin	Assignment	Function	Pin	Assignment	Function
1	+5V	Speaker Connector	2	Sleep Control	Sleep Button
3	NA		4	Ground	
5	NA		6	NA	NA
7	Speaker		8	Power LED (+)	POWER LED
9	HDD LED (+)	10	Power LED (+)		
11	HDD LED (-)	12	Power LED (-)		
13	Ground	Reset Button	14	Power Button	Power-on Button
15	Reset Control		16	Ground	
17	NA		18	KEY	
19	NA	IrDA Connector	20	KEY	IrDA Connector
21	+5V		22	Ground	
23	IRTX		24	IRRX	

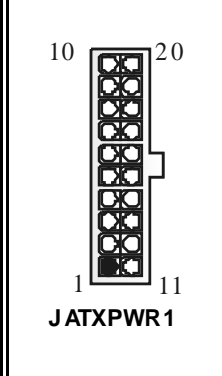

Power Connectors: JATXPWR1/ JATXPWR2



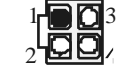

PIN	Assignment	PIN	Assignment
1	+3.3V	11	+3.3V
2	+3.3V	12	-12V
3	Ground	13	Ground
4	+5V	14	PS_ON
5	Ground	15	Ground
6	+5V	16	Ground
7	Ground	17	Ground
8	PW_OK	18	-5V
9	+5V_SB	19	+5V
10	+12V	20	+5V

 <p>JATXPWR2</p>	PIN	Assignment	PIN	Assignment
	1	+12V	3	Ground
	2	+12V	4	Ground



5V / 5VSB Selection for KB: JKBV1

JKBV1	Assignment	Description
 <p>Pin 1-2 close</p>	+5V	5V for key board and mouse
 <p>Pin 2-3 close</p>	+5V_SB	5V standby for keyboard and mouse to power on your system

5V / 5VSB Selection for USB: JUSBV1/ JUSBV2/JUSBV3_4

JUSBV1/JUSBV2/ JUSBV3_4	Assignment	Description
 <p>Pin 1-2 close</p>	+5V	5V JUSBV1 for JUSB1 port 5V JUSBV2 for JRJ45USB1 port 5V JUSBV3_4 for JUSB2/3 ports
 <p>Pin 2-3 close</p>	+5V_SB	JUSBV1 5V standby to power on JUSB1 port JUSBV2 5V standby to power on JRJ45USB1 port JUSBV3_4 5V standby to power on JUSB2/3 ports

Clear CMOS Jumper: JCMOS1

JCMOS1		Assignment
1	 3 Pin 1-2 Close	Normal Operation (default)
1	 3 Pin 2-3 Close	Clear CMOS Data

※ Clear CMOS Procedures:

1. Remove AC power line.
2. Set the jumper to "Pin 1-2 Close".
3. Wait for five seconds.
4. Set the jumper to "Pin 2-3 Close".
5. Power on the AC.
6. Reset your desired password or clear the CMOS data.

Case Open Connector: JCL1

JCL1		Pin	Assignment
1		1	Case Open Signal
		2	Ground

Serial ATA Connector: JSATA1/ JSATA2

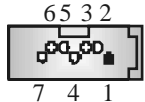
JSATA1/ JSATA2		Pin	Assignment	Pin	Assignment
		1	Ground	2	TX+
		3	TX-	4	Ground
		5	RX-	6	RX+
		7	Ground		

AUDIO DJ Connector: JDJ1

JDJ1		Pin	Assignment	Pin	Assignment
5		1	SMBDATA	2	SMBCLK
		3	INT_B	4	KEY
		5	ATX_PWROK		

Game Header: JGAME1

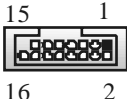
 <p style="text-align: center;">JGAME1</p>			
Pin	Assignment	Pin	Assignment
1	+5V	2	+5V
3	GPSB1	4	GPSB1
5	R_GPX2	6	R_GPX1
7	MDI-OUT	8	Ground
9	R_GPY2	10	Ground
11	GPSB2	12	R_GPY 1
13	MIDI-IN	14	GPSA2
15	NA	16	+5V

CD-ROM Audio-In Header: JCDIN1

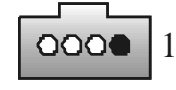
 <p style="text-align: center;">JCDIN1</p>	Pin	Assignment
	1	Left Channel Input
	2	Ground
	3	Ground
	4	Right Channel Input

Front Panel Audio Header: JAUDIO1

 <p style="text-align: center;">JAUDIO1</p>			
Pin	Assignment	Pin	Assignment
1	Mic In	2	Ground
3	Mc Power	4	Audio Power
5	RT Line Out	6	RT Line Out
7	Reserved	8	Key
9	LFT Line Out	10	LFT Line Out
11	RT Line In	12	RT Line In
13	LET Line In	14	LET Line In

Digital Audio Connector: JSPDIF_OUT1

 JSPDIF_OUT1	Pin	Assignment
	1	+5V
	2	SPDIF_OUT
	3	Ground

Wake On LAN Header: JWOL1

 JWOL1	Pin	Assignment
	1	+5V_SB
	2	Ground
	3	Wake up

Front USB Header: JUSB2/3

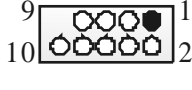
 JUSB2/3	Pin	Assignment	Pin	Assignment
	1	+5V(fused)	2	+5V(fused)
	3	USBP	4	USBP
	5	USBP	6	USBP
	7	Ground	8	Ground
	9	KEY	10	NC

Front 1394 Header: J1394A1/ J1394B1

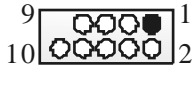
 J1394A1/ B1	Pin	Assignment	Pin	Assignment
	1	A+	2	A-
	3	Ground	4	Ground
	5	B+	6	B-
	7	+12V	8	+12V
	9	KEY	10	Ground

Back Panel Connectors

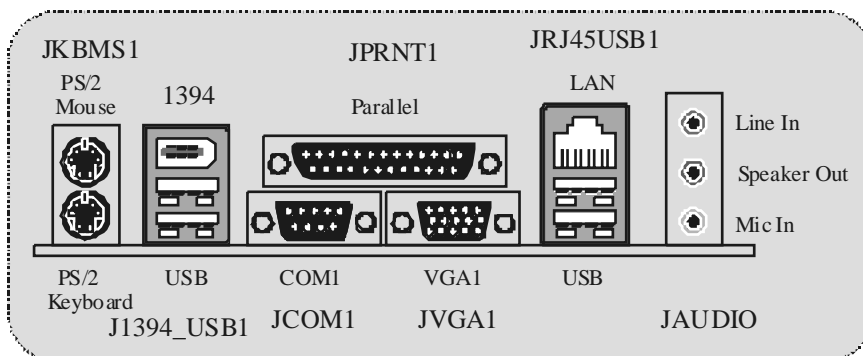

StudioFun!

Introduction

StudioFun! is a media-player based on optimized GNU/Linux distribution. It plays DVD, VCD, MP3, Audio CD and various other known file formats. You can take snapshots of video and customize the saved images as screensavers. You can also store the images on USB mass storage devices like flash disks and USB floppy disks.

Hardware Requirements

The supported hardware list of StudioFun! grows up every day. So please check the hwreq.txt located in the root of StudioFun! Installation CD to get the most updated information.

Installation Procedure

Insert the StudioFun! Installation CD in a CD/DVD ROM drive and let the system boot through the CD. The disk will boot and bring up the grub boot loader installation menu. Two options are specified.

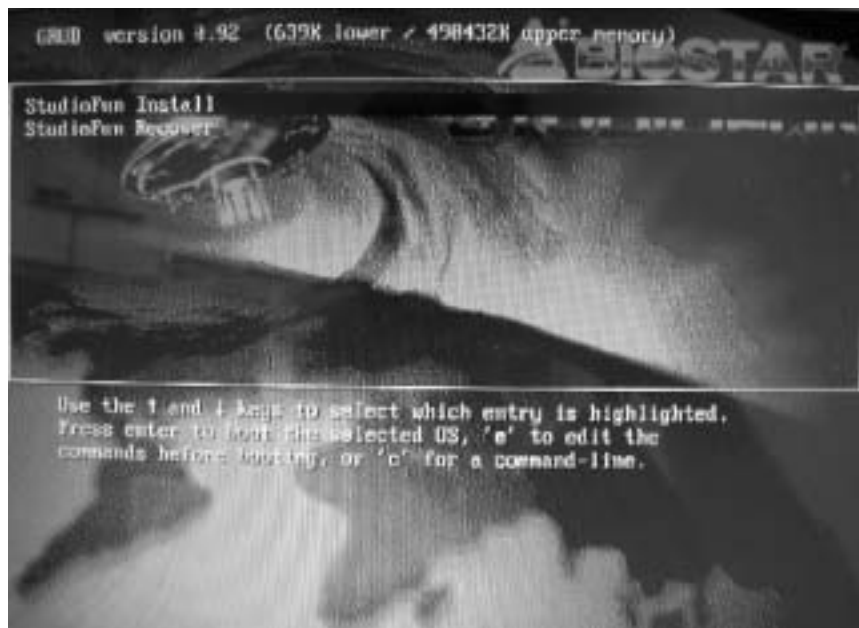

Installation

This option will do the basic installation of the distribution. The installation works on pre-installed windows or GNU/Linux distribution.

On selecting the 'installation' option the installer boots and displays a dialog box indicating the space required and waits for a confirmation. Selecting Ok will continue the installation while selecting Cancel will terminate the installation and reboot the machine.

If Windows or GNU/Linux is the only OS installed on the hard disk with no free space, it will resize the partition, either NTFS or FAT32 or ext2, and install StudioFun!. In case the hard disk has a 128MB of free space available, the installation will use the free space.

After installing the base system you will be prompted to select the resolution from the following choices

1. 1024x768 (recommended)
2. 800x600
3. 640x480

Select the desired resolution. The default is 1024x768 or high-end graphics.

Next you will be prompted to choose the DVD area/region selection code. Choose this based on the type of DVD you will be playing.

The installation procedure will then probe for the type of mouse installed. The distribution currently supports PS/2, USB and Serial mice. In case of serial mouse you will have to move the mouse when prompted. The other two are probed and installed automatically.

The installation procedure will now finish, the CD is ejected and a dialog box prompting to reboot the machine is displayed. Press OK button and enjoy StudioFun!.

3.1.1 Error Messages

1. Media corrupted!! Please check the media! The CD-ROM is corrupted
2. Extraction of base system failed!! Please try again later!! The CD-ROM is corrupted.
3. Unsupported hardware found, Aborting.. If you try to install StudioFun! on an unsupported and undocumented hardware the above error message is popped.
4. No device found! This error message is given if there is no hard disk in the system.

Recovery

In case of a MBR corruption, this option should be used. It will automatically probe the hard disk master boot record and find out the installed operating system(s). On success it will re-install the boot loader with correct options in the MBR. Any custom boot loader option specified from other GNU/Linux installations will get over written by the newly probed one.

Booting to StudioFun!

After Installation is over, remove the CD from the CD-ROM and restart the machine. After the machine reboots, you will get the GRUB boot loader menu screen. Select the StudioFun! option to boot to the StudioFun! partition.

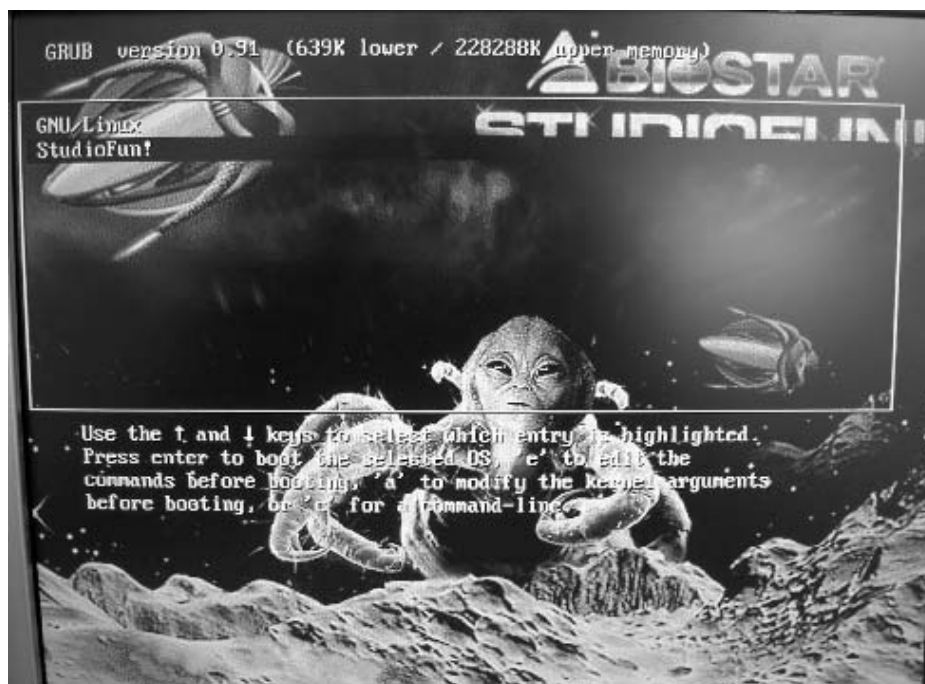

After complete boot up, you get to the main Desktop screen. The following section is a complete description of the Desktop application.

Desktop



This is the main shell of the StudioFun software. It basically comprises of two categories, one is the main "media control" part and the other is the "control panel".

Media control

The media control part of the Desktop has the following controls:

1. VCD

This control will glow whenever a VCD is detected in a DVD/CD-ROM drive. The VCD will be auto-played only when it is put in to the drive when the Desktop (StudioFun! shell) is up and running, otherwise, the control will simply glow to inform the user about a VCD

present in the DVD/CD-ROM drive.

2. DVD

This control will glow whenever a DVD is detected in a DVD drive. The DVD will be auto-played only when it is put in to the drive when the Desktop (StudioFun! shell) is up and running, otherwise, the control will simply glow to inform the user about a DVD present in the DVD/CD-ROM.

3. MP3

This control will glow whenever a MP3 is detected in a DVD/CD-ROM drive. The MP3 will be auto-played only when it is put in to the drive when the Desktop (StudioFun! shell) is up and running, otherwise, the control will simply glow to inform the user about a MP3 present in the DVD/CD-ROM drive.

4. AUDIO

This control will glow whenever a AUDIO is detected in a DVD/CD-ROM drive. The AUDIO will be auto-played only when it is put in to the drive when the Desktop (StudioFun! shell) is up and running, otherwise, the control will simply glow to inform the user about a AUDIO present in the DVD/CD-ROM drive.

5. FILE

This control will glow whenever a File CD (CDs with other media type files) is detected in a DVD/CD-ROM drive. The File CD will be auto-played only when it is put in to the drive when the Desktop (StudioFun! shell) is up and running, otherwise, the control will simply glow to inform the user about a File CD present in the DVD/CD-ROM drive.

6. EJECT MEDIA

This control when clicked will eject any MP3 or File CDs from any of the DVD/CDROM drives. In case there were no MP3 or File CDs it will eject the default medium, (i.e.), the CD-ROM drive in case if the user has both DVD/CD-ROM drive or else it will eject the default DVD/CD-ROM drive.

7. EXIT

This is the "Power on/off" control of the Desktop (StudioFun! shell).

Control Panel

Control panel part has five icons, which are shortcuts to other applications present in the StudioFun software. Tool tips are provided on the icons when the mouse is rolled over them.

1. Select Region

Clicking this icon will invoke the application for selection DVD region settings. Refer to section 5.2 Select DVD Region application for more details.

2. Screensaver

Clicking this icon will invoke the screensaver application. Refer to section 5.3 **Screensaver** for more details.

3. Display Settings

Clicking this icon will invoke the application for changing the screen resolutions. Refer to section 5.4, **Display Settings** for more details.

4. File Manager

Clicking this icon will invoke the file manager. Refer to section 5.6 **File manager** for more details.

When user has a DVD and a CD-ROM Drive:

If user has both DVD and a CD-ROM drive, DVD drive will be given the preference when both the drives hold valid media in them, i.e., if the CD-ROM drive has a media and a DVD drive also has a media, and the StudioFun! is started, then the media inside the DVD drive will be played.

If in case the media in CD-ROM takes a longer time to get recognized than the media inside the DVD drive, the media in the CD-ROM will be played, once it is recognized.

Other general user scenarios

When a user clicks on any of the media-controls when it is not glowing, except eject media and exit, the media-player will just come up and wait for user input.

NO DUPLICATE INSTANCE OF ANY APPLICATION WILL BE ALLOWED TO RUN.

-
-
- f. MPEG-Video (.mpv, .m2v)
 - g. MPEG-Audio (.mp2, .mp3)
 - h. WAV(.wav) Video Codecs
 - i. MPEG 1/2
 - j. MPEG 4 (aka OpenDivX)
 - k. MSMPEG 4
 - a. Chapter 5: Software Details 10
 - l. Windows Media Video 7
 - m. Motion JPEG

• **Remote Control support.**

- a. Infrared interface
- b. User-friendly

• **Usage of StudioFun! with CelomaChrome skin**

- a. Select VCD button to play a VCD disc
 - b. Select DVD button to play a DVD disc
 - c. Select CDDA button to play a Audio cd
 - d. Select next chapter or MRL (>>|) button to play next track in Audio CD, VCD and MP3 songs and to play next chapter in DVD
 - e. Select previous chapter or MRL (|<<) button to play previous track in Audio CD, VCD and MP3 songs and to play previous chapter in DVD
 - f. Select slow motion (<<) button to play the video / audio in slow motion (Select play button after reaching the required position)
 - g. Select fast motion (>>) button to play the video / audio in fast motion (Select play button after reaching the required position)
 - h. Select subs +/- button to select the appropriate subtitle (Usable while playing)
 - i. Select audio +/- button to select the appropriate audio track (For example when
 - j. The DVD contains one audio track in English and the other with some other language,
 - k. Usable while playing DVD's)
-
-

-
-
- l. j. Select hide button to hide the control panel of the player
 - m. k. Select menu button to use menu's while playing DVD
 - n. l. Select control button to adjust brightness / color
 - o. Select setup button to modify the settings of the player
 - p. Select f.scr button to show the video output of the player in full screen mode
 - q. Select snap button to take a snapshot of the currently playing video
 - r. Select plist button to add / remove / manage play list
 - s. Select mrl button to add new file to play

Error Messages

- ✧ The following error message is given if an unknown file format is selected through Xine MRL browser and played.
- ✧ While playing mp3 files, if the user stops playing and tries to select the DVD button, then the following error message is shown

Select Region

Overview

Select region is a utility to set a DVD region. With the help of this application user can set or change a DVD region. Only one region can be set at a time.

About Select Region

With the help of this application you can set a region for DVD. Only one region can be set at a time. If you keep the mouse pointer on any region, you can view the countries, which comes under that region.

Ok - Click to set the selected region.

Cancel - Click to quit the application.

How to select DVD region

You can select only one region at a time. You can change your selection by clicking on any other region.

- A snapshot of the application is shown below:

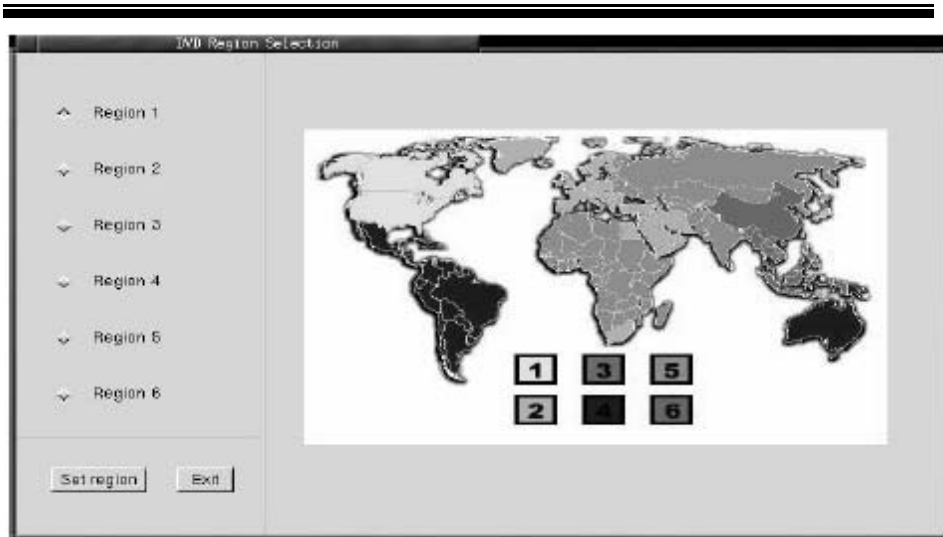

Screensaver

Screensaver

The xscreensaver daemon waits until the keyboard and mouse have been idle for a period, and then runs a graphics demo chosen at random. The demo is terminated as soon as there is any mouse or keyboard activity.

The xscreensaver-demo program is the graphical user interface to xscreensaver. It lets you tune the various parameters used by the xscreensaver daemon, and browse through the graphics demos.

StudioFun! comes with xscreensaver when you click on the screensaver icon the application comes up. Then user can choose various graphics demos like chbg, hab, hypercube or hyperball.

Screensaver comes with various options

- **Preview Option:** When a user selects a particular graphics demo and clicks on preview button the demo comes up
- **Blank After Option:** The screensaver will blank the screen after the keyboard and mouse have been idle default time is 1 minute and user can change the settings.
- **Cycle After Option:** When screensaver is running this cycle time defines the time limit for each screensaver.
- **Mode Screensaver comes with various modes:**
 1. **Random Screen Saver:** When user chooses this option, Screensaver cycles through various graphics demos randomly

-
2. Only one Screen Saver: When user chooses this option, screensaver displays only one graphics demo.
 3. Blank Screen Only: When user chooses this option, screensaver only blanks the screen instead of displaying the graphics demo.
 4. Disable Screen Saver: When user chooses this option, screensaver is disabled.

- Various Graphics Demos

XScreensaver comes with various screensaver

Chbg: This screensaver displays the images stored in StudioFun! the time gap between images is 5 seconds.

Hyperball

Hypercube

Halo

Strange

- A snapshot of the application is shown below:

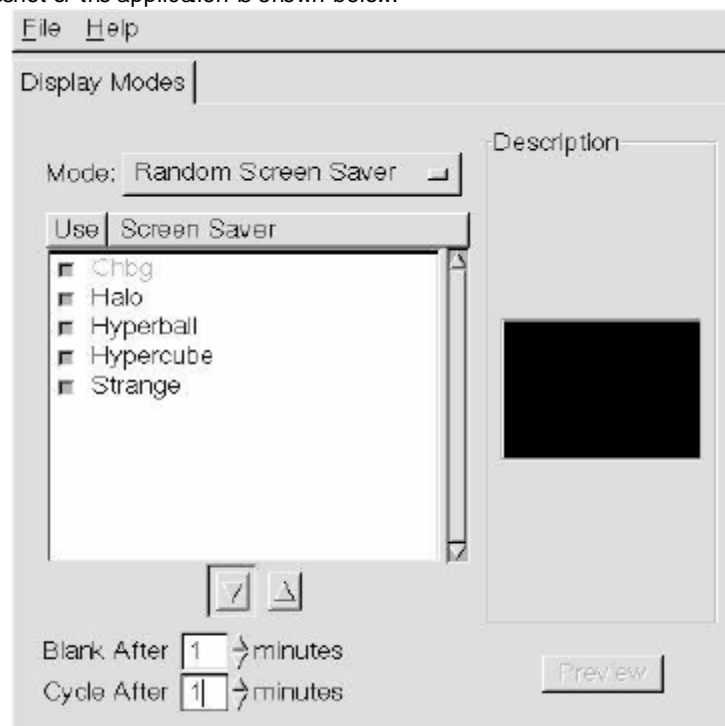

Display Settings

Display Settings

Display setting is a program to change the current resolution settings of the Display.

By default user of StudioFun will be given a choice to select between any of the following

three resolutions.

- 640x480
- 800x600
- 1024x768

The current resolution of the Display will be selected by default. It requires restart of the StudioFun to reflect the changes made.

File Manager

Overview

File manger is an utility to copy files from deferent devices to hard disk and vice versa. User can copy files from dev ices such as, floppy, cdrom and flashdisk to hard disk. And also from hard disk to floppy and flashdisk.

About File manager

The hard disk files are stored in a directory called "/studiofun" on the hard disk. You can also delete files from hard disk, but you cannot delete files from any device.

- ✧ Select device - Contains the device names /floppy, /cdrom and /flashdisk. Select a device from/to which you want to copy files. **Please double click the device option twice to mount the device.**
- ✧ List Directories - Shows the list of directories of the selected device after double clicking it.
- ✧ Floppy/cdrom/Flashdisk - Shows the contents of the selected directory from the "List directories" field after double clicking it.
- ✧ Hard disk - Shows the contents of a directory called "/studiofun".
- ✧ Add (>>) - Click to copy selected files from a device to hard disk.
- ✧ Add (<<) - Click to copy selected files from hard disk to a device.
- ✧ Remove - Click to delete files from hard disk.
- ✧ Exit - Click to quit the application.

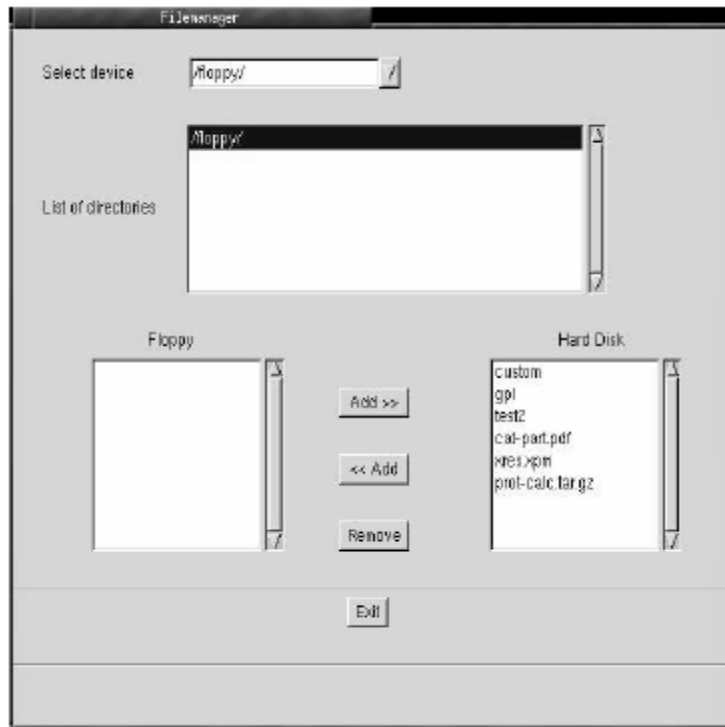

WarpSpeeder



Introduction

[WarpSpeeder™], a new powerful control utility, features three user-friendly functions including Overclock Manager, Overvoltage Manager, and Hardware Monitor.

With the Overclock Manager, users can easily adjust the frequency they prefer or they can get the best CPU performance with just one click. The Overvoltage Manager, on the other hand, helps to power up CPU core voltage and Memory voltage. The cool Hardware Monitor smartly indicates the temperatures, voltage and CPU fan speed as well as the chipset information. Also, in the About panel, you can get detail descriptions about BIOS model and chipsets. In addition, the frequency status of CPU, memory, AGP and PCI along with the CPU speed are synchronically shown on our main panel.

Moreover, to protect users' computer systems if the setting is not appropriate when testing and results in system fail or hang, [WarpSpeeder™] technology assures the system stability by automatically rebooting the computer and then restart to a speed that is either the original system speed or a suitable one.

System Requirement

OS Support: Windows 98 SE, Windows Me, Windows 2000, Windows XP

DirectX: DirectX 8.1 or above. (The Windows XP operating system includes DirectX 8.1. If you use Windows XP, you do not need to install DirectX 8.1.)

Installation

1. Execute the setup execution file, and then the following dialog will pop up. Please click “Next” button and follow the default procedure to install.



2. When you see the following dialog in setup procedure, it means setup is completed. If the “Launch the WarpSpeeder Tray Utility” checkbox is checked, the Tray Icon utility and [WarpSpeeder™] utility will be automatically and immediately launched after you click “Finish” button.

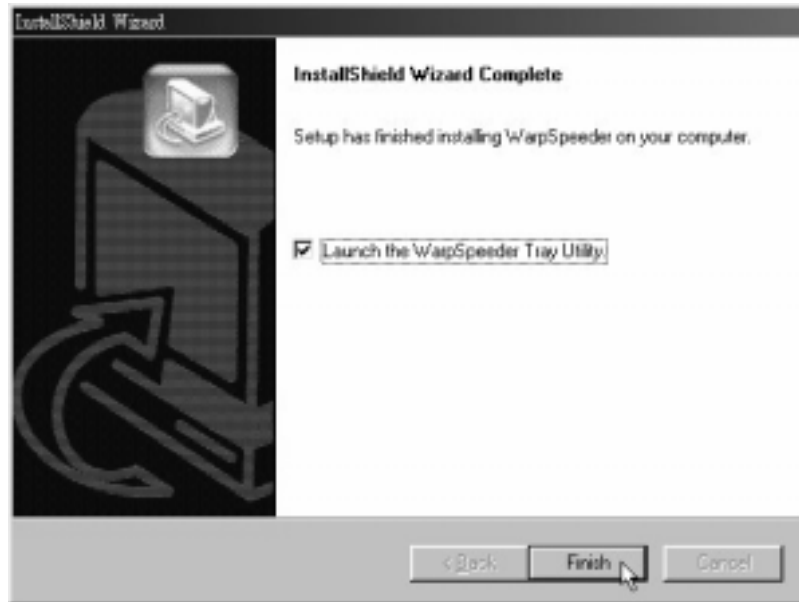

Usage

The following figures are just only for reference, the screen printed in this user manual will change according to your motherboard on hand.

[WarpSpeeder™] includes 1 tray icon and 5 panels:

1. Tray Icon:

Whenever the Tray Icon utility is launched, it will display a little tray icon on the right side of Windows Taskbar.

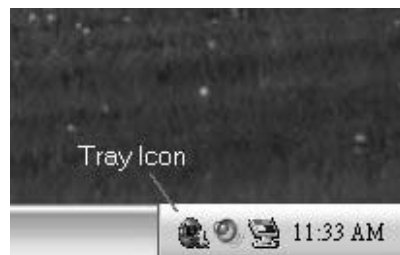

This utility is responsible for conveniently invoking [WarpSpeeder™] Utility. You can use the mouse by clicking the left button in order to invoke [WarpSpeeder™] directly from the little tray icon or you can right-click the little tray icon to pop up a popup menu as following figure. The “Launch Utility” item in the popup menu has the same function as mouse left-click on tray icon and “Exit” item will close Tray Icon utility if selected.



2. Main Panel

If you click the tray icon, [WarpSpeeder™] utility will be invoked. Please refer to the following figure; the utility's first window you will see is Main Panel.

Main Panel contains features as follows:

- a. Display the CPU Speed, CPU external clock, Memory clock, AGP clock, and PCI clock information.
- b. Contains About, Voltage, Overclock, and Hardware Monitor Buttons for invoking respective panels.
- c. With a user-friendly Status Animation, it can represent 3 overclock percentage stages:

Duck walking => overclock percentage from 100% ~ 110%

Duck running => overclock percentage from 110% ~ 120%

Duck burning => overclock percentage from 120% ~ above

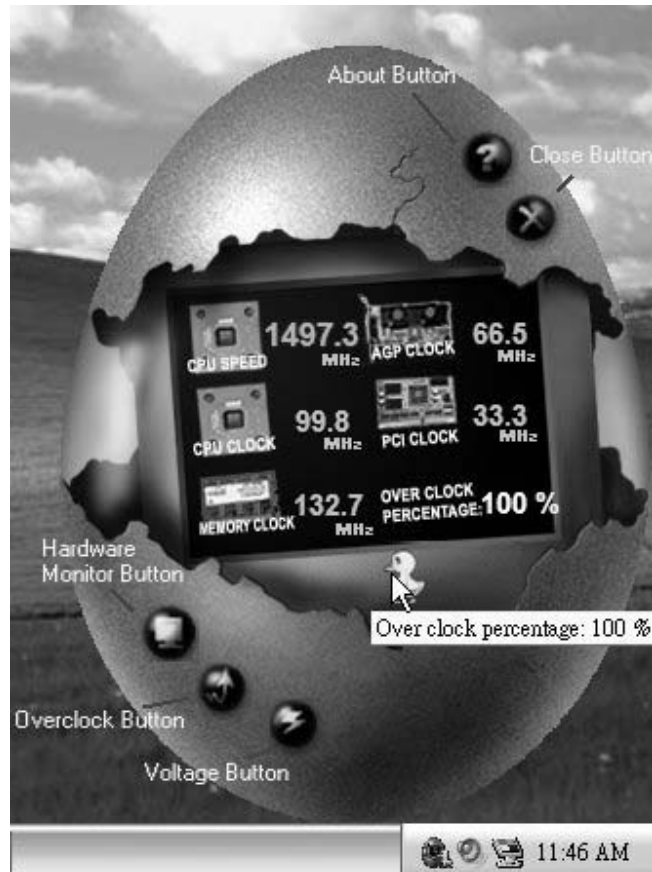

3. Voltage Panel

Click the Voltage button in Main Panel, the button will be highlighted and the Voltage Panel will slide out to up as the following figure.

In this panel, you can decide to increase CPU core voltage and Memory voltage or not. The default setting is "No". If you want to get the best performance of overclocking, we recommend you click the option "Yes".

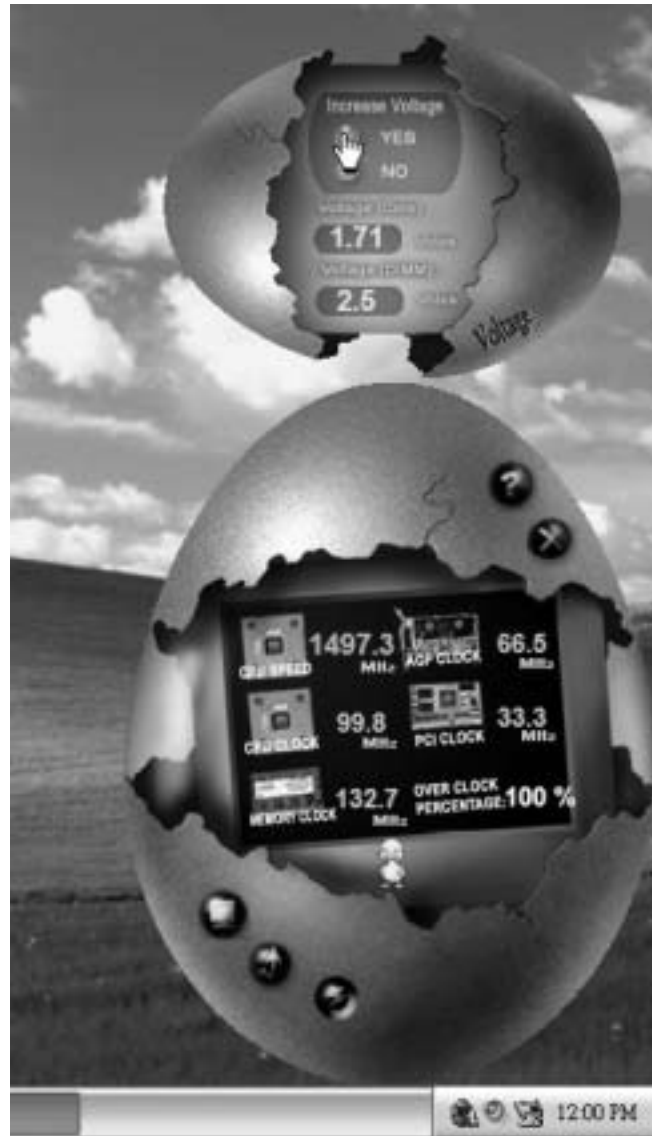

4. Overclock Panel

Click the Overclock button in Main Panel, the button will be highlighted and the Overclock Panel will slide out to left as the following figure.



Overclock Panel contains these features:

- a. “-3MHz button”, “-1MHz button”, “+1MHz button”, and “+3MHz button”: provide user the ability to do real-time overclock adjustment.

Warning: Manually overlock is potentially dangerous, especially when the overlocking percentage is over 110 %. We strongly recommend you verify every speed you overclock by click the Verify button. Or, you can just click Auto overclock button and let [WarpSpeeder™] automatically gets the best result for you.

- b. “Recovery Dialog button”: Pop up the following dialog. Let user select a restoring way if system need to do a fail-safe reboot.

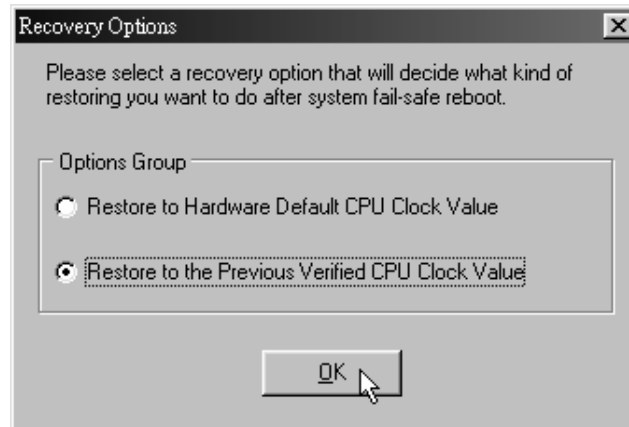

- d. "Auto-overclock button": User can click this button and [WarpSpeeder™] will set the best and stable performance and frequency automatically. [WarpSpeeder™] utility will execute a series of testing until system fail. Then system will do fail-safe reboot by using Watchdog function. After reboot, the [WarpSpeeder™] utility will restore to the hardware default setting or load the verified best and stable frequency according to the Recovery Dialog's setting.
- e. "Verify button": User can click this button and [WarpSpeeder™] will proceed a testing for current frequency. If the testing is ok, then the current frequency will be saved into system registry. If the testing fail, system will do a fail-safe rebooting. After reboot, the [WarpSpeeder™] utility will restore to the hardware default setting or load the verified best and stable frequency according to the Recovery Dialog's setting.

Note: Because the testing programs, invoked in Auto-overclock and Verify, include DirectDraw, Direct3D and DirectShow tests, the DirectX 8.1 or newer runtime library is required. And please make sure your display card's color depth is High color (16 bit) or True color (24/32 bit) that is required for Direct3D rendering.

5. Hardware Monitor Panel

Click the Hardware Monitor button in Main Panel, the button will be highlighted and the Hardware Monitor panel will slide out to left as the following figure.

In this panel, you can get the real-time status information of your system. The information will be refreshed every 1 second.



6. About Panel

Click the About button in Main Panel, the button will be highlighted and the About Panel will slide out to up as the following figure.

In this panel, you can get model name and detail information in hints of all the chipset that are related to overclocking. You can also get the mainboard's BIOS model and the Version number of [WarpSpeeder™] utility.

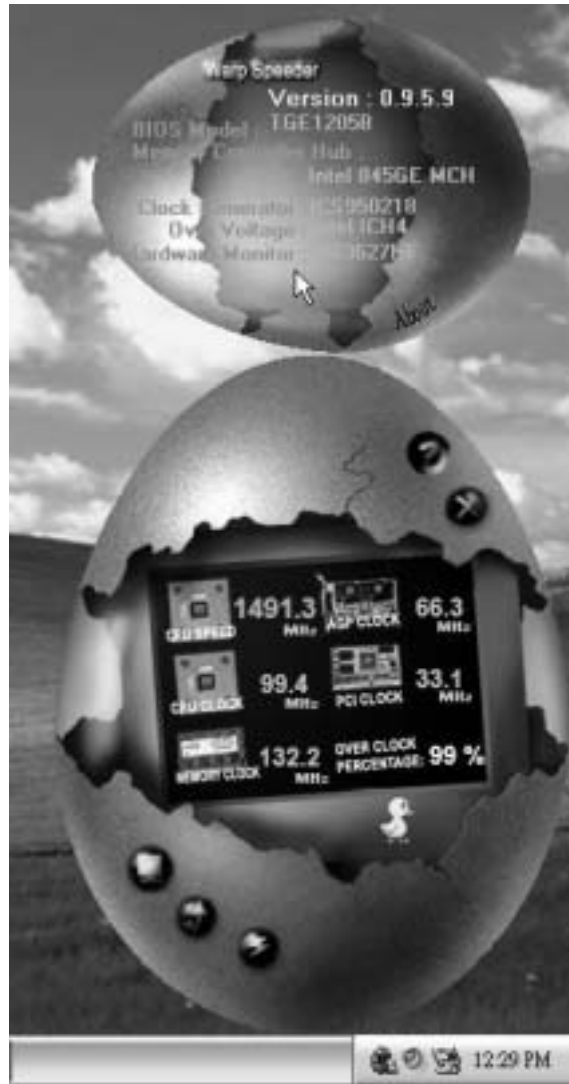

Note: Because the overclock, overvoltage, and hardware monitor features are controlled by several separate chipset, [WarpSpeeder™] divide these features to separate panels. If one chipset is not on board, the correlative button in Main panel will be disabled, but will not interfere other panels functions. This property can make [WarpSpeeder™] utility more robust.

Trouble Shooting

PROBABLE	SOLUTION
No power to the system at all. Power light don't illuminate, fan inside power supply does not turn on. Indicator light on keyboard does not turn on.	<ul style="list-style-type: none"> * Make sure power cable is securely plugged in. * Replace cable * Contact technical support
System inoperative. Keyboard lights are on, power indicator lights are lit, hard drive is spinning.	<ul style="list-style-type: none"> * Using even pressure on both ends of the DIMM, press down firmly until the module snaps into place.
System does not boot from hard disk drive, can be booted from CD-ROM drive.	<ul style="list-style-type: none"> * Check cable running from disk to disk controller board. Make sure both ends are securely plugged in; check the drive type in the standard CMOS setup. * Backing up the hard drive is extremely important. All hard disks are capable of breaking down at any time.
System only boots from CD-ROM. Hard disk can be read and applications can be used but booting from hard disk is impossible.	<ul style="list-style-type: none"> * Back up data and applications files. Reformat the hard drive. Re-install applications and data using backup disks.
Screen message says "Invalid Configuration" or "CMOS Failure."	<ul style="list-style-type: none"> * Review system's equipment. Make sure correct information is in setup.
Cannot boot system after installing second hard drive.	<ul style="list-style-type: none"> * Set master/slave jumpers correctly. * Run SETUP program and select correct drive types. Call drive manufacturers for compatibility with other drives.

05/5/2003

P4TSG Pro BIOS Setup

BIOS Setup.....	1
1 Main Menu.....	3
2 Standard CMOS Features	6
3 Advanced BIOS Features.....	9
4 Advanced Chipset Features.....	13
5 Integrated Peripherals	16
6 Power Management Setup	20
7 PnP/PCI Configurations	24
8 PC Health Status	26
9 Frequency Control	28

P4TSG Pro BIOS Setup

BIOS Setup

Introduction

This manual discussed Award™ Setup program built into the ROM BIOS. The Setup program allows users to modify the basic system configuration. This special information is then stored in battery-backed RAM so that it retains the Setup information when the power is turned off.

The Award BIOS™ installed in your computer system's ROM (Read Only Memory) is a custom version of an industry standard BIOS. This means that it supports Intel Pentium® 4 processor input/output system. The BIOS provides critical low-level support for standard devices such as disk drives and serial and parallel ports.

Adding important has customized the Award BIOS™, but nonstandard, features such as virus and password protection as well as special support for detailed fine-tuning of the chipset controlling the entire system.

The rest of this manual is intended to guide you through the process of configuring your system using Setup.

Plug and Play Support

These AWARD BIOS supports the Plug and Play Version 1.0A specification. ESCD (Extended System Configuration Data) write is supported.

EPA Green PC Support

This AWARD BIOS supports Version 1.03 of the EPA Green PC specification.

APM Support

These AWARD BIOS supports Version 1.1&1.2 of the Advanced Power Management (APM) specification. Power management features are implemented via the System Management Interrupt (SMI). Sleep and Suspend power management modes are supported. This AWARD BIOS can manage power to the hard disk drives and video monitors .

ACPI Support

Award ACPI BIOS support Version 1.0 of Advanced Configuration and Power interface specification (ACPI). It provides ASL code for power management and device configuration capabilities as defined in the ACPI specification, developed by Microsoft, Intel and Toshiba.

P4TSG Pro BIOS Setup

PCI Bus Support

This AWARD BIOS also supports Version 2.1 of the Intel PCI (Peripheral Component Interconnect) local bus specification.

DRAM Support

DDR DRAM (Double Data Rate Synchronous DRAM) are supported.

Supported CPUs

This AWARD BIOS supports the Intel Pentium[®] 4 CPU.

Using Setup

In general, you use the arrow keys to highlight items, press <Enter> to select, use the <PgUp> and <PgDn> keys to change entries, press <F1> for help and press <Esc> to quit. The following table provides more detail about how to navigate in the Setup program by using the keyboard.

Keystroke	Function
Up arrow	Move to previous item
Down arrow	Move to next item
Left arrow	Move to the item on the left (menu bar)
Right arrow	Move to the item on the right (menu bar)
Move Enter	Move to the item you desired
PgUp key	Increase the numeric value or make changes
PgDn key	Decrease the numeric value or make changes
+ Key	Increase the numeric value or make changes
- Key	Decrease the numeric value or make changes
Esc key	Main Menu – Quit and not save changes into CMOS Status Page Setup Menu and Option Page Setup Menu – Exit Current page and return to Main Menu
F1 key	General help on Setup navigation keys
F5 key	Load previous values from CMOS
F7 key	Load the optimized defaults
F10 key	Save all the CMOS changes and exit

P4TSG Pro BIOS Setup

1 Main Menu

Once you enter Award BIOS™ CMOS Setup Utility, the Main Menu will appear on the screen. The Main Menu allows you to select from several setup functions. Use the arrow keys to select among the items and press <Enter> to accept and enter the sub-menu.

WARNING

The information about BIOS defaults on manual (**Figure 1,2,3,4,5,6,7,8,9**) is just for reference, please refer to the BIOS installed on board, for update information.

■ Figure 1. Main Menu

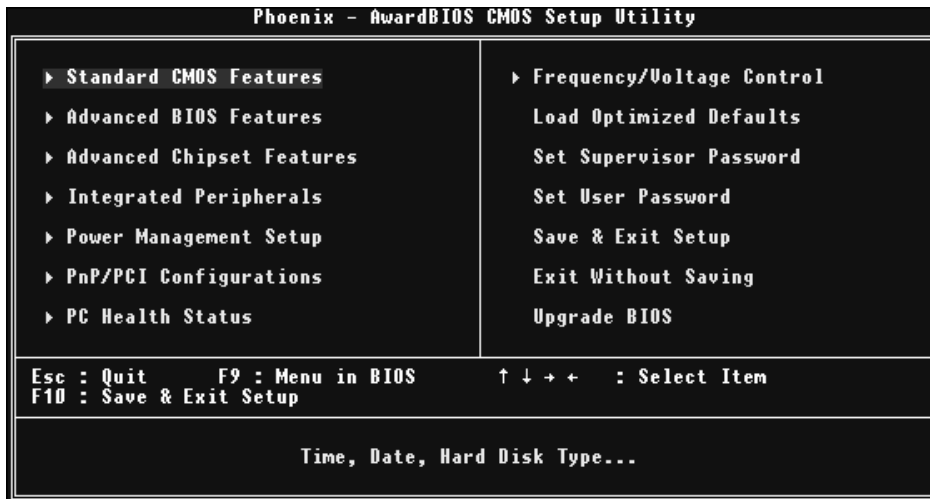

Standard CMOS Features

This submenu contains industry standard configurable options.

Advanced BIOS Features

This submenu allows you to configure enhanced features of the BIOS.

Advanced Chipset Features

This submenu allows you to configure special chipset features.

Integrated Peripherals

This submenu allows you to configure certain IDE hard drive options and Programmed

P4TSG Pro BIOS Setup

Input/ Output features.

Power Management Setup

This submenu allows you to configure the power management features.

PnP/PCI Configurations

This submenu allows you to configure certain “Plug and Play” and PCI options.

PC Health Status

This submenu allows you to monitor the hardware of your system.

Frequency Control

This submenu allows you to change CPU Vcore Voltage and CPU/PCI clock. **(However, this function is strongly recommended not to use. Not properly change the voltage and clock may cause CPU or M/B damage!)**

Load Optimized Defaults

This selection allows you to reload the BIOS when the system is having problems particularly with the boot sequence. These configurations are factory settings optimized for this system. A confirmation message will be displayed before defaults are set.



Load Optimized Defaults (Y/N)? N

Set Supervisor Password

Setting the supervisor password will prohibit everyone except the supervisor from making changes using the CMOS Setup Utility. You will be prompted with to enter a password.



Enter Password:

Set User Password

If the Supervisor Password is not set, then the User Password will function in the same way as the Supervisor Password. If the Supervisor Password is set and the User Password is set, the “User” will only be able to view configurations but will not be able to change them.



Enter Password:

Save & Exit Setup

Save all configuration changes to CMOS(memory) and exit setup. Confirmation message

P4TSG Pro BIOS Setup

will be displayed before proceeding

```
SAVE to CMOS and EXIT (Y/N)? Y
```

Exit Without Saving

Abandon all changes made during the current session and exit setup. Confirmation message will be displayed before proceeding

```
Quit Without Saving (Y/N)? N
```

Upgrade BIOS

This submenu allows you to upgrade bios.

```
BIOS UPDATE UTILITY (Y/N)? N
```

P4TSG Pro BIOS Setup

2 Standard CMOS Features

The items in Standard CMOS Setup Menu are divided into 10 categories. Each category includes no, one or more than one setup items. Use the arrow keys to highlight the item and then use the <PgUp> or <PgDn> keys to select the value you want in each item.

■ **Figure 2. Standard CMOS Setup**



P4TSG Pro BIOS Setup

Main Menu Selections

This table shows the selections that you can make on the Main Menu.

Item	Options	Description
Date	mm : dd : yy	Set the system date. Note that the 'Day' automatically changes when you set the date.
Time	hh : mm : ss	Set the system internal clock.
IDE Primary Master	Options are in its sub menu.	Press <Enter> to enter the sub menu of detailed options
IDE Primary Slave	Options are in its sub menu.	Press <Enter> to enter the sub menu of detailed options.
IDE Secondary Master	Options are in its sub menu.	Press <Enter> to enter the sub menu of detailed options.
IDE Secondary Slave	Options are in its sub menu.	Press <Enter> to enter the sub menu of detailed options.
Drive A Drive B	360K, 5.25 in 1.2M, 5.25 in 720K, 3.5 in 1.44M, 3.5 in 2.88M, 3.5 in None	Select the type of floppy disk drive installed in your system.
Video	EGA/VGA CGA 40 CGA 80 MONO	Select the default video device.

P4TSG Pro BIOS Setup

Item	Options	Description
Halt On	All Errors No Errors All, but Keyboard All, but Diskette All, but Disk/ Key	Select the situation in which you want the BIOS to stop the POST process and notify you.
Base Memory	N/A	Displays the amount of conventional memory detected during boot up.
Extended Memory	N/A	Displays the amount of extended memory detected during boot up.
Total Memory	N/A	Displays the total memory available in the system.

P4TSG Pro BIOS Setup

3 Advanced BIOS Features

■ Figure 3. Advanced BIOS Setup

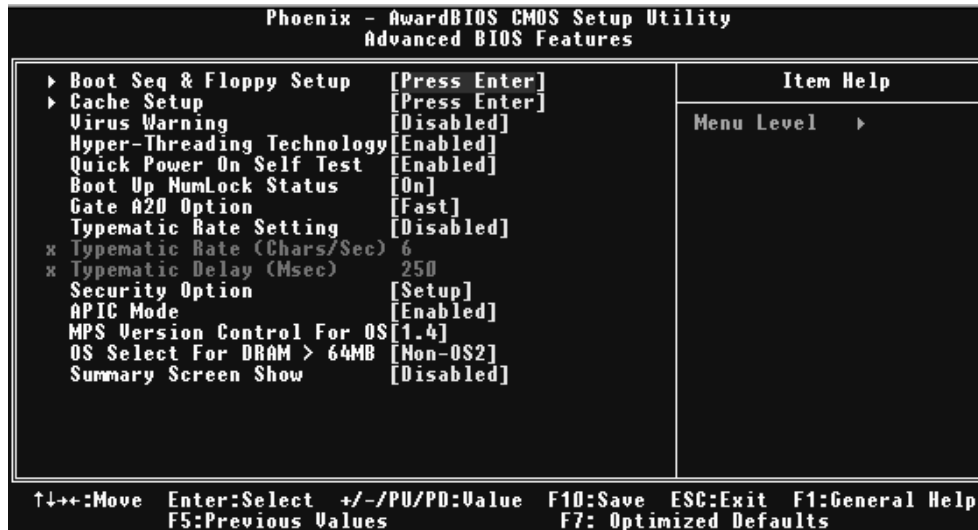

Boot Seq & Floppy Setup

First/ Second/ Third/ Boot Other Device

These BIOS attempt to load the operating system from the device in the sequence selected in these items.

The Choices: Floppy, LS120, HDD-0, SCSI, CDROM, HDD-1, HDD-2, HDD-3, ZIP 100, LAN, HPT370, Disabled, Enabled.

Swap Floppy Drive

For systems with two floppy drives, this option allows you to swap logical drive assignments.

The Choices: Disabled (default), Enabled.

Boot Up Floppy Seek

Enabling this option will test the floppy drives to determine if they have 40 or 80 tracks. Disabling this option reduces the time it takes to boot-up.

The Choices: Disabled, Enabled (default).

Report NO FDD for Win95

The Choices: NO(default).

P4TSG Pro BIOS Setup

Cache Setup

CPU L1&L2 Cache

Depending on the CPU/chipset in use, you may be able to increase memory access time with this option.

Enabled (default) Enable cache.
Disabled Disable cache.

Virus Warning

This option allows you to choose the Virus Warning feature that is used to protect the IDE Hard Disk boot sector. If this function is enabled and an attempt is made to write to the boot sector, BIOS will display a warning message on the screen and sound an alarm beep.

Enabled Virus protection is activated.
Disabled (default) Virus protection is disabled.

CPU Hyper-Threading

This option allows you to enable or disabled CPU Hyper-Threading.

The Choices: **Enabled** (Default), Disabled.

Quick Power On Self Test

Enabling this option will cause an abridged version of the Power On Self-Test (POST) to execute after you power up the computer.

Disabled Normal POST.
Enabled (default) Enable quick POST.

Boot Up NumLock Status

Selects the NumLock. State after power on.

On (default) Numpad is number keys.
Off Numpad is arrow keys.

Gate A20 Option

Select if chipset or keyboard controller should control Gate A20.

Normal A pin in the keyboard controller
 controls Gate A20.
Fast (default) Lets chipset control Gate A20.

Typematic Rate Setting

When a key is held down, the keystroke will repeat at a rate determined by the keyboard controller. When enabled, the typematic rate and typematic delay can be configured.

The Choices: **Disabled** (default), Enabled.

Typematic Rate (Chars/Sec)

Sets the rate at which a keystroke is repeated when you hold the key down.

The Choices: **6** (default), 8,10,12,15,20,24,30.

P4TSG Pro BIOS Setup

Typematic Delay (Msec)

Sets the delay time after the key is held down before it begins to repeat the keystroke.

The Choices: 250 (default), 500,750,1000.

Security Option

This option will enable only individuals with passwords to bring the system online and/or to use the CMOS Setup Utility.

System	A password is required for the system to boot and is also required to access the Setup Utility.
Setup (default)	A password is required to access the Setup Utility only.

This will only apply if passwords are set from the Setup main menu.

APIC Mode

Selecting Enabled enables ACPI device mode reporting from the BIOS to the operating system.

The Choices: Enabled (default), Disabled.

MPS Version Control For OS

The BIOS supports version 1.1 and 1.4 of the Intel multiprocessor specification.

Select version supported by the operation system running on this computer.

The Choices: 1.4 (default), 1.1.

OS Select For DRAM > 64MB

A choice other than Non-OS2 is only used for OS2 systems with memory exceeding 64MB.

The Choices: Non-OS2 (default), OS2.

Small Logo(EPA) Show

This item allows you to enable/ disable display the small EPA logo.

The Choices: Disabled (default), Enabled.

Summary Screen Show

This item allows you to enable/disable the summary screen. Summary screen means system configuration and PCI device listing.

The choices: Enabled, Disabled (default).

Boot Seq & Floppy Setup

First/ Second/ Third/ Boot Other Device

These BIOS attempt to load the operating system from the device in the sequence selected in these items.

The Choices: Floppy, LS120, HDD-0, SCSI, CDROM, HDD-1, HDD-2, HDD-3, ZIP 100, LAN, HPT370, Disabled, Enabled.

P4TSG Pro BIOS Setup

Swap Floppy Drive

For systems with two floppy drives, this option allows you to swap logical drive assignments.

The Choices: Disabled (default), Enabled.

Boot Up Floppy Seek

Enabling this option will test the floppy drives to determine if they have 40 or 80 tracks. Disabling this option reduces the time it takes to boot-up.

The Choices: Disabled, Enabled (default).

P4TSG Pro BIOS Setup

4 Advanced Chipset Features

This submenu allows you to configure the specific features of the chipset installed on your system. This chipset manage bus speeds and access to system memory resources, such as DRAM. It also coordinates communications with the PCI bus. The default settings that came with your system have been optimized and therefore should not be changed unless you are suspicious that the settings have been changed incorrectly.

■ Figure 4. Advanced Chipset Setup

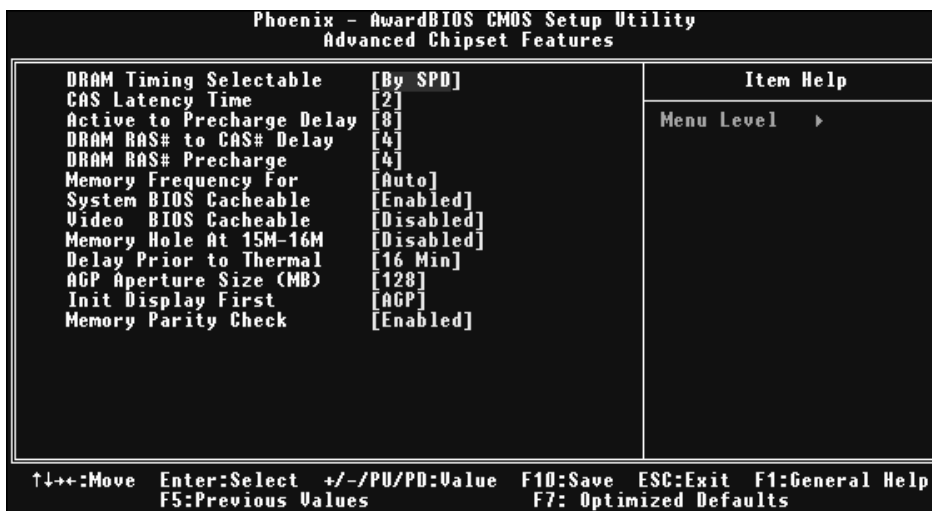

DRAM Timing Selectable

When synchronous DRAM is installed, the number of clock cycles of CAS latency depends on the DRAM timing.

The Choices: By SPD (default), Manual.

CAS Latency Time

When synchronous DRAM is installed, the number of clock cycles of CAS latency depends on the DRAM timing.

The Choices: 1.5 , 2, 2.5(default),3

Active to Precharge Delay

This item controls the number of DRAM clocks to activate the precharge delay.

The Choices: 8 (default),7, 6, 5

P4TSG Pro BIOS Setup

DRAM RAS# to CAS# Delay

This field let you insert a timing delay between the CAS and RAS strobe signals, used when DRAM is written to, read from, or refreshed. Fast gives faster performance; and slow gives more stable performance. This field applies only when synchronous DRAM is installed in the system.

The Choices: 4 (default), 3, 2.

DRAM RAS# Precharge

If an insufficient number of cycle is allowed for RAS to accumulate its charge before DRAM refresh, the refresh may be incomplete, and the DRAM may fail to retain data. Fast gives faster performance; and Slow gives more stable performance. This field applies only when synchronous DRAM is installed in the system.

The Choices: 4 (default), 3, 2.

Memory Frequency For

This item allows you to select the Memory Frequency.

The Choices: Auto (default), DDR266, DDR300, DDR400.

System BIOS Cacheable

Selecting Enabled allows you caching of the system BIOS ROM at F0000h~FFFFh, resulting a better system performance. However, if any program writes to this memory area, a system error may result.

The Choices: Enabled (default), Disabled.

Video BIOS Cacheable

Select Enabled allows caching of the video BIOS, resulting a better system performance. However, if any program writes to this memory area, a system error may result.

The Choices: Disabled, Enabled(default).

Video RAM Cacheable

This option allows you to enable or disable VGA RAM cache capability.

The Choices: Disabled (default), Enabled

Memory Hole At 15M-16M

You can reserve this area of system memory for ISA adapter ROM. When this area is reserved it cannot be cached. The user information of peripherals that need to use this area of system memory usually2 discussed their memory requirements.

The Choices: Disabled (default), Enabled.

Delay Prior to Thermal

Set this item to enable the CPU Thermal function to engage after the specified time.

The Choices: 4, 8, 16 (default), 32.

P4TSG Pro BIOS Setup

AGP Aperture Size (MB)

Select the size of the Accelerated Graphics Port (AGP) aperture. The aperture is a portion of the PCI memory address range dedicated for graphics memory address space. Host cycles that hit the aperture range are forwarded to the AGP without any translation.

The Choices: 64, 4, 8, 16, 32, **128**(default), 256.

Init Display First

This item allows you to decide to active whether PCI Slot or on-chip VGA first.

The Choices: **Onboard** (default), PCI Slot.

DRAM Data Integrity Mode

This chipset support ECC, unbuffered DIMM. You can enable this function from setting this item.

The Choices: **Non-ECC**(default), ECC.

(**As using Non-ECC Dimms, the default is "Non-ECC. As using ECC DIMMs, the default is "ECC".)

P4TSG Pro BIOS Setup

5 Integrated Peripherals

■ Figure 5. Integrated Peripherals

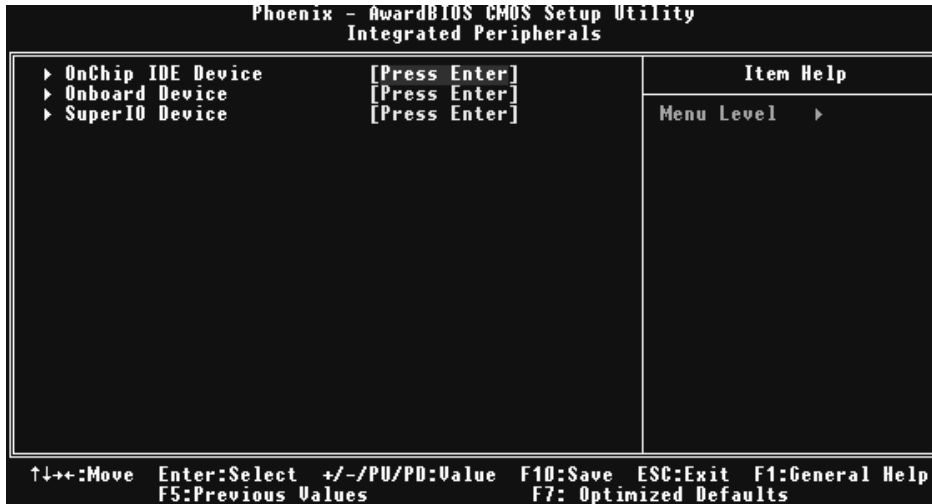

Onboard IDE Device

Press Enter to configure the onboard IDE Controllers.

IDE HDD Block Mode

Block mode is also called block transfer, multiple commands, or multiple sector read / write. If your IDE hard drive supports block mode (most new drives do), select Enabled for automatic detection of the optimal number of block mode (most new drives do), select Enabled for automatic detection of the optimal number of block read / write per sector where the drive can support.

The Choices: Enabled (default), Disabled.

On-Chip Primary/ Secondary PCI IDE

This item allows you to enable or disable the primary/ secondary IDE Channel.

The Choices: Enabled (Default), Disabled.

Primary / Secondary /Master / Slave PIO

The IDE PIO (Programmed Input / Output) fields let you set a PIO mode (0-4) for each of the IDE devices that the onboard IDE interface supports. Modes 0 to 4 will increase performance progressively. In Auto mode, the system automatically determines the best mode for each device.

The Choices: Auto (default), Mode0, Mode1, Mode2, Mode3, Mode4.

P4TSG Pro BIOS Setup

Primary / Secondary /Master / Slave UDMA

Ultra DMA/100 functionality can be implemented if it is supported by the IDE hard drives in your system. As well, your operating environment requires a DMA driver (Windows 95 OSR2 or a third party IDE bus master driver). If your hard drive and your system software both support Ultra DMA/100, select Auto to enable BIOS support.

The Choices: Auto (default), Disabled.

SATA Mode

The Choices: IDE(default).

On-Chip Serial ATA

This item allows you to enable or disable the On-Chip Serial ATA.

The Choices: Disabled(default).

Serial ATA Port0 Mode

The Choices: Primary Master(default).

Onboard Device

Press Enter to configure the onboard Device.

USB Controller

Select Enabled if your system contains a Universal Serial Bus (USB) controller and you have USB peripherals.

The Choices: Enabled (default), Disabled

USB 2.0 Controller

The Choices: disabled(default).

USB Keyboard/Mouse Support

This item allows you to enable or disable the USB Keyboard/ Mouse Legacy Support.

Enabled	Enable USB Keyboard/Mouse Support.
Disabled (default)	Disable USB Keyboard/Mouse Support.

AC97 Audio/ Modem

This item allows you to decide to enable/ disable to support AC97 Audio/Modem.

The Choices: Auto (default), Disabled.

VIA 1394 Controller(optional)

This item allows you to enable or disable the Onboard 1394 Controller.

The Choices: Enabled (default), Disabled.

VIA RAID Controller(optional)

This item allows you to enable or disable the Onboard Raid Controller.

P4TSG Pro BIOS Setup

The Choices: Enabled (default), Disabled.

Realtek Wireless LAN(optional)

This item allows you to enable or disable the Onboard Realtek Wireless Controller.

The Choices: Enabled (default), Disabled.

Wireless Function(optional)

This item allows you to switch the Wireless Function from Wireless Audio and Wireless Lan.

The Choices: Wireless Audio(default), Wireless LAN

CSA Gigabit Ethernet(optional)

This item allows you to enable or disable the CSA Gigabit Ethernet.

The Choices: Disabled (default), Enable.

Super IO Device

Press Enter to configure the Super I/O Device.

Power On Function

This item allows you to choose the power on function.

The Choices: Button (default), Password, Hot Key, Mouse Left, Mouse Right, Any Key, Keyboard 98.

KB Power on Password

Input password and press Enter to set the Keyboard power on password .

HOT Key power ON

Input password and press Enter to set the Keyboard power on password .

The Choices: Ctrl-F1(default) , Ctrl-F2 , Ctrl-F3 , Ctrl-F4 , Ctrl-F5, Ctrl-F6 , Ctrl-F7 , Ctrl-F8 , Ctrl-F9, Ctrl-F10 , Ctrl-F11 , Ctrl-F12 .

Onboard FDC Controller

Select Enabled if your system has a floppy disk controller (FDC) installed on the system board and you wish to use it. If install and FDC or the system has no floppy drive, select Disabled in this field.

The Choices: Enabled (default), Disabled.

Onboard Serial Port 1

Select an address and corresponding interrupt for the first and second serial ports.

The Choices: 3F8/IRQ4 (default), Disabled, Auto, 2F8/IRQ3, 3E8/IRQ4, 2E8/IRQ3.

Onboard Serial Port 2

Select an address and corresponding interrupt for the first and second serial ports

The Choices: 2F8/IRQ3, Disabled (default), Auto, 3F8/IRQ4 , 3E8/IRQ4, 2E8/IRQ3.

P4TSG Pro BIOS Setup

UART Mode Select

This item allows you to determine which Infrared (IR) function of onboard I/O chip.

The Choices: Normal(default), ASKIR, IrDA, SCR .

UR2 Duplex Mode

Select the value required by the IR device connected to the IR port. Full-duplex mode permits simultaneous two-direction transmission. Half-duplex mode permits transmission in one direction only at a time.

The Choices: Half (default), Full.

Onboard Parallel Port

This item allows you to determine access onboard parallel port controller with which I/O Address.

The Choices: 378/IRQ7 (default), 278/IRQ5, 3BC/IRQ7, Disabled.

ECP Mode Use DMA

Select a DMA Channel for the port.

The Choices: 3 (default), 1.

Power After Power Fail

This setting specifies whether your system will reboot after a power fail or interrupts occurs.

off Leaves the computer in the power off state.

on Reboots the computer.

Former-Sts Restores the system to the status before power failure or interrupt occurs.

The Choices: off(default), on, Former-Sts.

Game Port Address

Game Port I/O Address.

The Choices: 201 (default), 209, Disabled.

Midi Port Address

Midi Port Base I/O Address.

The Choices: 330 (default), 300, Disabled.

Midi Port IRQ

This determines the IRQ in which the Midi Port can use.

The Choices: 10 (default), 5.

P4TSG Pro BIOS Setup

6 Power Management Setup

The Power Management Setup Menu allows you to configure your system to utilize energy conservation and power up/power down features.

■ **Figure 6. Power Management Setup**

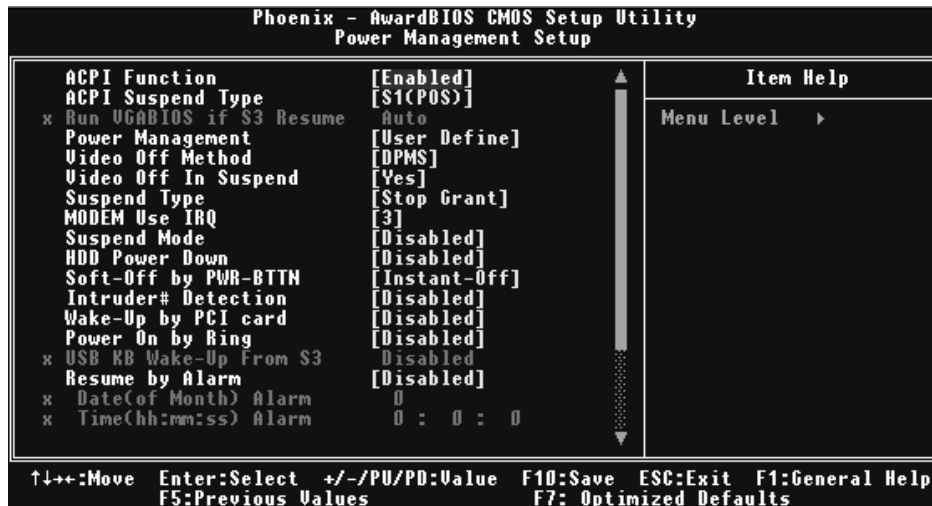

ACPI Function

This item displays the status of the Advanced Configuration and Power Management (ACPI).

The Choices: Enabled (default), Disabled.

ACPI Suspend Type

The item allows you to select the suspend type under the ACPI operating system.

The Choices: S1 (POS) (default) Power on Suspend
S3 (STR) Suspend to RAM
S1 & S3 POS+STR

Run VGABIOS if S3 Resume

Choosing Enabled will make BIOS run VGA BIOS to initialize the VGA card when system wakes up from S3 state. The system time is shortened if you disable the function, but system will need AGP driver to initialize the card. So, if the AGP driver of the VGA card does not support the initialization feature, the display may work abnormally or not function after S3.

The Choices: Auto (default), Yes, No.

P4TSG Pro BIOS Setup

Power Management

This category allows you to select the type (or degree) of power saving and is directly related to the following modes:

- 1.HDD Power Down.
- 2.Doze Mode.
- 3.Suspend Mode.

There are four options of Power Management, three of which have fixed mode settings

Min. Saving

Minimum power management.

Doze Mode = 1 hr.

Standby Mode = 1 hr

Suspend Mode = 1 hr.

HDD Power Down = 15 min

Max Saving

Maximum power management only available for sl CPU's.

Doze Mode = 1 min

Standby Mode = 1 min.

Suspend Mode = 1 min.

HDD Power Down = 1 min.

User Defined (default)

Allows you to set each mode individually.

When not disabled, each of the ranges are from 1 min. to 1 hr. except for HDD Power Down which ranges from 1 min. to 15 min. and disable.

Video Off Method

This option determines the manner in which the monitor is goes blank.

V/H SYNC+Blank

This selection will cause the system to turn off the vertical and horizontal synchronization ports and write blanks to the video buffer.

Blank Screen

This option only writes blanks to the video buffer.

DPMS (default)

Initial display power management signaling

P4TSG Pro BIOS Setup

Video Off In Suspend

This determines the manner in which the monitor is blanked.

The Choices: Yes (default), No.

Suspend Type

Select the Suspend Type.

The Choices: Stop Grant, **PwrOn Suspend** (default).

MODEM Use IRQ

This determines the IRQ, which can be applied in MODEM use.

The Choices:3 (default)

4 / 5 / 7 / 9 / 10 / 11 / NA

Suspend Mode

When enabled and after the set time of system inactivity, all devices except the CPU will be shut off.

The Choices: **Disabled** (default), 1Min, 2Min, 4Min, 8Min, 12Min, 20Min, 30Min, 40Min, 1Hour.

HDD Power Down

When enabled and after the set time of system inactivity, the hard disk drive will be powered down while all other devices remain active.

The Choices: **Disabled** (default), 1Min, 2Min, 3Min, 4Min, 5Min, 6Min, 7Min, 8Min, 9Min, 10Min, 11Min, 12Min, 13Min, 14Min, 15Min.

Soft-Off by PWR-BTTN

Pressing the power button for more than 4 seconds forces the system to enter the Soft-Off state when the system has "hung."

The Choices: Delay 4 Sec, **Instant-Off** (default).

Wake-Up by PCI card

When you select Enable, a PME signal from PCI card returns the system to Full On state.

The Choices: Enabled, **Disabled** (default).

Power On by Ring

An input signal on the serial Ring Indicator (RI) line (in other words, an incoming call on the modem) awakens the system from a soft off state.

The Choices: Enabled, **Disabled** (default).

P4TSG Pro BIOS Setup

Resume by Alarm

This function is for setting date and time for your computer to boot up. During Disabled, you cannot use this function. During Enabled, Choose the Date and Time.

Alarm: **Date (of Month) Alarm** You can choose which month the system will boot up.

Time (hh:mm:ss) Alarm You can choose what hour, minute and second the system will boot up.

Note: If you have change the setting, you must let the system boot up until it goes to the operating system, before this function will work.

P4TSG Pro BIOS Setup

7 PnP/PCI Configurations

This section describes configuring the PCI bus system. PCI, or Personal Computer Interconnect, is a system which allows I/O devices to operate at speeds nearing the speed of the CPU itself uses when communicating with its own special components. This section covers some very technical items and it is strongly recommended that only experienced users should make any changes to the default settings.

■ Figure 7. PnP/PCI Configurations

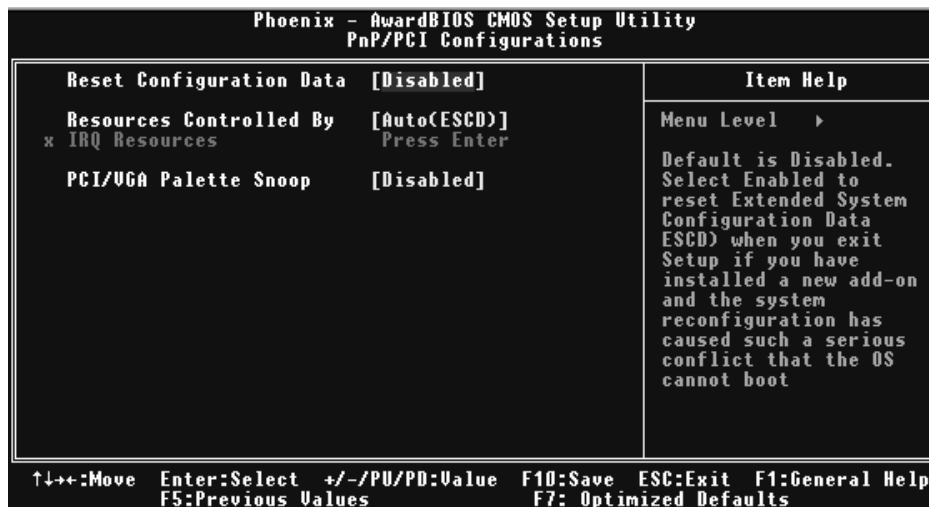

Reset Configuration Data

The system BIOS supports the PnP feature which requires the system to record which resources are assigned and protects resources from conflict. Every peripheral device has a node, which is called ESCD. This node records which resources are assigned to it. The system needs to record and update ESCD to the memory locations. These locations (4K) are reserved in the system BIOS. If the Disabled (default) option is chosen, the system's ESCD will update only when the new configuration varies from the last one. If the Enabled option is chosen, the system is forced to update ESCDs and then is automatically set to the "Disabled" mode.

The above settings will be shown on the screen only if "Manual" is chosen for the resources controlled by function.

Legacy is the term, which signifies that a resource is assigned to the ISA Bus and provides non-PnP ISA add-on cards. PCI / ISA PnP signifies that a resource is assigned to the PCI Bus or provides for ISA PnP add-on cards and peripherals.

The Choices: Disabled (default), Enabled.

P4TSG Pro BIOS Setup

Resources Controlled By

By Choosing “**Auto(ESCD)**” (default), the system BIOS will detect the system resources and automatically assign the relative IRQ and DMA channel for each peripheral. By Choosing “**Manual**”, the user will need to assign IRQ & DMA for add-on cards. Be sure that there are no IRQ/DMA and I/O port conflicts.

IRQ Resources

This submenu will allow you to assign each system interrupt a type, depending on the type of device using the interrupt. When you press the “Press Enter” tag, you will be directed to a submenu that will allow you to configure the system interrupts. This is only configurable when “Resources Controlled By” is set to “Manual”.

IRQ-3	assigned to	PCI Device
IRQ-4	assigned to	PCI Device
IRQ-5	assigned to	PCI Device
IRQ-7	assigned to	PCI Device
IRQ-9	assigned to	PCI Device
IRQ-10	assigned to	PCI Device
IRQ-11	assigned to	PCI Device
IRQ-12	assigned to	PCI Device
IRQ-14	assigned to	PCI Device
IRQ-15	assigned to	PCI Device

PCI / VGA Palette Snoop

Choose Disabled or Enabled. Some graphic controllers which are not VGA compatible take the output from a VGA controller and map it to their display as a way to provide boot information and VGA compatibility.

However, the color information coming from the VGA controller is drawn from the palette table inside the VGA controller to generate the proper colors, and the graphic controller needs to know what is in the palette of the VGA controller. To do this, the non-VGA graphic controller watches for the Write access to the VGA palette and registers the snoop data. In PCI based systems, where the VGA controller is on the PCI bus and a non-VGA graphic controller is on an ISA bus, the Write Access to the palette will not show up on the ISA bus if the PCI VGA controller responds to the Write.

In this case, the PCI VGA controller should not respond to the Write, it should only snoop the data and permit the access to be forwarded to the ISA bus. The non-VGA ISA graphic controller can then snoop the data on the ISA bus. Unless you have the above situation, you should disable this option.

Disabled (default)	Disables the function.
Enabled	Enables the function.

P4TSG Pro BIOS Setup

8 PC Health Status

■ Figure 8. PC Health Status

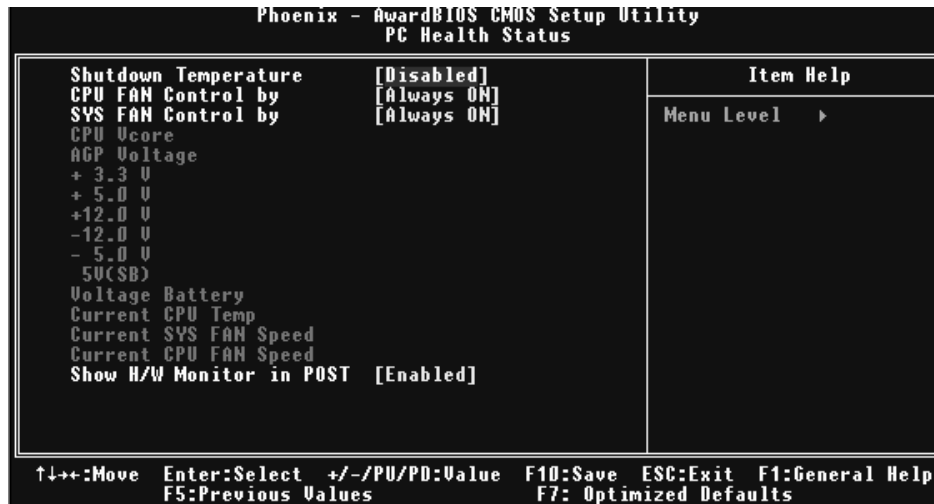

Shutdown Temperature

This item allows you to set up the CPU shutdown Temperature. This item only effective under Windows 98 ACPI mode.

The Choices: 60°C/140°F, 65°C/149°F, **Disabled** (default).

CPU FAN Control by

The Choice "smart" can make your CPU FAN to reduce noise.

The Choices: Always On(default), smart.

SYS FANControl by

The Choice "smart" can make your System FAN to reduce noise.

The Choices: Always On(default), smart.

CPU Vcore/ AGP Voltage/ +3.3V/ +5.0V/+12V/ -12V/ VBAT(V)/ 5VSB(V)

Detect the system's voltage status automatically.

P4TSG Pro BIOS Setup

Current CPU Temperature

Show you the current CPU temperature.

Current CPU FAN Speed

This field displays the current CPUFAN speed.

Current SYS FAN Speed

This field displays the current speed SYSTEM fan.

Show H/W Monitor in POST

If you computer contain a monitoring system, it will show PC health status during POST stage. The item offers several delay time to select you want.

The Choices: Enabled (default), Disabled .

P4TSG Pro BIOS Setup

9 Frequency Control

■ Figure 9. Frequency Control



CPU Clock Ratio

The Choices: **8 X**(default), 9X, 10X, 11X, 12X, 13X, 14 X, 15X, 16X, 17X, 18X, 19X, 20 X, 21 X, 22 X, 23 X.

CPU Voltage

This item allows you to select CPU Voltage Regulator.

The Choices: **2.5V** (default), +1.7%, +3.45%, +5.1%.

DIMM Voltage

This item allows you to select DDR Voltage Regulator.

The Choices: **2.5V** (Default), 2.6V, 2.7V, 2.8V.

Auto Detect PCI Clk

This item allows you to enable / disable auto Detect PCI Clock.

The Choices: **Enabled** (default), Disabled.

CPU Clock

This item allows you to select CPU Clock, and CPU over clocking.

P4TSG Pro BIOS Setup



If unfortunately, the system's frequency that you are selected is not functioning, there are two methods of booting-up the system.

Method 1: Clear the COMS data by setting the JCOMS1 ((2-3 closed)) as "ON" status. All the CMOS data will be loaded as defaults setting.

Method 2: Press the <Insert> key and Power button simultaneously, after that keep-on pressing the <Insert> key until the power-on screen showed. This action will boot-up the system according to FSB of the processor.

※ **It's strongly recommended to set CPU Vcore and clock in default setting. If the CPU Vcore and clock are not in default setting, it may cause CPU or M/B damage.**