

P4TDQ

FCC Statement and Copyright

This equipment has been tested and found to comply with the limits of a Class B digital device, pursuant to Part 15 of the FCC Rules. These limits are designed to provide reasonable protection against harmful interference in a residential installation. This equipment generates, uses and can radiate radio frequency energy and, if not installed and used in accordance with the instructions, may cause harmful interference to radio communications. There is no guarantee that interference will not occur in a particular installation.

The vendor makes no representations or warranties with respect to the contents here of and specially disclaims any implied warranties of merchantability or fitness for any purpose. Further the vendor reserves the right to revise this publication and to make changes to the contents here of without obligation to notify any party beforehand.

Duplication of this publication, in part or in whole is not allowed without first obtaining the vendor's approval in writing.

The content of this user's is subject to be changed without notice and we will not be responsible for any mistakes found in this user's manual. All the brand and product names are trademarks of their respective companies.

Contents

ENGLISH.....	1
P4TDQ Features.....	1
Package contents	1
Layout of P4TDQ	2
CPU Installation	3
DDR DIMM Modules: DDR1-2	4
Jumpers, Headers, Connectors & Slots	5
ESPAÑOL	9
Características del P4TDQ.....	9
Contenido del Paquete.....	9
Disposición del P4TDQ	10
Instalación de la CPU	11
Módulos DDR DIMM: DDR1-2	12
Conectores, Cabezales, Puentes y Ranuras	13
TROUBLE SHOOTING.....	17
SOLUCIÓN DE PROBLEMAS	18

Motherboard Description

English

P4TDQ Features

- ✦ Use Intel 82845GL/ 82801DB Chipset, ITE IT8712F, LAN Chip (optional).
- ✦ Contains on board I/O facilities, which include one serial port, a parallel port, a PS/2 mouse port, a PS/2 keyboard port, audio ports, USB ports, a LAN port (optional), a game port, and a monitor port.
- ✦ Supports the Intel Pentium 4[®] (Socket 478) processor up to 2.4GHz.
- ✦ Supports Ultra 100/66/33, BMIDE and PIO modes.
- ✦ Supports USB2.0 High Speed Device.
- ✦ Supports up to 2 DDR 200/266 MHz (without ECC) devices, running at 400 MHz Front Side Bus frequency.
- ✦ Supports one CNR Slot (Type A only), and three 32-bit PCI Bus slots.
- ✦ Complies with PC Micro-ATX form factor specifications.
- ✦ Supports popular operating systems such as Windows NT, Windows 2000, Windows ME, Windows XP, LINUX and SCO UNIX.
- ✦ Intel[®] AC'97 2.2 compatible.
- ✦ High S/N ratio meets PC 99 requirements.
- ✦ 4CH DAC, applicable for leading motherboard chipsets.
- ✦ Line-in phonejack share with rear out.

Package contents

- ✦ HDD Cable X 1, FDD Cable X 1, Fully Setup Driver CD X 1
- ✦ Flash Memory Writer for BIOS update X 1
- ✦ USB Cable X 2 (Optional)
- ✦ Rear I/O Panel for ATX Case X 1 (Optional)

Motherboard Description

Layout of P4TDQ

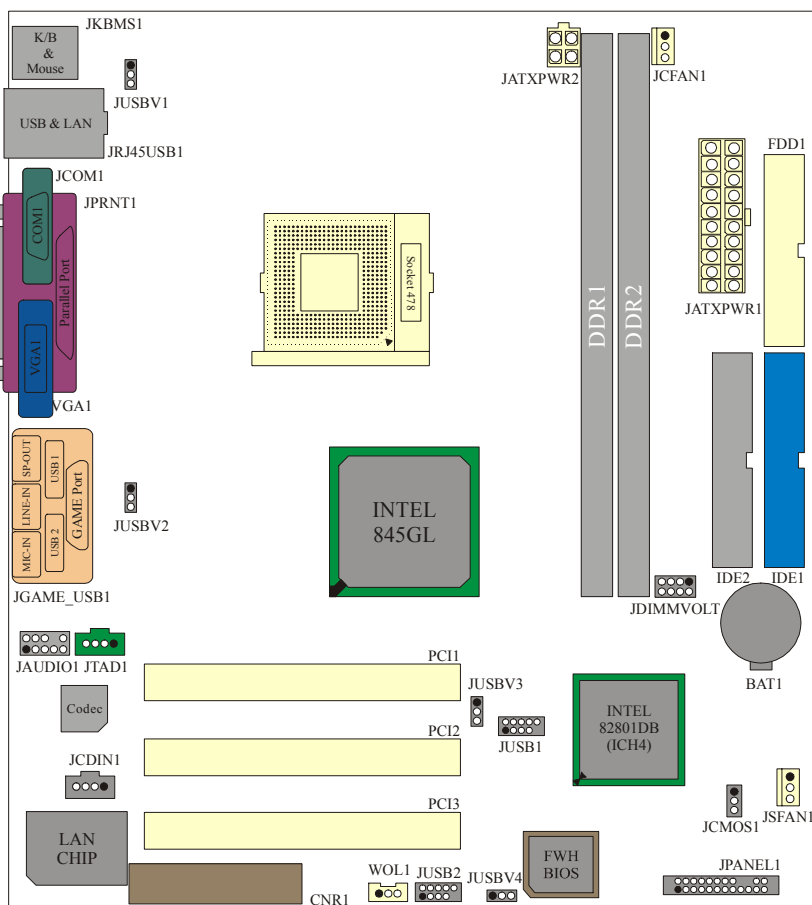

Motherboard Description

CPU Installation

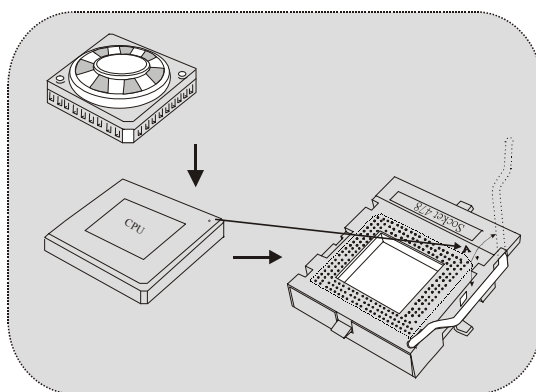

1. Pull the lever sideways away from the socket then raise the lever up to 90-degree angle.
2. Locate Pin A in the socket and lock for the white dot or cut edge in the CPU. Match Pin A with the white dot/cut edge then insert the CPU.
3. Press the lever down. Then Put the fan on the CPU and buckle it and put the fan's power port into the JCFAN1, then to complete the installation.

CPU/ System Fan Headers: JCFAN1/ JSFAN1

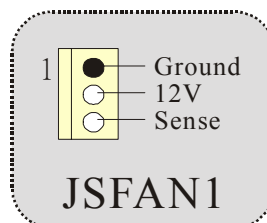
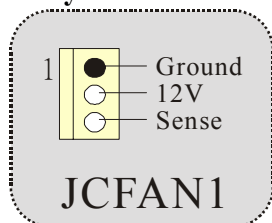

Motherboard Description

DDR DIMM Modules: DDR1-2

DRAM Access Time: 2.5V Unbuffered DDR 200/266 MHz Type required.

DRAM Type: 64MB/ 128MB/ 256MB/ 512MB/ 1GB DIMM Module (184 pin)

DIMM Socket Location	DDR Module	Total Memory Size (MB)
DDR 1	64MB/128MB/256MB/512MB/1GB *1	Max is 2GB
DDR 2	64MB/128MB/256MB/512MB/1GB *1	

* The list shown above for DRAM configuration is only for reference.

How to install a DIMM Module

1. The DIMM socket has a “Plastic Safety Tab”, and the DIMM memory module has an “Asymmetrical notch”, so the DIMM memory module can only fit into the slot in one direction.

2. Push the tabs out. Insert the DIMM memory modules into the socket at a 90-degree angle, then push down vertically so that it will fit into the place.

3. The Mounting Holes and plastic tabs should fit over the edge and hold the DIMM memory modules in place.

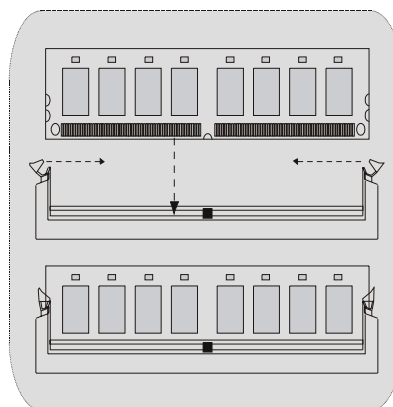

Motherboard Description

Jumpers, Headers, Connectors & Slots

Hard Disk Connectors: IDE1/ IDE2

The motherboard has a 32-bit Enhanced PCI IDE Controller that provides PIO Mode 0~4, Bus Master, and Ultra DMA / 33/ 66/ 100 functionality. It has two HDD connectors IDE1 (primary) and IDE2 (secondary).

The IDE connectors can connect a master and a slave drive, so you can connect up to four hard disk drives. The first hard drive should always be connected to IDE1.

Floppy Disk Connector: FDD1

The motherboard provides a standard floppy disk connector that supports 360K, 720K, 1.2M, 1.44M and 2.88M floppy disk types. This connector supports the provided floppy drive ribbon cables.

Communication Network Riser Slot: CNR1

The CNR specification is an open Industry Standard Architecture, and it defines a hardware scalable riser card interface, which supports audio, network and modem only.

Peripheral Component Interconnect Slots: PCI1-3

This motherboard is equipped with 3 standard PCI slots. PCI stands for Peripheral Component Interconnect, and it is a bus standard for expansion cards, which has, supplanted the older ISA bus standard in most ports. This PCI slot is designated as 32 bits.

Power Connectors: JATXPWR1/ JATXPWR2

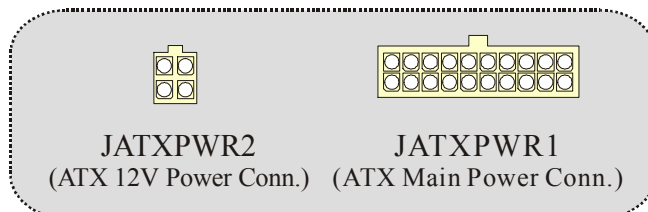

Motherboard Description

DIMM Power Selection Connector: JDIMMVOLT

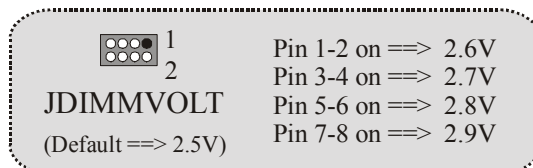

- It strongly recommended to set DDR DIMM voltage in default setting 2.5V, and it for over voltage function.

Wake On LAN Header: WOL1

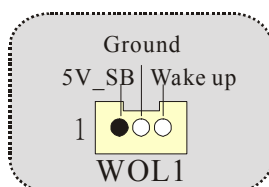

Front USB Header: JUSB1/ JUSB2

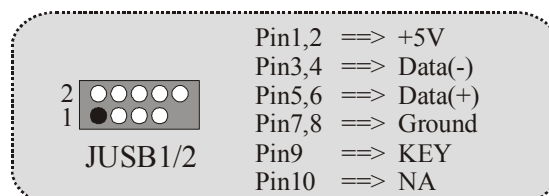

5V/ 5VSB Selection for USB: JUSBV1/ JUSB2-4 (Optional)

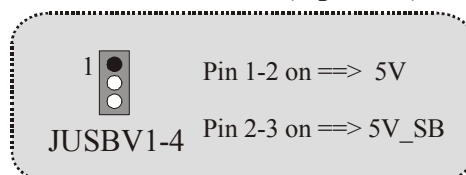

Motherboard Description

Front Panel Connector: JPANEL1

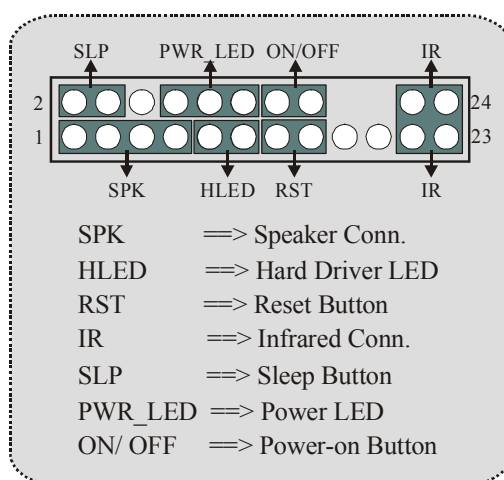

Audio Subsystem: JAUDIO1/ JTAD1(Optional)/JCDIN1

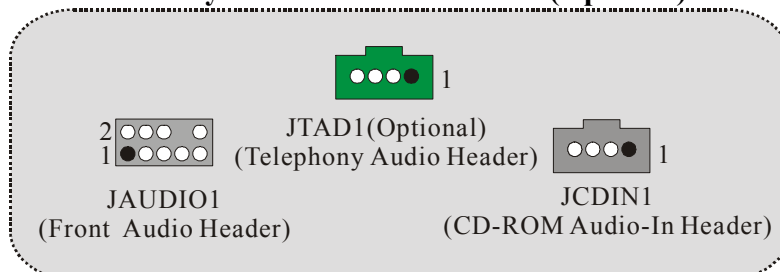

Motherboard Description

Clear CMOS Jumper: JCMOS1

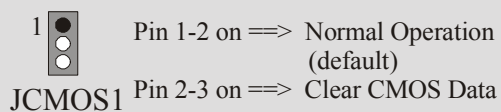

Back Panel Connectors

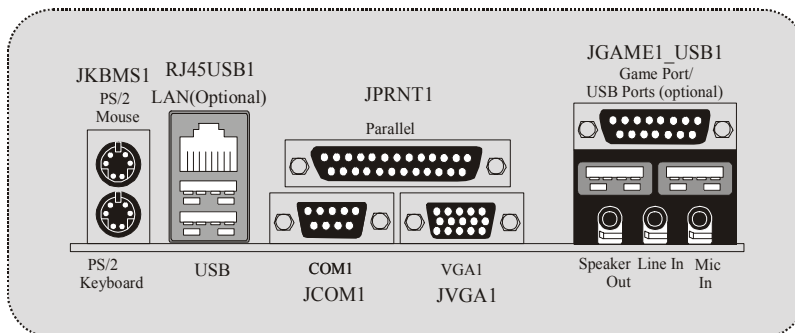

Motherboard Description

Español

Características del P4TDQ

- ✦ Usa Chipset Intel 82845GL/ 82801DB, ITE IT8712F, LAN Chip (opcional).
- ✦ Contiene facilidades I/O integrados en la placa madre en el que incluye un puerto en serie paralelo, un puerto paralelo, un puerto para el ratón PS/2, un puerto para teclado PS/2, puertos de audio, puertos USB, puerto LAN (opcional), un puerto para juegos y un puerto para el monitor.
- ✦ Soporta procesador Intel Pentium 4[®] (Socket 478) hasta 2.4GHz.
- ✦ Soporta Ultra 100/66/33, BMIDE y modo PIO.
- ✦ Soporta Dispositivo de Alta Velocidad USB2.0.
- ✦ Soporta hasta 2 DDR 200/266 MHz (no incluye ECC) dispositivos, corriendo a 400 MHz frecuencia Front Side Bus.
- ✦ Soporta una ranura CNR (solamente de tipo A), y tres ranuras PCI Bus de 32-bit.
- ✦ Compatible con la forma de PC Micro-ATX.
- ✦ Soporta sistemas operativos populares tales como Windows NT, Windows 2000, Windows ME, Windows XP, LINUX y SCO UNIX.
- ✦ Intel[®] AC'97 2.2 compatible.
- ✦ High S/N ratio meets PC 99 requirements.
- ✦ 4CH DAC, aplicable a los chipsets de la placa madre.
- ✦ Line-in phonejack compartido con el rear out.

Contenido del Paquete

- ✦ Cable HDD X 1, Cable FDD X 1, Completo Setup Driver CD X 1
- ✦ Memoria Flash Writer para actualización del BIOS X 1
- ✦ Cable USB X 2 (Opcional)
- ✦ Panel trasero I/O para caja ATX X 1 (Opcional)

Motherboard Description

Disposición del P4TDQ

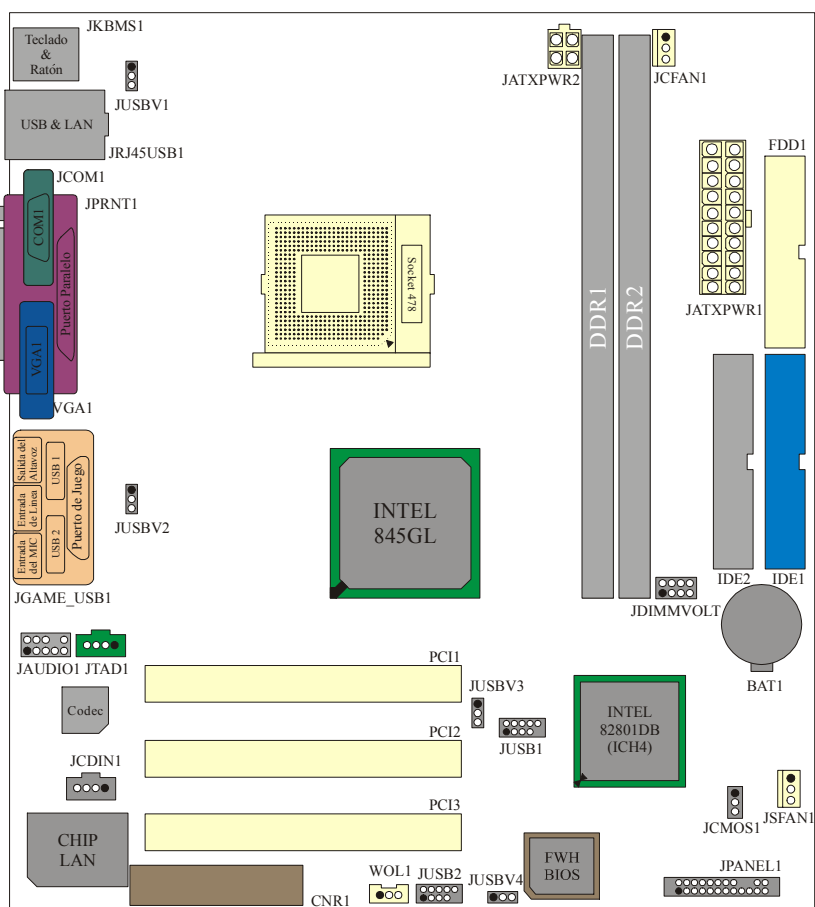

Motherboard Description

Instalación de la CPU

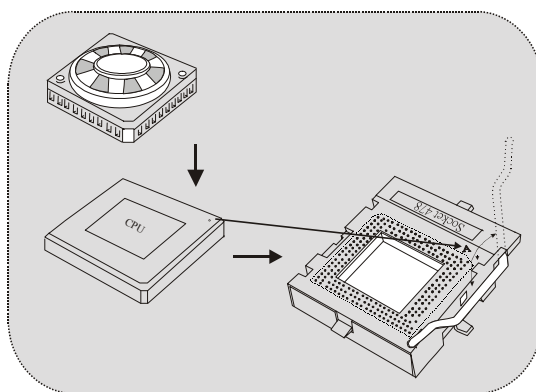

1. Tire de la palanca del lado del zócalo, luego levante la palanca hasta un ángulo de 90 grados.
2. Sitúe el contacto A del zócalo y busque el punto blanco o corte el borde en la CPU. Empareje el contacto A con el punto blanco/corte del borde, luego inserte la CPU.
3. Presione la palanca para abajo. Ponga el ventilador en la CPU y abróchelo. Luego ponga el puerto de corriente del ventilador en el JCFAN1. Y ya habrá completado su instalación.

CPU/ Cabezales del Sistemas de Ventilación: JCFAN1/ JSFAN1

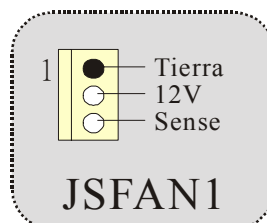
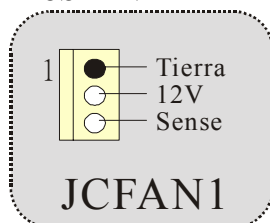

Motherboard Description

Módulos DDR DIMM: DDR1-2

DRAM Tiempo de Acceso: 2.5V Unbuffered DDR 200/266MHz Tipo requerido.

DRAM Tipo: 64MB/ 128MB/ 256MB/ 512MB/ 1GB Módulo DIMM (184 Contactos)

Localización del Zócalo DIMM	Módulo DDR	Total del Tamaño de Memoria (MB)
DDR 1	64MB/128MB/256MB/512MB/1GB *1	Máxima es 2GB
DDR 2	64MB/128MB/256MB/512MB/1GB *1	

* La lista de arriba para la configuración DRAM es solamente para referencia.

Cómo instalar un módulo DIMM

1. El zócalo DIMM tiene una lengüeta plástica de seguridad y el módulo de memoria DIMM tiene una muesca asimétrica, así el módulo de memoria DIMM puede caber solamente en la ranura de una sola dirección.

2. Tire la lengüeta hacia afuera. Inserte los módulos de memoria DIMM en el zócalo a los 90 grados, luego empuje hacia abajo verticalmente de modo que encaje en el lugar.

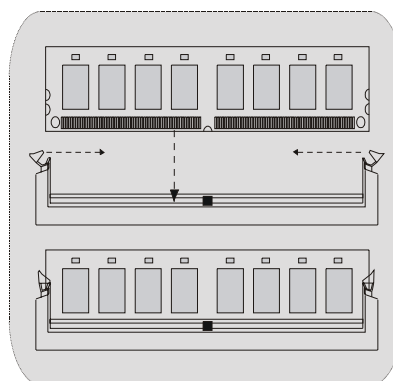

3. Los agujeros de montaje y las lengüetas plásticas deben caber por sobre el borde y sostenga los módulos de memoria DIMM en el lugar.

Motherboard Description

Conectores, Cabezales, Puentes y Ranuras

Conectores del Disco Duro: IDE1/ IDE2

La placa madre tiene un controlador de 32-bit PCI IDE que proporciona Modo PIO 0~4, Bus Master, y funcionalidad Ultra DMA / 33/ 66/ 100. Tiene dos conectores HDD IDE1 (primario) y IDE2 (secundario). El conector IDE puede conectar a un master y un drive esclavo, así puede conectar hasta cuatro discos rígidos. El primer disco duro debe estar siempre conectado al IDE1.

Conector para el Disquete: FDD1

La placa madre proporciona un conector estándar del disquete (FDC) que soporta 360K, 720K, 1.2M, 1.44M y 2.88M tipos de disquete. Éste conector utiliza los cables de cinta proporcionados por el disquete.

Ranura de Canalización de la Red de Comunicación:

CNR1

La especificación CNR es una abierta Industria Estándar de Arquitectura, y define una tarjeta hardware escalable de interface en el que soporta audio, red y módem.

Ranura de Interconexión del Componente Periférico:

PCI-3

Ésta placa madre está equipada con 3 ranuras PCI. PCI es la sigla para Interconexión del Componente Periférico, y es un estándar bus para la tarjeta de expansión en el que reemplaza, en su mayoría de las partes, al antiguo estándar ISA bus. Las ranuras de PCI están diseñadas con 32 bits

Conectores de Encendido: JATXPWR1/ JATXPWR2



JATXPWR2

(ATX 12V Conector de Corriente.)

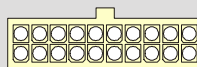

JATXPWR1

Motherboard Description

Conector de la Corriente de Selección DIMM: JDIMMVOLT

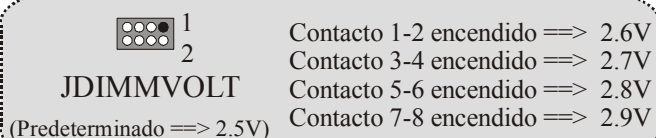

- Es fuertemente recomendado que fije el voltaje del DDR DIMM predeterminado en 2.5V, y sobre el sobre voltaje de función.

Cabezal Wake On LAN: WOL1

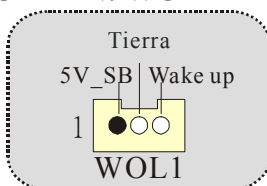

Cabezal Frontal USB: JUSB1/ JUSB2

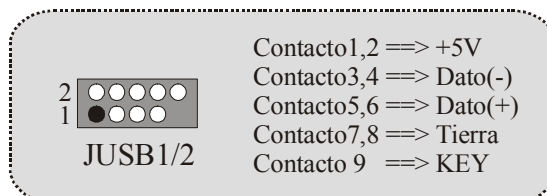

5V/ 5VSB Selección para USB: JUSBV1/ JUSB2-4 (Opcional)



Motherboard Description

Conector del Panel Frontal: JPANEL1

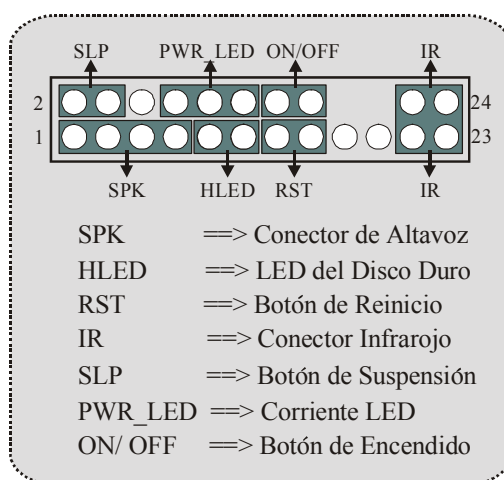

Subsistema de Audio: JAUDIO1/ JTAD1(Opcional)/JCDIN1



Motherboard Description

Puente de Borrar CMOS: JCMOS1

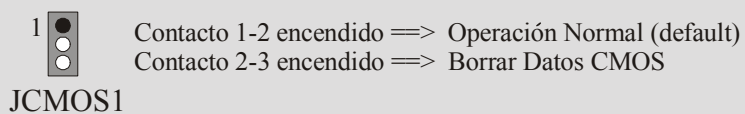

Conectores del Panel Trasero

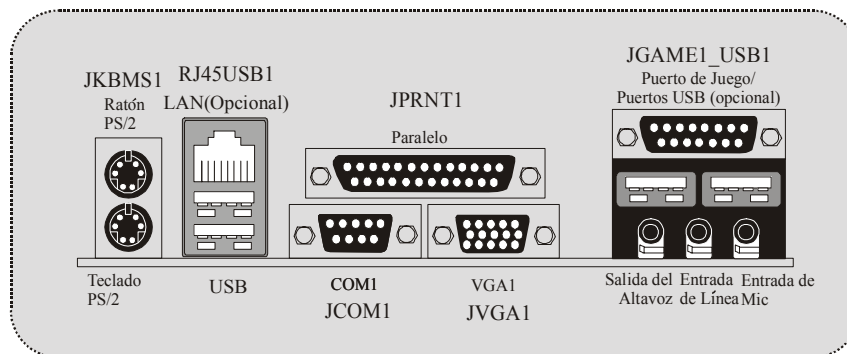

Trouble Shooting

PROBABLE	SOLUTION
No power to the system at all Power light don't illuminate, fan inside power supply does not turn on. Indicator light on keyboard does not turn on	<ul style="list-style-type: none"> * Make sure power cable is securely plugged in * Replace cable * Contact technical support
PROBABLE	SOLUTION
System inoperative. Keyboard lights are on, power indicator lights are lit, hard drive is spinning.	<ul style="list-style-type: none"> * Using even pressure on both ends of the DIMM, press down firmly until the module snaps into place.
PROBABLE	SOLUTION
System does not boot from hard disk drive, can be booted from CD-ROM drive.	<ul style="list-style-type: none"> * Check cable running from disk to disk controller board. Make sure both ends are securely plugged in; check the drive type in the standard CMOS setup. * Backing up the hard drive is extremely important. All hard disks are capable of breaking down at any time.
PROBABLE	SOLUTION
System only boots from CD-ROM. Hard disk can be read and applications can be used but booting from hard disk is impossible.	<ul style="list-style-type: none"> * Back up data and applications files. Reformat the hard drive. Re-install applications and data using backup disks.
PROBABLE	SOLUTION
Screen message says "Invalid Configuration" or "CMOS Failure."	<ul style="list-style-type: none"> * Review system's equipment . Make sure correct information is in setup.
PROBABLE	SOLUTION
Cannot boot system after installing second hard drive.	<ul style="list-style-type: none"> * Set master/slave jumpers correctly. * Run SETUP program and select correct drive types. Call drive manufacturers for compatibility with other drives.

Solución de Problemas

CAUSA PROBABLE	SOLUCIÓN
No hay corriente en el sistema. La luz de corriente no ilumina, ventilador dentro de la fuente de alimentación apagada. Indicador de luz del teclado apagado.	* Asegúrese que el cable de transmisión esté seguramente enchufado. * Reemplace el cable. * Contacte ayuda técnica.
CAUSA PROBABLE	SOLUCIÓN
Sistema inoperativo. Luz del teclado encendido, luz de indicador de corriente iluminado, disco rígido está girando.	* Presione los dos extremos del DIMM, presione para abajo firmemente hasta que el módulo encaje en el lugar.
CAUSA PROBABLE	SOLUCIÓN
Sistema no arranca desde el disco rígido, puede ser arrancado desde el CD-ROM drive.	* Controle el cable de ejecución desde el disco hasta el disco del controlador. Asegúrese de que ambos lados estén enchufados con seguridad; controle el tipo de disco en la configuración estándar CMOS. * Copiando el disco rígido es extremadamente importante. Todos los discos rígidos son capaces de dañarse en cualquier momento.
CAUSA PROBABLE	SOLUCIÓN
Sistema solamente arranca desde el CD-ROM. Disco rígido puede leer y aplicaciones pueden ser usados pero el arranque desde el disco rígido es imposible.	* Copie datos y documentos de aplicación. Vuelva a formatear el disco rígido. Vuelva a instalar las aplicaciones y datos usando el disco de copiado.
CAUSA PROBABLE	SOLUCIÓN
Mensaje de pantalla "Invalid Configuration" o "CMOS Failure."	* Revise el equipo del sistema. Asegúrese de que la información configurada sea correcta.
CAUSA PROBABLE	SOLUCIÓN
No puede arrancar después de instalar el segundo disco rígido.	* Fije correctamente el puente master/esclavo. * Ejecute el programa SETUP y seleccione el tipo de disco correcto. Llame a una manufacturación del disco para compatibilidad con otros discos.



04/24/2002

