

FCC Information and Copyright

This equipment has been tested and found to comply with the limits of a Class B digital device, pursuant to Part 15 of the FCC Rules. These limits are designed to provide reasonable protection against harmful interference in a residential installation. This equipment generates, uses and can radiate radio frequency energy and, if not installed and used in accordance with the instructions, may cause harmful interference to radio communications. There is no guarantee that interference will not occur in a particular installation.

The vendor makes no representations or warranties with respect to the contents here and specially disclaims any implied warranties of merchantability or fitness for any purpose. Further the vendor reserves the right to revise this publication and to make changes to the contents here without obligation to notify any party beforehand.

Duplication of this publication, in part or in whole, is not allowed without first obtaining the vendor's approval in writing.

The content of this user's manual is subject to be changed without notice and we will not be responsible for any mistakes found in this user's manual. All the brand and product names are trademarks of their respective companies.

Table of Contents

Chapter 1: INTRODUCTION	3
1.1 Before You Start.....	3
1.2 Package Checklist.....	3
1.3 Motherboard Features.....	4
1.4 Rear Panel Connectors (for Ver 5.x).....	6
1.5 Rear Panel Connectors (for Ver 6.x).....	6
1.6 Motherboard Layout (for Ver 5.x).....	7
1.7 Motherboard Layout (for Ver 6.x).....	8
Chapter 2: Hardware Installation	9
2.1 Installing Central Processing Unit (CPU).....	9
2.2 Fan Headers.....	11
2.3 Installing System Memory.....	12
2.4 Connectors and Slots.....	13
Chapter 3: Headers & Jumpers Setup	15
3.1 How to Setup Jumpers.....	15
3.2 Detail Settings.....	15
Chapter 4: USEFUL HELP	21
4.1 Driver Installation Note	21
4.2 Award BIOS Beep Code.....	22
4.3 Extra Information.....	22
4.4 Troubleshooting.....	24
Chapter 5: WarpSpeeder™	25
5.1 Introduction.....	25
5.2 System Requirement.....	25
5.3 Installation.....	26
5.4 WarpSpeeder™.....	27
Appendencies: SPEC In Other Language	34
German.....	34
France.....	36
Italian.....	38
Spanish.....	40
Portuguese.....	42
Polish.....	44
Russian.....	46
Arabic.....	48
Japanese.....	50

CHAPTER 1: INTRODUCTION

1.1 BEFORE YOU START

Thank you for choosing our product. Before you start installing the motherboard, please make sure you follow the instructions below:

- Prepare a dry and stable working environment with sufficient lighting.
- Always disconnect the computer from power outlet before operation.
- Before you take the motherboard out from anti-static bag, ground yourself properly by touching any safely grounded appliance, or use grounded wrist strap to remove the static charge.
- Avoid touching the components on motherboard or the rear side of the board unless necessary. Hold the board on the edge, do not try to bend or flex the board.
- Do not leave any unfastened small parts inside the case after installation. Loose parts will cause short circuits which may damage the equipment.
- Keep the computer from dangerous area, such as heat source, humid air and water.

1.2 PACKAGE CHECKLIST

- ✦ HDD Cable X 1
- ✦ User's Manual X 1
- ✦ Fully Setup Driver CD X 1
- ✦ Rear I/O Panel for ATX Case X 1
- ✦ FDD Cable X 1 (optional)
- ✦ Serial ATA Cable X 1 (optional)
- ✦ USB 2.0 Cable X1 (optional)
- ✦ S/PDIF Cable X 1 (optional)
- ✦ Serial ATA Power Cable X 1 (optional)

1.3 MOTHERBOARD FEATURES

	<i>Ver 5.x</i>	<i>Ver 6.x</i>
CPU	LGA 775 Intel Core2Duo/ Pentium 4/ Pentium D / Celeron D processor up to 3.8 GHz Supports Hyper Threading/ Execute Disable Bit/ Enhanced Intel SpeedStep®/ Intel Extended Memory 64 technology *It is recommended to use processors with 95W power consumption.	LGA 775 Intel Core2Duo/ Pentium 4/ Pentium D / Celeron D processor up to 3.8 GHz Supports Hyper Threading/ Execute Disable Bit/ Enhanced Intel SpeedStep®/ Intel Extended Memory 64 technology *It is recommended to use processors with 95W power consumption.
FSB	533 / 800 / 1066 MHz	533 / 800 / 1066 MHz
Chipset	VIA P4M900 VIA VT8237A	VIA P4M900 VIA VT8237A
Graphic	Chrome9 HC 3D / 2D Graphics Max Shared Video Memory is 256 MB	Chrome9 HC 3D / 2D Graphics Max Shared Video Memory is 256 MB
Super I/O	ITE 8712F Provides the most commonly used legacy Super I/O functionality. Low Pin Count Interface Environment Control initiatives, H/W Monitor Fan Speed Controller ITE's "Smart Guardian" function	ITE 8712F Provides the most commonly used legacy Super I/O functionality. Low Pin Count Interface Environment Control initiatives, H/W Monitor Fan Speed Controller ITE's "Smart Guardian" function
Main Memory	DIMM Slots x 2 Supports DDR2 533 / 667 Each DIMM supports 256/512MB/1GB/2GB DDR2 Max Memory Capacity 4GB Single Channel Mode DDR2 memory module Registered DIMM and ECC DIMM is not supported	DIMM Slots x 2 Supports DDR2 533 / 667 Each DIMM supports 256/512MB/1GB/2GB DDR2 Max Memory Capacity 4GB Single Channel Mode DDR2 memory module Registered DIMM and ECC DIMM is not supported
IDE	Integrated IDE Controller Ultra DMA 33~133 Bus Master Mode supports PIO Mode 0~4,	Integrated IDE Controller Ultra DMA 33~133 Bus Master Mode supports PIO Mode 0~4,
SATA	Integrated Serial ATA Controller Data transfer rates up to 1.5 Gb/s. SATA Version 1.0 specification compliant.	Integrated Serial ATA Controller Data transfer rates up to 1.5 Gb/s. SATA Version 1.0 specification compliant.

	<i>Ver 5.x</i>	<i>Ver 6.x</i>
LAN PHY	Realtek RTL 8201CL 10 / 100 Mb/s auto negotiation Half / Full duplex capability	Realtek RTL 8201CL 10 / 100 Mb/s auto negotiation Half / Full duplex capability
Sound Codec	ALC888 7.1 channels audio out High-Definition Audio support	ALC861VD 5.1 channels audio out High-Definition Audio support
Slots	PCI Express x 16 slot x1 PCI Express x 1 slot x1 PCI slot x2	PCI Express x 16 slot x1 PCI Express x 1 slot x1 PCI slot x2
On Board Connector	Floppy connector x1 IDE Connector x2 SATA Connector x2 Front Panel Connector x1 Front Audio Connector x1 CD-in Connector x1 S/PDIF out connector x1 CPU Fan header x1 System Fan header x1 Clear CMOS header x1 USB connector x2 Power Connector (24pin) x1 Power Connector (4pin) x1	Floppy connector x1 IDE Connector x2 SATA Connector x2 Front Panel Connector x1 Front Audio Connector x1 CD-in Connector x1 S/PDIF out connector x1 CPU Fan header x1 System Fan header x1 Clear CMOS header x1 USB connector x2 Power Connector (24pin) x1 Power Connector (4pin) x1
Back Panel I/O	PS/2 Keyboard x1 PS/2 Mouse x1 Serial Port x1 Printer Port x1 VGA Port x1 LAN port x1 USB Port x4 Audio Jack x6	PS/2 Keyboard x1 PS/2 Mouse x1 Serial Port x1 Printer Port x1 VGA Port x1 LAN port x1 USB Port x4 Audio Jack x3
Board Size	190 mm (W) x 244 mm (L)	190 mm (W) x 244 mm (L)
OS Support	Windows 2000 / XP / VISTA Biostar Reserves the right to add or remove support for any OS with or without notice.	Windows 2000 / XP / VISTA Biostar Reserves the right to add or remove support for any OS with or without notice.

1.4 REAR PANEL CONNECTORS (FOR VER 5.X)

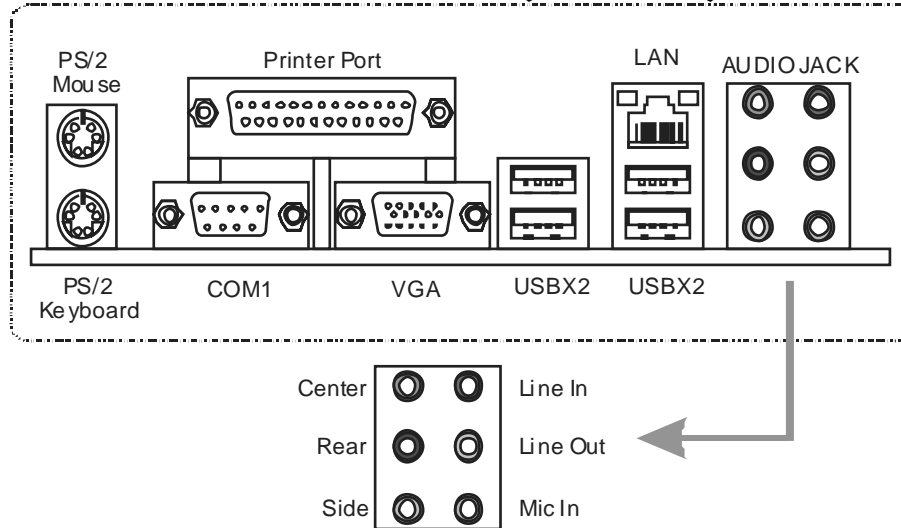

1.5 REAR PANEL CONNECTORS (FOR VER 6.X)

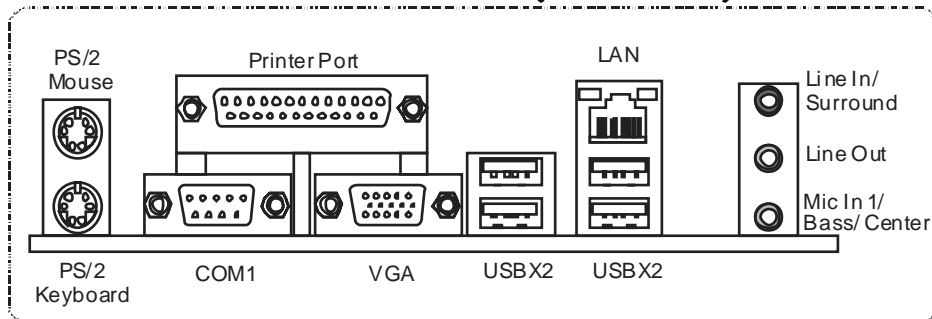

Since the audio chip supports High Definition Audio Specification, the function of each audio jack can be defined by software. The input/output function of each audio jack listed above represents the default setting. However, when connecting external microphone to the audio port, please use the Line In (blue) and Mic In (Pink) audio jack.

1.6 MOTHERBOARD LAYOUT (FOR VER 5.X)

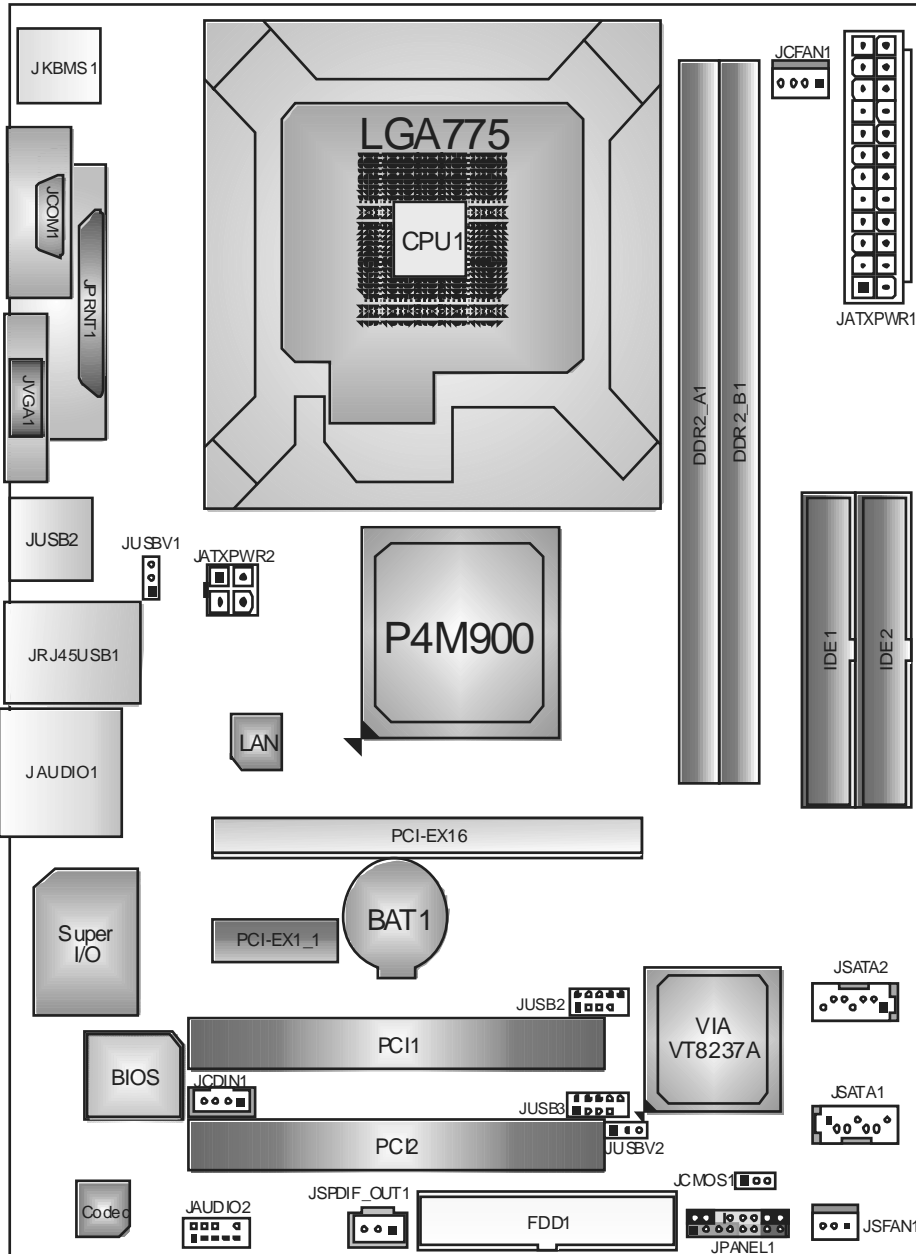

Note: ■ represents the 1st pin.

1.7 MOTHERBOARD LAYOUT (FOR VER 6.x)

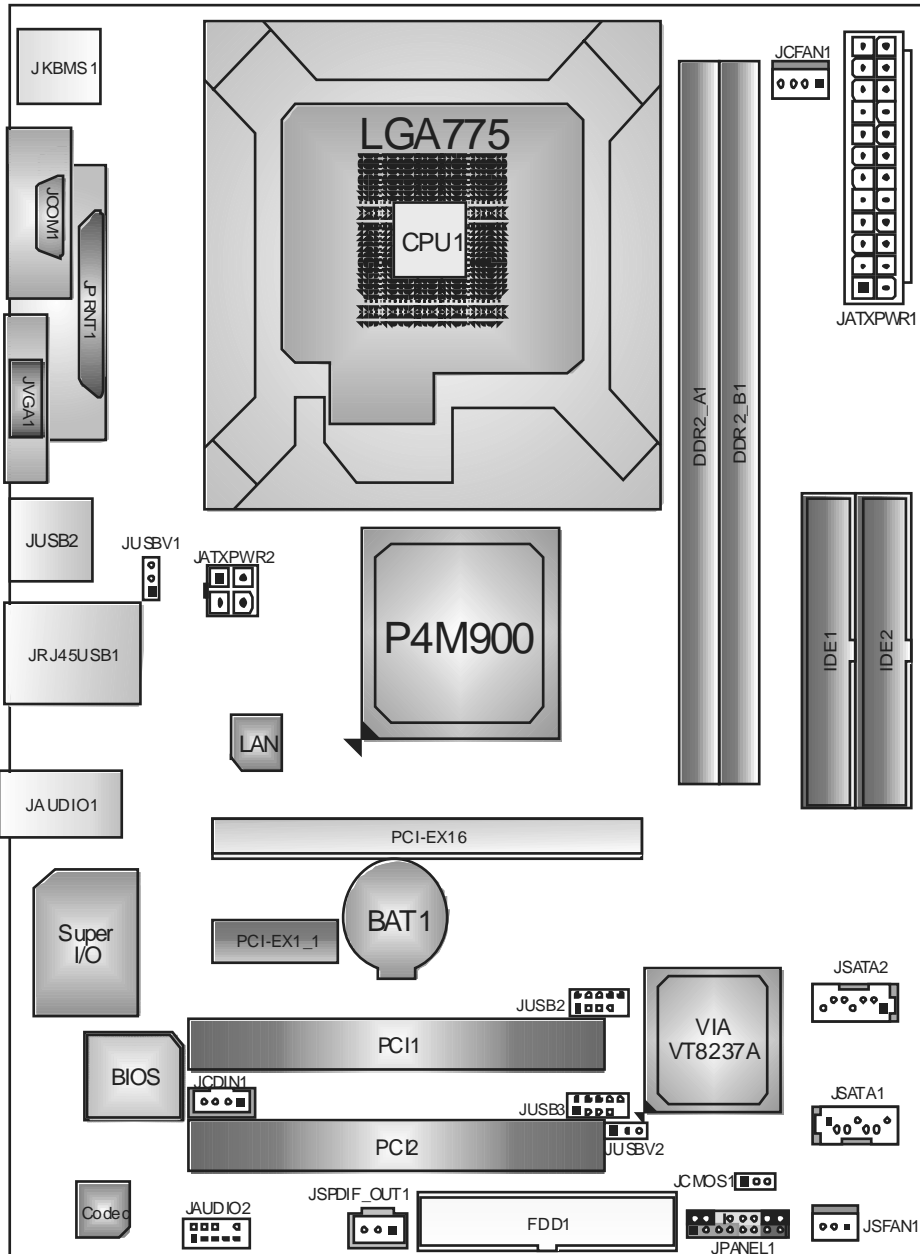

Note: ■ represents the 1st pin.

CHAPTER 2: HARDWARE INSTALLATION

2.1 INSTALLING CENTRAL PROCESSING UNIT (CPU)

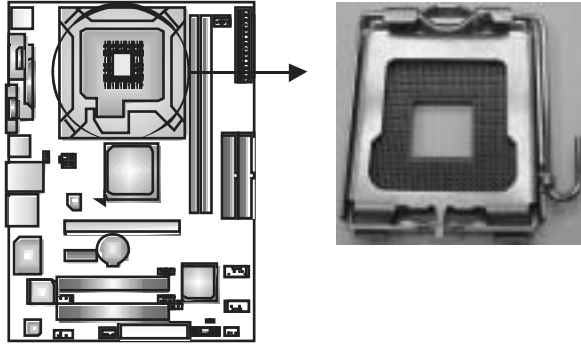

Special Notice

Remove Pin Cap before installation, and make good preservation for future use. When the CPU is removed, cover the Pin Cap on the empty socket to ensure pin legs won't be damaged.

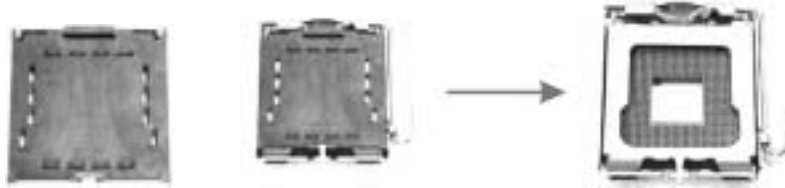

Pin Cap

Step 1: Pull the socket locking lever out from the socket and then raise the lever up to a 90-degree angle.

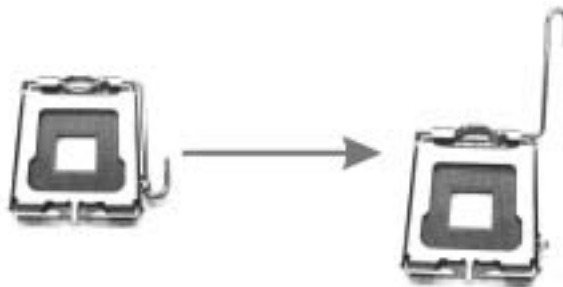

Step 2: Look for the triangular cut edge on socket, and the golden dot on CPU should point forwards this triangular cut edge. The CPU will fit only in the correct orientation.

Step 2-1:



Step 2-2:

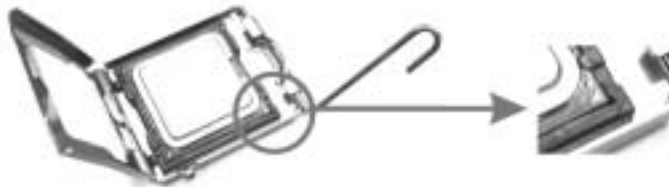

Step 3: Hold the CPU down firmly, and then lower the lever to locked position to complete the installation.



Step 4: Put the CPU Fan and heatsink assembly on the CPU and buckle it on the retention frame. Connect the CPU FAN power cable into the JCFAN1. This completes the installation.

2.2 FAN HEADERS

These fan headers support cooling-fans built in the computer. The fan cable and connector may be different according to the fan manufacturer. Connect the fan cable to the connector while matching the black wire to pin#1.

JCFAN1: CPU Fan Header

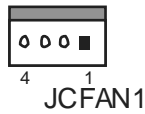
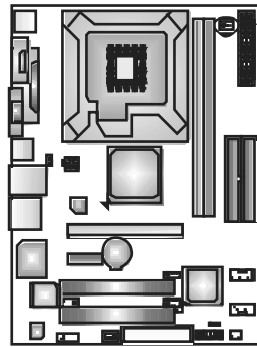

Pin	Assignment
1	Ground
2	+12V
3	FAN RPM rate sense
4	Smart Fan Control

JSFAN1: System Fan Header

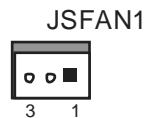
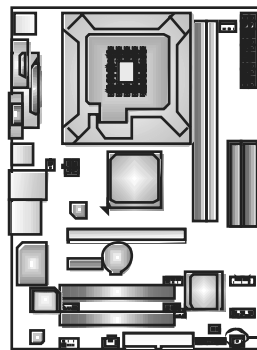

Pin	Assignment
1	Ground
2	+12V
3	FAN RPM rate sense

Note:

The JSFAN1 support 3-pin head connector. When connecting with wires onto connectors, please note that the red wire is the positive and should be connected to pin#2, and the black wire is Ground and should be connected to GND.

2.3 INSTALLING SYSTEM MEMORY

A. Memory Modules

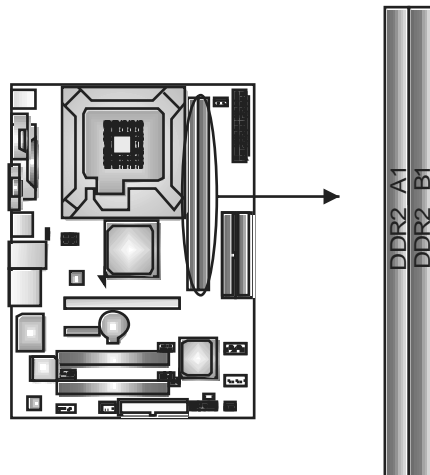

1. Unlock a DIMM slot by pressing the retaining clips outward. Align a DIMM on the slot such that the notch on the DIMM matches the break on the Slot.

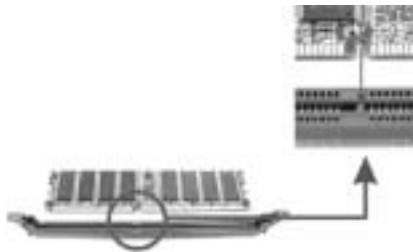

2. Insert the DIMM vertically and firmly into the slot until the retaining chip snap back in place and the DIMM is properly seated.

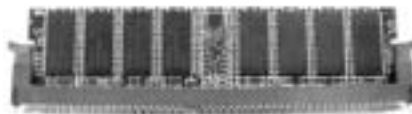

B. Memory Capacity

DIMM Socket Location	DDR Module	Total Memory Size
DDR2_A1	256MB/512MB/1GB/2GB	Max is 4GB.
DDR2_B1	256MB/512MB/1GB/2GB	

2.4 CONNECTORS AND SLOTS

FDD1: Floppy Disk Connector

The motherboard provides a standard floppy disk connector that supports 360K, 720K, 1.2M, 1.44M and 2.88M floppy disk types. This connector supports the provided floppy drive ribbon cables.

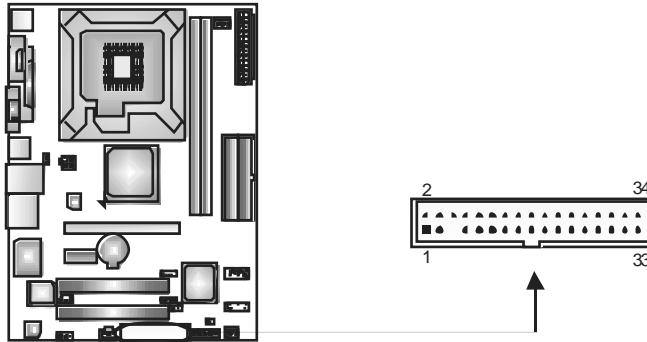

IDE1/IDE2: Hard Disk Connectors

The motherboard has a 32-bit Enhanced PCI IDE Controller that provides PIO Mode 0-4, Bus Master, and Ultra DMA 33/66/100/133 functionality. It has two HDD connectors IDE1 (primary) and IDE2 (secondary).

The IDE connectors can connect a master and a slave drive, so you can connect up to four hard disk drives. The first hard drive should always be connected to IDE1.

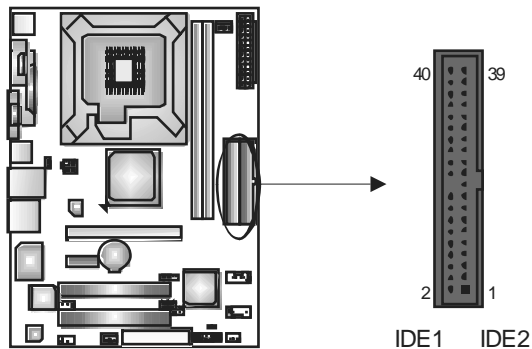

PCI-EX16: PCI-Express x16 Slot

- PCI-Express 1.0a compliant.
- Maximum theoretical realized bandwidth of 4GB/s simultaneously per direction, for an aggregate of 8GB/s totally.

PCI-EX1_1: PCI-Express x1 slots

- PCI-Express 1.0a compliant.
- Data transfer bandwidth up to 250MB/s per direction; 500MB/s in total.
- PCI-Express supports a raw bit-rate of 2.5Gb/s on the data pins.
- 2X bandwidth over the traditional PCI architecture.

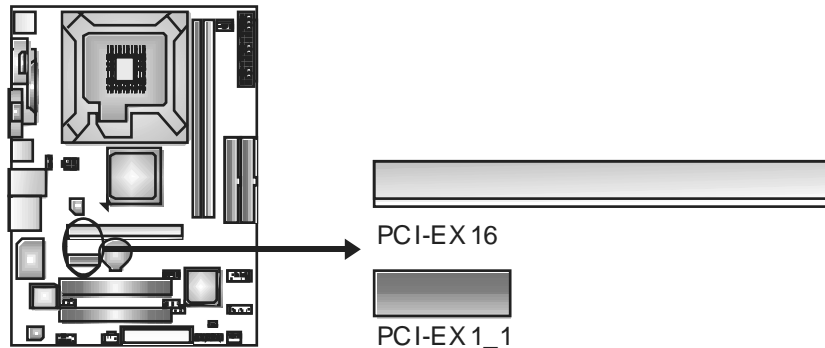

PCI1~PCI2: Peripheral Component Interconnect Slots

This motherboard is equipped with 2 standard PCI slots. PCI stands for Peripheral Component Interconnect, and it is a bus standard for expansion cards. This PCI slot is designated as 32 bits.

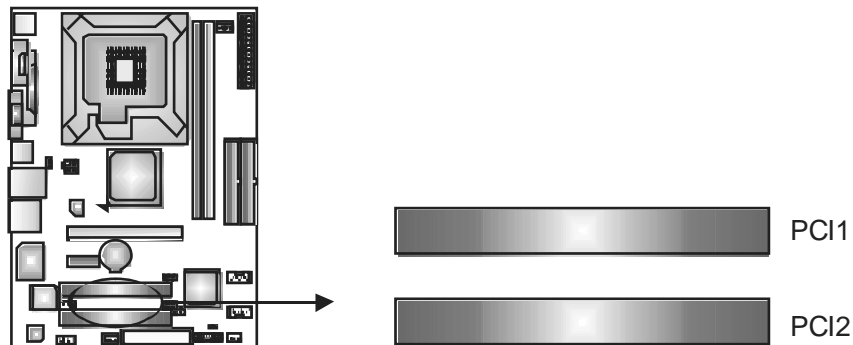

CHAPTER 3: HEADERS & JUMPERS SETUP

3.1 HOW TO SETUP JUMPERS

The illustration shows how to set up jumpers. When the jumper cap is placed on pins, the jumper is “close”, if not, that means the jumper is “open”.



3.2 DETAIL SETTINGS

JPANEL1: Front Panel Header

This 16-pin connector includes Power-on, Reset, HDD LED, Power LED, Sleep button and speaker connection. It allows user to connect the PC case's front panel switch functions.

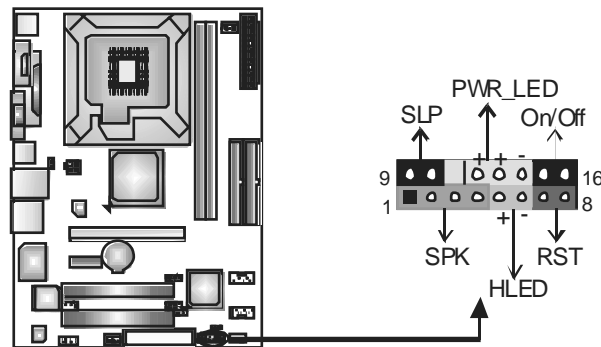

Pin	Assignment	Function	Pin	Assignment	Function
1	+5V	Speaker Connector	9	Sleep control	Sleep button
2	N/A		10	Ground	
3	N/A		11	N/A	N/A
4	Speaker		12	Power LED (+)	Power LED
5	HDD LED (+)	13	Power LED (+)		
6	HDD LED (-)	14	Power LED (-)		
7	Ground	Reset button	15	Power button	Power-on button
8	Reset control		16	Ground	

ATX Power Source Connector: JATXPWR1

JATXPWR1 allows user to connect 24-pin power connector on the ATX power supply.

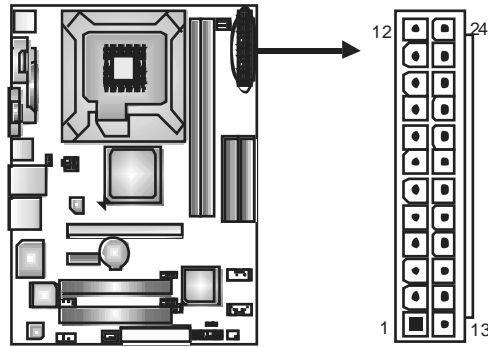

Pin	Assignment	Pin	Assignment
13	+3.3V	1	+3.3V
14	-12V	2	+3.3V
15	Ground	3	Ground
16	PS_ON	4	+5V
17	Ground	5	Ground
18	Ground	6	+5V
19	Ground	7	Ground
20	NC	8	PW_OK
21	+5V	9	Standby Voltage+5V
22	+5V	10	+12V
23	+5V	11	+12V
24	Ground	12	+3.3V

JATXPWR2: ATX Power Source Connector

By connecting this connector, it will provide +12V to CPU power circuit.

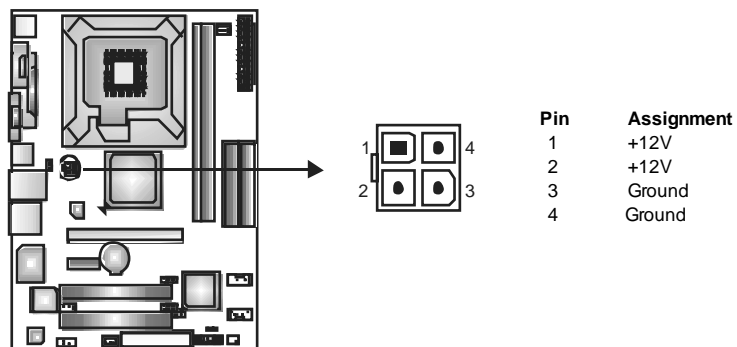

JUSB2/JUSB3: Headers for USB 2.0 Ports at Front Panel

This header allows user to connect additional USB cable on the PC front panel, and also can be connected with internal USB devices, like USB card reader.

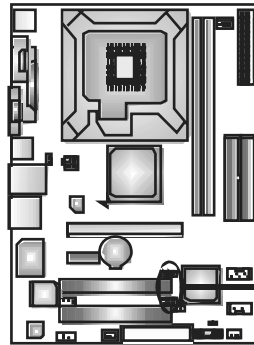

Pin	Assignment
1	+5V (fused)
2	+5V (fused)
3	USB-
4	USB-
5	USB+
6	USB+
7	Ground
8	Ground
9	Key
10	NC

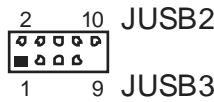

JUSBV1/JUSBV2: Power Source Headers for USB Ports

Pin 1-2 Close:

JUSBV1: +5V for USB ports at JRJ45USB1.

JUSBV2: +5V for USB ports at front panel (JUSB2/JUSB3).

Pin 2-3 Close:

JUSBV1: USB ports at JRJ45USB1 are powered by +5V standby voltage.

JUSBV2: USB ports at front panel (JUSB2/JUSB3) are powered by +5V standby voltage.

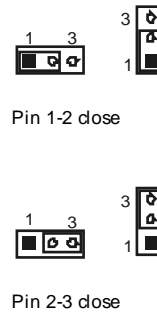
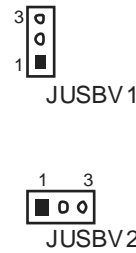
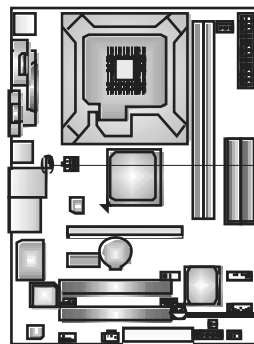

Note:

In order to support this function “Power-On system via a USB device,” “JUSBV1/ JUSBV2” jumper cap should be placed on Pin 2-3 individually

JAUDIO2: Front Panel Audio Header

This header allows user to connect the front audio output cable with the PC front panel. It will disable the output on back panel audio connectors.

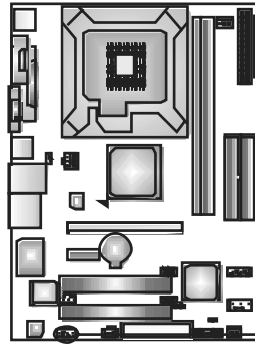

Pin	Assignment
1	Mic Left in
2	Ground
3	Mic Right in
4	GPIO
5	Right line in
6	Jack Sense
7	Front Sense
8	Key
9	Left line in
10	Jack Sense

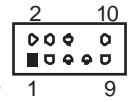

JCDIN1: CD-ROM Audio-in Connector

This connector allows user to connect the audio source from the variety devices, like CD-ROM, DVD-ROM, PCI sound card, PCI TV tuner card etc.

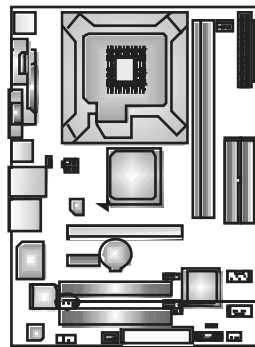

Pin	Assignment
1	Left Channel Input
2	Ground
3	Ground
4	Right Channel Input

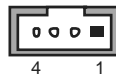

JCMOS1: Clear CMOS Header

By placing the jumper on pin2-3, it allows user to restore the BIOS safe setting and the CMOS data, please carefully follow the procedures to avoid damaging the motherboard.

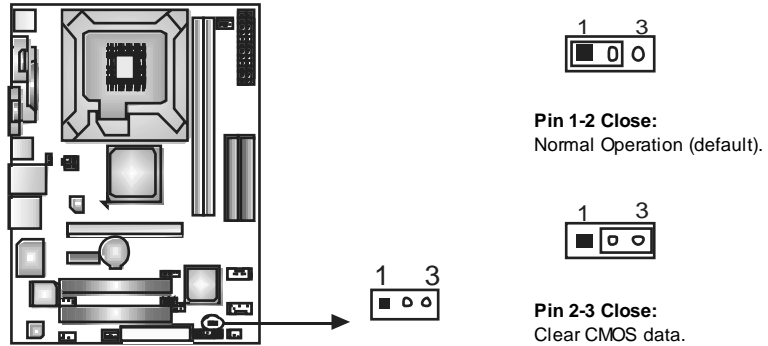

※ Clear CMOS Procedures:

1. Remove AC power line.
2. Set the jumper to "Pin 2-3 close".
3. Wait for five seconds.
4. Set the jumper to "Pin 1-2 close".
5. Power on the AC.
6. Reset your desired password or clear the CMOS data.

JSATA1~JSATA2: Serial ATA Connectors

The motherboard has a PCI to SATA Controller with 2 channels SATA interface, it satisfies the SATA 1.0 spec and with transfer rate of 1.5Gb/s.

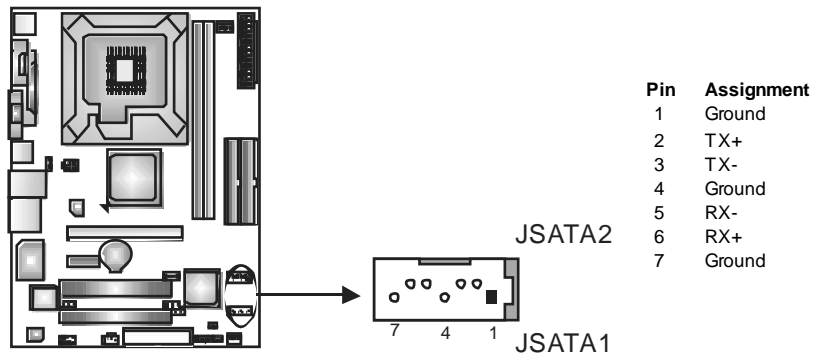

JSPDIF_OUT1: Digital Audio-out Connector

This connector allows user to connect the PCI bracket SPDIF output header.

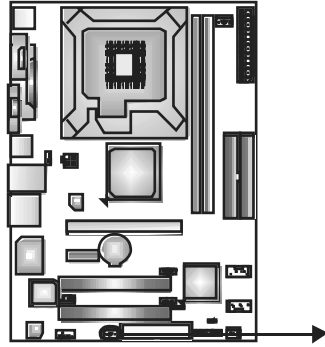

Pin	Assignment
1	+5V
2	SPDIF_OUT
3	Ground

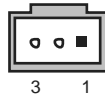

CHAPTER 4: USEFUL HELP

4.1 DRIVER INSTALLATION NOTE

After you installed your operating system, please insert the Fully Setup Driver CD into your optical drive and install the driver for better system performance.

You will see the following window after you insert the CD

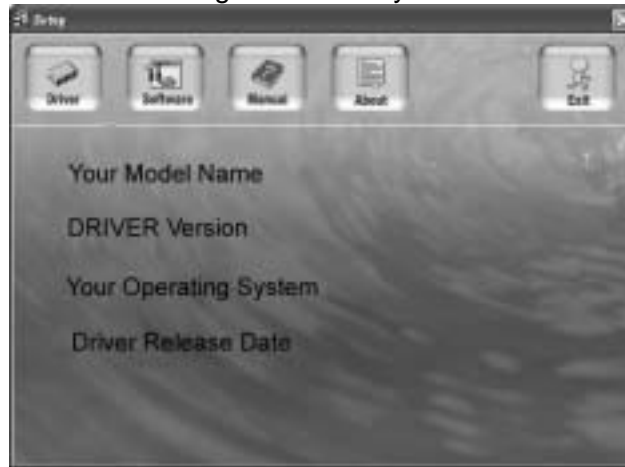

The setup guide will auto detect your motherboard and operating system.

Note:

If this window didn't show up after you insert the Driver CD, please use file browser to locate and execute the file **SETUPEXE** under your optical drive.

A. Driver Installation

To install the driver, please click on the Driver icon. The setup guide will list the compatible driver for your motherboard and operating system. Click on each device driver to launch the installation program.

B. Software Installation

To install the software, please click on the Software icon. The setup guide will list the software available for your system, click on each software title to launch the installation program.

C. Manual

Aside from the paperback manual, we also provide manual in the Driver CD. Click on the Manual icon to browse for available manual.

Note:

You will need Acrobat Reader to open the manual file. Please download the latest version of Acrobat Reader software from <http://www.adobe.com/products/acrobat/readstep2.html>

4.2 AWARD BIOS BEEP CODE

Beep Sound	Meaning
One long beep followed by two short beeps	Video card not found or video card memory bad
High-low siren sound	CPU overheated System will shut down automatically
One Short beep when system boot-up	No error found during POST
Long beeps every other second	No DRAM detected or install

4.3 EXTRA INFORMATION

A. BIOS Update

After you fail to update BIOS or BIOS is invaded by virus, the Boot-Block function will help to restore BIOS. If the following message is shown after boot-up the system, it means the BIOS contents are corrupted.



In this Case, please follow the procedure below to restore the BIOS:

1. Make a bootable floppy disk.
2. Download the Flash Utility "AWDFLASH.exe" from the Biostar website: www.biostar.com.tw
3. Confirm motherboard model and download the respectively BIOS from Biostar website.
4. Copy "AWDFLASH.exe" and respectively BIOS into floppy disk.
5. Insert the bootable disk into floppy drive and press Enter.
6. System will boot-up to DOS prompt.
7. Type "*Awdflash xxxx.bf/sn/py/r*" in DOS prompt.
(xxxx means BIOS name.)
8. System will update BIOS automatically and restart.
9. The BIOS has been recovered and will work properly.

B. CPU Overheated

If the system shutdown automatically after power on system for seconds, that means the CPU protection function has been activated.

When the CPU is over heated, the motherboard will shutdown automatically to avoid a damage of the CPU, and the system may not power on again.

In this case, please double check:

1. The CPU cooler surface is placed evenly with the CPU surface.
2. CPU fan is rotated normally.
3. CPU fan speed is fulfilling with the CPU speed.

After confirmed, please follow steps below to relief the CPU protection function.

1. Remove the power cord from power supply for seconds.
2. Wait for seconds.
3. Plug in the power cord and boot up the system.

Or you can:

1. Clear the CMOS data.
(See "Close CMOS Header: JCMOS1" section)
2. Wait for seconds.
3. Power on the system again.

4.4 TROUBLESHOOTING

Probable	Solution
<ol style="list-style-type: none"> No power to the system at all. Power light don't illuminate, fan inside power supply does not turn on. Indicator light on key board does not turn on. 	<ol style="list-style-type: none"> Make sure power cable is securely plugged in. Replace cable. Contact technical support.
System inoperative. Keyboard lights are on, power indicator lights are lit, and hard drive is spinning.	Using even pressure on both ends of the DIMM, press down firmly until the module snaps into place.
System does not boot from hard disk drive, can be booted from optical drive.	<ol style="list-style-type: none"> Check cable running from disk to disk controller board. Make sure both ends are securely plugged in; check the drive type in the standard CMOS setup. Backing up the hard drive is extremely important. All hard disks are capable of breaking down at any time.
System only boots from optical drive. Hard disk can be read and applications can be used but booting from hard disk is impossible.	<ol style="list-style-type: none"> Back up data and applications files. Reformat the hard drive. Re-install applications and data using backup disks.
Screen message says "Invalid Configuration" or "CMOS Failure."	Review system's equipment. Make sure correct information is in setup.
Cannot boot system after installing second hard drive.	<ol style="list-style-type: none"> Set master/slave jumpers correctly. Run SETUP program and select correct drive types. Call the drive manufacturers for compatibility with other drives.

CHAPTER 5: WARPSPEEDER™



5.1 INTRODUCTION

[WarpSpeeder™], a new powerful control utility, features three user-friendly functions including Overclock Manager, Overvoltage Manager, and Hardware Monitor.

With the Overclock Manager, users can easily adjust the frequency they prefer or they can get the best CPU performance with just one click. The Overvoltage Manager, on the other hand, helps to power up CPU core voltage and Memory voltage. The cool Hardware Monitor smartly indicates the temperatures, voltage and CPU fan speed as well as the chipset information. Also, in the About panel, you can get detail descriptions about BIOS model and chipsets. In addition, the frequency status of CPU, memory, AGP and PCI along with the CPU speed are synchronically shown on our main panel.

Moreover, to protect users' computer systems if the setting is not appropriate when testing and results in system fail or hang, [WarpSpeeder™] technology assures the system stability by automatically rebooting the computer and then restart to a speed that is either the original system speed or a suitable one.

5.2 SYSTEM REQUIREMENT

OS Support: Windows 98 SE, Windows Me, Windows 2000, Windows XP
DirectX: DirectX 8.1 or above. (The Windows XP operating system includes DirectX 8.1. If you use Windows XP, you do not need to install DirectX 8.1.)

5.3 INSTALLATION

1. Execute the setup execution file, and then the following dialog will pop up. Please click “Next” button and follow the default procedure to install.



2. When you see the following dialog in setup procedure, it means setup is completed. If the “Launch the WarpSpeeder Tray Utility” checkbox is checked, the Tray Icon utility and [WarpSpeeder™] utility will be automatically and immediately launched after you click “Finish” button.



Usage:

The following figures are just only for reference, the screen printed in this user manual will change according to your motherboard on hand.

5.4 WARPSPEDER™

1. **Tray Icon:**

Whenever the Tray Icon utility is launched, it will display a little tray icon on the right side of Windows Taskbar.

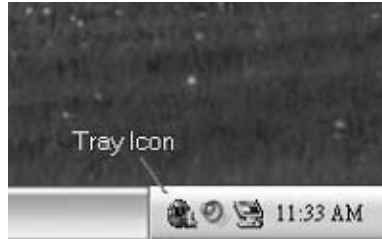

This utility is responsible for conveniently invoking [WarpSpeeder™] Utility. You can use the mouse by clicking the left button in order to invoke [WarpSpeeder™] directly from the little tray icon or you can right-click the little tray icon to pop up a popup menu as following figure. The “Launch Utility” item in the popup menu has the same function as mouse left-click on tray icon and “Exit” item will close Tray Icon utility if selected.



2. Main Panel

If you click the tray icon, [WarpSpeeder™] utility will be invoked. Please refer to the following figure; the utility's first window you will see is Main Panel.

Main Panel contains features as follows:

- Display the CPU Speed, CPU external dock, Memory dock, AGP dock, and PCI dock information.
- Contains About, Voltage, Overclock, and Hardware Monitor Buttons for invoking respective panels.
- With a user-friendly Status Animation, it can represent 3 overclock percentage stages:

Man walking → overclock percentage from 100% ~ 110 %

Panther running → overclock percentage from 110% ~ 120%

Car racing → overclock percentage from 120% ~ above

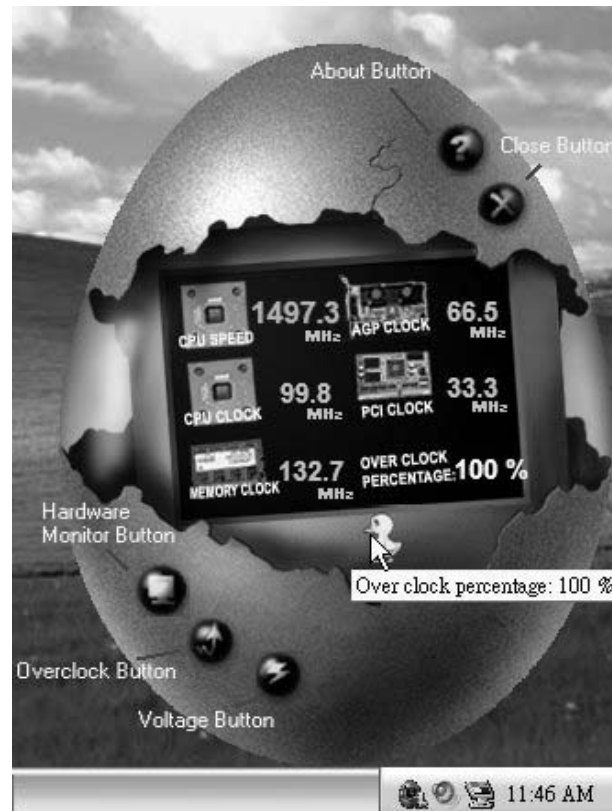

3. Voltage Panel

Click the Voltage button in Main Panel, the button will be highlighted and the Voltage Panel will slide out to up as the following figure.

In this panel, you can decide to increase CPU core voltage and Memory voltage or not. The default setting is "No". If you want to get the best performance of overlocking, we recommend you click the option "Yes".



4. Overclock Panel

Click the Overclock button in Main Panel, the button will be highlighted and the Overclock Panel will slide out to left as the following figure.



Overclock Panel contains the these features:

- “-3MHz button”, “-1MHz button”, “+1MHz button”, and “+3MHz button”:
provide user the ability to do real-time overclock adjustment.

Warning:

Manually overclock is potentially dangerous, especially when the overlocking percentage is over 110 %. We strongly recommend you verify every speed you overclock by click the Verify button. Or, you can just click Auto overclock button and let [WarpSpeeder™] automatically gets the best result for you.

- “Recovery Dialog button”:
Pop up the following dialog. Let user select a restoring way if system need to do a fail-safe reboot.



- c. “Auto-overclock button”: User can click this button and [WarpSpeeder™] will set the best and stable performance and frequency automatically. [WarpSpeeder™] utility will execute a series of testing until system fail. Then system will do fail-safe reboot by using Watchdog function. After reboot, the [WarpSpeeder™] utility will restore to the hardware default setting or load the verified best and stable frequency according to the Recovery Dialog's setting.
- d. “Verify button”: User can click this button and [WarpSpeeder™] will proceed a testing for current frequency. If the testing is ok, then the current frequency will be saved into system registry. If the testing fail, system will do a fail-safe rebooting. After reboot, the [WarpSpeeder™] utility will restore to the hardware default setting or load the verified best and stable frequency according to the Recovery Dialog's setting.

Note:

Because the testing programs, invoked in Auto-overclock and Verify, include DirectDraw, Direct3D and DirectShow tests, the DirectX 8.1 or newer runtime library is required. And please make sure our display card's color depth is High color (16 bit) or True color (24/32 bit) that is required for Direct3D rendering.

5. Hardware Monitor Panel

Click the Hardware Monitor button in Main Panel, the button will be highlighted and the Hardware Monitor panel will slide out to left as the following figure.

In this panel, you can get the real-time status information of your system. The information will be refreshed every 1 second.



6. About Panel

Click the “about” button in Main Panel, the button will be highlighted and the About Panel will slide out to up as the following figure.

In this panel, you can get model name and detail information in hints of all the chipset that are related to overclocking. You can also get the mainboard’s BIOS model and the Version number of [WarpSpeeder™] utility.

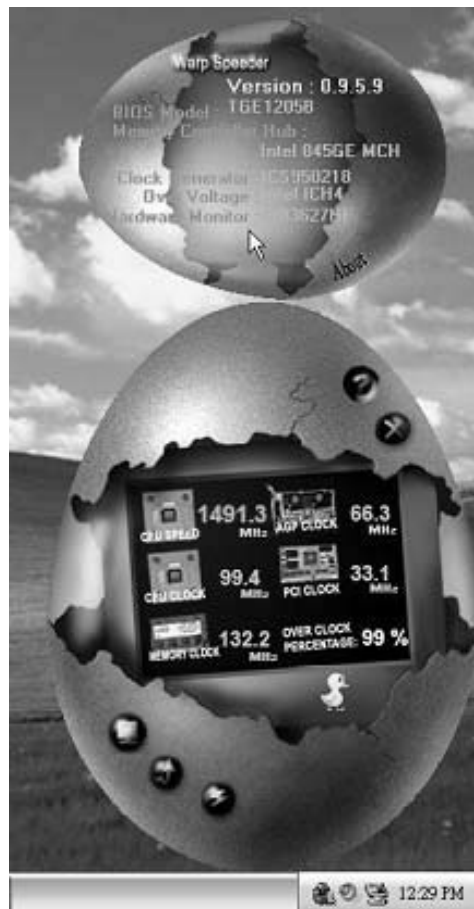

Note:

Because the overclock, overvoltage, and hardware monitor features are controlled by several separate chipset, [WarpSpeeder™] divide these features to separate panels. If one chipset is not on board, the correlative button in Main panel will be disabled, but will not interfere other panels’ functions. This property can make [WarpSpeeder™] utility more robust.

This page is intentionally left blank

APPENDENCIES: SPEC IN OTHER LANGUAGE**GERMAN**

	<i>Ver 5.x</i>	<i>Ver 6.x</i>
CPU	LGA 775 Intel Core2Duo/ Pentium 4 / Pentium D / Celeron D Prozessoren mit bis zu 3,8 GHz Unterstützt Hyper-Threading / Execute Disable Bit / Enhanced Intel SpeedStep® / Intel Architecture-64 / Extended Memory 64 Technology *It is recommended to use processors with 95W power consumption.	LGA 775 Intel Core2Duo/ Pentium 4 / Pentium D / Celeron D Prozessoren mit bis zu 3,8 GHz Unterstützt Hyper-Threading / Execute Disable Bit / Enhanced Intel SpeedStep® / Intel Architecture-64 / Extended Memory 64 Technology *It is recommended to use processors with 95W power consumption.
FSB	533 / 800 / 1066 MHz	533 / 800 / 1066 MHz
Chipsatz	VIA P4M900 VIA VT8237A	VIA P4M900 VIA VT8237A
Grafik	Chrome9 HC 3D / 2D Graphics Max. 256MB gemeinsam benutzter Videospeicher	Chrome9 HC 3D / 2D Graphics Max. 256MB gemeinsam benutzter Videospeicher
Super E/A	ITE 8712F Bietet die häufig verwendeten alten Super E/A-Funktionen. Low Pin Count-Schnittstelle Umgebungskontrolle, Hardware-Überwachung Lüfterdrehzahl-Controller "Smart Guardian"-Funktion von ITE	ITE 8712F Bietet die häufig verwendeten alten Super E/A-Funktionen. Low Pin Count-Schnittstelle Umgebungskontrolle, Hardware-Überwachung Lüfterdrehzahl-Controller "Smart Guardian"-Funktion von ITE
Arbeitsspeicher	DDR2 DIMM-Steckplätze x 2 Unterstützt DDR2 533 / 667 Jeder DIMM unterstützt 256/512MB/1GB/2GB DDR2. Max. 4GB Arbeitsspeicher Ein-Kanal DDR2 Speichermodul registrierte DIMMs. ECC DIMMs werden nicht unterstützt.	DDR2 DIMM-Steckplätze x 2 Unterstützt DDR2 533 / 667 Jeder DIMM unterstützt 256/512MB/1GB/2GB DDR2. Max. 4GB Arbeitsspeicher Ein-Kanal DDR2 Speichermodul registrierte DIMMs. ECC DIMMs werden nicht unterstützt.
IDE	Integrierter IDE-Controller Ultra DMA 33 / 66 / 100 / 133Bus Master-Modus Unterstützt PIO-Modus 0~4,	Integrierter IDE-Controller Ultra DMA 33 / 66 / 100 / 133Bus Master-Modus Unterstützt PIO-Modus 0~4,
SATA	Integrierter Serial ATA-Controller Datentransfer rate bis zu 1.5Gb/s Konform mit der SATA-Spezifikation Version 1.0.	Integrierter Serial ATA-Controller Datentransfer rate bis zu 1.5Gb/s Konform mit der SATA-Spezifikation Version 1.0.

	Ver 5.x	Ver 6.x
LAN PHY	Realtek RTL 8201CL 10 / 100 Mb/s Auto-Negotiation Halb-/ Vollduplex-Funktion	Realtek RTL 8201CL 10 / 100 Mb/s Auto-Negotiation Halb-/ Vollduplex-Funktion
Audio-Codec	ALC888 Unterstützt High-Definition Audio 7.1-Kanal-Audioausgabe	ALC861VD Unterstützt High-Definition Audio 5.1-Kanal-Audioausgabe
Steckplätze	PCI-Steckplatz x2 PCI Express x16 Steckplatz x1 PCI Express x1-Steckplatz x1	PCI-Steckplatz x2 PCI Express x16 Steckplatz x1 PCI Express x1-Steckplatz x1
Onboard-Anschluss	Diskettenlaufwerkanschluss x1 IDE-Anschluss x2 SATA-Anschluss x2 Fronttafelanschluss x1 Front-Audioanschluss x1 CD-IN-Anschluss x1 S/PDIF-Ausgangsanschluss x1 CPU-Lüfter-Sockel x1 System-Lüfter-Sockel x1 "CMOS löschen"-Sockel x1 USB-Anschluss x2 Stromanschluss (24-polig) x1 Stromanschluss (4-polig) x1	Diskettenlaufwerkanschluss x1 IDE-Anschluss x2 SATA-Anschluss x2 Fronttafelanschluss x1 Front-Audioanschluss x1 CD-IN-Anschluss x1 S/PDIF-Ausgangsanschluss x1 CPU-Lüfter-Sockel x1 System-Lüfter-Sockel x1 "CMOS löschen"-Sockel x1 USB-Anschluss x2 Stromanschluss (24-polig) x1 Stromanschluss (4-polig) x1
Rückseiten-E/A	PS/2-Tastatur x1 PS/2-Maus x1 Serieller Anschluss x1 Druckeranschluss x1 VGA-Anschluss x1 LAN-Anschluss x1 USB-Anschluss x4 Audioanschluss x6	PS/2-Tastatur x1 PS/2-Maus x1 Serieller Anschluss x1 Druckeranschluss x1 VGA-Anschluss x1 LAN-Anschluss x1 USB-Anschluss x4 Audioanschluss x3
Platinengröße.	190 mm (B) X 244 mm (L)	190 mm (B) X 244 mm (L)
OS-Unterstützung	Windows 2K / XP / VISTA Biostar behält sich das Recht vor, ohne Ankündigung die Unterstützung für ein Betriebssystem hinzuzufügen oder zu entfernen.	Windows 2K / XP / VISTA Biostar behält sich das Recht vor, ohne Ankündigung die Unterstützung für ein Betriebssystem hinzuzufügen oder zu entfernen.

FRANCE

	<i>Ver 5.x</i>	<i>Ver 6.x</i>
UC	LGA 775 Processeurs Intel Core2Duo/ Pentium 4 / Pentium D / Celeron D jusqu'à 3,8 GHz Prend en charge les technologies Hyper-Threading / d'exécution de bit de désactivation / Intel SpeedStep® optimisée/ d'architecture Intel 64 / de mémoire étendue 64 *It is recommended to use processors with 95W power consumption.	LGA 775 Processeurs Intel Core2Duo/ Pentium 4 / Pentium D / Celeron D jusqu'à 3,8 GHz Prend en charge les technologies Hyper-Threading / d'exécution de bit de désactivation / Intel SpeedStep® optimisée/ d'architecture Intel 64 / de mémoire étendue 64 *It is recommended to use processors with 95W power consumption.
Bus frontal	533 / 800 / 1066 MHz	533 / 800 / 1066 MHz
Chipset	VIA P4M900 VIA VT8237A	VIA P4M900 VIA VT8237A
Graphiques	Chrome9 HC 3D / 2D Graphics Mémoire vidéo partagée maximale de 256 Mo	Chrome9 HC 3D / 2D Graphics Mémoire vidéo partagée maximale de 256 Mo
Super E/S	ITE 8712F Fournit la fonctionnalité de Super E/S patrimoniales la plus utilisée. Interface à faible compte de broches Initiatives de contrôle environnementales, Moniteur de matériel Contrôleur de vitesse de ventilateur Fonction "Gardien intelligent" de l'ITE	ITE 8712F Fournit la fonctionnalité de Super E/S patrimoniales la plus utilisée. Interface à faible compte de broches Initiatives de contrôle environnementales, Moniteur de matériel Contrôleur de vitesse de ventilateur Fonction "Gardien intelligent" de l'ITE
Mémoire principale	Fentes DDR 2 DIMM x 2 Prend en charge la DDR 2 533 / 667 Chaque DIMM prend en charge des DDR2 de 256 Mo / 512 Mo / 1Go / 2 Go Capacité mémoire maximale de 4 Go Module de mémoire DDR2 à mode à simple voie Les DIMM à registres et DIMM sans code correcteurs d'erreurs sont pas prises en charge	Fentes DDR 2 DIMM x 2 Prend en charge la DDR 2 533 / 667 Chaque DIMM prend en charge des DDR2 de 256 Mo / 512 Mo / 1Go / 2 Go Capacité mémoire maximale de 4 Go Module de mémoire DDR2 à mode à simple voie Les DIMM à registres et DIMM sans code correcteurs d'erreurs sont pas prises en charge
IDE	Contrôleur IDE intégré Mode principale de Bus Ultra DMA 33 / 66 / 100 / 133 Prend en charge le mode PIO 0~4,	Contrôleur IDE intégré Mode principale de Bus Ultra DMA 33 / 66 / 100 / 133 Prend en charge le mode PIO 0~4,
SATA	Contrôleur Serial ATA intégré : Taux de transfert jusqu'à 1.5 Go/s. Conforme à la spécification SATA Version 1.0	Contrôleur Serial ATA intégré : Taux de transfert jusqu'à 1.5 Go/s. Conforme à la spécification SATA Version 1.0

	Ver 5.x	Ver 6.x
LAN PHY	Realtek RTL 8201CL 10 / 100 Mb/s négociation automatique Half / Full duplex capability	Realtek RTL 8201CL 10 / 100 Mb/s négociation automatique Half / Full duplex capability
Codec audio	ALC888 Prise en charge de l'audio haute définition Sortie audio à 7.1 voies	ALC861VD Prise en charge de l'audio haute définition Sortie audio à 5.1 voies
Fentes	Fente PCI x2 Slot PCI Express x16 x1 Slot PCI Express x 1 x1	Fente PCI x2 Slot PCI Express x16 x1 Slot PCI Express x 1 x1
Connecteur embarqué	Connecteur de disquette x1 Connecteur IDE x2 Connecteur SATA x2 Connecteur du panneau avant x1 Connecteur Audio du panneau avant x1 Connecteur d'entrée CD x1 Connecteur de sortie S/PDIF x1 Embase de ventilateur UC x1 Embase de ventilateur système x1 Embase d'effacement CMOS x1 Connecteur USB x2 Connecteur d'alimentation x1 (24 broches) Connecteur d'alimentation x1 (4 broches)	Connecteur de disquette x1 Connecteur IDE x2 Connecteur SATA x2 Connecteur du panneau avant x1 Connecteur Audio du panneau avant x1 Connecteur d'entrée CD x1 Connecteur de sortie S/PDIF x1 Embase de ventilateur UC x1 Embase de ventilateur système x1 Embase d'effacement CMOS x1 Connecteur USB x2 Connecteur d'alimentation x1 (24 broches) Connecteur d'alimentation x1 (4 broches)
E/S du panneau arrière	Clavier PS/2 x1 Souris PS/2 x1 Port série x1 Port d'imprimante x1 Port VGA x1 Port LAN x1 Port USB x4 Fiche audio x6	Clavier PS/2 x1 Souris PS/2 x1 Port série x1 Port d'imprimante x1 Port VGA x1 Port LAN x1 Port USB x4 Fiche audio x3
Dimensions de la carte	190 mm (l) X 244 mm (H)	190 mm (l) X 244 mm (H)
Support SE	Windows 2K / XP / VISTA Biostar se réserve le droit d'ajouter ou de supprimer le support de SE avec ou sans préavis.	Windows 2K / XP / VISTA Biostar se réserve le droit d'ajouter ou de supprimer le support de SE avec ou sans préavis.

ITALIAN

	<i>Ver 5.x</i>	<i>Ver 6.x</i>
CPU	LGA 775 Processore Intel Core2Duo/ Pentium 4 / Pentium D / Celeron D fino a 3.8 GHz Supporto di Hyper-Threading / Execute Disable Bit / Enhanced Intel SpeedStep® / Architettura Intel 64 / Tecnologia Extended Memory 64 *It is recommended to use processors with 95W power consumption.	LGA 775 Processore Intel Core2Duo/ Pentium 4 / Pentium D / Celeron D fino a 3.8 GHz Supporto di Hyper-Threading / Execute Disable Bit / Enhanced Intel SpeedStep® / Architettura Intel 64 / Tecnologia Extended Memory 64 *It is recommended to use processors with 95W power consumption.
FSB	533 / 800 / 1066 MHz	533 / 800 / 1066 MHz
Chipset	VIA P4M900 VIA VT8237A	VIA P4M900 VIA VT8237A
Grafica	Chrome9 HC 3D / 2D Graphics La memoria video condivisa massima è di 256MB	Chrome9 HC 3D / 2D Graphics La memoria video condivisa massima è di 256MB
Super I/O	ITE 8712F Fornisce le funzionalità legacy Super I/O usate più comunemente. Interfaccia LPC (Low Pin Count) Funzioni di controllo dell'ambiente: Monitoraggio hardware Controller velocità ventolina Funzione "Smart Guardian" di ITE	ITE 8712F Fornisce le funzionalità legacy Super I/O usate più comunemente. Interfaccia LPC (Low Pin Count) Funzioni di controllo dell'ambiente: Monitoraggio hardware Controller velocità ventolina Funzione "Smart Guardian" di ITE
Memoria principale	Alloggi DIMM DDR2 x 2 Supporto di DDR2 533 / 667 Ciascun DIMM supporta DDR2 256MB / 512MB / 1GB / 2GB Capacità massima della memoria 4GB Modulo di memoria DDR2 a canale singolo DIMM registrati e DIMM ECC non sono supportati	Alloggi DIMM DDR2 x 2 Supporto di DDR2 533 / 667 Ciascun DIMM supporta DDR2 256MB / 512MB / 1GB / 2GB Capacità massima della memoria 4GB Modulo di memoria DDR2 a canale singolo DIMM registrati e DIMM ECC non sono supportati
IDE	Controller IDE integrato Modalità Bus Master Ultra DMA 33 / 66 / 100 / 133 Supporto modalità PIO Mode 0-4	Controller IDE integrato Modalità Bus Master Ultra DMA 33 / 66 / 100 / 133 Supporto modalità PIO Mode 0-4
SATA	Controller Serial ATA integrato Velocità di trasferimento dei dati fino a 1.5 Gb/s. Compatibile specifiche SATA Versione 1.0.	Controller Serial ATA integrato Velocità di trasferimento dei dati fino a 1.5 Gb/s. Compatibile specifiche SATA Versione 1.0.

	Ver 5.x	Ver 6.x
LAN PHY	Realtek RTL 8201CL Negoziazione automatica 10 / 100 Mb/s Capacità Half / Full Duplex	Realtek RTL 8201CL Negoziazione automatica 10 / 100 Mb/s Capacità Half / Full Duplex
Codec audio	ALC888 Supporto audio High-Definition (HD) Uscita audio 7.1 canali	ALC861VD Supporto audio High-Definition (HD) Uscita audio 5.1 canali
Alloggi	Alloggio PCI x2 Alloggio PCI Express x16 x1 Alloggio PCI Express x1 x1	Alloggio PCI x2 Alloggio PCI Express x16 x1 Alloggio PCI Express x1 x1
Connettori su scheda	Connettore floppy x1 Connettore IDE x2 Connettore SATA x2 Connettore pannello frontale x1 Connettore audio frontale x1 Connettore CD-in x1 Connettore output SPDIF x1 Collettore ventolina CPU x1 Collettore ventolina sistema x1 Collettore cancellazione CMOS x1 Connettore USB x2 Connettore alimentazione (24 pin) x1 Connettore alimentazione (4 pin) x1	Connettore floppy x1 Connettore IDE x2 Connettore SATA x2 Connettore pannello frontale x1 Connettore audio frontale x1 Connettore CD-in x1 Connettore output SPDIF x1 Collettore ventolina CPU x1 Collettore ventolina sistema x1 Collettore cancellazione CMOS x1 Connettore USB x2 Connettore alimentazione (24 pin) x1 Connettore alimentazione (4 pin) x1
I/O pannello posteriore	Tastiera PS/2 x1 Mouse PS/2 x1 Porta seriale x1 Porta stampante x1 Porta VGA x1 Porta LAN x1 Porta USB x4 Connettore audio x6	Tastiera PS/2 x1 Mouse PS/2 x1 Porta seriale x1 Porta stampante x1 Porta VGA x1 Porta LAN x1 Porta USB x4 Connettore audio x3
Dimensioni scheda	190 mm (larghezza) x 244 mm (altezza)	190 mm (larghezza) x 244 mm (altezza)
Sistemi operativi supportati	Windows 2K / XP / VISTA Biostar si riserva il diritto di aggiungere o rimuovere il supporto di qualsiasi sistema operativo senza preavviso.	Windows 2K / XP / VISTA Biostar si riserva il diritto di aggiungere o rimuovere il supporto di qualsiasi sistema operativo senza preavviso.

SPANISH

	<i>Ver 5.x</i>	<i>Ver 6.x</i>
CPU	LGA 775 Procesador Intel Core2Duo/ Pentium 4 / Pentium D / Celeron D hasta 3,8 GHz Admite Hyper-Threading / Bit de deshabilitación de ejecución/ Intel SpeedStep® Mejorado / Intel Architecture-64 / Tecnología Extended Memory 64 *It is recommended to use processors with 95W power consumption.	LGA 775 Procesador Intel Core2Duo/ Pentium 4 / Pentium D / Celeron D hasta 3,8 GHz Admite Hyper-Threading / Bit de deshabilitación de ejecución/ Intel SpeedStep® Mejorado / Intel Architecture-64 / Tecnología Extended Memory 64 *It is recommended to use processors with 95W power consumption.
FSB	533 / 800 / 1066 MHz	533 / 800 / 1066 MHz
Conjunto de chips	VIA P4M900 VIA VT8237A	VIA P4M900 VIA VT8237A
Gráficos	Chrome9 HC 3D / 2D Graphics Memoria máxima de vídeo compartida de 256MB	Chrome9 HC 3D / 2D Graphics Memoria máxima de vídeo compartida de 256MB
Súper E/S	ITE 8712F Le ofrece las funcionalidades heredadas de uso más común Súper E/S. Interfaz de cuenta Low Pin Iniciativas de control de entorno, Monitor hardware Controlador de velocidad de ventilador Función "Guardia inteligente" de ITE	ITE 8712F Le ofrece las funcionalidades heredadas de uso más común Súper E/S. Interfaz de cuenta Low Pin Iniciativas de control de entorno, Monitor hardware Controlador de velocidad de ventilador Función "Guardia inteligente" de ITE
Memoria principal	Ranuras DIMM DDR 2 x 2 Admite DDR2 de 533 / 667 Cada DIMM admite DDR de 256MB / 512MB / 1GB / 2GB Capacidad máxima de memoria de 4GB Módulo de memoria DDR 2 de canal Sencillo No admite DIMM registrados o DIMM compatibles con ECC	Ranuras DIMM DDR 2 x 2 Admite DDR2 de 533 / 667 Cada DIMM admite DDR de 256MB / 512MB / 1GB / 2GB Capacidad máxima de memoria de 4GB Módulo de memoria DDR 2 de canal Sencillo No admite DIMM registrados o DIMM compatibles con ECC
IDE	Controlador IDE integrado Modo bus maestro Ultra DMA 33 / 66 / 100 / 133 Soporte los Modos PIO 0~4,	Controlador IDE integrado Modo bus maestro Ultra DMA 33 / 66 / 100 / 133 Soporte los Modos PIO 0~4,
SATA	Controlador ATA Serie Integrado Tasas de transferencia de hasta 1.5 Gb/s. Compatible con la versión SATA 1.0.	Controlador ATA Serie Integrado Tasas de transferencia de hasta 1.5 Gb/s. Compatible con la versión SATA 1.0.

	Ver 5.x	Ver 6.x
Red Local	Realtek RTL 8201CL Negociación de 10 / 100 Mb/s Funciones Half / Full dúplex	Realtek RTL 8201CL Negociación de 10 / 100 Mb/s Funciones Half / Full dúplex
Códecs de sonido	ALC888 Soporte de sonido de Alta Definición Salida de sonido de 7.1 canales	ALC861VD Soporte de sonido de Alta Definición Salida de sonido de 5.1 canales
Ranuras	Ranura PCI X2 Ranura PCI Express x16 X1 Ranura PCI express x 1 X1	Ranura PCI X2 Ranura PCI Express x16 X1 Ranura PCI express x 1 X1
Conectores en placa	Conector disco flexible X1 Conector IDE X2 Conector SATA X2 Conector de panel frontal X1 Conector de sonido frontal X1 Conector de entrada de CD X1 Conector de salida S/PDIF X1 Cabecera de ventilador de CPU X1 Cabecera de ventilador de sistema X1 Cabecera de borrado de CMOS X1 Conector USB X2 Conector de alimentación (24 patillas) X1 Conector de alimentación (4 patillas) X1	Conector disco flexible X1 Conector IDE X2 Conector SATA X2 Conector de panel frontal X1 Conector de sonido frontal X1 Conector de entrada de CD X1 Conector de salida S/PDIF X1 Cabecera de ventilador de CPU X1 Cabecera de ventilador de sistema X1 Cabecera de borrado de CMOS X1 Conector USB X2 Conector de alimentación (24 patillas) X1 Conector de alimentación (4 patillas) X1
Panel trasero de E/S	Teclado PS/2 X1 Ratón PS/2 X1 Puerto serie X1 Puerto de impresora X1 Puerto VGA X1 Puerto de red local X1 Puerto USB X4 Conector de sonido X6	Teclado PS/2 X1 Ratón PS/2 X1 Puerto serie X1 Puerto de impresora X1 Puerto VGA X1 Puerto de red local X1 Puerto USB X4 Conector de sonido X3
Tamaño de la placa	190mm. (A) X 244 Mm. (H)	190mm. (A) X 244 Mm. (H)
Soporte de sistema operativo	Windows 2K / XP / VISTA Biostar se reserva el derecho de añadir o retirar el soporte de cualquier SO con o sin aviso previo.	Windows 2K / XP / VISTA Biostar se reserva el derecho de añadir o retirar el soporte de cualquier SO con o sin aviso previo.

PORTUGUESE

	<i>Ver 5.x</i>	<i>Ver 6.x</i>
CPU	LGA 775 Processador Intel Core2Duo/ Pentium 4 / Pentium D / Celeron D até 3,8 GHz Suporta as tecnologias Hyper-Threading / Execute Disable Bit / Enhanced Intel SpeedStep® / Intel Architecture -64 / Extended Memory 64 *It is recommended to use processors with 95W power consumption.	LGA 775 Processador Intel Core2Duo/ Pentium 4 / Pentium D / Celeron D até 3,8 GHz Suporta as tecnologias Hyper-Threading / Execute Disable Bit / Enhanced Intel SpeedStep® / Intel Architecture -64 / Extended Memory 64 *It is recommended to use processors with 95W power consumption.
FSB	533 / 800 / 1066 MHz	533 / 800 / 1066 MHz
Chipset	VIA P4M900 VIA VT8237A	VIA P4M900 VIA VT8237A
Placa gráfica	Chrome9 HC 3D / 2D Graphics Memória de vídeo máxima partilhada: 256 MB	Chrome9 HC 3D / 2D Graphics Memória de vídeo máxima partilhada: 256 MB
Especificação Super I/O	ITE 8712F Proporciona as funcionalidades mais utilizadas em termos da especificação Super I/O. Interface LPC (Low Pin Count). Iniciativas para controlo do ambiente Monitorização do hardware Controlador da velocidade da ventoinha Função "Smart Guardian" da ITE	ITE 8712F Proporciona as funcionalidades mais utilizadas em termos da especificação Super I/O. Interface LPC (Low Pin Count). Iniciativas para controlo do ambiente Monitorização do hardware Controlador da velocidade da ventoinha Função "Smart Guardian" da ITE
Memória principal	Ranuras DIMM DDR2 x 2 Suporta módulos DDR2 533 / 667 Cada módulo DIMM suporta uma memória DDR2 de 256MB / 512 MB / 1 GB / 2GB Capacidade máxima de memória: 4 GB Módulo de memória DDR2 de canal simples Os módulos DIMM registados e os DIMM ECC não são suportados	Ranuras DIMM DDR2 x 2 Suporta módulos DDR2 533 / 667 Cada módulo DIMM suporta uma memória DDR2 de 256MB / 512 MB / 1 GB / 2GB Capacidade máxima de memória: 4 GB Módulo de memória DDR2 de canal simples Os módulos DIMM registados e os DIMM ECC não são suportados
IDE	Controlador IDE integrado Modo Bus master Ultra DMA 33 / 66 / 100 / 133 Suporta o modo PIO 0~4,	Controlador IDE integrado Modo Bus master Ultra DMA 33 / 66 / 100 / 133 Suporta o modo PIO 0~4,
SATA	Controlador Serial ATA integrado Velocidades de transmissão de dados até 1.5 Gb/s. Compatibilidade com a especificação SATA versão 1.0.	Controlador Serial ATA integrado Velocidades de transmissão de dados até 1.5 Gb/s. Compatibilidade com a especificação SATA versão 1.0.

	Ver 5.x	Ver 6.x
LAN PHY	Realtek RTL 8201CL Auto negociação de 10 / 100 MB/s Capacidade semi/full-duplex	Realtek RTL 8201CL Auto negociação de 10 / 100 MB/s Capacidade semi/full-duplex
Codec de som	ALC888 Suporta a especificação High-Definition Audio Saída de áudio de 7.1 canais	ALC861VD Suporta a especificação High-Definition Audio Saída de áudio de 5.1 canais
Ranhuras	Ranhura PCI x2 Ranhura PCI Express x16 x1 Ranhura PCI Express x 1 x1	Ranhura PCI x2 Ranhura PCI Express x16 x1 Ranhura PCI Express x 1 x1
Conectores na placa	Conector da unidade de disquetes x1 Conector IDE x2 Conector SATA x2 Conector do painel frontal x1 Conector de áudio frontal x1 Conector para entrada de CDs x1 Conector de saída S/PDIF x1 Conector da ventoinha da CPU x1 Conector da ventoinha do sistema x1 Conector para limpeza do CMOS x1 Conector USB x2 Conector de alimentação (24 pinos) x1 Conector de alimentação (4 pinos) x1	Conector da unidade de disquetes x1 Conector IDE x2 Conector SATA x2 Conector do painel frontal x1 Conector de áudio frontal x1 Conector para entrada de CDs x1 Conector de saída S/PDIF x1 Conector da ventoinha da CPU x1 Conector da ventoinha do sistema x1 Conector para limpeza do CMOS x1 Conector USB x2 Conector de alimentação (24 pinos) x1 Conector de alimentação (4 pinos) x1
Entradas/Saídas no painel traseiro	Teclado PS/2 x1 Rato PS/2 x1 Porta série x1 Porta para impressora x1 Porta VGA x1 Porta LAN x1 Porta USB x4 Tomada de áudio x6	Teclado PS/2 x1 Rato PS/2 x1 Porta série x1 Porta para impressora x1 Porta VGA x1 Porta LAN x1 Porta USB x4 Tomada de áudio x3
Tamanho da placa	190 mm (L) X 244 mm (A)	190 mm (L) X 244 mm (A)
Sistemas operativos suportados	Windows 2K / XP / VISTA A Biostar reserva-se o direito de adicionar ou remover suporte para qualquer sistema operativo com ou sem aviso prévio.	Windows 2K / XP / VISTA A Biostar reserva-se o direito de adicionar ou remover suporte para qualquer sistema operativo com ou sem aviso prévio.

POLISH

	<i>Ver 5.x</i>	<i>Ver 6.x</i>
Procesor	LGA 775 Procesor Intel Core2Duo/ Pentium 4 / Pentium D / Celeron D do 3,8 GHz Obsługa Hyper-Threading / Execute Disable Bit / Enhanced Intel SpeedStep® / Intel Architecture-64 / Extended Memory 64 Technology *It is recommended to use processors with 95W power consumption.	LGA 775 Procesor Intel Core2Duo/ Pentium 4 / Pentium D / Celeron D do 3,8 GHz Obsługa Hyper-Threading / Execute Disable Bit / Enhanced Intel SpeedStep® / Intel Architecture-64 / Extended Memory 64 Technology *It is recommended to use processors with 95W power consumption.
FSB	533 / 800 / 1066 MHz	533 / 800 / 1066 MHz
Chipset	VIA P4M900 VIA VT8237A	VIA P4M900 VIA VT8237A
Grafika	Chrome9 HC 3D / 2D Graphics Maks. wielkość współdzielonej pamięci video wynosi 256MB	Chrome9 HC 3D / 2D Graphics Maks. wielkość współdzielonej pamięci video wynosi 256MB
Pamięć główna	Gniazda DDR 2 DIMM x 2 Obsługa DDR2 533 / 667 Każde gniazdo DIMM obsługuje moduły 256MB / 512MB / 1GB / 2GB DDR2 Maks. wielkość pamięci 4GB Moduł pamięci DDR2 z trybem pojedynczego kanału Brak obsługi Registered DIMM oraz ECC DIMM	Gniazda DDR 2 DIMM x 2 Obsługa DDR2 533 / 667 Każde gniazdo DIMM obsługuje moduły 256MB / 512MB / 1GB / 2GB DDR2 Maks. wielkość pamięci 4GB Moduł pamięci DDR2 z trybem pojedynczego kanału Brak obsługi Registered DIMM oraz ECC DIMM
Super I/O	ITE 8712F Zapewnia najbardziej powszechne funkcje Super I/O. Interfejs Low Pin Count Funkcje kontroli warunków pracy, Monitor H/W Kontroler prędkości wentylatora Funkcja ITE "Smart Guardian"	ITE 8712F Zapewnia najbardziej powszechne funkcje Super I/O. Interfejs Low Pin Count Funkcje kontroli warunków pracy, Monitor H/W Kontroler prędkości wentylatora Funkcja ITE "Smart Guardian"
IDE	Zintegrowany kontroler IDE Ultra DMA 33 / 66 / 100 / 133 Tryb Bus Master obsługa PIO tryb 0~4,	Zintegrowany kontroler IDE Ultra DMA 33 / 66 / 100 / 133 Tryb Bus Master obsługa PIO tryb 0~4,
SATA	Zintegrowany kontroler Serial ATA Transfer danych do 1.5 Gb/s. Zgodność ze specyfikacją SATA w wersji 1.0.	Zintegrowany kontroler Serial ATA Transfer danych do 1.5 Gb/s. Zgodność ze specyfikacją SATA w wersji 1.0.

	Ver 5.x	Ver 6.x
LAN PHY	Realtek RTL 8201CL 10 / 100 Mb/s z automatyczną negocjacją szybkości Działanie w trybie połowicznego / pełnego dupleksu	Realtek RTL 8201CL 10 / 100 Mb/s z automatyczną negocjacją szybkości Działanie w trybie połowicznego / pełnego dupleksu
Kodek dźwiękowy	ALC888 Obsługa Hi gh- Definitio n Audio 7.1 kanałowe wyjście audio	ALC861VD Obsługa Hi gh- Definitio n Audio 5.1 kanałowe wyjście audio
Gniazda	Gniazdo PCI x2 Gniazdo PCI Express x16 x1 Gniazdo PCI Express x 1 x1	Gniazdo PCI x2 Gniazdo PCI Express x16 x1 Gniazdo PCI Express x 1 x1
Złącza wbudowan e	Złącze napędu dyskietek x1 Złącze IDE x2 Złącze SATA x2 Złącze panela przedniego x1 Przednie złącze audio x1 Złącze wejścia CD x1 Złącze wyjścia S/PDIF x1 Złącze główkowe wentylatora procesora x1 Złącze główkowe wentylatora systemowego x1 Złącze główkowe kasowani a CMOS x1 Złącze USB x2 Złącze zasilania (24 pinowe) x1 Złącze zasilania (4 pinowe) x1	Złącze napędu dyskietek x1 Złącze IDE x2 Złącze SATA x2 Złącze panela przedniego x1 Przednie złącze audio x1 Złącze wejścia CD x1 Złącze wyjścia S/PDIF x1 Złącze główkowe wentylatora procesora x1 Złącze główkowe wentylatora systemowego x1 Złącze główkowe kasowani a CMOS x1 Złącze USB x2 Złącze zasilania (24 pinowe) x1 Złącze zasilania (4 pinowe) x1
Back Panel I/O	Klawiatura PS/2 x1 Mysz PS/2 x1 Port szeregowy x1 Port drukarki x1 Port VGA x1 Port LAN x1 Port USB x4 Gniazdo audio x6	Klawiatura PS/2 x1 Mysz PS/2 x1 Port szeregowy x1 Port drukarki x1 Port VGA x1 Port LAN x1 Port USB x4 Gniazdo audio x3
Wymiary płyty	190 mm (S) X 244 mm (W)	190 mm (S) X 244 mm (W)
Obsługa systemu operacyjn ego	Windows 2K / XP / VISTA Biostar zastrzega sobie prawo do dawania lub odwoływania obsługi dowolnego systemu operacyjnego bez powiadomienia.	Windows 2K / XP / VISTA Biostar zastrzega sobie prawo do dawania lub odwoływania obsługi dowolnego systemu operacyjnego bez powiadomienia.

RUSSIAN

	Ver 5.x	Ver 6.x
CPU (центральный процессор)	LGA 775 Процессор Intel Core2Duo/ Pentium 4 / Pentium D / Celeron D до 3.8 ГГц Поддержка технологий Hyper-Threading / Execute Disable Bit / Enhanced Intel SpeedStep® / Intel Architecture-64 / Extended Memory 64 Technology *It is recommended to use processors with 95W power consumption.	LGA 775 Процессор Intel Core2Duo/ Pentium 4 / Pentium D / Celeron D до 3.8 ГГц Поддержка технологий Hyper-Threading / Execute Disable Bit / Enhanced Intel SpeedStep® / Intel Architecture-64 / Extended Memory 64 Technology *It is recommended to use processors with 95W power consumption.
FSB	533 / 800 / 1066 МГц	533 / 800 / 1066 МГц
Набор микросхем	VIA P4M900 VIA VT8237A	VIA P4M900 VIA VT8237A
Графика	Chrome9 HC 3D / 2D Graphics Максимальная совместно используемая видео память составляет 256 МБ	Chrome9 HC 3D / 2D Graphics Максимальная совместно используемая видео память составляет 256 МБ
Основная память	Слоты DDR2 DIMM x 2 Поддержка DDR2 533 / 667 Каждый модуль DIMM поддерживает 256МБ / 512МБ / 1ГБ / 2ГБ DDR2 Максимальная ёмкость памяти 4 ГБ Модуль памяти с одноканальным режимом DDR2 Не поддерживает зарегистрированные модули DIMM and ECC DIMM	Слоты DDR2 DIMM x 2 Поддержка DDR2 533 / 667 Каждый модуль DIMM поддерживает 256МБ / 512МБ / 1ГБ / 2ГБ DDR2 Максимальная ёмкость памяти 4 ГБ Модуль памяти с одноканальным режимом DDR2 Не поддерживает зарегистрированные модули DIMM and ECC DIMM
Super I/O	ITE 8712F Обеспечивает наиболее используемые действующие функциональные возможности Super I/O. Интерфейс с низким количеством выводов Инициативы по охране окружающей среды, Аппаратный монитор Регулятор скорости Функция ITE "Smart Guardian" (Интеллектуальная защита)	ITE 8712F Обеспечивает наиболее используемые действующие функциональные возможности Super I/O. Интерфейс с низким количеством выводов Инициативы по охране окружающей среды, Аппаратный монитор Регулятор скорости Функция ITE "Smart Guardian" (Интеллектуальная защита)
IDE	Встроенное устройство управления встроенными интерфейсами устройств Режим "хозяина" шины Ultra DMA 33 / 66 / 100 / 133 Поддержка режима PIO 0~4,	Встроенное устройство управления встроенными интерфейсами устройств Режим "хозяина" шины Ultra DMA 33 / 66 / 100 / 133 Поддержка режима PIO 0~4,
SATA	Встроенное последовательное устройство управления ATA скорость передачи данных до 1.5 гигабит/с. Соответствие спецификации SATA версия 1.0.	Встроенное последовательное устройство управления ATA скорость передачи данных до 1.5 гигабит/с. Соответствие спецификации SATA версия 1.0.

	Ver 5.x	Ver 6.x
Локальная сеть	Realtek RTL 8201CL Автоматическое согласование 10 / 100 Мб/с Частичная / полная дуплексная способность	Realtek RTL 8201CL Автоматическое согласование 10 / 100 Мб/с Частичная / полная дуплексная способность
Звуковой кодек	ALC888 Звуковая поддержка High-Definition 7.1канальный звуковой выход	ALC861VD Звуковая поддержка High-Definition 5.1канальный звуковой выход
Слоты	Слот PCI x2 Слот PCI Express x16 x1 Слот PCI Express x1 x1	Слот PCI x2 Слот PCI Express x16 x1 Слот PCI Express x1 x1
Встроенный разъём	Разъём HГМД x1 Разъём IDE x2 Разъём SATA x2 Разъём на лицевой панели x1 Входной звуковой разъём x1 Разъём ввода для CD x1 Разъём вывода для S/PDIF x1 Контактирующее приспособление вентилятора центрального процессора x1 Контактирующее приспособление вентилятора системы x1 Открытое контактирующее приспособление CMOS x1 USB-разъём x2 Разъём питания (24 вывод) x1 Разъём питания (4 вывод) x1	Разъём HГМД x1 Разъём IDE x2 Разъём SATA x2 Разъём на лицевой панели x1 Входной звуковой разъём x1 Разъём ввода для CD x1 Разъём вывода для S/PDIF x1 Контактирующее приспособление вентилятора центрального процессора x1 Контактирующее приспособление вентилятора системы x1 Открытое контактирующее приспособление CMOS x1 USB-разъём x2 Разъём питания (24 вывод) x1 Разъём питания (4 вывод) x1
Задняя панель средств ввода-вывода	Клавиатура PS/2 x1 Мышь PS/2 x1 Последовательный порт x1 Порт подключения принтера x1 Порт VGA x1 Порт LAN x1 USB-порт x4 Гнездо для подключения наушников x6	Клавиатура PS/2 x1 Мышь PS/2 x1 Последовательный порт x1 Порт подключения принтера x1 Порт VGA x1 Порт LAN x1 USB-порт x4 Гнездо для подключения наушников x3
Размер панели	190 мм (Ш) X 244 мм (В)	190 мм (Ш) X 244 мм (В)
Поддержка OS	Windows 2K / XP / VISTA Biostar сохраняет за собой право добавлять или удалять средства обеспечения для OS с или без предварительного уведомления.	Windows 2K / XP / VISTA Biostar сохраняет за собой право добавлять или удалять средства обеспечения для OS с или без предварительного уведомления.

ARABIC

Ver 6.x	Ver 5.x	
LGA 775 Intel Core2Duo/ Pentium 4 / Pentium D / Celeron D يتردد يصل إلى 3.8 جيجا هرتز Hyper-Threading / Execute Disable Bit / Enhanced Intel SpeedStep® / Extended Memory 64 Technology *It is recommended to use processors with 95W power consumption.	LGA 775 Intel Core2Duo/ Pentium 4 / Pentium D / Celeron D يتردد يصل إلى 3.8 جيجا هرتز Hyper-Threading / Execute Disable Bit / Enhanced Intel SpeedStep® / Extended Memory 64 Technology *It is recommended to use processors with 95W power consumption.	وحدة المعالجة المركزية
ميغا هرتز 533 / 800 / 1066 تردد	ميغا هرتز 533 / 800 / 1066 تردد	الناقل الأمامي الجانبي
VIA P4M900 VIA VT8237A	VIA P4M900 VIA VT8237A	مجموعة الشرائح
Chrome9 HC 3D / 2D Graphics ميغا بايت 256 أقصى سعة لذاكرة الفيديو المشتركة	Chrome9 HC 3D / 2D Graphics ميغا بايت 256 أقصى سعة لذاكرة الفيديو المشتركة	بطاقة الرسوميات
عدد 4 فتحة DDR2 DIMM ميغا بايت 667 / 533 سعرات DDR2 تدعم الذاكرة من نوع سعة DDR2 تدعم ذاكرة من نوع DIMM كل فتحة ميغا بايت 1 و 2 جيجا بايت / 512 ميغا بايت 256 بايت سعة ذاكرة قصوى 4 جيجا بايت أحادية القناة DDR2 وحدة ذاكرة المسجلة وتلك التي لا تتوافق مع DIMM لا تدعم رقائق الذاكرة ECC	عدد 4 فتحة DDR2 DIMM ميغا بايت 667 / 533 سعرات DDR2 تدعم الذاكرة من نوع سعة DDR2 تدعم ذاكرة من نوع DIMM كل فتحة ميغا بايت 1 و 2 جيجا بايت / 512 ميغا بايت 256 بايت سعة ذاكرة قصوى 4 جيجا بايت أحادية القناة DDR2 وحدة ذاكرة المسجلة وتلك التي لا تتوافق مع DIMM لا تدعم رقائق الذاكرة ECC	الذاكرة الرئيسية
ITE 8712F الأكثر استخداماً. Super I/O يوفر وظيفة Low Pin Count Interface تدعم تقنية وسائل التحكم في البيئة: مراقب لمعرفة حالة الأجهزة مراقب في سرعة المروحة ITE من "Smart Guardian" وظيفة	ITE 8712F الأكثر استخداماً. Super I/O يوفر وظيفة Low Pin Count Interface تدعم تقنية وسائل التحكم في البيئة: مراقب لمعرفة حالة الأجهزة مراقب في سرعة المروحة ITE من "Smart Guardian" وظيفة	Super I/O
متكامل IDE متحكم Ultra DMA 33 / 66 / 100 / 133 ناقل بتقنية وضع رئيسي PIO Mode 0~4 دعم وضع	متكامل IDE متحكم Ultra DMA 33 / 66 / 100 / 133 ناقل بتقنية وضع رئيسي PIO Mode 0~4 دعم وضع	منفذ IDE
متكامل Serial ATA متحكم نقل البيانات بسرعات تصل إلى 1.5 جيجابايت/ثانية. 1.0 الإصدار SATA مطابقة لمواصفات	متكامل Serial ATA متحكم نقل البيانات بسرعات تصل إلى 1.5 جيجابايت/ثانية. 1.0 الإصدار SATA مطابقة لمواصفات	SATA

P4M900 Micro 775

Ver 6.x	Ver 5.x	
Realtek RTL 8201CL تفاوض تلقائي 100/10 ميجا بايت / ثلثية إمكانية النقل المزدوج الكامل/النصفي	Realtek RTL 8201CL تفاوض تلقائي 100/10 ميجا بايت / ثلثية إمكانية النقل المزدوج الكامل/النصفي	شبكة داخلية
ALC861VD تدعم تقنية الصوت عالي التعريف من 5.1 قنوات لخرج الصوت	ALC888 تدعم تقنية الصوت عالي التعريف من 7.1 قنوات لخرج الصوت	كوديك الصوت
عدد 2 فتحة PCI عدد 1 فتحة PCI Express x 16 عدد 1 فتحة PCI Express x 1	عدد 2 فتحة PCI عدد 1 فتحة PCI Express x 16 عدد 1 فتحة PCI Express x 1	الفتحات
عدد 1 مقدمحرك أقراص مرنة عدد 2 مقمذ IDE عدد 2 مقمذ SATA عدد 1 مقمذ اللوحة الأملية عدد 1 مقمذ الصوت الأملي عدد 1 مقمذ CD-IN عدد 1 مقمذ خرج S/PDIF عدد 1 وصلة مروحة وحدة المعالجة المركزية عدد 1 وصلة مروحة للظلم عدد 1 وصلة مسح CMOS عدد 2 مقمذ USB عدد 1 مقمذ توصيل الطاقة (24دوس) عدد 1 مقمذ توصيل الطاقة (4ديليس)	عدد 1 مقدمحرك أقراص مرنة عدد 2 مقمذ IDE عدد 2 مقمذ SATA عدد 1 مقمذ اللوحة الأملية عدد 1 مقمذ الصوت الأملي عدد 1 مقمذ CD-IN عدد 1 مقمذ خرج S/PDIF عدد 1 وصلة مروحة وحدة المعالجة المركزية عدد 1 وصلة مروحة للظلم عدد 1 وصلة مسح CMOS عدد 2 مقمذ USB عدد 1 مقمذ توصيل الطاقة (24دوس) عدد 1 مقمذ توصيل الطاقة (4ديليس)	المنافذ على سطح اللوحة
عدد 1 لوحة مفاتيح PS/2 عدد 1 مؤس PS/2 عدد 1 مقمذ تسلسلي عدد 1 مقمذ طابعة عدد 1 مقمذ VGA عدد 1 مقمذ شبكة لتصل محلية عدد 4 منافذ USB عدد 3 مقيس صوت	عدد 1 لوحة مفاتيح PS/2 عدد 1 مؤس PS/2 عدد 1 مقمذ تسلسلي عدد 1 مقمذ طابعة عدد 1 مقمذ VGA عدد 1 مقمذ شبكة لتصل محلية عدد 4 منافذ USB عدد 6 مقيس صوت	منافذ دخل/خرج اللوحة الخلفية
190 مم (عرض) X 244 مم (ارتفاع)	190 مم (عرض) X 244 مم (ارتفاع)	حجم اللوحة
Windows 2K / XP / VISTA بحقها في اضافة أو ازالة الدعم لأي نظام Biostar تحتفظ تشغيل باخطار أو بدون اخطار .	Windows 2K / XP / VISTA بحقها في اضافة أو ازالة الدعم لأي نظام Biostar تحتفظ تشغيل باخطار أو بدون اخطار .	دعم أنظمة التشغيل

JAPANESE

	Ver 5.x	Ver 6.x
CPU	LGA 775 Intel Core2Duo/ Pentium 4/ Pentium D / Celeron D processor up to 3.8 GHz Hyper-Threading / Execute Disable Bit / Enhanced Intel SpeedStep® / Intel Architecture-64 / Extended Memory 64 Technology をサポートします *It is recommended to use processors with 95W power consumption.	LGA 775 Intel Core2Duo/ Pentium 4/ Pentium D / Celeron D processor up to 3.8 GHz Hyper-Threading / Execute Disable Bit / Enhanced Intel SpeedStep® / Intel Architecture-64 / Extended Memory 64 Technology をサポートします *It is recommended to use processors with 95W power consumption.
FSB	533 / 800 / 1066 MHz	533 / 800 / 1066 MHz
チップセット	VIA P4M900 VIA VT8237A	VIA P4M900 VIA VT8237A
グラフィックス	Chrome9 HC 3D / 2D Graphics 最大の共有ビデオメモリは256MBです	Chrome9 HC 3D / 2D Graphics 最大の共有ビデオメモリは256MBです
メインメモリ	DDR2 DIMMスロット x 2 DDR2 533 / 667をサポート 各DIMMは 256/ 512MB/1GB/2GB DDR2をサ ポート 最大メモリ容量4GB シングル チャンネルモードDDR2メモリモジュ ール 登録済みDIMMとECC DIMMはサポートされま せん	DDR2 DIMMスロット x 2 DDR2 533 / 667をサポート 各DIMMは 256/ 512MB/1GB/2GB DDR2をサ ポート 最大メモリ容量4GB シングル チャンネルモードDDR2メモリモジュ ール 登録済みDIMMとECC DIMMはサポートされま せん
Super I/O	ITE 8712F もっとも一般に使用されるレガシーSuper I/O 機能を採用しています。 低ピンカウントインターフェイス 環境コントロールイニシアチブ、 H/Wモニター ファン速度コントローラ/ モニター ITEの「スマートガーディアン」機能	ITE 8712F もっとも一般に使用されるレガシーSuper I/O 機能を採用しています。 低ピンカウントインターフェイス 環境コントロールイニシアチブ、 H/Wモニター ファン速度コントローラ/ モニター ITEの「スマートガーディアン」機能
IDE	統合IDEコントローラ Ultra DMA 33 / 66 / 100 / 133バスマスタモー ド PIO Mode 0~4のサポート、	統合IDEコントローラ Ultra DMA 33 / 66 / 100 / 133バスマスタモー ド PIO Mode 0~4のサポート、
SATA	統合シリアルATAコントローラ 最高1.5 Gb/秒のデータ転送速度 SATAバージョン1.0仕様に準拠。	統合シリアルATAコントローラ 最高1.5 Gb/秒のデータ転送速度 SATAバージョン1.0仕様に準拠。

P4M900 Micro 775

	Ver 5.x	Ver 6.x
LAN PHY	Realtek RTL 8201CL 10 / 100 Mb/秒のオートネゴシエーション 半/全二重機能	Realtek RTL 8201CL 10 / 100 Mb/秒のオートネゴシエーション 半/全二重機能
サウンド Codec	ALC888 ハイデフィニションオーディオのサポート 7.1 チャンネルオーディオアウト	ALC861VD ハイデフィニションオーディオのサポート 5.1 チャンネルオーディオアウト
スロット	PCIスロット x2 PCI Express x16スロット x1 PCI Express x 1スロット x1	PCIスロット x2 PCI Express x16スロット x1 PCI Express x 1スロット x1
オンボード コネクタ	フロッピーコネクタ x1 IDEコネクタ x2 SATAコネクタ x2 フロントパネルコネクタ x1 フロントオーディオコネクタ x1 CDインコネクタ x1 S/PDIFアウトコネクタ x1 CPUファンヘッダ x1 システムファンヘッダ x1 CMOSクリアヘッダ x1 USBコネクタ x2 電源コネクタ(24ピン) x1 電源コネクタ(4ピン) x1	フロッピーコネクタ x1 IDEコネクタ x2 SATAコネクタ x2 フロントパネルコネクタ x1 フロントオーディオコネクタ x1 CDインコネクタ x1 S/PDIFアウトコネクタ x1 CPUファンヘッダ x1 システムファンヘッダ x1 CMOSクリアヘッダ x1 USBコネクタ x2 電源コネクタ(24ピン) x1 電源コネクタ(4ピン) x1
背面パネル I/O	PS/2キーボード x1 PS/2マウス x1 シリアルポート x1 プリンタポート x1 VGAポート x1 LANポート x1 USBポート x4 オーディオジャック x6	PS/2キーボード x1 PS/2マウス x1 シリアルポート x1 プリンタポート x1 VGAポート x1 LANポート x1 USBポート x4 オーディオジャック x3
ボードサイ ズ	190 mm (幅) X 244 mm (高さ)	190 mm (幅) X 244 mm (高さ)
OSサポー ト	Windows 2K / XP / VISTA Biostarは事前のサポートなしにOSサポートを 追加または削除する権利を留保します。	Windows 2K / XP / VISTA Biostarは事前のサポートなしにOSサポートを 追加または削除する権利を留保します。

2007/02/26

P4M900 Micro 775 BIOS Setup

BIOS Setup	1
1 Main Menu.....	3
2 Standard CMOS Features.....	7
3 Advanced BIOS Features	9
4 Advanced Chipset Features.....	17
5 Integrated Peripherals.....	21
6 Power Management Setup.....	28
7 PnP/PCI Configurations.....	33
8 PC Health Status	36
9 Performance Booster Zone.....	38

P4M900 Micro 775

BIOS Setup

Introduction

The purpose of this manual is to describe the settings in the Award™ BIOS Setup program on this motherboard. The Setup program allows users to modify the basic system configuration and save these settings to CMOS RAM. The power of CMOS RAM is supplied by a battery so that it retains the Setup information when the power is turned off.

Basic Input-Output System (BIOS) determines what a computer can do without accessing programs from a disk. This system controls most of the input and output devices such as keyboard, mouse, serial ports and disk drives. BIOS activates at the first stage of the booting process, loading and executing the operating system. Some additional features, such as virus and password protection or chipset fine-tuning options are also included in BIOS.

The rest of this manual will to guide you through the options and settings in BIOS Setup.

Plug and Play Support

This AWARD BIOS supports the Plug and Play Version 1.0A specification and ESCD (Extended System Configuration Data) write.

EPA Green PC Support

This AWARD BIOS supports Version 1.03 of the EPA Green PC specification.

APM Support

This AWARD BIOS supports Version 1.1&1.2 of the Advanced Power Management (APM) specification. Power management features are implemented via the System Management Interrupt (SMI). Sleep and Suspend power management modes are supported. Power to the hard disk drives and video monitors can also be managed by this AWARD BIOS.

ACPI Support

Award ACPI BIOS support Version 1.0 of Advanced Configuration and Power interface specification (ACPI). It provides ASL code for power management and device configuration capabilities as defined in the ACPI specification, developed by Microsoft, Intel and Toshiba.

P4M900 Micro 775

PCI Bus Support

This AWARD BIOS also supports Version 2.1 of the Intel PCI (Peripheral Component Interconnect) local bus specification.

DRAM Support

DDR SDRAM (Double Data Rate Synchronous DRAM) is supported.

Supported CPUs

This AWARD BIOS supports the Intel CPU.

Using Setup

Use the arrow keys to highlight items in most of the place, press <Enter> to select, use the <PgUp> and <PgDn> keys to change entries, press <F1> for help and press <Esc> to quit. The following table provides more detail about how to navigate in the Setup program by using the keyboard.

Keystroke	Function
Up arrow	Move to previous item
Down arrow	Move to next item
Left arrow	Move to the item on the left (menu bar)
Right arrow	Move to the item on the right (menu bar)
Move Enter	Move to the item you desired
PgUp key	Increase the numeric value or make changes
PgDn key	Decrease the numeric value or make changes
+ Key	Increase the numeric value or make changes
- Key	Decrease the numeric value or make changes
Esc key	Main Menu – Quit and not save changes into CMOS Status Page Setup Menu and Option Page Setup Menu – Exit Current page and return to Main Menu
F1 key	General help on Setup navigation keys
F5 key	Load previous values from CMOS
F7 key	Load the optimized defaults
F10 key	Save all the CMOS changes and exit

P4M900 Micro 775

1 Main Menu

Once you enter Award BIOS™ CMOS Setup Utility, the Main Menu will appear on the screen. The Main Menu allows you to select from several setup functions. Use the arrow keys to select among the items and press <Enter> to accept and enter the sub-menu.

!! WARNING !!

For better system performance, the BIOS firmware is being continuously updated. The BIOS information described in this manual (**Figure 1, 2, 3, 4, 5, 6, 7, 8, 9**) is for your reference only. The actual BIOS information and settings on board may be slightly different from this manual.

■ **Figure 1: Main Menu**

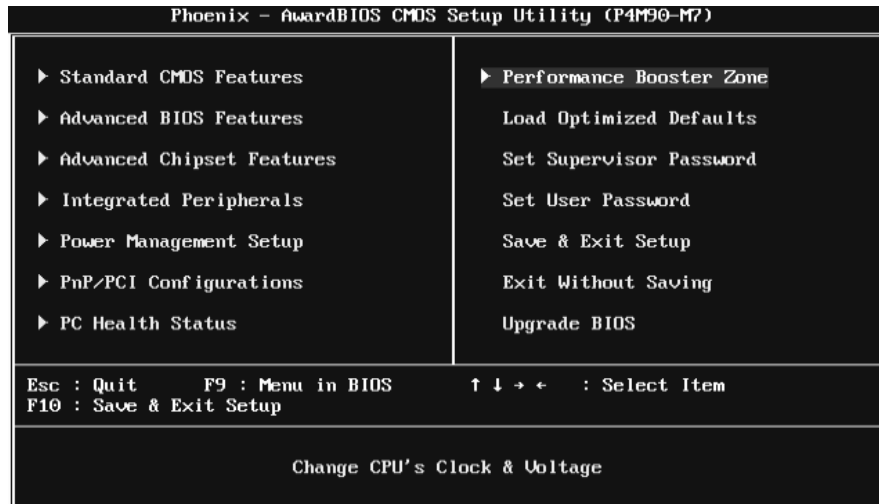

Standard CMOS Features

This submenu contains industry standard configurable options.

Advanced BIOS Features

This submenu allows you to configure advanced features of the BIOS.

P4M900 Micro 775

Advanced Chipset Features

This submenu allows you to configure special chipset features.

Integrated Peripherals

This submenu allows you to configure certain IDE hard drive options and Programmed Input/ Output features.

Power Management Setup

This submenu allows you to configure the power management features.

PnP/PCI Configurations

This submenu allows you to configure certain “Plug and Play” and PCI options.

PC Health Status

This submenu allows you to monitor the hardware of your system.

Performance Booster Zone

This submenu allows you to change CPU Vcore Voltage and CPU/PCI clock. (However, we suggest you to use the default setting. Changing the voltage and clock improperly may damage the CPU or M/B!)

Load Optimized Defaults

This selection allows you to reload the BIOS when problem occurs during system booting sequence. These configurations are factory settings optimized for this system. A confirmation message will be displayed before defaults are set.



P4M900 Micro 775

Set Supervisor Password

Setting the supervisor password will prohibit everyone except the supervisor from making changes using the CMOS Setup Utility. You will be prompted with to enter a password.



```
Enter Password:
```

Set User Password

If the Supervisor Password is not set, then the User Password will function in the same way as the Supervisor Password. If the Supervisor Password is set and the User Password is set, the “User” will only be able to view configurations but will not be able to change them.



```
Enter Password:
```

Save & Exit Setup

Save all configuration changes to CMOS (memory) and exit setup. Confirmation message will be displayed before proceeding.



```
SAVE to CMOS and EXIT (Y/N)? Y
```

Exit Without Saving

Abandon all changes made during the current session and exit setup. Confirmation message will be displayed before proceeding.



```
Quit Without Saving (Y/N)? N
```

P4M900 Micro 775

Upgrade BIOS

This submenu allows you to upgrade bios.

BIOS UPDATE UTILITY (Y/N)? N

P4M900 Micro 775

2 Standard CMOS Features

The items in Standard CMOS Setup Menu are divided into several categories. Each category includes no, one or more than one setup items. Use the arrow keys to highlight the item and then use the <PgUp> or <PgDn> keys to select the value you want in each item.

■ **Figure 2: Standard CMOS Setup**

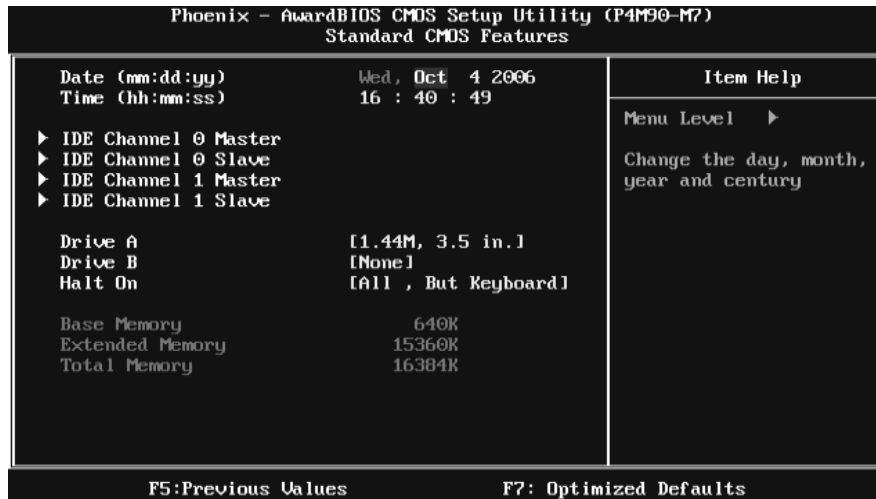

Main Menu Selections

This table shows the items and the available options on the Main Menu.

Item	Options	Description
Date	mm : dd : yy	Set the system date. Note that the 'Day' automatically changes when you set the date.
Time	hh : mm : ss	Set the system internal clock.
IDE Channel 0 Master	Options are in its sub menu.	Press <Enter> to enter the sub menu of detailed options
IDE Channel 0 Slave	Options are in its sub menu.	Press <Enter> to enter the sub menu of detailed options.

P4M900 Micro 775

Item	Options	Description
IDE Channel 1 Master	Options are in its sub menu.	Press <Enter> to enter the sub menu of detailed options.
IDE Channel 1 Slave	Options are in its sub menu.	Press <Enter> to enter the sub menu of detailed options.
Drive A Drive B	360K, 5.25 in 1.2M, 5.25 in 720K, 3.5 in 1.44M, 3.5 in 2.88M, 3.5 in None	Select the type of floppy disk drive installed in your system.
Halt On	All Errors No Errors All, but Key board All, but Diskette All, but Disk/ Key	Select the situation in which you want the BIOS to stop the POST process and notify you.
Base Memory	N/A	Displays the amount of conventional memory detected during boot up.
Extended Memory	N/A	Displays the amount of extended memory detected during boot up.
Total Memory	N/A	Displays the total memory available in the system.

P4M900 Micro 775

3 Advanced BIOS Features

■ Figure 3: Advanced BIOS Setup

Phoenix - AwardBIOS CMOS Setup Utility (P4M90-M7)	
Advanced BIOS Features	
▶ Boot Seq & Floppy Setup [Press Enter]	Item Help
▶ Shadow Setup [Press Enter]	Menu Level ▶
▶ Cache Setup [Press Enter]	
▶ CPU Feature [Press Enter]	
Virus Warning [Disabled]	
Hyper-Threading Technology [Enabled]	
Quick Power On Self Test [Enabled]	
Boot Up NumLock Status [On]	
Typeomatic Rate Setting [Disabled]	
× Typeomatic Rate (Chars/Sec) 6	
× Typeomatic Delay (Msec) 250	
Security Option [Setup]	
MPS Version Control For OS [1.4]	
OS Select For DRAM > 64MB [Non-OS2]	
Small Logo (EPa) Show [Enabled]	
Summary Screen Show [Disabled]	
F5: Previous Values F7: Optimized Defaults	

Boot Seq & Floppy Setup

This item allows you to setup boot sequence & Floppy.

Phoenix - AwardBIOS CMOS Setup Utility (P4M90-M7)	
Boot Seq & Floppy Setup	
▶ Hard Disk Boot Priority [Press Enter]	Item Help
First Boot Device [Floppy]	Menu Level ▶▶
Second Boot Device [Hard Disk]	
Third Boot Device [CDROM]	
Boot Other Device [Enabled]	Select Hard Disk Boot Device Priority
Swap Floppy Drive [Disabled]	
Boot Up Floppy Seek [Enabled]	
F5: Previous Values F7: Optimized Defaults	

P4M900 Micro 775

Hard Disk Boot Priority

The BIOS will attempt to arrange the Hard Disk boot sequence automatically. You can change the Hard Disk booting sequence here.

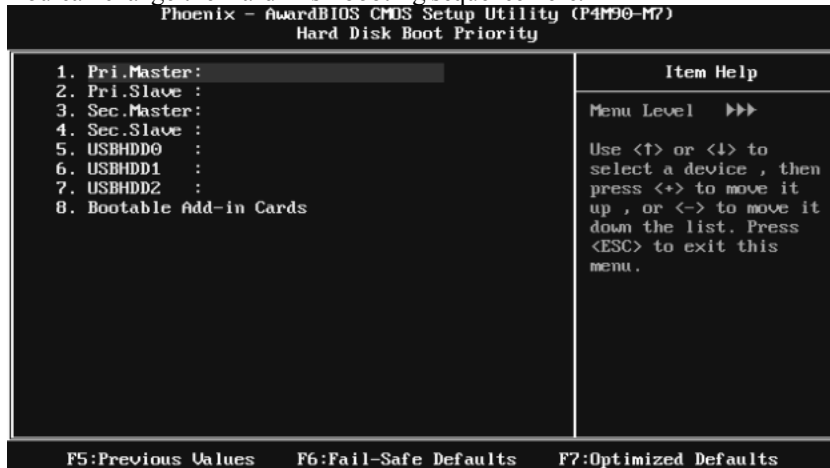

The Choices: Pri. Master, Pri. Slave, Sec. Master, Sec. Slave, USB HDD0, USB HDD1, USB HDD2, and Bootable Add-in Cards.

First/Second/Third Boot Device

The BIOS will attempt to load the operating system in this order.

The Choices: Floppy, LS120, Hard Disk, CDROM, ZIP100, USB-FDD, USB-ZIP, USB-CDROM, LAN, Disabled.

Boot Other Device

When enabled, BIOS will try to load the operating system from other device when it failed to load from the three devices above.

The Choices: Enabled (default), Disabled

Swap Floppy Drive

For systems with two floppy drives, this option allows you to swap logical drive assignments.

The Choices: Disabled (default), Enabled.

P4M900 Micro 775

Boot Up Floppy Seek

When enabled, System will test the floppy drives to determine if they have 40 or 80 tracks during boot up. Disabling this option reduces the time it takes to boot-up.

The Choices: Enabled (default), Disabled.

Shadow Setup

This item allows you to setup cache & shadow setup.

■ **Figure 3.2: Shadow Setup**

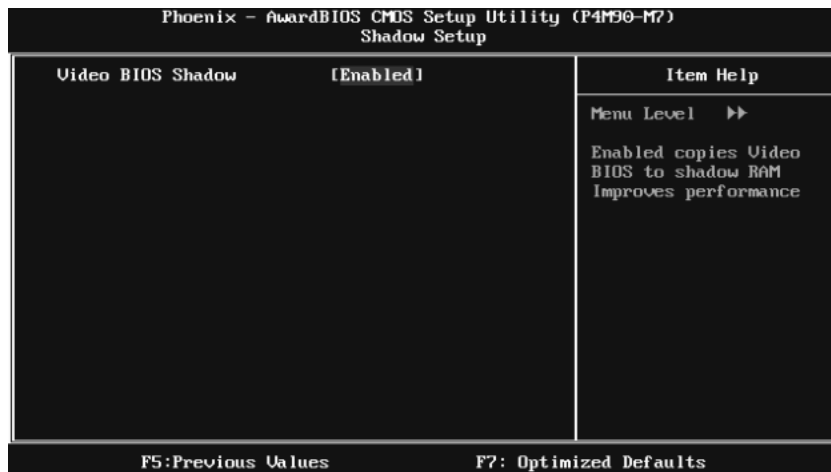

Video BIOS Shadow

Determines whether video BIOS will be copied to RAM for faster execution or not.

Enabled (default) Optional ROM is enabled.

Disabled Optional ROM is disabled.

P4M900 Micro 775

Cache Setup

Phoenix - AwardBIOS CMOS Setup Utility (P4M90-M7)	
Cache Setup	
CPU L1 & L2 Cache	[Enabled]
CPU L3 Cache	[Enabled]
CPU L2 Cache ECC Checking	[Enabled]
	Item Help
	Menu Level >>

F5: Previous Values F7: Optimized Defaults

CPU L1 & L2 Cache

Depending on the CPU/chipset in use, you may be able to increase memory access time with this option.

Enabled (default) Enable cache.

Disabled Disable cache.

CPU L3 Cache

Depending on the CPU/chipset in use, you may be able to increase memory access time with this option.

Enabled (default) Enable cache.

Disabled Disable cache.

CPU L2 Cache ECC Checking

This item allows you to enable/disable CPU L2 Cache ECC Checking.

The Choices: **Enabled** (default), Disabled.

P4M900 Micro 775

CPU Feature

Phoenix - AwardBIOS CMOS Setup Utility (P4M90-M?)		
CPU Feature		
Delay Prior to Thermal	[16 Min]	Item Help
Thermal Management	[Thermal Monitor 1]	Menu Level >>
TM2 Bus Ratio	[0 X]	
TM2 Bus VID	[0.8375V]	
Limit CPUID MaxVal	[Disabled]	
C1E Function	[Auto]	
Execute Disable Bit	[Enabled]	
Virtualization Technology	[Enabled]	

F5: Previous Values F7: Optimized Defaults

Delay Prior to Thermal

Set this item to enable the CPU Thermal function to engage after the specified time.

The Choices: 4 Min, 8 Min, **16Min** (default), 32 Min.

Thermal Management

This option allows you to select the way to control the “Thermal Management.”

The Choices: **Thermal Monitor 1** (default), Thermal Monitor 2.

TM2 Bus Ratio

This option represents the frequency (bus ratio) of the throttled performance state that will be initiated when the on-die sensor detects temperature increase.

Min= 0 Max= 255 Key in a DEC number.

The Choices: **0 X** (default)

TM2 Bus VID

This option represents the voltage of the throttled performance state that will be initiated when the on-die sensor detects temperature increase.

The Choices: **0.8375V** (default), 0.8375-1.6000.

P4M900 Micro 775

Limit CPUID MaxVal

Set Limit CPUID MaxVal to 3, it should be “Disabled” for Windows XP.

The Choices: Disabled (default), Enabled.

C1E Function

This item allows you to configure the Enhanced Halt State (C1E) function, which may reduce the power consumption of your system when the system is idle.

The Choices: Auto (default), Disabled.

Execute Disable Bit

This item allows you to configure the Execute Disabled Bit function, which protects your system from buffer overflow attacks.

The Choices: Enabled (default), Disabled.

Virtualization Technology

Virtualization Technology can virtually separate your system resource into several parts, thus enhance the performance when running virtual machines or multi interface systems.

The Choices: Enabled (default), Disabled.

Virus Warning

This option allows you to choose the VIRUS Warning feature that is used to protect the IDE Hard Disk boot sector. If this function is enabled and an attempt is made to write to the boot sector, BIOS will display a warning message on the screen and sound an alarm beep.

Disabled (default) Virus protection is disabled.

Enabled Virus protection is activated.

Hyper-Threading Technology

This option allows you to enable or disabled Hyper-Threading Technology. “Enabled” for Windows XP and Linux 2.4.x (OS optimized for Hyper-Threading Technology). “Disable” for other OS (OS not optimized for Hyper-Threading Technology).

The Choices: Enabled (default), Disabled.

P4M900 Micro 775

Quick Power On Self Test

Enabling this option will cause an abridged version of the Power On SelfTest (POST) to execute after you power up the computer.

Disabled Normal POST.

Enabled (default) Enable quick POST.

Boot Up NumLock Status

Selects the NumLock State after the system switched on.

The Choices:

On (default) Numpad is number keys.

Off Numpad is arrow keys.

Typematic Rate Setting

When a key is held down, the keystroke will repeat at a rate determined by the keyboard controller. When enabled, the typematic rate and typematic delay can be configured.

The Choices: **Disabled** (default), Enabled.

Typematic Rate (Chars/Sec)

Sets the rate at which a keystroke is repeated when you hold the key down.

The Choices: **6** (default), 8, 10, 12, 15, 20, 24, 30.

Typematic Delay (Msec)

Sets the delay time after the key is held down before it begins to repeat the keystroke.

The Choices: **250** (default), 500, 750, 1000.

Security Option

This option will enable only individuals with passwords to bring the system online and/or to use the CMOS Setup Utility.

System: A password is required for the system to boot and is also required to access the Setup Utility.

Setup (default): A password is required to access the Setup Utility only.

This will only apply if passwords are set from the Setup main menu.

P4M900 Micro 775

MPS Version Control For OS

The BIOS supports version 1.1 and 1.4 of the Intel multiprocessor specification. Select version supported by the operation system running on this computer.

The Choices: 1.4 (default), 1.1.

OS Select For DRAM > 64MB

A choice other than Non-OS2 is only used for OS2 systems with memory exceeding 64MB.

The Choices: Non-OS2 (default), OS2.

Small Logo(EPA) Show

This item allows you to select whether the “Small Logo” shows. Enabled (default) “Small Logo” shows when system boots up. Disabled No “Small Logo” shows when system boots

The Choices: Enabled (default), Disabled

Summary Screen Show

This item allows you to enable/disable the summary screen. Summary screen means system configuration and PCI device listing.

The Choices: Disabled (default), Enabled.

P4M900 Micro 775

4 Advanced Chipset Features

This submenu allows you to configure the specific features of the chipset installed on your system. This chipset manage bus speeds and access to system memory resources, such as DRAM. It also coordinates communications with the PCI bus. The default settings that came with your system have been optimized and therefore should not be changed unless you are suspicious that the settings have been changed incorrectly.

■ **Figure 4: Advanced Chipset Setup**

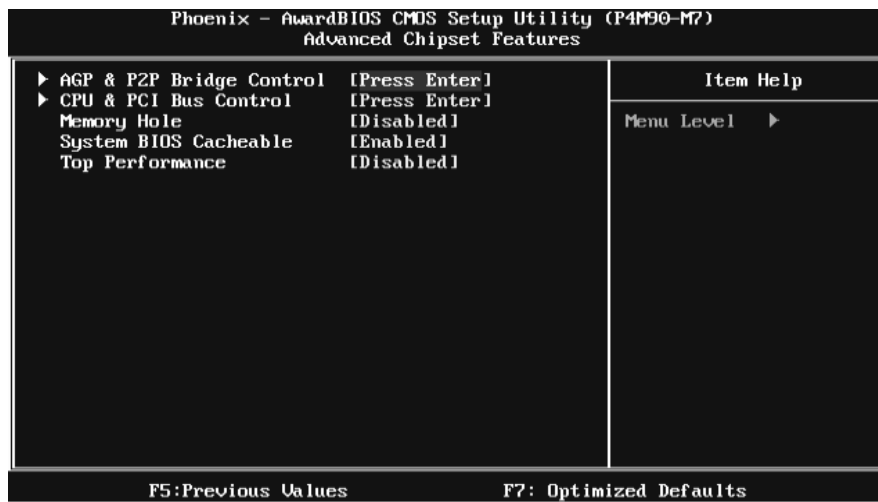

P4M900 Micro 775

AGP & P2P Bridge Control

Highlight “Press Enter” next to the “AGP & P2P Bridge Control” label and pressing the enter key will take you a submenu with the following options:

- **Figure 4.1: AGP & P2P Bridge Control**



VGA Share Memory Size

This item allows you to select the VGA share memory size.

The Choices: 64M (default), 128M, 256M, 512M, Disabled

Direct Frame Buffer

This item allows you to disabled or enabled direct frame buffer

The Choices: Disabled (default), Enabled.

P4M900 Micro 775

CPU & PCI Bus Control

By highlighting the “Press Enter” label next to the “CPU & PCI Bus Control” and press the enter key, it will take you a submenu with the following options:

■ **Figure 4.2: CPU & PCI Bus Control**



PCI Master 0 WS Write

When enabled, writes to the PCI bus are executed with zero-wait states.

The Choices: Enabled (default), Disabled.

PCI Delay Transaction

The chipset has an embedded 32-bit posted write buffer to support delay transactions cycles. Select Enabled to support compliance with PCI specification.

The Choices: Enabled (default), Disabled.

Vlink mode selection

This item allows you to select Vlink mode.

The Choices: By Auto (default), Mode 0, Mode 1, Mode 2, Mode 3, Mode 4.

P4M900 Micro 775

VLink 8X Support

This item allows you to enable or disable VLink 8X support.

The Choices: Enabled (default), Disabled.

VIA PWR Management

The Choices: Enabled (default), Disabled.

Memory Hole

You can reserve this area of system memory for ISA adapter ROM. When this area is reserved it cannot be cached. Check the user information of peripherals that need to use this area of system memory for the memory requirements.

The Choices: Disabled (default), Enabled.

System BIOS Cacheable

Selecting the “Enabled” option allows caching of the system BIOS ROM at F0000h-FFFFFh, which is able to improve the system performance. However, any programs that attempts to write to this memory block will cause conflicts and result in system errors.

The Choices: Enabled (default), Disabled.

Top Performance

The Choices: Disabled (default), Enabled.

P4M900 Micro 775

5 Integrated Peripherals

■ Figure 5. Integrated Peripherals

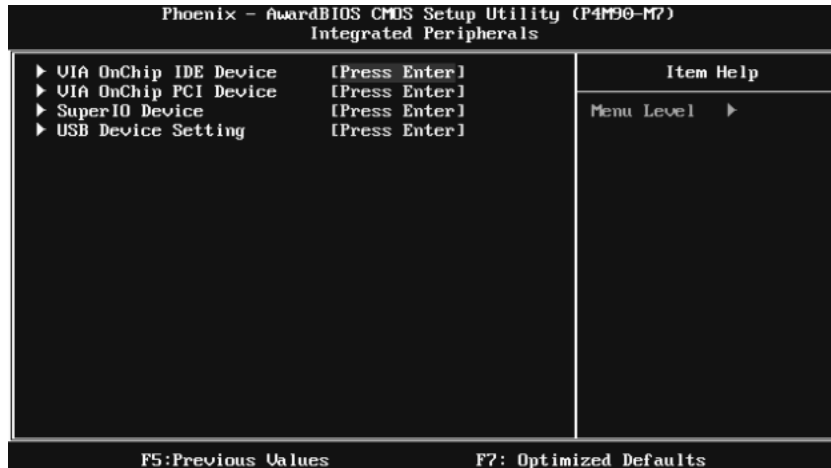

VIA OnChip IDE Device

Highlight the "Press Enter" label next to the "VIA OnChip IDE Device" label and press enter key will take you a submenu with the following options:

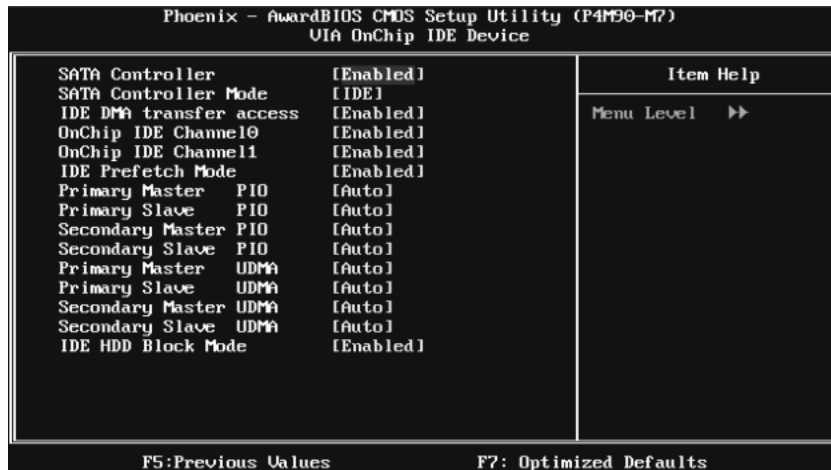

P4M900 Micro 775

SATA Controller

This option allows you to enable the on-chip Serial ATA.

The Choices: Enabled (default), Disabled.

SATA Controller Mode

This option allows you to select SATA Mode.

The Choices: RAID, IDE (default).

IDE DMA Transfer Access

This item allows you to enable or disable the IDE DMA transfer access.

The Choices: Enabled (default), Disabled.

On-chip IDE Channel 0/1

The motherboard chipset contains a PCI IDE interface with support for two IDE channels. Select "Enabled" to activate the first and/or second IDE interface. Select "Disabled" to deactivate an interface if you are going to install a primary and/or secondary add-in IDE interface.

The Choices: Enabled (default), Disabled.

IDE Prefetch Mode

The "onboard" IDE drive interfaces supports IDE prefetch function for faster drive access. If the interface on your drive does not support prefetching, or if you install a primary and/or secondary add-in IDE interface, set this option to "Disabled".

The Choices: Enabled (default), Disabled.

Primary/Secondary/Master/Slave PIO

The IDE PIO (Programmed Input / Output) fields let you set a PIO mode (0-4) for each of the IDE devices that the onboard IDE interface supports. Modes 0 to 4 will increase performance progressively. In Auto mode, the system automatically determines the best mode for each device.

The Choices: Auto (default), Mode0, Mode1, Mode2, Mode3, Mode4.

P4M900 Micro 775

Primary/Secondary/Master/Slave UDMA

Ultra DMA function can be implemented if it is supported by the IDE hard drives in your system. As well, your operating environment requires a DMA driver (Windows 95 or OSR2 may need a third party IDE bus master driver). If your hard drive and your system software both support Ultra DMA, select Auto to enable BIOS support.

The Choices: Auto (default), Disabled.

IDE HDD Block Mode

Block mode is also called block transfer, multiple commands, or multiple sectors read / write. If your IDE hard drive supports block mode (most new drives do), select Enabled for automatic detection of the optimal number of block mode (most new drives do), select Enabled for automatic detection of the optimal number of block read / write per sector where the drive can support.

The Choices: Enabled (default), Disabled.

P4M900 Micro 775

VIA OnChip PCI Device

Highlight the “Press Enter” label next to the “VIA OnChip PCI Device” label and press the enter key will take you a submenu with the following options:

- **Figure 5.2: VIA OnChip PCI Device**



Azalia HDA Controller

This option allows you to control the onboard HD audio.

The Choices: Auto (default), Disabled.

LAN Controller

This option allows you to control the onboard LAN.

The Choices: Enabled (default), Disabled

Lan Boot ROM

Decide whether to invoke the boot ROM of the onboard LAN chip.

The Choices: Disable (default), Enabled.

P4M900 Micro 775

Super IO Device

Press Enter to configure the Super I/O Device.

Phoenix - AwardBIOS CMOS Setup Utility (P4M90-M7)		
SuperIO Device		
Onboard FDC Controller	[Enabled]	Item Help
Onboard Serial Port 1	[3F8/IRQ4]	Menu Level >>
Onboard Parallel Port	[378/IRQ7]	
Parallel Port Mode	[SPP]	
ECP Mode Use DMA	[3]	

F5: Previous Values F7: Optimized Defaults

Onboard FDC Controller

Select enabled if your system has a floppy disk controller (FDC) installed on the system board and you wish to use it. If you installed another FDC or the system uses no floppy drive, select disabled in this field.

The Choices: Enabled (default), Disabled.

Onboard Serial Port 1

Select an address and corresponding interrupt for the first and second serial ports.

The Choices: 3F8/IRQ4 (default), Disabled, 2F8/IRQ3, 3E8/IRQ4, 2E8/IRQ3, Auto.

Onboard Parallel Port

This item allows you to determine access onboard parallel port controller with which I/O Address.

The Choices: 378/IRQ7 (default), 278/IRQ5, 3BC/IRQ7, Disabled.

Parallel Port Mode

This item allows you to determine how the parallel port should function. The default value is SPP.

P4M900 Micro 775

The Choices:

- SPP (default) Using Parallel port as Standard Printer Port.
- EPP Using Parallel Port as Enhanced Parallel Port.
- ECP Using Parallel port as Extended Capabilities Port.
- ECP+EPP Using Parallel port as ECP & EPP mode.

ECP Mode Use DMA

Select a DMA Channel for the port.

The Choices: 3 (default), 1.

P4M900 Micro 775

USB Device Setting

Press Enter to configure the USB Device.

Phoenix - AwardBIOS CMOS Setup Utility (P4M90-M7)		
USB Device Setting		
USB 1.0 Controller	[Enabled]	Item Help
USB 2.0 Controller	[Enabled]	
USB Operation Mode	[High Speed]	Menu Level >>
USB Keyboard Function	[Enabled]	[Enabled] or [Disable]
USB Mouse Function	[Enabled]	Universal Host
USB Storage Function	[Enabled]	Controller
*** USB Mass Storage Device Boot Setting ***		Interface for Universal
UFDDA	USB Floppy	Serial Bus.
UFDDB	USB Floppy	
No Device	[FDD mode]	
No Device	[Auto mode]	
No Device	[Auto mode]	
No Device	[Auto mode]	
No Device	[Auto mode]	
No Device	[Auto mode]	
No Device	[Auto mode]	
No Device	[Auto mode]	
No Device	[Auto mode]	

USB 1.0/2.0 Controller

These options allow you to enable or disable the USB 1.0/2.0 controller function.

The Choices: Enabled (default), Disabled.

USB Operation Mode

This option let you select the operation mode of USB function.

The Choices: High Speed (default), Full/Low Speed.

USB Keyboard/Mouse/Storage Function

These options allow you to enable or disable the USB keyboard/mouse/storage devices.

The Choices: Enabled (default), Disabled.

USB Mass Storage Device Boot Setting

These options allow you to choose the boot up type of the USB mass storage devices..

The Choices: Auto mode (default), FDD mode, HDD mode.

P4M900 Micro 775

6 Power Management Setup

The Power Management Setup Menu allows you to configure your system to utilize energy conservation and power up/power down features.

■ **Figure 6. Power Management Setup**

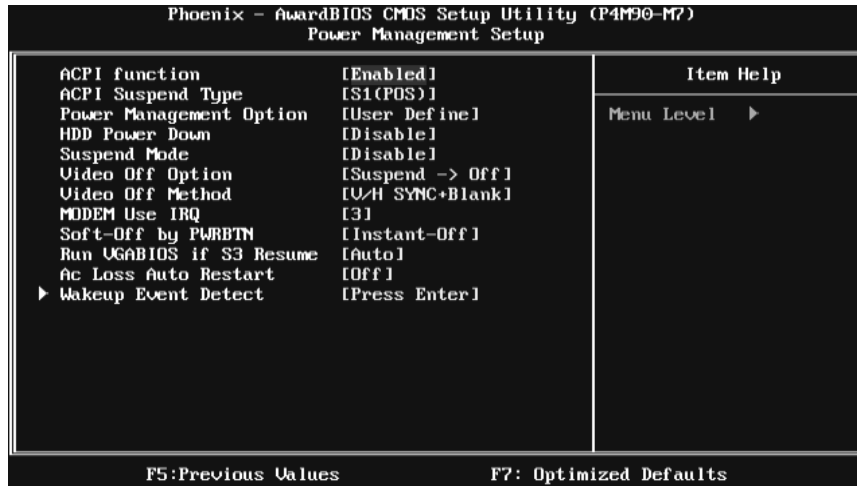

ACPI Function

This item displays the status of the Advanced Configuration and Power Management (ACPI).

The Choices: Enabled (default), Disabled.

ACPI Suspend Type

The item allows you to select the suspend type under the ACPI operating system.

The Choices: S1 (POS) (default) Power on Suspend
S3 (STR) Suspend to RAM
S1 & S3 POS+STR

P4M900 Micro 775

Power Management

This category allows you to select the power saving method and is directly related to the following modes:

1. HDD Power Down.
2. Suspend Mode.

There are three options of Power Management, three of which have fixed mode settings

Min. Power Saving

Minimum power management.

Suspend Mode = 1 hr.

HDD Power Down = 15 min

Max. Power Saving

Maximum power management only available for sl CPU's.

Suspend Mode = 1 min.

HDD Power Down = 1 min.

User Define (default)

Allow you to set each option individually.

When you choose user define, you can adjust each of the item from 1 min. to 1 hr. except for HDD Power Down which ranges from 1 min. to 15 min.

HDD Power Down

When enabled, the hard-disk drives will power down after a set time of system inactivity. All other devices remain active.

The Choices: Disabled (default), 1 Min, 2 Min, 3 Min, 4 Min, 5 Min, 6 Min, 7 Min, 8 Min, 9 Min, 10 Min, 11 Min, 12 Min, 13 Min, 14 Min, 15Min.

Suspend Mode

The item allows you to adjust the system idle time before suspend.

The Choices: Disabled (default), 1 Min, 2 Min, 4 Min, 6 Min, 8 Min, 10 Min, 20 Min, 30 Min, 40 Min, 1 Hour.

Video Off Option

This field determines when to activate the video off feature for monitor power management.

The Choices: Suspend→Off (default), Always on.

P4M900 Micro 775

Video Off Method

This option determines the manner when the monitor goes blank.

V/H SYNC+Blank (default)

This selection will cause the system to turn off the vertical and horizontal synchronization ports and write blanks to the video buffer.

Blank Screen

This option only writes blanks to the video buffer.

DPMS

Initial display power management signaling.

Modem Use IRQ

This determines the IRQ, which can be applied in MODEM use.

The Choices: 3 (default), 4, 5, 7, 9, 10, 11, NA.

Soft-Off by PWRBTN

This item determines the behavior of system power button. Instant off turn off the power immediately, and Delay 4 Sec. will require you to press and hold the power button for 4 seconds to cut off the system power.

The Choices: Delay 4 Sec, **Instant-Off** (default).

Run VGABIOS if S3 Resume

Choosing Enabled will make BIOS run VGA BIOS to initialize the VGA card when system wakes up from S3 state. The system resume time is shortened if you disable the function, but system will need AGP driver to initialize the card. So, if the AGP driver of the VGA card does not support the initialization feature, the display may work abnormally or not function after S3.

The Choices: Auto (default), Yes, No.

Ac Loss Auto Restart

This setting specifies how your system should behave after a power fail or interrupts occurs. By choosing off will leave the computer in the power off state. Choosing On will reboot the computer. Former-Sts will restore the system to the status before power failure or interrupt occurs.

The Choices: Off (default), On, Former-Sts.

P4M900 Micro 775

Wakeup Event Detect

Figure 6.1:IRQ/Event Activity Detect

Highlight the “Press Enter” label next to the “IRQ/Event Activity Detect” label and press the enter key will take you a submenu with the following options:

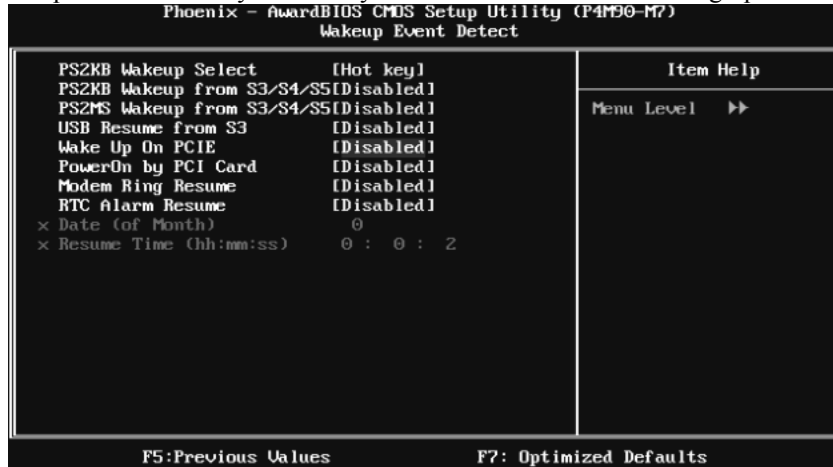

PS2KB Wakeup Select

When select Password, please press Enter key to change password with a maximum length of 8 characters.

The Choices: Hot Key (default), Password.

PS2KB Wakeup from S3/ S4/ S5

This item allows you to wake up from S3/ S4/ S5 with PS2 keyboard.

The Choices: Disabled (default), Ctrl+F1, Ctrl+F2, Ctrl+F3, Ctrl+F4, Ctrl+F5, Ctrl+F6, Ctrl+F7, Ctrl+F8, Ctrl+F9, Ctrl+F10, Ctrl+F11, Ctrl+F12, Power, Wake, Any Key.

PS2MS Wakeup from S3/ S4/ S5

This item allows you to wake up from S3/ S4/ S5 with PS2 mouse.

The Choices: Disabled (default), Enabled.

USB Resume from S3

This item allows you to wake up from S3 with USB device.

P4M900 Micro 775

The Choices: Disabled (default), Enabled.

Wake Up On PCIE

When set to Enabled, PCI-Express device will be able to wake up the system.

For this function to work, you may need a LAN add-on card which supports the Wake on LAN function. Set the Wake on LAN (WOL) jumper on motherboard to enable if applicable.

The Choices: Disabled (default), Enabled.

PowerOn by PCI Card

When you select Enabled, a PME signal from PCI card returns the system to Full ON state.

For this function to work, you may need a LAN add-on card which supports the Wake on LAN function. Set the Wake on LAN (WOL) jumper on motherboard to enable if applicable.

The Choices: Disabled (default), Enabled.

Modem Ring Resume

This item allows you to disable or enable Modem Ring Resume function.

The Choices: Disabled (default), Enabled.

RTC Alarm Resume

When “Enabled”, you can set the date and time at which the RTC (real-time clock) alarm awakens the system from Suspend mode.

The Choices: Disabled (default), Enabled.

Date (of Month)

You can choose which month the system will boot up. This field is only configurable when “RTC Resume” is set to “Enabled”.

Resume Time (hh:mm:ss)

You can choose the hour, minute and second the system will boot up. This field is only configurable when “RTC Resume” is set to “Enabled”.

P4M900 Micro 775

7 PnP/PCI Configurations

This section describes configuring the PCI bus system. PCI, or Personal Computer Interconnect, is a system which allows I/O devices to operate at speeds nearing the speed of the CPU itself uses when communicating with its own special components. This section covers some very technical items and it is strongly recommended that only experienced users should make any changes to the default settings.

■ **Figure 7: PnP/PCI Configurations**



PNP OS Installed

When set to YES, BIOS will only initialize the PnP cards used for the boot sequence (VGA, IDE, SCSI). The rest of the cards will be initialized by the PnP operating system like Window™ 95. When set to NO, BIOS will initialize all the PnP cards. For non-PnP operating systems (DOS, Netware™), this option must set to NO.

The Choices: No (default), Yes.

P4M900 Micro 775

Init Display First

This item allows you to decide to active whether PCI Slot or on-chip VGA first.
The Choices: PCIEx(default), PCISlot, Onboard, AGP.

Reset Configuration Data

The system BIOS supports the PnP feature which requires the system to record which resources are assigned and protects resources from conflict. Every peripheral device has a node, which is called ESCD. This node records which resources are assigned to it. The system needs to record and update ESCD to the memory locations. These locations are reserved in the system BIOS. If the Disabled (default) option is chosen, the system's ESCD will update only when the new configuration varies from the last one. If the Enabled option is chosen, the system is forced to update ESCDs and then is automatically set to the "Disabled" mode.

The above settings will be shown on the screen only if "Manual" is chosen for the resources controlled by function.

Legacy is the term, which signifies that a resource is assigned to the ISA Bus and provides non-PnP ISA add-on cards. PCI / ISA PnP signify that a resource is assigned to the PCI Bus or provides for ISA PnP add-on cards and peripherals.

The Choices: Disabled (default), Enabled.

Resources Controlled By

By Choosing "Auto(ESCD)" (default), the system BIOS will detect the system resources and automatically assign the relative IRQ and DMA channel for each peripheral. By Choosing "Manual", the user will need to assign IRQ & DMA for add-on cards. Be sure that there are no IRQ/DMA and I/O port conflicts.

The Choices: Auto (ESCD) (default), Manual.

P4M900 Micro 775

IRQ Resources

This submenu will allow you to assign each system interrupt a type, depending on the type of device using the interrupt. When you press the “Press Enter” tag, you will be directed to a submenu that will allow you to configure the system interrupts. This is only configurable when “Resources Controlled By” is set to “Manual”.

IRQ-3	assigned to PCI Device
IRQ-4	assigned to PCI Device
IRQ-5	assigned to PCI Device
IRQ-7	assigned to PCI Device
IRQ-9	assigned to PCI Device
IRQ-10	assigned to PCI Device
IRQ-11	assigned to PCI Device
IRQ-12	assigned to PCI Device
IRQ-14	assigned to PCI Device
IRQ-15	assigned to PCI Device

PCI / VGA Palette Snoop

Some old graphic controllers need to “snoop” on the VGA palette and then map it to their display as a way to provide boot information and VGA compatibility. This item allows such snooping to take place.

The Choices: Disabled (default), Enabled

Assign IRQ For VGA

This item allows the users to choose which IRQ to assign for the VGA.

The Choices: Enabled (default), Disabled.

Assign IRQ For USB

This item allows the users to choose which IRQ to assign for the USB.

The Choices: Enabled (default), Disabled.

Maximum Payload Size

Set the maximum payload size for Transaction packets (TLP).

The Choice: 4096 (default.), 128, 256, 512, 1024, 2048.

P4M900 Micro 775

8 PC Health Status

■ Figure 8: PC Health Status

Phoenix - AwardBIOS CMOS Setup Utility (P4M90-M7)		
PC Health Status		
Shutdown Temperature	[85°C/185°F]	Item Help
CPU FAN Control by	[Always ON]	Menu Level ▶
× CPU Fan Load (Sharp=0)	5	
× CPU Fan Start(°C)	24	
× CPU Fan Full speed(°C)	64	
× Start PWM Value(%)	40	
× Slope PWM Level(% /°C)	3.1% /°C Medium	
CPU Ucore		
NB Ucore		
+ 3.3 V		
+ 5.0 V		
+ 12 V		
DRAM Voltage		
VTB Voltage		
Voltage Battery		
Current CPU Temp		
Current CPU FAN Speed		
Current SYS FAN Speed		
Show H/W Monitor in POST	[Enabled]	

F5: Previous Values F7: Optimized Defaults

Shutdown Temperature

This item allows you to set up the CPU shutdown Temperature. This item is only effective under Windows 98 ACPI mode.

The Choices: 70°C / 158°F, 75°C / 167°F, 80°C / 176°F, **85°C / 185°F** (default).

CPU FAN Control by

Choose “smart” to reduce the noise caused by CPU FAN.

The Choices: Smart, **Always On** (default).

CPU Fan Load (Sharp=0)

The Choices: Min=0, Max=7; key in a DEC number.

CPU Fan Start (°C)

CPU fan starts to work under smart fan function when arrive this set value.

The Choices: Min=0, Max=100; key in a DEC number.

P4M900 Micro 775

CPU Fan Full speed <°C >

When CPU temperature is reach the set value, the CPU fan will work under Full Speed.

The Choices: Min=0, Max=100; key in a DEC number.

Start PWM Value (%)

When CPU temperature arrives to the set value, the CPU fan will work under Smart Fan Function mode. The range is from 0~127, with an interval of 1.

The Choices: Min=0, Max=100; key in a DEC number.

Slope PWM Level (%/°C)

Increasing the value of slope PWM will raise the speed of CPU fan.

The Choices: 3.1%/°C Medium(default), 0.0%/°C, 0.8%/°C, 1.6%/°C, 6.3%/°C High, 12.5%/°C, 25.0%/°C, 50.0%/°C.

CPU Vcore, NB Vcore, +3.3V, +5.0V, +12V, DRAM Voltage, VTT Voltage, Voltage Battery

Detect the system's voltage status automatically.

Current CPU Temp

This field displays the current temperature of CPU.

Current CPU FAN Speed

This field displays the current speed of CPU fan.

Current SYS FAN Speed

This field displays the current speed SYSTEM fan.

Show H/W Monitor in POST

If you computer contains a monitoring system, it will show PC health status during POST stage. The item offers several different delay times.

The Choices: Enabled (default), Disabled.

P4M900 Micro 775

9 Performance Booster Zone

■ Figure 9: Performance Booster Zone



DRAM Clock/Drive Control

This item controls the DRAM Clock. Highlight “Press Enter” next to the “DRAM Clock/Drive Control” label and pressing the enter key will take you a submenu with the following options:

■ Figure 9.1: DRAM Clock/Drive Control



P4M900 Micro 775

DRAM Clock

This item determines DRAM clock.

The Choices: By SPD (default), 100MHz, 133MHz, 166MHz, 200MHz, 266MHz, 333MHz.

DRAM Timing

This item determines DRAM clock/ timing.

The Choices: Auto by SPD (default), Manual, Turbo, Ultra.

SDRAM CAS Latency

When DRAM is installed, the number of clock cycles of CAS latency depends on the DRAM timing.

The Choices: 2.5/4(default).

Bank Interleave

This item allows you to enable or disable the bank interleave feature.

The Choices: Disabled (default).

Precharge to Active (tRP)

This item allows you to specify the delay from precharge command to activate command.

The Choices: 4T (default).

Active to Precharge (tRAS)

This item allows you to specify the minimum row active time (tRAS).

The Choices: 07T (default).

Active to CMD (tRCD)

Use this item to specify the delay from the activation of a bank to the time that a read or write command is accepted.

The Choices: 4T (default).

REF to ACT/REF to REF (Trfc)

This item allows you to determine the selection for REF to ACT/REF to REF (tRFC).

The Choices: 20T/21T (default).

P4M900 Micro 775

ACT (0) to ACT (1) (tRRD)

This item allows you to determine the selection for ACT (0) to ACT (1) (tRRD)

The Choices: 3T (default).

1T CMD Support

The Choices: Disable (default), Auto.

DDR2 On Die Termination

This option allows you to choose the working type of ODT.

The Choices: ODT Always ON (default), Dynamic ODT, ODT Always OFF.

CPU CLOCK

This item allows you to select CPU Clock, and CPU over clocking.

Special Notice:

If the system's frequency that you are selected is not functioning, there are two methods of booting-up the system.

Method 1:

Clear the COMS data by setting the JCOMS1 ((2-3) closed) as "ON" status. All the CMOS data will be loaded as defaults setting.

Method 2:

Press the <Insert> key and Power button simultaneously, after that keep-on pressing the <Insert> key until the power-on screen showed.

This action will boot-up the system according to FSB of the processor

It's strongly recommended to set CPU Vcore and clock in default setting. If the CPU Vcore and clock are not in default setting, it may cause CPU or M/B damage.

The Choices: 100MHz(default); Min=100, Max=400, key in a DEC number.

Async PCIE CLOCK

This item allows you to select Async PCIE clock.

Min= 100 Max=150 Key in a DEC number.

The Choices: 100MHz(default) ; Min=100, Max=150, key in a DEC number.

CPU Clock Ratio

This item allows you to select the CPU Ratio.

Min= 6 Max= 50 Key in a DEC number.

The Choices: 6X (default).

P4M900 Micro 775

Spread Spectrum

This item allows you to enable/disable the Spread Spectrum function.
The Choices: +/- **0.25%** (default), +/- 0.5%, Disabled, -0.5%, -1.0%.

DDR Voltage

This item allows you to select DDR Voltage.
The Choices: **StartUp** (default), +0.10V, +0.20V, +0.30V, +0.40V, +0.50V, +0.60V, +0.70V.

CPU Voltage

This item allows you to select CPU Voltage.
The Choices: **StartUp** (default), +0.012V~+0.787V.