

FCC Information and Copyright

This equipment has been tested and found to comply with the limits of a Class B digital device, pursuant to Part 15 of the FCC Rules. These limits are designed to provide reasonable protection against harmful interference in a residential installation. This equipment generates, uses, and can radiate radio frequency energy and, if not installed and used in accordance with the instructions, may cause harmful interference to radio communications. There is no guarantee that interference will not occur in a particular installation.

The vendor makes no representations or warranties with respect to the contents here and specially disclaims any implied warranties of merchantability or fitness for any purpose. Further the vendor reserves the right to revise this publication and to make changes to the contents here without obligation to notify any party beforehand.

Duplication of this publication, in part or in whole, is not allowed without first obtaining the vendor's approval in writing.

The content of this user's manual is subject to be changed without notice and we will not be responsible for any mistakes found in this user's manual. All the brand and product names are trademarks of their respective companies.

Table of Contents

Chapter 1: Introduction	1
1.1 Before You Start	1
1.2 Package Checklist	1
1.3 Motherboard Features	2
1.4 Rear Panel Connectors	3
1.5 Motherboard Layout	4
Chapter 2: Hardware Installation	5
2.1 Installing Central Processing Unit (CPU)	5
2.2 FAN Headers	7
2.3 Installing System Memory	8
2.4 Connectors and Slots	10
Chapter 3: Headers & Jumpers Setup	12
3.1 How to Setup Jumpers	12
3.2 Detail Settings	12
Chapter 4: Useful Help	19
4.1 Driver Installation Note	19
4.2 Software	20
4.3 Extra Information	24
4.4 AMI BIOS Beep Code	26
4.5 Troubleshooting	27
Appendix: SPEC In Other Languages	28
German	28
France	30
Italian	32
Spanish	34
Portuguese	36
Polish	38
Russian	40
Arabic	42
Japanese	44

CHAPTER 1: INTRODUCTION

1.1 BEFORE YOU START

Thank you for choosing our product. Before you start installing the motherboard, please make sure you follow the instructions below:

- Prepare a dry and stable working environment with sufficient lighting.
- Always disconnect the computer from power outlet before operation.
- Before you take the motherboard out from anti-static bag, ground yourself properly by touching any safely grounded appliance, or use grounded wrist strap to remove the static charge.
- Avoid touching the components on motherboard or the rear side of the board unless necessary. Hold the board on the edge, do not try to bend or flex the board.
- Do not leave any unfastened small parts inside the case after installation. Loose parts will cause short circuits which may damage the equipment.
- Keep the computer from dangerous area, such as heat source, humid air and water.

1.2 PACKAGE CHECKLIST

- ✚ IDE Cable X 1
- ✚ Serial ATA Cable X 1
- ✚ Rear I/O Panel for ATX Case X 1
- ✚ User's Manual X 1
- ✚ Fully Setup Driver CD X 1
- ✚ FDD Cable X 1 (optional)
- ✚ USB 2.0 Cable X1 (optional)
- ✚ Serial ATA Power Cable X 1 (optional)

Note: The package contents may differ by area or your motherboard version.

1.3 MOTHERBOARD FEATURES

	<i>P45D2-A7</i>	<i>P43-A7</i>
CPU	LGA 775 Intel Core2Duo / Core2Quad / Pentium Dual-Core / Celeron Dual-Core / Celeron 4xx processor Supports Execute Disable Bit / Enhanced Intel SpeedStep® / Intel Architecture-64 / Extended Memory 64 Technology / Virtualization Technology	LGA 775 Intel Core2Duo / Core2Quad / Pentium Dual-Core / Celeron Dual-Core / Celeron 4xx processor Supports Execute Disable Bit / Enhanced Intel SpeedStep® / Intel Architecture-64 / Extended Memory 64 Technology / Virtualization Technology
FSB	Support 800 / 1066 / 1333 / 1600 MHz	Support 800 / 1066 / 1333 / 1600 MHz
Chipset	Intel P45 Intel ICH10	Intel P43 Intel ICH10
Super I/O	ITE 8718F Provides the most commonly used legacy Super I/O functionality. Low Pin Count Interface Environment Control initiatives, Hardware Monitor Controller Fan Speed Controller ITE's "Smart Guardian" function	ITE 8718F Provides the most commonly used legacy Super I/O functionality. Low Pin Count Interface Environment Control initiatives, Hardware Monitor Controller Fan Speed Controller ITE's "Smart Guardian" function
Main Memory	DIMM Slots x 4 Each DIMM supports 256MB / 512MB / 1GB / 2GB DDR2 Max Memory Capacity 8GB Dual Channel Mode DDR2 memory module Supports DDR2 1066 / 800 / 667 Registered DIMM and ECC DIMM is not supported	DIMM Slots x 4 Each DIMM supports 256MB / 512MB / 1GB / 2GB DDR2 Max Memory Capacity 8GB Dual Channel Mode DDR2 memory module Supports DDR2 1066 / 800 / 667 Registered DIMM and ECC DIMM is not supported
IDE	JMicro JMB368 Ultra DMA 33 / 66 / 100 / 133 Bus Master Mode supports PIO Mode 0~4	JMicro JMB368 Ultra DMA 33 / 66 / 100 / 133 Bus Master Mode supports PIO Mode 0~4
SATA 2	Integrated Serial ATA Controller Data transfer rates up to 3.0 Gb/s. SATA Version 2.0 specification compliant	Integrated Serial ATA Controller Data transfer rates up to 3.0 Gb/s. SATA Version 2.0 specification compliant
LAN	Realtek RTL 8111C 10 / 100 / 1000 Mb/s auto negotiation Half / Full duplex capability	Realtek RTL 8111C 10 / 100 / 1000 Mb/s auto negotiation Half / Full duplex capability
Sound Codec	ALC662 5.1 channels audio out High Definition Audio	ALC662 5.1 channels audio out High Definition Audio

P45D2-A7/P43-A7

	P45D2-A7		P43-A7	
Slots	PCI slot	x3	PCI slot	x3
	PCI Express Gen2 x 16 slot	x1	PCI Express Gen2 x 16 slot	x1
	PCI Express x 1 slot	x1	PCI Express x 1 slot	x1
On Board Connector	Floppy connector	x1	Floppy connector	x1
	Printer Port Connector	x1	Printer Port Connector	x1
	Serial port Connector	x1	Serial port Connector	x1
	IDE Connector	x1	IDE Connector	x1
	SATA Connector	x6	SATA Connector	x6
	Front Panel Connector	x1	Front Panel Connector	x1
	Front Audio Connector	x1	Front Audio Connector	x1
	CD-in Connector	x1	CD-in Connector	x1
	CPU Fan header	x1	CPU Fan header	x1
	System Fan header	x1	System Fan header	x1
	Clear CMOS header	x1	Clear CMOS header	x1
	USB connector	x3	USB connector	x3
	Power Connector (24pin)	x1	Power Connector (24pin)	x1
Power Connector (4pin)	x1	Power Connector (4pin)	x1	
Back Panel I/O	PS/2 Keyboard	x1	PS/2 Keyboard	x1
	PS/2 Mouse	x1	PS/2 Mouse	x1
	LAN port	x1	LAN port	x1
	USB Port	x6	USB Port	x6
	Audio Jack	x3	Audio Jack	x3
Board Size	205 (W) x 305 (L) mm		205 (W) x 305 (L) mm	
OS Support	Windows 2000 / XP / VISTA Biostar Reserves the right to add or remove support for any OS with or without notice		Windows 2000 / XP / VISTA Biostar Reserves the right to add or remove support for any OS with or without notice	

1.4 REAR PANEL CONNECTORS

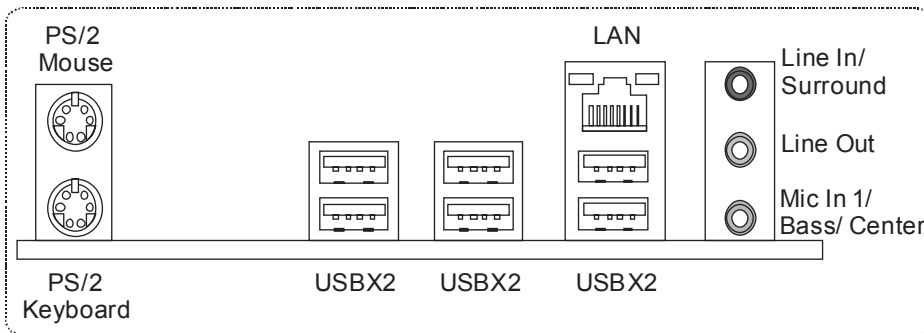

1.5 MOTHERBOARD LAYOUT

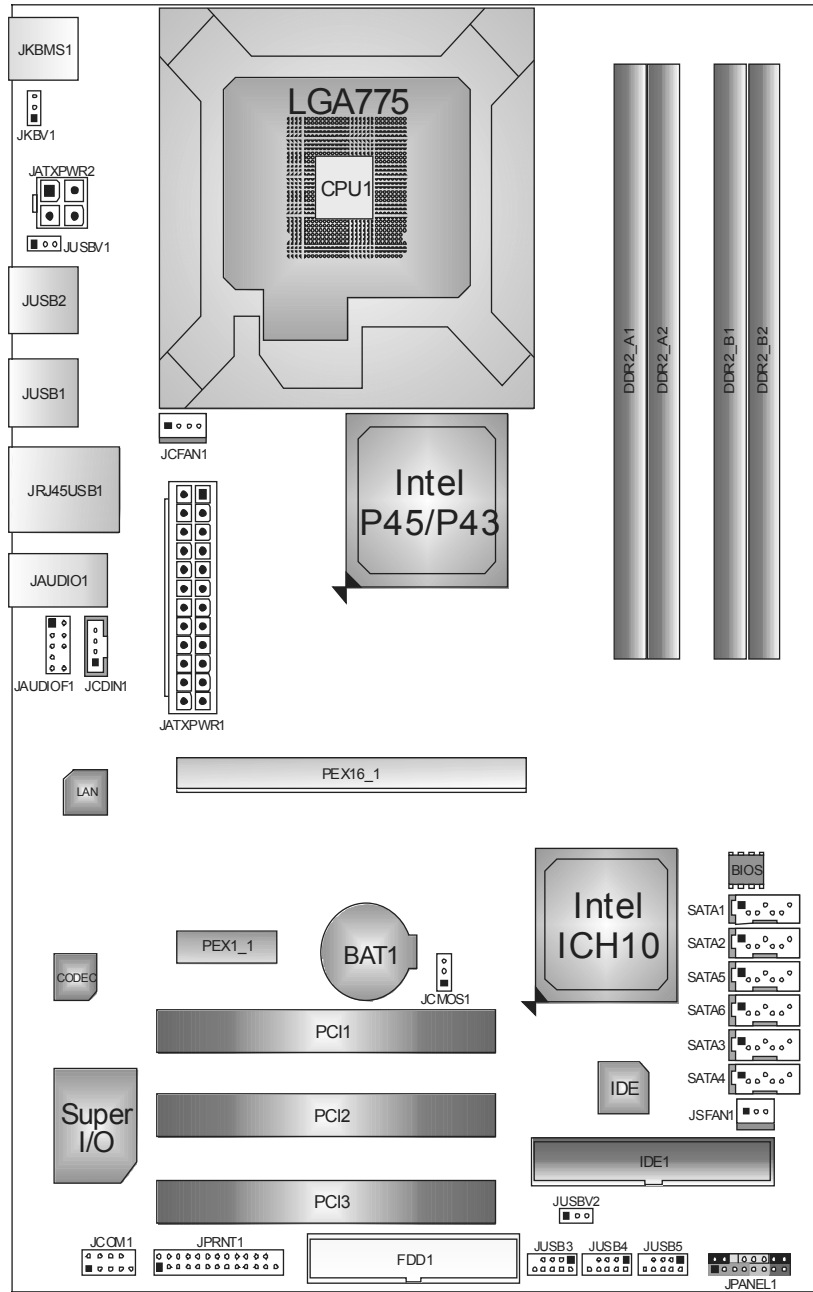

Note: ■ represents the 1st pin.

CHAPTER 2: HARDWARE INSTALLATION

2.1 INSTALLING CENTRAL PROCESSING UNIT (CPU)

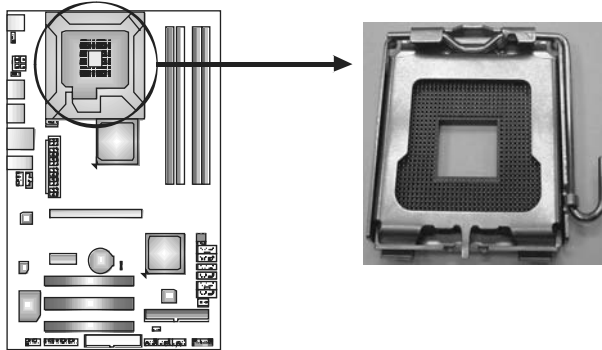

Special Notice:

Remove Pin Cap before installation, and make good preservation for future use. When the CPU is removed, cover the Pin Cap on the empty socket to ensure pin legs won't be damaged.

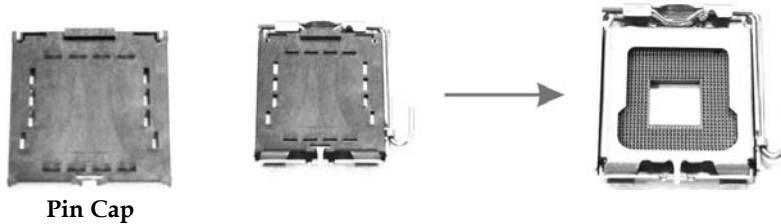

Step 1: Pull the socket locking lever out from the socket and then raise the lever up to a 90-degree angle.

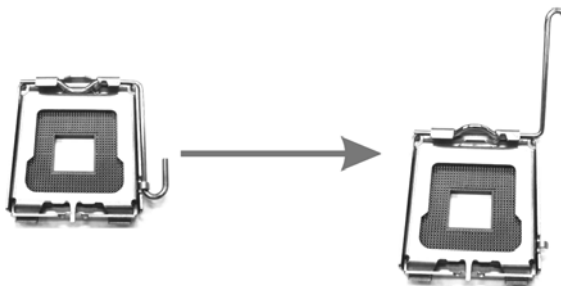

Motherboard Manual

Step 2: Look for the triangular cut edge on socket, and the golden dot on CPU should point forwards this triangular cut edge. The CPU will fit only in the correct orientation.

Step 2-1:

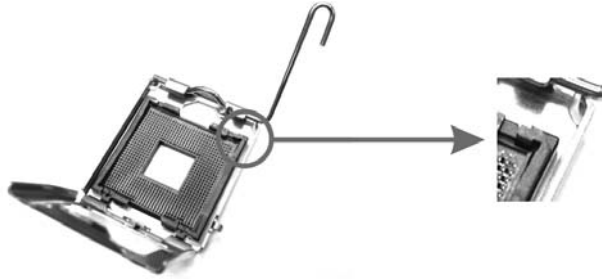

Step 2-2:

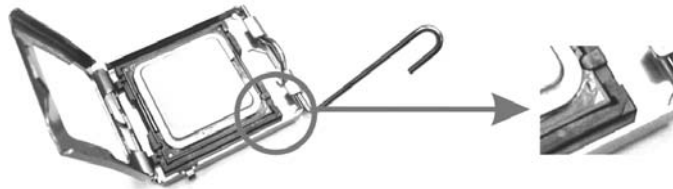

Step 3: Hold the CPU down firmly, and then lower the lever to locked position to complete the installation.



Step 4: Put the CPU Fan and heatsink assembly on the CPU and buckle it on the retention frame. Connect the CPU FAN power cable into the JCFAN1. This completes the installation.

2.2 FAN HEADERS

These fan headers support cooling-fans built in the computer. The fan cable and connector may be different according to the fan manufacturer. Connect the fan cable to the connector while matching the black wire to pin#1.

JCFAN1: CPU Fan Header

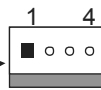
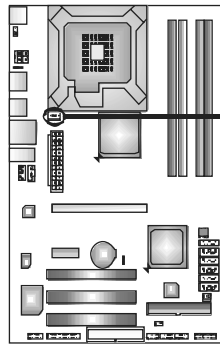

Pin	Assignment
1	Ground
2	+12V
3	FAN RPM rate sense
4	Smart Fan Control

JSFAN1: System Fan Header

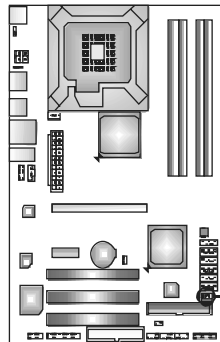

Pin	Assignment
1	Ground
2	+12V
3	FAN RPM rate sense

Note:

The JSFAN1 support 3-pin head connector, and the JCFAN1 supports 4-pin head connector. When connecting with wires onto connectors, please note that the red wire is the positive and should be connected to pin#2, and the black wire is Ground and should be connected to GND.

2.3 INSTALLING SYSTEM MEMORY

A. Memory Modules

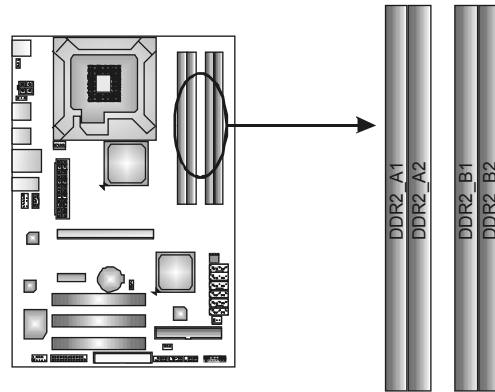

1. Unlock a DIMM slot by pressing the retaining clips outward. Align a DIMM on the slot such that the notch on the DIMM matches the break on the Slot.

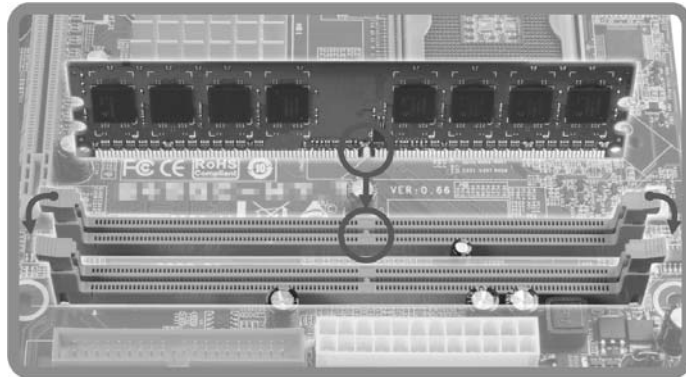

2. Insert the DIMM vertically and firmly into the slot until the retaining chip snap back in place and the DIMM is properly seated.

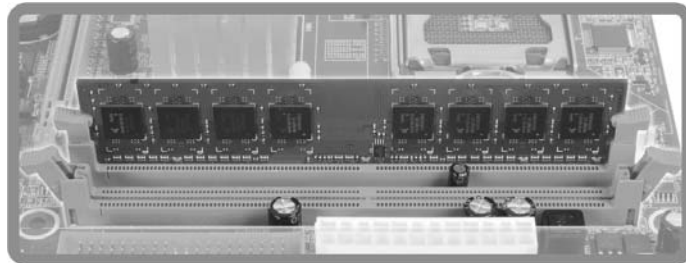

B. Memory Capacity

DIMM Socket Location	DDR2 Module	Total Memory Size
DDR2_A1	256MB/512MB/1GB/2GB	Max is 8GB.
DDR2_A2	256MB/512MB/1GB/2GB	
DDR2_B1	256MB/512MB/1GB/2GB	
DDR2_B2	256MB/512MB/1GB/2GB	

C. Dual Channel Memory installation

To trigger the Dual Channel function of the motherboard, the memory module must meet the following requirements:

Install memory module of the same density in pairs, shown in the following table.

Dual Channel Status	DDR2_A1	DDR2_A2	DDR2_B1	DDR2_B2
Enabled	O	X	O	X
Enabled	X	O	X	O
Enabled	O	O	O	O

(O means memory installed, X means memory not installed.)

The DRAM bus width of the memory module must be the same (x8 or x16)

2.4 CONNECTORS AND SLOTS

FDD1: Floppy Disk Connector

The motherboard provides a standard floppy disk connector that supports 360K, 720K, 1.2M, 1.44M and 2.88M floppy disk types. This connector supports the provided floppy drive ribbon cables.

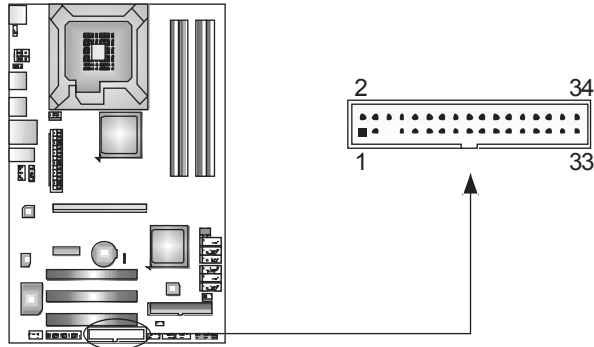

IDE1: IDE/ATAPI Connector

The motherboard has a 32-bit Enhanced PCI IDE Controller that provides PIO Mode 0~4, Bus Master, and Ultra DMA 33/66/100/133 functionality.

The IDE connector can connect a master and a slave drive, so you can connect up to two drives.

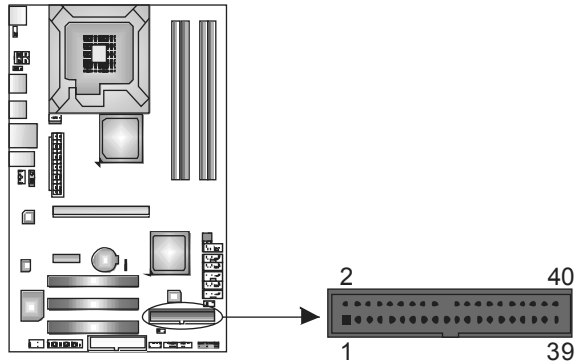

PEX16_1: PCI-Express Gen2 x16 Slot

- PCI-Express 2.0 compliant.
- Maximum theoretical realized bandwidth of 8GB/s simultaneously per direction, for an aggregate of 16GB/s totally.
- PCI-Express Gen2 supports a raw bit-rate of 5.0Gb/s on the data pins.
- 2X bandwidth over the PCI-Express 1.1 architecture.

PEX1_1: PCI-Express x1 Slot

- PCI-Express 1.1 compliant.
- Data transfer bandwidth up to 250MB/s per direction; 500MB/s in total.
- PCI-Express supports a raw bit-rate of 2.5Gb/s on the data pins.
- 2X bandwidth over the PCI architecture.

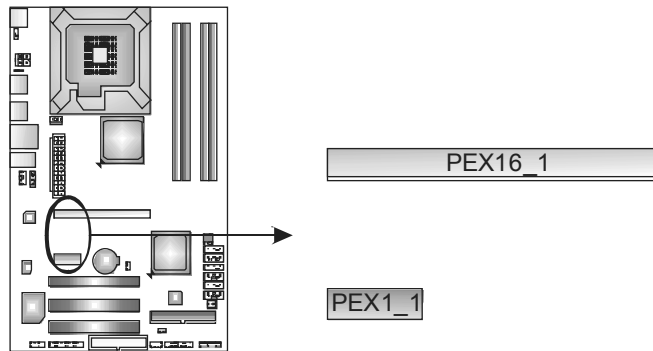

PCI1~PCI3: Peripheral Component Interconnect Slots

This motherboard is equipped with 3 standard PCI slots. PCI stands for Peripheral Component Interconnect, and it is a bus standard for expansion cards. This PCI slot is designated as 32 bits.

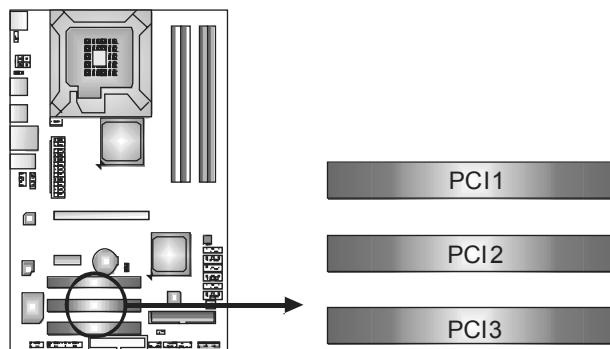

CHAPTER 3: HEADERS & JUMPERS SETUP

3.1 HOW TO SETUP JUMPERS

The illustration shows how to set up jumpers. When the jumper cap is placed on pins, the jumper is “close”, if not, that means the jumper is “open”.



3.2 DETAIL SETTINGS

JPANEL1: Front Panel Header

This 16-pin connector includes Power-on, Reset, HDD LED, Power LED, and speaker connection. It allows user to connect the PC case’s front panel switch functions.

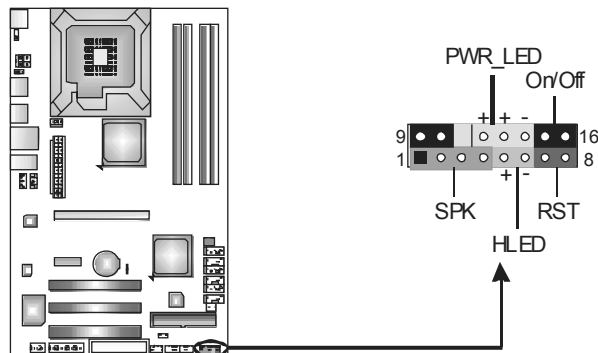

Pin	Assignment	Function	Pin	Assignment	Function
1	+5V	Speaker Connector	9	N/A	N/A
2	N/A		10	N/A	
3	N/A		11	N/A	
4	Speaker	Hard drive LED	12	Power LED (+)	Power LED
5	HDD LED (+)		13	Power LED (+)	
6	HDD LED (-)	Reset button	14	Power LED (-)	Power-on button
7	Ground		15	Power button	
8	Reset control		16	Ground	

JATXPWR1: ATX Power Source Connector

This connector allows user to connect 24-pin power connector on the ATX power supply.

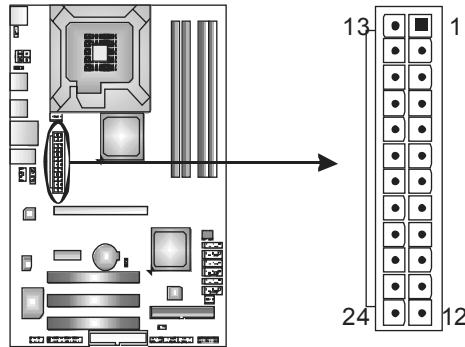

Pin	Assignment	Pin	Assignment
13	+3.3V	1	+3.3V
14	-12V	2	+3.3V
15	Ground	3	Ground
16	PS_ON	4	+5V
17	Ground	5	Ground
18	Ground	6	+5V
19	Ground	7	Ground
20	NC	8	PW_OK
21	+5V	9	Standby Voltage+5V
22	+5V	10	+12V
23	+5V	11	+12V
24	Ground	12	+3.3V

JATXPWR2: ATX Power Source Connector

By connecting this connector, it will provide +12V to CPU power circuit.

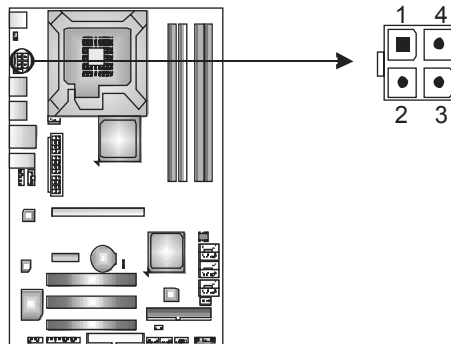

Pin	Assignment
1	+12V
2	+12V
3	Ground
4	Ground

Note:

Before power on the system, please make sure that both JATXPWR1 and JATXPWR2 connectors have been plugged-in.

SATA1~SATA6: Serial ATA Connectors

The motherboard has a PCI to SATA Controller with 6 channels SATA interface, it satisfies the SATA 2.0 spec and with transfer rate of 3.0Gb/s.

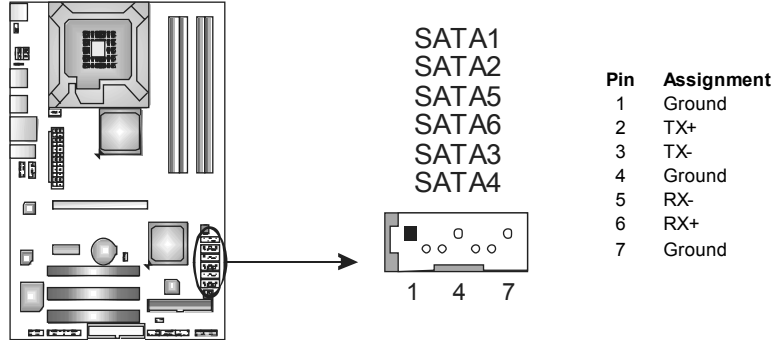

JUSB3/JUSB4/JUSB5: Headers for USB 2.0 Ports at Front Panel

This header allows user to connect additional USB cable on the PC front panel, and also can be connected with internal USB devices, like USB card reader.

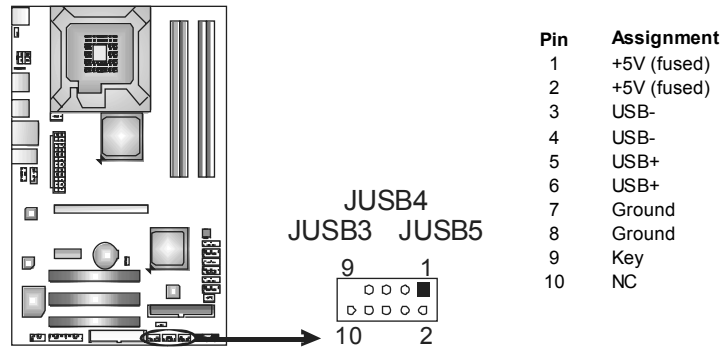

JAUDIOF1: Front Panel Audio Header

This header allows user to connect the front audio output cable with the PC front panel. This header allows only HD audio front panel connector; AC'97 connector is not acceptable.

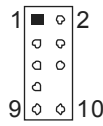
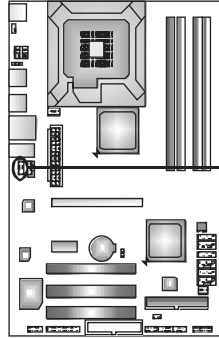

Pin	Assignment
1	Mic Left in
2	Ground
3	Mic Right in
4	GPIO
5	Right line in
6	Jack Sense
7	Front Sense
8	Key
9	Left line in
10	Jack Sense

JCDIN1: CD-ROM Audio-in Connector

This connector allows user to connect the audio source from the variety devices, like CD-ROM, DVD-ROM, PCI sound card, PCI TV turner card etc..

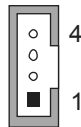
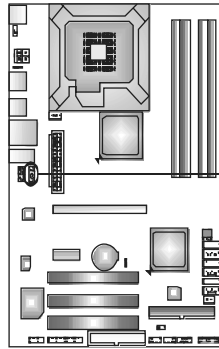

Pin	Assignment
1	Left Channel Input
2	Ground
3	Ground
4	Right Channel Input

JCMOS1: Clear CMOS Header

By placing the jumper on pin2-3, it allows user to restore the BIOS safe setting and the CMOS data, please carefully follow the procedures to avoid damaging the motherboard.

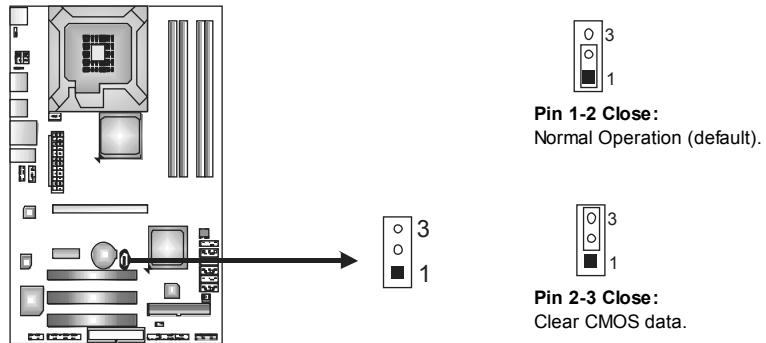

※ Clear CMOS Procedures:

1. Remove AC power line.
2. Set the jumper to "Pin 2-3 close".
3. Wait for five seconds.
4. Set the jumper to "Pin 1-2 close".
5. Power on the AC.
6. Reset your desired password or clear the CMOS data.

JCOM1: Serial port Connector

The motherboard has a Serial Port Connector for connecting RS-232 Port.

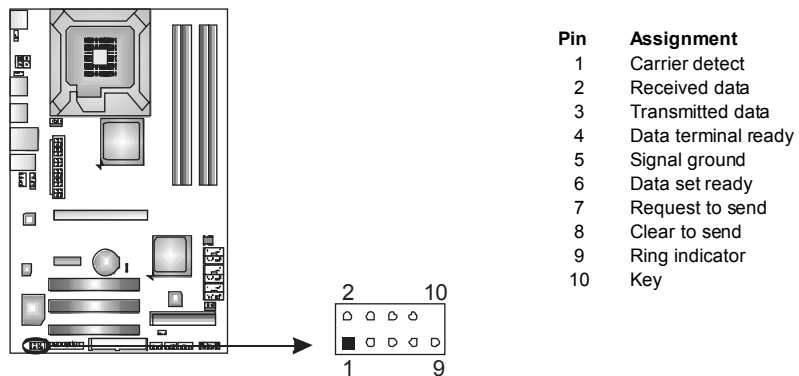

JPRNT1: Printer Port Connector

This header allows you to connect printer on the PC.

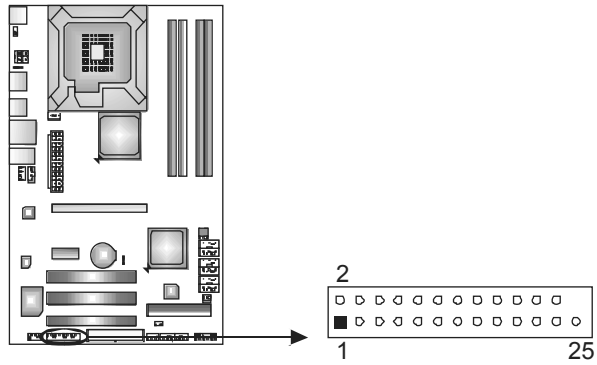

Pin	Assignment	Pin	Assignment
1	-Strobe	14	Ground
2	-ALF	15	Data 6
3	Data 0	16	Ground
4	-Error	17	Data 7
5	Data 1	18	Ground
6	-Init	19	-ACK
7	Data 2	20	Ground
8	-Scltin	21	Busy
9	Data 3	22	Ground
10	Ground	23	PE
11	Data 4	24	Ground
12	Ground	25	SCLT
13	Data 5	26	Key

JUSBV1/JUSBV2: Power Source Headers for USB Ports

Pin 1-2 Close:

JUSBV1: +5V for USB ports at JUSB1/JUSB2/JRJ45USB1.

JUSBV2: +5V for USB ports at JUSB3/JUSB4/JUSB5.

Pin 2-3 Close:

JUSBV1: +5V STB for USB ports at JUSB1/JUSB2/ JRJ45USB1.

JUSBV2: +5V STB for USB ports at JUSB3/JUSB4/JUSB5.

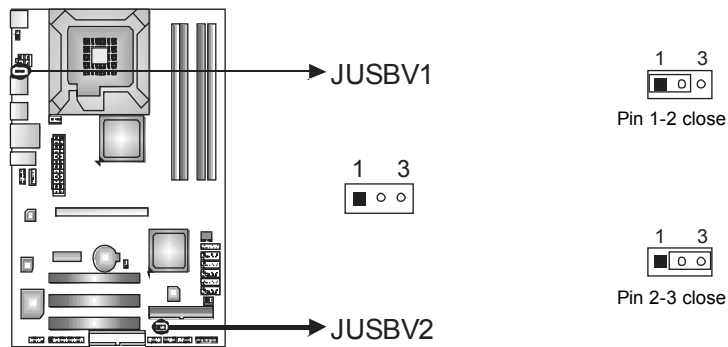

JKBV1: Power Source Header for PS/2 Keyboard and Mouse

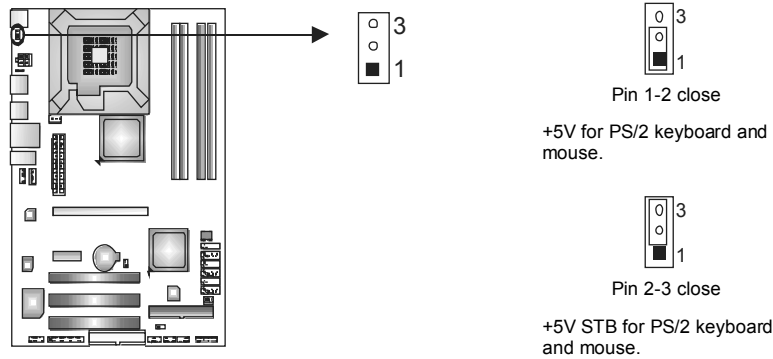

CHAPTER 4: USEFUL HELP

4.1 DRIVER INSTALLATION NOTE

After you installed your operating system, please insert the Fully Setup Driver CD into your optical drive and install the driver for better system performance.

You will see the following window after you insert the CD



The setup guide will auto detect your motherboard and operating system.

Note:

If this window didn't show up after you insert the Driver CD, please use file browser to locate and execute the file **SETUP.EXE** under your optical drive.

A. Driver Installation

To install the driver, please click on the Driver icon. The setup guide will list the compatible driver for your motherboard and operating system. Click on each device driver to launch the installation program.

B. Software Installation

To install the software, please click on the Software icon. The setup guide will list the software available for your system, click on each software title to launch the installation program.

C. Manual

Aside from the paperback manual, we also provide manual in the Driver CD. Click on the Manual icon to browse for available manual.

Note:

You will need Acrobat Reader to open the manual file. Please download the latest version of Acrobat Reader software from <http://www.adobe.com/products/acrobat/readstep2.html>

4.2 SOFTWARE

Installing Software

1. Insert the Setup CD to the optical drive. The drivers installation program would appear if the Autorun function has been enabled.
2. Select **Software Installation**, and then click on the respective software title.
3. Follow the on-screen instructions to complete the installation.

Launching Software

After the installation process, you will see the software icon “eHOT Line” / “BIOS Update” appears on the desktop. Double-click the icon to launch the utility.

eHot-Line (Optional)

eHot-Line is a convenient utility that helps you to contact with our Tech-Support system. This utility will collect the system information which is useful for analyzing the problem you may have encountered, and then send these information to our tech-support department to help you fix the problem.



Before you use this utility, please set Outlook Express as your default e-mail client application program.

*represents important information that you must provide. Without this information, you may not be able to send out the mail.

The screenshot shows the eHot-Line utility window. On the left, there is a list of system information under the heading "Base board information :". The information includes: Caption : Base Board, CreationClassName : Win32_Base, Description : Base Board, HostingBoard : TRUE, HotSwappable : FALSE, Manufacturer : BIOSTAR Group, Name : Base Board, PoweredOn : TRUE, Product : TA780G M2+, Removable : FALSE, Replaceable : TRUE, RequiresDaughterBoard : FALSE, SerialNumber : None, Status : OK, Tag : Base Board, and Version : 6.0. On the right, there is a "Symptom Description :" text area. Below this are several input fields: "Region :", "CC E-mail :", "Memory Module Manufacture :", and "Power Supply Manufacture/model :". At the bottom, there are three buttons: "Send", "Save As...", and "Exit".

Annotations for the screenshot:

- "This block will show the information which would be collected in the mail." points to the system information list.
- "*Describe condition of your system." points to the Symptom Description text area.
- "*Select your area or the area close to you." points to the Region dropdown menu.
- "Provide the e-mail address that you would like to send the copy to." points to the CC E-mail input field.
- "*Provide the name of the memory module manufacturer." points to the Memory Module Manufacture input field.
- "Provide the name of the power supply manufacturer and the model no." points to the Power Supply Manufacture/model input field.
- "Send the mail out." points to the Send button.
- "Save these information to a .txt file" points to the Save As... button.
- "Exit this dialog." points to the Exit button.

After filling up this information, click **“Send”** to send the mail out. A warning dialog would appear asking for your confirmation; click **“Send”** to confirm or **“Do Not Send”** to cancel.



If you want to save this information to a .txt file, click **“Save As...”** and then you will see a saving dialog appears asking you to enter file name.

Enter the file name and then click **“Save”**. Your system information will be saved to a .txt file.

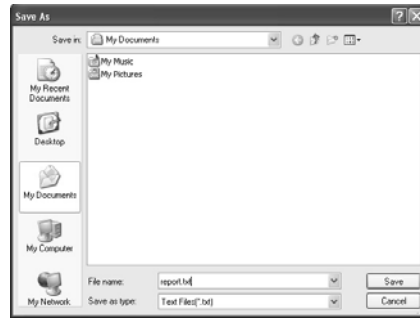

Open the saved .txt file, you will see your system information including motherboard/BIOS/CPU/video/device/OS information. This information is also concluded in the sent mail.



We will not share customer’s data with any other third parties, so please feel free to provide your system information while using eHot-Line service.



If you are not using Outlook Express as your default e-mail client application, you may need to save the system information to a .txt file and send the file to our tech support with other e-mail application. Go to the following web <http://www.biostar.com.tw/app/en-us/about/contact.php> for getting our contact information.

BIOS Update

BIOS Update is a convenient utility which allows you to update your motherboard BIOS under Windows system.

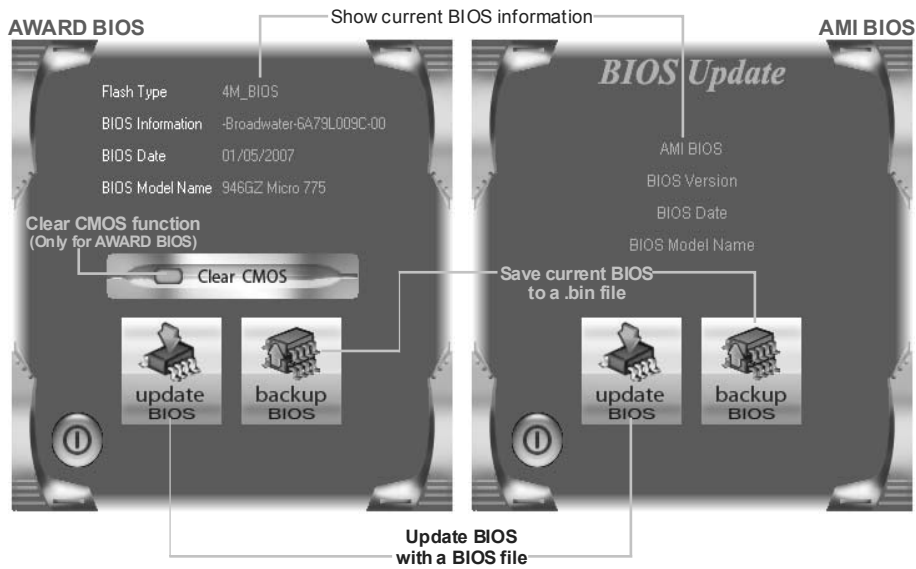

<Backup BIOS>

Once click on this button, the saving dialog will show. Choose the position to save file and enter file name. (We recommend that the file name should be English/number and no longer than 7 characters.) Then click **Save**.

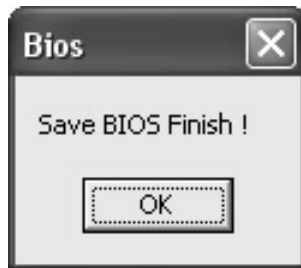
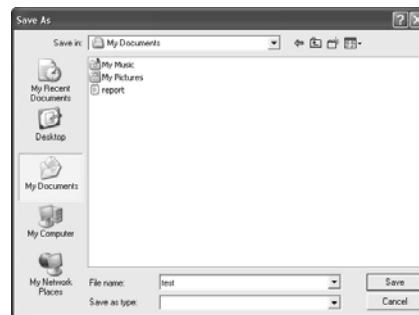

After the saving process, finish dialog will show. Click on **OK** to complete the BIOS Backup procedure.

<Update BIOS>

Before doing this, please download the proper BIOS file from the website.

For AWARD BIOS, update BIOS procedure should be run with Clear CMOS function, so please check on Clear CMOS first.

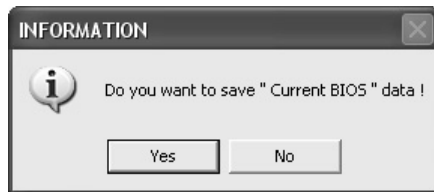

Then click Update BIOS button, a dialog will show for asking you backup current BIOS. Click **Yes** for BIOS backup and refer to the Backup BIOS procedure; or click **No** to skip this procedure.

After the BIOS Backup procedure, the open dialog will show for requesting the BIOS file which is going to be updated. Please choose the proper BIOS file for updating, then click on **Open**.

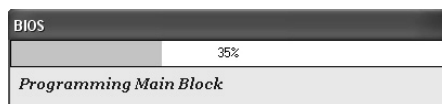
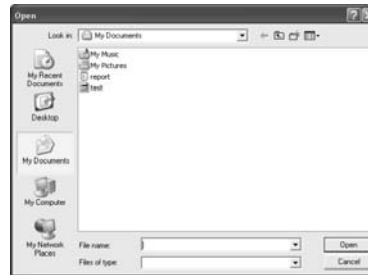

The utility will update BIOS with the proper BIOS file, and this process may take minutes. Please do not open any other applications during this process.

After the BIOS Update process, click on **OK** to restart the system.

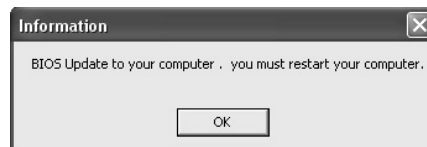

While the system boots up and the full screen logo shows, press  <Delete> key to enter BIOS setup.

In the BIOS setup, use the **Load Optimized Defaults** function and then **Save and Exit Setup** to exit BIOS setup. BIOS Update is completed.



All the information and content above about the software are subject to be changed without notice. For better performance, the software is being continuously updated. The information and pictures described above are for your reference only. The actual information and settings on board may be slightly different from this manual.

4.3 EXTRA INFORMATION

CPU Overheated

If the system shutdown automatically after power on system for seconds, that means the CPU protection function has been activated.

When the CPU is over heated, the motherboard will shutdown automatically to avoid a damage of the CPU, and the system may not power on again.

In this case, please double check:

1. The CPU cooler surface is placed evenly with the CPU surface.
2. CPU fan is rotated normally.
3. CPU fan speed is fulfilling with the CPU speed.

After confirmed, please follow steps below to relief the CPU protection function.

1. Remove the power cord from power supply for seconds.
2. Wait for seconds.
3. Plug in the power cord and boot up the system.

Or you can:

1. Clear the CMOS data.
(See "Close CMOS Header: JCMOS1" section)
2. Wait for seconds.
3. Power on the system again.

BIO-Flasher

BIO-Flasher is a BIOS flashing utility providing you an easy and simple way to update your BIOS via USB pen drive or floppy disk.

The BIO-Flasher is built in the BIOS chip. To enter the utility, **press <F12> during the Power-On Self Tests (POST)** procedure while booting up.

Updating BIOS with BIO-Flasher

1. Go to the website to download the latest BIOS file for the motherboard.
2. Then, save the BIOS file into a USB pen drive or a floppy disk.
3. Insert the USB pen drive or the floppy disk that contains the BIOS file to the USB port or the floppy disk drive.
4. Power on or reset the computer and then press **<F12>** during the **POST** process. A select dialog as the picture on the right appears. Select the device contains the BIOS file and press **<Enter>** to enter the utility.



5. The utility will show the BIOS files and their respective information. Select the proper BIOS file and press **<Enter>** then **<Y>** to perform the BIOS update process.

6. After the update process, the utility will ask you to reboot the system. Press **<Y>** to proceed. BIOS update completes.



- This utility only allows storage device with FAT32/16 format and single partition.
- Shutting down or resetting the system while updating the BIOS will lead to system boot failure.

4.4 AMI BIOS BEEP CODE

Boot Block Beep Codes

Number of Beeps	Description
1	No media present. (Insert diskette in floppy drive A:)
2	"AMIBOOT.ROM" file not found in root directory of diskette in A:
3	Insert next diskette if multiple diskettes are used for recovery
4	Flash Programming successful
5	File read error
7	No Flash EPROM detected
10	Flash Erase error
11	Flash Program error
12	"AMIBOOT.ROM" file size error
13	BIOS ROM image mismatch (file layout does not match image present in flash device)

POST BIOS Beep Codes

Number of Beeps	Description
1	Memory refresh timer error
3	Base memory read/write test error
6	Keyboard controller BAT command failed
7	General exception error (processor exception interrupt error)
8	Display memory error (system video adapter)

Troubleshooting POST BIOS Beep Codes

Number of Beeps	Troubleshooting Action
1, 3	Reseat the memory, or replace with known good modules.
6, 7	<p>Fatal error indicating a serious problem with the system. Consult your system manufacturer. Before declaring the motherboard beyond all hope, eliminate the possibility of interference by a malfunctioning add-in card. Remove all expansion cards except the video adapter.</p> <ul style="list-style-type: none"> ● If beep codes are generated when all other expansion cards are absent, consult your system manufacturer's technical support. ● If beep codes are not generated when all other expansion cards are absent, one of the add-in cards is causing the malfunction. Insert the cards back into the system one at a time until the problem happens again. This will reveal the malfunctioning card.
8	If the system video adapter is an add-in card, replace or reseat the video adapter. If the video adapter is an integrated part of the system board, the board may be faulty.

4.5 TROUBLESHOOTING

Probable	Solution
1. No power to the system at all Power light don't illuminate, fan inside power supply does not turn on. 2. Indicator light on keyboard does not turn on.	1. Make sure power cable is securely plugged in. 2. Replace cable. 3. Contact technical support.
System inoperative. Keyboard lights are on, power indicator lights are lit, and hard drive is spinning.	Using even pressure on both ends of the DIMM, press down firmly until the module snaps into place.
System does not boot from hard disk drive, can be booted from optical drive.	1. Check cable running from disk to disk controller board. Make sure both ends are securely plugged in; check the drive type in the standard CMOS setup. 2. Backing up the hard drive is extremely important. All hard disks are capable of breaking down at any time.
System only boots from optical drive. Hard disk can be read and applications can be used but booting from hard disk is impossible.	1. Back up data and applications files. 2. Reformat the hard drive. Re-install applications and data using backup disks.
Screen message says "Invalid Configuration" or "CMOS Failure."	Review system's equipment. Make sure correct information is in setup.
Cannot boot system after installing second hard drive.	1. Set master/slave jumpers correctly. 2. Run SETUP program and select correct drive types. Call the drive manufacturers for compatibility with other drives.

APPENDIX: SPEC IN OTHER LANGUAGES

GERMAN

	<i>P45D2-A7</i>	<i>P43-A7</i>
CPU	LGA 775 Intel Core2Duo / Core2Quad / Pentium Dual-Core / Celeron Dual-Core / Celeron 4xx Prozessoren Unterstützt Execute Disable Bit / Enhanced Intel SpeedStep® / Intel Architecture-64 / Extended Memory 64 Technology / Virtualization Technology	LGA 775 Intel Core2Duo / Core2Quad / Pentium Dual-Core / Celeron Dual-Core / Celeron 4xx Prozessoren Unterstützt Execute Disable Bit / Enhanced Intel SpeedStep® / Intel Architecture-64 / Extended Memory 64 Technology / Virtualization Technology
FSB	800 / 1066 / 1333 / 1600 MHz	800 / 1066 / 1333 / 1600 MHz
Chipsatz	Intel P45 Intel ICH10	Intel P43 Intel ICH10
Super E/A	ITE 8718F Bietet die häufig verwendeten alten Super E/A-Funktionen. Low Pin Count-Schnittstelle Umgebungskontrolle, Hardware-Überwachung Lüfterdrehzahl-Controller/-Überwachung "Smart Guardian"-Funktion von ITE	ITE 8718F Bietet die häufig verwendeten alten Super E/A-Funktionen. Low Pin Count-Schnittstelle Umgebungskontrolle, Hardware-Überwachung Lüfterdrehzahl-Controller/-Überwachung "Smart Guardian"-Funktion von ITE
Arbeitsspeicher	DDR2 DIMM-Steckplätze x 4 Jeder DIMM unterstützt 256MB / 512MB / 1GB / 2GB DDR2. Max. 8GB Arbeitsspeicher Dual-Kanal DDR2 Speichermodul Unterstützt DDR2 1066 / 800 / 667 registrierte DIMMs. ECC DIMMs werden nicht unterstützt.	DDR2 DIMM-Steckplätze x 4 Jeder DIMM unterstützt 256MB / 512MB / 1GB / 2GB DDR2. Max. 8GB Arbeitsspeicher Dual-Kanal DDR2 Speichermodul Unterstützt DDR2 1066 / 800 / 667 registrierte DIMMs. ECC DIMMs werden nicht unterstützt.
IDE	JMicro JMB368 Ultra DMA 33 / 66 / 100 / 133 Bus Master-Modus Unterstützt PIO-Modus 0~4,	JMicro JMB368 Ultra DMA 33 / 66 / 100 / 133 Bus Master-Modus Unterstützt PIO-Modus 0~4,
SATA	Integrierter Serial ATA-Controller Datentransferrate bis zu 3.0Gb/s Konform mit der SATA-Spezifikation Version 2.0.	Integrierter Serial ATA-Controller Datentransferrate bis zu 3.0Gb/s Konform mit der SATA-Spezifikation Version 2.0.

P45D2-A7/P43-A7

	P45D2-A7	P43-A7
LAN	Realtek RTL 8111C 10 / 100 / 1000 Mb/s Auto-Negotiation Halb-/ Vollduplex-Funktion	Realtek RTL 8111C 10 / 100 / 1000 Mb/s Auto-Negotiation Halb-/ Vollduplex-Funktion
HD Audio-Unters tützung	ALC662 Unterstützt High-Definition Audio 5.1-Kanal-Audioausgabe	ALC662 Unterstützt High-Definition Audio 5.1-Kanal-Audioausgabe
Steckplätze	PCI-Steckplatz x3 PCI Express Gen2 x16 Steckplatz x1 PCI Express x 1-Steckplatz x2	PCI-Steckplatz x3 PCI Express Gen2 x16 Steckplatz x1 PCI Express x 1-Steckplatz x2
Onboard-Ans chluss	Diskettenlaufwerkanschluss x1 Druckeranschluss Anschluss x1 Serieller Anschluss x1 IDE-Anschluss x1 SATA-Anschluss x6 Fronttafelanschluss x1 Front-Audioanschluss x1 CD-IN-Anschluss x1 CPU-Lüfter-Sockel x1 System-Lüfter-Sockel x1 "CMOS löschen"-Sockel x1 USB-Anschluss x3 Stromanschluss (24-polig) x1 Stromanschluss (4-polig) x1	Diskettenlaufwerkanschluss x1 Druckeranschluss Anschluss x1 Serieller Anschluss x1 IDE-Anschluss x1 SATA-Anschluss x6 Fronttafelanschluss x1 Front-Audioanschluss x1 CD-IN-Anschluss x1 CPU-Lüfter-Sockel x1 System-Lüfter-Sockel x1 "CMOS löschen"-Sockel x1 USB-Anschluss x3 Stromanschluss (24-polig) x1 Stromanschluss (4-polig) x1
Rückseiten-E /A	PS/2-Tastatur x1 PS/2-Maus x1 LAN-Anschluss x1 USB-Anschluss x6 Audioanschluss x3	PS/2-Tastatur x1 PS/2-Maus x1 LAN-Anschluss x1 USB-Anschluss x6 Audioanschluss x3
Platinengröße	205 mm (B) X 305 mm (L)	205 mm (B) X 305 mm (L)
OS-Unterstüt zung	Windows 2000 / XP / VISTA Biostar behält sich das Recht vor, ohne Ankündigung die Unterstützung für ein Betriebssystem hinzuzufügen oder zu entfernen.	Windows 2000 / XP / VISTA Biostar behält sich das Recht vor, ohne Ankündigung die Unterstützung für ein Betriebssystem hinzuzufügen oder zu entfernen.

FRANCE

	P45D2-A7	P43-A7
UC	LGA 775 Processeurs Intel Core2Duo / Core2Quad / Pentium Dual-Core / Celeron Dual-Core / Celeron 4xx Prend en charge les technologies d'exécution de bit de désactivation / Intel SpeedStep® optimisée/ d'architecture Intel 64 / de mémoire étendue 64 / de virtualisation	LGA 775 Processeurs Intel Core2Duo / Core2Quad / Pentium Dual-Core / Celeron Dual-Core / Celeron 4xx Prend en charge les technologies d'exécution de bit de désactivation / Intel SpeedStep® optimisée/ d'architecture Intel 64 / de mémoire étendue 64 / de virtualisation
Bus frontal	800 / 1066 / 1333 / 1600 MHz	800 / 1066 / 1333 / 1600 MHz
Chipset	Intel P45 Intel ICH10	Intel P43 Intel ICH10
Super E/S	ITE 8718F Fournit la fonctionnalité de Super E/S patrimoniales la plus utilisée. Interface à faible compte de broches Initiatives de contrôle environnementales, Moniteur de matériel Contrôleur /moniteur de vitesse de ventilateur Fonction "Gardien intelligent" de l'ITE	ITE 8718F Fournit la fonctionnalité de Super E/S patrimoniales la plus utilisée. Interface à faible compte de broches Initiatives de contrôle environnementales, Moniteur de matériel Contrôleur /moniteur de vitesse de ventilateur Fonction "Gardien intelligent" de l'ITE
Mémoire principale	Fentes DDR2 DIMM x 4 Chaque DIMM prend en charge des DDR2 de 256Mo / 512Mo / 1Go / 2Go Capacité mémoire maximale de 8Go Module de mémoire DDR2 à mode à double voie Prend en charge la DDR2 1066 / 800 / 667 Les DIMM à registres et DIMM avec code correcteurs d'erreurs ne sont pas prises en charge	Fentes DDR2 DIMM x 4 Chaque DIMM prend en charge des DDR2 de 256Mo / 512Mo / 1Go / 2Go Capacité mémoire maximale de 8Go Module de mémoire DDR2 à mode à double voie Prend en charge la DDR2 1066 / 800 / 667 Les DIMM à registres et DIMM avec code correcteurs d'erreurs ne sont pas prises en charge
IDE	JMicro JMB368 Mode principale de Bus Ultra DMA 33 / 66 / 100 / 133 Prend en charge le mode PIO 0~4,	JMicro JMB368 Mode principale de Bus Ultra DMA 33 / 66 / 100 / 133 Prend en charge le mode PIO 0~4,
SATA	Contrôleur Serial ATA intégré : Taux de transfert jusqu'à 3.0Go/s. Conforme à la spécification SATA Version 2.0	Contrôleur Serial ATA intégré : Taux de transfert jusqu'à 3.0Go/s. Conforme à la spécification SATA Version 2.0

P45D2-A7/P43-A7

	P45D2-A7	P43-A7
LAN	Realtek RTL 8111C 10 / 100 / 1000 Mb/s négociation automatique Half / Full duplex capability	Realtek RTL 8111C 10 / 100 / 1000 Mb/s négociation automatique Half / Full duplex capability
Prise en charge audio HD	ALC662 Prise en charge de l'audio haute définition Sortie audio à 5.1 voies	ALC662 Prise en charge de l'audio haute définition Sortie audio à 5.1 voies
Fentes	Fente PCI x3 Fente PCI Express Gen2 x16 x1 Fente PCI Express x1 x2	Fente PCI x3 Fente PCI Express Gen2 x16 x1 Fente PCI Express x1 x2
Connecteur embarqué	Connecteur de disquette x1 Connecteur de Port d'imprimante x1 Port série x1 Connecteur IDE x1 Connecteur SATA x6 Connecteur du panneau avant x1 Connecteur Audio du panneau avant x1 Connecteur d'entrée CD x1 Embase de ventilateur UC x1 Embase de ventilateur système x1 Embase d'effacement CMOS x1 Connecteur USB x3 Connecteur d'alimentation x1 (24 broches) Connecteur d'alimentation x1 (4 broches)	Connecteur de disquette x1 Connecteur de Port d'imprimante x1 Port série x1 Connecteur IDE x1 Connecteur SATA x6 Connecteur du panneau avant x1 Connecteur Audio du panneau avant x1 Connecteur d'entrée CD x1 Embase de ventilateur UC x1 Embase de ventilateur système x1 Embase d'effacement CMOS x1 Connecteur USB x3 Connecteur d'alimentation x1 (24 broches) Connecteur d'alimentation x1 (4 broches)
E/S du panneau arrière	Clavier PS/2 x1 Souris PS/2 x1 Port LAN x1 Port USB x6 Fiche audio x3	Clavier PS/2 x1 Souris PS/2 x1 Port LAN x1 Port USB x6 Fiche audio x3
Dimensions de la carte	205 mm (l) X 305 mm (H)	205 mm (l) X 305 mm (H)
Support SE	Windows 2000 / XP / VISTA Biostar se réserve le droit d'ajouter ou de supprimer le support de SE avec ou sans préavis.	Windows 2000 / XP / VISTA Biostar se réserve le droit d'ajouter ou de supprimer le support de SE avec ou sans préavis.

ITALIAN

	P45D2-A7	P43-A7
CPU	LGA 775 Processore Intel Core2Duo / Core2Quad / Pentium Dual-Core / Celeron Dual-Core / Celeron 4xx Supporto di Execute Disable Bit / Enhanced Intel SpeedStep® / Architettura Intel 64 / Tecnologia Extended Memory 64 / Tecnologia Virtualization	LGA 775 Processore Intel Core2Duo / Core2Quad / Pentium Dual-Core / Celeron Dual-Core / Celeron 4xx Supporto di Execute Disable Bit / Enhanced Intel SpeedStep® / Architettura Intel 64 / Tecnologia Extended Memory 64 / Tecnologia Virtualization
FSB	800 / 1066 / 1333 / 1600 MHz	800 / 1066 / 1333 / 1600 MHz
Chipset	Intel P45 Intel ICH10	Intel P43 Intel ICH10
Super I/O	ITE 8718F Fornisce le funzionalità legacy Super I/O usate più comunemente. Interfaccia LPC (Low Pin Count) Funzioni di controllo dell'ambiente: Monitoraggio hardware Controller / Monitoraggio velocità ventolina Funzione "Smart Guardian" di ITE	ITE 8718F Fornisce le funzionalità legacy Super I/O usate più comunemente. Interfaccia LPC (Low Pin Count) Funzioni di controllo dell'ambiente: Monitoraggio hardware Controller / Monitoraggio velocità ventolina Funzione "Smart Guardian" di ITE
Memoria principale	Alloggi DIMM DDR2 x 4 Ciascun DIMM supporta DDR2 256MB / 512MB / 1GB / 2GB Capacità massima della memoria 8GB Modulo di memoria DDR2 a canale doppio Supporto di DDR2 1066 / 800 / 667 DIMM registrati e DIMM ECC non sono supportati	Alloggi DIMM DDR2 x 4 Ciascun DIMM supporta DDR2 256MB / 512MB / 1GB / 2GB Capacità massima della memoria 8GB Modulo di memoria DDR2 a canale doppio Supporto di DDR2 1066 / 800 / 667 DIMM registrati e DIMM ECC non sono supportati
IDE	JMicro JMB368 Modalità Bus Master Ultra DMA 33 / 66 / 100 / 133 Supporto modalità PIO Mode 0-4	JMicro JMB368 Modalità Bus Master Ultra DMA 33 / 66 / 100 / 133 Supporto modalità PIO Mode 0-4
SATA	Controller Serial ATA integrato Velocità di trasferimento dei dati fino a 3.0Gb/s. Compatibile specifiche SATA Versione 2.0.	Controller Serial ATA integrato Velocità di trasferimento dei dati fino a 3.0Gb/s. Compatibile specifiche SATA Versione 2.0.
LAN	Realtek RTL 8111C Negoziazione automatica 10/100/1000 Mb/s Capacità Half / Full Duplex	Realtek RTL 8111C Negoziazione automatica 10/100/1000 Mb/s Capacità Half / Full Duplex

P45D2-A7/P43-A7

	P45D2-A7	P43-A7
Supporto audio HD	ALC662 Supporto audio High-Definition (HD) Uscita audio 5.1 canali	ALC662 Supporto audio High-Definition (HD) Uscita audio 5.1 canali
Alloggi	Alloggio PCI x3 Alloggio PCI Express Gen2 x16 x1 Alloggio PCI Express x1 x2	Alloggio PCI x3 Alloggio PCI Express Gen2 x16 x1 Alloggio PCI Express x1 x2
Connettori su scheda	Connettore floppy x1 Connettore Porta stampante x1 Porta seriale x1 Connettore IDE x1 Connettore SATA x6 Connettore pannello frontale x1 Connettore audio frontale x1 Connettore CD-in x1 Collettore ventolina CPU x1 Collettore ventolina sistema x1 Collettore cancellazione CMOS x1 Connettore USB x3 Connettore alimentazione (24 pin) x1 Connettore alimentazione (4 pin) x1	Connettore floppy x1 Connettore Porta stampante x1 Porta seriale x1 Connettore IDE x1 Connettore SATA x6 Connettore pannello frontale x1 Connettore audio frontale x1 Connettore CD-in x1 Collettore ventolina CPU x1 Collettore ventolina sistema x1 Collettore cancellazione CMOS x1 Connettore USB x3 Connettore alimentazione (24 pin) x1 Connettore alimentazione (4 pin) x1
I/O pannello posteriore	Tastiera PS/2 x1 Mouse PS/2 x1 Porta LAN x1 Porta USB x6 Connettore audio x3	Tastiera PS/2 x1 Mouse PS/2 x1 Porta LAN x1 Porta USB x6 Connettore audio x3
Dimensioni scheda	205 mm (larghezza) x 305 mm (altezza)	205 mm (larghezza) x 305 mm (altezza)
Sistemi operativi supportati	Windows 2000 / XP / VISTA Biostar si riserva il diritto di aggiungere o rimuovere il supporto di qualsiasi sistema operativo senza preavviso.	Windows 2000 / XP / VISTA Biostar si riserva il diritto di aggiungere o rimuovere il supporto di qualsiasi sistema operativo senza preavviso.

SPANISH

	P45D2-A7	P43-A7
CPU	LGA 775 Procesador Intel Core2Duo / Core2Quad / Pentium Dual-Core / Celeron Dual-Core / Celeron 4xx Admite Bit de deshabilitación de ejecución / Intel SpeedStep® Mejorado / Intel Architecture-64 / Tecnología Extended Memory 64 / Tecnología de virtualización	LGA 775 Procesador Intel Core2Duo / Core2Quad / Pentium Dual-Core / Celeron Dual-Core / Celeron 4xx Admite Bit de deshabilitación de ejecución / Intel SpeedStep® Mejorado / Intel Architecture-64 / Tecnología Extended Memory 64 / Tecnología de virtualización
FSB	800 / 1066 / 1333 / 1600 MHz	800 / 1066 / 1333 / 1600 MHz
Conjunto de chips	Intel P45 Intel ICH10	Intel P43 Intel ICH10
Súper E/S	ITE 8718F Le ofrece las funcionalidades heredadas de uso más común Súper E/S. Interfaz de cuenta Low Pin Iniciativas de control de entorno, Monitor hardware Controlador/monitor de velocidad de ventilador Función "Guardia inteligente" de ITE	ITE 8718F Le ofrece las funcionalidades heredadas de uso más común Súper E/S. Interfaz de cuenta Low Pin Iniciativas de control de entorno, Monitor hardware Controlador/monitor de velocidad de ventilador Función "Guardia inteligente" de ITE
Memoria principal	Ranuras DIMM DDR2 x 4 Cada DIMM admite DDR de 256MB / 512MB / 1GB / 2GB Capacidad máxima de memoria de 8GB Módulo de memoria DDR2 de canal Doble Admite DDR2 de 1066 / 800 / 667 No admite DIMM registrados o DIMM compatibles con ECC	Ranuras DIMM DDR2 x 4 Cada DIMM admite DDR de 256MB / 512MB / 1GB / 2GB Capacidad máxima de memoria de 8GB Módulo de memoria DDR2 de canal Doble Admite DDR2 de 1066 / 800 / 667 No admite DIMM registrados o DIMM compatibles con ECC
IDE	JMicro JMB368 Modo bus maestro Ultra DMA 33 / 66 / 100 / 133 Soporte los Modos PIO 0~4,	JMicro JMB368 Modo bus maestro Ultra DMA 33 / 66 / 100 / 133 Soporte los Modos PIO 0~4,
SATA	Controlador ATA Serie Integrado Tasas de transferencia de hasta 3.0 Gb/s. Compatible con la versión SATA 2.0.	Controlador ATA Serie Integrado Tasas de transferencia de hasta 3.0 Gb/s. Compatible con la versión SATA 2.0.
Red Local	Realtek RTL 8111C Negociación de 10 / 100 / 1000 Mb/s Funciones Half / Full dúplex	Realtek RTL 8111C Negociación de 10 / 100 / 1000 Mb/s Funciones Half / Full dúplex

P45D2-A7/P43-A7

	P45D2-A7		P43-A7	
Soporte de sonido HD	ALC662 Soporte de sonido de Alta Definición Salida de sonido de 5.1 canales		ALC662 Soporte de sonido de Alta Definición Salida de sonido de 5.1 canales	
Ranuras	Ranura PCI X3 Ranura PCI Express Gen2 x16 X1 Ranura PCI express x 1 X2		Ranura PCI X3 Ranura PCI Express Gen2 x16 X1 Ranura PCI express x 1 X2	
Conectores en placa	Conector disco flexible X1 Conector Puerto de impresora X1 Puerto serie X1 Conector IDE X1 Conector SATA X6 Conector de panel frontal X1 Conector de sonido frontal X1 Conector de entrada de CD X1 Cabecera de ventilador de CPU X1 Cabecera de ventilador de sistema X1 Cabecera de borrado de CMOS X1 Conector USB X3 Conector de alimentación X1 (24 patillas) Conector de alimentación X1 (4 patillas)		Conector disco flexible X1 Conector Puerto de impresora X1 Puerto serie X1 Conector IDE X1 Conector SATA X6 Conector de panel frontal X1 Conector de sonido frontal X1 Conector de entrada de CD X1 Cabecera de ventilador de CPU X1 Cabecera de ventilador de sistema X1 Cabecera de borrado de CMOS X1 Conector USB X3 Conector de alimentación X1 (24 patillas) Conector de alimentación X1 (4 patillas)	
Panel trasero de E/S	Teclado PS/2 X1 Ratón PS/2 X1 Puerto de red local X1 Puerto USB X6 Conector de sonido X3		Teclado PS/2 X1 Ratón PS/2 X1 Puerto de red local X1 Puerto USB X6 Conector de sonido X3	
Tamaño de la placa	205 mm. (A) X 305 Mm. (H)		205 mm. (A) X 305 Mm. (H)	
Soporte de sistema operativo	Windows 2000 / XP / VISTA Biostar se reserva el derecho de añadir o retirar el soporte de cualquier SO con o sin aviso previo.		Windows 2000 / XP / VISTA Biostar se reserva el derecho de añadir o retirar el soporte de cualquier SO con o sin aviso previo.	

PORTUGUESE

	P45D2-A7	P43-A7
CPU	LGA 775 Processador Intel Core2Duo / Core2Quad / Pentium Dual-Core / Celeron Dual-Core / Celeron 4xx Suporta as tecnologias Execute Disable Bit / Enhanced Intel SpeedStep® / Intel Architecture -64 / Extended Memory 64 / Virtualization	LGA 775 Processador Intel Core2Duo / Core2Quad / Pentium Dual-Core / Celeron Dual-Core / Celeron 4xx Suporta as tecnologias Execute Disable Bit / Enhanced Intel SpeedStep® / Intel Architecture -64 / Extended Memory 64 / Virtualization
FSB	800 / 1066 / 1333 / 1600 MHz	800 / 1066 / 1333 / 1600 MHz
Chipset	Intel P45 Intel ICH10	Intel P43 Intel ICH10
Especificação do Super I/O	ITE 8718F Proporciona as funcionalidades mais utilizadas em termos da especificação Super I/O. Interface LPC (Low Pin Count). Iniciativas para controlo do ambiente Monitorização do hardware Controlador/Monitor da velocidade da ventoinha Função "Smart Guardian" da ITE	ITE 8718F Proporciona as funcionalidades mais utilizadas em termos da especificação Super I/O. Interface LPC (Low Pin Count). Iniciativas para controlo do ambiente Monitorização do hardware Controlador/Monitor da velocidade da ventoinha Função "Smart Guardian" da ITE
Memória principal	Ranuras DIMM DDR2 x 4 Cada módulo DIMM suporta uma memória DDR2 de 256 MB / 512 MB / 1GB / 2GB Capacidade máxima de memória:8 GB Módulo de memória DDR2 de canal duplo Suporta módulos DDR2 1066 / 800 / 667 Os módulos DIMM registados e os DIMM ECC não são suportados	Ranuras DIMM DDR2 x 4 Cada módulo DIMM suporta uma memória DDR2 de 256 MB / 512 MB / 1GB / 2GB Capacidade máxima de memória:8 GB Módulo de memória DDR2 de canal duplo Suporta módulos DDR2 1066 / 800 / 667 Os módulos DIMM registados e os DIMM ECC não são suportados
IDE	JMicro JMB368 Modo Bus master Ultra DMA 33 / 66 / 100 / 133 Suporta o modo PIO 0~4,	JMicro JMB368 Modo Bus master Ultra DMA 33 / 66 / 100 / 133 Suporta o modo PIO 0~4,
SATA	Controlador Serial ATA integrado Velocidades de transmissão de dados até 3.0 Gb/s. Compatibilidade com a especificação SATA versão 2.0.	Controlador Serial ATA integrado Velocidades de transmissão de dados até 3.0 Gb/s. Compatibilidade com a especificação SATA versão 2.0.
LAN	Realtek RTL 8111C Auto negociação de 10 / 100 / 1000 Mb/s Capacidade semi/full-duplex	Realtek RTL 8111C Auto negociação de 10 / 100 / 1000 Mb/s Capacidade semi/full-duplex

P45D2-A7/P43-A7

	P45D2-A7		P43-A7	
Suporte para áudio de alta definição	ALC662 Suporta a especificação High-Definition Audio Saída de áudio de 5.1 canais		ALC662 Suporta a especificação High-Definition Audio Saída de áudio de 5.1 canais	
Ranhuras	Ranhura PCI	x3	Ranhura PCI	x3
	Ranhura PCI Express Gen2 x16	x1	Ranhura PCI Express Gen2 x16	x1
	Ranhura PCI Express x 1	x2	Ranhura PCI Express x 1	x2
Conectores na placa	Conector da unidade de disquetes	x1	Conector da unidade de disquetes	x1
	Conector da para impressora	x1	Conector da para impressora	x1
	Porta série	x1	Porta série	x1
	Conector IDE	x1	Conector IDE	x1
	Conector SATA	x6	Conector SATA	x6
	Conector do painel frontal	x1	Conector do painel frontal	x1
	Conector de áudio frontal	x1	Conector de áudio frontal	x1
	Conector para entrada de CDs	x1	Conector para entrada de CDs	x1
	Conector da ventoinha da CPU	x1	Conector da ventoinha da CPU	x1
	Conector da ventoinha do sistema	x1	Conector da ventoinha do sistema	x1
	Conector para limpeza do CMOS	x1	Conector para limpeza do CMOS	x1
	Conector USB	x3	Conector USB	x3
	Conector de alimentação (24 pinos)	x1	Conector de alimentação (24 pinos)	x1
	Conector de alimentação (4 pinos)	x1	Conector de alimentação (4 pinos)	x1
Entradas/Saídas no painel traseiro	Teclado PS/2	x1	Teclado PS/2	x1
	Rato PS/2	x1	Rato PS/2	x1
	Porta LAN	x1	Porta LAN	x1
	Porta USB	x6	Porta USB	x6
	Tomada de áudio	x3	Tomada de áudio	x3
Tamanho da placa	205 mm (L) X 305 mm (A)		205 mm (L) X 305 mm (A)	
Sistemas operativos suportados	Windows 2000 / XP / VISTA A Biostar reserva-se o direito de adicionar ou remover suporte para qualquer sistema operativo com ou sem aviso prévio.		Windows 2000 / XP / VISTA A Biostar reserva-se o direito de adicionar ou remover suporte para qualquer sistema operativo com ou sem aviso prévio.	

POLISH

	P45D2-A7	P43-A7
Procesor	LGA 775 Procesor Intel Core2Duo / Core2Quad / Pentium Dual-Core / Celeron Dual-Core / Celeron 4xx Obsługa Execute Disable Bit / Enhanced Intel SpeedStep® / Intel Architecture-64 / Extended Memory 64 Technology / Virtualization Technology	LGA 775 Procesor Intel Core2Duo / Core2Quad / Pentium Dual-Core / Celeron Dual-Core / Celeron 4xx Obsługa Execute Disable Bit / Enhanced Intel SpeedStep® / Intel Architecture-64 / Extended Memory 64 Technology / Virtualization Technology
FSB	800 / 1066 / 1333 / 1600 MHz	800 / 1066 / 1333 / 1600 MHz
Chipset	Intel P45 Intel ICH10	Intel P43 Intel ICH10
Pamięć główna	Gniazda DDR2 DIMM x 4 Każde gniazdo DIMM obsługuje moduły 256MB / 512MB / 1GB / 2GB Maks. wielkość pamięci 8GB Moduł pamięci DDR2 z trybem podwójnego kanału Obsługa DDR2 1066 / 800 / 667 Brak obsługi Registered DIMM oraz ECC DIMM	Gniazda DDR2 DIMM x 4 Każde gniazdo DIMM obsługuje moduły 256MB / 512MB / 1GB / 2GB Maks. wielkość pamięci 8GB Moduł pamięci DDR2 z trybem podwójnego kanału Obsługa DDR2 1066 / 800 / 667 Brak obsługi Registered DIMM oraz ECC DIMM
Super I/O	ITE 8718F Zapewnia najbardziej powszechne funkcje Super I/O. Interfejs Low Pin Count Funkcje kontroli warunków pracy, Monitor H/W Kontroler/Monitor prędkości wentylatora Funkcja ITE "Smart Guardian"	ITE 8718F Zapewnia najbardziej powszechne funkcje Super I/O. Interfejs Low Pin Count Funkcje kontroli warunków pracy, Monitor H/W Kontroler/Monitor prędkości wentylatora Funkcja ITE "Smart Guardian"
IDE	JMicro JMB368 Ultra DMA 33 / 66 / 100 / 133 Tryb Bus Master obsługa PIO tryb 0~4,	JMicro JMB368 Ultra DMA 33 / 66 / 100 / 133 Tryb Bus Master obsługa PIO tryb 0~4,
SATA	Zintegrowany kontroler Serial ATA Transfer danych do 3.0 Gb/s. Zgodność ze specyfikacją SATA w wersji 2.0.	Zintegrowany kontroler Serial ATA Transfer danych do 3.0 Gb/s. Zgodność ze specyfikacją SATA w wersji 2.0.
LAN	Realtek RTL 8111C 10 / 100 / 1000 Mb/s z automatyczną negocjacją szybkości Działanie w trybie półowicznego / pełnego dupleksu	Realtek RTL 8111C 10 / 100 / 1000 Mb/s z automatyczną negocjacją szybkości Działanie w trybie półowicznego / pełnego dupleksu

P45D2-A7/P43-A7

	P45D2-A7	P43-A7
Obsługa audio HD	ALC662 Obsługa High-Definition Audio 5.1 kanałowe wyjście audio	ALC662 Obsługa High-Definition Audio 5.1 kanałowe wyjście audio
Gniazda	Gniazdo PCI x3 Gniazdo PCI Express Gen2 x16 x1 Gniazdo PCI Express x 1 x2	Gniazdo PCI x3 Gniazdo PCI Express Gen2 x16 x1 Gniazdo PCI Express x 1 x2
Złącza wbudowane	Złącze napędu dyskietek x1 Złącze Port drukarki x1 Port szeregowy x1 Złącze IDE x1 Złącze SATA x6 Złącze panela przedniego x1 Przednie złącze audio x1 Złącze wejścia CD x1 Złącze główkowe wentylatora procesora x1 Złącze główkowe wentylatora systemowego x1 Złącze główkowe kasowania CMOS x1 Złącze USB x3 Złącze zasilania (24 pinowe) x1 Złącze zasilania (4 pinowe) x1	Złącze napędu dyskietek x1 Złącze Port drukarki x1 Port szeregowy x1 Złącze IDE x1 Złącze SATA x6 Złącze panela przedniego x1 Przednie złącze audio x1 Złącze wejścia CD x1 Złącze główkowe wentylatora procesora x1 Złącze główkowe wentylatora systemowego x1 Złącze główkowe kasowania CMOS x1 Złącze USB x3 Złącze zasilania (24 pinowe) x1 Złącze zasilania (4 pinowe) x1
Back Panel I/O	Klawiatura PS/2 x1 Mysz PS/2 x1 Port LAN x1 Port USB x6 Gniazdo audio x3	Klawiatura PS/2 x1 Mysz PS/2 x1 Port LAN x1 Port USB x6 Gniazdo audio x3
Wymiary płyty	205 mm (S) X 305 mm (W)	205 mm (S) X 305 mm (W)
Obsługa systemu operacyjnego	Windows 2000 / XP / VISTA Biostar zastrzega sobie prawo dodawania lub odwoływania obsługi dowolnego systemu operacyjnego bez powiadomienia.	Windows 2000 / XP / VISTA Biostar zastrzega sobie prawo dodawania lub odwoływania obsługi dowolnego systemu operacyjnego bez powiadomienia.

RUSSIAN

	P45D2-A7	P43-A7
CPU (центральный процессор)	LGA 775 Процессор Intel Core2Duo / Core2Quad / Pentium Dual-Core / Celeron Dual-Core / Celeron 4xx Поддержка технологий Execute Disable Bit / Enhanced Intel SpeedStep® / Intel Architecture-64 / Extended Memory 64 Technology / технологии виртуализация	LGA 775 Процессор Intel Core2Duo / Core2Quad / Pentium Dual-Core / Celeron Dual-Core / Celeron 4xx Поддержка технологий Execute Disable Bit / Enhanced Intel SpeedStep® / Intel Architecture-64 / Extended Memory 64 Technology / технологии виртуализация
FSB	800 / 1066 / 1333 / 1600 МГц	800 / 1066 / 1333 / 1600 МГц
Набор микросхем	Intel P45 Intel ICH10	Intel P43 Intel ICH10
Основная память	Слоты DDR2 DIMM x 4 Каждый модуль DIMM поддерживает 256 МБ / 512МБ / 1ГБ / 2ГБ DDR2 Максимальная ёмкость памяти 8ГБ Модуль памяти с двухканальным режимом DDR2 Поддержка DDR2 1066 / 800 / 667 Не поддерживает зарегистрированные модули DIMM and ECC DIMM	Слоты DDR2 DIMM x 4 Каждый модуль DIMM поддерживает 256 МБ / 512МБ / 1ГБ / 2ГБ DDR2 Максимальная ёмкость памяти 8ГБ Модуль памяти с двухканальным режимом DDR2 Поддержка DDR2 1066 / 800 / 667 Не поддерживает зарегистрированные модули DIMM and ECC DIMM
Super I/O	ITE 8718F Обеспечивает наиболее используемые действующие функциональные возможности Super I/O. Интерфейс с низким количеством выводов Инициативы по охране окружающей среды, Аппаратный монитор Регулятор скорости вентилятора/ монитор Функция ITE "Smart Guardian" (Интеллектуальная защита)	ITE 8718F Обеспечивает наиболее используемые действующие функциональные возможности Super I/O. Интерфейс с низким количеством выводов Инициативы по охране окружающей среды, Аппаратный монитор Регулятор скорости вентилятора/ монитор Функция ITE "Smart Guardian" (Интеллектуальная защита)
IDE	JMicro JMB368 Режим "хозяина" шины Ultra DMA 33 / 66 / 100 / 133 Поддержка режима PIO 0~4,	JMicro JMB368 Режим "хозяина" шины Ultra DMA 33 / 66 / 100 / 133 Поддержка режима PIO 0~4,
SATA	Встроенное последовательное устройство управления ATA скорость передачи данных до 3.0 гигабит/с. Соответствие спецификации SATA версия 2.0.	Встроенное последовательное устройство управления ATA скорость передачи данных до 3.0 гигабит/с. Соответствие спецификации SATA версия 2.0.
Локальная сеть	Realtek RTL 8111C Автоматическое согласование 10/100/1000 Мб/с Частичная / полная дуплексная способность	Realtek RTL 8111C Автоматическое согласование 10/100/1000 Мб/с Частичная / полная дуплексная способность

P45D2-A7/P43-A7

	P45D2-A7		P43-A7	
Звуковая поддержка жесткого диска	ALC662 Звуковая поддержка High-Definition 5.1канальный звуковой выход		ALC662 Звуковая поддержка High-Definition 5.1канальный звуковой выход	
Слоты	Слот PCI	x3	Слот PCI	x3
	Слот PCI Express Gen2 x16	x1	Слот PCI Express Gen2 x16	x1
	Слот PCI Express x 1	x2	Слот PCI Express x 1	x2
Встроенный разъем	Разъем НГМД	x1	Разъем НГМД	x1
	Разъем Порт подключения принтера	x1	Разъем Порт подключения принтера	x1
	Последовательный порт	x1	Последовательный порт	x1
	Разъем IDE	x1	Разъем IDE	x1
	Разъем SATA	x6	Разъем SATA	x6
	Разъем на лицевой панели	x1	Разъем на лицевой панели	x1
	Входной звуковой разъем	x1	Входной звуковой разъем	x1
	Разъем ввода для CD	x1	Разъем ввода для CD	x1
	Контактирующее приспособление вентилятора центрального процессора	x1	Контактирующее приспособление вентилятора центрального процессора	x1
	Контактирующее приспособление вентилятора системы	x1	Контактирующее приспособление вентилятора системы	x1
	Открытое контактирующее приспособление CMOS	x1	Открытое контактирующее приспособление CMOS	x1
	USB-разъем	x3	USB-разъем	x3
	Разъем питания (24 вывод)	x1	Разъем питания (24 вывод)	x1
Разъем питания (4 вывод)	x1	Разъем питания (4 вывод)	x1	
Задняя панель средств ввода-вывода	Клавиатура PS/2	x1	Клавиатура PS/2	x1
	Мышь PS/2	x1	Мышь PS/2	x1
	Порт LAN	x1	Порт LAN	x1
	USB-порт	x6	USB-порт	x6
	Гнездо для подключения наушников	x3	Гнездо для подключения наушников	x3
Размер панели	205 мм (Ш) X 305 мм (В)		205 мм (Ш) X 305 мм (В)	
Поддержка OS	Windows 2000 / XP / VISTA Biostar сохраняет за собой право добавлять или удалять средства обеспечения для OS с или без предварительного уведомления.		Windows 2000 / XP / VISTA Biostar сохраняет за собой право добавлять или удалять средства обеспечения для OS с или без предварительного уведомления.	

ARABIC

P43-A7	P45D2-A7	
LGA 775 Intel Core2Duo / Core2Quad / Pentium Dual-Core / Celeron Dual-Core / Celeron 4xx تبردد يصل إلى Execute Disable Bit / Enhanced Intel SpeedStep® / Intel Architecture-64 / Extended Memory 64 Technology / Virtualization Technology	LGA 775 Intel Core2Duo / Core2Quad / Pentium Dual-Core / Celeron Dual-Core / Celeron 4xx تبردد يصل إلى Execute Disable Bit / Enhanced Intel SpeedStep® / Intel Architecture-64 / Extended Memory 64 Technology / Virtualization Technology	وحدة المعالجة المركزية
ميجا هرتز 800 / 1066 / 1333 / 1600 تردد	ميجا هرتز 800 / 1066 / 1333 / 1600 تردد	النقل الأممي الجانبي
Intel P43 Intel ICH10	Intel P45 Intel ICH10	مجموعة الشرائح
عدد4 قناة DDR2 DIMM ميجا 256/512 سعة DDR2 تدعم ذاكرة من نوع DIMM كل قناة بليت 2 و بليت 1 جيجا بليت سعة ذاكرة قصوى 8 جيجا بليت مزودة لقناة DDR2 وحدة ذاكرة سعت 1066 / 800 / 667 ميجا بليت DDR2 تدعم الذاكرة من نوع ECC وتلك التي لا تتوافق مع DIMM لا تدعم رقائق الذاكرة	عدد4 قناة DDR2 DIMM ميجا 256/512 سعة DDR2 تدعم ذاكرة من نوع DIMM كل قناة بليت 2 و بليت 1 جيجا بليت سعة ذاكرة قصوى 8 جيجا بليت مزودة لقناة DDR2 وحدة ذاكرة سعت 1066 / 800 / 667 ميجا بليت DDR2 تدعم الذاكرة من نوع ECC وتلك التي لا تتوافق مع DIMM لا تدعم رقائق الذاكرة	الذاكرة الرئيسية
ITE 8718F الأكثر استخداماً. Super I/O يوفر وظيفة Low Pin Count Interface تدعم تقنية وسائل التحكم في البيئة: مراقب لمعرفة حالة الأجهزة مراقب في سرعة المروحة ITE من "Smart Guardian" ووظيفة	ITE 8718F الأكثر استخداماً. Super I/O يوفر وظيفة Low Pin Count Interface تدعم تقنية وسائل التحكم في البيئة: مراقب لمعرفة حالة الأجهزة مراقب في سرعة المروحة ITE من "Smart Guardian" ووظيفة	Super I/O
JMicro JMB368 متحكم IDE وضع رئيسي Ultra DMA 33 / 66 / 100 / 133 نقل بتقنية PIO Mode 0 ~4 دعم وضع	JMicro JMB368 متحكم IDE وضع رئيسي Ultra DMA 33 / 66 / 100 / 133 نقل بتقنية PIO Mode 0 ~4 دعم وضع	منفذ IDE
متكامل Serial ATA متحكم جيجابت/ثانية 3.0 نقل البيانات بسرعة تصل إلى 2.0 الإصدار SATA مطابقة لمواصفات	متكامل Serial ATA متحكم جيجابت/ثانية 3.0 نقل البيانات بسرعة تصل إلى 2.0 الإصدار SATA مطابقة لمواصفات	SATA
Realtek RTL 8111C تفاوض تلقائي 1000/100/10 ميجا بليت / ثانية إمكانية النقل المزدوج الكامل/النصفي	Realtek RTL 8111C تفاوض تلقائي 1000/100/10 ميجا بليت / ثانية إمكانية النقل المزدوج الكامل/النصفي	شبكة داخلية

P45D2-A7/P43-A7

P43-A7		P45D2-A7		
	ALC662 Intel دعم تقنية الصوت عالي التعريف من 5.1 قنوات لخرج الصوت		ALC662 تدعم تقنية الصوت عالي التعريف من 5.1 قنوات لخرج الصوت	دعم الصوت عالي التعريف
عدد 3	قناة PCI	عدد 3	قناة PCI	التحات
عدد 1	قناة PCI Express x16 Gen2	عدد 1	قناة PCI Express x16 Gen2	
عدد 2	قناة PCI Express x1	عدد 2	قناة PCI Express x1	
عدد 1	منفذ محرك أقراص مرنة	عدد 1	منفذ محرك أقراص مرنة	المنفذ على سطح اللوحة
عدد 1	منفذ طباعة	عدد 1	منفذ طباعة	
عدد 1	منفذ تسلسلي	عدد 1	منفذ تسلسلي	
عدد 1	منفذ IDE	عدد 1	منفذ IDE	
عدد 6	منفذ SATA	عدد 6	منفذ SATA	
عدد 1	منفذ اللوحة الأممية	عدد 1	منفذ اللوحة الأممية	
عدد 1	منفذ الصوت الأممي	عدد 1	منفذ الصوت الأممي	
عدد 1	منفذ CD-IN	عدد 1	منفذ CD-IN	
عدد 1	وصلة مروحة وحدة المعالجة المركزية	عدد 1	وصلة مروحة وحدة المعالجة المركزية	
عدد 1	وصلة مروحة النظام	عدد 1	وصلة مروحة النظام	
عدد 1	وصلة مسح CMOS	عدد 1	وصلة مسح CMOS	
عدد 3	منفذ USB	عدد 3	منفذ USB	
عدد 1	منفذ توصيل الطاقة (24 دبوس)	عدد 1	منفذ توصيل الطاقة (24 دبوس)	
عدد 1	منفذ توصيل الطاقة (4 دبوس)	عدد 1	منفذ توصيل الطاقة (4 دبوس)	
عدد 1	لوحة مفاتيح PS/2	عدد 1	لوحة مفاتيح PS/2	منفذ دخل/خرج اللوحة الخلفية
عدد 1	ملوس PS/2	عدد 1	ملوس PS/2	
عدد 1	منفذ شبكة اتصال محلية	عدد 1	منفذ شبكة اتصال محلية	
عدد 6	منافذ USB	عدد 6	منافذ USB	
عدد 3	مقيس صوت	عدد 3	مقيس صوت	
	205 مم (عرض) X 305 مم (ارتفاع)		205 مم (عرض) X 305 مم (ارتفاع)	حجم اللوحة
	Windows 2000 / XP / VISTA بحقها في اضافة أو ازالة الدعم لأي نظام تشغيل بإخطار Biostar تحتفظ أو بدون إخطار .		Windows 2000 / XP / VISTA بحقها في اضافة أو ازالة الدعم لأي نظام تشغيل بإخطار Biostar تحتفظ أو بدون إخطار .	دعم أنظمة التشغيل

JAPANESE

	P45D2-A7	P43-A7
CPU	LGA 775 Intel Core2Duo / Core2Quad / Pentium Dual-Core / Celeron Dual-Core / Celeron 4xx processor Execute Disable Bit / Enhanced Intel SpeedStep® / Intel Architecture-64 / Extended Memory 64 Technology / Virtualization Technologyをサポートします	LGA 775 Intel Core2Duo / Core2Quad / Pentium Dual-Core / Celeron Dual-Core / Celeron 4xx processor Execute Disable Bit / Enhanced Intel SpeedStep® / Intel Architecture-64 / Extended Memory 64 Technology / Virtualization Technologyをサポートします
FSB	800 / 1066 / 1333 / 1600 MHz	800 / 1066 / 1333 / 1600 MHz
チップセット	Intel P45 Intel ICH10	Intel P43 Intel ICH10
メインメモリ	DDR2 DIMMスロット x 4 各DIMMは 256MB / 512MB / 1GB / 2GB DDR2を サポート 最大メモリ容量8GB デュアルチャンネルモードDDR2メモリモジュール DDR2 1066 / 800 / 667をサポート 登録済みDIMMとECC DIMMはサポートされません	DDR2 DIMMスロット x 4 各DIMMは 256MB / 512MB / 1GB / 2GB DDR2を サポート 最大メモリ容量8GB デュアルチャンネルモードDDR2メモリモジュール DDR2 1066 / 800 / 667をサポート 登録済みDIMMとECC DIMMはサポートされません
Super I/O	ITE 8718F もっとも一般に使用されるレガシーSuper I/O機能を 採用しています。 低ピンカウントインターフェイス 環境コントロールイニシアチブ、 H/W モニター ファン速度コントローラ/ モニター ITEの「スマートガーディアン」機能	ITE 8718F もっとも一般に使用されるレガシーSuper I/O機能を 採用しています。 低ピンカウントインターフェイス 環境コントロールイニシアチブ、 H/W モニター ファン速度コントローラ/ モニター ITEの「スマートガーディアン」機能
IDE	JMicro JMB368 Ultra DMA 33 / 66 / 100 / 133バスマスタモード PIO Mode 0~4のサポート、	JMicro JMB368 Ultra DMA 33 / 66 / 100 / 133バスマスタモード PIO Mode 0~4のサポート、
SATA	統合シリアルATAコントローラ 最高3.0 Gb/秒のデータ転送速度 SATAバージョン2.0仕様に準拠。	統合シリアルATAコントローラ 最高3.0 Gb/秒のデータ転送速度 SATAバージョン2.0仕様に準拠。
LAN	Realtek RTL 8111C 10 / 100 / 1000 Mb/秒のオートネゴシエーション 半/全二重機能	Realtek RTL 8111C 10 / 100 / 1000 Mb/秒のオートネゴシエーション 半/全二重機能

P45D2-A7/P43-A7

	P45D2-A7		P43-A7	
HDオーディオのサポート	ALC662 ハイデフィニションオーディオのサポート 5.1 チャンネルオーディオアウト		ALC662 ハイデフィニションオーディオのサポート 5.1 チャンネルオーディオアウト	
スロット	PCIスロット	x3	PCIスロット	x3
	PCI Express x16 Gen2スロット	x1	PCI Express x16 Gen2スロット	x1
	PCI Express x 1スロット	x2	PCI Express x 1スロット	x2
オンボードコネクタ	フロッピーコネクタ	x1	フロッピーコネクタ	x1
	プリンタポートコネクタ	x1	プリンタポートコネクタ	x1
	シリアルポート	x1	シリアルポート	x1
	IDEコネクタ	x1	IDEコネクタ	x1
	SATAコネクタ	x6	SATAコネクタ	x6
	フロントパネルコネクタ	x1	フロントパネルコネクタ	x1
	フロントオーディオコネクタ	x1	フロントオーディオコネクタ	x1
	CDインコネクタ	x1	CDインコネクタ	x1
	CPUファンヘッダ	x1	CPUファンヘッダ	x1
	システムファンヘッダ	x1	システムファンヘッダ	x1
	CMOSクリアヘッダ	x1	CMOSクリアヘッダ	x1
	USBコネクタ	x3	USBコネクタ	x3
電源コネクタ(24ピン)	x1	電源コネクタ(24ピン)	x1	
電源コネクタ(4ピン)	x1	電源コネクタ(4ピン)	x1	
背面パネル I/O	PS/2キーボード	x1	PS/2キーボード	x1
	PS/2マウス	x1	PS/2マウス	x1
	LANポート	x1	LANポート	x1
	USBポート	x6	USBポート	x6
	オーディオジャック	x3	オーディオジャック	x3
ボードサイズ	205 mm (幅) X 305 mm (高さ)		205 mm (幅) X 305 mm (高さ)	
OSサポート	Windows 2000 / XP / VISTA Biostarは事前のサポートなしにOSサポートを追加または削除する権利を留保します。		Windows 2000 / XP / VISTA Biostarは事前のサポートなしにOSサポートを追加または削除する権利を留保します。	

2008/07/03