



Disposal Instruction (US)

For better protection of our earth, please don't throw this electronic device into municipal trash bin when discarding. To minimize pollution and ensure utmost protection of the global environment, please recycle the product. For more information about the collection and recycling of Waste Electrical and Electronic Equipment (WEEE), you are invited to visit our homepage at www.aopen.com under "Green Products"

廃棄上の指示

より良い地球保護のために、電子機器を廃棄処分にする時は、ゴミ箱に捨てないで下さい。汚染を最小限に抑え、地球環境の最大限の保護のために、製品をリサイクルして下さい。廃電気電子機器（WEEE）の回収とリサイクルについての情報は、弊社ホームページwww.aopen.comの“Green Products”（環境に優しい製品）をご覧ください。

廢棄及回收處理

為了保護環境，請勿將本產品當作一般廢棄物處理。為減少環境污染，維護地球資源，本產品報廢時，請回收本產品。

Instruktion til bortskaffelse (Danish)

Af hensyn til vores miljø bedes De ikke bortskaffe denne elektroniske enhed i en almindelig affaldsspand. For at mindske forurening og sikre beskyttelse af miljøet bedes De genbruge produktet. For yderligere information vedrørende indsamling og genbrug af elektronik-affald (Waste Electrical and Electronic Equipment (WEEE)) er De velkommen til at besøge vores website www.aopen.com og læse nærmere under "Green Products".

Verwijderingsinstructie (Dutch)

Om mogelijke schade aan het milieu of de menselijke gezondheid door ongecontroleerde afvalverwijdering te voorkomen, moet u dit elektronisch product scheiden van andere soorten afval en op een verantwoorde manier recyclen. Verwijder dit product dan ook alstublieft niet samen met ander huishoudelijk afval. Voor meer informatie over de verzameling en recycling van elektrisch afval en elektronische apparatuur (WEEE), nodigen we u uit om onze homepage te bezoeken www.aopen.com onder "Green Products".

Instruction de Disposition (French)

Pour une meilleure protection de la terre, ne jetez pas ce dispositif électronique dans la poubelle municipale lors de la disposition. Pour éliminer la pollution et assurer la plus grande protection de l'environnement global, réutilisez s'il vous plaît le produit. Pour plus d'informations sur la gestion des déchets d'Equipements Electriques et Electroniques (DEEE ou WEEE), vous êtes invité à visiter notre site à www.aopen.com sous " Green Products".

Entsorgungsanleitung (German)

Zum besseren Schutze unseres Planeten, schmeissen Sie elektrische Geräte bitte nicht in öffentliche Mülleimer. Zur Verringerung der Verschmutzung und zur Sicherstellung grösstmöglichen Schutzes der Umwelt recyceln Sie bitte das Produkt. Für mehr Informationen zum Sammeln und Recyceln von elektrischen und elektronischen Müll (WEEE) besuchen Sie bitte unsere Homepage unter www.aopen.com unter dem Punkt "Green Products".

Istruzioni per lo smaltimento (Italian)

Per una migliore salvaguardia del nostro pianeta, si prega di non gettare questo dispositivo elettronico nei normali rifiuti al momento dell'eliminazione. Per ridurre al minimo l'inquinamento ed assicurare la massima protezione dell'ambiente, si prega di riciclare il prodotto. Per maggiori informazioni riguardanti la raccolta ed il riciclaggio delle apparecchiature elettriche ed elettroniche residue (WEEE), siete invitati a visitare la nostra homepage www.aopen.com alla voce "Green Products".

Instruksjoner for Resirkulering og Oppsamling (Norwegian)

For å beskytte vår planet, kast ikke dette elektroniske utstyret sammen med vanlig avfall. For å beskytte vår natur og miljø, vennligst resirkuler dette produktet. For mer informasjon om oppsamling og resirkulering i henhold til Waste Electrical and Electronic Equipment (WEEE), se vår hjemmeside på www.aopen.com under "Green Products".

Programa de Tratamento de Resíduos de Equipamentos Eléctricos e Electrónicos (Portugese)

Para melhor protecção ambiental do nosso planeta terra, não coloque o dispositivo electrónico no receptáculo de lixo municipal. Para minimizar a poluição e garantir protecção máxima do ambiente global, recicle o produto. Para mais informações sobre acerca da recolha e reciclagem de Equipamento Eléctrico e Electrónico (WEEE), convidamos-lhe a visitar nossa página na Internet em www.aopen.com sobre "Green Products".

Instrucciones para depositar los productos electrónicos (Spanish)

Para proteger mejor el medio ambiente, por favor, no deposite los productos electrónicos en los contenedores de basura tradicionales. Para reducir la contaminación y proteger el medio ambiente se recomienda que los recicle. Para más información acerca de dónde depositar y cómo reciclar Equipos Electrónicos y Desperdicios Electrónicos (WEEE), por favor, visite la página web www.aopen.com y entre en la sección Productos Ecológicos ("Green Products").

Kassering (Swedish)

För att bättre värna om vår jord bör denna elektroniska utrustning ej kasseras tillsammans med vanligt avfall. För att minimera mängden föroreningar och så långt som möjligt skydda den globala miljön bör produkten återvinnas. För vidare information om insamling och återvinning av uttjänta elektriska och elektroniska produkter (Waste Electrical and Electronic Equipment, WEEE), besök avsnittet "Green Products" på vår hemsida, www.aopen.com.

Contents

Disposal Instructions	i
Welcome	1
Copyright © 2007 AOpen Inc. All Right Reserved	1
Notes and Warning labels used in the manual	2
Safety Information	2
Chapter 1 Introduction	3
1.1 Board and I/O Layout	3
1.2 Rear I/O Ports	4
1.3 System Block Diagram	6
Chapter 2 Hardware Installation	7
2.1 Installation Overview	7
2.2 Installing the CPU	8
2.3 Installing CPU Cooler	9
2.4 Installing CPU and System Fans	10
2.5 Installing System Memory Modules	11
2.6 Installing IDE Cable	12
2.7 Installing SATA Cable	13
2.8 Connecting Front Panel Cable	14
2.9 PCI x 1 Installation	15
2.10 Gigabit LAN	16
2.11 Connecting USB 2.0	17
2.12 Channel Audio	18
2.13 Connecting Front Audio	19
2.14 JP14 Clear CMOS Jumper	20
Chapter 3 Setting the BIOS	21
3.1 Introduction	21
3.2 How to use the Phoenix-Award BIOS Setup Program	21
3.3 How to Enter the BIOS Setup	22
3.4 Standard CMOS Features	23
3.5 Advanced BIOS Features	25
3.6 Advanced Chipset Features	27
3.7 Integrated Peripherals	28
3.8 Power Management Setup	30
3.9 PC health status	31
3.10 Load Optimized Defaults	32

3.11 Set Supervisor Password	33
3.12 Save & Exit Setup	34
3.13 Exit Without Saving	35
3.14 BIOS Upgrade under Windows Environment	36
Chapter 4 Special Features and Utilities	38
Driver Install Utility	38
Chapter 5 Installing Drivers	42
5.1 Driver Install Utility	42
5.2 Other useful Features	43
5.3 Useful Utilities	44
Chapter 6 Troubleshooting	45
Troubleshooting Steps	45
Chapter 7 Technical Support and Contact	46
AOpen Technical Support Team Global Locations	46
AOpen Technical Support	48

Welcome

First of all, we would like to express our gratitude for purchasing AOpen products. This motherboard is designed to meet all your personal needs with industry-leading features, the newest components and a strong focus on quality manufacturing and the testing and service that brings a positive computing experience that lasts for years.

This manual will introduce how this motherboard is installed. Please keep it well for your future reference. If you lose your printed manual, you may also go to our website at <http://www.aopen.com> to download an updated file in PDF format. Now, we would like to invite you to experience this user-friendly manual and all of the powerful functions this AOpen product offers.

Copyright © 2007 AOpen Inc. All Right Reserved

This document is based on the copyright laws in order to protect our company and reserve all rights. Under no circumstances are any types of duplicating and loading this brochure in any databases and media permitted without the express written permission of AOpen Inc.

Products and corporate names appearing in this manual may or may not be registered trademarks or copyrights of their respective companies, and are used only for identification or explanation and to the owners' benefit, without intent to infringe.

The logos of Adobe and Acrobat are the registered trademarks of Adobe Systems Incorporated.

The logos of AMD, Athlon, and Duron are the registered trademarks of Advanced Micro Devices, Inc.

The logos of Intel, Intel Celeron, Pentium II, III, Pentium 4, Pentium M and Core 2 Duo are the registered trademarks of Intel Corporation.

The logos of nVIDIA are the registered trademarks of nVIDIA Corporation.

The logos of Microsoft, Windows are the registered trademarks of Microsoft Corporation in America and other countries.

All the titles of the products and the trademarks mentioned in this manual are for the purpose of illustrative conveniences and are possessed by their respective firms.

We regret not informing about any changes in usage standards and other related information. AOpen reserves the right to alter or modify the content of this manual. In case of any mistakes or incorrect descriptions, which include those on the products, AOpen makes no guarantee or commitments.

Notes and Warning labels used in the manual

Please pay attention when you see the following symbols. They point out useful information for this motherboard and make users aware of certain conditions.

Warning: 	Please be careful when you see this mark. Can possibly injure yourself or the motherboard if you do not follow instructions.
--	--

Note: 	This contains knowledge you should know when assembling or using this AOpen product, or some helpful tip.
---	---

Tip: 	This Tip tells you some useful information that will make your installation go smoothly.
--	--

Caution: 	Highlights where mistakes often occur during assembly or use.
--	---

Safety Information

Warning: 	<ol style="list-style-type: none">1. Please wear a wrist strap and attach it to a metal part of the system unit before handling a component. You can also touch a metal object that has a ground connection or another metal surface.2. Always unplug the power before you make any jumper settings.3. Before you install or remove any components on the motherboard, please make sure to disconnect the power first to prevent damage to the motherboard or other components.
--	---

Chapter 1 Introduction

1.1 Board and I/O Layout

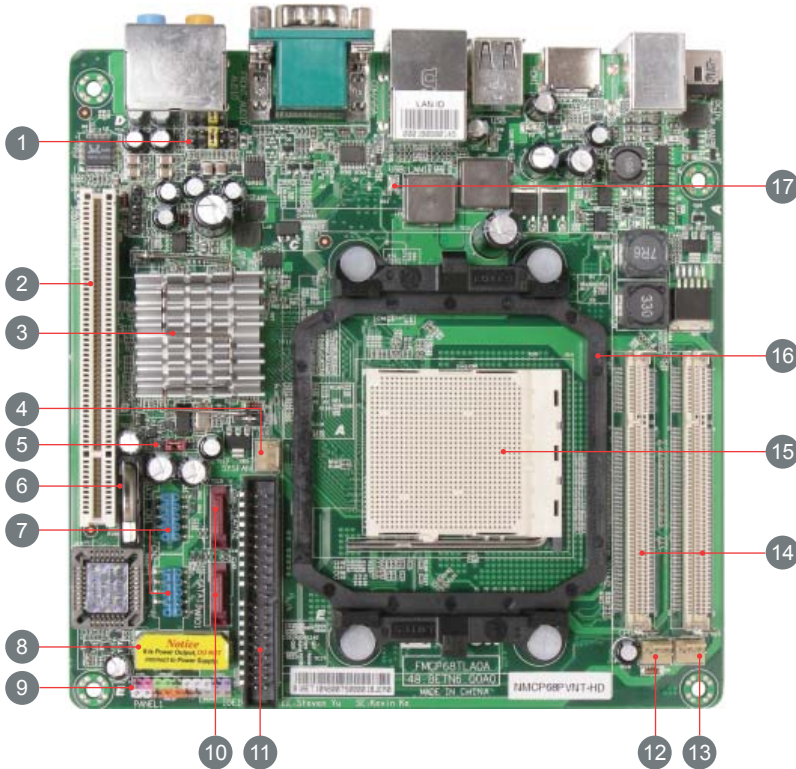

Table 1.1 Board Components

Item	Item
01. Front Audio Connector	10. SATA II Connector
02. PCI slot	11. IDE Connector
03. nVIDIA MCP68S	12. CPU Fan
04. System Fan	13. NB Fan
05. JP14 CMOS clear jumper	14. SO DIMM Slot x 2
06. Battery	15. LGA 775 CPU Socket P
07. USB 2.0 Connector x 2	16. Retention modules
08. 4-pin DC Power Output Connector	17. Standby LED
09. Front Panel Connector	

1.2 Rear I/O Ports

Figure 1.1 Board I/O Layout

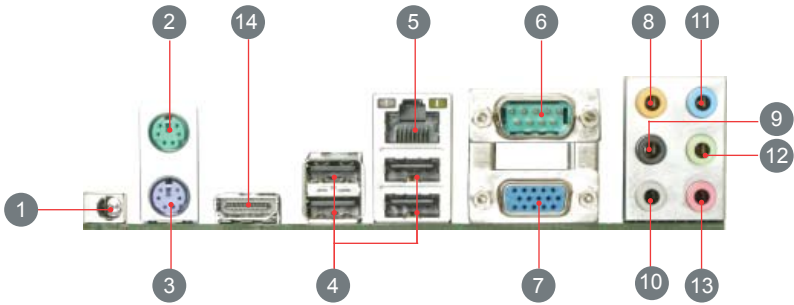

Table 1.2: Real I/O

Item	Item
01. 19V DC Adapter Conector	08. Rear Surround (S/PIDF Out)
02. PS/2 Mouse Connector	09. Center/Subwoofer
03. PS/2 Keyboard Connector	10. Side Surround
04. USB 2.0 Port x 4	11. Line-In (S/PIDF In)
05. RJ45 LAN Jack Port	12. Speaker Out
06. COM 1 Port	13. Mic-In
07. VGA Port	14. HDMI

Table 1.3: NMCP68ST / NMCP68PVNT Specifications Model

Model	NMCP68ST / NMCP68PVNT
CPU	AMD AM2 Athlon 64 x 2/64, Sempron under 65W
Chipset	nVIDIA® MCP68St / MCP68PVNT
Main Memory	DDRII 533/667 DDR DIMM x 2 DIMM Type : 256/512MB/1GB/2GB Max Memory : 4GB
Graphics	nVIDIA® Geforce 7 class
Storage	nVIDIA® MCP68St / MCP68PVNT
LAN (Giga)	Marvell 88E1116
Sound	Realtek® ALC888
USB	nVIDIA® MCP68St / MCP68PVNT
Slots	PCI Slot x 1 IDE x 1
Back Panel I/O	PS/2 Keyboard x 1, PS/2 Mouse x 1 VGA Port x 1, COM Port x 1, USB Port x 4, LAN Port x 1, Speaker Out x 1, Line-In x 1, Mic-In x 1 Side Surround x 1, Rear Surround x 1, Center/Subwoofer x 1 HDMI x 1 (MCP68PVNT only)
On-Board Connector	4-pin DC Power Output Connector Serial ATA II Channel x 2 Front Panel x 1 Front Audio x 1 CPU FAN x 1, System FAN x 1, NB FAN x 1 USB 2.0 pin header 10 pins x 2
BIOS	Award PnP 16Mb Flash ROM BIOS
Board Size	170 mm x 170 mm

* Specifications are subject to change without notice.

1.3 System Block Diagram

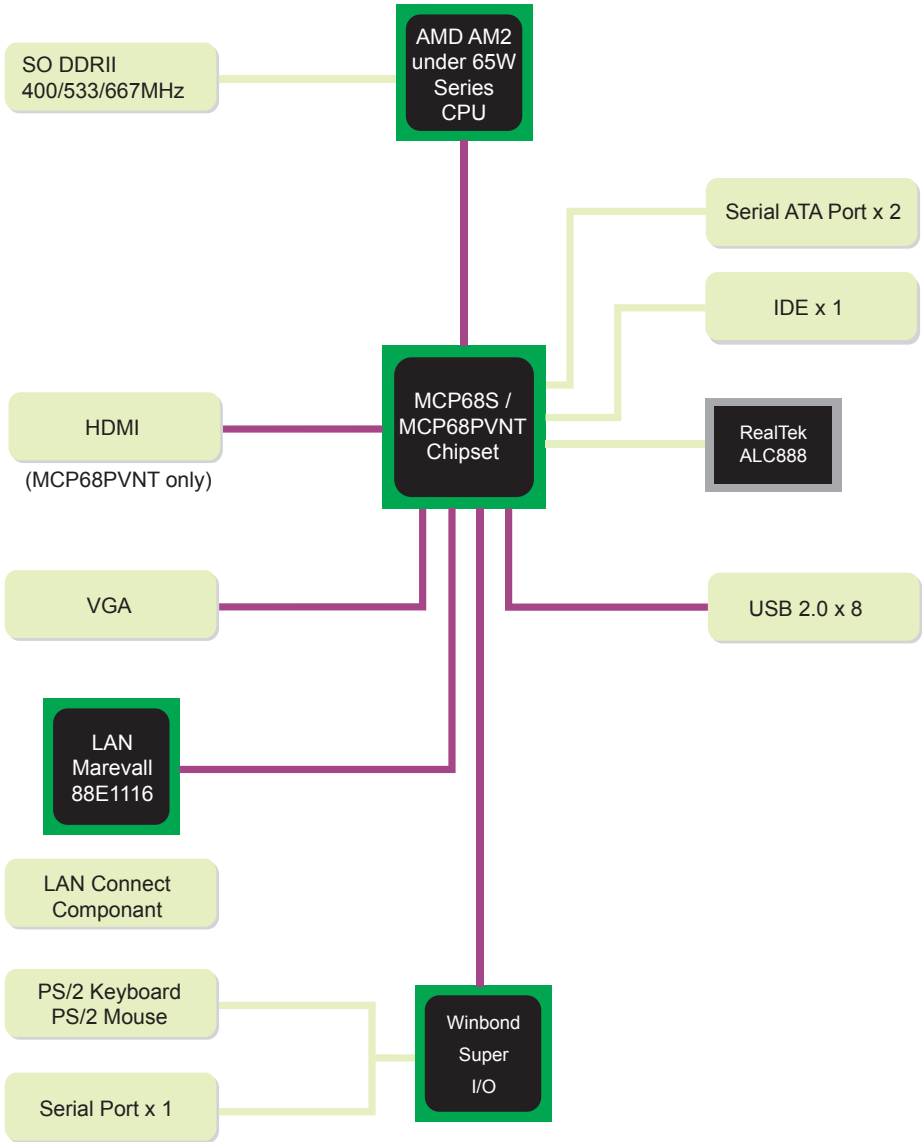

Chapter 2 Hardware Installation

2.1 Installation Overview

Generally, when installing a new motherboard and peripherals into a chassis, people typically follow a certain order of steps for the installation. The list below are the general steps:

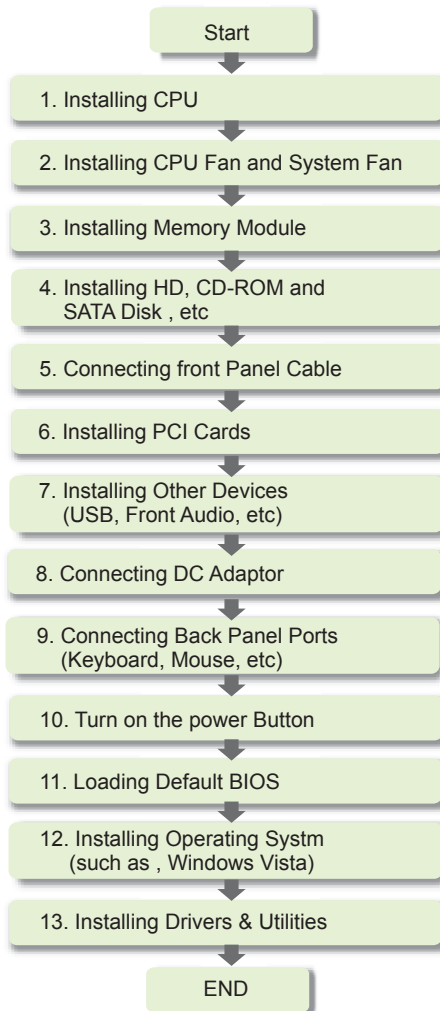

2.2 Installing the CPU

1. Erect CPU socket lever up.
2. Locate Pin 1 in the socket and look for a golden arrow on the CPU upper interface. Match Pin 1 and golden arrow. then gently put CPU onto socket.
3. Press lever back to CPU socket, and then it's done.

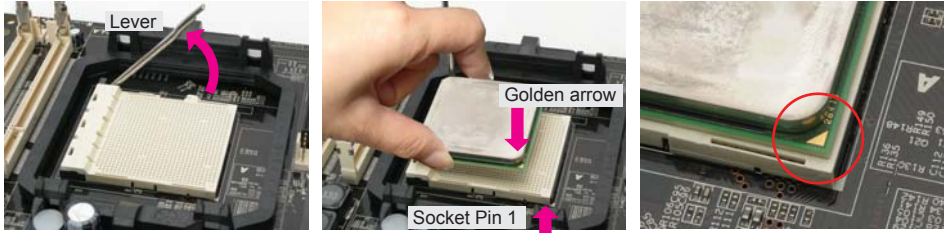

Warning:



Note:

1. If you do not match the CPU socket Pin 1 and CPU golden arrow well, you may damage the CPU.
2. AMD CPU power consumption can not over 65W !

CPU Frequency Table

Spec.	Model	ID / L2 / FSB / Ratio / Freq.	Vender
(DO)45W	Athlon 64 X2 BE-2400	FB2 / 2*512M / 1000MHz / 11.5 / 2.30GHz	AMD
(DO)45W	Athlon 64 X2 BE-2350	FB2 / 2*512M / 1000MHz / 10.5 / 2.10GHz	AMD
(DO)45W	Athlon 64 X2 BE-2300	FB2 / 2*512M / 1000MHz / 9.5 / 1.90GHz	AMD
(DE)45w	Sempron LE-1200	FF1 / 512M / 800Hz / 10.5 / 2.10GHz	AMD
(DD)65w	Athlon 64 X2 4800+	FB1 / 512K*2 / 1000MHz / 12.5 / 2.50GHz	AMD
(DD)65w	Athlon 64 X2 4400+	FB1 / 512K*2 / 1000MHz / 11.5 / 2.30GHz	AMD
(DD)65w	Athlon 64 X2 4000+	FB1 / 512K*2 / 1000MHz / 10.5 / 2.10GHz	AMD
(DD)65w	Athlon 64 X2 3600+	FB1 / 512K*2 / 1000MHz / 9.5 / 1.90GHz	AMD
(DE)45w	Athlon 64 3200+	FF1 / 512K / 1000MHz / 10 / 2.00GHz	AMD
(CZ)65w	Athlon 64 X2 5200+	F33 / 1M*2 / 1000MHz 13.0 / 2.60GHz	AMD
(CZ)65w	Athlon 64 X2 4600+	F33 / 512K*2 / 1000MHz / 12 / 2.40GHz	AMD
(CS)65w	Athlon 64 X2 4600+	F32 / 512K*2 / 1000MHz / 12 / 2.40GHz	AMD
(CZ)65w	Athlon 64 X2 3800+	F33 / 512K*2 / 1000MHz / 10 / 2.00GHz	AMD

Above table is AMD® AM2 Athlon 64 x 2 / 64, Sempron CPU numbers and simple specification for your reference only.

2.3 Installing CPU Cooler

Gently put down the CPU fan on CPU socket with four studs aimed directly over the four mounting holes.



Warning:



Always use the correct amount of thermal grease when mounting the CPU cooler. Follow the instructions closely.

Note:



This cooler and picture shown might be different from your purchased product.

2.4 Installing CPU and System Fans

Plug the CPU fan cable to the 3-pin CPU FAN connector.
If you have a chassis fan, you can also plug it into the SYSFAN connector.

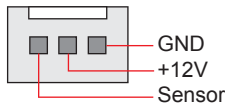
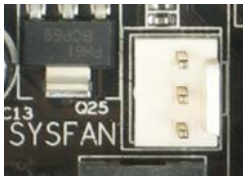
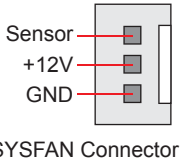
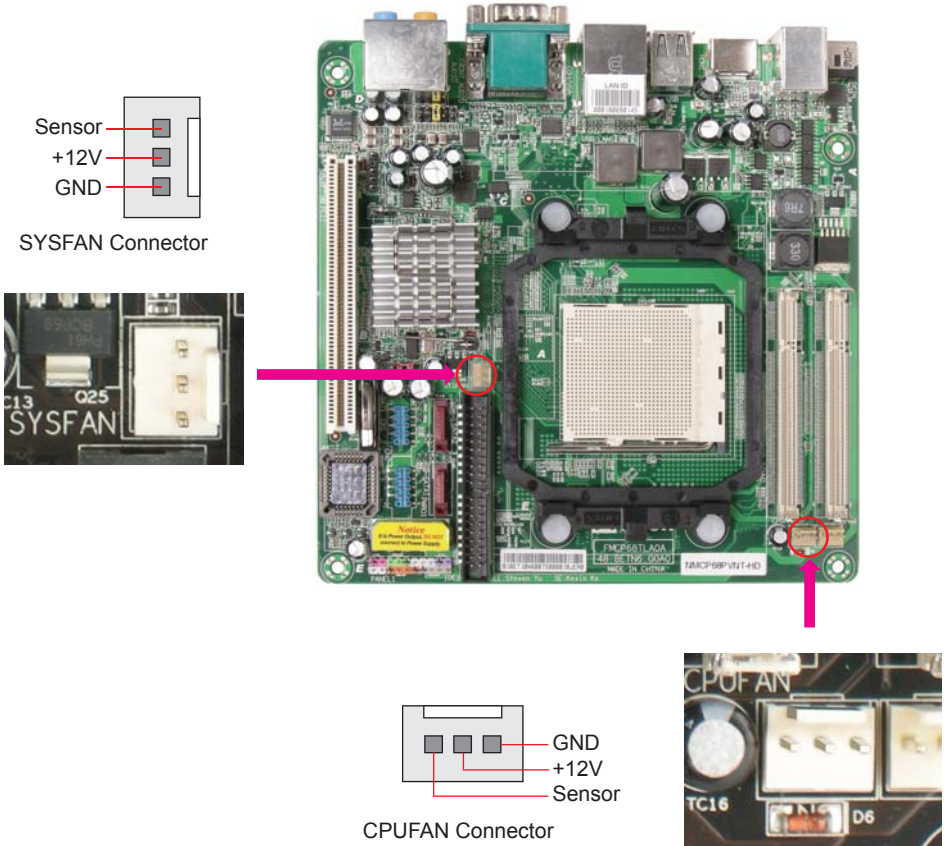

CPUFAN Connector



Note:



Some fans do not have a sensor pin, so fan monitoring is not supported.

2.5 Installing Memory Module

The motherboard provide SODIMM type memory support. There're two SODIMM memory slots which motherboard provided. The installation of memory module as below.

1. Put the memory module with correct direction. Notice there's one stick to make sure direction is correct.
2. Plug in memory module into SODIMM slot with angle 20~30°. Make sure memory module plug into slot completely.
3. There're tabs which located in the side of SODIMM holder. Use finger to push memory module vertically until the tabs lock memory module tightly.
4. Now, the memory modules have been plugged properly with horizontal flat.

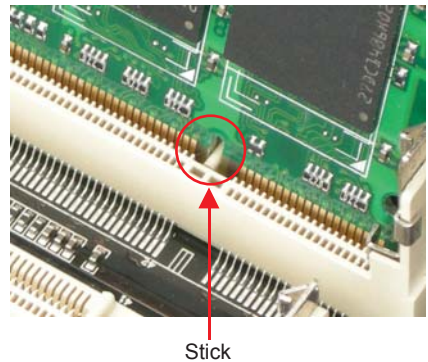
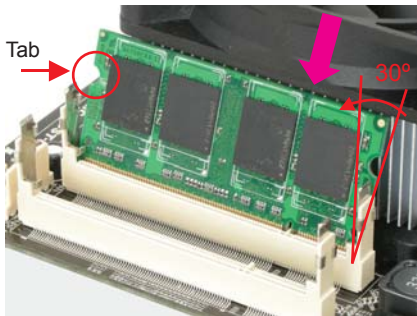

Note:



Pay careful attention to align the slot in the middle of the memory module. The tabs of the DIMM slot will clip to hold the DIMM in place when the DIMM touches the slot's bottom. You can hear it click into place.

2.6 Installing IDE Cable

The motherboard provides one IDE connector which allow you to connect two ATA 33/66/100 IDE devices like HDD.

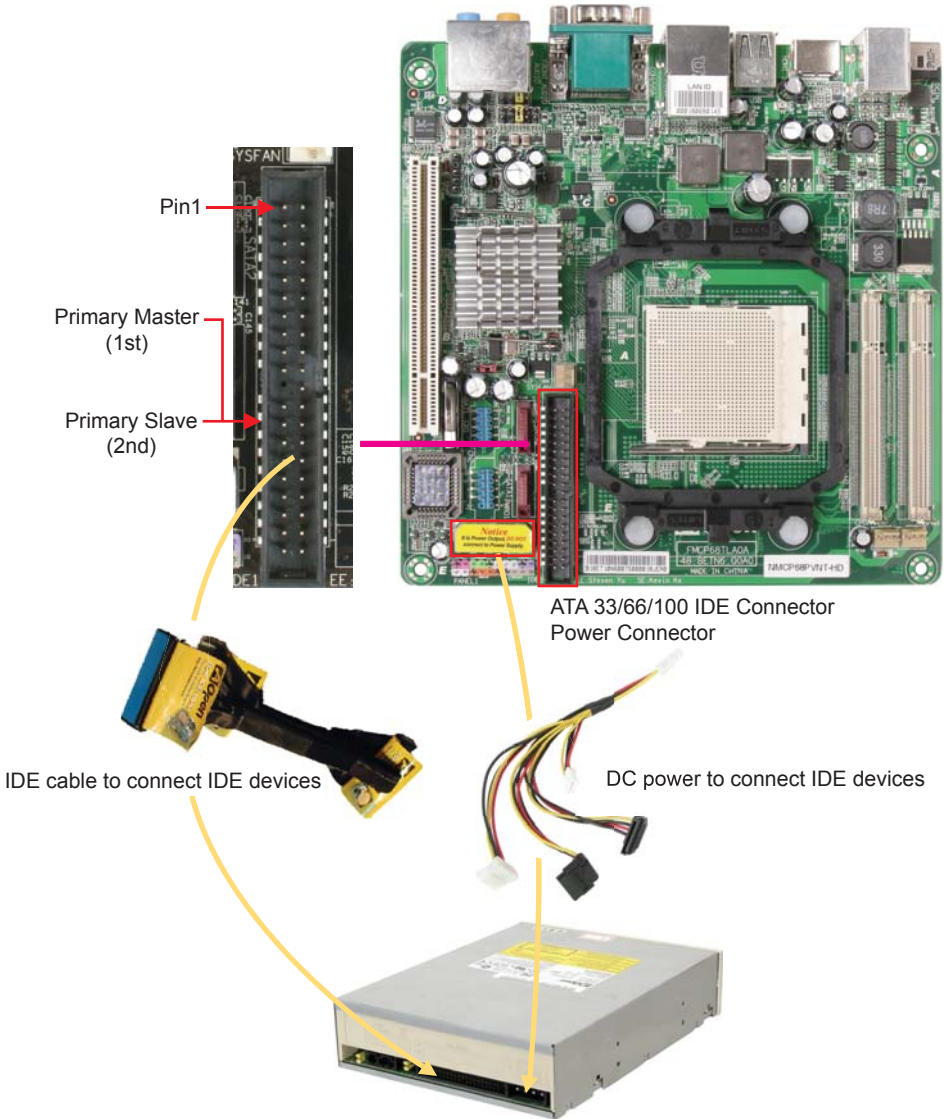

2.7 Installing SATA Cable

The mother board provides two SATA connectors.

And the nvidia MCP68PVNT supports RAID0 & RAID1 , refer to Chapter “Configuring SATA Hard device(s) for instructions on configuring a RAID Array. RAID0 or RAID1 configuration requires at least two hard drives.

Connect SATA cable to the on board SATA connector.

You can find SATA cable in our package. (this is SATA signal cable)

And please also connect 5V power connector with SATA power cable.

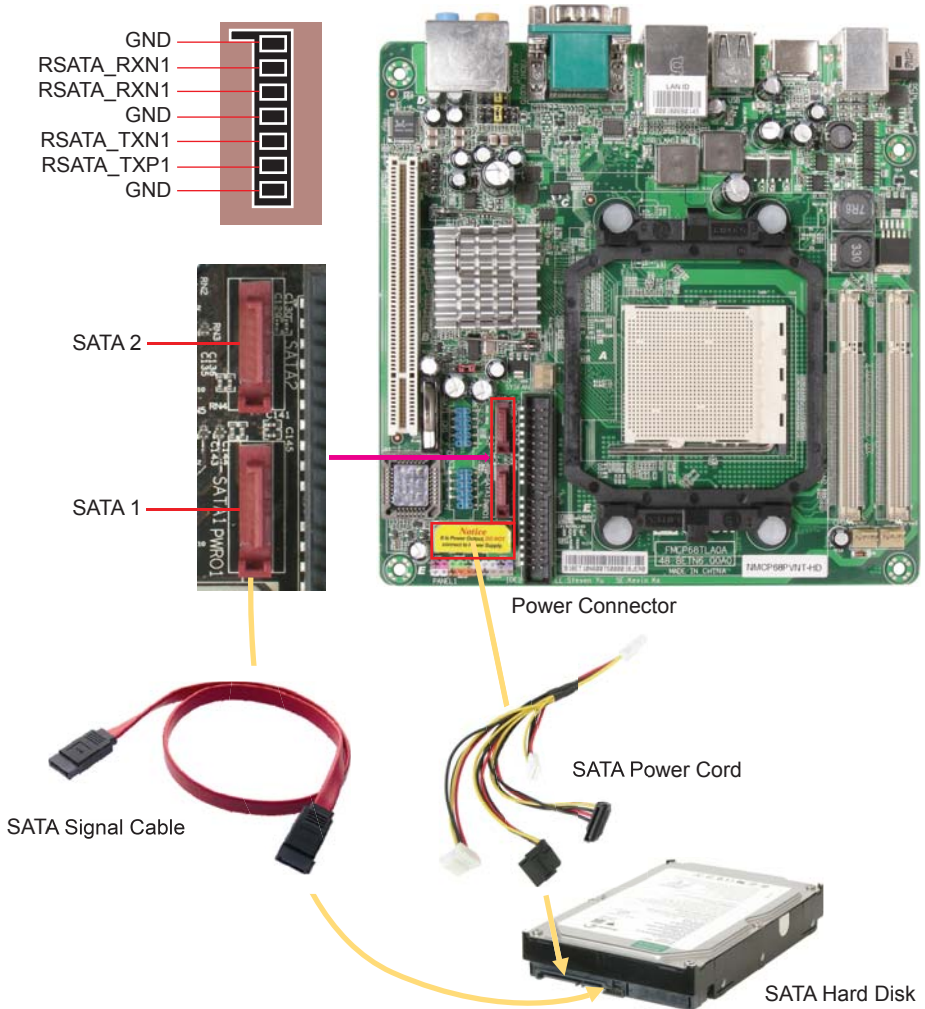

2.8 Connecting Front Panel Cable

Attach the power LED, speaker and reset switch connectors to the corresponding pins. If you enable “Suspend Mode” item in BIOS Setup, the ACPI & Power LED will keep flashing while the system is in suspend mode.

Locate the power switch cable from your housing, which is a 2-pin female connector from the housing front panel. Plug this connector to the soft-power switch connector marked SPWR.

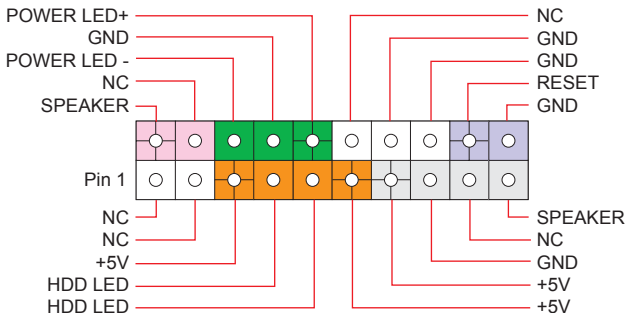

Front Panel Connector

2.9 PCI x 1 Installation

The 1x PCI cards have SATA II and Firewire and USB cards ... etc.

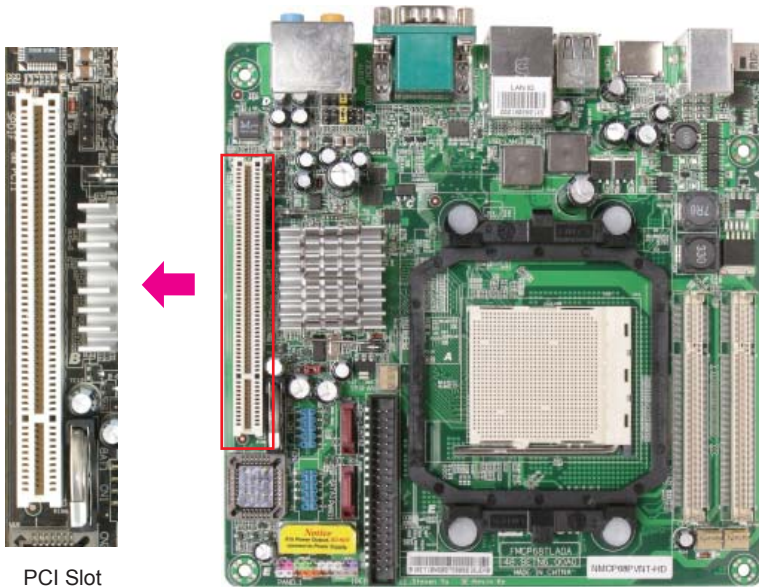

2.10 Gigabit LAN

One of the strengths is the Gigabit LAN controller on board, this mother board provides 10/100/1000Mbps Ethernet for office and home use. The Ethernet RJ45 connector is located above the USB connectors. The right hand side LED indicates link mode; it lights in yellow when linking to a network. The left hand side LED indicates the transfer mode and will light in green when data is transferring at 100Mbps (never lights while at 10Mbps), and will light in orange when transferring in Gigabit mode. To enable or disable this function, you simply adjust it through the BIOS. To enable the LAN wakeup function, you have to set the “Wake on PCI Card” to enable in the BIOS “Power Management Setup” section.

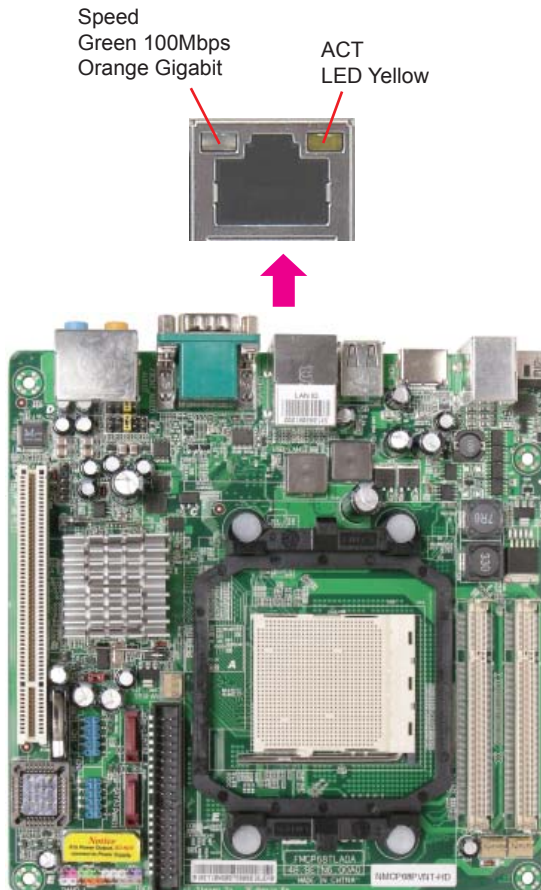

2.11 Connecting USB 2.0

This motherboard provides eight USB 2.0 ports to connect USB devices such as mouse, keyboard, modem, printer, etc. There are four ports on the back panel. You can use proper cables to connect Front USB connector to USB modules or chassis front panel.

	1		
+ 5V			+5V
SBD6 -			SBD7 -
SBD6+			SBD7+
GND			GND
KEY			NC

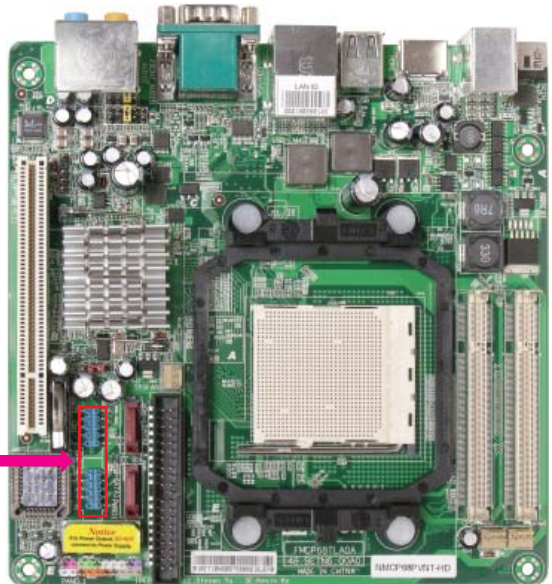
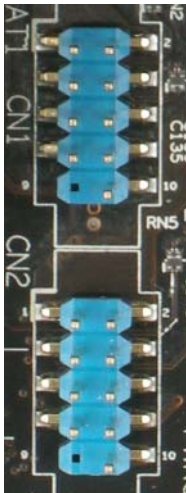

USB 2.0 Connector

2.12 Channel Audio

This motherboard comes with an Azalia (Realtek ALC888) codec, which supports the latest 7.1 Channel sound with high quality audio effects, bringing you an excellent audio experience. This motherboard provides 7.1 Channel ports as shown below. The diagram represents the standard location of all speakers for 7.1 Channel sound use. Please connect the plug of your front speakers to the green “Speaker out” port, rear surround speakers to orange port, side surround speakers to gray port and both of the center and subwoofer speakers to the black port on the back panel.

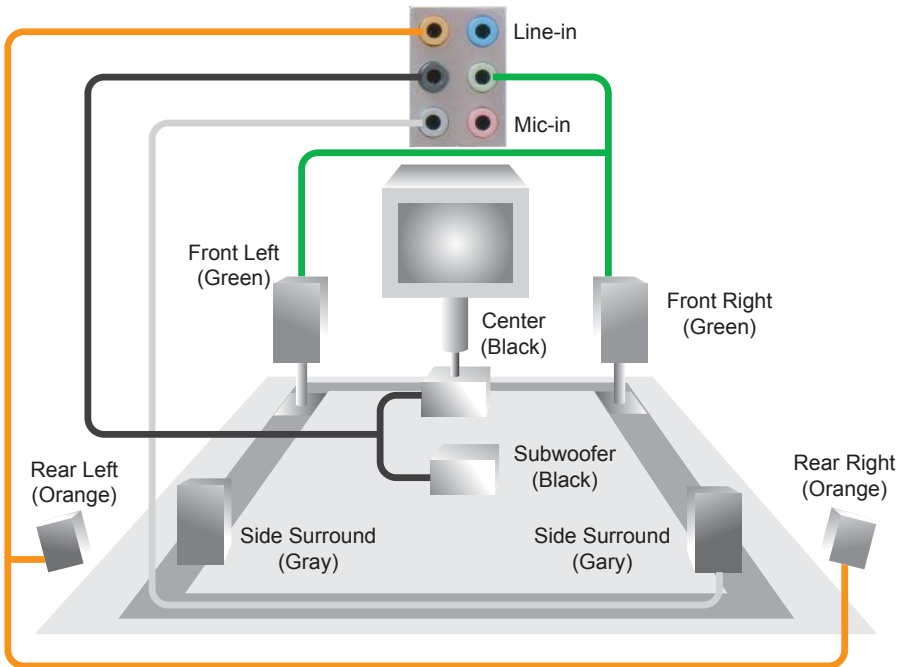

2.13 Connecting Front Audio

If the chassis is designed with an audio port on the front panel, you'll be able to connect onboard audio to the front panel through this connector. Please remove the jumper cap from the Front Audio Connector before you connect the cable. Do not remove this yellow jumper cap if your housing doesn't have an audio port on the front panel.

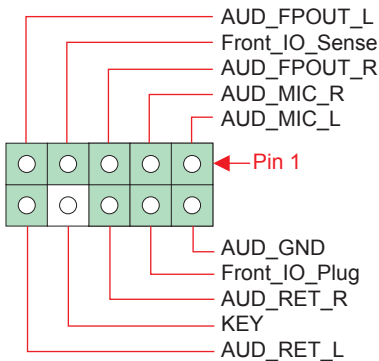
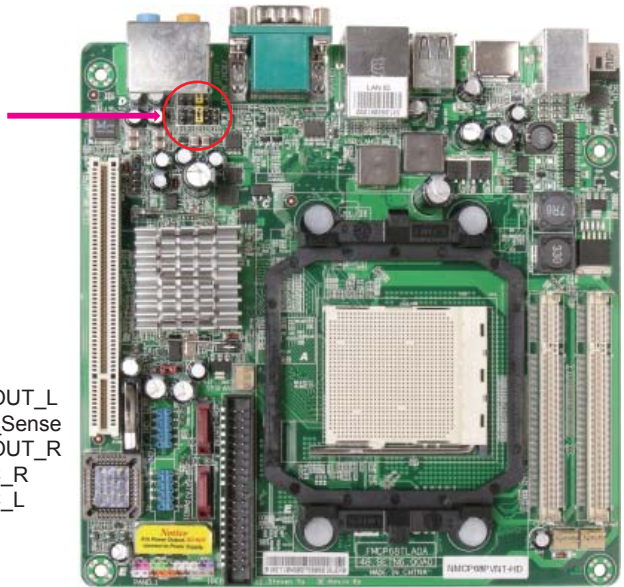
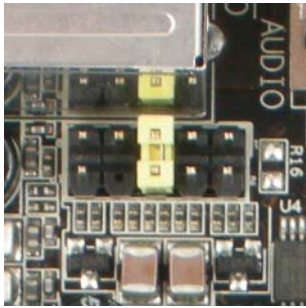

Front Audio Connector

2.14 JP14 Clear CMOS Jumper

You can clear CMOS to restore system default settings. To clear the CMOS, follow the procedure below.

1. Turn off the system and unplug the AC power.
2. Locate JP14 and short pins 2-3 for a few seconds.
3. Return JP14 to its normal setting by connecting it to Pin 1-2 again.
4. Connect ATX power cable back to connector PWR3.

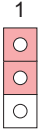

Normal (Default)

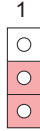

Clear CMOS

JP14 Clear CMOS Jumper

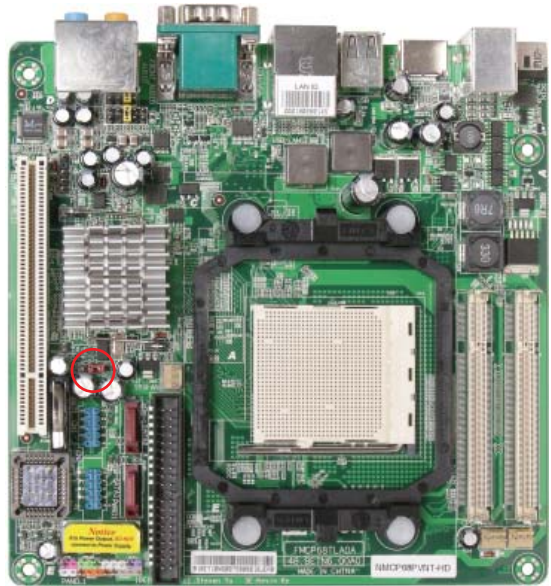
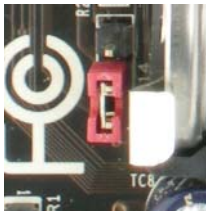

Chapter 3 Setting the BIOS

3.1 Introduction

System parameters can be modified by going into BIOS Setup menu; this menu allows you to configure the system parameters and save the configuration into the 128 byte CMOS area (normally in the RTC chip or in the main chipset).

The Phoenix-Award BIOS™ that is installed in the Flash ROM of the motherboard is a custom version of an industry standard BIOS. The BIOS provides critical low-level support for standard devices such as hard disk drives, serial and parallel ports.

AOpen's R&D engineering team has optimized most BIOS settings of this motherboard. However, some default settings of the BIOS cannot fine-tune items that are controlled by chipset. Therefore, this chapter is intended to guide you and help you to configure some other settings. To enter the BIOS setup menu, press when POST (Power-On Self Test) screen is shown on your monitor.

Note:



Because BIOS code is the most often changed part on motherboard, the BIOS information contained in this manual may be different from the BIOS version that comes with your motherboard.

3.2 How to use the Phoenix-Award BIOS Setup Program

Generally, you can use arrow keys to highlight items that you want to choose, press <Enter> key to select, and use <Page Up> and <Page Down> keys to change setting values. You can press <Esc> key to quit Phoenix-Award™ BIOS setup program. The following table provides details about how to use the keyboard in the Phoenix-Award™ BIOS setup program.

Key	Description
Page Up or +	Change setting to next value or increase the value.
Page Down or -	Change setting to previous value or decrease value.
Enter	Select the item.
Esc In main menu	Quit without saving any changes.
In sub menu	Exit current menu to main menu.
Up Arrow	Highlight previous item.
Down Arrow	Highlight next item.
Left Arrow	Move the light bar to left side of menu.
Right Arrow	Move the light bar to right side of menu.
F6	Load Setup Default setting value from CMOS.
F7	Load turbo setting value from CMOS.
F10	Save changed settings and exit setup program.

3.3 How to Enter the BIOS Setup

After finishing the jumper settings and connecting cables, you can power on and enter the BIOS Setup. Press during POST (Power-On Self Test) and choose “Load Fail-Safe Defaults” for recommended optimal performance.

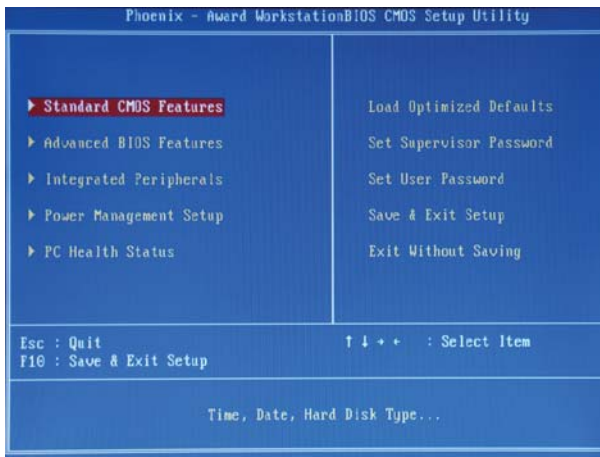

Caution:		Please avoid of using “Load Optimized Defaults”, unless you are certain your system components (CPU, SDRAM, HDD, etc.) have been proven acceptable for use.
-----------------	--	---

3.4 Standard CMOS Features

The “Standard CMOS Setup” sets the basic system parameters such as the date, time, and the hard disk type. Use the arrow keys to highlight an item and <PgUp> or <PgDn> to select the value for each item.



Standard CMOS Features > Date

To set the date, highlight the Date parameter. Press <PgUp> or <PgDn> to set the current date. The date format is month, date, and year.

Standard CMOS Features > Time

To set the time, highlight the Time parameter. Press <PgUp> or <PgDn> to set the current time in hour, minute, and second format. The time is based on the 24 hour military clock.

Standard CMOS features > IDE Channel 0 Master

Standard CMOS features > IDE Channel 0 Slave

Standard CMOS features > IDE Channel 1 Master

Standard CMOS features > IDE Channel 1 Slave

Standard CMOS features > IDE Channel 2 Master

Standard CMOS features > IDE Channel 2 Slave

Standard CMOS features > IDE Channel 3 Master

This item lets you select the IDE hard disk parameters that your system supports. These parameters are Size, Number of Cylinder, Number of Head, Start Cylinder for Pre-compensation, Cylinder number of Head Landing Zone and Number of Sector per Track. The default setting is Auto, which enables BIOS to automatically detect the parameters of installed HDD (Hard Disk Drive) at POST (Power-On Self Test). If you prefer to enter HDD parameters manually, select Manual.

Standard CMOS Features > IDE Channel 0 Master > IDE HDD Auto-Detection

Press “Enter” to auto-detect parameters of HDD.

Standard CMOS Features > IDE Channel 0 Master > IDE Channel 0 Master

Define the parameters of IDE devices in Channel 0 (Master or Slave).

Available options:

None: If there is no device, please select “None” for speeding boot up.

Auto: This will enable BIOS to auto-detect parameters of IDE device. (Default)

Manual: Allow users to define parameter of IDE device.

Standard CMOS Features > IDE Channel 0 Master > Access Mode

Set the using mode of HDD. Available options: CHS / LBA / Large / Auto (default). User can select the mode according to the label on HDD.

Cylinder: Enter cylinder number

Head: Enter head number

Precomp: Write precompensation

Landing Zone: Location of head

Sector: Sector number

Standard CMOS Features > HaltOn

This parameter enables you to stop the system in case of Power-On Self Test (POST) error. Available items: All errors / No errors / All, But Keyboard

3.5 Advanced BIOS Features

This screen appears when you select the option “Advanced BIOS Features” from the main menu.



Advanced BIOS Features > Removable Device Priority

Advanced BIOS Features > Hard Disk Boot Priority

Advanced BIOS Features > CD-ROM Boot Priority

This parameter allows you to specify the system boot up search sequence.

Advanced BIOS Features > Hyper-Threading Technology

Provides thread-level parallelism on each processor, resulting in more efficient use of processor resources, higher processing throughput, and improved performance for multithreaded software.

Available options: Disabled, Enabled

Advanced BIOS Features > First Boot Device

Advanced BIOS Features > Second Boot Device

Advanced BIOS Features > Third Boot Device

Advanced BIOS Features > Boot Other Device

Allows you to specify the system boot sequence.

Available options:

Removable: Floppy, USB, ZIP...etc

Hard Disk: Hard Disk Drives

CD-ROM: CD-ROM, DVD-ROM...etc

LAN: LAN Card with boot ROM

Advanced BIOS Features > Security Option

The “System” option limits access to both the System boot and BIOS setup. A prompt asking you to enter your password appears on the screen every time you boot the system. The “Setup” option limits access only to BIOS setup. To disable the security option, select Password Setting from the main menu, don’t type anything and just press <Enter>.

Advanced BIOS Feature > Frame Buffer Size

Advanced BIOS Features > Full Screen Logo Show

This item allows user to select to show or hide “Full Screen logos” or “Vivid BIOS logos”. Available options: Disabled, Enabled

3.6 Integrated Peripherals

This submenu appears if you select the option “Integrated Peripherals” from the main menu. This option allows you to configure the I/O features.

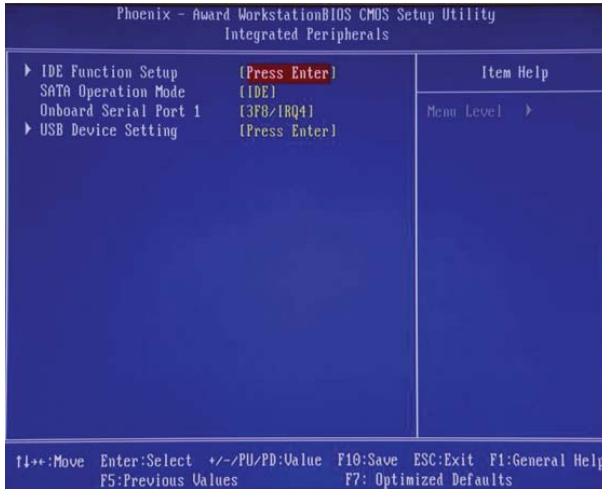

Integrated Peripherals > IDE Function Setup

SATA Operation Mode > This item is used to select IDE/RAID mode

IDE : Configures the SATA controller to PATA mode(Default)

RAID : Enables RAID for SATA controller

Integrated Peripherals> Onboard Serial Port 1 >Disable 3F8/IRQ4 3E8/IRQ4 2E8/IRQ3 Auto

Integrated Peripherals> USB Device Setting >USB1.0 Controller

This item lets you enable or disable the USB 1.0 controller

Integrated Peripherals> USB Device Setting >USB2.0 Controller

This item lets you enable or disable the USB 2.0 controller

Integrated Peripherals> USB Device Setting >USB Keyboard Function

This item lets you enable or disable the USB Keyboard Function

Integrated Peripherals> USB Device Setting >USB Keyboard Function

This item lets you enable or disable the USB Mouse

3.7 Power Management Setup

The Power Management Setup screen enables you to control the motherboard green features.



Power Management > ACPI Suspend Type

The function allows you to select suspend types. S1 is power On Suspend and S3 is Suspend to RAM, Available Options : S1, S3 & S1 & S3

Power Management > Soft-Off by PBTN

This is a specification of ACPI and supported by hardware. When Delay 4 sec. is selected, the soft power switch on the front panel can be used to control power On, Suspend and Off. If the switch is pressed for less than 4 seconds during power On, the system will go into Suspend mode. If the switch is pressed for longer than 4 seconds, the system will be turned Off. The default setting is Instant-Off. If Instant-Off is selected the soft power switch is only used to control On and Off, so there is no need to press it for 4 seconds, and there is no Suspend.

Available Options: Delay 4 sec., Instant-Off

Power Management > WOL(PME#) From Soft-Off>

This is a function of PCI specification 2.2. PCI bus supports standby current to PCI card and PCI card can wakeup system if it detects certain activity.

Available options: Disabled, Enabled

Power Management > WOR(RI#) From Soft-Off>

This option lets you specify enable or disable Wake On Modem Ring function.
Available options: Disabled, Enabled

Power Management > Power-On by Alarm>

This function can provide alarm to resume system immediately.
Available options: Disabled, Enabled

Power Management > Power-On by Alarm> Date (of Month) Alarm>

This item is displayed when you enable the Wake On RTC Timer option. Here you can specify what date you want to wake up the system. For Example, setting to 15 will wake up the system on the 15th day of every month.

Power Management > Power-On by Alarm> Time (hh:mm:ss) Alarm>

This item is displayed when you enable the Wake On RTC Timer option. Here you can specify what time you want to wake up the system.

Power Management > HPET Support>

High Precision Event Timer is a hardware timer , The HPET can produce periodic interrupts at a much higher resolution than the RTC and is often used to synchronize multimedia streams, providing smooth playback and reducing the need to use other timestamp calculations

Power Management > Power On Fuction>

This item is used to select Wake on Keyboard/Mouse mode.

Power Management > Power On Fuction> Password:

Disable the function of power button and let the system can only be powered on through the preset keys(like a password).

KB Power ON Password: You can specify 1-5 keys as a password.

Power Management > Power On Fuction> Hot Key:

If selecting this option, you also need to specify the hot key from “Hot Key Power On” item.

Hot Key Power On:

If you select “Hot Key” option in “Power On Function” Item, you need to specify a hot key here.

Power Management > Power On Fuction> Any Key:

This function allows you wake up the system by clicking any key.

Power Management > Power On Fuction> Button Only:

Disable Wake on KB/MS function. You can boot up your system by power button only.

Power Management > AC PWR Auto Recovery>

A traditional ATX system should remain at power off stage when AC power resumes from power failure. This design is inconvenient for a network server or workstation, without an UPS, that needs to keep power-on. This item is used to solve this problem. Selecting On enabling system to automatically power-on after AC power resumes; in the other hand, the system will remain power-off if you select Off.

If Former-Sts (former status) option is selected, the system will power-on or power-off based on the original state. Available options: Former-Sts, On, Off

3.8 PC health status

The Power Management Setup screen enables you to control the motherboard green features.

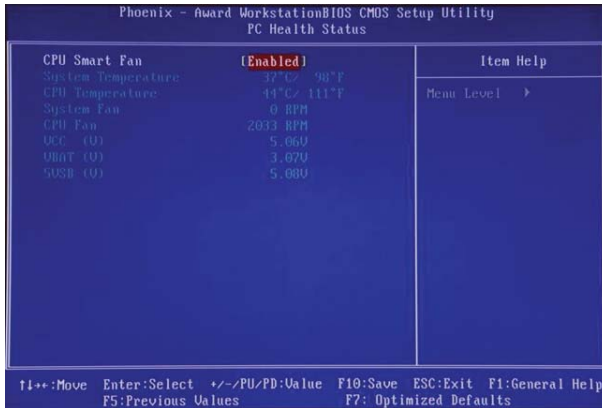

PC Health Status

The PC Health Status can bring PC important safety parameters for detect Health of your system.

PC Health Status > CPU Smart Fan

The CPU smart fan can detect CPU temperature and adjust fan speed automatically. That can ensure you to have silent & best working environment for system. Suggestion: Enabled it.

Available options: **Disabled, Enabled**

PC Health Status > System Temperature

PC Health Status > CPU Temperature

PC Health Status > System Fan

PC Health Status > CPU Fan

PC Health Status > VCC (V)

PC Health Status > VBAT (V)

PC Health Status > SVSB (V)

PC health status bring you on the system temperature, CPU temperature, CP Fan speed, Vcore, VCC, VBAT, SVSB – these important system parameters for you to check the health status of your system.

3.9 Load Optimized Defaults

The “Load Optimized Defaults” is used to load the factory defaults for BIOS and Chipset features that are detected by the system.

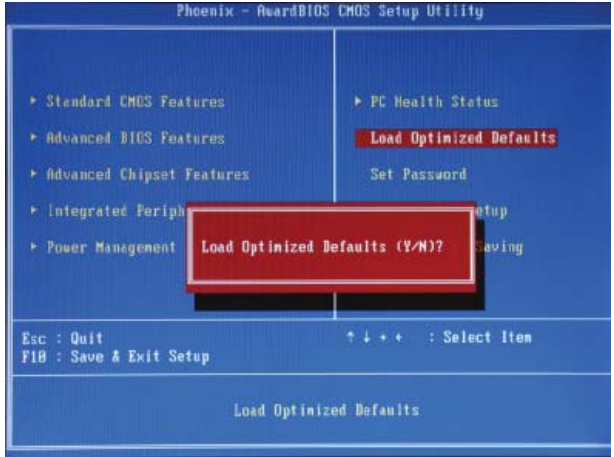

3.10 Set Password

A Password prevents unauthorized use of your computer. If you set a password, the system prompts for the correct password before boot or access to Setup.



To set a password:

1. At the prompt, type your password. Your password can be up to 8 alphanumeric characters. When you type the characters, they appear as asterisks on the password screen box.
2. After typing the password, press the “Enter” key.
3. At the next prompt, re-type your password and press the “Enter” key again to confirm the new password. After the password was typed-in, the screen automatically reverts to the main screen. To disable the password, press “Enter” when being prompted to input the password.

3.11 Save & Exit Setup

A Password prevents unauthorized use of your computer. If you set a password, the system prompts for the correct password before boot or access to Setup.

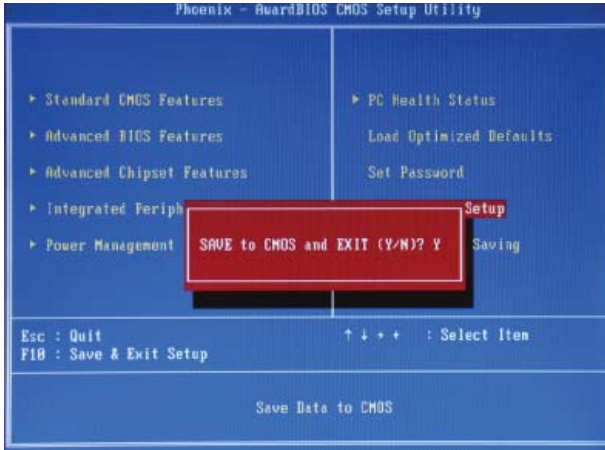

3.12 Exit Without Saving



3.13 BIOS Upgrade under Windows Environment



With outstanding R&D ability of AOpen, we now bring you the EzWinFlash BIOS wizard. With an eye on convenience for users, EzWinFlash combines the BIOS binary code and flash module together, so the only thing you have to do is just click on the utility and downloaded from web and let it help you complete the flash process automatically. EzWinFlash detects your motherboard and checks the BIOS version to prevent your system from any possible failure. Moreover, EzWinFlash takes into consideration any Windows platform you might be using, no matter if you're using Windows 95/98, 98SE/ME, NT4.0/2000, or Windows XP.

In order to provide a much more user-friendly operating environment, AOpen EzWinFlash is natively designed to have multi-language function to make it easier way for users to change the BIOS setting.

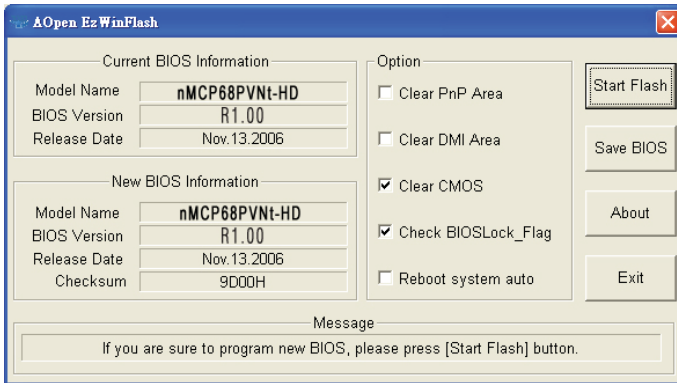

Caution:



You are taking a risk of BIOS flash failure when you update your system. If your motherboard is working stable, and there are no major bugs to be fixed by a latter BIOS revision, we recommend that you DO NOT upgrade your BIOS. If you intent on upgrade PLEASE MAKE SURE you get the right BIOS revision for your motherboard model so as to avoid any possible failure.

Note:



The model name on this BIOS picture is for reference only. It may not be the same model with your motherboard.

You may accomplish BIOS upgrade procedure with EzWinFlash according to following steps, and it's **STRONGLY RECOMMENDED** to close all applications before you start the upgrades.

Download the latest version of BIOS package zip file from AOpen official web site. (Ex: <http://english.aopen.com.tw/>)

Unzip the downloaded BIOS package (ex: WSGMAXII102.ZIP) with WinZip (<http://www.winzip.com>) in Windows environment.

Save the unzipped files into a folder, for example, WSGMAXII102.EXE & WSGMAXII102.BIN.

Double click WSGMAXII102.EXE; EzWinFlash will detect the model name and BIOS version of your motherboard. If you got the wrong BIOS, you will not be allowed to proceed with the flash steps.

You may select a preferred language in main menu, then click [Start Flash] to begin the BIOS upgrade procedure.

EzWinFlash will complete all the process automatically, and a dialogue box will pop up to ask you to restart Windows. Click [YES] to reboot Windows.

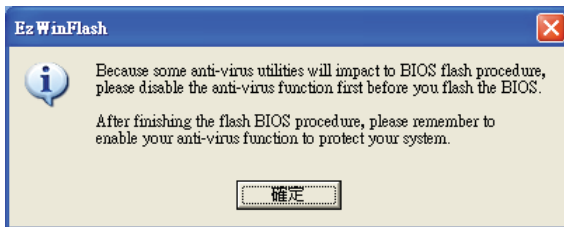

Press at POST to enter BIOS setup screen; choose “ Load Setup Defaults ”, then “ Save & Exit Setup ”. Done!

It is strongly recommended **NOT** to turn off the power or run any applications during FLASH PROCESS.

Warning: 	The new BIOS upgrade will permanently replace your original BIOS setting when flashing. You may need to reconfigure the BIOS setting before your system works normally again.
---	---

Chapter 4 Special Features and Utilities

4.1 Driver Install Utility

RAID (Redundant Array of Independent Disks)

With nVIDIA MCP68PVNT implemented, nMCP68PVnt-HD provides RAID 0 and RAID 1 function for the Serial ATA hard disks.

Installation Raid driver under window installation

In order to make sure your system can recognize and operate Serial ATA RAID device smoothly, one have to install Raid Driver under window installation
When start installing windows, then press "F6" when prompted at the beginning of window setup



Press the “S” key to select “Specify Additional Device

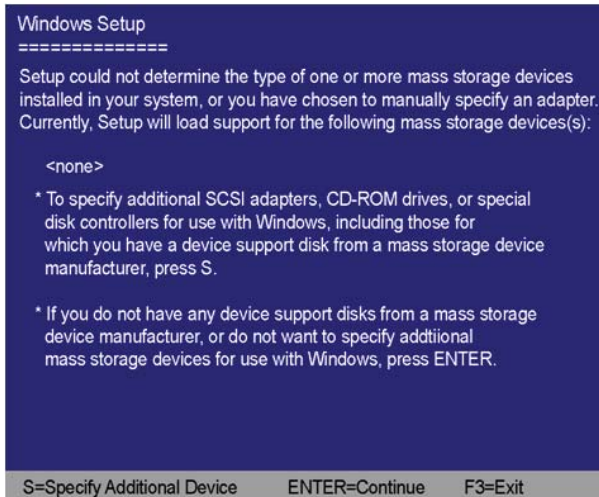

Please insert Raid Driver floppy Disk into Drive A:
After Raid driver floppy disk insert properly in drive A, please “ENTER” to continue.

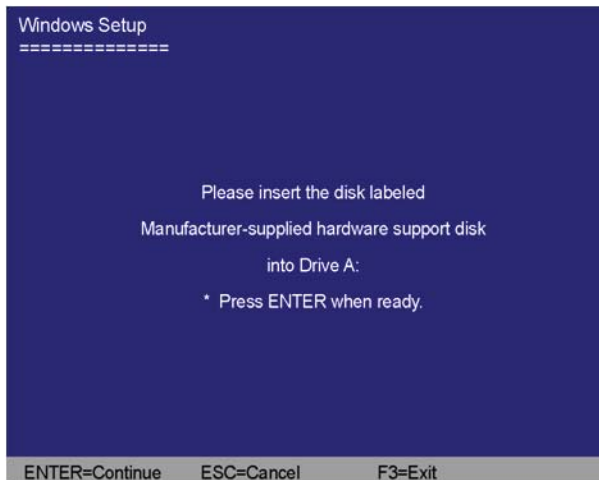



Please select “nVIDIA nForce Storage Controller (required)”
Press “enter” after selection.

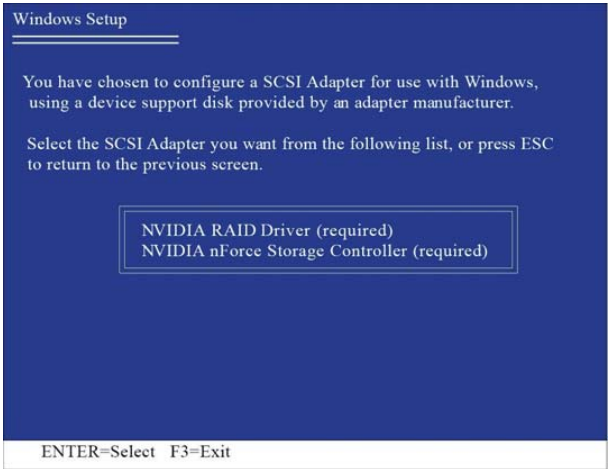

Please press “ENTER” to continue installation

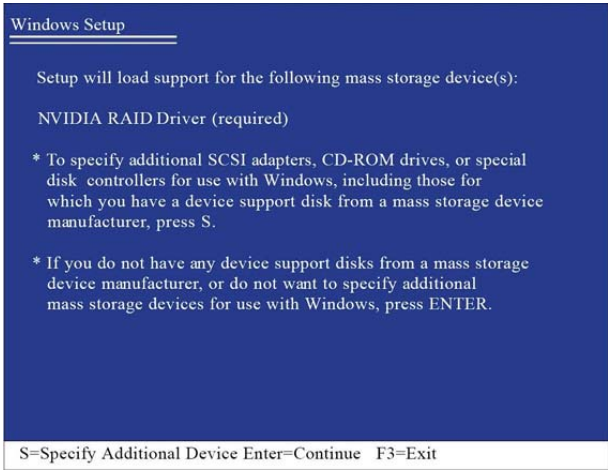

When the screen as show below appers, Press”Enter” to continue the driver insatllation from the floppy disk .

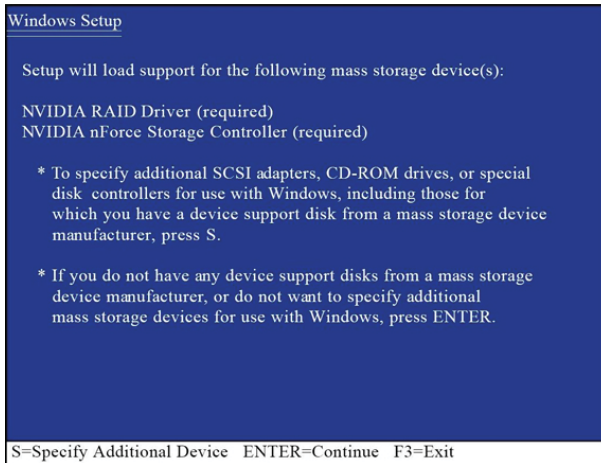

Chapter 5 Installing Drivers

5.1 Driver Install Utility



You may think that installing drivers and utilities would be a repeated task of going through these installation wizards and step-by-step. You will be surprised how using EzInstall makes it so easy. Without wizards or steps, all you have to do is to do is click and then it's done. Click and it is done. EzInstall makes installation easy and even foolproof!

After putting in the CD, you will be prompted with the AOpen welcome page and our branch information.

First, click on the install driver ICON on the left side for necessary drivers. Second, click on the install utility ICON on the left side for preferred utilities. You may also browse CD contents, and Readme to get more information, or just exit the CD installation.

- Install Driver
- Install Utility
- Browse CD Contents
- Read me
- Exit CD

AOpen

Welcome Install User manual

Thank you for choosing AOpen nMCP66ST-LA

Contact us

AOpen Inc. http://www.aopen.com TEL: +886-2-7710-1195 FAX: +886-2-7710-1187	AOpen Computer GmbH. http://www.aopen.de E-Mail: support@aopen.de
AOpen America Inc. http://usa.aopen.com TEL: +1-408-586-1201 FAX: +1-408-586-1210	AOpen Japan Inc. http://aopen.jp FAX: +81-048-288-0955
AOpen Computer B.V. http://www.aopen.nl TEL: +31-73-645-9516 FAX: +31-73-645-9604	AOpen International Co., Ltd. http://www.aopen.com.cn TEL: +86-21-6225-8622 FAX: +86-21-6225-7926

Ez Install!

5.2 Other useful Features

Press the Icon to go to the “Install Driver” page. You may press “Back” to return to the main page.

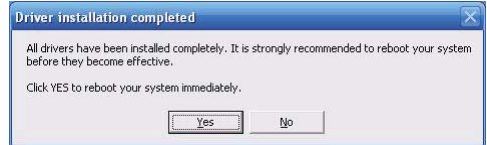

Once clicking “GO”, EzInstall will run the installing procedure automatically, and prompt a reboot dialog (Some drivers or utilities may skip the reboot part).

Note:



Due to the limitation of Intel chipsets driver, Windows 2000 is needed to be updated to service pack 4 for installing the audio driver correctly.

5.3 Useful Utilities

Installing Utilities is virtually the same as installing drivers. AOpen provides you with many friendly and powerful utilities to manage your system. You will find a lot of fabulous utilities listed here, and all you have to do is to click on “GO”, then it will install the utilities to your system right away without complicated steps.

Press the icon to go to the “Install Utilities” page for your selection. You may also press “Back” to get back to the Main page.

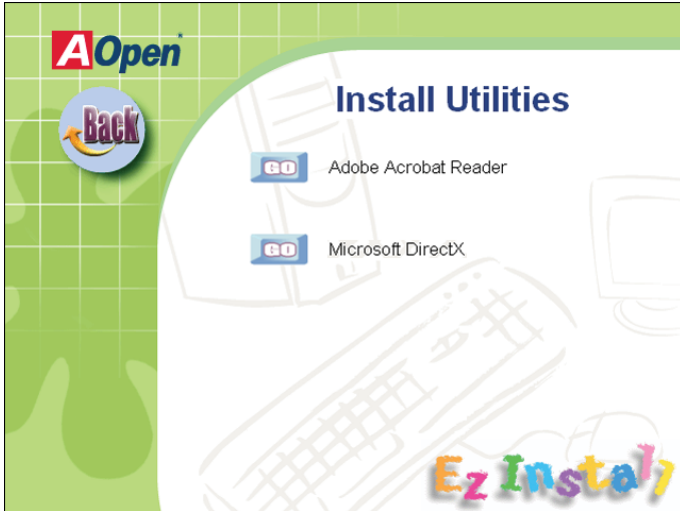

Chapter 6 Troubleshooting

6.1 Troubleshooting Steps

You are welcome to visit our technical website to learn more about these features.

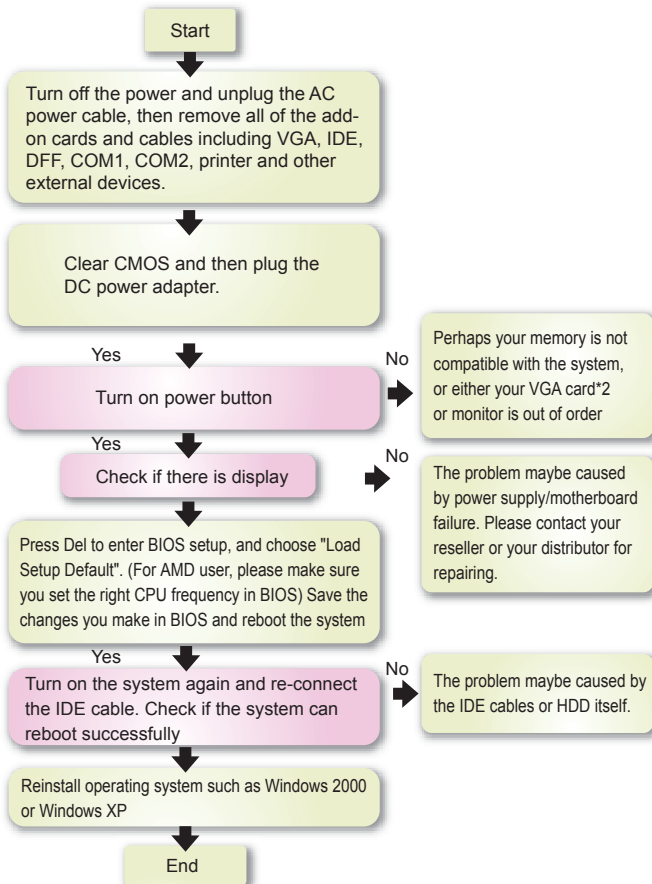

Chapter 7 Technical Support and Contact

Dear Customer,

Thanks for choosing AOpen products. We invite you to register at <http://www.aopen.com> to become a Gold Member of Club AOpen so as to ensure quality service in the future. In order to maintain the best service to every customer, we recommend you to follow the procedures below and seek help from our branches according to the region you purchased the product. With your help, we can then continue to provide efficient and high quality service to every customer.

Thank very much for your understanding!

AOpen Technical Support Team Global Locations

Europe

AOpen Computer b.v.
Email: Support@AOpen.NL

Germany

AOpen Computer GmbH.
E-mail :support@aopen.de

China

艾爾鵬國際貿易(上海)有限公司
Tel: 86-21-6225-8622
Fax: 86-21-6225-7926

Pacific Rim

AOpen Inc.
Tel: 886-2-7710-1195
Fax: 886-2-7710-1187

America

AOpen America Inc.
Tel: 1-408-586-1201
Fax: 1-408-586-1210

Japan

AOpen Japan Inc.
Fax: +81-048-288-0955



Europe Email: Support@AOpen.NL
Pacific Rim: <http://www.aopen.com.tw>
China: <http://www.aopen.com.cn>
Germany: <http://www.aopencom.de>
America: <http://usa.aopen.com>
Japan: <http://aopen.jp>

Model Name and BIOS Version

Model name and BIOS version can be found on upper left corner of first boot screen (POST screen). For example: nMCP68St-LA is model name of motherboard; R1.00 is BIOS version.

Register Your Motherboard

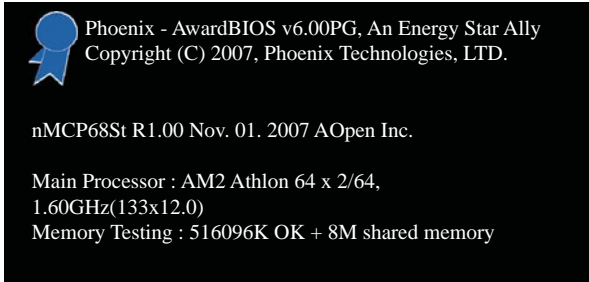

Thanks for choosing this AOpen product, please register this motherboard at <http://club.aopen.com.tw/productreg/> to become a Gold member of Club AOpen, and to ensure high service quality and priority from AOpen. You will also have a chance to play a slot machine game to win a prize from AOpen. Please prepare the following information before you start: Model Name, Part Number (P/N), Serial Number (S/N) and Purchase Date. The Part Number and Serial number are printed on the bar code label. You can find this bar code label on the outside packing or on the component side of the PCB. For example:



P/N: 91881102010 is part number, S/N: 91949378KN73 is the serial number.

Phoenix-Award BIOS ERROR Message	
Beep Sound	Message
1 short(Beep)	System booting is normally.
1 long - 1 short(Beep)	DRAM ERROR
1 long - 2 short(Beep)	Display card or monitor connected error
1 long - 3 short(Beep)	Keyboard Error
Long(Beep) continuous	DRAM hasn't inset correctly.

AOpen Technical Support

Online Manuals: To download a manual, please log on and then select your preferred language. Under “Type” directly, choose “Manuals” to go to our manual database. You can also find the manual and EIG in AOpen Bonus Pack.

<http://www.aopen.com> > Chose Territory > Download

RCL: We recommend you to choose board/ card/device from the compatibility test reports for assembling your PC. It may prevent incompatibility problems.

<http://www.aopen.com> > Chose Territory > RCL

FAQ: Here we list problems that users often encounter and FAQ (Frequently Asked Questions). You may select your preferred language after log on, and may be able to find a solution to your problem.

<http://www.aopen.com> > Chose Territory > Tech.FAQ

Download Software: After log on and selecting language, you may get the latest updated BIOS/ utility and drivers that you need under “Type” directly. In most cases, newer versions of drivers and BIOS have solved earlier bugs, or compatibility problems.

<http://www.aopen.com> > Chose Territory > Download