

FCC Information and Copyright

This equipment has been tested and found to comply with the limits of a Class B digital device, pursuant to Part 15 of the FCC Rules. These limits are designed to provide reasonable protection against harmful interference in a residential installation. This equipment generates, uses and can radiate radio frequency energy and, if not installed and used in accordance with the instructions, may cause harmful interference to radio communications. There is no guarantee that interference will not occur in a particular installation.

The vendor makes no representations or warranties with respect to the contents here and specially disclaims any implied warranties of merchantability or fitness for any purpose. Further the vendor reserves the right to revise this publication and to make changes to the contents here without obligation to notify any party beforehand.

Duplication of this publication, in part or in whole, is not allowed without first obtaining the vendor's approval in writing.

The content of this user's manual is subject to be changed without notice and we will not be responsible for any mistakes found in this user's manual. All the brand and product names are trademarks of their respective companies.

Table of Contents

Chapter 1: Introduction	1
1.1 Motherboard Features	1
1.2 Package Checklist.....	6
1.3 Layout & Components.....	7
Chapter 2: Hardware Installation	8
2.1 Central Processing Unit (CPU).....	8
2.2 Fan Headers.....	10
2.3 Memory Modules Installation	11
2.4 Connectors, & Slots	12
Chapter 3: Headers & Jumpers Setup.....	13
3.1 How to setup Jumpers	13
3.2 Detail Settings.....	13
Chapter 4: Useful Help.....	19
4.1 Award BIOS Beep Code.....	19
4.2 Troubleshooting.....	19
Chapter 5: NVIDIA RAID Functions	20
5.1 Operation System.....	20
5.2 Raid Arrays	20
5.3 How RAID Works.....	21
Chapter 6: WarpSpeeder™	25
6.1 Introduction.....	25
6.2 System Requirement.....	25
6.3 Installation.....	26
6.4 [WarpSpeeder™] includes 1 tray icon and 5 panels.....	27

CHAPTER 1: INTRODUCTION

1.1 MOTHERBOARD FEATURES

A. Hardware

CPU

- Supports Socket 939.
- Supports AMD Athlon 64 FX processor.
- Supports AMD Athlon 64 processor.
- Supports AMD Sempron processor.
- AMD 64 architecture enables simultaneous 32 and 64 bit computing.
- Supports HyperTransport Technology.
- Supports AMD Cool'n'Quiet Technology.

Chipset

- NVIDIA nForce4 CK8-04 Ultra:
 - Supports NVIDIA Firewall.
 - Supports Gigabit Ethernet.
 - Supports 10 USB 2.0 ports.
 - Supports NVIDIA nTune Utility.
 - Supports NVIDIA Secure Networking Processor.
 - Supports 4 SATA ports, each channel up to 3Gb/s.
 - Supports 1 PCI-Express x16 interface graphics slot.
 - Supports NVIDIA RAID functions, including RAID 0, RAID 1 and RAID 0+1.
 - Supports 4 IDE disk drives with PIO Mode 5, Biide Mode and Ultra DMA 33/66/100/133 Bus Master Mode.
 - Compliant with AC'97 version 2.3 specification.
 - Compliant with PCI-Express Version 1.1a specification.

Operating Systems

- Supports Windows 2000 and Windows XP.
Note: Do not support Windows 98SE and Windows ME.
- Supports SCO UNIX.

NF4 Ultra-A9

Dimensions

- ATX Form Factor: 23.4cm (W) x 29.35cm (L)

Main Memory

- Supports Dual Channel DDR.
- Supports 8 banks in total.
- Supports DDR333 and DDR400.
- Maximum memory size is 4GB.

DIMM Socket Location	DDR Module	Total Memory Size (MB)
DIMM1	128MB/256MB/512MB/1GB *1	Max is 4 GB.
DIMM2	128MB/256MB/512MB/1GB *1	
DIMM3	128MB/256MB/512MB/1GB *1	
DIMM4	128MB/256MB/512MB/1GB *1	

DDR Installation Notice:

- Please follow the table below to install your DDR memory module, or the system may not boot up or may not function properly.
- “SS” represents Single Side DDR memory module.
- “DS” represents Double Side DDR memory module.
- Star sign “*” represents leave the DIMM socket empty.

DIMM1	SS/DS	*	SS/DS	SS/DS
DIMM2	*	*	*	SS/DS
DIMM3	*	SS/DS	SS/DS	SS/DS
DIMM4	*	*	*	SS/DS

On-board IDE

- 2 on-board connectors support 4 IDE disk drives.
- Supports PIO mode 5, Block Mode and Ultra DMA 33/66/100/133 bus master mode.

Serial ATA

- 4 on-board Serial ATA connectors support 4 serial ATA (SATA) ports.
- Compliant with SATA2.0 specification.
- Data transfer rates up to 3Gb/s.

NF4 Ultra-A9

Slots

- Three 32bit PCI bus master slots.
- Two PCI-Express x1 slots:
 - PCI Express 1.0a compliant.
 - Bandwidth 250MB/s per direction.
- One PCI-Express x16 slot.
 - PCI Express 1.0a compliant.
 - Maximum theoretical realized bandwidth of 4GB/s simultaneously per direction, for an aggregate of 8GB/s totally.
- One Xtreme Graphics Port slot. (See p.12 for detail information)

Super I/O

- Chip: ITE IT8712F.
- Low Pin Count Interface.
- Provides the most commonly used legacy Super I/O functionality.
- Environment Control initiatives,
 - H/W Monitor
 - Fan Speed Controller
 - ITE's "Smart Guardian" function

On-board AC'97 Audio Sound Codec

- Chip: ALC850:
 - Compliant with AC'97 version 2.3 specification.
 - Supports 8 channels audio output
- Chip: ALC655 (optional):
 - Compliant with AC'97 version 2.3 specification.
 - Supports 6 channels audio output.

IEEE 1394A Chip (optional)

- Chip: VIA VT6307.
- Supports 2 ports with transfer up to 400Mb/s.

NF4 Ultra-A9

Gigabit Ethernet LAN

- NVIDIA Gigabit MAC + VITESSE Gigabit PHY VSC8201.
- Supports 10 Mb/s, 100 Mb/s and 1Gb/s auto-negotiation.
- Half/Full duplex capability.
- Supports personal Firewall setup.
- Supports ACPI power management.
- Supports NVIDIA StreamThru technology
 - Isochronous controller paired with HyperTransport results in fastest networking performance

Security

- NVIDIA Networking Processor.
- NVIDIA Firewall technology
 - Native firewall solution, protects the PC from intruders by filtering unauthorized traffic.
- Advanced features
 - Remote access, configuration, monitoring
 - Command line interface (CLI)
 - WMI scripts.
- NVIDIA Active Armor
 - Enhance network security, and providing users an environment with both fast and secure.

Storage

- NVIDIA RAID Technology
 - RAID 0 disk striping for highest system and application performance
 - RAID 1 disk mirroring support for fault tolerance
Support for both SATA and ATA-133 disk controller standards
 - RAID 0+1 disk striping and mirroring for highest performance with fault tolerance

NF4 Ultra-A9

Internal On-board Connectors and Headers

- 1 audio-out header supports audio-out facilities.
- 1 front panel header supports front panel facilities.
- 1 CD-in connector supports CD-ROM audio-in function.
- 1 SPDIF-out connector supports digital audio-out function.
- 1 SPDIF-in connector supports digital audio-in function (optional).
- 1 IEEE1394 header supports 1 1394 Firewire port (optional).
- 1 floppy connector supports 2 FDD devices with 360K, 720K, 1.2M, 1.44M and 2.88Mbytes.
- 2 IDE connectors support 4 IDE disk drives.
- 3 USB headers support 6 USB 2.0 ports at front panel.
- 4 Serial ATA connectors support 4 SATA devices.

Rear (Back Panel) Side Connectors

- 1 PS/2 Mouse Port.
- 1 PS/2 Keyboard Port.
- 1 Printer Port.
- 1 Serial Port. (COM2 is optional.)
- 1 1394 Firewire Port (optional).
- 1 RJ-45 LAN jack.
- 4 USB 2.0 Ports.
- 6 audio ports support 8 channels audio-out facilities (with ALC850).

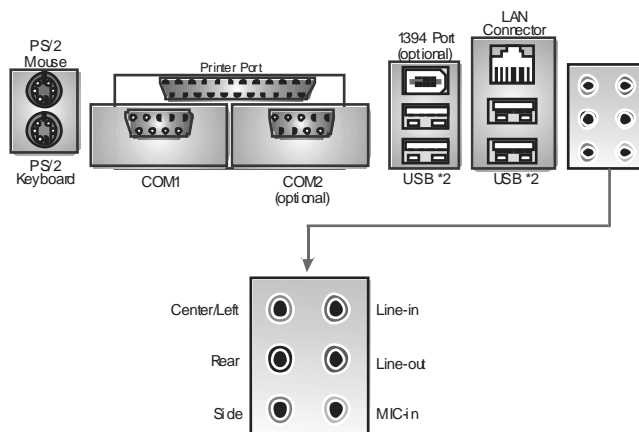

NF4 Ultra-A9

- 3 audio ports support 6 channels audio-out facilities (with ALC655, optional).

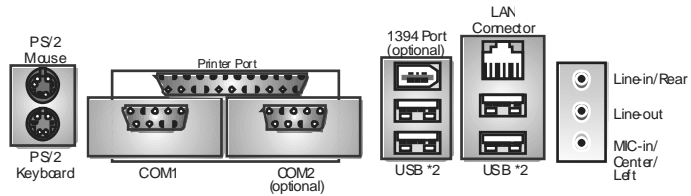

B. BIOS & Software

BIOS

- Award legal BIOS.
- Supports APM1.2.
- Supports ACPI.
- Supports USB Function.

Bundled Software

- Supports 9th Touch™, WINFLASHER™ and FLASHER™.

1.2 PACKAGE CHECKLIST

- FDD Cable x 1
- HDD Cable x 1
- User's Manual x 1
- Serial ATA Cable x 1
- Fully Setup Driver CD x 1
- Rear I/O Panel for ATX Case x 1
- S/PDIF Cable x 1 (optional)
- USB 2.0 Cable x 1 (optional)
- IEEE 1394 Cable x 1 (optional)
- Serial ATA Power Switch Cable x 1 (optional)

NF4 Ultra-A9

1.3 LAYOUT & COMPONENTS

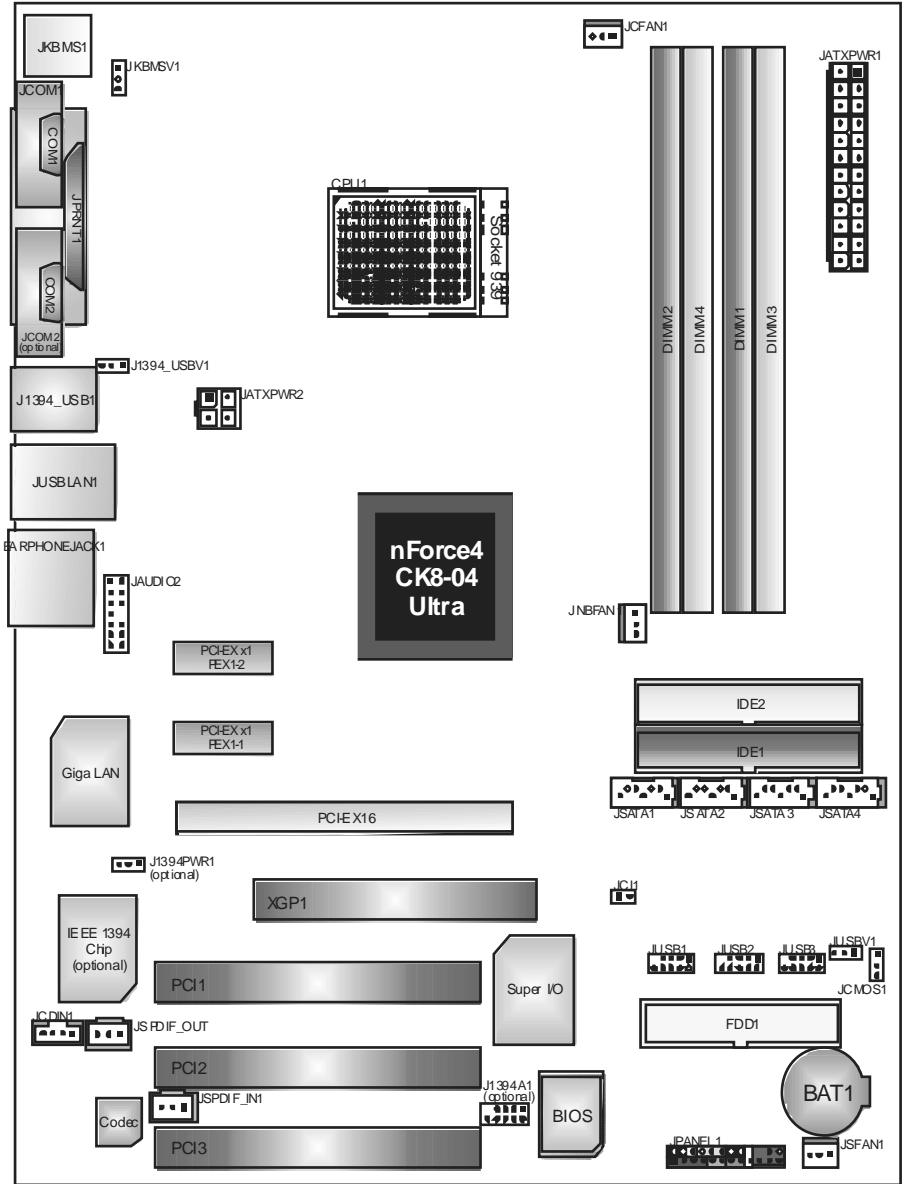

Note: ■ represents the 1st pin.

CHAPTER 2: HARDWARE INSTALLATION

2.1 CENTRAL PROCESSING UNIT (CPU)

Step 1: Remove the socket protection cap.

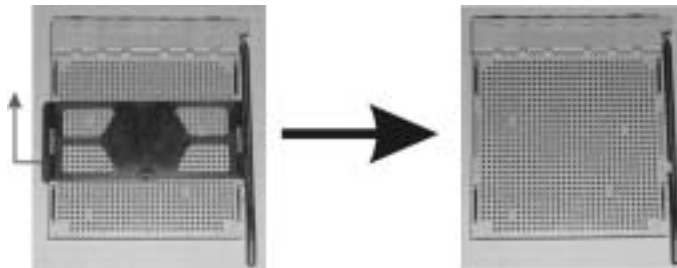
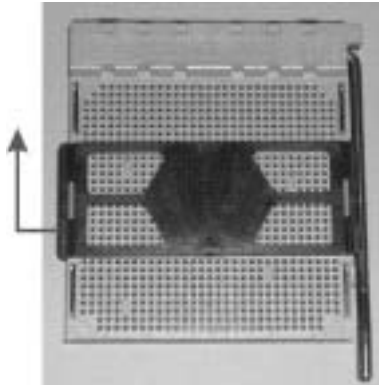

Step 2: Pull the lever sideways away from the socket and then raise the lever up to a 90-degree angle.

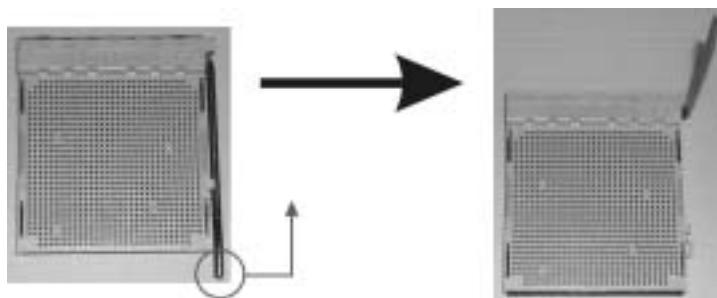

NF4 Ultra-A9

Step 3: Look for the black cut edge on socket, and the white dot on CPU should point forwards this black cut edge. The CPU will fit only in the correct orientation.

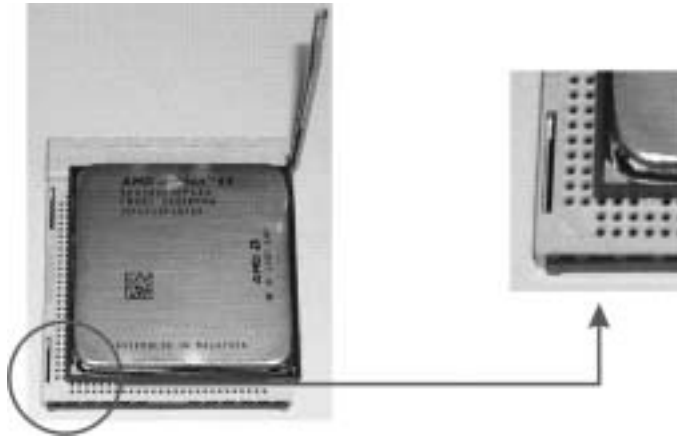

Step 4: Hold the CPU down firmly, and then close the lever to complete the installation.

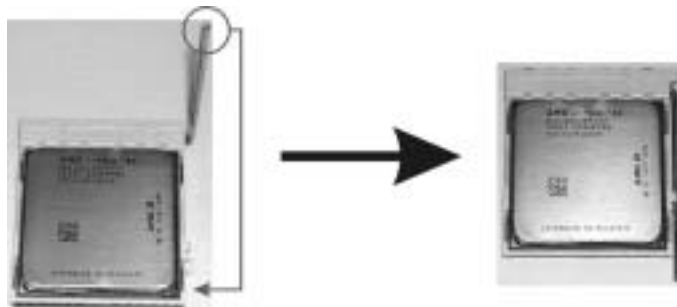

Step 5: Put the CPU Fan on the CPU and buckle it. Connect the CPU FAN power cable to the JCFAN1. This completes the installation.

NF4 Ultra-A9

2.2 FAN HEADERS

CPU FAN Power Header: JCFAN1

	Pin	Assignment
	1	Ground
	2	+12V
	3	FAN RPM rate sense

System Fan Power Header: JSFAN1

	Pin	Assignment
	1	Ground
	2	+12V
	3	FAN RPM rate sense

North Bridge Fan Power Header: JNBFAN1

	Pin	Assignment
	1	Ground
	2	+12V
	3	FAN RPM rate sense

Note:

The JCFAN1, JSFAN1 and JNBFAN1 support system cooling fan with Smart Fan Control utility. It supports 3 pin head connector. When connecting with wires onto connectors, please note that the red wire is the positive and should be connected to pin#2, and the black wire is Ground and should be connected to GND.

NF4 Ultra-A9

2.3 MEMORY MODULES INSTALLATION

2.2.1 DDR Module installation

1. Unlock a DIMM slot by pressing the retaining clips outward. Align a DIMM on the slot such that the notch on the DIMM matches the break on the Slot.

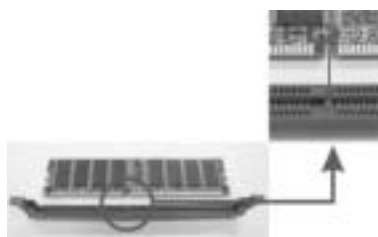

2. Insert the DIMM vertically and firmly into the slot until the retaining chip snap back in place and the DIMM is properly seated.

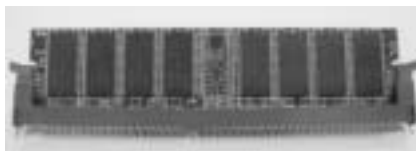

NF4 Ultra-A9

2.4 CONNECTORS, & SLOTS

Floppy Disk Connector: FDD1

The motherboard provides a standard floppy disk connector that supports 360K, 720K, 1.2M, 1.44M and 2.88M floppy disk types. This connector supports the provided floppy drive ribbon cables.

Hard Disk Connectors: IDE1/IDE2

The motherboard has a 32-bit Enhanced PCI IDE Controller that provides PIO Mode 0~5, Bus Master, and Ultra DMA 33/66/100/133 functionality. It has two HDD connectors IDE1 (primary) and IDE2 (secondary).

The IDE connectors can connect a master and a slave drive, so you can connect up to four hard disk drives. The first hard drive should always be connected to IDE1.

Peripheral Component Interconnect Slots: PCI1~PCI3

This motherboard is equipped with 3 standard PCI slot. PCI stands for Peripheral Component Interconnect, and it is a bus standard for expansion cards. This PCI slot is designated as 32 bits.

Xtreme Graphics Port Slot: XGP1

This XGP (Xtreme Graphics Port) slot is a special design that only supports compatible AGP VGA cards.

To install the system with an add-on AGP VGA card, please make sure to install the driver of add-on AGP VGA card before onboard VGA driver installation. If the onboard VGA driver has already been installed before you install the add-on AGP VGA card, the system will automatically set the onboard VGA as the primary graphics adapter.

For the onboard VGA driver can't be removed completely, and to solve this problem, please follow the steps below,

1. Disable onboard VGA utility under the operating system, and reboot PC. After PC restarts, the system will automatically set the AGP VGA card as the graphics adapter.
2. Re-install your operating system to ensure the AGP VGA card function can be used.

Note:

Please go to "<http://www.biostar.com.tw>" for more detailed information about XGP compatible AGP cards.

CHAPTER 3: HEADERS & JUMPERS SETUP

3.1 HOW TO SETUP JUMPERS

The illustration shows how to set up jumpers. When the jumper cap is placed on pins, the jumper is “close”, if not, that means the jumper is “open”.



Pin opened



Pin dosed



Pin1-2 dosed

3.2 DETAIL SETTINGS

ATX Power Source Connectors: JATXPWR1/JATXPWR2



JATXPWR1: This connector allows user to connect 20-pin power connector on the ATX power supply.

JATXPWR2: By connecting this connector, it will provide +12V to CPU power circuit.

<p>JATXPWR1</p>	Pin	Assignment	Pin	Assignment
	1	+3.3V	13	+3.3V
	2	+3.3V	14	-12V
	3	Ground	15	Ground
	4	+5V	16	PS_ON
	5	Ground	17	Ground
	6	+5V	18	Ground
	7	Ground	19	Ground
	8	PW_OK	20	-5V
	9	Standby Voltage +5V	21	+5V
	10	+12V	22	+5V
	11	+12V	23	+5V
12	Detect	24	Ground	
<p>JATXPWR2</p>	Pin	Assignment	Pin	Assignment
	1	+12V	3	Ground
	2	+12V	4	Ground

NF4 Ultra-A9



Power Source Headers for USB Ports: J1394_USBV1/JUSBV1

	Assignment	Description
 <p>Pin 1-2 close</p>	+5V	J1394_USBV1: +5V for USB ports at J1394_USB1 and JUSBLAN1. JUSBV1: +5V for front USB headers (JUSB1/JUSB2/JUSB3).
 <p>Pin 2-3 close</p>	+5V standby Voltage	J1394_USBV1: USB ports at J1394_USB1 and JUSBLAN1 are powered with +5V standby voltage. JUSBV1: Front USB headers (JUSB1/JUSB2/JUSB3) are powered with +5V standby voltage.

Note:

In order to support this function “Power-on system via USB device,” “J1394_USBV1/JUSBV1” jumper cap should be placed on Pin 2-3 individually.

Power Source Header for PS/2 Keyboard/Mouse: JKBMSV1

	Assignment	Description
 <p>Pin 1-2 close</p>	+5V	+5V for key board and mouse
 <p>Pin 2-3 close</p>	+5V Standby Voltage	PS/2 keyboard and mouse are powered with +5V standby voltage.

Note:

In order to support this function “Power-on system via keyboard and mouse”, “JKBMSV1” jumper cap should be placed on Pin 2-3.

CD-ROM Audio-in Connector: JCDIN1

This connector allows user to connect the audio source from the variety devices, like CD-ROM, DVD-ROM, PCI sound card, PCI TV turner card etc..

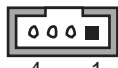
 <p>JCDIN1</p>	Pin	Assignment
	1	Left channel input
	2	Ground
	3	Ground
	4	Right channel input

NF4 Ultra-A9

Front Panel Audio-out Header: JAUDIO2

This connector will allow user to connect with the front audio out put headers on the PC case. It will disable the output on back panel audio connectors.

With ALC850 Audio Sound Codec:

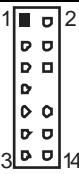
			
Pin	Assignment	Pin	Assignment
1	Mic in/Stereo MIC-in R.	2	Ground
3	Stereo MIC-in L	4	Audio power
5	Right line out/Speaker out Right	6	Right line out/Speaker out Right
7	Reserved	8	Key
9	Left line out/Speaker out Left	10	Left line out/Speaker out Left
11	Right line in	12	Right line in
13	Left line in	14	Left line in

With ALC655 Audio Sound Codec (optional):

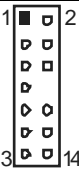
			
Pin	Assignment	Pin	Assignment
1	Stereo MIC-in R/ Center	2	Ground
3	Stereo MIC-in L/ Bass	4	Audio power
5	Right line out/Speaker-out Right	6	Right line out/Speaker-out Right
7	Reserved	8	Key
9	Left line out/Speaker-out Left	10	Left line out/Speaker out Left
11	Right line in/Rear speaker Right	12	Right line in/Rear speaker Right
13	Left line in/Rear speaker Left	14	Left line in/Rear speaker Left

NF4 Ultra-A9

Digital Audio-out Connector: JSPDIF_OUT

This connector will allow user to connect the PCI bracket SPDIF output header.

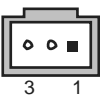

 <p style="text-align: center;">JSPDIF_OUT</p>	Pin	Assignment
	1	+5V
	2	SPDIF OUT
	3	Ground

Digital Audio-in Connector: JSPDIF_IN1 (optional)

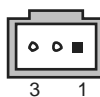
This connector will allow user to connect the PCI bracket SPDIF output header.

 <p style="text-align: center;">JSPDIF_IN1</p>	Pin	Assignment
	1	+5V
	2	SPDIF In
	3	Ground

Power Source Header for 1394 Chip: J1394PWR1 (optional)

	Assignment	Description
 <p>Pin 1-2 close</p>	+3.3V	+3.3V for 1394 chipset. (Default)
 <p>Pin 2-3 close</p>	+3.3V SB	+3.3V SB for 1394 chipset.

Header for 1394 Fire wire Port at Front Panel: J1394A1 (optional)

This connector allows user to connect the front 1394 port for digital image devices.

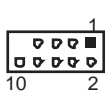
	Pin	Assignment	Pin	Assignment
	1	A+	2	A-
	3	Ground	4	Ground
	5	B+	6	B-
	7	+12v	8	+12V
	9	Key	10	Ground

NF4 Ultra-A9

Header for Front Panel Facilities: JPANEL1

This 24-pin connector includes Power-on, Reset, HDD LED, Power LED, Sleep button, speaker and IrDA Connection. It allows user to connect the PC case's front panel switch functions.

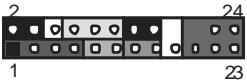
					
Pin	Assignment	Function	Pin	Assignment	Function
1	+5V	Speaker Connector	2	Sleep control	Sleep button
3	N/A		4	Ground	
5	N/A		6	N/A	N/A
7	Speaker	Hard drive LED	8	Power LED (+)	Power LED
9	HDD LED (+)		10	Power LED (+)	
11	HDD LED (-)		12	Power LED (-)	
13	Ground	Reset button	14	Power button	Power-on button
15	Reset control		16	Ground	
17	N/A		18	Key	
19	N/A	IrDA Connector	20	Key	IrDA Connector
21	+5V		22	Ground	
23	IRTX		24	IRRX	

Headers for USB Ports at Front Panel: JUSB1~JUSB3

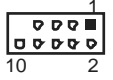

This connector allows user to connect additional USB cables at PC front panel, and also can be connected with internal USB devices, like USB card reader.

			
Pin	Assignment	Pin	Assignment
1	+5V (f used)	2	+5V (f used)
3	USB-	4	USB-
5	USB+	6	USB+
7	Ground	8	Ground
9	Key	10	NC

NF4 Ultra-A9

Close CMOS Header: JCMOS1

By placing the jumper on pin2-3, it allows user to restore the BIOS safe setting and the CMOS data, please carefully follow the procedures to avoid damaging the motherboard.

JCMOS1	Assignment
 <p>Pin 1-2 close</p>	Normal Operation (Default).
 <p>Pin 2-3 close</p>	Clear CMOS data.

※ Clear CMOS Procedures:

1. Remove AC power line.
2. Set the jumper to "Pin 2-3 close".
3. Wait for five seconds.
4. Set the jumper to "Pin 1-2 close".
5. Power on the AC.
6. Reset your desired password or clear the CMOS data.

Case Open Header: JC11

This connector allows system to monitor PC case open status. If the signal has been triggered, it will record to the CMOS and show the message on next boot-up.

	Pin	Assignment
	1	Case open signal
2	Ground	

Serial ATA Connector: JSATA1~JSATA4

The motherboard has a SATA Controller in nForce4 (CK8-04) with 4 channels SATA interface, it satisfies the SATA 1.0 spec and with transfer rate of 1.5Gb/s.

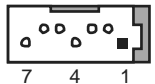
	Pin	Assignment	Pin	Assignment
	1	Ground	2	TX+
3	TX-	4	Ground	
5	RX-	6	RX+	
7	Ground			

CHAPTER 4: USEFUL HELP

4.1 AWARD BIOS BEEP CODE

Beep Sound	Meaning
One long beep followed by two short beeps	Video card not found or video card memory bad
High-low siren sound	CPU overheated System will shut down automatically
One Short beep when system boot-up	No error found during POST
Long beeps every other second	No DRAM detected or install

4.2 TROUBLESHOOTING

Probable	Solution
<ol style="list-style-type: none"> 1. No power to the system at all. Power light don't illuminate, fan inside power supply does not turn on. 2. Indicator light on key board does not turn on. 	<ol style="list-style-type: none"> 1. Make sure power cable is securely plugged in. 2. Replace cable. 3. Contact technical support.
System inoperative. Keyboard lights are on, power indicator lights are lit, and hard drive is spinning.	Using even pressure on both ends of the DIMM, press down firmly until the module snaps into place.
System does not boot from hard disk drive, can be booted from optical drive.	<ol style="list-style-type: none"> 1. Check cable running from disk to disk controller board. Make sure both ends are securely plugged in. check the drive type in the standard CMOS setup. 2. Backing up the hard drive is extremely important. All hard disks are capable of breaking down at any time.
System only boots from optical drive. Hard disk can be read and applications can be used but booting from hard disk is impossible.	Back up data and applications files. Reformat the hard drive. Re-install applications and data using backup disks.
Screen message says "Invalid Configuration" or "CMOS Failure."	Review system's equipment. Make sure correct information is in setup.
Cannot boot system after installing second hard drive.	Set master/slave jumpers correctly. Run SETUP program and select correct drive types. Call the drive manufacturer for compatibility with other drives.

CHAPTER 5: NVIDIA RAID FUNCTIONS

5.1 OPERATION SYSTEM

- Windows XP home Edition
- Windows XP Professional Edition
- Windows 2000 Professional

5.2 RAID ARRAYS

NVRAID supports the following types of RAID arrays:

RAID 0:

RAID 0 defines a disk striping scheme that improves disk read and writes times for many applications.

RAID 1:

RAID 1 defines techniques for mirroring data.

RAID 0+1:

RAID 0+1 combines the techniques used in RAID 0 and RAID 1.

Spanning (JBOD):

JBOD provides a method for combining drives of different sizes in to one large disk.

5.3 HOW RAID WORKS

RAID 0:

The controller “stripes” data across multiple drives in a RAID 0 array system. It breaks up a large file into smaller blocks and performs disk reads and writes across multiple drives in parallel. The size of each block is determined by the strip size parameter, which you set during the creation of the RAID set based on the system environment.

This technique reduces overall disk access time and offers high bandwidth.

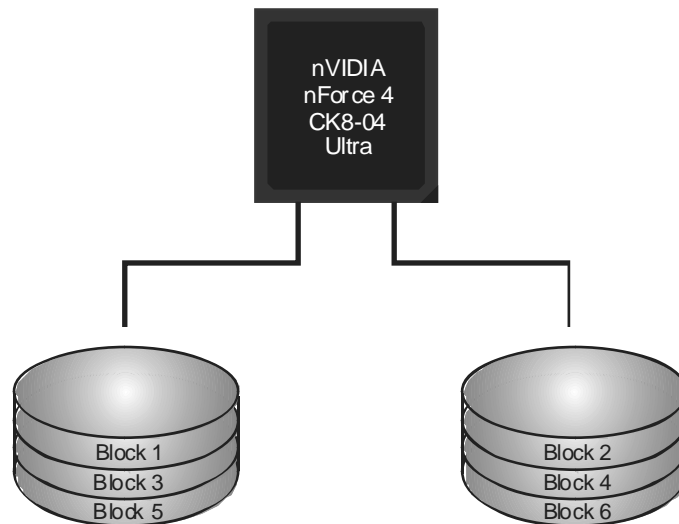

Features and Benefits

- **Drives:** Minimum 1, and maximum is up to 6 or 8. Depending on the platform.
- **Uses:** Intended for non-critical data requiring high data throughput, or any environment that does not require fault tolerance.
- **Benefits:** provides increased data throughput, especially for large files. No capacity loss penalty for parity.
- **Drawbacks:** Does not deliver any fault tolerance. If any drive in the array fails, all data is lost.
- **Fault Tolerance:** No.

NF4 Ultra-A9

RAID 1:

Every read and write is actually carried out in parallel across 2 disk drives in a RAID 1 array system. The mirrored (backup) copy of the data can reside on the same disk or on a second redundant drive in the array. RAID 1 provides a hot-standby copy of data if the active volume or drive is corrupted or becomes unavailable because of a hardware failure.

RAID techniques can be applied for high-availability solutions, or as a form of automatic backup that eliminates tedious manual backups to more expensive and less reliable media.

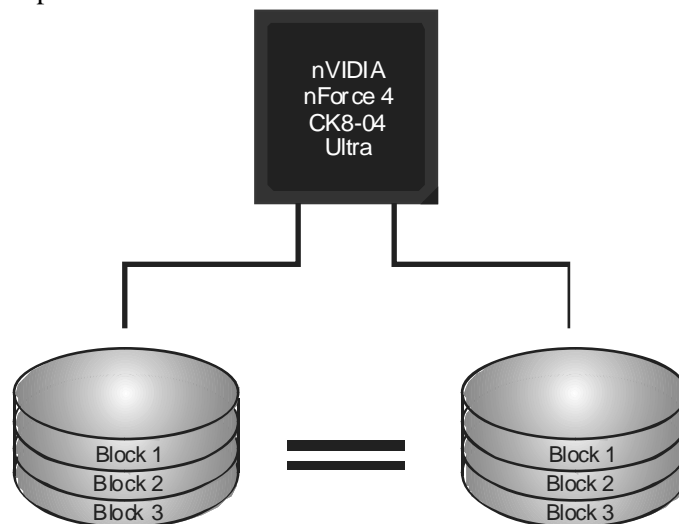

Features and Benefits

- **Drives:** Minimum 2, and maximum is 2.
- **Uses:** RAID 1 is ideal for small databases or any other application that requires fault tolerance and minimal capacity.
- **Benefits:** Provides 100% data redundancy. Should one drive fail, the controller switches to the other drive.
- **Drawbacks:** Requires 2 drives for the storage space of one drive. Performance is impaired during drive rebuilds.
- **Fault Tolerance:** Yes.

NF4 Ultra-A9

RAID 0+1:

RAID 0 drives can be mirrored using RAID 1 techniques. Resulting in a RAID 0+1 solution for improved performance plus resiliency.

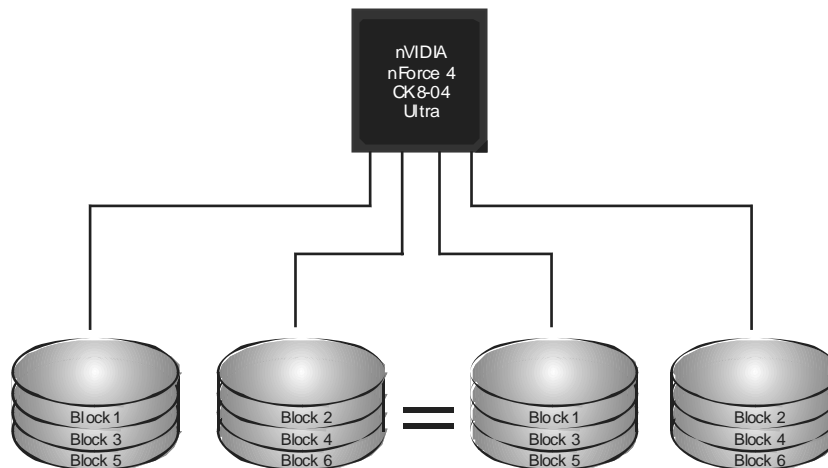

Features and Benefits

- **Drives:** Minimum 4, and maximum is 6 or 8, depending on the platform.
- **Benefits:** Optimizes for both fault tolerance and performance, allowing for automatic redundancy. May be simultaneously used with other RAID levels in an array, and allows for spare disks.
- **Drawbacks:** Requires twice the available disk space for data redundancy, the same as RAID level 1.
- **Fault Tolerance:** Yes.

NF4 Ultra-A9

Spanning (JBOD):

JBOD stands for “Just a Bunch of Disks”. Each drive is accessed as if it were on a standard SCSI host bus adapter. This is useful when a single drive configuration is needed, but it offers no speed improvement or fault tolerance.

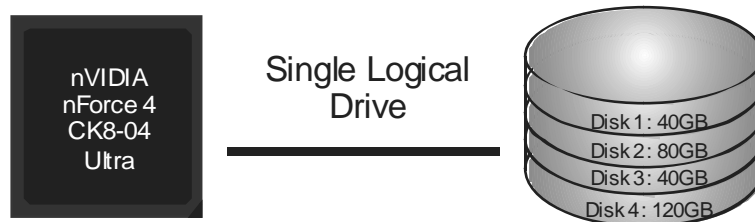

Features and Benefits

- **Uses:** JBOD works best if you have odd sized drives and you want to combine them to make one big drive.
- **Benefits:** JBOD provides the ability to combine odd size drives using all of the capacity of the drives.
- **Drawbacks:** Decreases performance because of the difficulty in using drives concurrently.
- **Fault Tolerance:** Yes.

※ For more detailed setup information, please refer to the Driver CD, or go to http://www.nvidia.com/page/pg_20011106217193.html to download NVIDIA nForce Tutorial Flash.

CHAPTER 6: WARPSPEEDER™



6.1 INTRODUCTION

[WarpSpeeder™], a new powerful control utility, features three user-friendly functions including Overclock Manager, Overvoltage Manager, and Hardware Monitor.

With the Overclock Manager, users can easily adjust the frequency they prefer or they can get the best CPU performance with just one click. The Overvoltage Manager, on the other hand, helps to power up CPU core voltage and Memory voltage. The cool Hardware Monitor smartly indicates the temperatures, voltage and CPU fan speed as well as the chipset information. Also, in the About panel, you can get detail descriptions about BIOS model and chipsets. In addition, the frequency status of CPU, memory, AGP and PCI along with the CPU speed are synchronically shown on our main panel.

Moreover, to protect users' computer systems if the setting is not appropriate when testing and results in system fail or hang, [WarpSpeeder™] technology assures the system stability by automatically rebooting the computer and then restart to a speed that is either the original system speed or a suitable one.

6.2 SYSTEM REQUIREMENT

OS Support: Windows 98 SE, Windows Me, Windows 2000, Windows XP
DirectX: DirectX 8.1 or above. (The Windows XP operating system includes DirectX 8.1. If you use Windows XP, you do not need to install DirectX 8.1.)

6.3 INSTALLATION

1. Execute the setup execution file, and then the following dialog will pop up. Please click “Next” button and follow the default procedure to install.

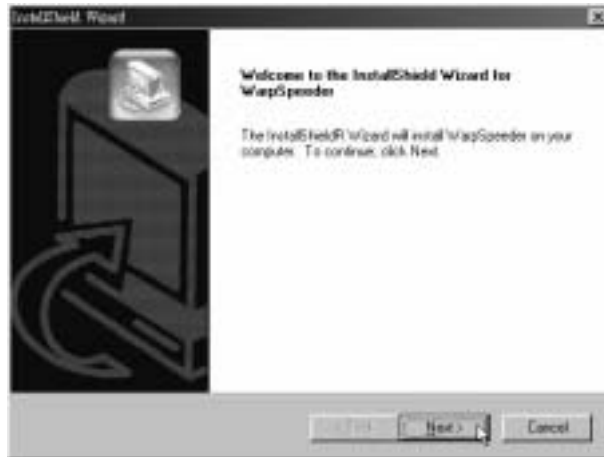

2. When you see the following dialog in setup procedure, it means setup is completed. If the “Launch the WarpSpeeder Tray Utility” checkbox is checked, the Tray Icon utility and [WarpSpeeder™] utility will be automatically and immediately launched after you click “Finish” button.



Usage:

The following figures are just only for reference, the screen printed in this user manual will change according to your motherboard on hand.

6.4 [WARPSPEEDER™] INCLUDES 1 TRAY ICON AND 5 PANELS

1. Tray Icon:

Whenever the Tray Icon utility is launched, it will display a little tray icon on the right side of Windows Taskbar.



This utility is responsible for conveniently invoking [WarpSpeeder™] Utility. You can use the mouse by clicking the left button in order to invoke [WarpSpeeder™] directly from the little tray icon or you can right-click the little tray icon to pop up a popup menu as following figure. The “Launch Utility” item in the popup menu has the same function as mouse left-click on tray icon and “Exit” item will close Tray Icon utility if selected.



NF4 Ultra-A9

2. Main Panel

If you click the tray icon, [WarpSpeeder™] utility will be invoked. Please refer to the following figure; the utility's first window you will see is Main Panel.

Main Panel contains features as follows:

- Display the CPU Speed, CPU external clock, Memory dock, AGP dock, and PCI dock information.
- Contains About, Voltage, Overclock, and Hardware Monitor Buttons for invoking respective panels.
- With a user-friendly Status Animation, it can represent 3 overclock percentage stages:

Man walking → overclock percentage from 100% ~ 110 %

Panther running → overclock percentage from 110% ~ 120%

Car racing → overclock percentage from 120% ~ above

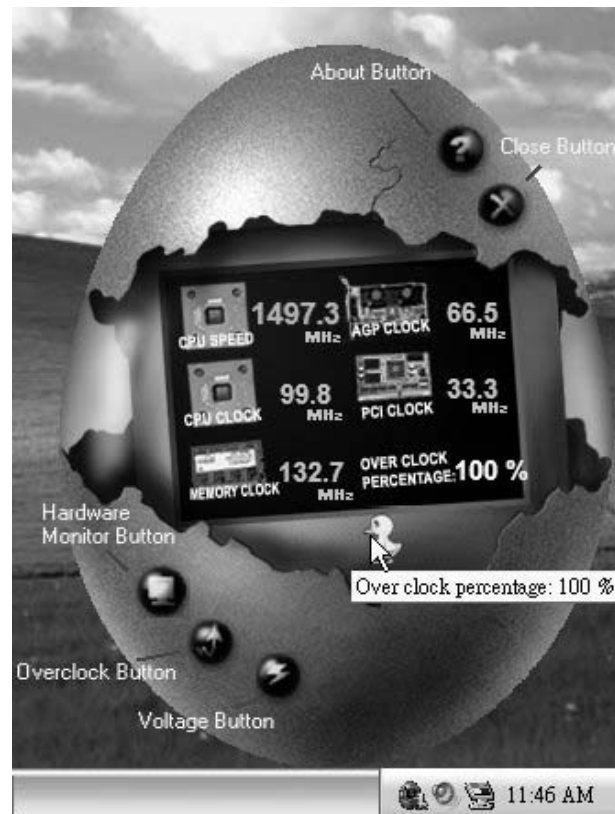

3. Voltage Panel

Click the Voltage button in Main Panel, the button will be highlighted and the Voltage Panel will slide out to up as the following figure.

In this panel, you can decide to increase CPU core voltage and Memory voltage or not. The default setting is “No”. If you want to get the best performance of overlocking, we recommend you dick the option “Yes”.



4. Overclock Panel

Click the Overclock button in Main Panel, the button will be highlighted and the Overclock Panel will slide out to left as the following figure.



Overclock Panel contains the these features:

- a. “-3MHz button”, “-1MHz button”, “+1MHz button”, and “+3MHz button”: provide user the ability to do real-time overclock adjustment.

Warning:

Manually overclock is potentially dangerous, especially when the overlocking percentage is over 110 %. We strongly recommend you verify every speed you overclock by click the Verify button. Or, you can just click Auto overclock button and let [WarpSpeeder™] automatically gets the best result for you.

- b. “Recovery Dialog button”: Pop up the following dialog. Let user select a restoring way if system need to do a fail-safe reboot.



NF4 Ultra-A9

- c. "Auto-overclock button": User can click this button and [WarpSpeeder™] will set the best and stable performance and frequency automatically. [WarpSpeeder™] utility will execute a series of testing until system fail. Then system will do fail-safe reboot by using Watchdog function. After reboot, the [WarpSpeeder™] utility will restore to the hardware default setting or load the verified best and stable frequency according to the Recovery Dialog's setting.
- d. "Verify button": User can click this button and [WarpSpeeder™] will proceed a testing for current frequency. If the testing is ok, then the current frequency will be saved into system registry. If the testing fail, system will do a fail-safe rebooting. After reboot, the [WarpSpeeder™] utility will restore to the hardware default setting or load the verified best and stable frequency according to the Recovery Dialog's setting.

Note:

Because the testing programs, invoked in Auto-overclock and Verify, include DirectDraw, Direct3D and DirectShow tests, the DirectX 8.1 or newer runtime library is required. And please make sure your display card's color depth is High color (16 bit) or True color (24/32 bit) that is required for Direct3D rendering.

5. Hardware Monitor Panel

Click the Hardware Monitor button in Main Panel, the button will be highlighted and the Hardware Monitor panel will slide out to left as the following figure.

In this panel, you can get the real-time status information of your system. The information will be refreshed every 1 second.



NF4 Ultra-A9

6. About Panel

Click the “about” button in Main Panel, the button will be highlighted and the About Panel will slide out to up as the following figure.

In this panel, you can get model name and detail information in hints of all the chipset that are related to overclocking. You can also get the mainboard’s BIOS model and the Version number of [WarpSpeeder™] utility.

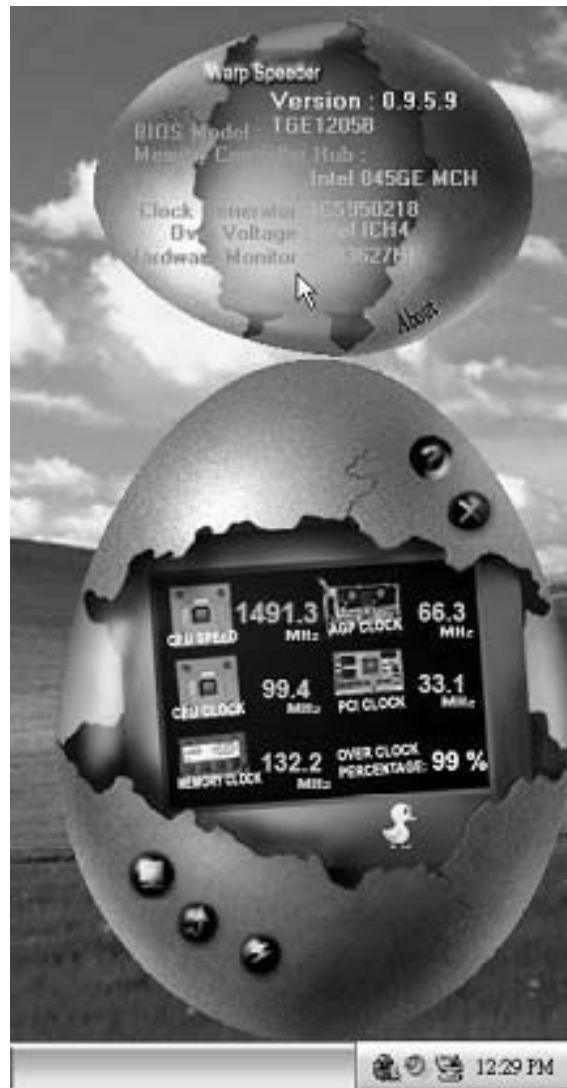

NF4 Ultra-A9

Note:

Because the overlock, overvoltage, and hardware monitor features are controlled by several separate chipset, [WarpSpeeder™] divide these features to separate panels. If one chipset is not on board, the correlative button in Main panel will be disabled, but will not interfere other panels' functions. This property can make [WarpSpeeder™] utility more robust.

08/15, 2005

NF4 Ultra-A9 BIOS Setup

BIOS Setup	1
1 Main Menu	3
2 Standard CMOS Features.....	6
3 Advanced BIOS Features	9
4 Advanced Chipset Features.....	12
5 Integrated Peripherals	15
6 Power Management Setup.....	21
7 PnP/PCI Configurations	24
8 PC Health Status	26
9 Frequency/Voltage Control.....	28

BIOS Setup

Introduction

This manual discussed Award™ Setup program built into the ROM BIOS. The Setup program allows users to modify the basic system configuration. This special information is then stored in battery-backed RAM so that it retains the Setup information when the power is turned off.

The Award BIOS™ installed in your computer system's ROM (Read Only Memory) is a custom version of an industry standard BIOS. This means that it supports Intel Pentium® 4 processor input/output system. The BIOS provides critical low-level support for standard devices such as disk drives and serial and parallel ports.

Adding important has customized the Award BIOS™, but nonstandard, features such as virus and password protection as well as special support for detailed fine-tuning of the chipset controlling the entire system.

The rest of this manual is intended to guide you through the process of configuring your system using Setup.

Plug and Play Support

These AWARD BIOS supports the Plug and Play Version 1.0A specification. ESCD (Extended System Configuration Data) write is supported.

EPA Green PC Support

This AWARD BIOS supports Version 1.03 of the EPA Green PC specification.

APM Support

These AWARD BIOS supports Version 1.1&1.2 of the Advanced Power Management (APM) specification. Power management features are implemented via the System Management Interrupt (SMI). Sleep and Suspend power management modes are supported. Power to the hard disk drives and video monitors can be managed by this AWARD BIOS.

ACPI Support

Award ACPI BIOS support Version 1.0 of Advanced Configuration and Power interface specification (ACPI). It provides ASL code for power management and device configuration capabilities as defined in the ACPI specification, developed by Microsoft, Intel and Toshiba.

NF4 Ultra-A9

PCI Bus Support

This AWARD BIOS also supports Version 2.1 of the Intel PCI (Peripheral Component Interconnect) local bus specification.

DRAM Support

DDR SDRAM (Double Data Rate Synchronous DRAM) are supported.

Supported CPUs

This AWARD BIOS supports the AMD CPU.

Using Setup

In general, you use the arrow keys to highlight items, press <Enter> to select, use the <PgUp> and <PgDn> keys to change entries, press <F1> for help and press <Esc> to quit. The following table provides more detail about how to navigate in the Setup program by using the keyboard.

Keystroke	Function
Up arrow	Move to previous item
Down arrow	Move to next item
Left arrow	Move to the item on the left (menu bar)
Right arrow	Move to the item on the right (menu bar)
Move Enter	Move to the item you desired
PgUp key	Increase the numeric value or make changes
PgDn key	Decrease the numeric value or make changes
+ Key	Increase the numeric value or make changes
- Key	Decrease the numeric value or make changes
Esc key	Main Menu – Quit and not save changes into CMOS Status Page Setup Menu and Option Page Setup Menu – Exit Current page and return to Main Menu
F1 key	General help on Setup navigation keys
F5 key	Load previous values from CMOS
F7 key	Load the optimized defaults
F10 key	Save all the CMOS changes and exit

1 Main Menu

Once you enter Award BIOS™ CMOS Setup Utility, the Main Menu will appear on the screen. The Main Menu allows you to select from several setup functions. Use the arrow keys to select among the items and press <Enter> to accept and enter the sub-menu.

!! WARNING !!

The information about BIOS defaults on manual (**Figure 1,2,3,4,5,6,7,8,9**) is just for reference, please refer to the BIOS installed on board, for update information.

■ **Figure 1. Main Menu**

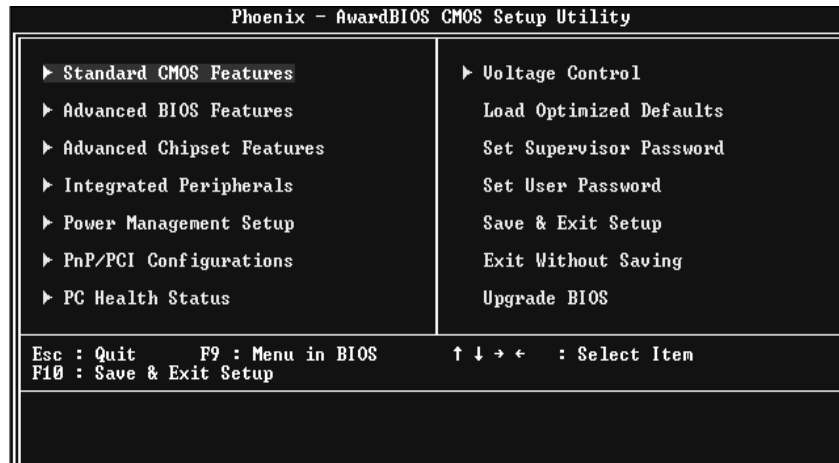

Standard CMOS Features

This submenu contains industry standard configurable options.

Advanced BIOS Features

This submenu allows you to configure enhanced features of the BIOS.

Advanced Chipset Features

This submenu allows you to configure special chipset features.

Integrated Peripherals

This submenu allows you to configure certain IDE hard drive options and Programmed Input/ Output features.

NF4 Ultra-A9

Power Management Setup

This submenu allows you to configure the power management features.

PnP/PCI Configurations

This submenu allows you to configure certain “Plug and Play” and PCI options.

PC Health Status

This submenu allows you to monitor the hardware of your system.

Frequency/ Voltage Control

This submenu allows you to change CPU Vcore Voltage and CPU/PCI clock. **(However, this function is strongly recommended not to use. Not properly change the voltage and clock may cause the CPU or M/B damage!)**

Load Optimized Defaults

This selection allows you to reload the BIOS when the system is having problems particularly with the boot sequence. These configurations are factory settings optimized for this system. A confirmation message will be displayed before defaults are set.

```
Load Optimized Defaults (Y/N)? N
```

Set Supervisor Password

Setting the supervisor password will prohibit everyone except the supervisor from making changes using the CMOS Setup Utility. You will be prompted with to enter a password.

```
Enter Password:
```

NF4 Ultra-A9

Set User Password

If the Supervisor Password is not set, then the User Password will function in the same way as the Supervisor Password. If the Supervisor Password is set and the User Password is set, the "User" will only be able to view configurations but will not be able to change them.

```
Enter Password:
```

Save & Exit Setup

Save all configuration changes to CMOS(memory) and exit setup. Confirmation message will be displayed before proceeding

```
SAVE to CMOS and EXIT (Y/N)? Y
```

Exit Without Saving

Abandon all changes made during the current session and exit setup. Confirmation message will be displayed before proceeding

```
Quit Without Saving (Y/N)? N
```

Upgrade BIOS

This submenu allows you to upgrade bios.

```
BIOS UPDATE UTILITY (Y/N)? N
```

2 Standard CMOS Features

The items in Standard CMOS Setup Menu are divided into 10 categories. Each category includes no, one or more than one setup items. Use the arrow keys to highlight the item and then use the <PgUp> or <PgDn> keys to select the value you want in each item.

■ Figure 2. Standard CMOS Setup

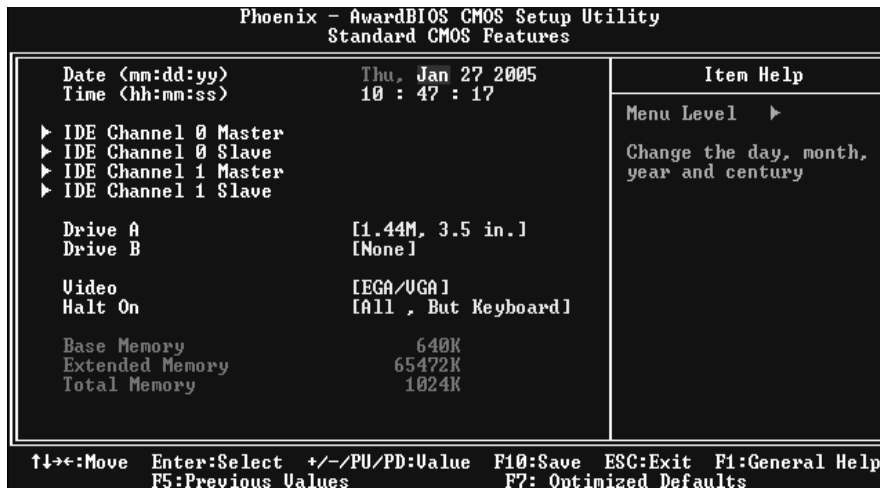

NF4 Ultra-A9

Main Menu Selections

This table shows the selections that you can make on the Main Menu.

Item	Options	Description
Date	mm : dd : yy	Set the system date. Note that the 'Day' automatically changes when you set the date.
Time	hh : mm : ss	Set the system internal clock.
IDE Primary Master	Options are in its sub menu.	Press <Enter> to enter the sub menu of detailed options
IDE Primary Slave	Options are in its sub menu.	Press <Enter> to enter the sub menu of detailed options.
IDE Secondary Master	Options are in its sub menu.	Press <Enter> to enter the sub menu of detailed options.
IDE Secondary Slave	Options are in its sub menu.	Press <Enter> to enter the sub menu of detailed options.
Drive A Drive B	360K, 5.25 in 1.2M, 5.25 in 720K, 3.5 in 1.44M, 3.5 in 2.88M, 3.5 in None	Select the type of floppy disk drive installed in your system.
Video	EGA/VGA CGA 40 CGA 80 MONO	Select the default video device.

NF4 Ultra-A9

Item	Options	Description
Halt On	All Errors No Errors All, but Keyboard All, but Diskette All, but Disk/ Key	Select the situation in which you want the BIOS to stop the POST process and notify you.
Base Memory	N/A	Displays the amount of conventional memory detected during boot up.
Extended Memory	N/A	Displays the amount of extended memory detected during boot up.
Total Memory	N/A	Displays the total memory available in the system.

3 Advanced BIOS Features

■ Figure 3. Advanced BIOS Setup

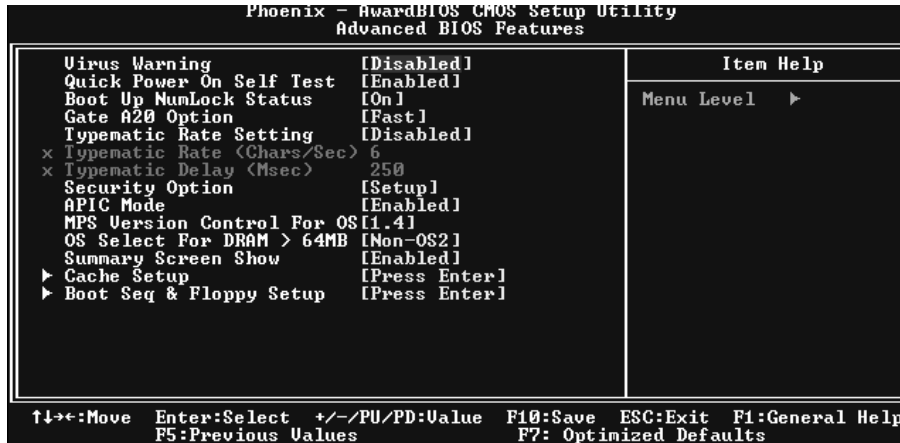

Virus Warning

This option allows you to choose the Virus Warning feature that is used to protect the IDE Hard Disk boot sector. If this function is enabled and an attempt is made to write to the boot sector, BIOS will display a warning message on the screen and sound an alarm beep.

- Disabled** (default) Virus protection is disabled.
- Enabled Virus protection is activated.

Quick Power On Self Test

Enabling this option will cause an abridged version of the Power On Self-Test (POST) to execute after you power up the computer.

- Enabled** (default) Enable quick POST.
- Disabled Normal POST.

Boot Up NumLock Status

Selects the NumLock. State after power on.

- On** (default) Numpad is number keys.
- Off Numpad is arrow keys.

Gate A20 Option

Select if chipset or keyboard controller should control Gate A20.

- Normal A pin in the keyboard controller controls Gate A20.
- Fast** (default) Lets chipset control Gate A20.

NF4 Ultra-A9

Typematic Rate Setting

When a key is held down, the keystroke will repeat at a rate determined by the keyboard controller. When enabled, the typematic rate and typematic delay can be configured.

Disabled (default)

Enabled

Typematic Rate (Chars/Sec)

Sets the rate at which a keystroke is repeated when you hold the key down.

The Choices: 6 (default), 8,10,12,15,20,24,30.

Typematic Delay (Msec)

Sets the delay time after the key is held down before it begins to repeat the keystroke.

The Choices: 250 (default), 500,750,1000.

Security Option

This option will enable only individuals with passwords to bring the system online and/or to use the CMOS Setup Utility.

System

A password is required for the system to boot and is also required to access the Setup Utility.

Setup (default)

A password is required to access the Setup Utility only.

This will only apply if passwords are set from the Setup main menu.

APIC MODE

Selecting Enabled enables ACPI device mode reporting from the BIOS to the operating system.

The Choices: Enabled (default), Disabled.

MPS Version Control For OS

The BIOS supports version 1.1 and 1.4 of the Intel multiprocessor specification.

Select version supported by the operation system running on this computer.

The Choices: 1.4 (default), 1.1.

OS Select For DRAM > 64MB

A choice other than Non-OS2 is only used for OS2 systems with memory exceeding 64MB.

The Choices: Non-OS2 (default), OS2.

Summary Screen Show

This item allows you to enable/ disable display the Summary Screen Show.

The Choices: Disabled (default), Enabled.

NF4 Ultra-A9

Cache Setup

These BIOS attempt to load the operating system from the device in the sequence selected in these items.

CPU Internal Cache

Depending on the CPU/chipset in use, you may be able to increase memory access time with this option.

Enabled (default) Enable cache.
Disabled Disable cache.

External Cache

This option enables or disables "Level 2" secondary cache on the CPU, which

Boot Seq & Floppy Setup

Hard Disk Boot Priority

These BIOS attempt to load the operating system from the device in the sequence selected in these items.

The Choices: Pri. Master, Pri. Slave, Sec. Master, Sec. Slave, USBHDD0, USB HDD1, USB HDD2, and Bootable Add-in Cards.

First/ Second/ Third/ Boot Other Device

These BIOS attempt to load the operating system from the devices in the sequence selected in these items.

The Choices: Floppy, LS120, HDD-0, SCSI, CDROM, HDD-1, HDD-2, HDD-3, ZIP100, LAN, Disabled.

Swap Floppy Drive

For systems with two floppy drives, this option allows you to swap logical drive assignments.

The Choices: Disabled (default), Enabled.

Boot Up Floppy Seek

Enabling this option will test the floppy drives to determine if they have 40 or 80 tracks. Disabling this option reduces the time it takes to boot-up.

The Choices: Enabled (default), Disabled.

4 Advanced Chipset Features

This submenu allows you to configure the specific features of the chipset installed on your system. This chipset manage bus speeds and access to system memory resources, such as DRAM. It also coordinates communications with the PCI bus. The default settings that came with your system have been optimized and therefore should not be changed unless you are suspicious that the settings have been changed incorrectly.

■ **Figure 4. Advanced Chipset Setup**

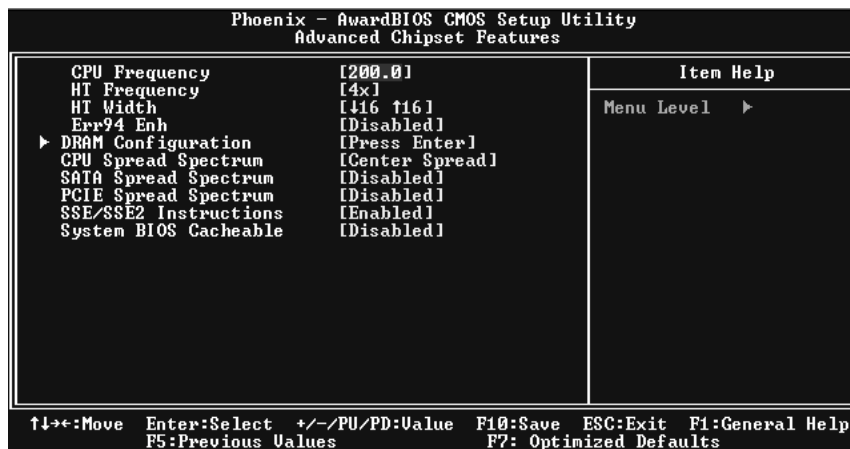

CPU Frequency

This item allows you to select the CPU Frequency.
The Choices: 200 (default).

HT Frequency

This item allows you to select the HT Frequency.
The Choices: 4x (default).

HT Width

This item allows you to control the utilized width of the outgoing side of the HyperTransport link.

Err94 Enh

This item allows you to enable/disable the “sequential Prefetch Feature” of K8 CPU.
 The choices: **Disabled** (default), enable.

NF4 Ultra-A9

DRAM Configuration

Phoenix - AwardBIOS CMOS Setup Utility	
DRAM Configuration	
Timing Mode	[Auto]
x Memclock index value (Mhz)	200Mhz
x CAS# latency (Tcl)	2.5
x Min RAS# active time (Tras)	8T
x RAS# to CAS# delay (Trcd)	4T
x Row precharge Time (Trp)	2T

Item Help
Menu Level >>

↑↓←→:Move Enter:Select +/-/PU/PD:Value F10:Save ESC:Exit F1:General Help
F5:Previous Values F7: Optimized Defaults

CAS# Latency

This field specify the cas# latency, i.e. cas# to read data valid.

The Choices: CL=2.5 (Default), CL=3.0, CL=2.0

Min RAS# active time (tRAS)

This field specifies the minimum RAS# active time. Typically -45-60 Nsec.

The Choices: 6 BUS CLOCKS (Default), 13 BUS CLOCKS, 14 BUS CLOCKS, 15 BUS CLOCKS.

RAS# to CAS# Delay (tRCD)

This field specifies the RAS# to CAS# Delay to read/ write command to the same bank. Typically -20 Nsec.

The Choices: 3 BUS CLOCKS (Default), 2 BUS CLOCKS, 4 BUS CLOCKS, 5 BUS CLOCKS, 6 BUS CLOCKS, 7 BUS CLOCKS

Row precharge Time (tRP)

This field specifies the Row precharge Time. Precharge to Active or Auto-Refresh of the same bank. Typically 20-24 Nsec.

The Choices: 3 BUS CLOCKS (Default), 2 BUS CLOCKS, 4 BUS CLOCKS, 5 BUS CLOCKS, 6 BUS CLOCKS.

CPU Spread Spectrum

The choices: **Center Spread** (default).

SATA Spread Spectrum

This item allows you to disable \ enable the SATA spread spectrum function.

The choices: **Disabled** (default), enable.

NF4 Ultra-A9

PCIE Spread Spectrum

This item allows you to disable \ enable the SATA spread spectrum function.

The choices: **Disabled** (default), enable.

SSE/SSE2 Instructions

The choices: **Enabled** (default), Disabled.

System BIOS Cacheable

Selecting the “Disabled ” option allows caching of the system BIOS ROM at F0000h-FFFFh which can improve system performance. However, any programs writing to this area of memory will cause conflicts and result in system errors.

The Choices: **Disabled** (default), Enabled.

5 Integrated Peripherals

■ Figure 5. Integrated Peripherals

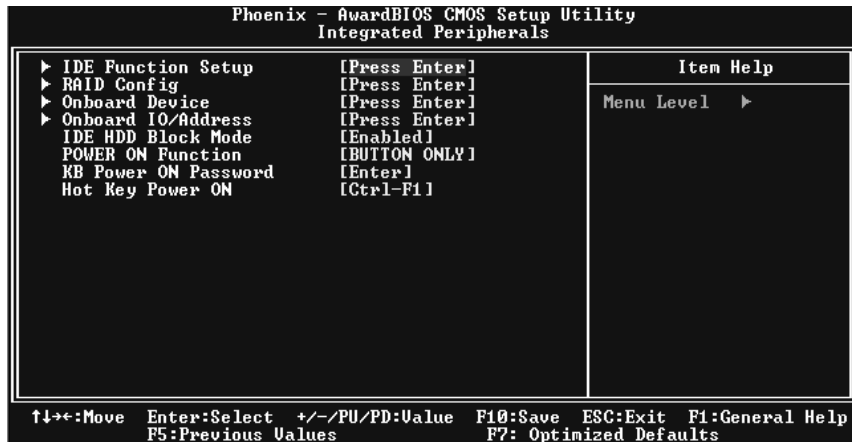

IDE Function Setup

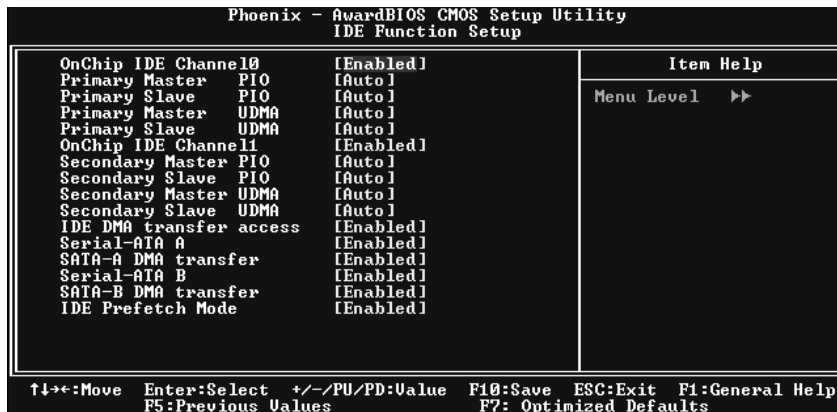

If you highlight the literal “Press Enter” next to the “IDE Function Setup” label and then press the enter key, it will take you a submenu with the following options:

OnChip IDE Channel 0/1

The motherboard chipset contains a PCI IDE interface with support for two IDE channels. Select “Enabled” to activate the first and/or second IDE interface. Select “Disabled” to deactivate an interface if you are going to install a primary and/or secondary add-in IDE interface.

The Choices: Enabled (default), Disabled.

NF4 Ultra-A9

Primary / Secondary / Master / Slave PIO

The IDE PIO (Programmed Input / Output) fields let you set a PIO mode (0-4) for each of the IDE devices that the onboard IDE interface supports. Modes 0 to 4 will increase performance progressively. In Auto mode, the system automatically determines the best mode for each device.

The Choices: Auto (default), Mode0, Mode1, Mode2, Mode3, Mode4.

Primary / Secondary / Master / Slave UDMA

Ultra DMA/100 functionality can be implemented if it is supported by the IDE hard drives in your system. As well, your operating environment requires a DMA driver (Windows 95 OSR2 or a third party IDE bus master driver). If your hard drive and your system software both support Ultra DMA/100, select Auto to enable BIOS support.

The Choices: Auto (default), Disabled.

IDE DMA Transfer Access

The Choices: Enabled (default), Disabled.

Serial-ATA A

Enables support for Serial-ATA1.

The Choices: Enabled (default), Disabled

SATA DMA transfer

The Choices: Enabled (default), Disabled.

Serial-ATA B

Enables support for Serial-ATA2.

The Choices: Enabled (default), Disabled

SATA2 DMA transfer

The Choices: Enabled (default), Disabled.

IDE Prefetch Mode

The Choices: Enabled (default), Disabled.

NF4 Ultra-A9

RAID Configuration

```
Phoenix - AwardBIOS CMOS Setup Utility
RAID Config

RAID Enable [Disabled]
x IDE Primary Master RAID Disabled
x IDE Primary Slave RAID Disabled
x IDE Secndry Master RAID Disabled
x IDE Secndry Slave RAID Disabled
x SATA A Primary RAID Disabled
x SATA A Secondary RAID Disabled
x SATA B Primary RAID Disabled
x SATA B Secondary RAID Disabled

Item Help
Menu Level  >>

↑↓+↔:Move  Enter:Select  +/-/PU/PD:Uvalue  F10:Save  ESC:Exit  F1:General Help
F5:Previous Values  F7: Optimized Defaults
```

RAID Enable

The choices: **Disabled** (default), enable.

ONBOARD DEVICE

```
Phoenix - AwardBIOS CMOS Setup Utility
Onboard Device

OnChip USB [V1.1+V2.0]
USB Keyboard Support [Disabled]
USB Mouse Support [Disabled]
AC97 Audio [Auto]
MAC Lan [Auto]
Onboard Lan Boot ROM [Disabled]
MAC Media Interface [Pin Strap]
Onboard 1394 [Enabled]

Item Help
Menu Level  >>

↑↓+↔:Move  Enter:Select  +/-/PU/PD:Uvalue  F10:Save  ESC:Exit  F1:General Help
```

OnChip USB

This option should be enabled if your system has a USB installed on the system board. You will need to disable this feature if you add a higher performance controller.

The Choices: **V1. 1+V2. 0** (default), Disabled, V1.1

NF4 Ultra-A9

USB keyboard Support

Enables support for USB attached keyboard.

The Choices: Disabled (default), Enabled

USB Mouse Support

Enables support for USB attached mouse.

The Choices: Disabled (default), Enabled

AC97 Audio

This option allows you to control the onboard AC97 audio.

The Choices: Auto (default), Disabled.

MAC LAN (nVIDIA)

This option allows you to change the state of the onboard MAC LAN.

The Choices: Auto (Default), Disabled.

Onboard LAN Boot ROM

This item allows you to enable or disable Onboard LAN Boot ROM.

The Choices: Disabled (default), Enabled.

MAC Media Interface

The Choices: Pin Strap (default).

Onboard 1394

This item allows you to enable or disable the Onboard 1394 Controller.

The Choices: Enabled (default), Disabled.

NF4 Ultra-A9

ONBOARD IO/Address

Phoenix - AwardBIOS CMOS Setup Utility		
Onboard IO/Address		
Onboard FDC Controller	[Enabled]	Item Help
Onboard Serial Port 1	[3F8/IRQ4]	Menu Level ▶▶
Onboard IR Function	[Disabled]	
UART Mode Select	[IrDA]	
UR2 Duplex Mode	[Half]	
Onboard Parallel Port	[378/IRQ7]	
Parallel Port Mode	[SPP]	
ECP Mode Use DMA	[3]	

↑↓←→:Move Enter:Select +/-/PU/PD:Value F10:Save ESC:Exit F1:General Help
F5:Previous Values F7: Optimized Defaults

Onboard FDC Controller

Select Enabled if your system has a floppy disk controller (FDC) installed on the system board and you wish to use it. If install and FDC or the system has no floppy drive, select Disabled in this field.

The Choices: Enabled (**default**), Disabled.

Onboard Serial Port 1

Select an address and corresponding interrupt for the first and second serial ports.

The Choices: Disabled, **3F8/IRQ4** (default), 2F8/IRQ3, 3E8/IRQ4, 2E8/IRQ3, Auto.

Onboard IR Function

The Choices: Disabled (default), **Enabled**.

UART Mode Select

This item allows you to determine which Infra Red (IR) function of onboard I/O chip.

The Choices: Normal (default), AS KIR, IrDA.

UR2 Duplex Mode

Select the value required by the IR device connected to the IR port.

Full-duplex mode permits simultaneous two-direction transmission.

Half-duplex mode permits transmission in one direction only at a time.

The Choices: Half (default), Full.

NF4 Ultra-A9

Onboard Parallel Port

This item allows you to determine access onboard parallel port controller with which I/O Address.

The Choices: 378/IRQ7 (default), 278/IRQ5, 3BC/IRQ7, Disabled.

Parallel Port Mode

The default value is SPP.

The Choices:

SPP(default) Using Parallel port as Standard Printer Port.

EPP Using Parallel Port as Enhanced Parallel Port.

ECP Using Parallel port as Extended Capabilities Port.

ECP+EPP Using Parallel port as ECP & EPP mode.

ECP Mode Use DMA

Select a DMA Channel for the port.

The Choices: 3 (default), 1.

IDE HDD Block Mode

Block mode is also called block transfer, multiple commands, or multiple sector read / write. If your IDE hard drive supports block mode (most new drives do), select Enabled for automatic detection of the optimal number of block mode (most new drives do), select Enabled for automatic detection of the optimal number of block read / write per sector where the drive can support.

The Choices: Enabled (default), Disabled.

Power on Function

This option allows you to choose the different function to power on the computer.

The Choices: Hot Key (default), Password, Mouse Move, Mouse Click, Any Key, Button Only, Keyboard 98.

KB Power ON Password

Input password and press Enter to set the Keyboard power on password.

Hot Key Power on

This option allows you to choose a hot key to power on.

The Choices: Ctrl-F1 (default), Ctrl-F2, Ctrl-F3, Ctrl-F4, Ctrl-F5, Ctrl-F6, Ctrl-F7, Ctrl-F8

6 Power Management Setup

The Power Management Setup Menu allows you to configure your system to utilize energy conservation and power up/power down features.

■ **Figure 6. Power Management Setup**

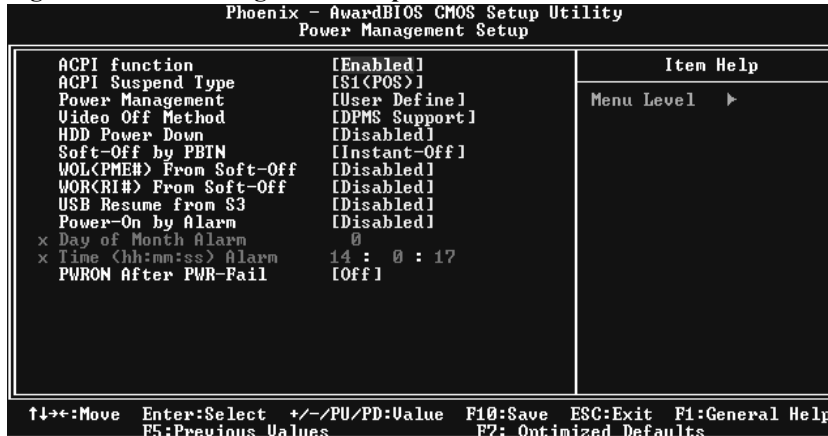

ACPI function

This item displays the status of the Advanced Configuration and Power Management (ACPI).

The Choices: Enabled (default), Disabled.

ACPI Suspend Type

The item allows you to select the suspend type under the ACPI operating system.

The Choices: S1 (POS) (default) Power on Suspend
S3 (STR) Suspend to RAM
S1+S3 POS+STR

Power Management

This category allows you to select the type (or degree) of power saving and is directly related to the following modes:

- 1.HDD Power Down.
- 2.Suspend Mode.

There are four options of Power Management, three of which have fixed mode settings
Min. Power Saving

Minimum power management.
Suspend Mode = 1 hr.

NF4 Ultra-A9

HDD Power Down = 15 min

Max. Power Saving

Maximum power management only available for sl CPU's.

Suspend Mode = 1 min.

HDD Power Down = 1 min.

User Define (default)

Allows you to set each mode individually.

When not disabled, each of the ranges are from 1 min. to 1 hr. except for HDD Power Down which ranges from 1 min. to 15 min. and disable.

Video Off Method

This option determines the manner in which the monitor is goes blank.

V/H SYNC+Blank (default)

This selection will cause the system to turn off the vertical and horizontal synchronization ports and write blanks to the video buffer.

Blank Screen

This option only writes blanks to the video buffer.

DPMS

Initial display power management signaling

The Choices: Stop Grant, PwrOn Suspend.

HDD Power Down

When enabled, the hard disk drive will power down and after a set time of system inactivity. All other devices remain active.

The Choices: Disabled (default), 1 Min, 2 Min, 3 Min, 4 Min, 5 Min, 6 Min, 7 Min, 8 Min, 9 Min, 10 Min, 11 Min, 12 Min, 13 Min, 14 Min, 15Min.

Soft-Off by PWR-BTTN

Pressing the power button for more than 4 seconds forces the system to enter the Soft-Off state when the system has "hung."

The Choices: Delay 4 Sec, Instant-Off (default).

WOL (PME#) From Soft-Off

The Choices: Disabled (default), Enabled.

WOR (RI#) From Soft-Off

The Choices: Disabled (default), Enabled.

NF4 Ultra-A9

USB Resume from S3

The Choices: Disabled (default), Enabled.

Power-On by Alarm

When you select Enabled, an alarm returns the system to Full ON state.

The Choices: Disabled (default), Enabled.

POWER After PWR-Fail

This setting specifies whether your system will reboot after a power fail or interrupts occurs.

Off Leaves the computer in the power off state.

On Reboots the computer.

Former-Sts Restores the system to the status before power failure or interrupt occurs.

The Choices: Off (default), On, Former-Sts.

7 PnP/PCI Configurations

This section describes configuring the PCI bus system. PCI, or Personal Computer Interconnect, is a system which allows I/O devices to operate at speeds nearing the speed of the CPU itself uses when communicating with its own special components. This section covers some very technical items and it is strongly recommended that only experienced users should make any changes to the default settings.

■ Figure 7. PnP/PCI Configurations

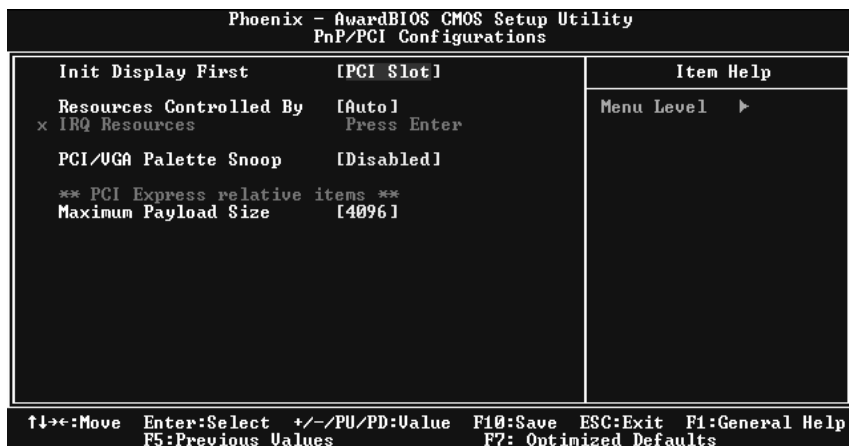

Init Display First

With systems that have multiple video cards, this option determines whether the primary display uses a PCI Slot or an AGP Slot.

The Choices: PCI Slot (default), AGP.

Resources Controlled By

By Choosing “Auto(ESCD)” (default), the system BIOS will detect the system resources and automatically assign the relative IRQ and DMA channel for each peripheral. By Choosing “Manual”, the user will need to assign IRQ & DMA for add-on cards. Be sure that there are no IRQ/DMA and I/O port conflicts.

IRQ Resources

This submenu will allow you to assign each system interrupt a type, depending on the type of device using the interrupt. When you press the “Press Enter” tag, you will be directed to a submenu that will allow you to configure the system interrupts. This is only configurable when “Resources Controlled By” is set to “Manual”.

NF4 Ultra-A9

IRQ-3	assigned to	PCI Device
IRQ-4	assigned to	PCI Device
IRQ-5	assigned to	PCI Device
IRQ-7	assigned to	PCI Device
IRQ-9	assigned to	PCI Device
IRQ-10	assigned to	PCI Device
IRQ-11	assigned to	PCI Device
IRQ-12	assigned to	PCI Device
IRQ-14	assigned to	PCI Device
IRQ-15	assigned to	PCI Device

PCI / VGA Palette Snoop

Choose Disabled or Enabled. Some graphic controllers which are not VGA compatible take the output from a VGA controller and map it to their display as a way to provide boot information and VGA compatibility.

However, the color information coming from the VGA controller is drawn from the palette table inside the VGA controller to generate the proper colors, and the graphic controller needs to know what is in the palette of the VGA controller. To do this, the non-VGA graphic controller watches for the Write access to the VGA palette and registers the snoop data. In PCI based systems, where the VGA controller is on the PCI bus and a non-VGA graphic controller is on an ISA bus, the Write Access to the palette will not show up on the ISA bus if the PCI VGA controller responds to the Write.

In this case, the PCI VGA controller should not respond to the Write, it should only snoop the data and permit the access to be forwarded to the ISA bus. The non-VGA ISA graphic controller can then snoop the data on the ISA bus. Unless you have the above situation, you should disable this option.

Disabled (default)	Disables the function.
Enabled	Enables the function.

Maximum Payload Size

Set the maximum payload size for Transaction packets (TLP).

The Choice: 4096 (default.)

8 PC Health Status

■ Figure 8. PC Health Status



Chassis Open Warning

This item allows you to enable or disable Chassis Open Warning beep.

The Choices: Disabled (Default), Enabled.

Shutdown Temperature

This item allows you to set up the CPU shutdown Temperature. This item only effective under Windows 98 ACPI mode.

The Choices: Disabled (default), 60°C/140F, 65°C/149F, 70°C/158F, 75°C/167F.

Show H/W Monitor in POST

If your computer contains a monitoring system, it will show PC health status during POST stage. The item offers several delay time for you to choose.

The Choices: Enabled (default), Disabled.

CPU Vcore/+1.5V+3.3V/+5.0V/+12.0V/+5V/5VSB/ Voltage Battery

Detect the system's voltage status automatically.

CPU Temperature

This field displays the current temperature of the CPU.

NF4 Ultra-A9

Current CPU FAN Speed

This field displays the current speed of CPU fan.

Current SYS FAN Speed

This field displays the current speed SYSTEM fan.

9 Frequency/Voltage Control

■ Figure 8. PC Health Status

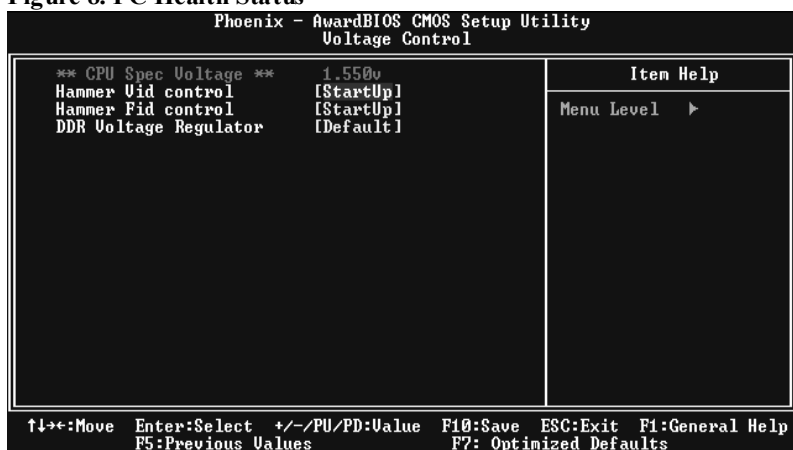

Hammer Vid Control

This item allows you to set different CPU frequency.

The Choices: StartUp (default), and other choices from 800Mhz to 5000Mhz.

Hammer Fid Control

This item allows you to set different CPU voltage.

The Choices: StartUp (default), and other choices from 1.625V to 0.8V.

DDR Voltage Regulator

This item allows you to set different DDR voltage.

The Choices: 2.7V, 2.8V, 2.9V.