

n250a / n250a-FR / n250a-L

- Realtek Gigabit LAN chip (for n250a-FR and n250a-L)
- Realtek 10/100Mbps LAN chip (for n250a)
- CD-IN Connector
- AUX-IN Connector
- Onboard AC'97 CODEC
- Front Audio Connector
- Self-Powered PCI Slot that supports high power-consuming PCI cards (only for n250a-FR)
- Game Port Connector
- S/PDIF Connector
- 32-bit PCI Expansion Slots x5
- Case Open Connector
- SYSFAN2 Connector
- IrDA Connector
- IEEE1394 Connectors x 2 (only for n250a-FR)
- USB 2.0 Connector
- Silicon Image Serial ATA Controller (only for n250a-FR)
- JP25 BIOS Protection Jumper (only for n250a-FR)
- JP24 BIOS Rescue Jumper (only for n250a-FR)
- Serial ATA Ports
- Supports 150 MB/s Transfer Rate
- Front Panel Connector
- JP2 Speaker output Jumper (only for n250a-FR)
- JP15/JP16 Dr. Voice II Language Selection Jumper (only for n250a-FR)
- Die-hard BIOS x2 (only for n250a-FR)
- JP14 CMOS Data Clear Jumper

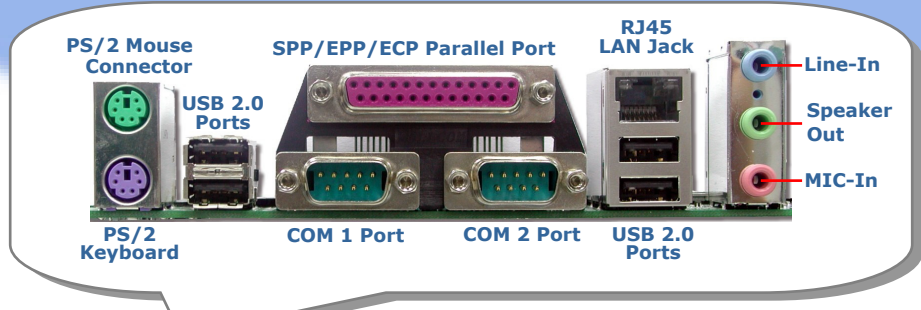

- JP28 PS2 KB/Mouse Wakeup Jumper
- Resetable Fuse
- AGP Protection LED
- 4-pin 12V ATX Power Connector
- 3300 μ F Low ESR Capacitor
- CPUFAN Connector
- SYSFAN1 Connector
- AGP 8X Expansion Slot that supports 8X AGP card(2.1GB/s)
- 184-pin DIMMsx3 support DDR400/333/266 Max. To 3GB
- 754-pin CPU socket with Voltage and Frequency Auto-detection that supports AMD™ Athlon™ 64 CPU
- NVIDIA nForce3 250 Chipsets that support DDR400/333/266 and AGP 8X
- IDE Connectors x 2 (ATA66/100/133 supported)
- ATX Power Connector
- FDD Connector

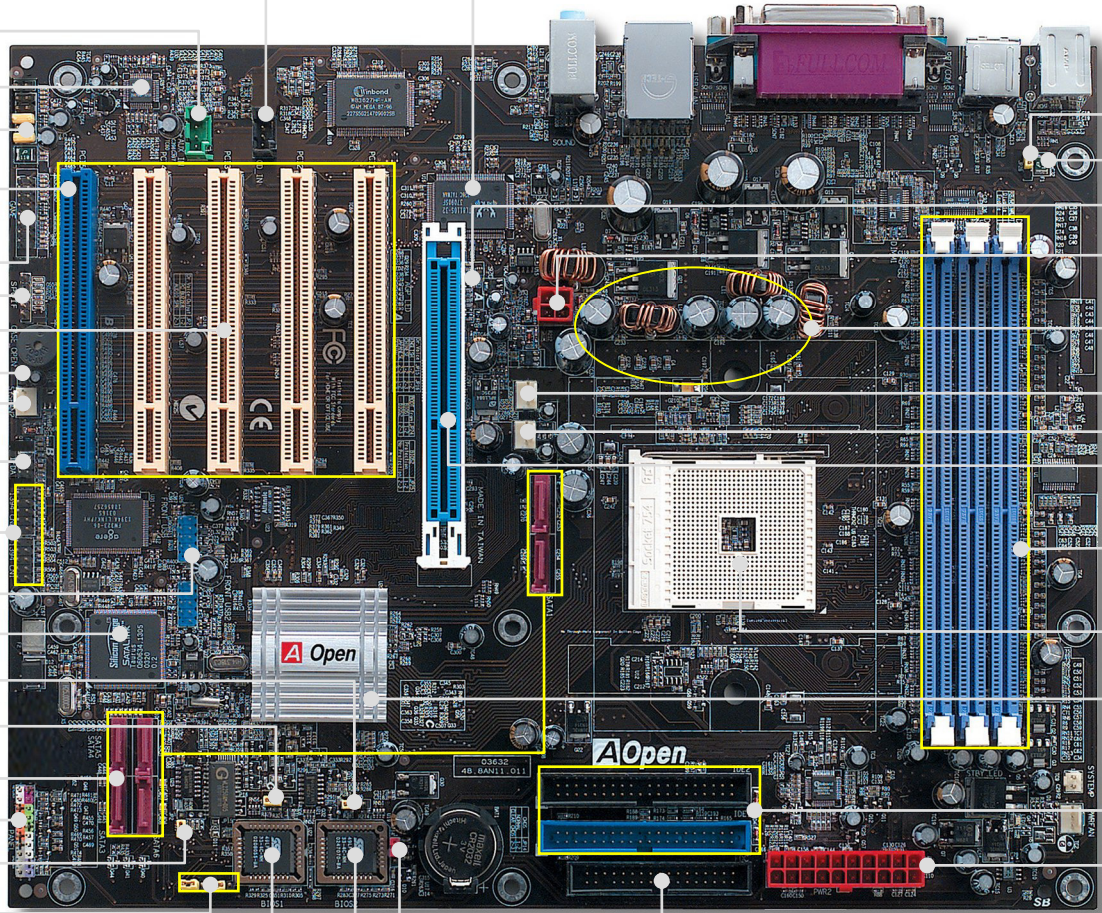

Before You Start

Everything you need to boot this motherboard is included in this Easy Installation Guide. For more information, a complete **Online User's Manual** can be found in the **Bonus Pack CD**. Thanks for the help of saving our earth.

Accessory Checklist

- Easy Installation Guide x 1
- Enhanced Full Pictured Manual x 1
- 40-Wire IDE Cable x 1 (only for n250a-FR)
- 80-Wire ATA 133 Cable x 1
- Floppy Drive Cable x 1
- Serial ATA Cable x 1
- Serial ATA Power Cable x 1
- IEEE 1394 Cable x 1 (only for n250a-FR)
- USB 2.0+Game Port Cable x 1 (only for n250a-FR)
- S/PDIF Cable x 1 (only for n250a-FR)
- Bonus Pack CD x 1
- Norton Anti-Virus CD x 1
- Silicon Image Serial ATA Driver Diskette x 1 (only for n250a-FR)
- I/O Shield x 1

Installing By Yourself



PART NO: 49.8AN02.E01

DOC. NO: N250AFR-EG-E0404A



1. Installing CPU

This motherboard supports AMD® Athlon 64 Socket 754 CPU. Be careful of CPU orientation when you plug it into CPU socket.
CPU socket lever

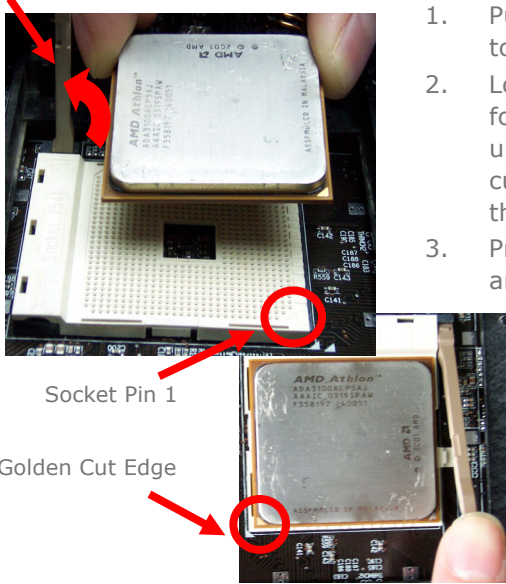

1. Pull up the CPU socket lever and up to 90-degree angle.
2. Locate Pin 1 in the socket and look for a (golden) cut edge on the CPU upper interface. Match Pin 1 and cut edge. Then insert the CPU into the socket.
3. Press down the CPU socket lever and finish CPU installation.

Note: If you do not match the CPU socket Pin 1 and CPU cut edge well, you may damage the CPU.

2. Installing CPU & System Fans

Plug in the CPU fan cable to the 3-pin CPUFAN connector. If you have chassis fan, you can also plug it in SYSFAN1 or SYSFAN2 connector.

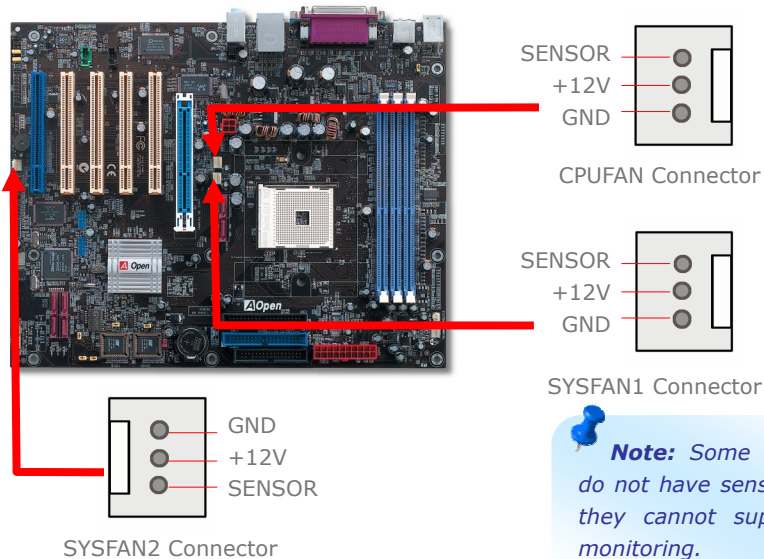

Note: Some CPU fans do not have sensor pin so they cannot support fan monitoring.

3. Installing Memory Modules

DIMM slots are designed in Navy Blue or Electronic Blue which are very easy to recognize. Insert the module straight down to the DIMM slot with both hands and press down firmly until the DIMM module is securely in place.

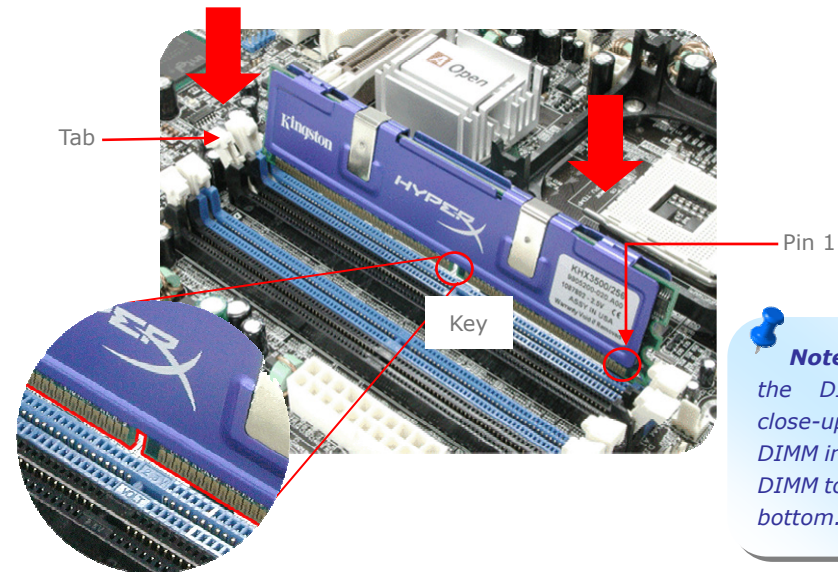

Note: The tabs of the DIMM slot will close-up to hold the DIMM in place when the DIMM touches the slot's bottom.

4. Connecting IDE and Floppy Cables

Connect 34-pin floppy cable and 40-pin, 80-wire IDE cable to floppy connector FDD and IDE connector. Be careful of the pin1 orientation. Wrong orientation may cause system damage.

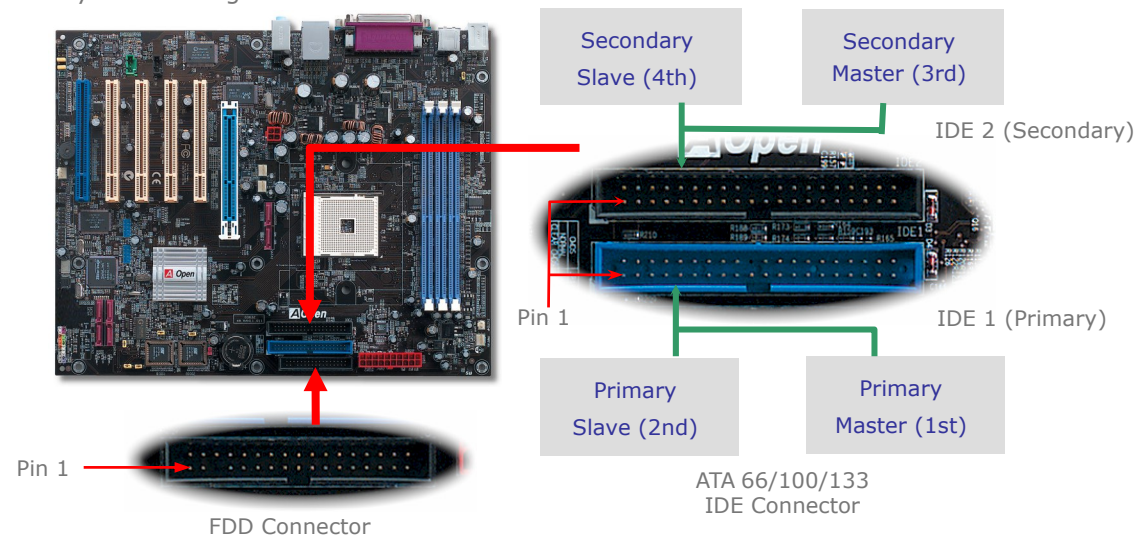

5. Connecting ATX Power Cables

This motherboard comes with a 20-pin and 4-pin ATX power connector as shown below. Make sure you plug in the right direction. We strongly recommend you to insert the 4-pin connector before connecting the 20-pin connector.

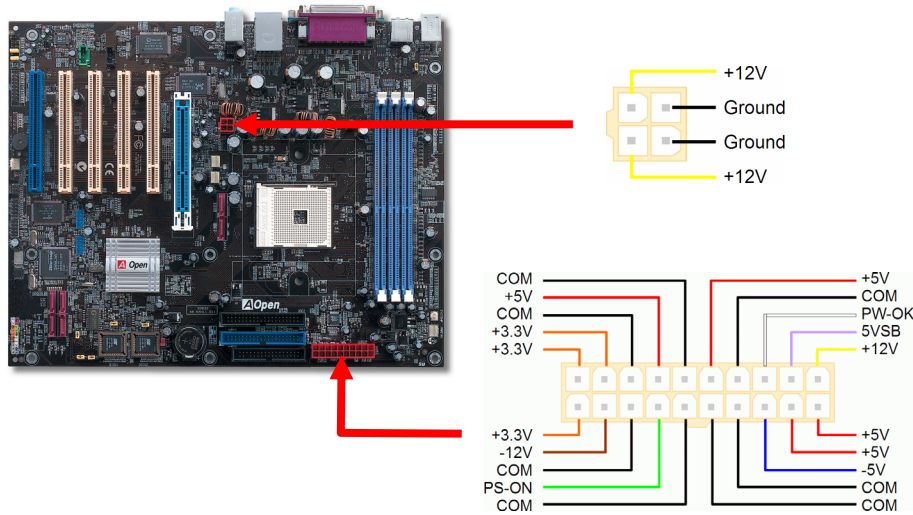

6. Connecting Front Panel Cable

Attach the power LED, speaker, and reset switch connectors to the corresponding pins. If you enable "Suspend Mode" item in BIOS Setup, the ACPI & Power LED will keep flashing while the system is in suspend mode.

Locate the power switch cable from your ATX housing. It is 2-pin female connector from the housing front panel. Plug this connector to the soft-power switch connector marked *SPWR*.

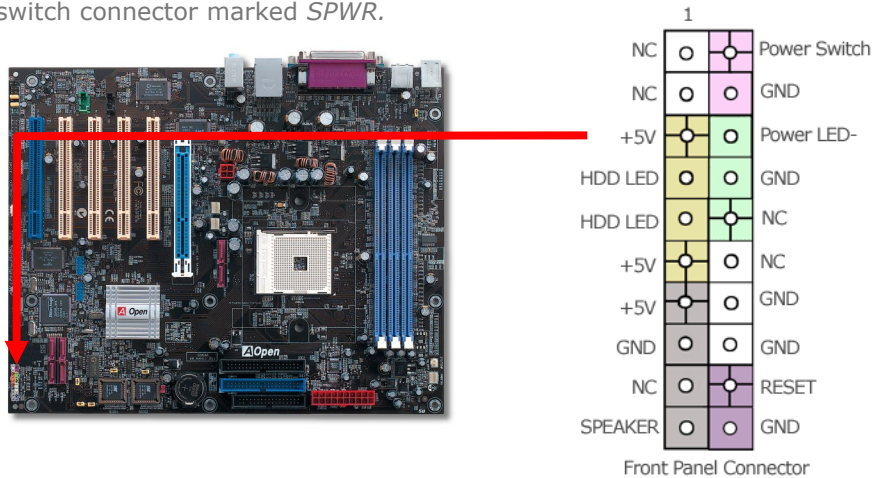

7. Power-on and Loading BIOS Setup

Del

After you finish the setting of jumpers and connect correct cables. Power on and enter the BIOS Setup, press during POST (Power On Self Test). Choose "Load Setup Defaults" for recommended optimal performance.

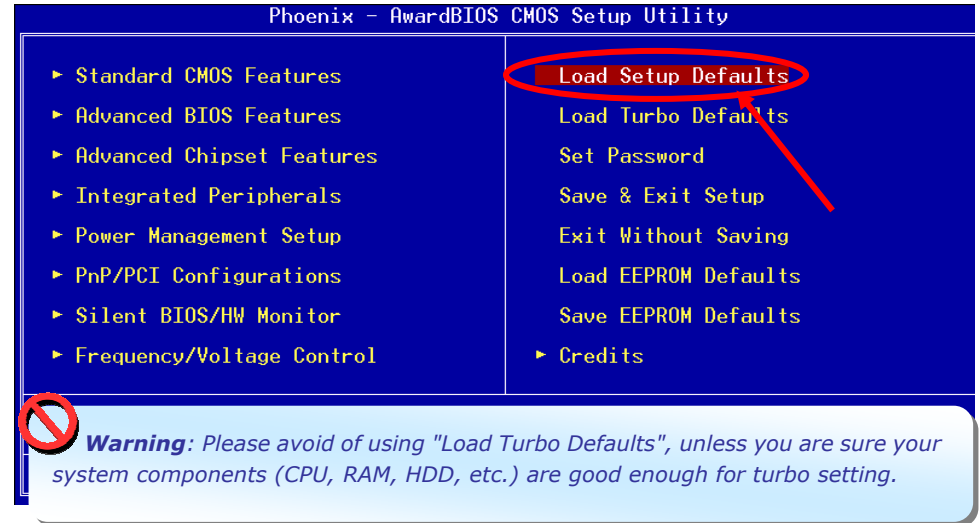

8. AOpen Bonus Pack CD

You can use the autorun menu of Bonus CD disc. Choose the utility or driver, select model name and complete installation.

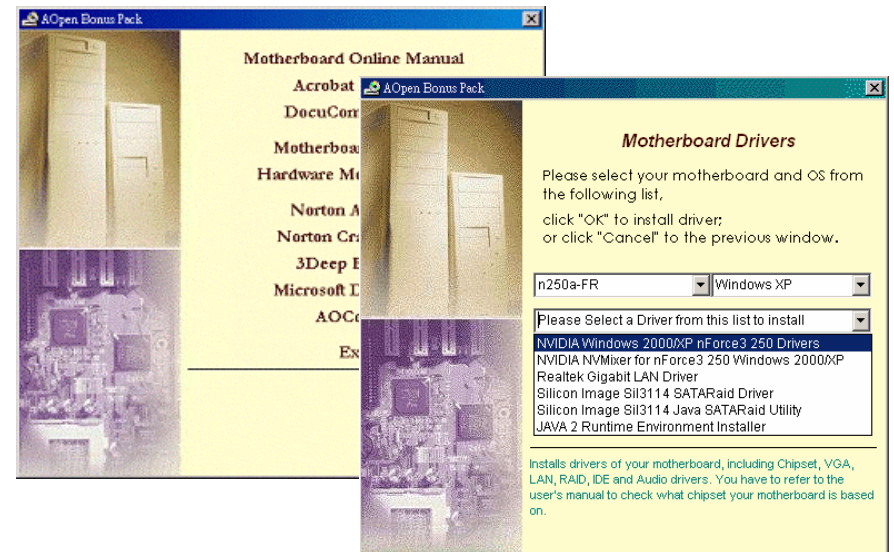

Setting CPU Voltage & Frequency

Setting CPU Core Voltage

This motherboard supports Voltage ID (VID) function to detect CPU voltage automatically during power-on. However, if users are willing to do overclocking, we also provide a range from 0.80V to 1.55V in the BIOS. Sometimes increasing the original core voltage a little bit will lead the CPU overclock more properly.

Setting CPU Frequency

This motherboard is CPU jumper-less design, you can set CPU frequency through 1MHz stepping CPU Overclocking in the BIOS. CPU Core Frequency = CPU FSB clock x CPU Ratio. However, all CPU now selling in the market belong to "Fixed Multiplier". That means users can not adjust the CPU Ratio but only change CPU FSB clock to achieve overclocking.

(Users do the overclocking at their own risk!!)

BIOS Setup > Frequency / Voltage Control > CPU Speed Setup

CPU Ratio	From 4x to 25x step 1x
CPU Clock (Adjustment manually)	FSB = 200 MHz-250 MHz by 1 MHz Stepping CPU Overclocking

CPU	CPU Core	CPU Clock	L2 Cache	Ratio
Athlon 64 2800+	1800MHz	200MHz	512KB	9x
Athlon 64 3000+	2000MHz	200MHz	512KB	10x
Athlon 64 3200+	2000MHz	200MHz	1024KB	10x
Athlon 64 3200+	2200MHz	200MHz	512KB	11x
Athlon 64 3400+	2200MHz	200MHz	1024KB	11x
Athlon 64 3400+	2400MHz	200MHz	512KB	12x
Athlon 64 3700+	2400MHz	200MHz	1024KB	12x

Note: With CPU speed changing rapidly, there might be faster CPU on the market by the time you received this installation guide. This table is kindly for your references only, please contact with your distributor for more information.

Warning: Supposed you have had adjusted CPU ratio on your current CPU, and you plan to replace a new CPU. Please use <Home> key or Clear CMOS to restore the default setting when changing a new CPU, because the system will still implement the previous CPU setting on the new one.

Warning: NVidia nForce3 250 chipset supports maximum 200MHz system clock and 66MHz AGP clock; higher clock setting may cause serious system damage.

Note: If your system hangs or fails to boot because of overclocking, simply use <Home> key to restore the default setting or you can wait the AOpen "Watch Dog ABS" reset the system in five seconds and system will auto-detect hardware again.

JP14 Clear CMOS

You can clear CMOS to restore system default setting. To clear the CMOS, follow the procedure below.

1. Turn off the system and unplug the AC power.
2. Remove ATX power cable from connector PWR2.
3. Locate JP14 and short pins 2-3 for a few seconds.
4. Return JP14 to its normal setting by shorting pin 1 & pin 2.
5. Connect ATX power cable back to connector PWR2.

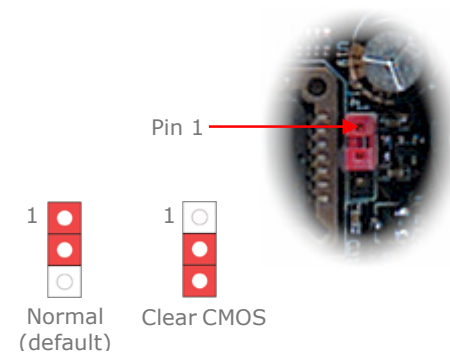
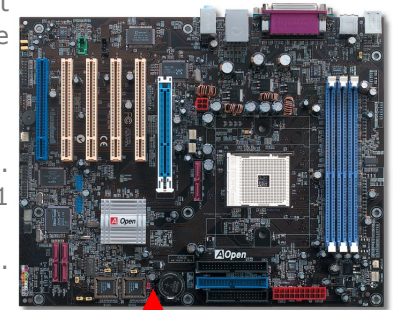

Tip: When should I Clear CMOS?

1. Boot fails because of overclocking...
2. Forget password...
3. Troubleshooting...

JP28 Keyboard/Mouse Wakeup Jumper

This motherboard provides keyboard / mouse wake-up function. You can use JP28 to enable or disable this function, which could resume your system from suspend mode with keyboard or mouse. The factory default setting is "Disable" (1-2), and you may enable this function by setting the jumper to 2-3.

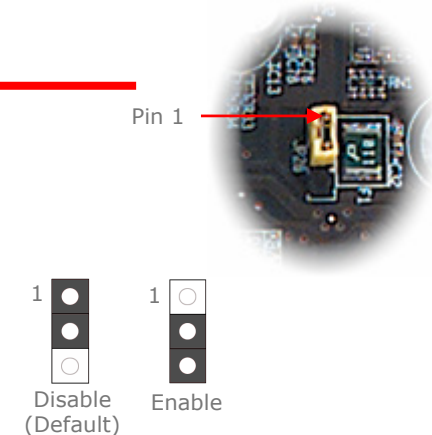
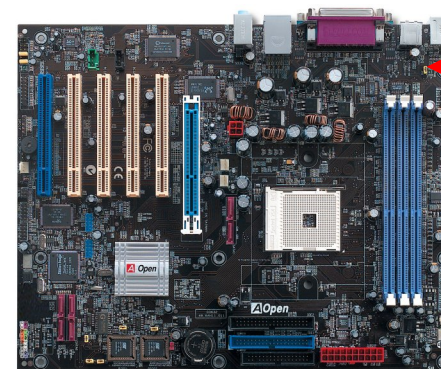

USB 2.0 Connector

This motherboard provides eight USB 2.0 ports to connect USB devices, such as mouse, keyboard, modem, printer, etc. There are four ports on the back panel. You can use proper cables to connect the Front USB connector to USB modules or front panel of chassis.

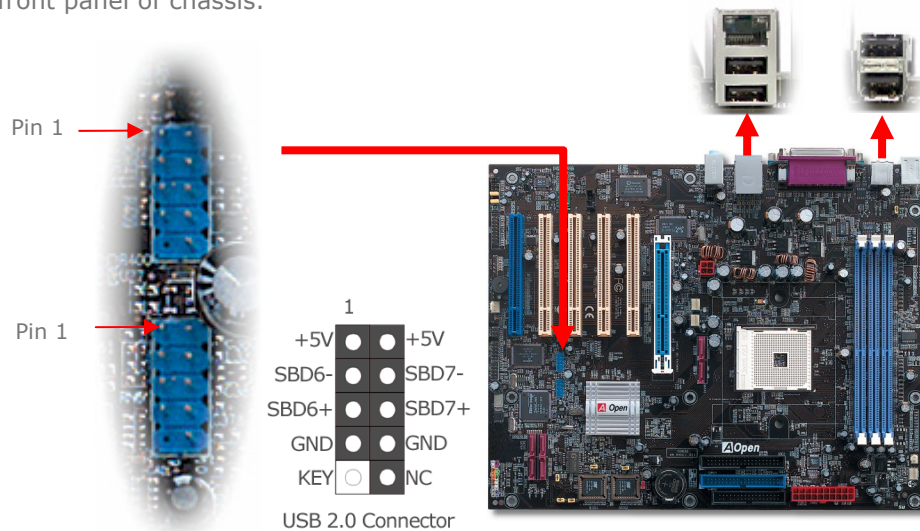

Gigabit LAN onboard (for n250a-FR and n250a-L)

On the strength of Gigabit LAN controller on board, this motherboard provides 10/100/1000 Mbps Ethernet for office and home use (for n250a, it is 10/100 Mbps). The Ethernet RJ45 connector is located on top of USB connectors. The right hand side LED indicates link mode, it lights in orange whenever linking to network. The left hand side LED indicates the transfer mode and it lights in green when data is transferring in 100Mbps (never lights while in 10Mbps), but lights in orange when transferring in Gigabit's mode. To enable or disable this function, you may simply adjust it through BIOS.

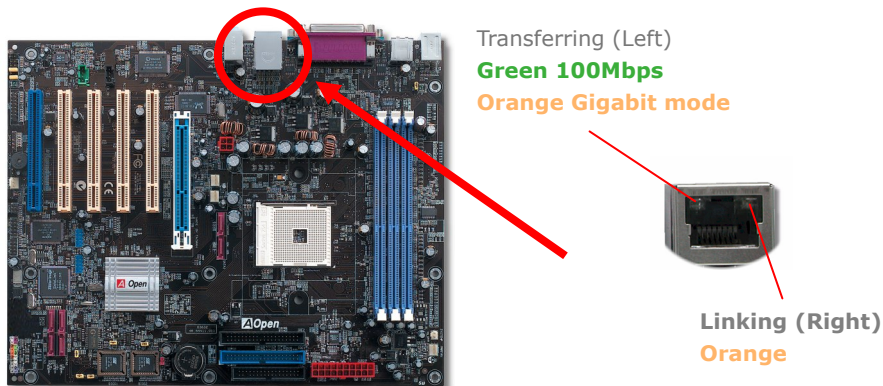

IEEE 1394 Connectors (only for n250a-FR)

This motherboard comes with AGERE 1394 Control Chip onboard, the IEEE 1394 provides data transfer rate up to 400Mb/s, and USB 1.0/1.1 just has 12Mbps. Hence, the IEEE 1394 interface can connect with the devices that need high data transferring performance, such as digital camera, scanner or others IEEE 1394 devices. Please use the proper cable to connect with devices.

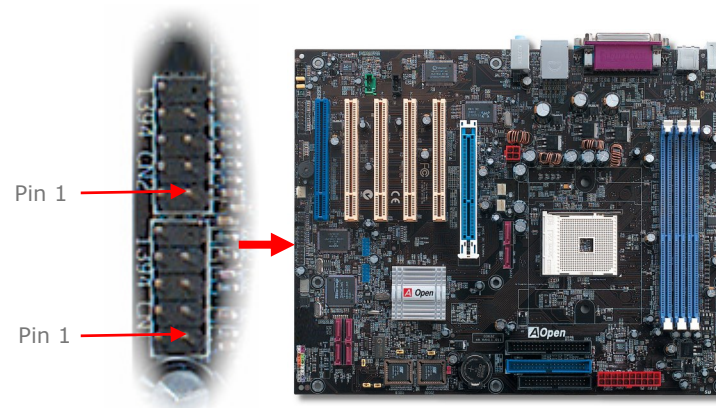

10	SHIED GND	9
+12V(Fused)	+12V(Fused)	
TPB-	TPB+	
GND	GND	
TPA-	TPA+	
2	1	

IEEE 1394 Connector

Warning: Please be noted that Hot-Plug in is not allowed on IEEE 1394 header, because it will burn the IC of the controller and damage the motherboard.

S/PDIF Connector

S/PDIF (Sony/Philips Digital Interface) is a newest audio transfer file format, which provides impressive audio quality through optical fiber and allows you to enjoy digital audio instead of analog audio. Through a specific audio cable, you can connect the S/PDIF connector to other end of the S/PDIF audio module, which bears S/PDIF digital output. Normally there are two S/PDIF outputs as shown, one for RCA connector, the most common one used for consumer audio products, and the other for optical connector with better audio quality. Same as outputs, you can also connect RCA or optical audio products to input connectors on the module and have the voice or music come out from your computer. However, you must have a S/PDIF supported speaker/amplifier/decoder with S/PDIF digital input/output to connect to the S/PDIF digital input/output to make the most out of this function.

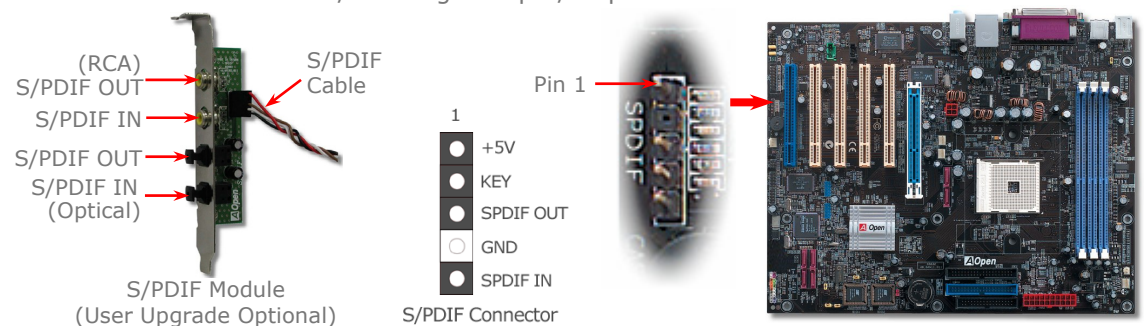



Troubleshooting

If you encounter any trouble to boot your system, follow the procedures accordingly to resolve the problem.

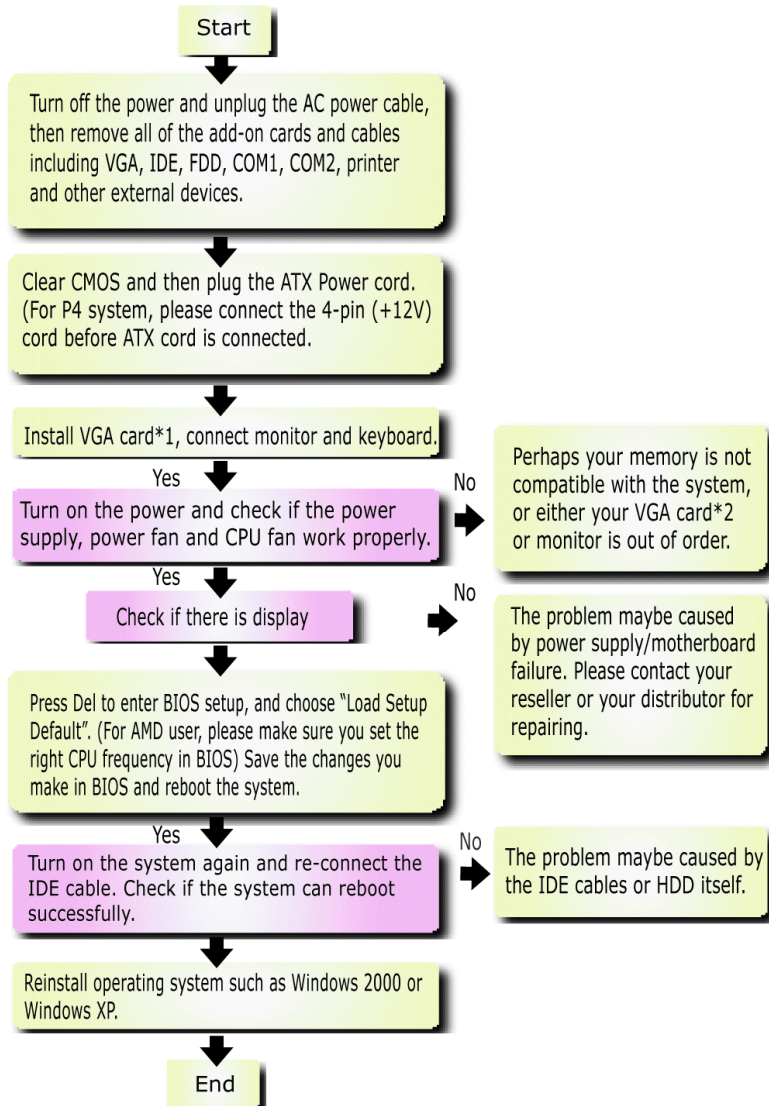

*1 The VGA card is not necessary to be installed if your monitor is connected to the onboard VGA port.
 *2 If you connect to the onboard VGA port and no screen displays, then your onboard VGA device might have problem.

Model name and BIOS version

Model name and BIOS version can be found on upper left corner of first boot screen (POST screen). For example:

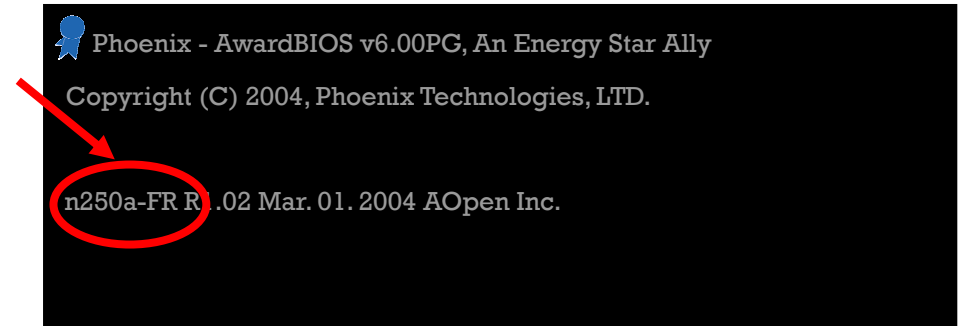

n250a-FR is model name of motherboard; R1.02 is BIOS version

Register Your Motherboard

Thanks for choosing AOpen product, please register this motherboard at <http://club.aopen.com.tw/productreg/> to become a Gold member of Club AOpen, and to ensure high service quality and priority from AOpen. You will also have a chance to play slot machine game to win prize from AOpen. Please prepare the following information before you start: **Model Name, Part Number (P/N), Serial Number (S/N) and Purchase Date.** The Part Number and Serial number are printed on bar code label. You can find this bar code label on the outside packing or on component side of PCB. For example:



Part No.

Serial No.

P/N: 91.88110.201 is part number, **S/N: 91949378KN73** is serial number.

Phoenix-Award BIOS ERROR Message

Beep Sound	Message
1 short(Beep)	System booting is normally.
1 long - 1 short(Beep)	DRAM ERROR
1 long - 2 short(Beep)	Display card or monitor connected error
1 long - 3 short(Beep)	Keyboard Error
Long(Beep) continuous	DRAM hasn't inset correctly.



Technical Support

Dear Customer,

Thanks for choosing AOpen products. We invite you to register at <http://www.aopen.com> to become a Gold Member of Club AOpen so as to ensure quality service in the future. In order to maintain the best service to every customer of us, we recommend you to follow the procedures below and seek help from our branches according to the region you buy the product. With your help, we can then continue to provide efficient and the best quality service to every customer.

Thanks very much for your understanding!

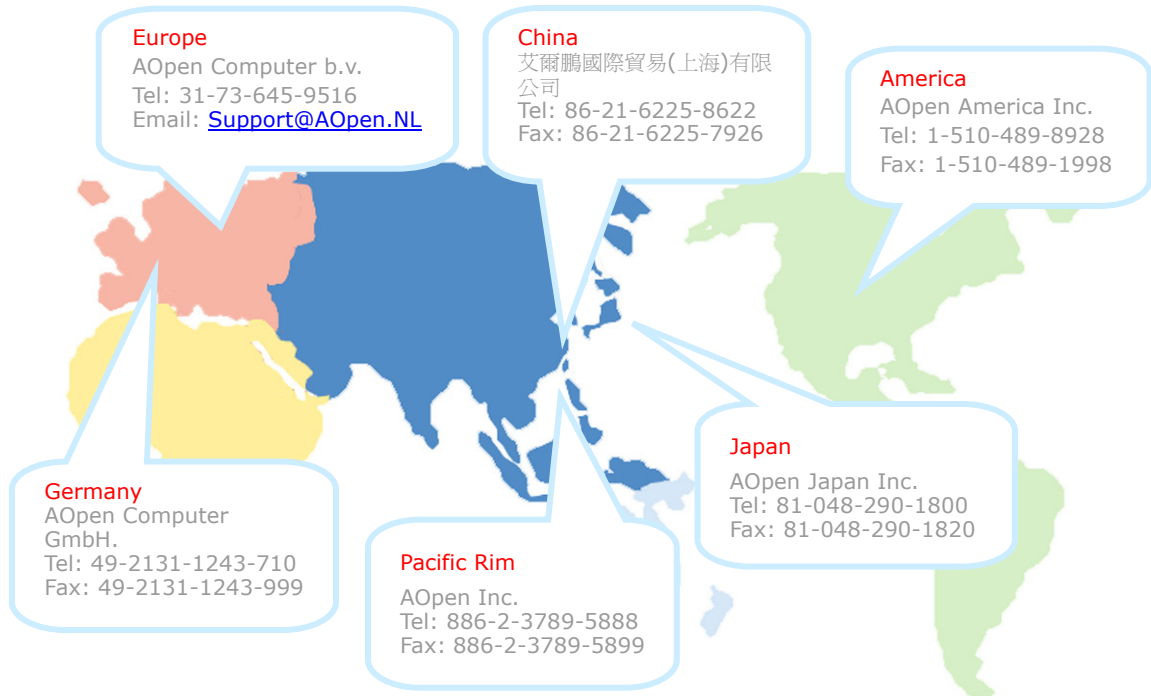

Europe Email: Support@AOpen.NL
Pacific Rim <http://www.aopen.com.tw/tech/default.htm>
China: <http://www.aopen.com.cn/tech/default.htm>
Germany <http://www.aopencom.de/tech/default.htm>
America <http://usa.aopen.com/tech/default.htm>
Japan <http://www.aopen.co.jp/tech/default.htm>

Online Manual: To download manual, please log on and then select your preferred language. Under "Type" directory, choose "Manuals" to go to our manual database. You can also find the manual and EIG in AOpen Bonus Pack.
<http://download.aopen.com.tw/downloads>

Test Report: We recommend you to choose board/card/device from the compatibility test reports for assembling your PC. It may prevent incompatibility problems.
<http://english.aopen.com.tw/tech/report/default.htm>

FAQ: Here we list problems that users often encounter and FAQ (Frequently Asked Questions). You may select your preferred language after log on, and may be able to find a solution to your problem.
<http://club.aopen.com.tw/faq/>

Download Software: After log on and having language selected, you may get the latest updated BIOS/utility and drivers you need under "Type" directory. In most case, newer versions of drivers and BIOS have solved earlier bugs or compatibility problems.
<http://download.aopen.com.tw/downloads>

eForum: AOpen eForum is provided to discuss our products with other users, in which your problem probably had been discussed before or will be answered. After log on, you may select your preferred language under "Multi-language".
<http://club.aopen.com.tw/forum>

Contact Us: Please prepare detail system configuration and error symptom before contacting us. The part number, serial number and BIOS version are also very helpful.

Contact Distributors/Resellers: We sell our products through resellers and integrators. They should know your system configuration very well and should be able to solve your problem efficiently and provide important reference for you.