

**MX46U2-GN**  
**MX46-533GN**  
**Online Manual**

**DOC. NO.: MX46533GN-OL-E0302B**

**Overview**

**Hardware  
Installation**

**Drivers &  
Utilities**

**AWARD  
BIOS Setup**



**Glossary**

**Troubleshooting &  
Technical Support**

## **What's in this manual**

<b>MX46U2-GN / MX46-533GN.....</b>	<b>1</b>
<i>What's in this manual.....</i>	2
<i>You Must Notice.....</i>	7
<i>Before You Start.....</i>	8
<i>Overview.....</i>	9
<i>Feature Highlight .....</i>	10
<i>Quick Installation Procedure .....</i>	14
<i>Motherboard Map .....</i>	15
<i>Block Diagram .....</i>	16
<b>Hardware Installation.....</b>	<b>17</b>
<i>About "User Upgrade Optional" and "Manufacture Upgrade Optional".....</i>	18
<i>CPU Installation.....</i>	19
<i>Enlarged Aluminum Heatsink.....</i>	22
<i>Full-range Adjustable CPU Core Voltage.....</i>	23
<i>CPU and System Fan Connector (with H/W Monitoring).....</i>	25
<i>DIMM Sockets .....</i>	26
<i>DDR 266(PC2100) and DDR 333(PC2700) .....</i>	28
<i>Front Panel Connector.....</i>	29



ATX Power Connector.....	30
AC Power Auto Recovery.....	30
IDE and Floppy Connector.....	31
 ATA/133 Supported.....	33
IrDA Connector.....	34
AGP (Accelerated Graphic Port) Expansion Slot.....	35
Support 10/100 Mbps LAN onboard.....	36
Color Coded Back Panel.....	37
 USB2.0 Connector.....	38
Case Open Connector.....	39
CD Audio Connector.....	40
Front Audio Connector.....	41
JP14 Clear CMOS Data.....	42
STBY LED.....	43
AOpen "Watch Dog Timer".....	44
Battery-less and Long Life Design.....	45
Over-current Protection.....	46
Resetable Fuse.....	47
Low ESR Capacitor.....	48

<b>Phoenix Award BIOS.....</b>	<b>50</b>
<i>About BIOS Function Description.....</i>	<i>51</i>
<i>How To Use Phoenix Award™ BIOS Setup Program.....</i>	<i>52</i>
<i>How To Enter BIOS Setup.....</i>	<i>54</i>
<i>BIOS Upgrade under Windows environment.....</i>	<i>55</i>
<i>Vivid BIOS technology.....</i>	<i>57</i>
<i>The noise is gone!! ---- SilentTek.....</i>	<i>58</i>
<b>Driver and Utility.....</b>	<b>61</b>
<i>Auto-run Menu from Bonus CD.....</i>	<i>61</i>
<i>Installing IDE Driver.....</i>	<i>62</i>
<i>Installing AGP Driver.....</i>	<i>63</i>
<i>Installing VGA Driver.....</i>	<i>64</i>
<i>Installing USB2.0 Driver.....</i>	<i>65</i>
<i>Installing Audio Driver.....</i>	<i>66</i>
<i>Installing LAN Driver.....</i>	<i>67</i>
<i>AOConfig Utility.....</i>	<i>70</i>
<b>Glossary.....</b>	<b>72</b>
<i>AC97 CODEC.....</i>	<i>72</i>
<i>ACPI (Advanced Configuration &amp; Power Interface).....</i>	<i>72</i>



<i>ACR (Advanced Communication Riser)</i> .....	72
<i>AGP (Accelerated Graphic Port)</i> .....	73
<i>AMR (Audio/Modem Riser)</i> .....	73
<i>ATA (AT Attachment)</i> .....	73
<i>BIOS (Basic Input/Output System)</i> .....	74
<i>Bluetooth</i> .....	74
<i>CNR (Communication and Networking Riser)</i> .....	75
<i>DDR (Double Data Rate) RAM</i> .....	75
<i>ECC (Error Checking and Correction)</i> .....	75
<i>EEPROM (Electronic Erasable Programmable ROM)</i> .....	76
<i>EPROM (Erasable Programmable ROM)</i> .....	76
<i>EV6 Bus</i> .....	76
<i>FCC DoC (Declaration of Conformity)</i> .....	76
<i>FC-PGA (Flip Chip-Pin Grid Array)</i> .....	77
<i>FC-PGA2 (Flip Chip-Pin Grid Array)</i> .....	77
<i>Flash ROM</i> .....	77
<i>Hyper Threading</i> .....	77
<i>IEEE 1394</i> .....	78
<i>Parity Bit</i> .....	78

<i>PCI (Peripheral Component Interface) Bus</i> .....	79
<i>PDF Format</i> .....	79
<i>PnP (Plug and Play)</i> .....	79
<i>POST (Power-On Self Test)</i> .....	79
<i>PSB (Processor System Bus) Clock</i> .....	80
<i>RDRAM (Rambus Dynamic Random Access Memory)</i> .....	80
<i>RIMM (Rambus Inline Memory Module)</i> .....	80
<i>SDRAM (Synchronous DRAM)</i> .....	80
<i>SATA (Serial ATA)</i> .....	81
<i>SMBus (System Management Bus)</i> .....	81
<i>SPD (Serial Presence Detect)</i> .....	81
<i>USB 2.0 (Universal Serial Bus)</i> .....	81
<i>VCM (Virtual Channel Memory)</i> .....	82
<i>Wireless LAN – 802.11b</i> .....	82
<i>ZIP file</i> .....	82
<b>Troubleshooting</b> .....	<b>83</b>
<b>Technical Support</b> .....	<b>87</b>
<b>Product Registration</b> .....	<b>90</b>
<b>How to Contact Us</b> .....	<b>91</b>



## **You Must Notice**



Adobe, the Adobe logo, Acrobat is trademarks of Adobe Systems Incorporated.

AMD, the AMD logo, Athlon and Duron are trademarks of Advanced Micro Devices, Inc.

Intel, the Intel logo, Intel Celeron, Pentium II, Pentium III and Pentium 4 are trademarks of Intel Corporation.

Microsoft, Windows, and Windows logo are either registered trademarks or trademarks of Microsoft Corporation in the United States and/or other countries.

All product and brand names used on this manual are used for identification purposes only and may be the registered trademarks of their respective owners.

All of the specifications and information contained in this manual are subject to change without notice. AOpen reserves the right to revise this publication and to make reasonable changes. AOpen assumes no responsibility for any errors or inaccuracies that may appear in this manual, including the products and software described in it.

**This documentation is protected by copyright law. All rights are reserved.**

**No part of this document may be used or reproduced in any form or by any means, or stored in a database or retrieval system without prior written permission from AOpen Corporation.**

**Copyright© 1996-2003, AOpen Inc. All Rights Reserved.**

## **Before You Start**



This Online Manual will introduce to the user how this product is installed. All useful information will be described in later chapters. Please keep this manual carefully for future upgrades or system configuration changes. This Online Manual is saved in [PDF format](#), we recommend using Adobe Acrobat Reader 4.0 for online viewing, it is included in [Bonus CD](#) or you can get free download from [Adobe web site](#).

Although this Online Manual is optimized for screen viewing, it is still capable for hardcopy printing, you can print it by A4 paper size and set 2 pages per A4 sheet on your printer. To do so, choose **File > Page Setup** and follow the instruction of your printer driver.

Thanks for the help of saving our earth.



## Overview

Thank you for choosing AOpen MX46U2-GN / MX46-533GN motherboard. MX46U2-GN / MX46-533GN is Intel® Socket 478 motherboard (M/B) based on the micro-ATX form factor featuring the [SIS 650GX chipset](#) (MX46U2-GN) and [SIS 651 chipset](#) (MX46-533GN). As high performance chipset built in the M/B, MX46U2-GN supports Intel® Socket 478 Pentium® 4 (Willamette / Northwood) and 400MHz Front Side Bus (FSB) clock. MX46-533GN supports Intel® Socket 478 Pentium® 4 (Willamette / Northwood) and 400MHz/533MHz Front Side Bus (FSB) clock. In the AGP performance, it has one AGP slot and supports [AGP](#) 4X/2X/1X modes. According to different customer's requirements, MX46U2-GN supports [DDR200](#) and [DDR 266](#) up to 2GB maximum. MX46-533GN supports [DDR333](#), [DDR266](#) and [DDR200](#) up to 2GB maximum. The onboard IDE controller supports [Ultra DMA](#) 33/66/100/133 mode. More than that, on the strength of Realtek 8101L LAN controller on board, which is a highly-integrated Platform LAN Connect device, it provides 10/100M bps Ethernet for office and home use. More than that, both motherboards support [USB 2.0](#) with a fancy speed of up to 480Mbps Besides, MX46U2-GN / MX46-533GN has an [AC97 CODEC](#) chipset onboard providing high performance and magic surround stereo sound to let people enjoy working with it. Now, let's enjoy all features from AOpen MX46U2-GN / MX46-533GN motherboard.

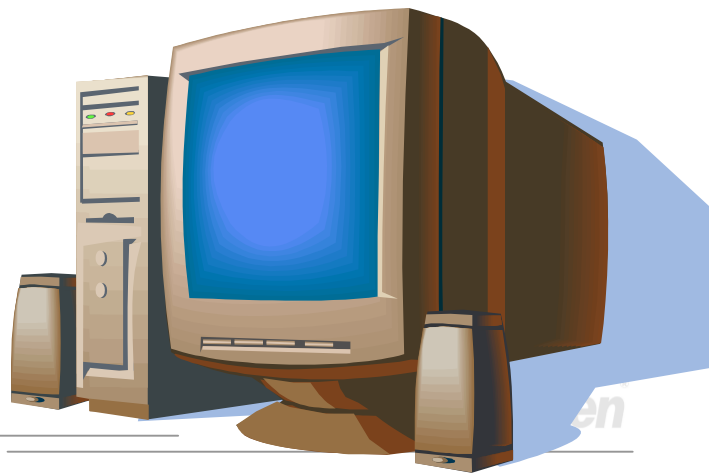

## **Feature Highlight**

### **CPU**

MX46U2-GN supports Intel® Socket 478 Pentium® 4 (Willamette / Northwood) 1.4GHz~2.8GHz+ with 400MHz Front Side Bus (FSB) designed for Socket 478 technology and MX46-533GN with 400MHz/533MHz Front Side Bus (FSB).

### **Chipset**

#### **MX46U2-GN**

This motherboard is equipped with SIS 650GX chipset. SIS 650 IGUI Host Memory Controller integrates a high performance host interface for Intel Pentium 4 processor, a high performance 2D/3D Graphic Engine, a high performance memory controller and an AGP 4X interface.

#### **MX46-533GN**

This motherboard is equipped with SIS 651 chipset. SIS 651 IGUI Host Memory Controller integrates a high performance host interface for Intel Pentium 4 processor, a high performance 2D/3D Graphic Engine, a high performance memory controller and an AGP 4X interface. SiS651 Host Interface features the AGTL & AGTL+ compliant bus driver technology with integrated on-die termination to support Intel Pentium 4 series processors with FSB 100MHz and up to 133MHz. SiS651 also can support external AGP slot with AGP 1X/2X/4X capability and Fast Write Transactions.

The South Bridge SIS 962L MuTIOL Media I/O integrates one Universal Serial Bus 2.0 Host Controllers, the Audio Controller with AC97 Interface, three Universal Serial Bus 1.1 Host Controllers and the IDE Master/Slave controllers. The PCI to LPC bridge, I/O Advanced

Programmable Interrupt Controller, legacy system I/O and legacy power management functionalities are integrated as well.

## Expansion Slots

Including three 32-bit/33MHz PCI, one AGP 1X/2X/4X slots. The [PCI](#) local bus throughput can be up to 132MB/s. The [Accelerated Graphics Port \(AGP\)](#) specification provides a new level of video display sophistication and speed. The AGP video cards support data transfer rate up to 1056MB/s. MX46U2-GN / MX46-533GN motherboard includes one AGP expansion slot for a bus mastering AGP graphic card. For AD and SBA signaling, MX46U2-GN / MX46-533GN motherboard can support 4X mode. Of three PCI slots provided, all of them are master PCI slots with arbitration and decoding for all integrated functions and LPC bus.

## Memory

Provides two 184-pin [DDR](#) DIMM sockets that support up to 2GB of DDR333 (MX46-533GN), DDR266 and DDR200.

## Watch Dog Timer

Includes AOpen “Watch Dog Timer” function that can auto-reset system in 4.8 seconds when you fail to system overclocking.

## 1MHz Stepping CPU Frequency Adjustment

Provides “1MHz Stepping Frequency Adjustment” function in the BIOS. This magic function allows you to adjust CPU [FSB](#) frequency from 100~248MHz by 1MHz stepping adjustment, and helps your system get maximum performance.

## LAN Port

On the strength of Realtek 8101L LAN controller on board, which is a highly-integrated Platform LAN Connect device, it provides 10/100 Mbps Ethernet for office and home use.

## Ultra DMA 33/66/100/133 Bus Master IDE

Comes with an on-board PCI Bus Master IDE controller with two connectors that support four IDE devices in two channels, supports [Ultra DMA](#) 33/66/100/133, PIO Modes 3 and 4 and Bus Master IDE DMA Mode 5, and supports Enhanced IDE devices.

## On-board AC'97 Sound

MX46U2-GN / MX46-533GN uses RealTek [AC97](#) sound chip. This on-board audio includes a complete audio recording and playback system.

## Six USB2.0 Connectors

Provides four ports on the back panel, one connector on the board for USB2.0 interface devices, such as mouse, keyboard, modem, scanner, etc.

### **Power Management/Plug and Play**

Supports the power management function that conforms to the power-saving standards of the U.S. Environmental Protection Agency (EPA) Energy Star program. It also offers [Plug-and-Play](#), which helps save users from configuration problems, thus making the system much user-friendlier.

### **Hardware Monitoring Management**

Supports CPU or system fans status, temperature and voltage monitoring and alert, through the on-board hardware monitor module.

### **Enhanced ACPI**

Fully implement the [ACPI](#) standard for Windows® 98/ME/2000 series compatibility, and supports Soft-Off, STR (Suspend to RAM, S3), STD (Suspend to Disk, S4) features.

### **Super Multi-I/O**

Provides two high-speed UART compatible serial ports and one parallel port with EPP and ECP capabilities. UART can also be directed from COM1 to the Infrared Module for the wireless connections.

## **Quick Installation Procedure**

This page gives you a quick procedure on how to install your system. Follow each step accordingly.

1. [Installing CPU and Fan](#)
2. [Installing System Memory \(DIMM\)](#)
3. [Connecting Front Panel Cable](#)
4. [Connecting IDE and Floppy Cable](#)
5. [Connecting ATX Power Cable](#)
6. [Connecting Back Panel Cable](#)
7. [Power-on and Load BIOS Setup Default](#)
8. [Setting CPU Frequency](#)
9. Reboot
10. Installing Operating System (such as Windows 98)
11. [Installing Driver and Utility](#)

### Motherboard Map

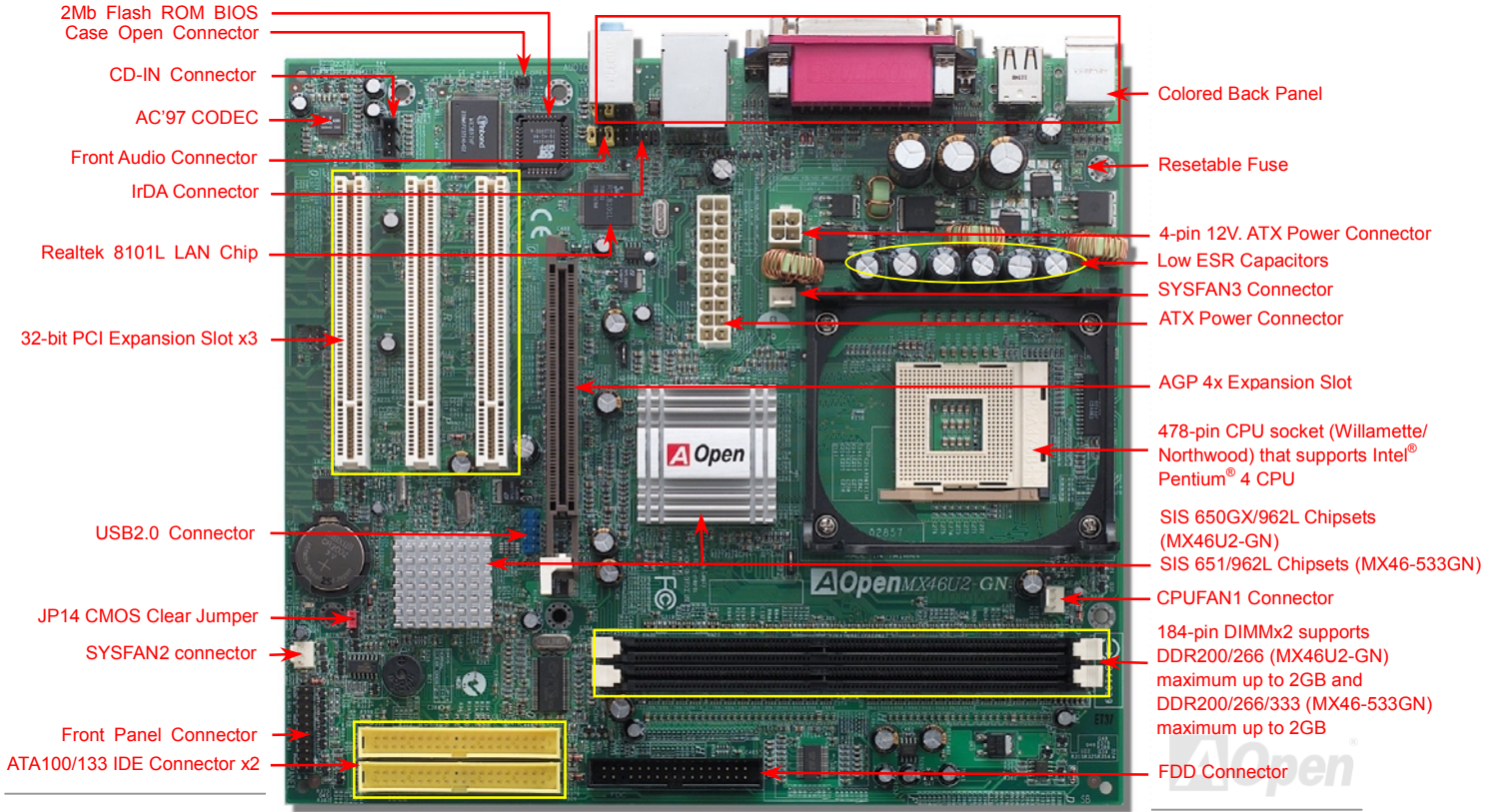

## Block Diagram

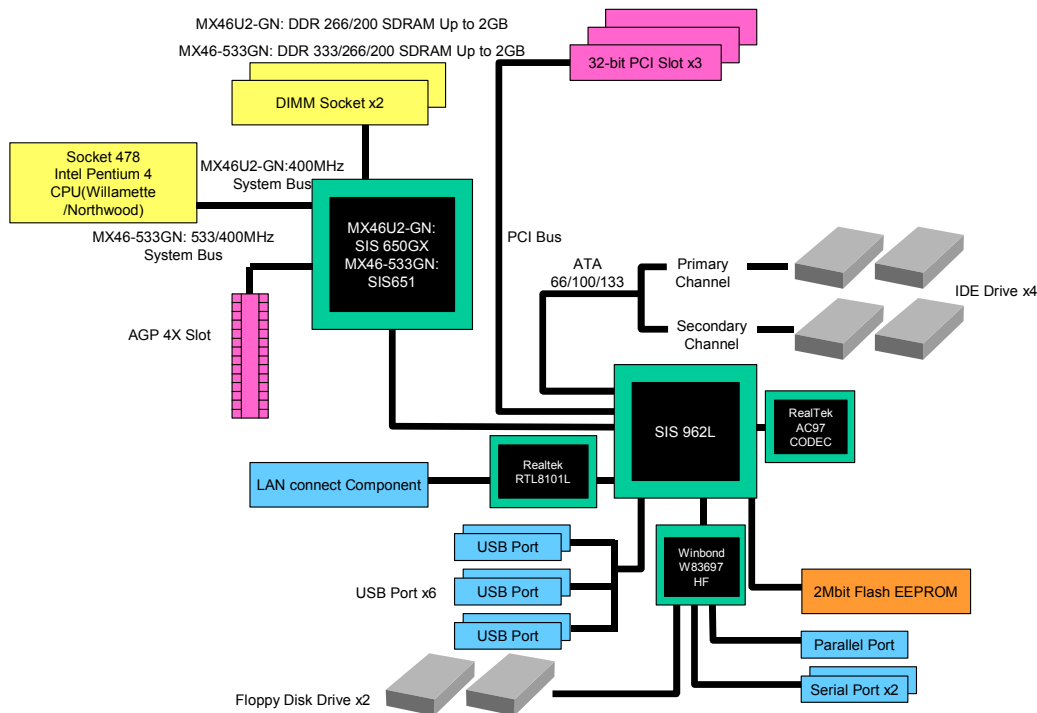



# Hardware Installation

This chapter describes jumpers, connectors and hardware devices of this motherboard.



**Note:** *Electrostatic discharge (ESD) can damage your processor, disk drives, expansion boards, and other components. Always observe the following precautions before you install a system component.*

1. *Do not remove a component from its protective packaging until you are ready to install it.*
2. *Wear a wrist ground strap and attach it to a metal part of the system unit before handling a component. If a wrist strap is not available, maintain contact with the system unit throughout any procedure requiring ESD protection.*

## About “User Upgrade Optional” and “Manufacture Upgrade Optional”...

When you read this online manual and start to assemble your computer system, you may notice that some of the functions are marked as “User Upgrade Optional” or “Manufacture Upgrade Optional”. Although all of AOpen’s motherboards have included many amazing and powerful features, sometimes not every user is familiar with these powerful features. As a result of this we define features that can be upgraded by users as “User Upgrade Optional”. You can upgrade these functions by purchasing additional devices. As for functions that cannot be upgraded by users, we define them as “Manufacture Upgrade Optional”. If need be, you can contact our local distributors or resellers to purchase “Manufacture Upgrade Optional” components, and again you are also welcome to visit our official website at [english.aopen.com.tw](http://english.aopen.com.tw) for detail information.



## CPU Installation

This motherboard supports Intel® Pentium 4 Socket 478 series CPU (Willamette / Northwood). Be careful of CPU orientation when you plug it into CPU socket.

1. Pull up the CPU socket lever and up to 90-degree angle.
2. Locate Pin 1 in the socket and look for mark on the CPU upper interface. Match Pin 1 and cut edge, then insert the CPU into the socket.

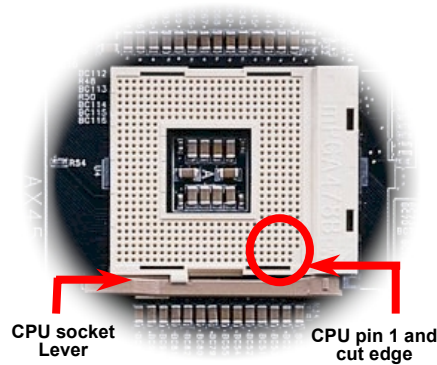
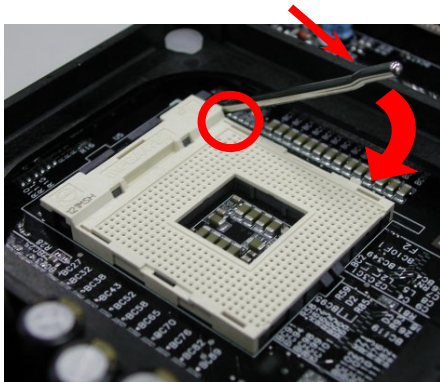

Note: Those pictures are for example only; they may not look the same with the motherboard you purchased.

3. Press down the CPU socket lever and finish CPU installation.

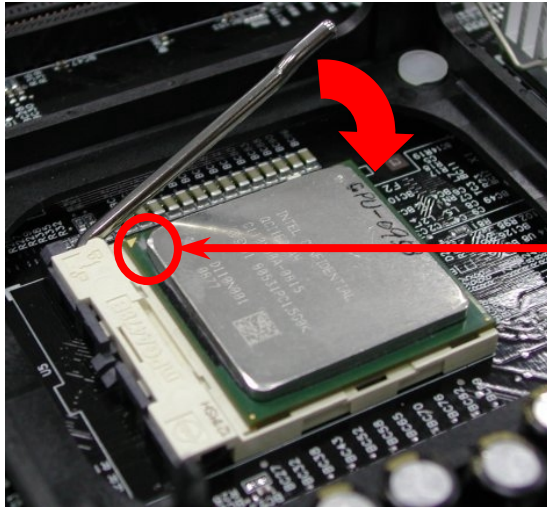

CPU cut edge

**Note:** If you do not match the CPU socket Pin 1 and CPU cut edge well, you may damage the CPU.

**Note:** This socket supports Micro-FC-PGA2 package CPU, which is the latest CPU package developed by Intel. Other forms of CPU package are impossible to be fitted in.

Note: This picture is for example only; it may not look the same with the motherboard you purchased.

## CPU Fan Installation

This motherboard comes with a retention module attached on the CPU socket when shipped, we strongly recommend you to install AOpen special designed CPU Fan as shown below on the retention module for better heat dissipation. Please install the CPU Fan correctly as the following pictures shown.

1. Gently put the CPU Fan down on the retention module with clips aligning correctly to the four corners.

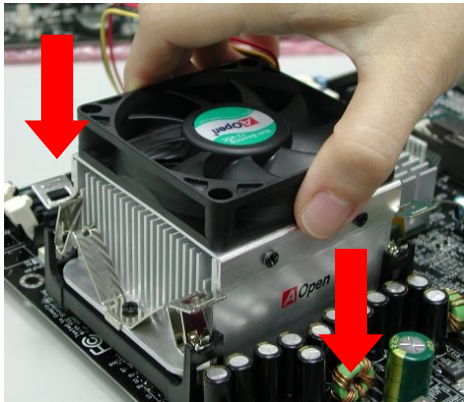

2. Pressing down the four clips with force one by one on the retention module.

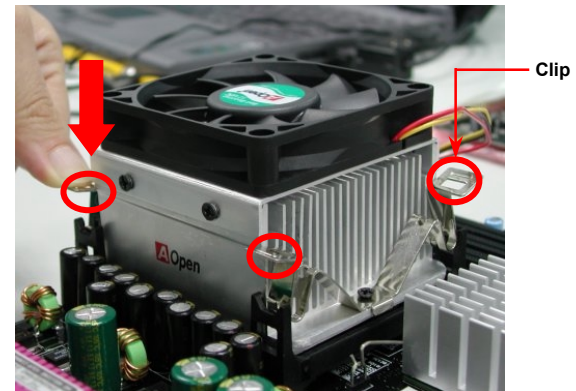

## **Enlarged Aluminum Heatsink**

Cool down CPU and Chipset are important for system reliability. Enlarged aluminum heat sink provides better heat consumption especially when you are trying to over-clock the CPU.

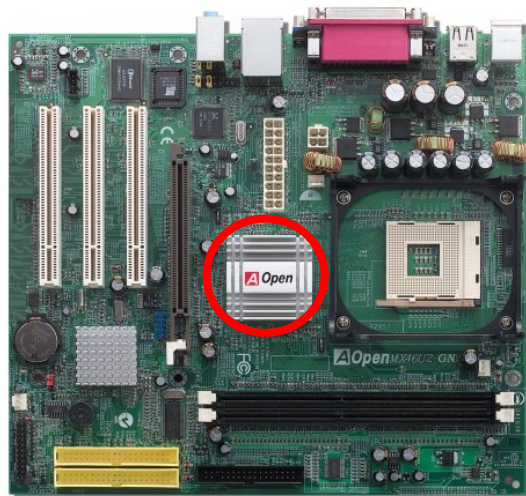

## Full-range Adjustable CPU Core Voltage

This function is dedicated to overclockers and supports Adjustable CPU Core Voltage from 1.10V to 1.85V. However, this motherboard can also automatically detect CPU VID signal and generate proper CPU core voltage.

## Setting CPU Frequency

### BIOS Setup > Frequency/Voltage Control > CPU Clock Setting

This motherboard is CPU jumper-less design, you can set CPU frequency through the BIOS setup, and no jumpers or switches are needed. The default setting is "1MHz Stepping Adjustment". You can adjust the FSB from "CPU Host/SDRAM/PCI Clock" for overclocking.

$$\text{Core Frequency} = \text{CPU FSB Clock} * \text{CPU Ratio}$$

$$\text{PCI Clock} = \text{CPU FSB Clock} / \text{Clock Ratio}$$

$$\text{AGP Clock} = \text{PCI Clock} * 2$$

CPU Ratio	8x, 10x... 22x, 23x, 24x, 25x
CPU FSB (By Manual)	100MHz(MX46U2-GN), 133MHz(MX46-533GN)

Northwood CPU	CPU Core Frequency	FSB Clock	System Bus	Ratio
Pentium 4 1.6G	1600MHz	100MHz	400MHz	16x
Pentium 4 1.6G	1600MHz	133MHz	533MHz	12x
Pentium 4 1.7G	1700MHz	133MHz	533MHz	13x
Pentium 4 1.8G	1800MHz	100MHz	400MHz	18x
Pentium 4 2.0G	2000MHz	100MHz	400MHz	20x
Pentium 4 2.2G	2200MHz	100MHz	400MHz	22x
Pentium 4 2.26G	2260MHz	133MHz	533MHz	17x
Pentium 4 2.4G	2400MHz	100MHz	400MHz	24x
Pentium 4 2.4G	2400MHz	133MHz	533MHz	18x
Pentium 4 2.53G	2530MHz	133MHz	533MHz	19x
Pentium 4 2.66G	2660MHz	133MHz	533MHz	20x
Pentium 4 2.8G	2800MHz	133MHz	533MHz	21x

Willamette CPU	CPU Core Frequency	FSB Clock	System Bus	Ratio
Pentium 4 1.5G	1500MHz	100MHz	400MHz	15x
Pentium 4 1.6G	1600MHz	100MHz	400MHz	16x
Pentium 4 1.7G	1700MHz	100MHz	400MHz	17x
Pentium 4 1.8G	1800MHz	100MHz	400MHz	18x
Pentium 4 1.9G	1900MHz	100MHz	400MHz	19x
Pentium 4 2.0G	2000MHz	100MHz	400MHz	20x

Celeron CPU	CPU Core Frequency	FSB Clock	System Bus	Ratio
1.7G	1700MHz	100MHz	400MHz	17x
1.8G	1800MHz	100MHz	400MHz	18x

**Warning:** SIS 651/650GX chipsets support maximum 533/400MHz (100MHz\*4) system bus and 66MHz AGP clock. higher clock setting may cause serious system damage.

**Note:** Since the latest processor, Northwood, would detect the clock ratio automatically, you may not be able to adjust the clock ratio in BIOS manually.



## CPU and System Fan Connector (with H/W Monitoring)

Plug in the CPU fan cable to the 3-pin **CPUFAN1** connector. If you have chassis fan, you can also plug it on **SYSFAN2** or **SYSFAN3** connector.

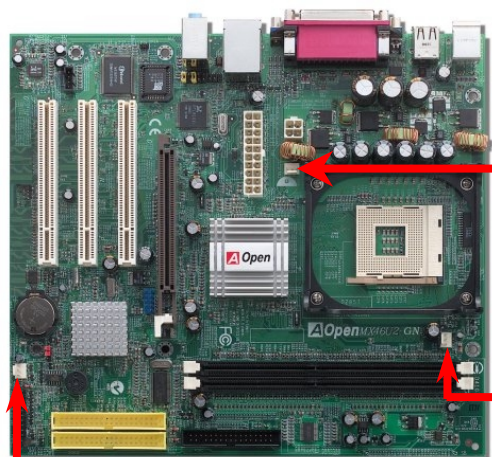

SYSFAN3 Connector



CPUFAN1 Connector



SYSFAN2 Connector

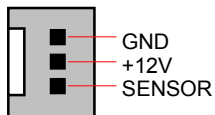
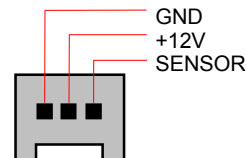

**Note:** Some CPU fans do not have sensor pin, so that they cannot support hardware monitoring function.

## **DIMM Sockets**

This motherboard has two 184-pin [DDR DIMM](#) sockets that allow you to install DDR333, DDR266 memory or DDR200 memory up to 2GB.

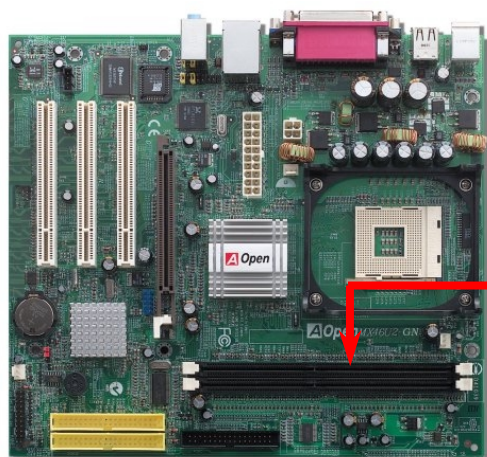

DIMM1  
DIMM2

## How to Install Memory Modules

Please follow the procedure as shown below to finish memory installation.

1. Make sure the DIMM module's pin face down and match the socket's size as depicted below.

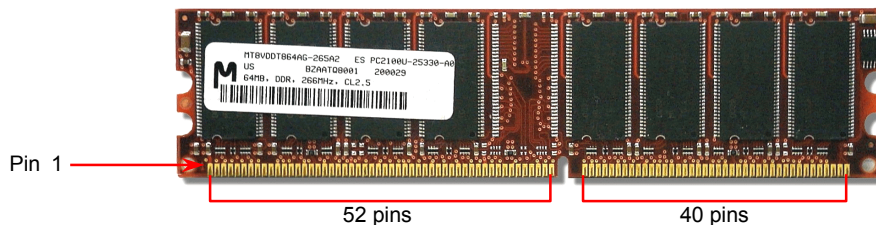

2. Insert the module straight down to the DIMM slot with both hands and press down firmly until the DIMM module is securely in place.

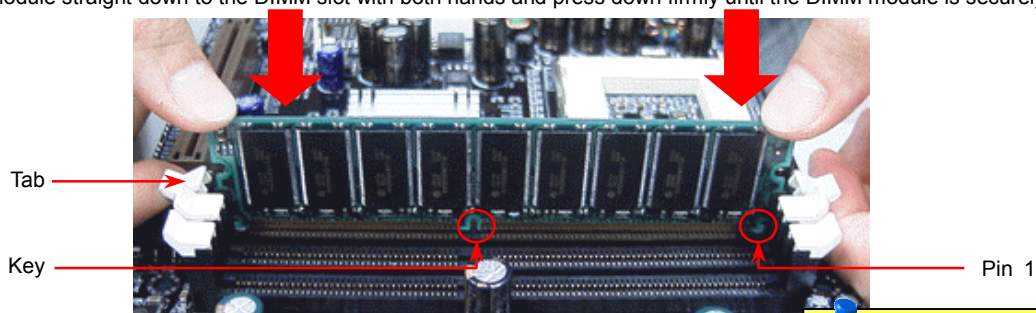

3. Repeat step 2 to finish additional DIMM modules installation.

**Note:** The tabs of the DIMM slot will close-up to hold the DIMM in place when the DIMM touches the slot's bottom.

**DDR 266(PC2100) and DDR 333(PC2700)**

DDR SDRAM utilizes the existing SDRAM infrastructure and technology while doubling the nominal bandwidth available to systems. To put it in a simple way, DDR SDRAM is like data going along a two lane highway, while at the same time data in traditional SDRAM go along a one way street. Therefore, it is a more advanced technology that provides a great overall improvement in system performance. DDR266 (PC2100) runs two times faster than the traditional PC133 SDRAM with the speed of Front Side Bus (FSB) up to 266MHz. ( $2 \times 133 = 266$ ). And DDR333 (PC2700) is running at 333MHz FSB. Both PC2100 and PC2700 are a new naming standard for speed of DDR 266 and DDR 333, representing their theoretical speeds of the RAM. The theoretical transfer rate of DDR 266 (PC2100) is 2.1GB/s and 2.7GB/s is for DDR 333 (PC2700).

## Front Panel Connector

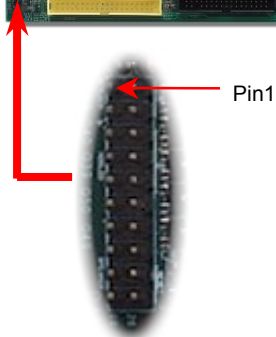

Attach the power LED, Keylock, speaker, power and reset switch connectors to the corresponding pins. If you enable “Suspend Mode” item in BIOS Setup, the ACPI & Power LED will keep flashing while the system is in suspend mode.

Locate the power switch cable from your ATX housing. It is 2-pin female connector from the housing front panel. Plug this connector to the soft-power switch connector marked **SPWR**.

Suspend Type	ACPI LED
Power on Suspend (S2) or Suspend to RAM (S3)	Flashing for every second
Suspend to Disk (S4)	The LED will be turned off

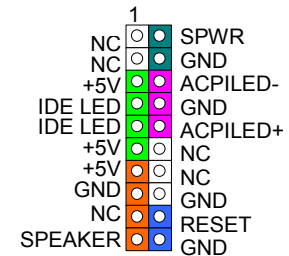
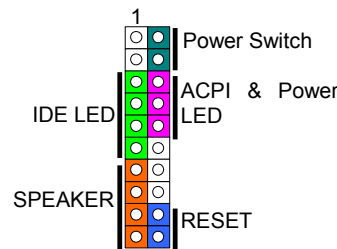

## ATX Power Connector

This motherboard comes with a 20-pin and 4-pin ATX power connector. Make sure you plug in the right direction. We strongly recommend you to connect the 4-pin 12V ATX connector before connecting the 20-pin ATX power connector and use standard power supply specially designed for Pentium 4 system.

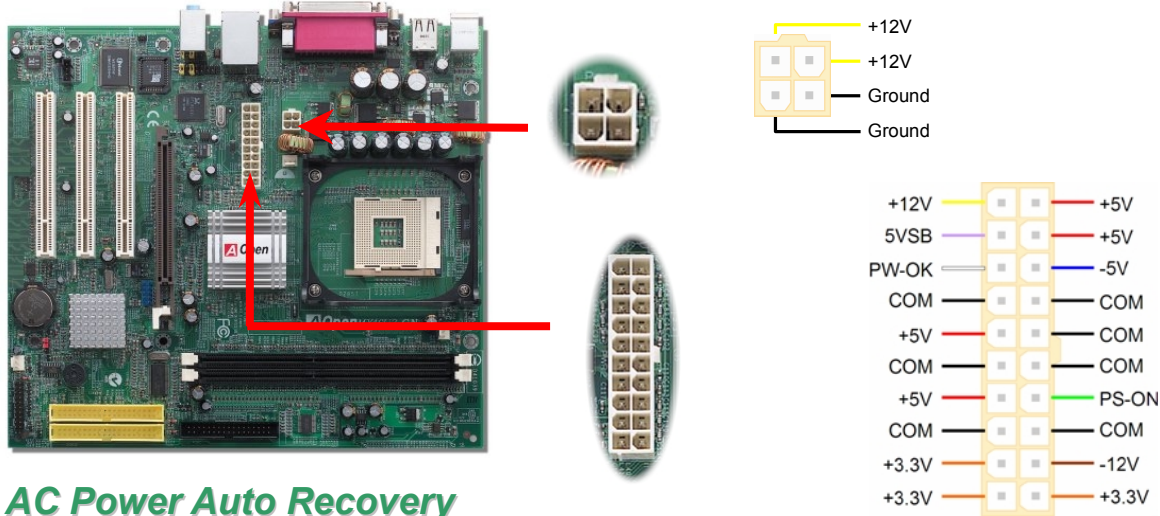

## AC Power Auto Recovery

A traditional ATX system should remain at power off stage when AC power resumes from power failure. This design is inconvenient for a network server or workstation, without an UPS, that needs to keep power-on. This motherboard implements an AC Power Auto Recovery function to solve this problem.



## IDE and Floppy Connector

Connect 34-pin floppy cable and 40-pin IDE cable to floppy connector FDD and IDE connector. Be careful of the pin1 orientation. Wrong orientation may cause system damage.

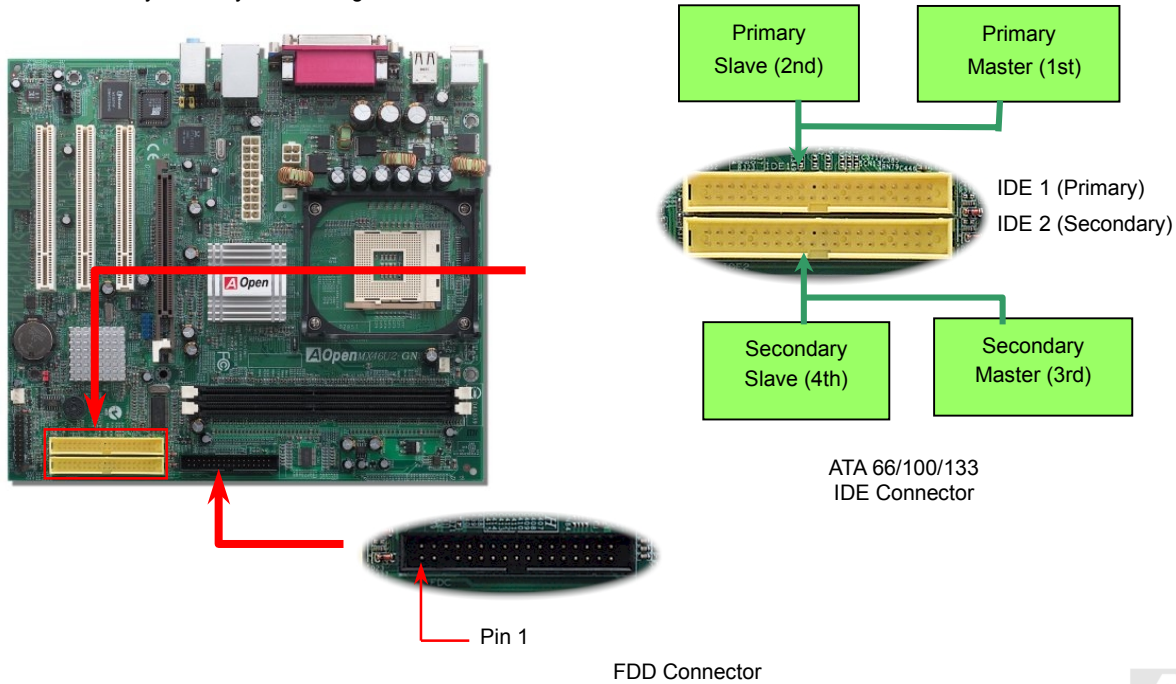

IDE1 is also known as the primary channel and IDE2 as the secondary channel. Each channel supports two IDE devices that make a total of four devices. In order to work together, the two devices on each channel must be set differently to **Master** and **Slave** mode. Either one can be the hard disk or the CDROM. The setting as master or slave mode depends on the jumper on your IDE device, so please refer to your hard disk and CDROM manual accordingly.

**Tip:**

1. For better signal quality, it is recommended to set the far end side device to master mode and follow the suggested sequence to install your new device. Please refer to above diagram
2. To achieve the best performance of Ultra DMA 66/100/133 hard disks, a special **80-wires IDE cable** for Ultra DMA 66/100/133 is required.

**Warning:** The specification of the IDE cable is a maximum of 46cm (18 inches); make sure your cable does not exceed this length.





## ATA/133 Supported

This motherboard supports [ATA66](#), [ATA100](#) or [ATA133](#) IDE devices. Following table lists the transfer rate of IDE PIO and DMA modes. The IDE bus is 16-bit, which means every transfer is two bytes. As the hard drive industry introduces faster and higher capacity hard drives, the current Ultra ATA/100 interface causes a data bottleneck between the drive and the host computer. To avoid this problem, hard disk manufacturers have introduced the new Ultra ATA-133 interface technology. Compared to traditional ATA/100, ATA/133 has up to 33 percent increase in interface speed with transfer rate of 133MB/s. ATA/133 performance is ideal for new operating systems, such as Window XP, that demand more storage space and faster data transfer rates from more responsive computing experiences.

To make good use of this new technology and enjoy its best performance, we recommend you to pair your system with a hard disk equipped with ATA/133 technology so that your system's need for speed on this motherboard can be satisfied.

Mode	Clock Period	Clock Count	Cycle Time	Data Transfer Rate
PIO mode 0	30ns	20	600ns	$(1/600\text{ns}) \times 2\text{byte} = 3.3\text{MB/s}$
PIO mode 1	30ns	13	383ns	$(1/383\text{ns}) \times 2\text{byte} = 5.2\text{MB/s}$
PIO mode 2	30ns	8	240ns	$(1/240\text{ns}) \times 2\text{byte} = 8.3\text{MB/s}$
PIO mode 3	30ns	6	180ns	$(1/180\text{ns}) \times 2\text{byte} = 11.1\text{MB/s}$
PIO mode 4	30ns	4	120ns	$(1/120\text{ns}) \times 2\text{byte} = 16.6\text{MB/s}$
DMA mode 0	30ns	16	480ns	$(1/480\text{ns}) \times 2\text{byte} = 4.16\text{MB/s}$
DMA mode 1	30ns	5	150ns	$(1/150\text{ns}) \times 2\text{byte} = 13.3\text{MB/s}$
DMA mode 2	30ns	4	120ns	$(1/120\text{ns}) \times 2\text{byte} = 16.6\text{MB/s}$
ATA 66	30ns	2	60ns	$(1/60\text{ns}) \times 2\text{byte} \times 2 = 66\text{MB/s}$
ATA 100	20ns	2	40ns	$(1/40\text{ns}) \times 2\text{byte} \times 2 = 100\text{MB/s}$
ATA 133	15ns	2	30ns	$(1/30\text{ns}) \times 2\text{byte} \times 2 = 133\text{MB/s}$

## IrDA Connector

The IrDA connector can be configured to support wireless infrared module, with this module and application software such as Laplink or Windows 95 Direct Cable Connection, the user can transfer files to or from laptops, notebooks, PDA devices and printers. This connector supports HPSIR (115.2Kbps, 2 meters) and ASK-IR (56Kbps).

Install the infrared module onto the **IrDA** connector and enable the infrared function from BIOS Setup, UART Mode. Make sure that you plug in the IrDA connector with correct orientation.

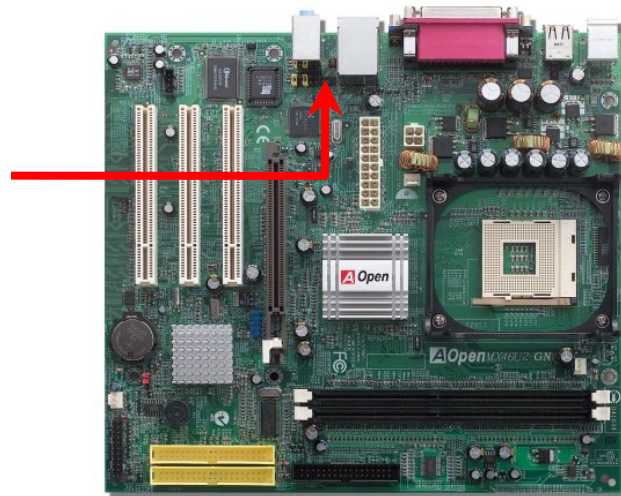
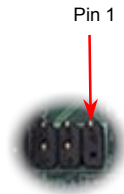
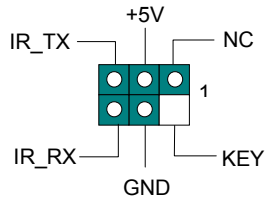

## AGP (Accelerated Graphic Port) Expansion Slot

This model provides an [AGP](#) 4x slot. The AGP 4x is a bus interface targeted for high-performance 3D graphic. AGP supports only memory read/write operation and single-master single-slave one-to-one only. AGP uses both rising and falling edge of the 66MHz clock, for 2X AGP, the data transfer rate is  $66\text{MHz} \times 4\text{bytes} \times 2 = 528\text{MB/s}$  and AGP 4x mode,  $66\text{MHz} \times 4\text{bytes} \times 4 = 1056\text{MB/s}$ .

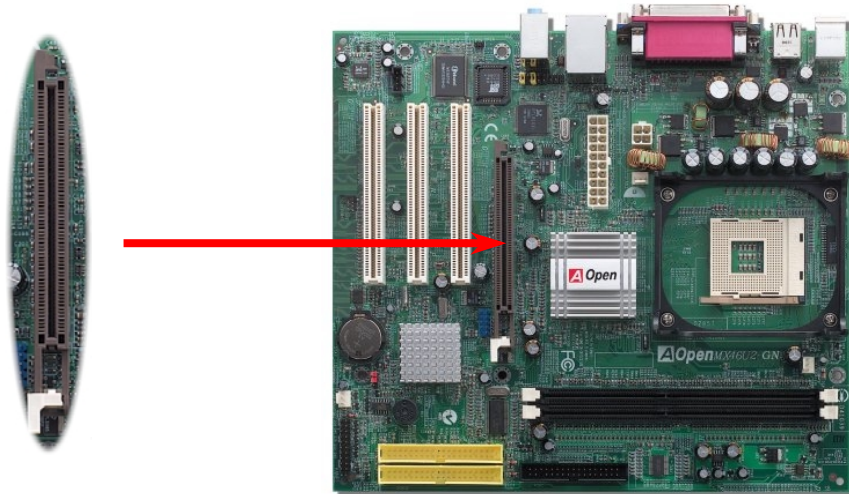

## **Support 10/100 Mbps LAN onboard**

On the strength of Realtek 8101L LAN controller on board, which is a highly-integrated Platform LAN Connect device, it provides 10/100Mbps Ethernet for office and home use, the Ethernet RJ45 connector is located on top of USB connectors. The orange LED indicates the link mode, it lights when linking to network and blinking when transferring data. The green LED indicates the transfer mode, and it lights when data is transferring in 100Mbps mode. To enable or disable this function, you may simply adjust it through BIOS.

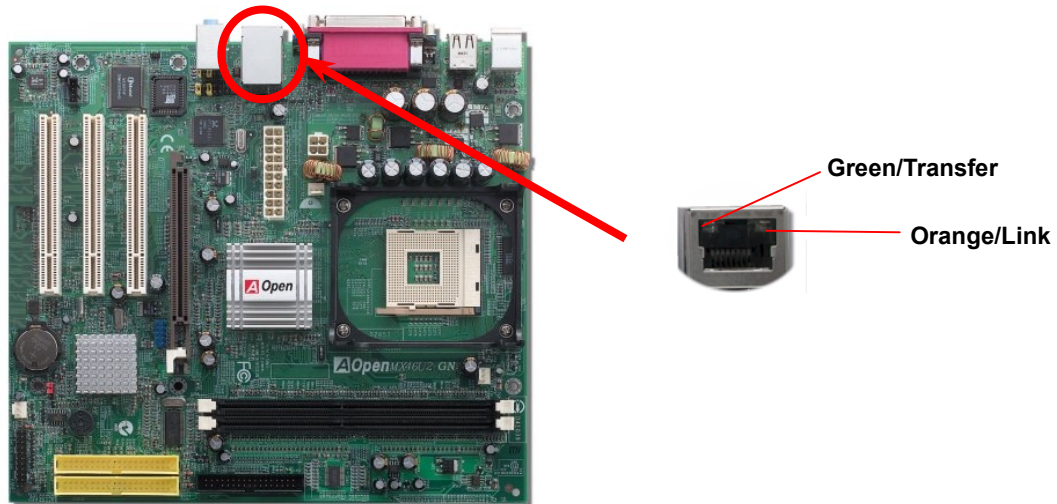

## Color Coded Back Panel

The onboard I/O devices are PS/2 Keyboard, PS/2 Mouse, RJ-45 LAN Connector, COM1, VGA, Printer, [USB](#), and AC97 sound ports. The view angle of drawing shown here is from the back panel of the housing.

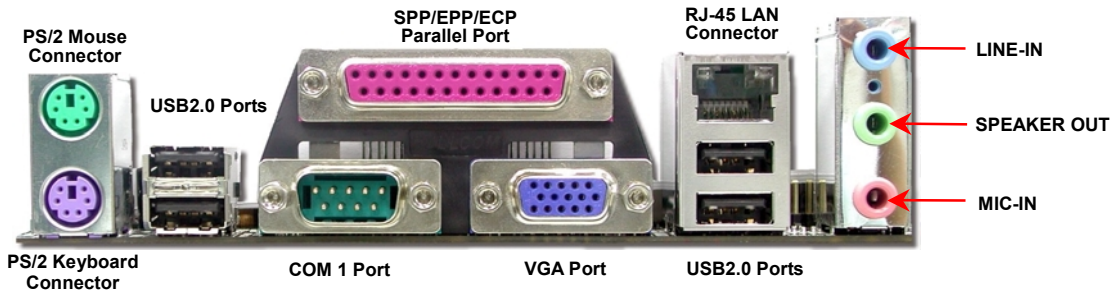

PS/2 Keyboard:	For standard keyboard, which is using a PS/2 plug.
PS/2 Mouse:	For PC-Mouse, which is using a PS/2 plug.
USB Port:	Available for connecting USB devices.
Parallel Port:	To connect with SPP/ECP/EPP printer.
COM1/COM2 Port:	To connect with pointing devices, modem or others serial devices.
RJ-45 LAN connector	To connect Ethernet for home or office use.
VGA Connector:	To connect with PC monitor.
Speaker Out:	To External Speaker, Earphone or Amplifier.
Line-In:	Comes from the signal sources, such as CD/Tape player.
MIC-In:	From Microphone.



## USB2.0 Connector

This model provides six USB2.0 ports to connect USB devices such as mouse, keyboard, modem, printer, etc. There are four connectors on the back panel. You can use proper cables to connect USB devices from the back panel or connect USB header to the front panel of chassis.

Compared to traditional USB 1.0/1.1 with the speed of 12Mbps, USB 2.0 has a fancy speed up to 480Mbps which is 40 times faster than the traditional one. Except for the speed increase, USB 2.0 supports old USB 1.0/1.1 software and peripherals, offering impressive and even better compatibility to customers. On this motherboard, all six ports support USB 2.0 function.

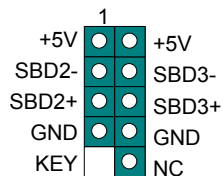

Pin 1

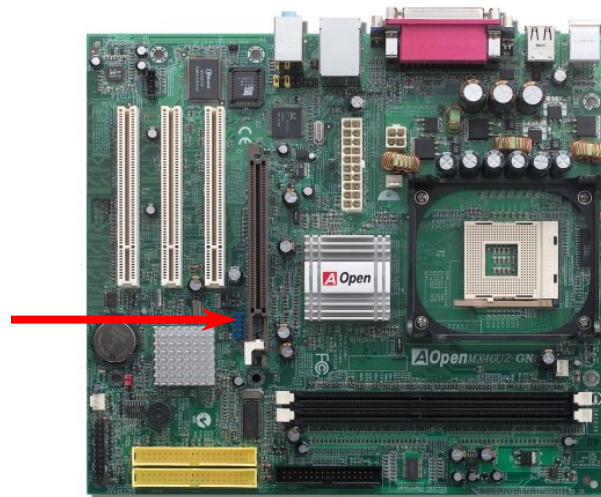

## Case Open Connector

The “CASE OPEN” header provides chassis intrusion-monitoring function. To make this function works, you have to enable it in the system BIOS, connect this header to a sensor somewhere on the chassis. So, whenever the sensor is triggered by lights or by the opening of the chassis, the system will beep to inform you. Please be informed that this useful function only applies to advanced chassis, you may purchase an extra sensor, attach it on your chassis, and make a good use of this function.

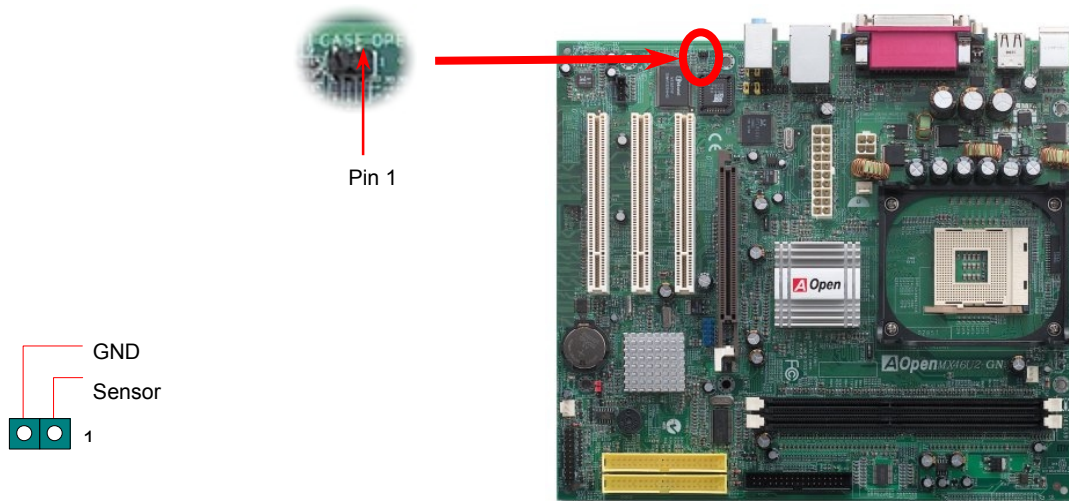

## CD Audio Connector

This connector is used to connect CD Audio cable from CDROM or DVD drive to onboard sound.

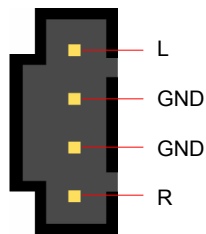

CD-IN Connector

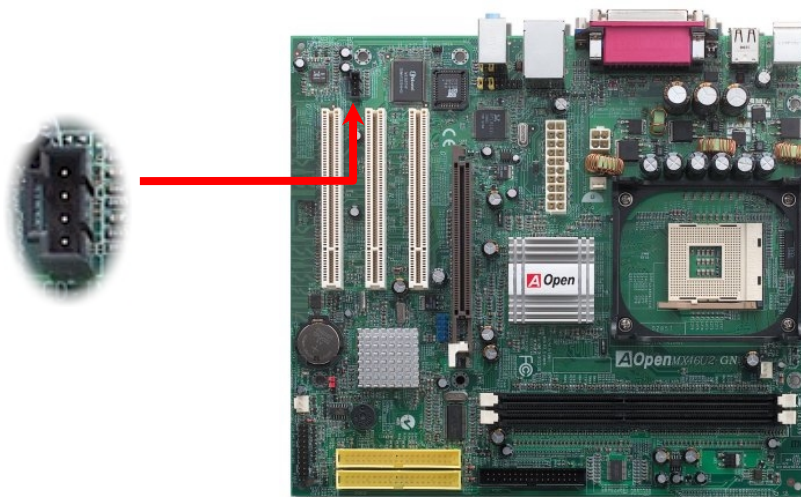



## Front Audio Connector

If the housing has been designed with an audio port on the front panel, you'll be able to connect onboard audio to front panel through this connector. By the way, please remove the jumper cap from the Front Audio Connector before you connect the cable. Do not remove this yellow jumper cap if your housing doesn't have an audio port on the front panel.

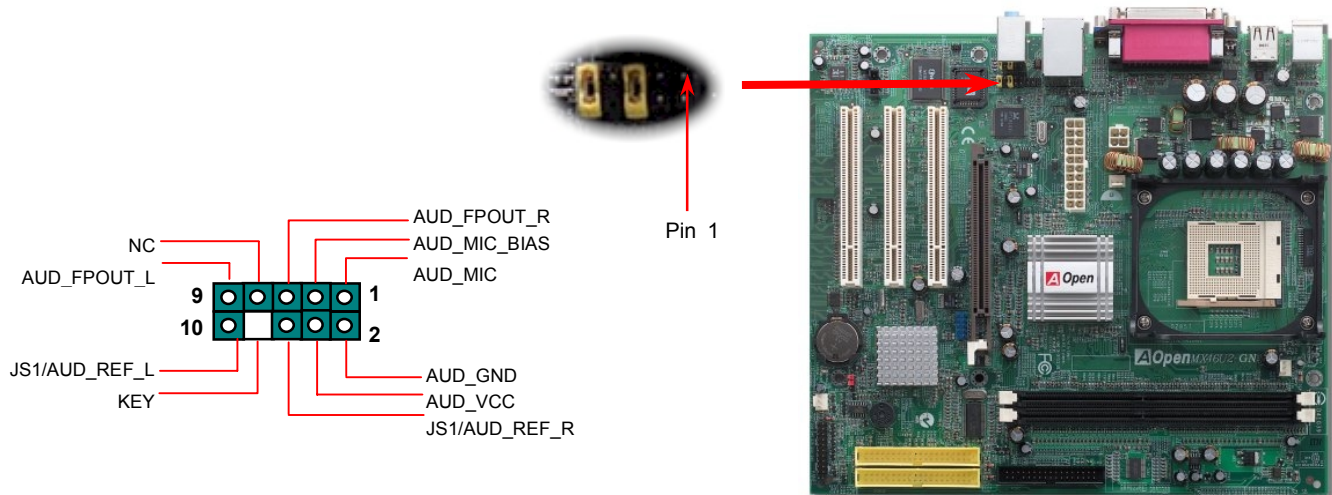

**Note:** Please remove the jumper cap from the front audio connector before you connect the cable. Do not remove this yellow jumper cap if your housing doesn't have an audio port on the front panel.



## JP14 Clear CMOS Data

You can clear CMOS to restore system default setting. To clear CMOS, follow the procedure below.

1. Turn off the system and unplug the AC power.
2. Remove ATX power cable from connector PWR2.
3. Locate JP14 and short pins 2-3 for a few seconds.
4. Return JP14 to its normal setting by shorting pin 1 & pin 2.
5. Connect ATX power cable back to connector PWR2.

Pin 1

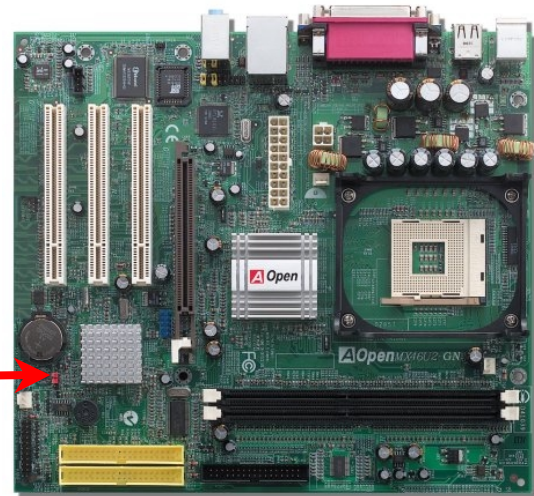

Normal  
(default)



Clear CMOS

### **Tip:** When should I Clear CMOS?

1. Boot fail because of overclocking...
2. Forget password...
3. Troubleshooting...

## STBY LED

STBY LED is AOpen's considerate design that we aim at providing you friendly system information. The STBY LED will light up when power is provided to the motherboard. This is a convenient indication for you to check the system power status in many circumstances such as power on/off, stand-by mode and RAM power status during Suspend to RAM mode.

Standby  
Power LED

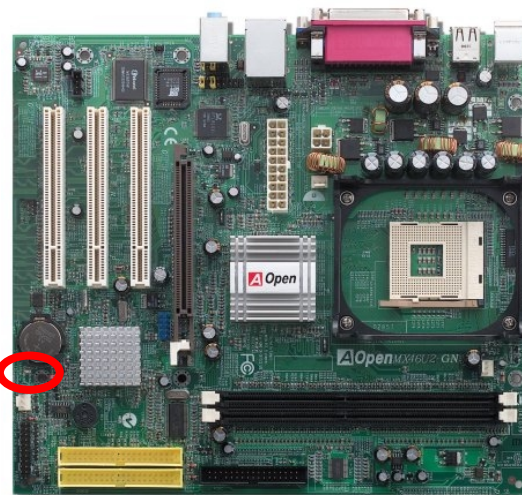
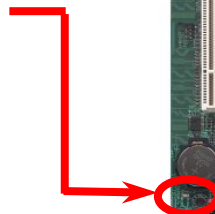

**Warning:** Do not install or remove the DIMM module or others devices when the STBY LED lights on.

## AOpen “Watch Dog Timer”



AOpen provides a special and useful feature on this motherboard for overclockers. When you power-on the system, the BIOS will check last system [POST](#) status. If it succeeded, the BIOS will enable “Watch Dog Timer” function immediately, and set the CPU [FSB](#) frequency according to user’s settings stored in the BIOS. If system failed in BIOS POST, the “Watch Dog Timer” will reset the system to reboot in five seconds. Then, BIOS will detect the CPU’s default frequency and POST again. With this special feature, you can

easily overclock your system to get a higher system performance without removing the system housing and save the hassle from setting the jumper to clear CMOS data when system hangs.

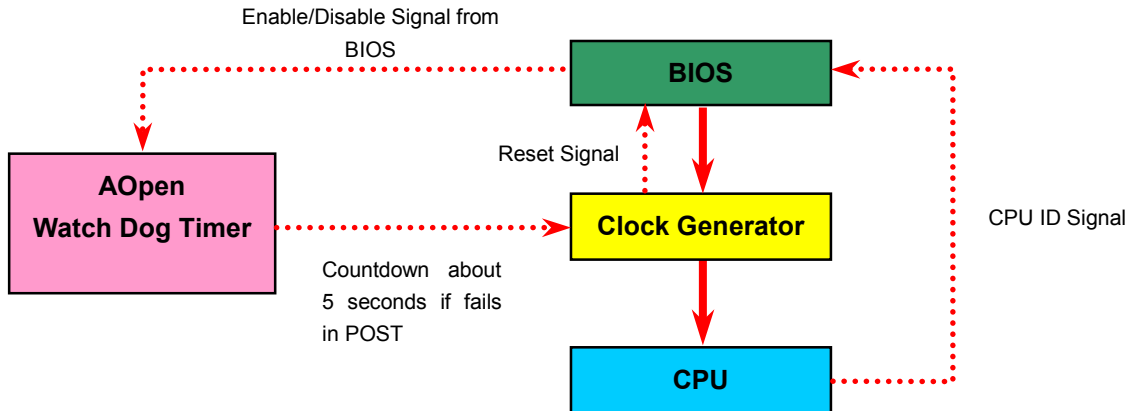

## Battery-less and Long Life Design

This Motherboard implements a [Flash ROM](#) and a special circuit that provide you no batter power consumption of current CPU and CMOS Setup configurations. The RTC (real time clock) can also keep running as long as the power cord is plugged. If you lose your CMOS data by accident, you can just reload the CMOS configurations from Flash ROM and the system will recover as usual.

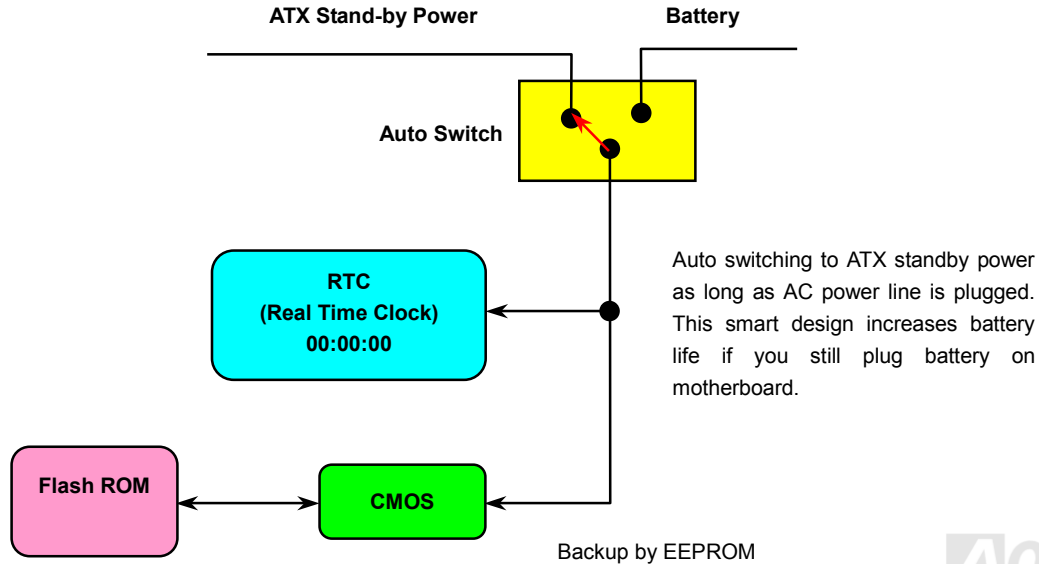

## Over-current Protection

The Over Current Protection is a popular implementation on ATX 3.3V/5V/12V switching power supply. However, the new generation CPU uses different voltage with a regulator to transfer 12V to CPU voltage (for example, 2.0V), and thus makes 5V over current protection useless. This motherboard is with switching regulator onboard supporting CPU over-current protection; in conjunction with 3.3V/5V/12V power supply provide the full line over-current protection.

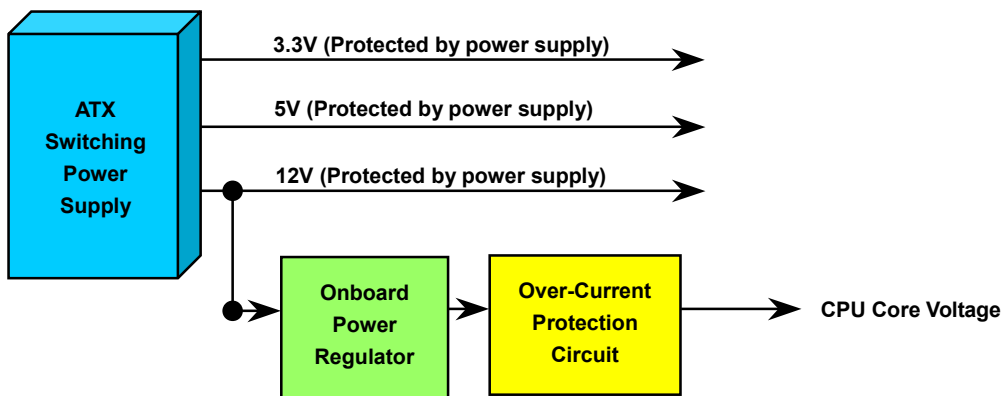

**Note:** Although we have implemented protection circuit and tried to prevent any human operating mistake, certain risks might still happen when CPU, memory, HDD or add-on cards installed on this motherboard is damaged due to component failure, human operating error or other unknown natural reasons. **AOpen cannot guarantee that the protection circuit will always work perfectly.**

## Resettable Fuse

Traditional motherboard uses fuses to prevent Keyboard and [USB](#) port from over-current or shortage. These fuses are soldered onboard that when it is broken (function to protect motherboard), user cannot replace them and result in malfunction of motherboard.

With expensive Resettable Fuse, the motherboard can be resumed back to normal function even after the fuse had done its protection job.

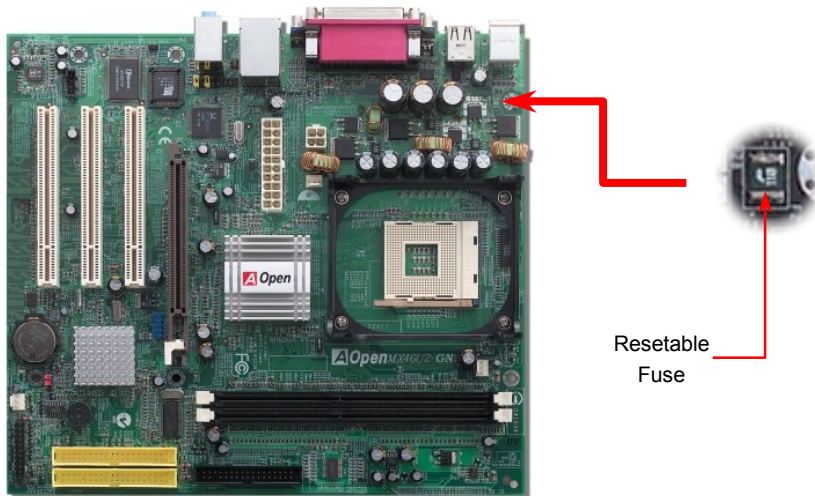

## Low ESR Capacitor

The quality of low ESR capacitor (Low Equivalent Series Resistance) during high frequency operation is very important for the stability of CPU power. The idea of where to put these capacitors is another know-how that requires experience and detail calculation.

Not only that, MX46U2-GN / MX46-533GN implements 3300  $\mu F$  capacitors, which is much larger than normal capacitor (1000 & 1500  $\mu F$ ) and it provides better stability for CPU power.

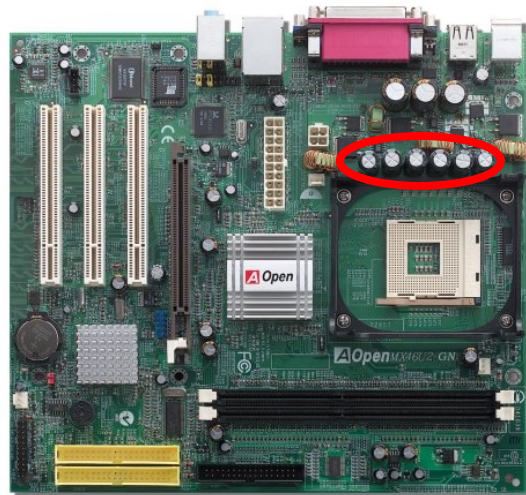



The power circuit of the CPU core voltage must be checked to ensure system stability for high speed CPUs (such as the new Pentium III, or when overclocking). A typical CPU core voltage is 2.0V, so a good design should control voltage between 1.860V and 2.140V. That is, the transient must be below 280mV. Below is a timing diagram captured by a Digital Storage Scope, it shows the voltage transient is only 143mv even when maximum 60A current is applied.

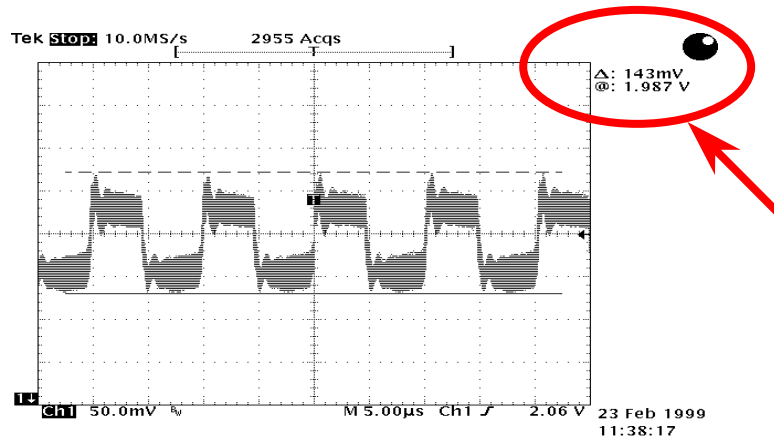

Note: This diagram for example only, it may not be exactly the same as the motherboard you purchased.

# Phoenix Award BIOS

System parameters can be modified by going into [BIOS](#) Setup menu, this menu allows you to configure the system parameters and save the configuration into the 128 bytes CMOS area, (normally in the RTC chip or in the main chipset).

The Phoenix AwardBIOS™ that installed in the [Flash ROM](#) of the motherboard is a custom version of an industry standard BIOS. The BIOS provides critical low-level support for standard devices such as hard disk drives, serial and parallel ports.

Most BIOS setting of this model had been optimized by AOpen's R&D engineering team. But, the default setting of BIOS still can't fine-tune the chipset controlling the entire system. Hence, the rest of this chapter is intended to guide you through the process of configuring your system using setup procedures.

[To enter to BIOS setup menu](#), press <Del> when [POST \(Power-On Self Test\)](#) screen is shown on your monitor.

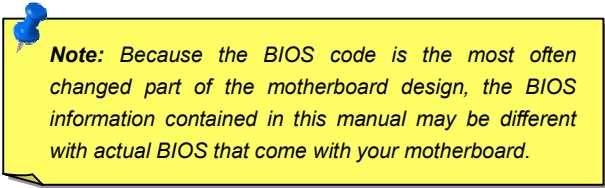

***Note:** Because the BIOS code is the most often changed part of the motherboard design, the BIOS information contained in this manual may be different with actual BIOS that come with your motherboard.*

## About BIOS Function Description...

AOpen always dedicates to give user a more friendly computer system. Now, we include all function descriptions of BIOS setup program into the BIOS Flash ROM. When you select one function of BIOS setup program, the function description will appear at the right side of screen. Therefore, you don't need to read this manual while you change BIOS settings.

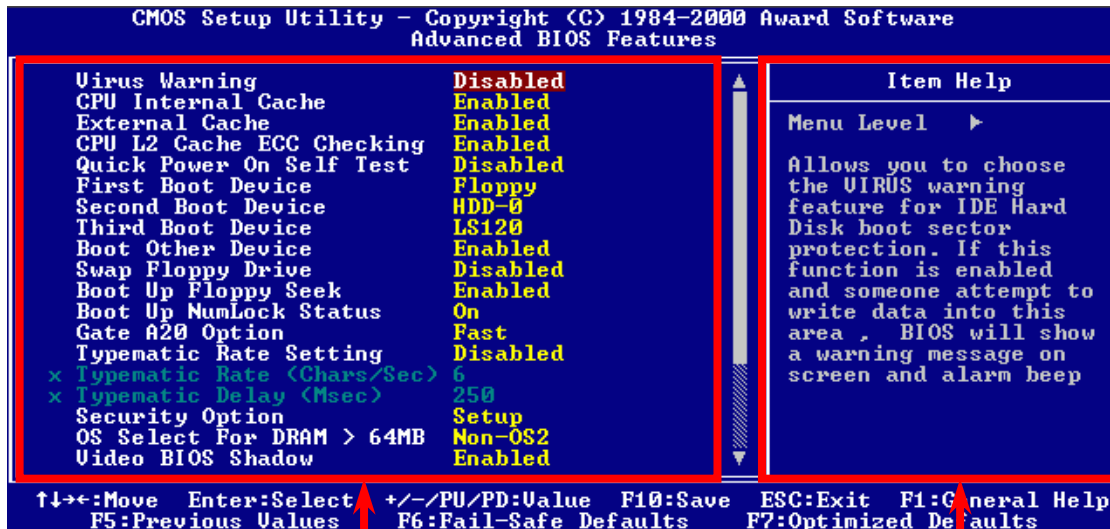

Menu Items Select Window

Item Function Description Window



## How To Use Phoenix Award™ BIOS Setup Program

Generally, you can use the arrow keys to highlight items that you want to choose, then press <Enter> key to select, and use the <Page Up> and <Page Down> key to change setting value. You also can press <F1> key for help and press <Esc> key to quit Phoenix Award™ BIOS setup program. The following table provides details about how to use keyboard in the Phoenix Award™ BIOS setup program. By the way, all products of AOpen also provides a special function in the BIOS setup, you can press <F3> key selecting preferred menu language to display.

Key	Description
Page Up or +	Changing setting to next value or increase the value.
Page Down or -	Changing setting to previous value or decrease value.
Enter	Select the item.
Esc	1. In main menu: Quit and don't save any change. 2. In sub menu: Exit current menu to main menu.
Up Arrow	Highlight previous item.
Down Arrow	Highlight next item.
Left Arrow	Move the light bar to left side of menu.
Right Arrow	Move the light bar to right side of menu.
F1	Get menu or item help description.
F3	Changing menu language.
F5	Load previous setting value from CMOS.

<b>Key</b>	<b>Description</b>
F6	Load fail-save setting value from CMOS.
F7	Load turbo setting value from CMOS.
F10	Save changed setting and exit setup program.

## How To Enter BIOS Setup

After you finish jumper settings and connect correct cables, power on and enter the BIOS Setup. Press <Del> during [POST \(Power-On Self Test\)](#) and choose "Load Setup Defaults" for recommended optimal performance.

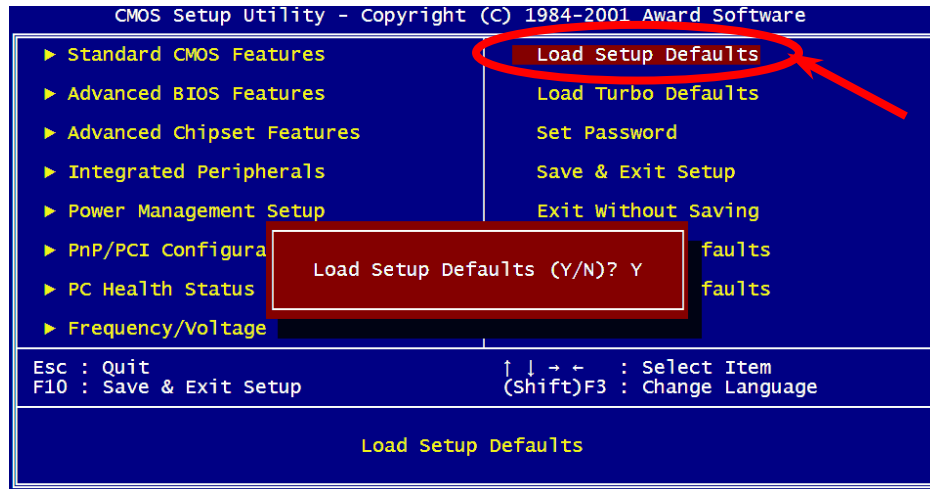

**Warning:** Please avoid of using "Load Turbo Defaults", unless you are sure your system components (CPU, DRAM, HDD, etc.) are good enough for turbo setting.

## BIOS Upgrade under Windows environment



With outstanding R&D ability of AOpen, we now bring you a whole new BIOS Flash wizard --- EzWinFlash. With an eye to users convenience, EzWinFlash combines the BIOS binary code and flash module together, so the only thing you have to do is just clicking on the utility you downloaded from web and let it helps you complete the flash process automatically. EzWinFlash detects your motherboard and checks the BIOS version cleverly to prevent your system from any possible failure. Moreover, EzWinFlash has been taken into consideration to go with any windows platform you might be using, no matter if you're using Windows 95/98, 98SE/ME, NT4.0/2000, or even the latest Windows XP.

In the meanwhile, in order to provide a much more user-friendly operating environment, AOpen EzWinFlash is natively designed to have multi-language function to provide easier way for users' usage in changing BIOS setting.

EzWinFlash V1.0.0 - 28 Nov, 2001, 16:54:25

Flash ROM Information		CheckSum : F1A9H Option	Start Flash
Flash Type	Intel E82802AB /3.3V [4Mb]		
Current BIOS Information		<input type="checkbox"/> Clear PnP Area <input type="checkbox"/> Clear DMI Area <input checked="" type="checkbox"/> Clear CMOS	Save BIOS
Model Name	AX3SPlus		
BIOS Version	R1.09	Language	About
Release Date	Oct.09.2001		
New BIOS Information		<input checked="" type="radio"/> English <input type="radio"/> German <input type="radio"/> Chinese-BIG5	Exit
Model Name	AX3SPlus		
BIOS Version	R1.09	Message	
Release Date	Oct.09.2001	If you are sure to program new BIOS, please press [Start Flash] button.	

**Caution:** By updating your motherboard, you are taking a risk of BIOS flash failure. If your motherboard is working stable, and there are no major bugs that had been fixed by a latter BIOS revision, we recommend that you DO NOT try to upgrade your BIOS.

If you intent on upgrading, PLEASE BE SURE to get the right BIOS revision for the right motherboard model to avoid any possibility failure.

You may accomplish BIOS upgrade procedure with EzWinFlash by the following steps, and it's STRONGLY RECOMMENDED to close all the applications before you start the upgrading.

1. Download the new version of BIOS package [zip](http://www.aopen.com) file from AOpen official web site. (ex: <http://www.aopen.com>)
2. Unzip the download BIOS package (ex: WMX46U2GN102.ZIP) with WinZip (<http://www.winzip.com>) in Windows environment.
3. Save the unzipped files into a folder, for example, WMX46U2GN102.EXE & WMX46U2GN102.BIN.
4. Double click on the WMX46U2GN102.EXE, EzWinFlash will detect the model name and BIOS version of your motherboard. If you had got the wrong BIOS, you will not be allowed to proceed with the flash steps.
5. You may select preferred language in the main menu, then click [Start Flash] to start the BIOS upgrade procedure.
6. EzWinFlash will complete all the process automatically, and a dialogue box will pop up to ask you to restart Windows. You may click [YES] to reboot Windows.
7. Press <Del> at POST to [enter BIOS setup](#), choose "Load Setup Defaults", then "Save & Exit Setup". Done!

**It is strongly recommended NOT to turn off the power or run any application during FLASH PROCESS.**



**Warning:** *The new BIOS upgrade will permanently replace your original BIOS's settings when flashing. You may need to reconfigure your BIOS setting so that your system can go back to work as normal.*



## Vivid BIOS technology

**NEW!**

Have you been fed up with the conservative and immutable POST screen? Let's rule out the tradition idea that POST screen are stiff and frigid, and let AOpen show you the newly developed VividBIOS to experience the lively vivid colorful POST screen!

Unlike earlier graphic POST screen which could occupy the whole screen and mask text information during POST, AOpen VividBIOS deals with graphics and texts separately, and makes them running simultaneously during POST. With this innovative design, VividBios now brings you a beautiful and sleek 256 colors screen without missing any important information shown on POST screen.

In addition, the limited space of BIOS ROM is another big issue. When all of the traditional BIOS can only show space-consuming and uncompressed Bitmap, AOpen has considerably tuned the BIOS to next generation, to recognize the smaller-sized GIF format and even dynamic-showing GIF animation.



Vivid BIOS shares the same fundamental technology with Open JukeBox CD Player, you may use the same EzSkin utility to

change your Vivid BIOS screen or to download your favorite Open JukeBox skin. If you see this little logo  shown beside your model name on the BIOS download page, <http://english.aopen.com.tw/tech/download/skin>, it is assured that your motherboard supports this innovative feature!



## The noise is gone!! ---- SilentTek



As the clock of CPU keeps rocketing higher and higher, it inevitably brings higher heat and system temperature in a relative way. The way we deal with this heat problem, however, is to spare no effort to add one fan after another to protect our pampered system, expecting these fans could cool down our machine as much as they could.

But at the same time, we believe that same users are affected terribly by the irritating noises of these fans while working with their PC. As a matter of fact, we do not have to get our fans running at such a high speed in most cases; on the contrary, we discovered

Phoenix - AwardBIOS CMOS Setup Utility  
Silent PC/PC Health Status

CPU Warning Temp.	60° C/140° F	
CPUFan1 Boot Speed	70% 3150 RPM	
SYSFan2 Boot Speed	70% 3500 RPM	
CPUFan1 OS Speed	100% 4500 RPM	
SYSFan2 OS Speed	100% 5000 RPM	
Fan Mode	Smart Control	
x CPUFan1 Fixed Speed	100% 4500 RPM	
x SYSFan2 Fixed Speed	100% 5000 RPM	
CPU Set Temp.	40° C	
SYS Set Temp.	30° C	
CPU Kernel Temp.	69° C/156° F	
CPU Temp.	47° C/116° F	
SYS Temp.	31° C/107° F	
CPUFAN1 Speed	4500 RPM	
SYSFAN2 Speed	5000 RPM	
SYSFAN3 Speed	5532 RPM	
Vcore(V)	1.48 V	

Item Help

Menu Level ▶

This is fan control mode during POST and Open Jukebox, after exiting the Jukebox, the fan will be set to Fan OS Speed.

[Full Speed] Run in full speed.

[Smart Control] According to the safety temperature you set below, fan speed will be controlled as slow as possible.

↑↓←→:Move Enter:Select +/-/PU/PD:Value F10:Save ESC:Exit F1:General Help  
F2:Item Help F5:Previous Values F6:Setup Defaults F7:Turbo Defaults

that having your fans running at appropriate time and speed not only reduces the noise, but also consumes the least power the system needs, so as to prevent over-wasting of energy resource.

Today, AOpen Motherboard is honored to bring you a new overall solution, SilentTek, to make your system quiet. To collocate with hardware circuit, BIOS and the utility under Windows, SilentTek combined "Hardware-Status Monitoring", "Overheat Warning" and "Fan Speed Control" with user-friendly interfaces to provide you a perfect balance among noises, system performance and stability.



The first image you have here is the Voltage Status page. You can find current status of all voltages and set your expected margins of warning level.

In “Temp/Fan/Case” page, you may get aware of the current temperature of CPU and the heat inside chassis. Also, you can check if fans are running properly.

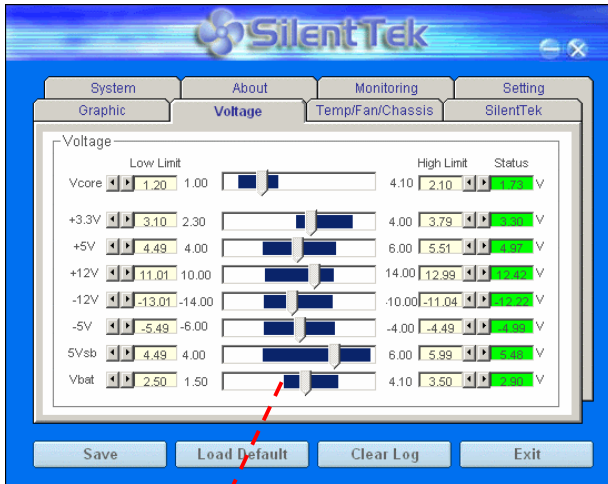

You may check your system voltage from the indicating bar here.

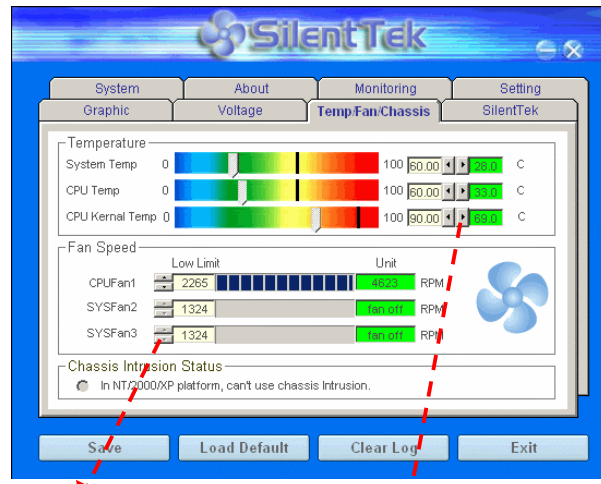

Of course, you may set your defaulted lowest margin for your fans and SilentTek would also pop up a message box to alarm you when the fan is rotating slower than this specified speed.

You may set the highest margin of your CPU and system temperature as default, and SilentTek would pop up a message box to alert you with alarm when the temperature goes beyond the specified margin.



The following page is surely the most important part of this utility. You may control the rotation speed of specific fans that you have got the options inside in this page.

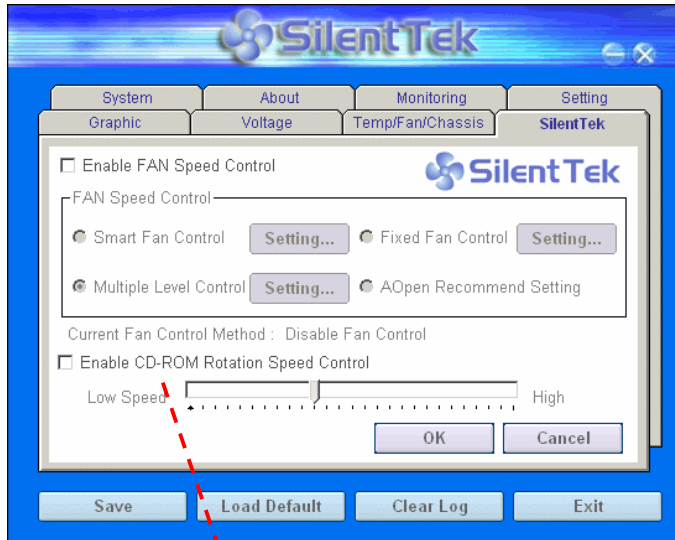

**CD-ROM Rotation Speed Control:** by enabling the CD-ROM Rotation Speed Control, you can adjust the rotation speed of your CD-ROM. When you set the speed to high level, the CD-ROM will work at its fastest speed and it will run at basic required speed while you set the value to low speed.

1. **Smart FAN Control:** This is the default setting of SilentTek and can be used for any branded computer housing. With a special algorithm developed by AOpen, the fan speed is automatically adjusted by the factors of CPU and ambient temperature. Ease-of-use and trouble free at your service.
2. **Fixed FAN Control:** Under this setting, a desired fan speed is set fixed when operating.
3. **Multiple Level Control:** This is the most versatile setting that allows you to set fan speed in relation to temperature. You may find that this setting fits you best.
4. **AOpen Recommend Setting:** This setting is designed specifically for AOpen housing. A series of lab tests were conducted under the real world scenario to determine optimum fan speed to reduce noise level within CPU working condition and temperature. Most of the time, the fan would remain still when CPU is not fully utilized.

**Note:** Due to hundreds different brands of fan on the market, inaccuracy may happen in some cases when you had your rotation speed adjusted. It is still under the criterion and please rest assured that it won't cause any problem to your system.

# Driver and Utility

There are motherboard drivers and utilities in [AOpen Bonus CD](#). You don't need to install all of them to boot your system. But after you finish the hardware installation, you have to install your operation system first (such as Windows 98) before you install any drivers or utilities. Please refer to your operation system's installation guide.

## Auto-run Menu from Bonus CD

You can use the auto-run menu of Bonus CD. Choose the utility and driver and select model name.

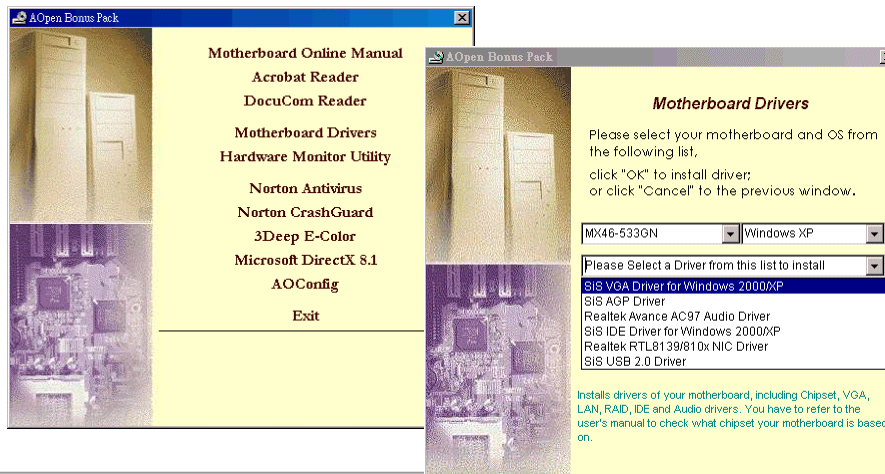

## Installing IDE Driver

To use IDE devices you have to install IDE driver from Bonus Pack CD.

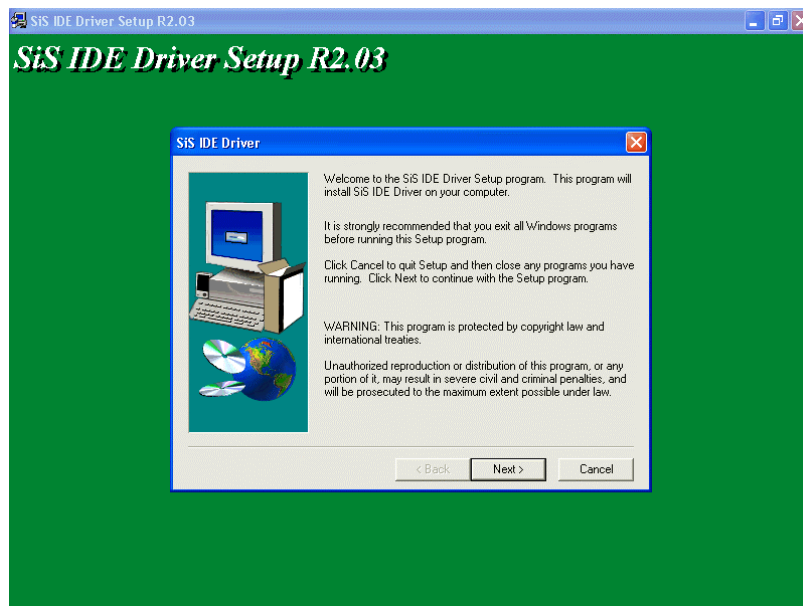

## **Installing AGP Driver**

You can find AGP driver from the Bonus Pack CD auto-run menu.

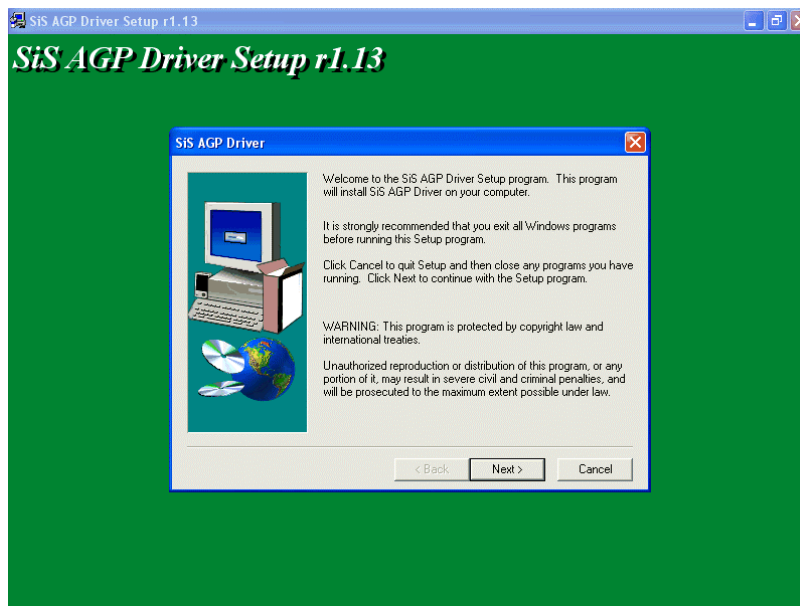

## Installing VGA Driver

SiS 650GX supports VGA on this motherboard. You can install VGA driver form the Bonus Pack CD.

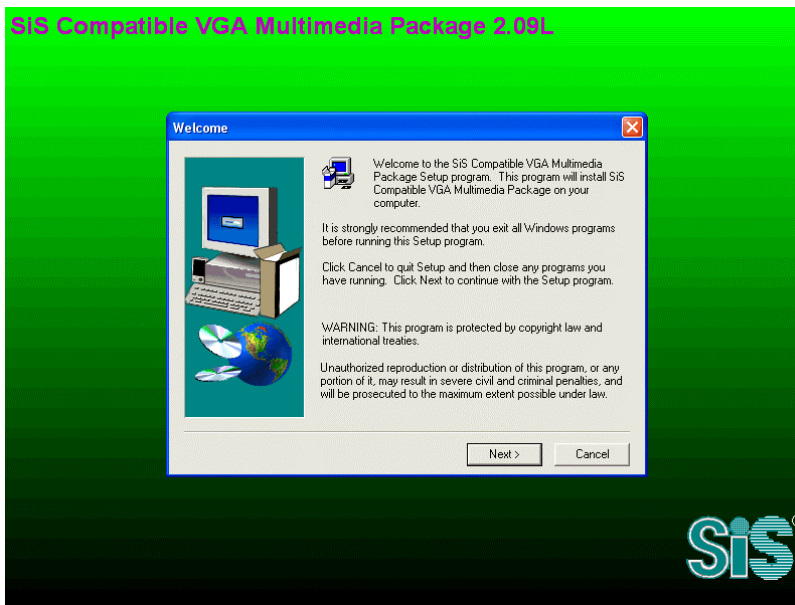



## **Installing USB2.0 Driver**

In Bonus Pack CD, you can install USB2.0 driver from the following screen.



## **Installing Audio Driver**

In Bonus Pack CD, you can install audio driver from the following screen.

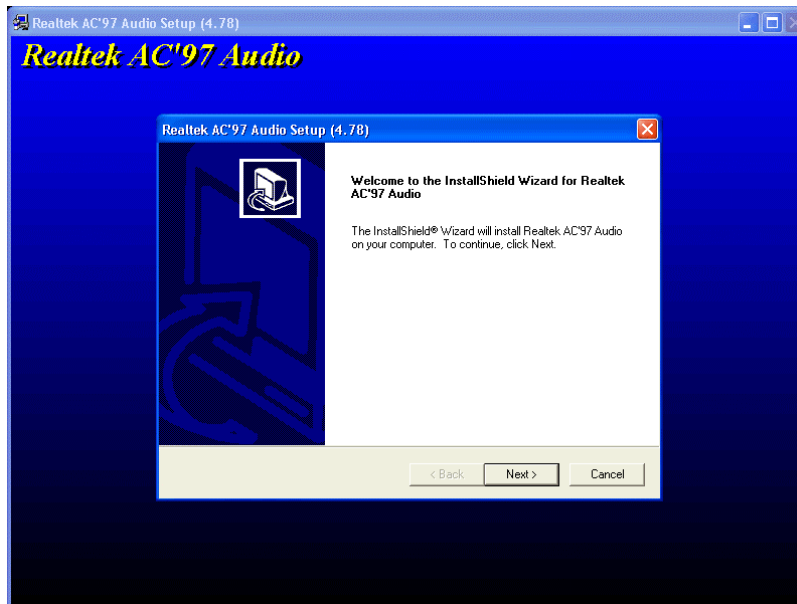

## Installing LAN Driver

Introduction:

-----  
This document describes the procedure to install Windows 95 (Golden version), Win95A, OSR2, Windows NT v4.0 drivers for Realtek RTL8139 PCI Fast Ethernet adapter.

[Windows 95 (Golden version), Win95A and OSR2]

Installing driver procedure on Microsoft Windows 95 :

- 
1. Ask you to select which driver you want to install, select "Driver from disk provided by hardware manufacturer".
  2. Specify the setup file pathname  
[CD-ROM]:\Driver\LAN\RTL8100\Windows\95\WIN95A (for Windows 95 and Win95A) or  
[CD-ROM]:\Driver\LAN\RTL8100\Windows\95\W95OSR2 (for Windows 95 OSR2).
  3. Windows 95 will appear some messages to insert Windows 95 system disk to complete setup step.
  4. Windows 95 will finish the other installation procedure automatically, then you restart the system.

[Windows NT 3.5, 3.51 & 4.0]

Installing driver procedure on Microsoft Windows NT :

-----  
When you are in Windows NT :

1. In the Main group of NT, select the "Control Panel" icon.
2. In the Control Panel window, choose the "Network" icon.
3. In the Network Settings dialog box, choose the "Add Adapter" button. The Add Network Adapter dialog box appears.
4. In the list of network cards, select "<other> Requires disk from manufacturer", and then press <Enter> button.

5. Enter drive and pathname

[CD-ROM]:\Driver\LAN\RTL8100\Windows\NT (for NT 4.0) which is the path where the setup file OEMSETUP.INF is located, and then choose the OK button.

6. The screen will appear "Select Line Speed" dialog box which is provide by RTL8139.SYS driver. The default value is "auto" so that the RTL8139 PCI Fast Ethernet adapter and its driver RTL8139.SYS will auto-detect the line speed, 10Mb or 100Mb, while the RTL8139.SYS is loading. The other values, "10" or "100", are only used when you want to forced RTL8139 PCI Fast Ethernet adapter to 10Mb or 100Mb.
7. The screen will appear "Input EthernetID" dialog box which is provided by RTL8139.SYS driver. This option is only required when you have more than one Realtek RTL8139 PCI Fast Ethernet adapters on this computer. Select "SKIP" if only one adapter is installed on this computer.
8. "Bus Location" display in next screen. Your machine contains more than one hardware bus, please select the Bus Type and Bus number on which your network adapter card is installed.
9. NT will then perform the binding process. If any additional network software options were installed, you may be prompted for specific information for these packages.
10. Restarting your system you will acquire network service.

NOTES:

-----

\* Installing Multiple LAN Adapters:

Enter Windows NT and follow above setup procedure step 2, in the "Network Settings" dialog box, choose the "Configure.." button. The "Input Ethernet ID" dialog box appears and input adapter's Ethernet ID. Last step to select OK and close NETWORK SETUP. Select SKIP if only one adapter is installed on this computer.

[Windows 98, 98SE, ME, 2000 and XP]

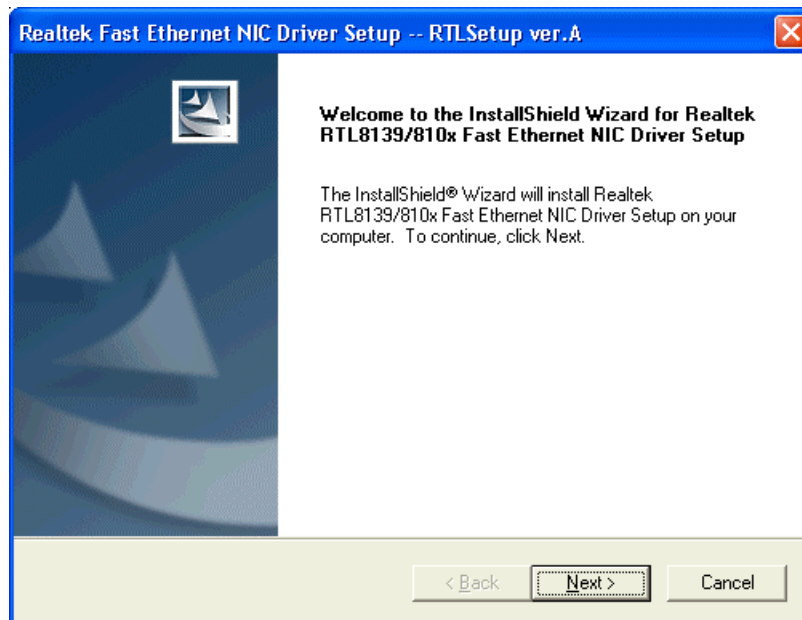

## AOConfig Utility



AOpen always dedicated to provide users a much friendly computer environment. We now bring you a comprehensive system detection utility. AOConfig is a Windows based utility with user-friendly interface that allows users to obtain information of the operation system and hardware such as motherboard, CPU, memory, PCI devices and IDE devices. The powerful utility also displays the version of BIOS and firmware for your convenience of maintenance.

CPU, memory, PCI devices and IDE devices. The powerful utility also displays the version of BIOS and firmware for your convenience of maintenance.

Moreover, AOConfig allows users to save information in \*.BMP or \*.TXT format which users may collect the system information in detail and send them to AOpen directly for technical support or for further diagnose of system problems.

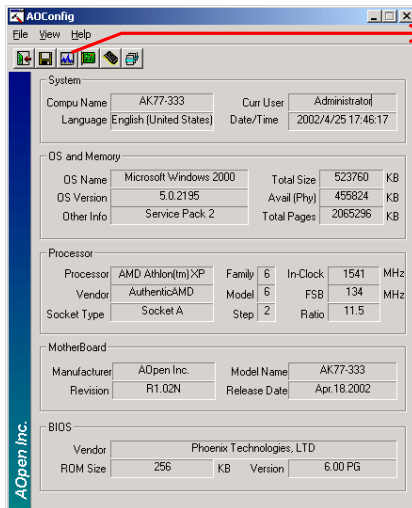

1. The system page shows the detail information of the motherboard, the operating system, the processor, and BIOS version.

2. The PCI device page shows the configurations of all PCI devices installed on your motherboard.

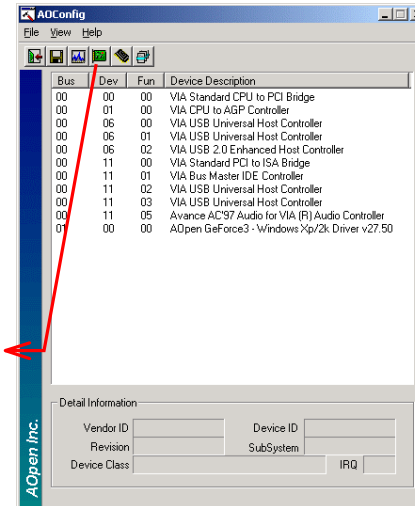

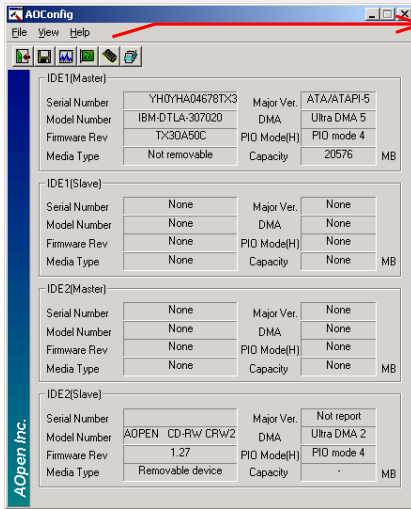

3. This page presents the IDE devices information, such as the serial number, the manufacturer, the firmware version, and capacity.

4. From this page, users may obtain the technical support information of AOpen. Moreover, detailed information could be saved in .bmp or .txt format.

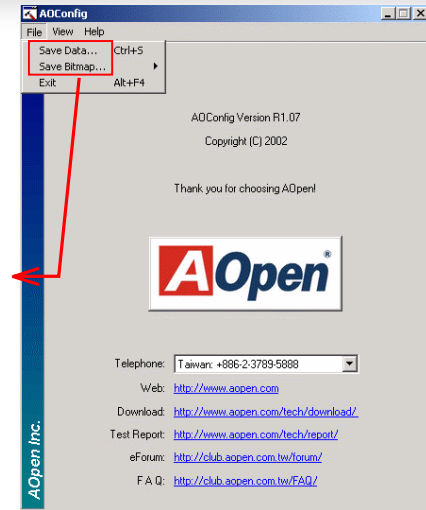

**NOTE:** AOconfig can be used in Windows 98SE/ME, NT4.0/2000, or even the latest Windows XP. Please be informed that AOconfig can only be operated in a system equipped with an AOpen motherboard. Meanwhile, all applications must be closed before starting AOconfig.

# Glossary

## **AC97 CODEC**

Basically, AC97 CODEC is the standard structure of PCI sound card. As we know, computer is digital-based, but music is based on analog-based. Therefore, there must be a process to turn digital into analog during the last stage processing of sound in computer. Hence, the component on sound card that play this important task is what we called CODEC.

Audio CODEC 97 (briefly called AC97) is the specification regulated by Intel, and it's about the structure of audio conversion. The special place about CODEC is that it is separated from sound card (CODEC is an independent chipset). Therefore, PCI sound card could possess with 90db and do other application process as well. We called CODEC that meets this structure AC97 CODEC.

## **ACPI (Advanced Configuration & Power Interface)**

ACPI is the power management specification of PC97 (1997). It intends to save more power by taking full control of power management to operating system and bypass [BIOS](#). The chipset or super I/O chip needs to provide standard register interface to operating system (such as Windows 98). This is a bit similar as the [PnP](#) register interface. ACPI defines ATX momentary soft power switch to control the power state transition.

## **ACR (Advanced Communication Riser)**

Building on the PC motherboard riser architecture, ACR slot is backward compatible with AMR but beyond the limitation of it. The ACR specification is designed to support modem, audio, Local Area Network (LAN) and Digital Subscriber Line (DSL).



### **AGP (Accelerated Graphic Port)**

The main function of AGP simply put is to tell monitor what screen information had to be shown, a visual transmission device actually. With the rapid developing of AGP card, we can see that it had been developed from single colorful AGP card to 2D and 3D graphic. AGP supports only memory read/write operation and single-master single-slave one-to-one only. Though AGP and PCI share the same algorithm of 32-bit, its frequencies are 66MHz and 33MHz respectively. AGP interface had been developed from 2X to 8x.

**1X AGP**, data transfer rate is  $66\text{MHz} \times 4\text{byte} \times 1 = 264\text{MB/s}$

**2X AGP**, data transfer rate is  $66\text{MHz} \times 4\text{byte} \times 2 = 528\text{MB/s}$

**4X AGP**, data transfer rate is  $66\text{MHz} \times 4\text{byte} \times 4 = 1056\text{MB/s}$ .

**8X AGP**, data transfer rate is  $66\text{MHz} \times 4\text{byte} \times 8 = 2112\text{MB/s}$ .

### **AMR (Audio/Modem Riser)**

The CODEC circuit of AC97 sound/modem solution can be put on motherboard or put on a riser card (AMR card) that connects to motherboard through AMR connector.

### **ATA (AT Attachment)**

Before talking about ATA (AT Attachment), we must understand **DMA** (Direct Memory Access), which allows devices to skip the CPU devices and access memory directly. DMA specification could not only eliminate the workload of CPU, but also accelerate the transmission of data. DMA begins with a data transfer rate of 16.6MB/Sec, but afterward developed to new data rate of 33.3MB/Sec, which is twice the data rate and we called it **Ultra DMA**. **ATA** details power and data signals between the drive and integrated

drive controller and the computer's motherboard. Two drives (master and slave) are supported. The ATA specification allows the drive to connect directly to the ISA bus on the computer. ATA transfer rate then had been developed to 133MB /Sec and would come out with fastest rate later (please refer to [Serial ATA](#)).

**DMA**, data transfer rate is 16.6MB/s.

**Ultra DMA**, data transfer rate is  $16.6\text{MHz} \times 2 = 33\text{MB/s}$ .

**ATA/66**, data transfer rate is  $16.6\text{MHz} \times 4 = 66\text{MB/s}$ .

**ATA/100**, data transfer rate is  $16.6\text{MHz} \times 6 = 100\text{MB/s}$ .

**ATA/133**, data transfer rate is  $16.6\text{MHz} \times 8 = 133\text{MB/s}$ .

(ATA/133 uses both rising edge and falling edge as ATA/66 but clock cycle time is reduced to 30ns.)

### **BIOS (Basic Input/Output System)**

BIOS, is a set of assembly routine/program that reside in [EPROM](#) or [Flash ROM](#). BIOS controls Input/output devices and other hardware devices of motherboard. In general, to provide hardware independent portability, operation system and drivers is required to access BIOS without directly access hardware devices.

### **Bluetooth**

Bluetooth is a wireless transferring technology that enables short-range wireless connections between desktop and laptop computers, personal digital assistants (PDAs), cellular phones, printers, scanners, digital cameras and even home appliances. The principle of Bluetooth (a chipset) is to transfer information and voices at the frequency of ISM Band. Every Bluetooth technology devices do come with a standard address for you to connect one-to-one or one-to-seven (to form a Pico-net), with transferring range up to 10 meters (100 meters to follow), using low power radio. Bluetooth do not only possess high transfer rate of 1MB/s, it

also could be encrypted with pin code. With hopping rate of 1600 hops per second, it's difficult to be intercepted and are less interrupted by electromagnetic wave.

### **CNR (Communication and Networking Riser)**

The CNR specification provides the PC industry the opportunity to deliver a flexible and cost reduced method of implementing LAN, home networking, DSL, USB, wireless, audio and modem subsystems widely used in today's "connected PCs". The CNR specification is an open industry specification and is supported by OEMs, IHV card manufacturers, silicon supplier and Microsoft.

### **DDR (Double Data Rate) RAM**

DDR RAM utilizes the existing [SDRAM](#) (For ex, PC-100, PC-133) infrastructure and technology while doubling the nominal bandwidth available to systems in an easy to design and simple to adopt way. Based on FSB frequency, DDR RAM on the market are DDR200, DDR266 and DDR333 with more coming around soon.

**DDR200**, transfer bandwidth up to  $200 \times 64 / 8 = 1600 \text{MB/s}$  (PC1600)

**DDR266**, transfer bandwidth up to  $266 \times 64 / 8 = 2100 \text{MB/s}$  (PC2100)

**DDR333**, transfer bandwidth up to  $333 \times 64 / 8 = 2700 \text{MB/s}$  (PC2700)

**DDR400**, transfer bandwidth up to  $400 \times 64 / 8 = 3200 \text{MB/s}$  (PC3200)

### **ECC (Error Checking and Correction)**

The ECC mode needs 8 ECC bits for 64-bit data. Each time memory is accessed; ECC bits are updated and checked by a special

algorithm. The ECC algorithm has the ability to detect double-bit error and automatically correct single-bit error while parity mode can only detect single-bit error.

### **EEPROM (Electronic Erasable Programmable ROM)**

Also known as E<sup>2</sup>PROM. Both EEPROM and [Flash ROM](#) can be re-programmed by electronic signals, but the interface technology is different. Size of EEPROM is much smaller than flash ROM.

### **EPROM (Erasable Programmable ROM)**

Traditional motherboard stores BIOS code in EPROM. EPROM can only be erased by ultra-violet (UV) light. If BIOS has to be upgraded, you need to remove EPROM from motherboard, clear by UV light, re-program, and then insert back.

### **EV6 Bus**

EV6 Bus is the technology of Alpha processor from Digital Equipment Corporation. EV6 bus uses both rising and falling clock edge to transfer data, similar as DDR RAM or ATA/66 IDE bus.

EV6 Bus Speed = CPU external bus clock x 2.

**200 MHz EV6 bus**, 200MHz = 100 MHz external bus clock x 2

### **FCC DoC (Declaration of Conformity)**

The DoC is component certification standard of FCC EMI regulations. This standard allows DIY component (such as motherboard) to apply DoC label separately without a shielding of housing.

***FC-PGA (Flip Chip-Pin Grid Array)***

FC means Flip Chip, FC-PGA is a package of Intel for Pentium III for 0.18 $\mu$ m process CPU, which can be plugged into SKT370 socket.

***FC-PGA2 (Flip Chip-Pin Grid Array)***

After FC-PGA, FC-PGA2 is the package for 0.13 $\mu$ m process CPU developed by Intel, which can be plugged into SKT423/478 socket as well.

***Flash ROM***

Flash ROM can be re-programmed by electronic signals. It is easier for BIOS to upgrade by a flash utility, but it is also easier to be infected by virus. Because of increase of new functions, BIOS size is increased from 64KB to 512KB (4M bit).

***Hyper Threading***

Hyper-Threading technology is an innovative design from Intel that enables multi-threaded software applications to process threads in parallel within each processor resulting in increased utilization of processor execution resources. As a result, an average improvement of ~40% in CPU resource utilization yields higher processing throughput.

**IEEE 1394**

IEEE 1394, which also called Firewire, is a serial data transfer protocol and interconnection system. The main feature of the Firewire that assures its adoption for the digital video and audio (A/V) consumer application is its low cost. Fire wire interface is capable of supporting various high-end digital A/V applications, such as consumer A/V device control and signal routing, Digital Video (DV) editing, home networking, and more than 32 channels of digital mixing. Gone are those days of expensive video capture cards. Firewire allows for video capture from both newer DV camcorders with Firewire ports and older analog equipment using A/V to Firewire converters.

The advantages of the IEEE1394:

**High data transfer rate** – Start from 400 Mbps, (with 800/1600/3200 Mbps coming soon), which is about 30 times faster than USB 1.1.

**Supports up to 63 devices** (16 - daisy chained) with cable length up to about 4.5 m (14 feet).

**Hot-pluggable** (like USB). No need to turn of your device to connect or disconnect, and you don't need to reboot your PC. Also, it is a plug-and-play bus.

**IEEE1394 is very easy to connect** (Like USB1.1/2/0).

**Parity Bit**

The parity mode uses 1 parity bit for each byte, normally it is even parity mode, that is, each time the memory data is updated, parity bit will be adjusted to have even count "1" for each byte. When next time, if memory is read with odd number of "1", the parity error is occurred and this is called single bit error detection.

**PCI (Peripheral Component Interface) Bus**

Developed by Intel, Peripheral Component Interconnect (PCI) is a local bus standard. A bus is a channel used to transfer data to (input) and from (output) a computer and to or from a peripheral device. Most PCs have a PCI bus usually implemented at 32-bits providing a 33 MHz clock speed with a throughput rate of 133 MBps.

**PDF Format**

With PDF file, it is easy to do universal document exchange. Virtually any document may be converted in Portable Document Format (PDF). Contents in PDF documents are exactly the same as the original file, including fonts and graphics, and they can be distributed by e-mail or stored on the World Wide Web, an intranet, a file system, or a CD-ROM for other users to view on any platforms. You may download Acrobat Reader in order to read PDF file from its website ([www.adobe.com](http://www.adobe.com)).

**PnP (Plug and Play)**

Oversimplified, Plug-and-Play automatically tells the software (device drivers) where to find various pieces of hardware (devices) such as modems, network cards, sound cards, etc. Plug-and-Play's task is to match up physical devices with the software (device drivers) that operates them and to establish channels of communication between each physical device and its driver.

**POST (Power-On Self Test)**

The BIOS self-test procedure after power-on, sometimes, it is the first or the second screen shown on your monitor during system boot.

**PSB (Processor System Bus) Clock**

PSB Clock means the external bus clock of CPU.

CPU internal clock = CPU PSB Clock x CPU Clock Ratio

**RDRAM (Rambus Dynamic Random Access Memory)**

A DRAM technology developed by Rambus Corporation\*, to achieve high speed of memory through the use of multiple channels in parallel by 16-bits. Basically, RDRAM uses new structure of Multibank, which is quite different from FPM, EDO, SDRAM. Using different memory module as well, RDRAM uses "RIMM" with transfer rate of 600/700/800MHz, providing bandwidth as high to 1.6GB.

**RIMM (Rambus Inline Memory Module)**

184-pin memory module that supports [RDRAM](#) memory technology. A RIMM memory module may contain up to maximum of 16 RDRAM devices.

**SDRAM (Synchronous DRAM)**

SDRAM is one of the DRAM technologies that allow DRAM to use the same clock as the CPU host bus (EDO and FPM are asynchronous and do not have clock signal). It is similar as PDSRAM to use burst mode transfer. SDRAM comes in 64-bit 168-pin DIMM and operates at 3.3V, and have been gradually replaced by DDR RAM.



**SATA (Serial ATA)**

The Serial ATA specification is designed to overcome speed limitations while enabling the storage interface to scale with the growing media rate demands of PC platforms. Serial ATA is to replace parallel [ATA](#) with the compatibility with existing operating systems and drivers, adding performance headroom for years to come. It is developed with data transfer rate of 150 Mbytes/second, and 300MB/s, 600M/b/s to come. It reduces voltage and pins count requirements and can be implemented with thin and easy to route cables.

**SMBus (System Management Bus)**

SMBus is also called I<sup>2</sup>C bus. It is a two-wire bus developed for component communication (especially for semiconductor IC). For example, set clock of clock generator for jumper-less motherboard. The data transfer rate of SMBus is only 100Kbit/s, it allows one host to communicate with CPU and many masters and slaves to send/receive message.

**SPD (Serial Presence Detect)**

SPD is a small ROM or [EEPROM](#) device resided on the DIMM or [RIMM](#). SPD stores memory module information such as DRAM timing and chip parameters. SPD can be used by [BIOS](#) to decide best timing for this DIMM or RIMM.

**USB 2.0 (Universal Serial Bus)**

A Universal Serial Bus (USB) is an external bus (an interconnection) standard that supports data transfer rates of 12 Mbps. A single USB port can be used to connect up to 127 peripheral devices, such as mouse, modems and keyboards. Introduced in 1996, USB has completed replaced serial and parallel ports. It also supports plug-and-play installations and hot plugging Plug-and-play is the ability to add and remove devices to a computer while the computer is running and have the operating system automatically

recognize the change. USB 2.0, which supports data transfer rates of 480 Mbps, has been widely used in motherboard these days.

### **VCM (Virtual Channel Memory)**

NEC's Virtual Channel Memory (VCM) is a new DRAM core architecture that dramatically improves the memory system's ability to service multimedia requirements. VCM increases memory bus efficiency and performance of any DRAM technology by providing a set of fast static registers between the memory core and I/O pins. Using VCM technology results in reduced data access latency and reduced power consumption.

### **Wireless LAN – 802.11b**

802.11 is a specification developed by IEEE and Wireless LAN technology, which is an interface between a wireless client and a base station or between two wireless clients.

802.11 family includes the following specifications and with more coming:

**802.11** = 1 or 2 Mbps transmission in the 2.4 GHz band, using either frequency hopping spread spectrum (FHSS) or direct sequence spread spectrum (DSSS)).

**802.11a** = 54 Mbps in the 5GHz band, using orthogonal frequency division multiplexing)

**802.11b** (11 Mbps transmission in the 2.4 GHz band, using direct sequence spread spectrum (DSSS)).

### **ZIP file**

A compressed file format to reduce file size. To unzip file, run shareware PKUNZIP (<http://www.pkware.com/>) for DOS and other operating system or WINZIP (<http://www.winzip.com/>) for windows environment.



# Troubleshooting

If you encounter any trouble to boot your system, follow the procedures accordingly to resolve the problem.

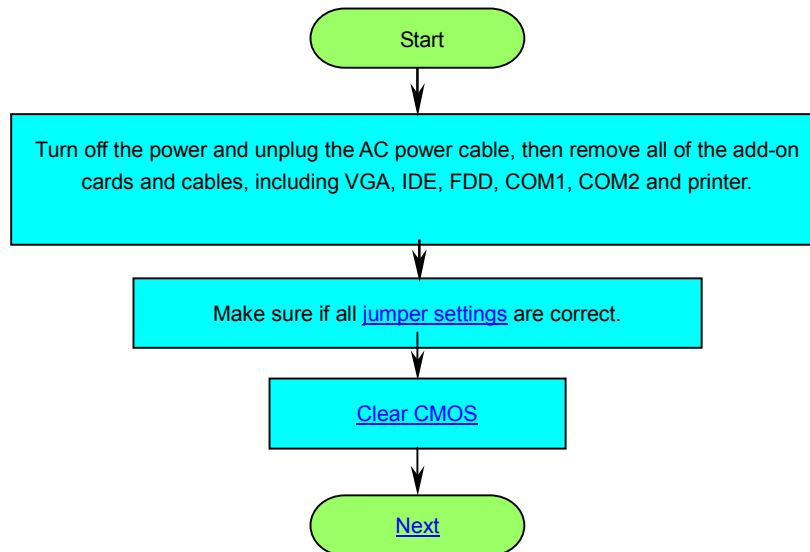

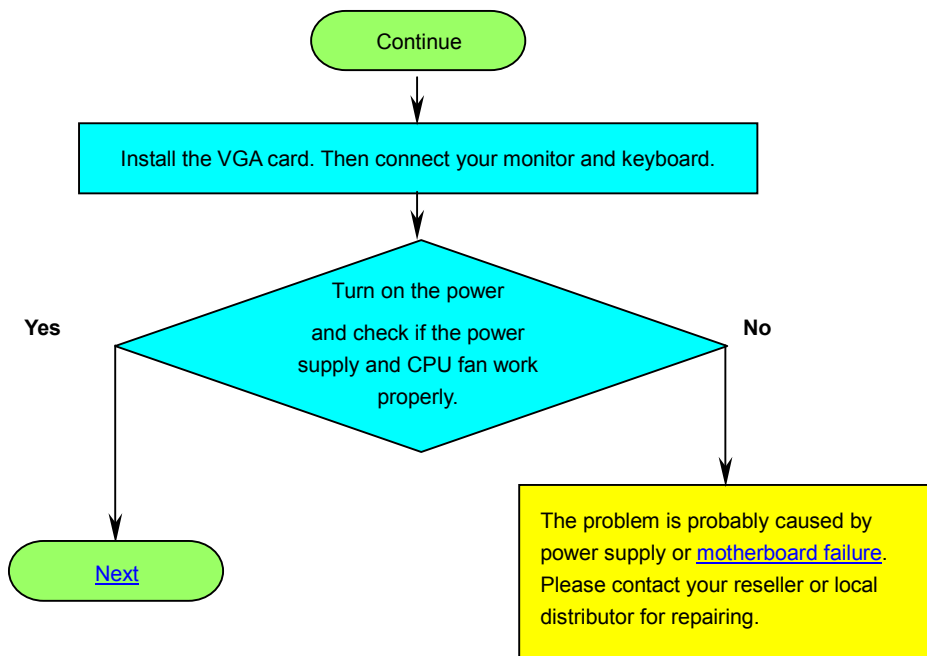

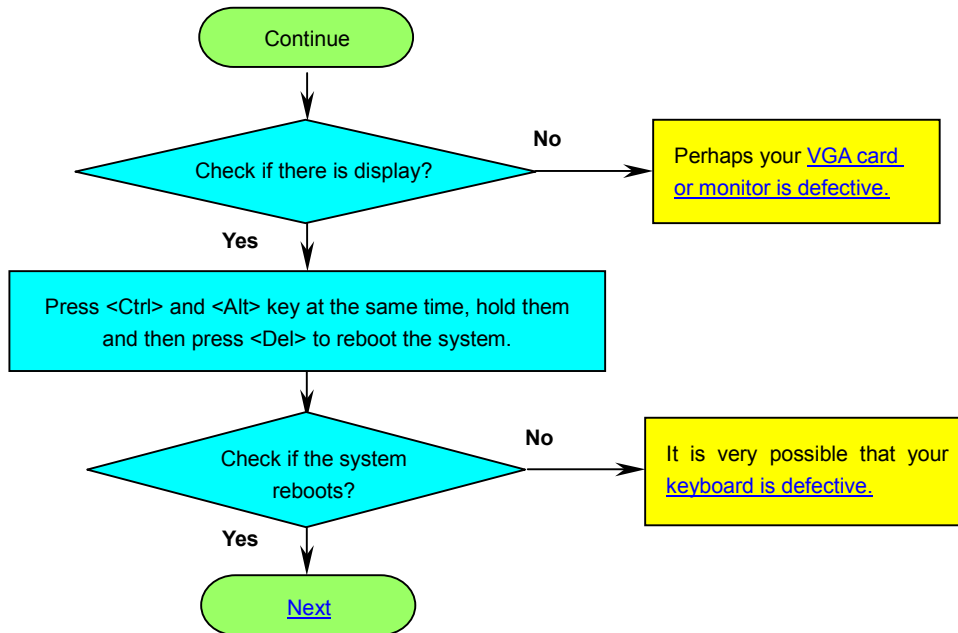

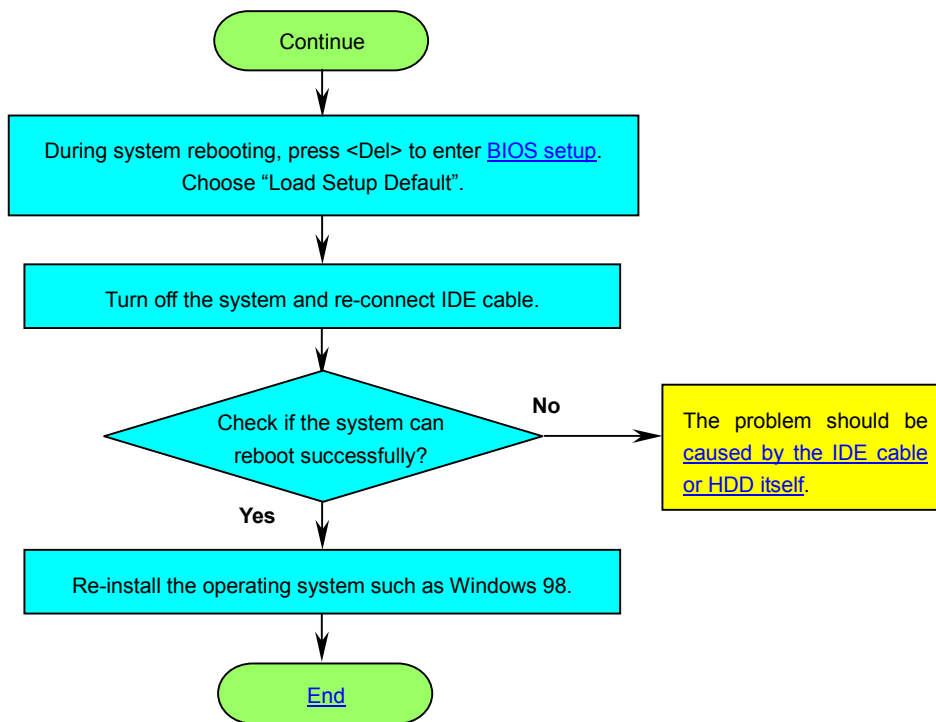



# Technical Support

Dear Customer,

Thanks for choosing AOpen products. To provide the best and fastest service to our customer is our first priority. However, we receive numerous emails and phone-calls worldwide everyday, it is very hard for us to serve everyone on time. We recommend you follow the procedures below and seek help before contact us. With your help, we can then continue to provide the best quality service to more customers.

Thanks very much for your understanding!

AOpen Technical Supporting Team

**1**

**Online Manual:** To download manual, please log on and then select your preferred language. Under "Type" directory, choose "Manuals" to go to our manual database. You can also find the manual and EIG in AOpen Bonus Pack.

<http://club.aopen.com.tw/downloads>

**2**

**Test Report:** We recommend you to choose board/card/device from the compatibility test reports for assembling your PC. It may prevent incompatibility problems.

<http://english.aopen.com.tw/tech/report/default.htm>

**3**

**FAQ:** Here we list problems that users often encounter and FAQ (Frequently Asked Questions). You may select your preferred language after log on and find a solution to your problem.

<http://club.aopen.com.tw/faq/>

**4**

**Download Software:** After log on and having language selected, you may get the latest updated BIOS/utility and drivers you need under "Type" directory. In most case, newer versions of drivers and BIOS have solved earlier bugs or compatibility problems.

<http://club.aopen.com.tw/downloads>

**5**

**eForum:** AOpen eForum is provided to discuss our products with other users, in which your problem probably had been discussed before or will be answered. After log on, you may select your preferred language under "Multi-language".

<http://club.aopen.com.tw/forum/>

**6**

**Contact Distributors/Resellers:** We sell our products through resellers and integrators. They should know your system configuration very well and should be able to solve your problem efficiently and provide important reference for you.

**7**

**Contact Us:** Please prepare detail system configuration and error symptom before contacting us. The **part number**, **serial number** and **BIOS version** are also very helpful.

### Part Number and Serial Number

The Part Number and Serial number are printed on bar code label. You can find this bar code label on the outside packing or on component side of PCB. For example:

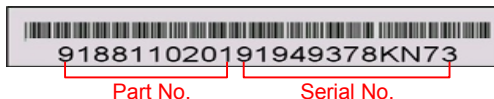

**P/N: 91.88110.201** is part number, **S/N: 91949378KN73** is serial number.



**Model name and BIOS version**

Model name and BIOS version can be found on upper left corner of first boot screen ([POST](#) screen). For example:

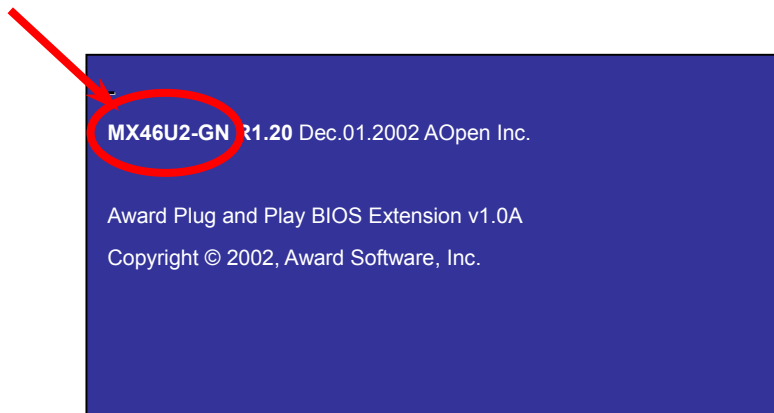

**MX46U2-GN** is model name of motherboard; **R1.20** is BIOS version.



# Product Registration

ClubAOpen

Welcome to AOpen Inc.



Thank you for choosing AOpen product. AOpen encourages you to spend few minutes in completing the following product registration. To register your product will ensure the high quality of services from AOpen. After the registration, you will:

- Have opportunities to play online slot machine and win a prize from AOpen by accumulating your bonuses for later prize exchange.
- Be upgraded to gold membership of Club AOpen program.
- Receive email notification about product safety alerts. Its purpose is to alert consumers quickly and conveniently when products contain technical issues.
- Receive email notification about latest product's announcements.
- Be able to personalize your AOpen web pages.
- Receive e-mail notification about latest BIOS/Driver/Software release information.
- Have opportunities to participate special product promotional programs.
- Enjoy higher service priority to receive technical assistance provided by AOpen specialists worldwide.
- Be able to join the discussions of web-based news groups.

AOpen makes sure that the information you provide is encrypted, so that it cannot be read or intercepted by other people or companies. Further, AOpen will not disclose any of information you submitted under any conditions. Please consult our [online privacy policy](#) for further information on our company policy.

**Note:** *If registering products purchased from different dealers/retails and/or purchased on different dates, please submit a separate form for each product.*



## How to Contact Us



Please do not hesitate contact us if you have any problem about our products. Any opinion will be appreciated.

<p>Pacific Rim AOpen Inc. Tel: 886-2-3789-5888 Fax: 886-2-3789-5899</p>	<p>Europe AOpen Computer b.v. Tel: 31-73-645-9516 Fax: 31-73-645-9604</p>	<p>America AOpen America Inc. Tel: 1-510-489-8928 Fax: 1-510-489-1998</p>
<p>China 艾爾鵬國際貿易(上海)有限公司 Tel: 86-21-6225-8622 Fax: 86-21-6225-7926</p>	<p>Germany AOpen Computer GmbH. Tel: 49-1805-559191 Fax: 49-2102-157799</p>	<p>Japan AOpen Japan Inc. Tel: 81-048-290-1800 Fax: 81-048-290-1820</p>

Web Site: <http://english.aopen.com.tw/>

E-mail: Send us email by going through the contact form below.

English <http://english.aopen.com.tw/tech/default.htm>

Japanese <http://www.aopen.co.jp/tech/default.htm>

Chinese <http://www.aopen.com.tw/tech/default.htm>

German <http://www.aopencom.de/tech/default.htm>

Simplified Chinese <http://www.aopen.com.cn/tech/default.htm>