

MV11
PPGA Celeron processor
Based AGP MAINBOARD
User's Manual

Shuttle® Spacewalker™ MV11

PPGA Celeron® processor based AGPset Mainboard

Manual Version 1.0

Copyright

Copyright® 1999 by Shuttle® Inc. All Rights Reserved.

No part of this publication may be reproduced, transcribed, stored in a retrieval system, translated into any language, or transmitted in any form or by any means, electronic, mechanical, magnetic, optical, chemical, photocopying, manual, or otherwise, without prior written permission from Shuttle® Inc.

Disclaimer

Shuttle® Inc. shall not be liable for any incidental or consequential damages resulting from the performance or use of this product.

This company makes no representations or warranties regarding the contents of this manual. Information in this manual has been carefully checked for reliability; however, no guarantee is given as to the correctness of the contents. In the interest of continued product improvement, this company reserves the right to revise the manual or include changes in the specifications of the product described within it at any time without notice and without obligation to notify any person of such revision or changes. The information contained in this manual is provided for general use by the customers.

Trademarks

Spacewalker is a registered trademark of Shuttle Inc.

Intel, Celeron is a registered trademarks of Intel Corporation.

PC/ATX is a registered trademark of International Business Machines(IBM) Corporation

PS/2 is a registered trademark of IBM Corporation.

AWARD is a registered trademark of Award Software Inc.

Microsoft and Windows are registered trademarks of Microsoft Corporation.

General Notice: Other brand and product names used herein are for identification purposes only and may be trademarks of their respective owners.

Federal Communications Commission (FCC) Compliance Notice

This equipment has been tested and found to comply with the limits for a Class B digital device, pursuant to Part 15 of FCC Rules. These limits are designed to provide reasonable protection against harmful interference in a residential installation.

This equipment generates, uses and can radiate radio frequency energy. If not installed and used properly, in strict accordance with the manufacturer's instructions, may cause harmful interference to radio communications. However, there is no guarantee that interference will not occur in a particular installation. If this equipment does cause interference to radio or television reception, which can be determined by turning the equipment off and on, the user is encouraged to try to correct the interference by one or more of the following measures :

- Reorient or relocate the receiving antenna.
- Increase the separation between the equipment and receiver.
- Connect the equipment into an outlet on a circuit different from that to which the receiver is connected.
- Consult the dealer or an experienced radio/television technician for help and for additional suggestions.

The user may find the following booklet prepared by the Federal Communications Commission helpful "How to Identify and Resolve Radio-TV Interference Problems." This booklet is available from the U.S. Government Printing Office, Washington, DC 20402, Stock 004-000-00345-4

CE Notice

This device complies with the requirements of the EEC directive 89/336/EEC with regard to EMC (Electromagnetic Compatibility). Following standards are applied to this product, in order to achieve compliance with the EMC:

- Immunity is in accordance with EN 50082-1 (1992).
- Emissions are in accordance with EN 55022 (1987) Class B.



TABLE OF CONTENTS

CHAPTER 1 INTRODUCTION	4
CHAPTER 2 FEATURES	5
2.1 Specifications	5
2.2 Accessories of MB11	7
2.3 Accessories of MZ11	8
CHAPTER 3 HARDWARE INSTALLATION	9
3.1 The Installation PPGA Celeron Processor	9
3.2 Jumpers	10
CPU Host Clock and Ratio Selection - JP2, J113 and JP9	10
Clear CMOS - JP11	11
Keyboard & PS/2 Mouse Power-on Setting - JP1	11
Wake-On-LAN Setting - JP26	11
On Board Audio Controller Setting - JP25	12
3.3 Connectors	13
Front Panel Connectors	13
Back Panel Connectors	14
Other Connectors	15
CHAPTER 4 MEMORY CONFIGURATION	17
CHAPTER 5 FLASH UTILITY	18
CHAPTER 6 AWARD BIOS SETUP	20
The Main Menu	21
Standard CMOS Setup	23
BIOS Features Setup	25
Chipset Features Setup	28
Power Management Setup	31
PNP/PCI Configuration Setup	34
CPU Features Setup	36
Integrated Peripherals	38
Password Setting	42

CHAPTER 7 ONBOARD ATi AGP VGA	44
General Features	44
Windows 95/98 Drivers	45
Windows NT4.0 Driver	48
CHAPTER 8 ONBOARD CREATIVE 3D AUDIO	51
Introduce	51
General Specification	52
Install Creative ES1373 Windows 95/98 Driver	53
Install Creative ES1373 Windows NT4.0 Driver	56

1

INTRODUCTION

Congratulations on your purchase of the **Shuttle Spacewalker™ MB11/MZ11** computer mainboard.

The MB11/MZ11 mainboard is a highly integrated IBM PC/ATX compatible system board designed to meet the industry's most demanding desktop applications.

The MB11 based on the Intel 82443BX AGPset chipset and MZ11 based on the 82443ZX AGPset chipset which both support up to 500MHz PPGA Celeron processor with MMX technology.

MB11/MZ11 is equipped with an Accelerated Graphics Port (A.G.P.), a high-performance interconnect for graphic-intensive application, such as 3D applications. The A.G.P. is independent of the PCI bus and is designed to exclusively use with graphical-display devices. The MB11/MZ11 supports 3.3V A.G.P. devices with data transfer rates up to 133 MHz, allowing data throughput of 500 MB/sec.

The Intel's 82443BX/82443ZX AGPset chipset provide an integrated Bus Mastering IDE controller with two high performance IDE interfaces which allows up to four IDE devices connection and up to 33 MB/sec of data transfer rates.

Onboard Creative ES1373 is an advanced PCI audio controller, it is compatible with Microsoft Windows, DirectX and Adlib Music Synthesizer, Sound Blaster Pro and supports thousands of DOS games.

The on-board I/O controller provides standard PC I/O functions:

floppy drive interface, two FIFO serial ports, an InDA device port and a SPP/EPP/ECP capable parallel port.

MB11 and MZ11 are built with three PCI local bus slots providing a high bandwidth data path for data-movement intensive functions such as graphics, and with one ISA slot.

MB11/MZ11 provides the foundation for cost effective, high performance and highly expandable platforms, which delivers the latest in the Intel PPGA Celeron processor and new advanced chipset technology.

2

FEATURES

The MB11/MZ11 mainboard is carefully designed for the demanding PC user who wants high performance and maximum intelligent features in a compact package.

2.1 Specifications

Chipset:

MB11 : Features Intel's 82443BX AGPset with I/O subsystems.

MZ11 : Features Intel's 82443ZX AGPset with I/O subsystems.

CPU Support:

Intel PPGA Celeron processor 300 ~ 500 MHz.

Versatile Memory Supports:

MB11 : Supports **three banks of normal or PC/100 SDRAM** maximum memory size up to 768 MB.

MZ11 : Supports **two banks of normal or PC/100 SDRAM** maximum memory size up to 512 MB.

PCI and ISA Expansion Slots:

Provides three 32-bit PCI slots and one 16-bit ISA slot.

Onboard I/O:

Provides a variety of I/O interfaces:

- 1 x Floppy interface for 3.5-inch FDD or 5.25-inch FDD.
- 1 x PS/2 mouse connector.
- 1 x PS/2 Keyboard connector.
- 2 x DB9 Serial connectors 16C550 UARTS compatible.
- 1 x Infrared communications port ASKIR and HPSIR compatible.
(Serial port COM2 can also be re-directed to an external IrDA Adapter for wireless connections.)
- 1 x DB25 Parallel port supporting Standard Parallel Port and Bi-directional (SPP), Enhanced Parallel Port (EPP), and Extended Capabilities Port (ECP) data transmission schemes.

Onboard PCI Bus Master IDE Controller:

Two Ultra DMA/33 Bus Dual-channel Master IDEports provide support to a maximum of **four IDE devices** (one Master and one Slave per channel). The IDE Bus implements data transfer speeds of up to 33MB/sec IDE and also supports Enhanced PIO Modes 3 & 4 and Bus Master IDE DMA Mode 2 devices.

Onboard Audio Controller:

Provides Creative ES1373 AC97 digital controller, advanced 64 polyphonic wavetable synthesis with additional DOS support. Full-Duplex Record/Playback at up to 48KHz and supports Microsoft DirectSound 3D. Digital effects engine for reverb, chorus, tone control.

Onboard AGP VGA Controller:

Provides ATi Rage Pro Chip, support 3D graphics visual and texturing enhancements. 8MB SDRAM on board High-Speed 64-Bit 100MHz Interface.

ATX Power Supply Connector:

ATX power supply unit can connect to the **20-pin ATX power connector** onboard, supporting Suspend and soft-on/off by dual-function power button.

System BIOS:

Provides licensed Award V4.51PG BIOS on 2MB Flash EEPROM. Supports Green PC, Desktop Management Interface (DMI) and bundled with NCR SCSI BIOS.

ACPI:

Support **ACPI (Advanced Configuration and Power Interface)** function. ACPI provide more Energy Saving Features for the future operating system supporting OS Direct Power Management (OSPM) functionality.

Board Size:

MicroATX form factor, dimension 244mm x 220mm.

Advanced Features:

- **Low EMI** -- Using built-in Spread Spectrum with 1.5% modulation and automatic clock shut-off of unused PCI/SDRAMS slots to reduce the Electromagnetic Interference (EMI).
- **Dual Function Power Button**-- The system can be one of two states, one is Suspend mode and the other is the Soft-off mode. Pushing the power button for less than 4 seconds will place the system into Suspend mode. When push the power button for more than 4 seconds, the system enters the Soft-off mode.
- **Wake-On-LAN** --The Wake-On-LAN connector onboard can be attached to a network card that supports this function to wake up the system via the LAN. (This function support Intel LAN card only).
- **Modem Ring Power-on** --The system can be powered on automatically by activation of modem ring.
- **PS/2 Keyboard & Mouse Power-on** --The system will power-on automatically by stroke keyboard or double click PS/2 mouse.

Optional Features:

- **Voltages Monitoring**-- Various voltages of key elements, such as the CPU, and other critical system voltage levels are monitored to ensure stable current reach to mainboard components. System voltages include V_{CORE}/VL2 on CPU, and +5V, +12V, -5V, -12V on system.
- **FAN Status Monitoring**-- To prevent CPU overheat, CPU fans is monitored for RPM and failure. (CPU Cooling FAN with RPM sensor is required)

2.2 Accessories Of MB11

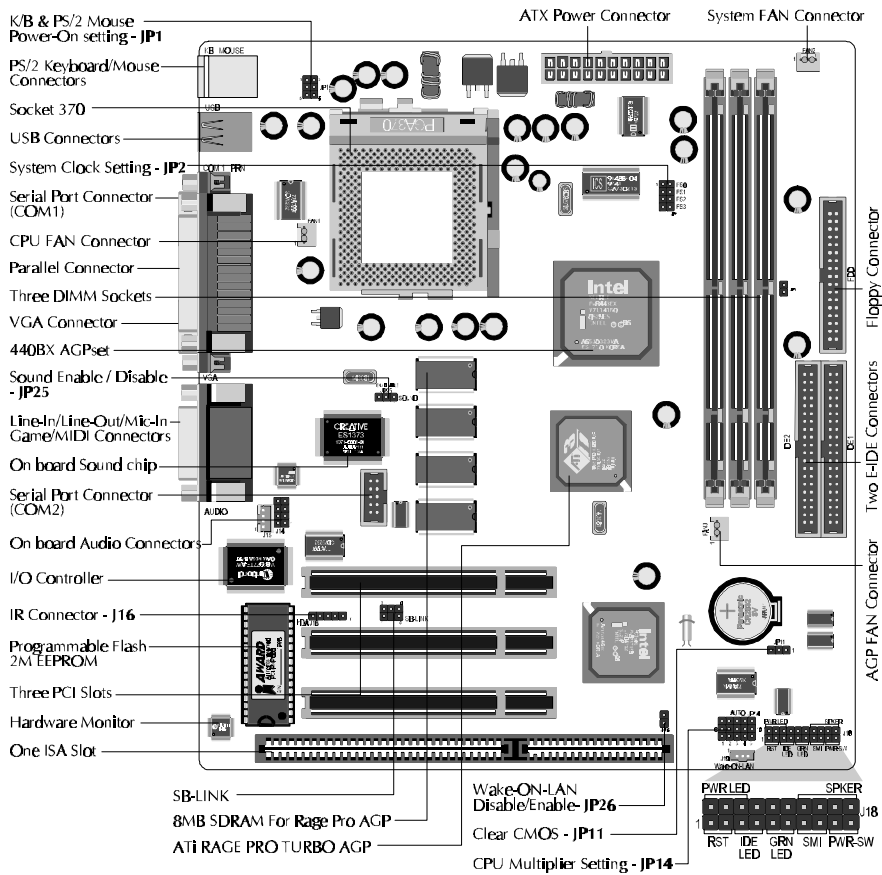

2.3 Accessories Of MZ11

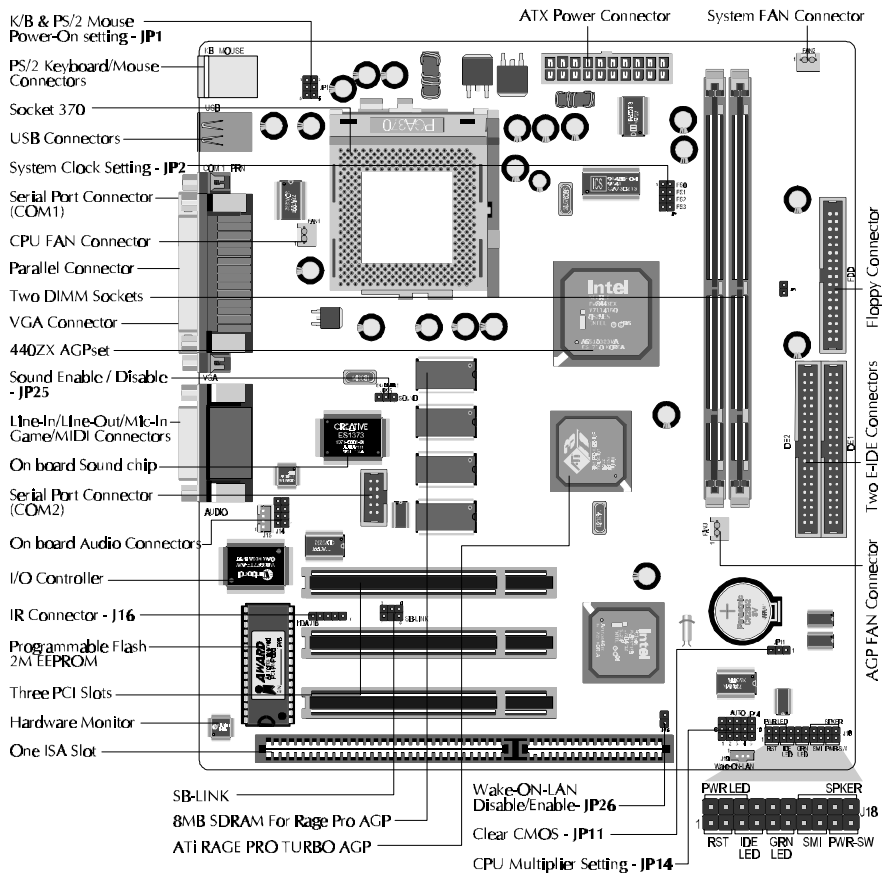

3

HARDWARE INSTALLATION

3.1 The Installation PPGA Celeron Processor

MB11/MZ11 mainboard provides a 370-pin ZIF Socket370 for Intel PPGA Celeron CPU. The CPU that came with the mainboard should have a fan attached to it to prevent overheating. If this is not the case then purchase a fan before you turn on your system. To install a CPU, first turn off your system and remove its cover. Locate the ZIF Socket370 and open it by first pulling the lever sideways away from the socket then upwards to a 90-degree right angle. Insert the CPU with the correct orientation as shown.(Figure 3-1) Use the notched corner of the CPU as your guide. The notched corner should point towards the end of the lever. Notice that there are two blank area where one hole is missing from that corner of the square array of pin holes. Because the CPU has a corner pin for two of the four corner, the CPU will only fit in the one orientation, hold down on the CPU and close the socket's lever.

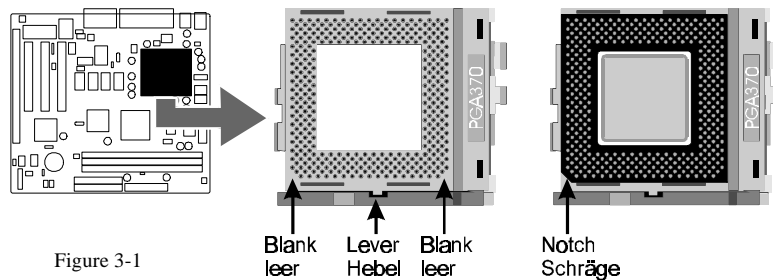

Figure 3-1

Then you should have a CPU fan that will cover the face of the CPU. Apply thermal jelly to the CPU metallic top and then install the fan onto the CPU. (Figure 3-2)

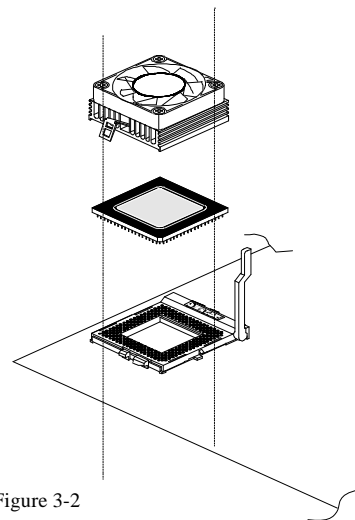



Figure 3-2

3.2 Jumpers

Several hardware settings are made through the use of jumper caps to connect jumper pins on the main board. The jumper's pin 1 on main board will be on the top or on the left when holding the main board with the keyboard connector away from yourself.

Jumpers with two pins will be shown as  for Close (On) and  for Open (Off). To connect the pins, simply place a plastic jumper cap over the two pins.

CPU Host Clock and Ratio Selection - JP2 and JP14

MB11/MZ11 mainboard features a clock generator to provide adjustable system clock frequency. Jumper JP2 determine the system clock frequency 66MHz to 100MHz. JP14 is a 15-pin jumper which determine the processor clock ratio from 3X to 8X.

Figure 3-3 shows the position of JP2 and JP14 on the mainboard.

Table 3-1 shows adjustable System clock on jumper JP2.

Table 3-2 shows adjustable CPU Clock Ratio on jumper group JP14.

Note: Present PPGA Celeron CPU Clock Ratio is fixed and unable to adjust, for those processors, JP14 is not functional.

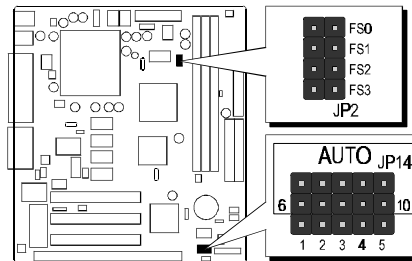

Figure 3-3

















CPU Host Clock	JP2	CPU Clock Ratio	JP14	CPU Clock Ratio	JP14
66 MHz		3 x		6 x (400 / 66)	
75 MHz		3.5 x (350 / 100)		6.5 x (433 / 66)	
83 MHz		4 x (400 / 100)		7 x (466 / 66)	
100 MHz		4.5 x (300 / 66) (450 / 100)		7.5 x (500 / 66)	
103 MHz		5 x (333 / 66) (500 / 100)		8 x	
		5.5 x (366 / 66)			

Table 3-1

Table 3-2

Clear CMOS - JP11

MB11/MZ11 mainboard supports jumper **JP11** for discharging mainboard's CMOS memory.

This jumper can clear the CMOS data stored in the I/O chip. To clear the CMOS data please follow listed steps:

- 1) Turn off the PC,
- 2) Remove mini jumper from JP11 pin 1-2,
- 3) Insert mini jumper to JP11 pin 2-3 for a brief while,
- 4) Remove mini jumper from JP11 in 2-3,
- 5) Reinsert mini jumper to JP11 pin 1-2,
- 6) Turn on the PC.

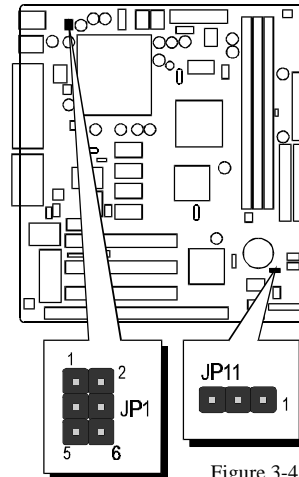

Figure 3-4

K/B & PS/2 Mouse Power-On Setting - JP1

MB11/MZ11 mainboard provides an optional power-on function by stroke any key (or hot-key) on keyboard or double click on PS/2 mouse.

Note: Power-on by serial mouse is not supported

JP1 is the jumper used to set the functions of keyboard & PS/2 mouse power-on Enabled or Disabled.

When you enabled K/B & PS/2 Mouse Power-ON function, you also have to set the proper item on **POWER ON function** category of **Integrated Peripherals** of BIOS setup.

K/B & PS/2 Mouse Power-On JP1	
Keyboard & PS/2 Mouse Power-On Disabled	Keyboard & PS/2 Mouse Power-On Enabled
PS/2 Mouse Power-On Enabled	Keyboard Power-On Enabled

Table 3-3

Wake-On-LAN Setting - JP26

JP26 Close (On)
Wake-On-LAN Function Enabled

JP26 Open (Off)
Wake-On-LAN Function Disabled

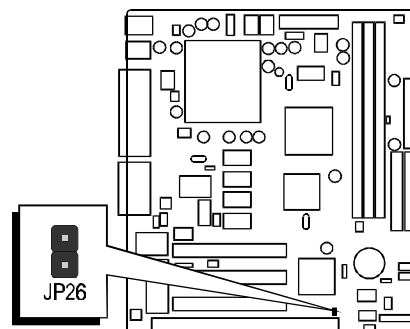



Figure 3-5

On Board Audio Controller Setting - JP25

MB11/MZ11 mainboard provides on-board PnP 64 voices wavetable sound chip which based on Creative ES1373 PnP 3D integrated audio controller chip. Jumper JP25 is used to enable or disable it.

-  1 JP25 Pin 2-3 Close (On)
On-board Audio Controller Enabled (default)
-  1 JP25 Pin 1-2 Close (On)
On-board Audio Controller Disabled

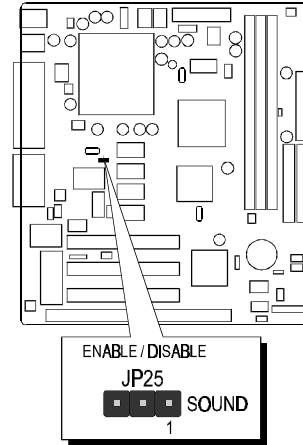

Figure 3-6

3.3 Connectors

Front Panel Connectors (J18)

PWR-LED Connector - PWR-LED

Attach 3-pin Power-LED connector cable from the housing front panel to PWR-LED header on the mainboard. The power LED stays lights while the system is running.

Speaker Connector - SPK

Attach the PC speaker cable from the case to the 4-pin speaker connector (SPK).

Hardware Reset Connector - RST

Attach the 2-pin hardware reset switch cable to RST header. Closing the reset switch causes the system to restart.

HDD LED Connector - IDE LED

Attach the connector cable from the IDE device LED to the 2-pin IDE LED header. The HDD LED lights up whenever an IDE device is active.

Green LED Connector - GRN LED

Attach a 2-pin Green LED cable to it. The Green LED lights when the system get into power saving mode. The Green LED off when the system resume back to normal mode.

EPMI Connector - SMI

Hardware System Management Interface connector may attach a 2-pin momentary switch to it. When push it will force system get into power saving mode, and the system will resume when switch is pushed again.

ATX Power On/Off Switch Connector - PWR-SW

Attach a 2-pin momentary type switch to this connector for turning on or off your ATX power supply.

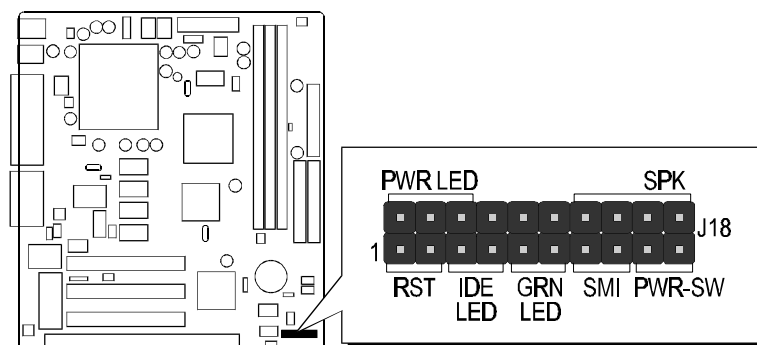

Figure 3-7

Back Panel Connectors

Locate the back panel connectors to attach all your external peripherals, such as parallel printer, VGA, Line-Out, Line-In, Mic-In, Game/MIDI, PS/2 mouse, PS/2 keyboard, and USB devices. Plug the signal cable from each peripheral device directly into the corresponding connector at the back panel of the mainboard, as explained below:

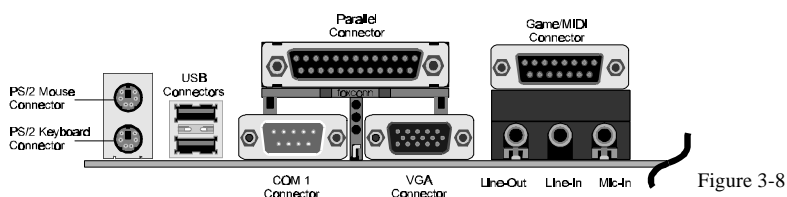

Figure 3-8

PS/2 Keyboard & PS/2 Mouse Connector

Two 6-pin female PS/2 keyboard & Mouse connectors are located at the rear panel of the mainboard. Depending on the computer housing you use (desktop or minitower), the PS/2 Mouse connector is situated at the top of the PS/2 Keyboard connector when the mainboard is laid into a desktop, as opposed to a mini-tower where the PS/2 Mouse connector is located at the right of the PS/2 Keyboard's. Plug the PS/2 keyboard and mouse jacks into their corresponding connectors.

USB1/USB2 Port Connectors

Two female connectors USB1/USB2 share the same USB (Universal Serial Bus) bracket at the rear panel of your mainboard. Plug each USB device jack into an available USB1/USB2 connector.

COM1 Connectors

This mainboard can accommodate up to one serial device on COM1. Attach each serial device cable to the DB9 serial port COM1 at the back panel of your computer.

Parallel Port Connector

One DB25 female parallel connector is located at the rear panel of the mainboard. Plug the connection cable from your parallel device (printer, scanner, etc.) into this connector.

VGA Connector

Attach 15-pin VGA cable to this connector.

Game/MIDI Connector

The Game/MIDI port is a 15-pin female connector, please refer to "CHAPTER 6 ON BOARD SOUND CHIP SETTING" "Connecting Audio Devices to MB11/MZ11".

Line-Out/Line-In/Mic-In Connectors

The Line-Out/Line-In/Mic-In ports are 1/8-inch connectors, please refer to "CHAPTER 6 ON BOARD SOUND CHIP SETTING" "Connecting Audio Devices to MB11/MZ11".

Other Connectors

ATX Power Supply Connector - J2

It is a 20-pin male header connector is connected to the ATX power supply. The plug of the power supply will only insert in one orientation because of the different hole shade and size. Find the proper orientation and push down firmly making sure that the pins are aligned.

Figure 3-9 shows ATX Power Supply Connector.

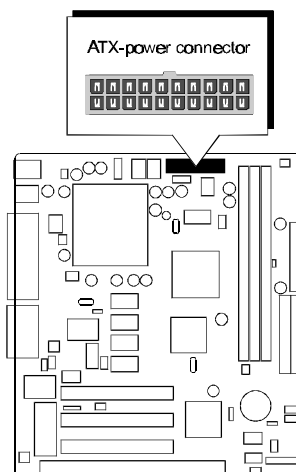

Figure 3-9

IR Connector - J16

If you have an Infrared device, this mainboard can implement IR (Infrared) transfer and meet both ASKIR and HPSIR specifications. To enable the IR transfer function, follow these steps:

- Step 1.** Attach the 5-pin infrared device cable to J16 connector. (Refer to the above diagram for IR pin assignment.)
- Step 2.** Configure the Infrared transfer mode in the UR2 Mode field of Integrated Peripherals menu in BIOS Setup. This mainboard supports IrDA 1.0, ASKIR, MIR 0.57M and MIR 1.15M transfer modes. FIR is not currently supported.

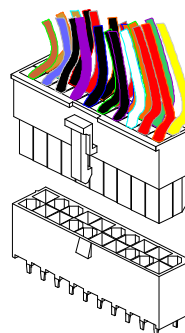

Figure 3-10

Enhanced IDE, Floppy and COM2 Connectors

The mainboard shipped with one 40-pin ribbon cable for IDE H.D.D, one 34-pin ribbon cable for F.D.D. and one 10-pin ribbon cable for COM2. Flat cables should be connected with the red stripe on the **pin 1** side of the connector.

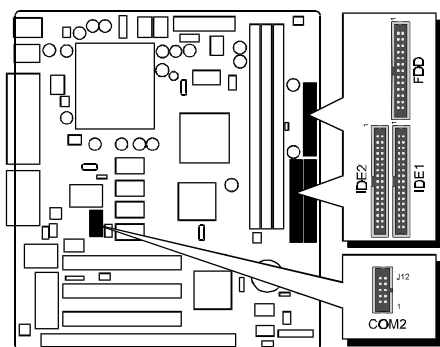

Figure 3-12

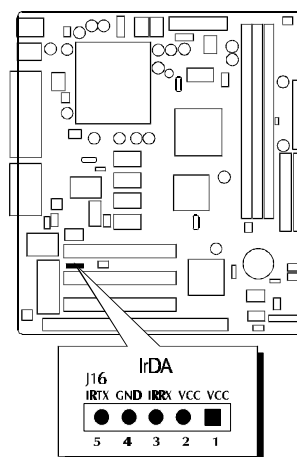

Figure 3-11

CPU, System & AGP cooling Fan Connectors - FAN1, FAN2 & FAN3

The main board provides three onboard 12V cooling fan power connectors. Depending on the fan maker, the wiring and plug may be different. The red wire should be connected to +12V and black wire should be connected to ground (GND).

Wake-On-LAN Connector - J19

Attach a 3-pin connector from the LAN card which supports the Wake-On-LAN (WOL) function. This function lets users wake up the connected system through the LAN card.

SB-Link Connector - SB-LINK

The main board provides a 2x3 pin SB-Link header accepts the Creative CT4600 series PCI sound cards with PCI solution to connect the legacy Sound Blaster compatible audio to the PCI bus.

CD Audio Connectors - J15 and J14

> CD-IN

Port J15 and J14 (2,4,6,8-pin) are used to attach CD-ROM audio connector.

J15 (CD_IN) pin assignment :

- 4 = Left Channel
- 3 = Ground
- 2 = Right Channel
- 1 = Ground



J14 (CD_IN) pin assignment :

- 8 = Right Channel
- 6 = Ground
- 4 = Ground
- 2 = Left Channel



> TAD

Port J14 (1,3,5,7-pin) can be used to connect a modem audio line to MB11/MZ11. You would use this connector when telephone answering machine software for input and output.

J17 (TAD) pin assignment:

- 7 = PHONE
- 5 = Ground
- 3 = Ground
- 1 = MONO

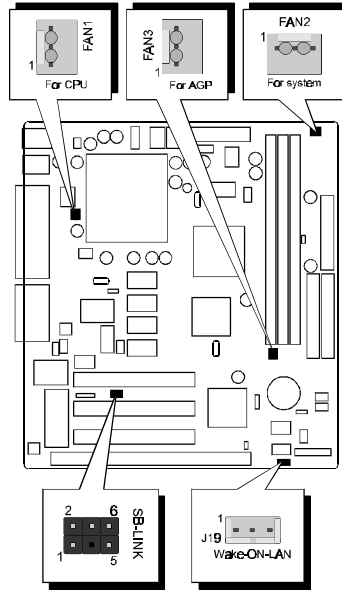

Figure 3-13

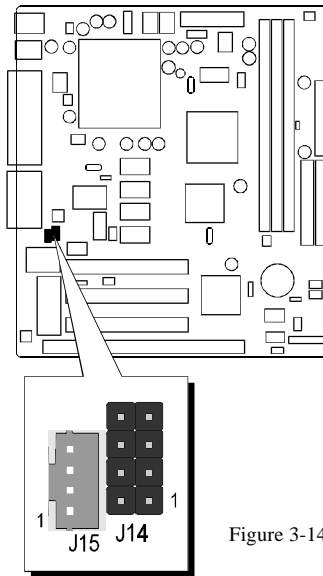

Figure 3-14

4

MEMORY CONFIGURATION

The MB11/MZ11 mainboard provides three/two 168-pin DIMM sockets that make it possible to install from 8MB up to 768/512MB of SDRAM. The DIMM socket support 8MB, 16MB, 32MB, 64MB, 128MB and 256MB 3.3V single- or double- side SDRAM DIMM.

The DIMM sockets are arranged in all banks of one socket each. Each bank provides a 64/72-bit wide data path.

MB11/MZ11 provides data integrity features including ECC (Error Checking and correcting) in the memory array. ECC mode provides single and multiple bit error detection.

Install memory in any or all of the banks in any combination as follows:

Mode	DIMM Socket	Memory Modules	Module Quantity
MB11	DIM1	8MB, 16MB, 32MB, 64MB, 128MB, 256MB 168-pin 3.3V SDRAM DIMM	x 1
	DIM2	8MB, 16MB, 32MB, 64MB, 128MB, 256MB 168-pin 3.3V SDRAM DIMM	x 1
	DIM3	8MB, 16MB, 32MB, 64MB, 128MB, 256MB 168-pin 3.3V SDRAM DIMM	x 1
MZ11	DIM1	8MB, 16MB, 32MB, 64MB, 128MB, 256MB 168-pin 3.3V SDRAM DIMM	x 1
	DIM2	8MB, 16MB, 32MB, 64MB, 128MB, 256MB 168-pin 3.3V SDRAM DIMM	x 1

Table 4-1

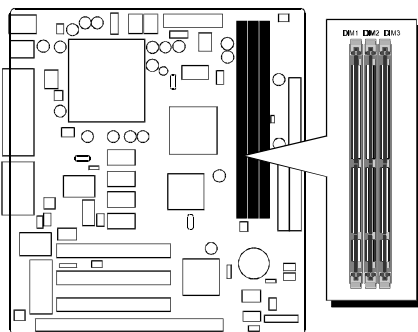

Figure 4-1 : MB11/MZ11 provides three DIMM sockets

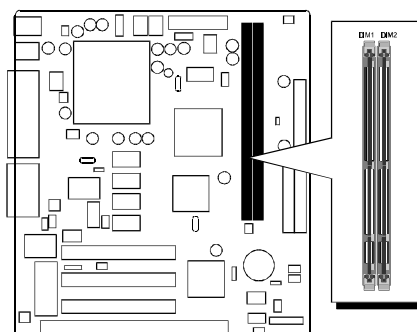

Figure 4-2 : provides two DIMM sockets

5

FLASH UTILITY

This chapter briefly discusses Award Flash utility in order to guide you through updating your old BIOS. The file name we use to program here is test.bin, and the file name to save old BIOS is MX11.OLD. Please note that those file names are not absolute. They are only examples to let you have a more clear understanding of the updating process.

How to Begin

1. Please type “awdf flash” and press the ENTER key to begin the updating process.
2. Once you enter, you will see a main menu displaying:
3. Move the cursor to “File Name to Program: ”
4. Type the program name “test.bin”, and then press the ENTER key.
5. At the bottom of the menu, you will be requested to answer:

“Do You Want to Save BIOS (Y/N)? ”

```
FLASH MEMORY WRITER v5.5
Copyright (C) 1996-1997, Award Software, Inc.

For 8-1440EX-M5135-2069JH2DC  DATE: 04/20/19
Flash Type - WINBOND 29EE011 /5U

File Name to Program : test.bin

Error Message: Do You Want To Save Bios (Y/N)
```

The following manual is intended to guide you through the process of both “No” and “Yes” cases respectively.

If “No”

If you do not wish to save the old BIOS:

1. Please type “N”, and then press the ENTER key.
2. Then you will be requested to answer:

“Are You Sure to Program? ”

3. Answer “N” if you do not want to program, and then it will exit.

If “Yes”

To save the old BIOS:

1. Please respond “Y”, and then press the ENTER key.
2. Move the cursor to “File Name to Save: “
3. Type file name “TEST.BIN”, and then press the ENTER key. (Your old BIOS will be saved in the file name you create. In this case, the old BIOS is saved in the file name, MX11.OLD).
4. Then you will be requested to answer:
“Are You Sure to Program (Y/N)? “

```
FLASH MEMORY WRITER v5.5
Copyright (C) 1996-1997, Award Software, Inc.

For 0-1440EX-MS135-2A69JH2BC  DATE: 04/20/19
Flash Type - WINBOND 29EE011 /5U

File Name to Program : test.bin
File Name to Save   : t002.bin

Error Message:
```

5. Type “Y” to begin programming, and press the ENTER key.
6. When the programming is finished, the showing message will appear:
7. Once you see the showing message “Power Off or Reset System”, please restart your system.
8. When you power on the computer again, you will find your old BIOS has already been successfully updated.

To view a complete usage of FLASH utility, please type “awdf flash /?” and press the ENTER key.

Notes About Award Flash Utility

Please note that Award Flash Utility cannot run under **EMM386** or **QEMM**. Thus, when executing the command “awdf flash”, an error message will appear:

“Error Message: Fail — Due to EMM386 or QEMM !”

6

BIOS SETUP

The BIOS ROM has a built-in Setup program that allows users to modify the basic system configuration. This type of information is stored in battery-backed RAM so that it retains the Setup information when the power is turned off.

Entering Setup

Power on the computer and press immediately will allow you to enter Setup. The other way to enter Setup is to power on the computer, when the below message appear briefly at the bottom of the screen during the POST (Power On Self Test), press key or simultaneously press <Ctrl>, <Alt>, and <Esc> keys.

“Press DEL to enter SETUP”

If the message disappears before you respond and you still wish to enter Setup, restart the system to try again by turning it OFF the ON or pressing the “RESET” button on the system case. You may also restart by simultaneously press <Ctrl>, <Alt>, and <Delete> keys. If you do not press the keys at the correct time and the system does not boot, an error message will be displayed and you will again be asked to,

“Press F1 to Continue, DEL To Enter Setup”

6.1 The Main Menu

ROM PCI/ISA BIOS (2A69KH2E) CMOS SETUP UTILITY AWARD SOFTWARE, INC.	
STANDARD CMOS SETUP	CPU SPEED SETTING
BIOS FEATURES SETUP	INTEGRATED PERIPHERALS
CHIPSET FEATURES SETUP	SUPERVISOR PASSWORD
POWER MANAGEMENT SETUP	USER PASSWORD
PNP/PCI CONFIGURATION	IDE HDD AUTO DETECTION
LOAD BIOS DEFAULTS	SAVE & EXIT SETUP
LOAD SETUP DEFAULTS	EXIT WITHOUT SAVING
Esc : Quit	F4 : Select Item
F10 : Save & Exit Setup	(Shift)F2 : Change Color

Standard CMOS Setup

This setup page includes all items in a standard compatible BIOS.

BIOS Features Setup

This setup page includes all items of Award special enhanced features.

Chipset Features Setup

This setup page includes all items of chipset features.

Power Management Setup

This setup page includes all items of Power Management features.

PNP/PCI Configuration Setup

This item specifies the value (in units of PCI bus blocks) of the latency timer for the PCI bus master and the IRQ level for PCI device. Power-on with BIOS defaults

Load BIOS Defaults

BIOS defaults loads the values required by the System for the maximum performance. However, you can change the parameter through each Setup Menu.

Load Setup Defaults

Setup defaults loads the values required by the system for the O.K. performance. However, you can change the parameter through each Setup Menu.

CPU Speed Setting

This setup includes all items of CPU speed features.

Integrated Peripherals

This setup page includes all items of peripheral features.

Supervisor Password

Change, set, or disable supervisor password. It allows you to limit access to the system and Setup, or just to Setup.

User Password

Change, set, or disable user password. It allows you to limit access to the system and Setup, or just to Setup.

IDE HDD Auto Detection

Automatically configure IDE hard disk drive parameters.

Save & Exit Setup

Save CMOS value change to CMOS and exit setup

Exit Without Saving

Abandon all CMOS value changes and exit setup.

6.2 Standard CMOS Setup

```
ROM PCI/ISA BIOS (2A69KH2E)
STANDARD CMOS SETUP
AWARD SOFTWARE, INC.

Date (mm:dd:yy) : Wed, Apr 21 1999
Time (hh:mm:ss) : 15 : 0 : 24

HARD DISKS      TYPE   SIZE  CYLS HEAD PRECOMP LANBZ SECTOR  MODE
-----
Primary Master : AUTO   0      0  0  0      0  0      0  AUTO
Primary Slave  : AUTO   0      0  0  0      0  0      0  AUTO
Secondary Master : AUTO   0      0  0  0      0  0      0  AUTO
Secondary Slave : AUTO   0      0  0  0      0  0      0  AUTO

Drive A : 1.44M, 3.5 in.
Drive B : None

Video : EGA/UGA
Halt On : All Errors

Base Memory : 0K
Extended Memory : 0K
Other Memory : 512K
-----
Total Memory : 512K

ESC : Quit      ↑ ↓ + * : Select Item      PU/PD/+/- : Modify
F1 : Help      (Shift)F2 : Change Color
```

Date

The date format is <day>, <month> <date> <year>. Press <F3> to show the calendar.

Time

The time format is <hour> <minute> <second>. The time is calculated base on the 24-hour military-time clock. For example, 5 p.m. is 17:00:00.

Hard Disks Type

This item identify the types of hard disk drives that has been installed in the computer. There are 46 predefined types and a user definable type.

Press PgUp or PgDn to select a numbered hard disk type or type the number and press <Enter>. Note that the specifications of your drive must match with the drive table. The hard disk will not work properly if you enter improper information for this item. If your hard disk drive type is not matched or listed, you can use Type User to define your own drive type manually.

If you select Type User, related information is asked to be entered to the following items. Enter the information directly from the keyboard and press <Enter>. Those information should be provided in the documentation from your hard disk vendor or the system manufacturer.

The user may also set those items to AUTO to auto configure hard disk drives parameter when system power-on.

If a hard disk drive has not been installed select NONE and press <Enter>.

Drive A type / Drive B type

This item specifies the types of floppy disk drive A or drive B that has been installed in the system.

Video

This item selects the type of adapter used for the primary system monitor that must match your video display card and monitor. Although secondary monitors are supported, you do not have to select the type in Setup.

Halt On

This item determines if the system will stop, when an error is detected during power up.

Memory

This item is display-only. It is automatically detected by POST (Power On Self Test) of the BIOS.

Base Memory

The POST of the BIOS will determine the amount of base (or conventional) memory installed in the system. The value of the base memory is typically 512K for systems with 512K memory installed on the mainboard, or 640K for systems with 640K or more memory installed on the mainboard.

Extended Memory

The BIOS determines how much extended memory is present during the POST. This is the amount of memory located above 1MB in the CPU's memory address map.

6.3 BIOS Features Setup

ROM PCI/ISA BIOS (2A69KH2E) BIOS FEATURES SETUP AWARD SOFTWARE, INC.			
Virus Warning	: Disabled	Video BIOS Shadow	: Enabled
CPU Internal Cache	: Enabled	C8000-CBFFF Shadow	: Disabled
External Cache	: Enabled	CC000-CFFFF Shadow	: Disabled
CPU L2 Cache ECC Checking	: Enabled	D0000-D3FFF Shadow	: Disabled
Quick Power On Self Test	: Enabled	D4000-D7FFF Shadow	: Disabled
Boot Sequence	: A,C,SCSI	D8000-DBFFF Shadow	: Disabled
Swap Floppy Drive	: Disabled	DC000-DEFFF Shadow	: Disabled
Boot Up Floppy Seek	: Enabled		
Boot Up NumLock Status	: On		
Gate A20 Option	: Fast		
Typeomatic Rate Setting	: Disabled		
Typeomatic Rate (Chars/Sec)	: 6		
Typeomatic Delay (Msec)	: 250		
Security Option	: Setup		
PCI/UGA Palette Snoop	: Disabled		
OS Select For DRAM > 64MB	: Non-OS2		
Report No FDD For WIN 95	: No		
		ESC : Quit	↑↓ : Select Item
		F1 : Help	PU/PD/←/→ : Modify
		F5 : Old Values (Shift)	F2 : Color
		F6 : Load BIOS Defaults	
		F7 : Load Setup Defaults	

Virus Warning

When this item is enabled, the Award BIOS will monitor the boot sector and partition table of the hard disk drive for any attempt at modification. If an attempt is made, the BIOS will halt the system and the following error message will appear. Afterwards, if necessary, you will be able to run an anti-virus program to locate and remove the problem before any damage is done.

!WARNING!
Disk boot sector is to be modified
Type "Y" to accept write or "N" to abort write
Award Software, Inc.

CPU Internal Cache

This item enables CPU internal cache to speed up memory access.

External Cache

This item enables CPU secondary cache to speed up memory access.

CPU L2 Cache ECC Checking

When you select Enabled, memory checking is enabled when the external cache contains ECC SRAMs.

Quick Power On Self Test

This item speeds up Power On Self Test (POST) after you power on the computer. If it is set to Enabled, BIOS will shorten or skip some check items during POST.

Boot Sequence

This item determines which drive computer searches first for the disk operating system. Default setting is A, C, SCSI.
BIOS also support system boot from CD-ROM drive or SCSI hard disk drive.

Swap Floppy Drive

When this item enables, the BIOS will swap floppy drive assignments so that Drive A: will function as Drive B: and Drive B: as Drive A:.

Boot Up Floppy Seek

When this item enables, the BIOS will swap floppy drive assignments so that Drive A: will function as Drive B: and Drive B: as Drive A:.

Boot Up NumLock Status

When this option enables, BIOS turns on *Num Lock* when system is powered on.

Gate A20 Option

This entry allows you to select how the gate A20 is handled. The gate A20 is a device used to address memory above 1 MByte. Initially, the gate A20 was handled via a pin on the keyboard. Today, while keyboards still provide this support, it is more common, and much faster, set to Fast for the system chipset to provide support for gate A20.

Typematic Rate Setting

This determines if the typematic rate is to be used. when disabled, continually holding down a key on your keyboard will generate only one instance. In other words, the BIOS will only report that the key is down. When the typematic rate is enabled, the BIOS will report as before, but it will then wait a moment, and, if the key is still down, it will begin the report that the key has been depressed repeatedly. For example, you would use such a feature to accelerate cursor movements with the arrow keys.

Typematic Rate (Chars/Sec)

When the typematic rate is enabled, this selection allows you select the rate at which the keys are accelerated.

Typematic Delay (Msec)

When the typematic rate is enabled, this selection allows you to select the delay between when the key was first depressed and when the acceleration begins

Security Option

This item allows you to limit access to the System and Setup, or just to Setup.
When *System* is selected, the System will not boot and access to Setup will be denied if the correct password is not entered at the prompt.
When *Setup* is selected, the System will boot, but access to Setup will be denied if the correct password is not entered at the prompt.

PCI/VGA Palette Snoop

This item must be set to enabled if there is a MPEG ISA card installed in the system, and disabled if there is no MPEG ISA card installed in the system.

OS Select For DRAM > 64MB

This item allows you to access the memory that over 64 MB in OS/2.

Report No FDD For WIN 95

This item enable for report No FDD for WIN95 if No FDD install.

Video BIOS Shadow

Determines whether video BIOS will be copied to RAM. However, it is optional depending on chipset design. Video Shadow will increase the video speed.

C8000-CBFFF Shadow / DC000-DFFFF Shadow

These categories determine whether option ROMs will be copied to RAM. An example of such option ROM would be support of SCSI Add-on card.

6.4 Chipset Features Setup

ROM PCI/ISA BIOS (2A69KH2E) CHIPSET FEATURES SETUP AWARD SOFTWARE, INC.	
Auto Configuration	: Enabled
EDO DRAM Speed Selection	: 60ns
EDO CASx# MA Wait State	: 1
EDO RASx# Wait State	: 1
SDRAM RAS-to-CAS Delay	: 3
SDRAM RAS Precharge Time	: 3
DRAM Idle Timer	: 8
SDRAM CAS latency Time	: 3
SDRAM Precharge Control	: Disabled
DRAM Data Integrity Mode	: Non ECC
System BIOS Cacheable	: Disabled
Video BIOS Cacheable	: Disabled
Video RAM Cacheable	: Disabled
8 Bit I/O Recovery Time	: 1
16 Bit I/O Recovery Time	: 1
Memory Hole At 15M-16M	: Disabled
Passive Release	: Enabled
Delayed Transaction	: Disabled
AGP Aperture Size (MB)	: 64
ESC	: Quit
F1	: Help
F5	: Old Values
F6	: Load BIOS Defaults
F7	: Load Setup Defaults
↑↓	: Select Item
PG/PD/+/-	: Modify
(Shift)F2	: Color

Auto Configuration

The default setting of the optimal timings for items 3 through 7 for 60ns EDO DRAM modules.

EDO DRAM Speed Selection

This item set the EDO DRAM Read/Write timings that the system uses. When item of "Auto Configuration" is disabled, this item will not show up.

EDO CASx# MA Wait State

The board designer may elect to insert one additional wait state before the assertion of the first CASx# for page hit cycles, thus allowing one additional clock of MA setup time to the CASx# for the leadoff page hit cycle. Do not change from the manufacturer's default unless you are getting memory addressing errors.

EDO RASx# Wait State

The board designer may elect to insert one additional wait state before RASx# is asserted for row misses, thus allowing one additional MAX [13:0] setup time to RASx# assertion. This field applies only if EDO DRAM is installed in the system.

SDRAM RAS-to-CAS Delay

This field lets you control the number of DCLKs between a Row Activate command and a read or write command.

SDRAM RAS Precharge Time

The precharge time is the number of cycles it takes for the RAS to accumulate its charge before DRAM refresh. If insufficient time is allowed, refresh may be incomplete and the DRAM may fail to retain data. This field applies only if synchronous DRAM is installed in the system.

DRAM Idle Timer

This item specifies the number of clocks that the DRAM controller will remain in IDLE state before precharging all pages.

SDRAM CAS Latency Time

When synchronous DRAM is installed, you can control the number of CLKs between when the SDRAMs sample a read command and when the controller samples read data from the SDRAMs. Do not reset this field from the default value specified by the system designer.

SDRAM Precharge Control

When Enabled, all CPU cycles to SDRAM result in an All Banks Precharge Command on the SDRAM interface.

DRAM Data Integrity Mode

This item allows the user to set DRAM data integrity mode to *Non-ECC* or *ECC*. Non-ECC has byte-wide write capability but no provision for protecting data integrity in the DRAM array. ECC allows a detection of single-bit and multiple-bit errors and recovery of single-bit errors.

System BIOS Cacheable

This item allows the user to set whether the system BIOS F000 ~ FFFF areas are cacheable or non-cacheable.

Video BIOS Cacheable

This item allows the user to set whether the video BIOS C000 ~ C7FF areas are cacheable or non-cacheable.

Video RAM Cacheable

This is a new cache technology for the video memory of the processor. It can greatly improve the display speed by caching the display data. You must leave this on the default setting of *Disabled* if your display card cannot support this feature or else your system may not boot.

8 Bit I/O Recovery Time

The recovery time is the length of time, measured in CPU clocks, which the system will delay after the completion of an input/output request. This delay takes place because the CPU is operating so much after than the input/output bus that the CPU must be delayed to allow for the completion of the I/O.

This item allows you to determine the recovery time allowed for 8 bit I/O. Choices are from NA, 1 to 8 CPU clocks.

16-Bit I/O Recovery Time

This item allows you to determine the recovery time allowed for 16 bit I/O. Choices are from NA, 1 to 4 CPU clocks.

Memory Hole At 15M-16M

In order to improve performance, certain space in memory can be reserved for ISA cards. This memory must be mapped into the memory space below 16 MB.

Passive Release

When enabled, the chipset provides a programmable passive release mechanism to meet the required ISA master latencies.

Delayed Transaction

Since the 2.1 revision of the PCI specification requires much tighter controls on target and master latency. PCI cycles to or from ISA typically take longer. When enabled, the chipset provides a programmable delayed completion mechanism to meet the required target latencies.

AGP Aperture Size (MB)

This item allows the user to set memory-mapped, graphics data structures can reside in Graphics Aperture.

6.5 Power Management Setup

ROM PCI/ISA BIOS (2A69KH2E) POWER MANAGEMENT SETUP AWARD SOFTWARE, INC.		
Power Management	: Min Saving	** Reload Global Timer Events **
PM Control by APM	: Yes	IRQ13-7,9-15,1.NMI : Disabled
Video Off Method	: U/H SYNC+Blank	Primary IDE 0 : Disabled
Video Off After	: Standby	Primary IDE 1 : Disabled
MODEM Use IRQ	: 3	Secondary IDE 0 : Disabled
Doze Mode	: Disabled	Secondary IDE 1 : Disabled
Standby Mode	: Disabled	Floppy Disk : Disabled
Suspend Mode	: Disabled	Serial Port : Enabled
HDD Power Down	: Disabled	Parallel Port : Disabled
Throttle Duty Cycle	: 62.5%	Resume by LAN : Disabled
PCI/UGA Act-Monitor	: Disabled	
Soft-Off by PWR-BTIN	: Instant-Off	
CPUFAN Off In Suspend	: Enabled	
PowerOn by Ring	: Disabled	
Power On on PCI card	: Disabled	
Resume by Alarm	: Disabled	
IRQ 8 Break Suspend	: Enabled	
		ESC : Quit F10 : Select Item
		F1 : Help F4/PD/+/ : Modify
		F5 : Old Values (Shift) F2 : Color
		F6 : Load BIOS Defaults
		F7 : Load Setup Defaults

Power Management

This item determines the options of the power management function. *Max Saving* puts the system into power saving mode after a brief period of system inactivity; *Min Saving* is the same as *Max Saving* except the time of the system inactivity period is longer; *Disabled* disables the power saving feature; *User Defined* allows you to set power saving options according to your preference.

PM Control by APM

If this item set to *No*, system BIOS will be ignored and APM calls the power to manage the system.

If this item setup to *Yes*, system BIOS will wait for APM's prompt before it enter any PM mode e.g. *DOZE*, *STANDBY* or *SUSPEND*.

Video Off Method

This item define the video off features - *V/H SYNC + Blank*, *DPMS*, and *Blank Only*. The first option, which is the default setting, blanks the screen and turns off vertical and horizontal scanning; *DPMS* allows the BIOS to control the video display card if it supports the *DPMS* feature; *Blank Screen* only blanks the screen.

Video Off After

This item define when to activate the video off feature for monitor power management. The settings are *N/A*, *Doze*, *Standby* and *Suspend*.

MODEM Use IRQ

This item determines the IRQ in which the MODEM can use.
The choice: 1, 3, 4, 5, 7, 9, 10, 11, *N/A*.

Doze Mode

When enabled and after the set time of system inactivity, the CPU clock will run at slower speed while all other devices still operate at full speed.

Standby Mode

When enabled and after the set time of system inactivity, the fixed disk drive and the video would be shut off while all other devices still operate at full speed.

Suspend Mode

When enabled and after the set time of system inactivity, all devices except the CPU will be shut off.

HDD Power Down

This item defines the continuous HDD idle time before the HDD enters power saving mode (motor off). The options are from 1 min to 15 min and *Disabled*.

Throttle Duty Cycle

This item determines the duty cycle for the clock control thermal throttling mode. The duty cycle indicates the percentage of time while in the thermal throttle mode. The settings between 12.5% and 87.5%.

PCI/VGA Act-Monitor

If this item is set to Enabled, the VGA activity event will be monitored to reload global timer.

Soft-Off by PWR-BTTN

The setting of **Instant-Off** allows the ATX switch to function as a normal system power off button when pressed for less than 4 seconds. The setting of **Delay 4 Sec.** allows the button to have a dual function where to press the button for less than 4 seconds will place the system in suspend mode, and pressing the button for more than 4 seconds will shut place the system off.

CPUFAN OFF In Suspend

This item determine CPU fan status when the system enters suspend mode. The options Enabled and Disabled.

PowerOn by Ring

This item determine the system will resume by activating of modem ring.

Power On on PCI card

This item determine the system will power-on by activity of PCI card which with "PME" signal.

Resume by Alarm

This item determine the system will resume by activity of R.T.C. If enabled this feature and enter resume date and time. When date and time expire, system will power-on itself from power off.

IRQ 8 Break Suspend

You can turn On or Off monitoring of IRQ8 (the Real Time Clock) so it does not awaken the system from Suspend mode.

**** Reload Global Timer Events ****

If any of these items is set to Disabled, that system activity event will not be monitored to reload global timer.

If these items is set to Enabled, that system activity event will be monitored to reload global timer.

These items include IRQ[3-7, 9-15], NMI, Primary IDE0/1, Secondary IDE 0/1, Floppy Disk, Serial Port and Parallel Port.

Resume by LAN (Wake-ON-LAN)

This item determine the system will resume by activity of LAN. If enabled this feature system will power-on itself from power off when the activity of LAN.

Note : MB11/MZ11 support Wake-ON-LAN function with Intel LAN card only.

6.6 PNP/PCI Configuration Setup

ROM PCI/ISA BIOS (2A69KH2E) PNP/PCI CONFIGURATION AWARD SOFTWARE, INC.	
PNP OS Installed : No	PCI IDE IRQ Map To : ISA
Resources Controlled By : Manual	Slot 1 Use IRQ No. : Auto
Reset Configuration Data : Disabled	Slot 2 Use IRQ No. : Auto
IRQ-3 assigned to : PCI/ISA PnP	Slot 3 Use IRQ No. : Auto
IRQ-4 assigned to : PCI/ISA PnP	Used MEM base addr : N/A
IRQ-5 assigned to : PCI/ISA PnP	Assign IRQ For USB : Enabled
IRQ-7 assigned to : PCI/ISA PnP	PCI Latency Timer (CLK): 64
IRQ-9 assigned to : PCI/ISA PnP	MS IRQ Routing Table : Disabled
IRQ-10 assigned to : PCI/ISA PnP	ESC : Quit F10 : Select Item
IRQ-11 assigned to : PCI/ISA PnP	F1 : Help F11/PD/+/< : Modify
IRQ-12 assigned to : PCI/ISA PnP	F5 : Old Values (Shift)F2 : Color
IRQ-14 assigned to : PCI/ISA PnP	F6 : Load BIOS Defaults
IRQ-15 assigned to : PCI/ISA PnP	F7 : Load Setup Defaults
DMA-0 assigned to : PCI/ISA PnP	
DMA-1 assigned to : PCI/ISA PnP	
DMA-3 assigned to : PCI/ISA PnP	
DMA-5 assigned to : PCI/ISA PnP	
DMA-6 assigned to : PCI/ISA PnP	
DMA-7 assigned to : PCI/ISA PnP	

PNP OS Installed

When this item is set to Yes, it will allow the PnP OS (Windows 95) control the system resources except PCI devices and PnP boot devices.
Default setting is *No*.

Resources Controlled By

The Award Plug and Play BIOS has the capability to automatically configure all of the boot and Plug and Play compatible devices. However, this capability means absolutely nothing unless you are using a Plug and Play operating system as Windows 95.

Reset Configuration Data

This item allows you to determine whether to reset the configuration data or not.

IRQ 3/4/5/7/9/10/11/12/14/15, assigned to

These items allow you to determine the IRQ assigned to the ISA bus and is not available for PCI slot. Choices are *Legacy ISA* and *PCI/ISA PnP*.

DMA 0/1/3/5/6/7 assigned to

These items allow you to determine the DMA assigned to the ISA bus and is not available for PCI slot. Choices are *Legacy ISA* and *PCI/ISA PnP*.

PCI IDE IRQ Map to

This items allows you to configure your system to the type of IDE disk controller in use. By default, Setup assumes that your controller is an ISA device rather than a PCI controller.

If you have equipped your system with a PCI controller, changing this allows you to specify which slot has the controller and which PCI interrupt (A, B, C or D) is associated with the connected hard drives.

Remember that this setting refers to the hard disk drive itself, rather than individual partitions. Since each IDE controller supports two separate hard disk drives, you can select the INT# for each. Again, you will note that the primary has a lower interrupt than the secondary as described in "*Slot x Using INT#*" above.

Selecting "*PCI Auto*" allows the system to automatically determine how your IDE disk system is configured.

Slot 1/2/3 Use IRQ No

These items are used to assign system interrupt to each PCI slot automatically or manually.

The choices are 3, 4, 5, 7, 9, 10, 11, 12, 14, 15 and Auto.

Used MEM base addr

This item is used to select a base address for the memory area used by any peripheral that requires high memory.

The choices are *C800*, *CC00*, *D000*, *D400*, *D800*, *DC00* and *N/A*.

Assign IRQ for USB

This item allows the user to assign IRQ to on-board USB controller or not.

Since on-board controller is enabled always, if none of IRQ is assigned to it, there will be a question mark report on system device under windows 95.

PCI Latency Timer (CLK)

The number of clocks programed in the PCI Latency Timer represents the guaranteed time slice allocated to the 440BX/440ZX, after which it must complete the current data transfer phase and surrender the bus as soon as its bus grant is removed.

The PCI Latency Timer is used to guarantee to the PCI agents a minimum amount of the system resource.

The default setting is 64 PCI clocks.

MS IRQ Routing Table

This item allows the user to set BIOS IRQ Routing Table Enabled or Disabled.

6.7 CPU Features Setup

ROM PCI/ISA BIOS (2A69KH2E) CPU FEATURES SETUP AWARD SOFTWARE, INC.	
Auto Detect DIMM/PCI Clk : Disabled	CPU Warning Temperature : Disabled
Spread Spectrum : Disabled	Current System Temp. : XX°C/XXX°F
CPU Host Clock (CPU/PCI) : XXXMHz	Current CPU1 Temperature : XX°C/XXX°F
CPU Clock Ratio : xX.X	Current CPUFAN1 Speed : XXXXRPM
CPU Speed : XXXMHz	Current CPUFAN2 Speed : XXXXRPM
	Current CPUFAN3 Speed : XXXXRPM
	INB(V) : XX.XU IN1(U) : XX.XU
	IN2(U) : XX.XU + 5 U : XX.XU
	+12 U : XX.XU -12 U :-XX.XU
	- 5 U : -XX.XU
	Shutdown Temperature : 60°C/140°F
ESC : Quit F10 : Select Item	
F1 : Help PU/PD/+/- : Modify	
F5 : Old Values (Shift) F2 : Color	
F6 : Load BIOS Defaults	
F7 : Load Setup Defaults	

Auto Detect DIMM/PCI Clk

Enabling this item allows system auto detect and close clock signal to empty DIMM/PCI slot to reduce EMI.

Spread Spectrum

This item allows the user to enable Spread Spectrum Modulated to reduce the EMI.

CPU Host Clock

This item allows you to Soft-Configure the CPU Host Bus Clock (external bus frequency) in BIOS. Select the proper value according to the specification marked on your CPU. A valid CPU Host Clock may range from 50MHz to 83MHz when a 66MHz-based PPGA Celeron processor is used or from 100MHz, 103MHz when a 100MHz-based PPGA Celeron processor is used.

CPU Clock Ratio

This item allows the user to adjust CPU Host Clock/Internal Clock ratio. The user may adjust CPU Clock Ratio from x2 to x8 in 0.5 increments.

CPU Speed

The field is read-only. It displays the CPU speed when CPU Host Clock and CPU Clock Ratio have been whether soft-configured in BIOS Chipset Features menu or hard-configured by setting the appropriate jumpers JP2 and JP14 on the mainboard.

The CPU speed (operating frequency) is computed as the product of CPU Host Clock multiplied by CPU Clock Ratio.

(Listed items will show up when optional hardware monitor present)

CPU Warning Temperature

Since the mainboard support CPU temperature monitoring and overhear alert. This item allows the user to set the threshold of CPU warning temperature. When CPU temperature over the threshold, system will slow down clock to prevent CPU damage.

Current System Temperature

Since the mainboard support System temperature monitoring and overheat alert. This item indicate the current main board temperature.

Current CPU1 Temperature

Since the mainboard support CPU temperature monitoring and overheat alert. This item indicate the current Processor temperature.

Current CPUFAN1/2/3 Speed

The mainboard can detect three fans rotation speed for CPU cooler and system.

IN0(V) ~ IN2(V), +5V ~ -5V, +12V ~ -12V

The mainboard support CPU and mainboard voltages monitoring. The onboard hardware monitor is able to detect the voltages output of the voltage regulators and power supply.

Shutdown Temperature

Select the combination of lower and upper limits for the system shutdown temperature, if your computer contains an environmental monitoring system. If the temperature extends beyond either limit, the system shuts down.

6.8 Integrated Peripherals

ROM PCI/ISA BIOS (2A69KNZE) INTEGRATED PERIPHERALS AWARD SOFTWARE, INC.			
IDE HDD Block Mode	: Enabled	Onboard Serial Port 2	: Auto
IDE Primary Master PIO	: Auto	UART Mode Select	: Standard
IDE Primary Slave PIO	: Auto	RxD , TxD Active	: Hi,Lo
IDE Secondary Master PIO	: Auto	IR Transmittiion delay	: Enabled
IDE Secondary Slave PIO	: Auto	Onboard Parallel Port	: 378/IRQ7
IDE Primary Master UDMA	: Auto	Parallel Port Mode	: SPP
IDE Primary Slave UDMA	: Auto	ECP Mode Use DMA	: 3
IDE Secondary Master UDMA	: Auto	EPP Mode Select	: EPP1.9
IDE Secondary Slave UDMA	: Auto		
On-Chip Primary PCI IDE	: Enabled		
On-Chip Secondary PCI IDE	: Enabled		
USB Keyboard Support	: Disabled		
Init Display First	: PCI Slot		
POWER ON Function	: BUTTON ON		
KB Power ON Password	: Enter	ESC : Quit	F10 : Select Item
Hot Key Power ON	: Ctrl-F1	F1 : Help	PU/PD/←/→ : Modify
KBC Input clock	: 8 MHz	F5 : Old Values (Shift)F2 : Color	
Onboard FDC Controller	: Enabled	F6 : Load BIOS Defaults	
Onboard Serial Port 1	: Auto	F7 : Load Setup Defaults	

IDE HDD Block Mode

This item is used to set IDE HDD Block Mode. If your IDE Hard Disk supports block mode, then you can enable this function to speed up the HDD access time. If not, please disable this function to avoid HDD access error.

IDE Primary Master PIO

In this items, there are five modes defined in manual mode and one automatic mode. There are 0, 1, 2, 3, 4, and *AUTO* is the default settings for on board Primary Master PIO timing.

IDE Primary Slave PIO

In this items, there are five modes defined in manual mode and one automatic mode. There are 0, 1, 2, 3, 4, and *AUTO* is the default settings for on board Primary Slave PIO timing.

IDE Secondary Master PIO

In this items, there are five modes defined in manual mode and one automatic mode. There are 0, 1, 2, 3, 4, and *AUTO* is the default settings for on board Secondary Master PIO timing.

IDE Secondary Slave PIO

In this items, there are five modes defined in manual mode and one automatic mode. There are 0, 1, 2, 3, 4, and *AUTO* is the default settings for on board Secondary Slave PIO timing.

IDE Primary Master UDMA

On this mainboard, Intel PIIX4 improves IDE transfer rate using Bus Master UltraDMA/33 IDE which can handle data transfer up to 33MB/sec. The options are *Disabled, Enabled and Auto*, *Auto* is the default settings for on board Primary Master *UltraDMA33*.

Note : Your hard drive must also support UDMA for this feature to work.

IDE Primary Slave UDMA

On this mainboard, Intel PIIX4 improves IDE transfer rate using Bus Master UltraDMA/33 IDE which can handle data transfer up to 33MB/sec. The options are *Disabled, Enabled and Auto*, *Auto* is the default settings for on board Primary Slave *UltraDMA33*.

Note : Your hard drive must also support UDMA for this feature to work.

IDE Secondary Master UDMA

On this mainboard, Intel PIIX4 improves IDE transfer rate using Bus Master UltraDMA/33 IDE which can handle data transfer up to 33MB/sec. The options are *Disabled, Enabled and Auto*, *Auto* is the default settings for on board Secondary Master *UltraDMA33*.

Note : Your hard drive must also support UDMA for this feature to work.

IDE Secondary Slave UDMA

On this mainboard, Intel PIIX4 improves IDE transfer rate using Bus Master UltraDMA/33 IDE which can handle data transfer up to 33MB/sec. The options are *Disabled, Enabled and Auto*, *Auto* is the default settings for on board Secondary Slave *UltraDMA33*.

Note : Your hard drive must also support UDMA for this feature to work.

On-Chip Primary PCI IDE

As stated above, your system includes two built-in IDE controllers, both of which operate on the PCI bus. This setup item allows you either to enable or disable the primary controller. You might choose to disable the controller if you were to add a higher performance or specialized controller.

On-Chip Secondary PCI IDE

As above for the Primary controller, this setup item you either to enable or disable the secondary controller. You might choose to disable the controller if you were to add a higher performance or specialized controller

USB Keyboard Support

This item is used to defined USB Keyboard is *Enabled* or *Disabled*.

Init Display First

This item is used to determine initial device when system power on. The options are *PCI* and *AGP*.

POWER ON Function

This item is used to define Keyboard & PS/2 mouse power-on function enabled or disabled. The options are **Button Only**, **HOT-Key** and **PS/2 Mouse**.
Button Only - Only soft-on/off button on the front panel is available.

KB Power ON Password

This item set the keyboard power-on password. When using keyboard to power on , just Enter the password.

Hot Key Power ON

Power-on by soft-on/off button and keyboard are available. The user may set power-on hot-key from <Ctrl><F1> to <Ctrl><F12>.

KBC input clock

This item to set the input clock to onboard keyboard controller. The options are 8MHz, 12MHz and 16MHz.

Onboard FDC Controller

This item specifies onboard floppy disk drive controller. This setting allows you to connect your floppy disk drives to the onboard floppy connector. Choose the "*Disabled*" settings if you have a separate control card.

Onboard Serial Port 1

This item is used to define onboard serial port 1 to *3F8/IRQ4*, *2F8/IRQ3*, *3E8/IRQ4*, *2E8/IRQ3*, *Auto* or *Disabled*.

Onboard Serial Port 2

This item is used to define onboard serial port 2 to *3F8/IRQ4*, *2F8/IRQ3*, *3E8/IRQ4*, *2E8/IRQ3*, *Auto* or *Disabled*.

UART Mode Select

The main board support IrDA(HPSIR) and Amplitudes Shift Keyed IR(ASKIR) infrared through COM 2 port. This item specifies onboard Infra Red mode to *IrDA 1.0*, *ASKIR*, *MIR 0.57M*, *MIR 1.15M*, *FIR* or *Standard (Disabled)*.
Note : FIR is not available currently.

RxD , TxD Active

This item specifies the Active level for RxD & TxD signal.

IR Transmission delay

This item enable/disable the delay of the IR state change from Rx to Tx mode or Tx to Rx mode.

Onboard Parallel Port

This item specifies onboard parallel port address to *378H*, *278H*, *3BCH* or *Disabled*.

Parallel Port Mode

This item specifies onboard parallel port mode. The options are *SPP* (Standard Parallel Port), *EPP* (Enhanced Parallel Port), *ECP* (Extended Capabilities Port), and *EPP+ECP*.

ECP Mode Use DMA

This item specifies *DMA* (Direct Memory Access) channel when ECP device is in use. The options are *DMA 1* and *DMA 3*. This item will not show up when SPP and EPP printer mode is selected.

EPP Mode Select

This item select the EPP Mode, EPP 1.9 or EPP 1.7.

6.9 Password Setting

This section describes the two access modes that can be set using the options found on the Supervisor Password and User Password.

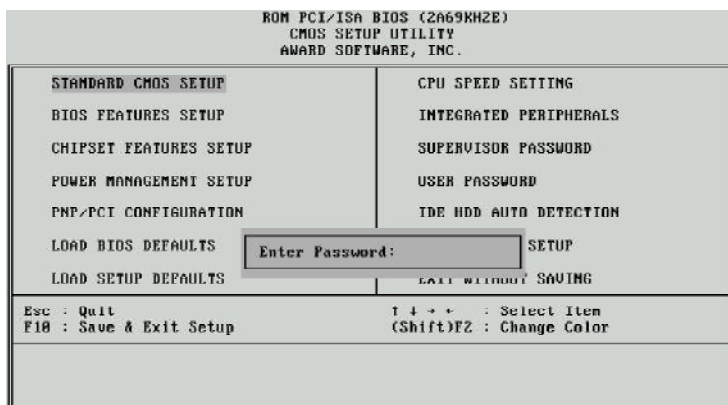

Supervisor Password and User Password

The options on the Password screen menu make it possible to restrict access to the Setup program by enabling you to set passwords for two different access modes: Supervisor mode and User mode.

In general, Supervisor mode has full access to the Setup options, whereas User mode has restricted access to the options. By setting separate Supervisor and User password, a system supervisor can limit who can change critical Setup values.

Enter Password

Type the password, up to eight characters, and press <Enter>. The password typed now will clear any previously entered password from CMOS memory. You will be asked to confirm the password. Type the password again and press <Enter>. You may also press <Esc> to abort the selection and not enter a password.

To disable password, just press <Enter> when you are prompted to enter password. A message will confirm the password being disabled. Once the password is disabled, the system will boot and you can enter Setup freely.

Password Disable

If you select System at Security Option of BIOS Features Setup Menu, you will be prompted for the password every time the system is rebooted or any time you try to enter Setup. If you select Setup at Security Option of BIOS Features Setup Menu, you will be prompted only when you try to enter Setup.

Warning : Retain a record of your password in a safe place. If you forget the password, the only way to access the system is to clear CMOS memory, please refer to page 11 "Clear CMOS".

7

Onboard ATi AGP VGA

General Features

- ❑ Supports AGP 1.0 compliant configuration setting.
- ❑ Triple 8-bit palette DAC with gamma correction for true WYSIWYG color. Pixel rates up to 230MHz
- ❑ Flexible graphics memory configurations: 4MB or 8MB SDRAM.
- ❑ DDC1 and DDC2B+ for Plug-and-Play monitors.
- ❑ Power management with full VESA DPMS and EPA Energy Star compliance.
- ❑ Hardware acceleration of Bitblt, Line Draw, Polygon / Rectangle Fill, Bit Masking, Monochrome Expansion, Panning/Scrolling, Scissoring, full ROP support and h/w cursor.
- ❑ Game acceleration : Double Buffering, Virtual Sprites, Transparent Blit, Masked Blit and Context Chaining.
- ❑ Acceleration in 8/16/24/32 bpp modes.
- ❑ Integrated 1 million triangles set-up engine reduces CPU and bus bandwidth requirements and dramatically improves performance of small 3D primitives
- ❑ 4K on-chip texture cache dramatically improves large triangle performance.
- ❑ Complete 3D primitive support: points, lines triangles, lists, strips and quadrilaterals and BLTs with Z compare.
- ❑ Full support for Direct3D texture lighting.
- ❑ Special effects such as complete alpha blending, fog, video textures, texture lighting, reflection, shadows, spotlights, LOD biasing and texture morphing.
- ❑ Dithering support in 16bpp for near 24bpp quality in less memory.
- ❑ Edge anti-aliasing.

Drivers Overview

To make use of the advance features of ATi Rage Pro AGP VGA Controller, extended graphics modes are bundled on the attached CD-ROM, the following multi-language drivers are currently supported:

MicroSoft Windows 95/98

MicroSoft Windows NT Ver. 4.0

Windows 95/98 Drivers

CD AutoRun Setup

The AutoRun setup feature can run with CD. This utility will enable you to install drivers for Windows 95/98. As the CD is inserted (assuming the auto-insertion feature is enabled under your Windows operating system. Otherwise, double-click the My Computer icon on your Windows Desktop, then Right-click on your CD-ROM drive icon to explore the directory and click on AutoRun.) the **Shuttle Mainboard Software Setup** window will appear on your screen.

1. Select using your pointing device (e.g. mouse) on the “**Install (ATI) Display Adaptor Driver**” bar.

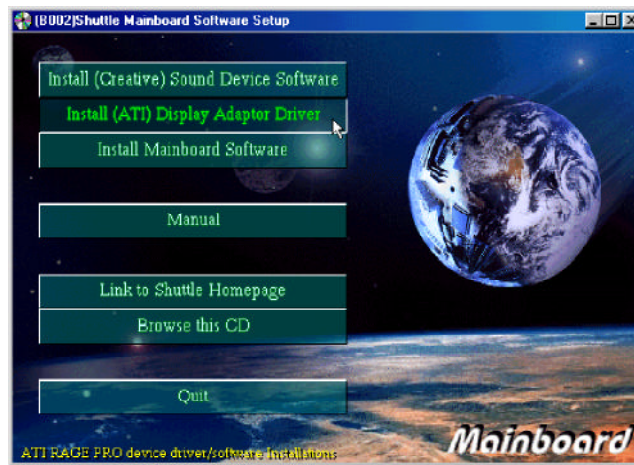

2. Then “**Driver Setup**” windows will appear on your screen. Click on the “**Install ATI Rage Pro Driver**” bar.

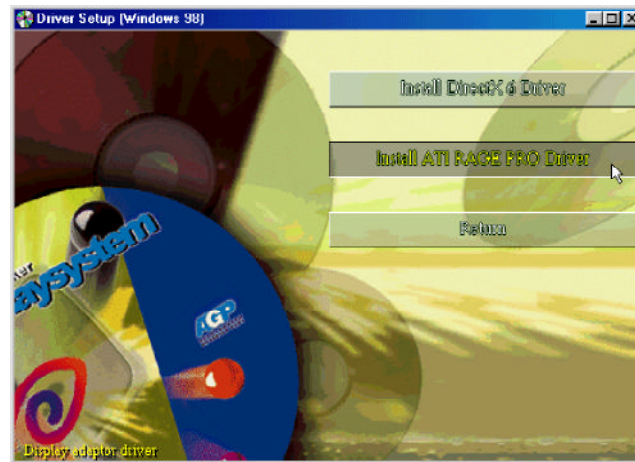

3. Once you made your selection, a Setup window which automatically runs the installation.
4. When the files are done copying make sure you **reboot** the system to insure that the files are installed correctly.

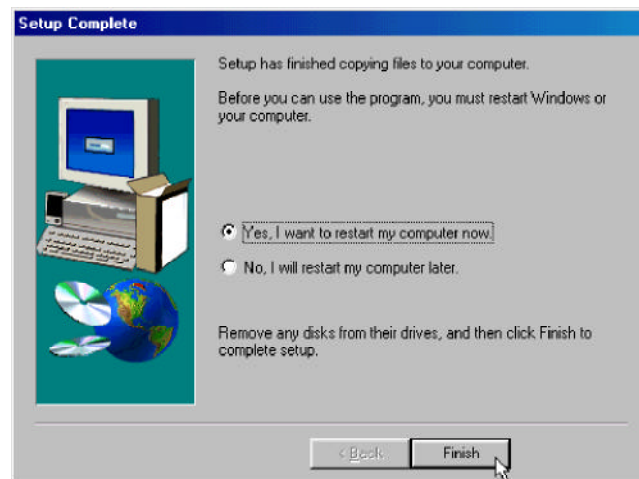

There are three additional tabs "ATi Display", "ATi Adjustment" and "ATi Color" may be added on Display Properties window.

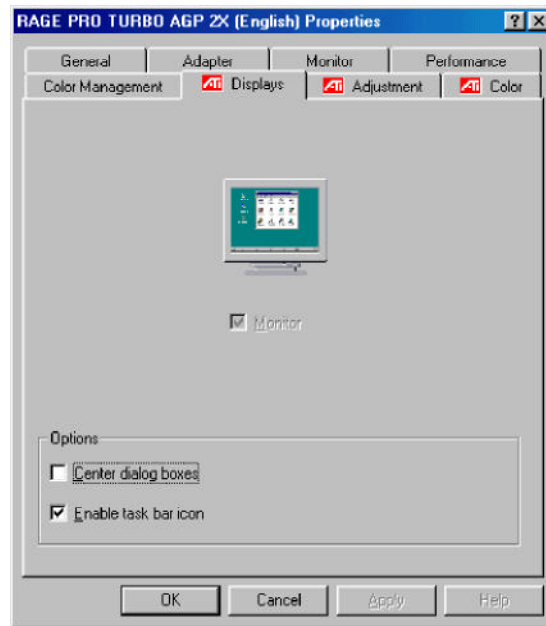

Changing Display Mode

1. Click the right button on the mouse then select the Properties item, **Display Properties** Screen will show up, then click on the Setting tab.
2. On **Display Modes** item and you may select desired resolution by changing **Screen area** pointer and desired color by changing **Color** value.
3. After completing selection, select **OK** or **Apply** to complete the whole setting.

Windows NT4.0 Driver

CD AutoRun Setup

The AutoRun setup feature can run with CD. This utility will enable you to install drivers for Windows NT4.0. As the CD is inserted (assuming the auto-insertion feature is enabled under your Windows operating system. Otherwise, double-click the My Computer icon on your Windows Desktop, then Right-click on your CD-ROM drive icon to explore the directory and click on AutoRun) the **Shuttle Mainboard Software Setup** window will appear on your screen.

1. Select using your pointing device (e.g. mouse) on the “**Install (ATi) Display Adaptor Driver**” bar.



2. Then “**Driver Setup**” windows will appear on your screen. Click on the “**Install ATi Rage Pro Driver**” bar.



3. Once you made your selection, a Setup Note window will display to ask you close other applications and install Windows NT **Service Pack 3** or latest version before you install ATi Rage Pro AGP VGA Windows NT4.0 driver. If you want to continue, click on the **OK** button.

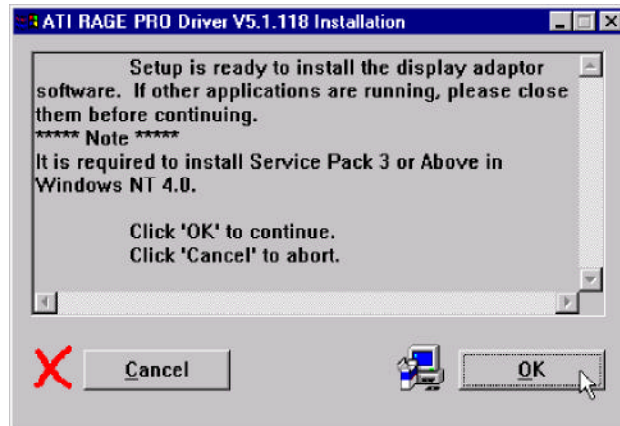

4. When you made your selection, setup program automatically runs the installation.
5. Once the files are done copying, make sure you **reboot** the system to insure that the files are installed correctly.

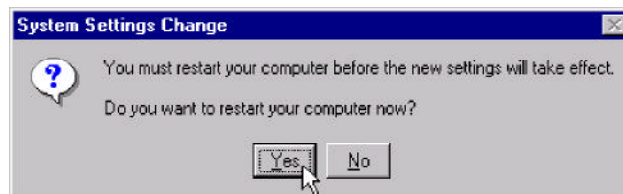

Changing Display Mode

1. Click the right button on the mouse then select the **Properties** item, **Display Properties** Screen will show up.
2. Click on the **Setting** tab.
3. On Display Modes item and you may select desired resolution by changing **Desktop area** pointer, desired color by changing **Color palette** value, desired font size by changing **Font size**, and desired refresh rate by changing **Refresh rate**.
4. After completing selection, Windows NT will ask for display testing for new display mode, click on the **TEST** button to perform display mode test and then select **OK** or **Apply** to complete the whole setting

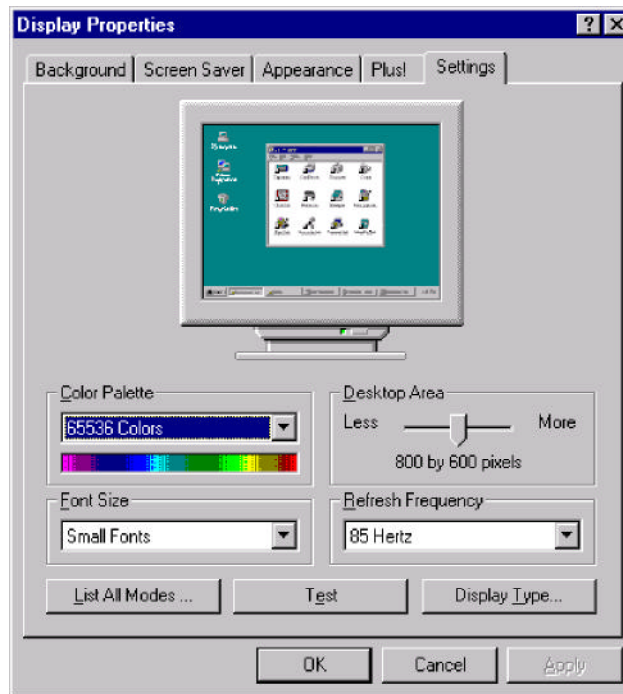

8

Onboard Creative 3D Audio

Introduce

CREATIVE ES1373 Sound Blaster AudioPCI™ 64V

The On-board audio controller is the new Creative AC97 digital controller which provides the next generation of audio performance to the PC market. The ES1373 is available in a 5.0 V PCI bus compatible device that enables the Creative/ENSONIQ Wavetable synthesis PCI solution.

The ES1373 chip includes a complete audio recording and playback system. The ES1373 interfaces to the PCI bus and to AC97, an industry standard CODEC/mixer. This solution is sound Blaster PCI compatible utilizing a patented method of Sound Blaster emulation from Ensoniq. In addition, it is compliant to AC97 interface, Microsoft PC97 and PC98, and Multimedia PC Level II and III specifications.

The ES1373 provides 64 voices polyphony for wavetable audio, sound effects such as reverb, chorus, bass, and treble. As a result, the produced music is more complete and closer to the actual sound. What's more, the ES1373 supports the 3D Positional Audio algorithm from Ensoniq. This 3D Positional Audio implementation also supports the Aureal A3D API for 3D Positional Audio. This allows applications written to this API to run on the ES1373.

The ES1373 support Microsoft DirectSound, DirectSound 3D and DirectMusic. All of these implementations are accelerated through the drivers from Ensoniq. This provides better overall performance for the system and the audio quality.

General Specifications

Wavetable Synthesis

- Creative synthesis engine
- Digital effects engine for reverb and chorus
- 64-voice polyphony and multi-timbral capability
- 16 MIDI channels, 128 GM and GS compatible instruments and 10 drum kits
- MT-32 compatible instrument set
- 2MB, 4MB and 8MB sample sets included

3D Audio Technology

- Support for Microsoft DirectSound
- Localized 3D Sound technology expands the spaciousness of sounds in the traditional two speaker system
- Multi-Algorithm reverb and chorus

Memory Subsystem

- Utilizes system RAM for wavetable samples
- User-configurable for 2MB, 4MB or 8MB

CD-Quality, 16-Bit Stereo Digital Audio

- 8-bit and 16-bit , mono and stereo recording and playback
- User-selectable sample rates from 5 kHz to 48 kHz
- Full Duplex support enables simultaneous record and playback for internet communications software

MIDI Interface / Joystick Port

- Built-in 15-pin MIDI interface (cable available separately)
- Compatible with Sound Blaster and MPU-401 UART modes
- IBM-compatible 15-pin joystick port with analog support

Compatible with the Following Standards

- General MIDI
- Plug and Play
- Sound Blaster PCI

AudioPCI Mixer

- 6 Channel Mixer control for access to CD/Auxiliary, Microphone/Line, Music Synthesizer and Digital Audio
- Spatial audio control for Digital Audio and Music Synthesizer
- Reverb and Chorus control for Music Synthesizer

Install Creative ES1373 Windows 95/98 Driver

This guide describes the procedures for installing the onboard Creative ES1373 device driver software for Windows 95/98. The following procedures will be covered in each section:

Installing the Creative ES1373 device Driver Software in Windows 95/98

Verifying the Creative ES1373 device driver installation

In order to properly install the ES1373 device driver to your computer, follow in order the sections contained in this guide.

1. Insert the installation CD into the CD-ROM driver.
2. If autorun is enabled on your system, the “**Shuttle Mainboard Software Setup**” will appear on your screen. Otherwise, double-click the My Computer icon on your Windows Desktop, then Right-click on your CD-ROM drive icon to explore the directory and click on **AutoRun**.
3. Select the “**Install (Creative) Sound Device Software**” button.



- Once you made your selection, "Sound Blaster AudioPCI 64V" windows appear, click on **Install** button, install wizard will guiding you run the installation.



- When the files are done copying, make sure you **reboot** the system to insure that the files are installed correctly.

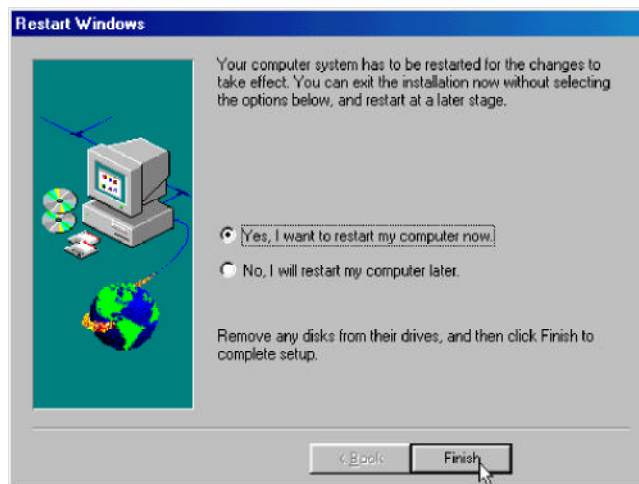

Verifying the Creative ES1373 Device Driver Installation

This section explains how to verify if the ES1373 device driver and software were installed successfully. To see if the ES1373 device driver has been installed successfully, complete the following steps:

1. Click the **Start** button on the Windows taskbar.
2. Highlight **Settings** and click on the **Control Panel** icon.
3. The Control Panel now appears. Double-click the **System** icon.
4. The System Properties window now appears. Click on the **Device Manager** tab as shown in figure below. The Device Manager page now appears as shown.
5. In the hierarchical directory structure illustrated above, double-click on Sound, video and game controllers and verify that ES1373 Device Manager is listed as shown.

Creative Gameport Joystick
SB AudioPCI 64V Legacy Device
Sound Blaster AudioPCI 64V

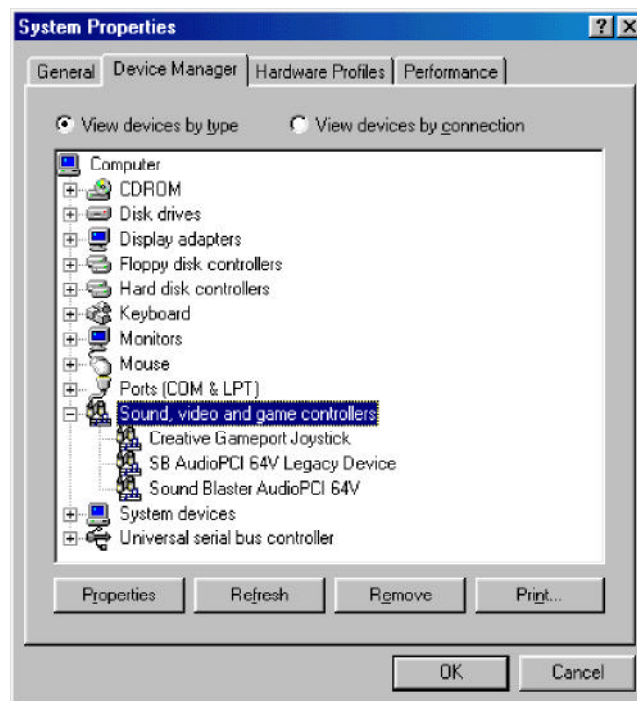

Install Creative ES1373 Windows NT4.0 Driver

This guide describes the necessary procedures for installing the ES1373 device driver software for Windows NT 4.0. The following procedures will Install the ES1373 Device Driver Software. In order to properly install the device driver to your computer, follow in order the sections contained in this guide.

1. Insert the installation CD into the CD-ROM driver.
2. If AutoRun is enabled on your system, the “**Shuttle Mainboard Software Setup**” will appear on your screen. Otherwise, double-click the My Computer icon on your Windows Desktop, then Right-click on your CD-ROM drive icon to explore the directory and click on **AutoRun**.
3. Select the “**Install (Creative) Sound Device Software**” button.



- Once you made your selection, "Sound Blaster AudioPCI 64V" windows appear, click on **Install** button, install wizard will guiding you run the installation.



- When the files are done copying, make sure you **reboot** the system to insure that the files are installed correctly..

