



User's Manual

VIA P4M266A mainboard
for Intel Socket 478 processor

TRADEMARK

All products and company names are trademarks or registered trademarks of their respective holders.

These specifications are subject to change without notice.

*Manual Revision 1.0
July 30, 2003*

DISCLAIMER OF WARRANTIES:

THERE ARE NO WARRANTIES WHICH EXTEND BEYOND THE DESCRIPTION ON THE FACE OF THE MANUFACTURER LIMITED WARRANTY. THE MANUFACTURER EXPRESSLY EXCLUDES ALL OTHER WARRANTIES, EXPRESS OR IMPLIED, REGARDING ITS PRODUCTS; INCLUDING ANY IMPLIED WARRANTIES OF MERCHANTABILITY, FITNESS FOR A PARTICULAR PURPOSE OR NONINFRINGEMENT. THIS DISCLAIMER OF WARRANTIES SHALL APPLY TO THE EXTENT ALLOWED UNDER LOCAL LAWS IN THE COUNTRY PURCHASED IN WHICH LOCAL LAWS DO NOT ALLOW OR LIMIT THE EXCLUSION OF THE IMPLIED WARRANTIES.

Table of Contents

Page

Section 1

Introduction

Package Contents	1-1
Intel Pentium 4 Processors	1-2
Accelerated Graphics Port	1-2
Ultra ATA66/100/133	1-2
Hardware Monitoring	1-3
LAN (Optional)	1-3
Mainboard Form-Factor	1-4
I/O Shield Connector	1-5
Power-On/Off (Remote)	1-5
System Block Diagram	1-6

Section 2

Features

Mainboard Features	2-1
--------------------------	-----

Section 3

Installation

Mainboard Layout	3-2
------------------------	-----

Easy Installation Procedure

CPU Installation	3-3
Jumper Settings	3-5
System Memory Configuration	3-6
Expansion slots	3-8
Device Connectors	3-10
External Modem Ring-in Power ON and Keyboard Power ON Function (KBPO)	3-15
STR (Suspend To RAM) Function	3-16
Supports AGP Card 3.3V Protection	3-17

	<i>Page</i>
<i>Section 4</i>	<i>Award BIOS Setup</i>
	Main Menu 4-1
	Standard CMOS Setup 4-2
	Advanced BIOS Features 4-3
	Advanced Chipset Features 4-7
	Integrated Peripherals 4-12
	Power Management Setup 4-17
	PNP/PCI Configuration Setup 4-21
	PC Health Status 4-23
	Power BIOS Features 4-24
	Defaults Menu 4-26
	Supervisor/User Password Setting 4-27
	Exit Selecting 4-28
<i>Section 5</i>	<i>Driver Installation</i>
	Easy Driver Installation 5-1
	C-Media Audio Configuration Brief Guide 5-2
<i>Appendix</i>	<i>Appendix A</i>
	Update Your System BIOS A-1
	<i>Appendix B</i>
	EEPROM BIOS Remover B-1
	<i>Appendix C</i>
	GHOST 7 Quick User's Guide (Optional) C-1

Section 1 INTRODUCTION

Package Contents

Contents

- A. Mainboard
- B. User's manual
- C. Floppy drive cable
- D. HDD drive cable
- E. CD or diskette (drivers and utilities)
- F. Game port cable
- G. I/O Shield

Optional Items

- H. Extra USB2.0 port cable
- I. S/PDIF Module

If you need the other optional item, please contact your dealer for assistance.

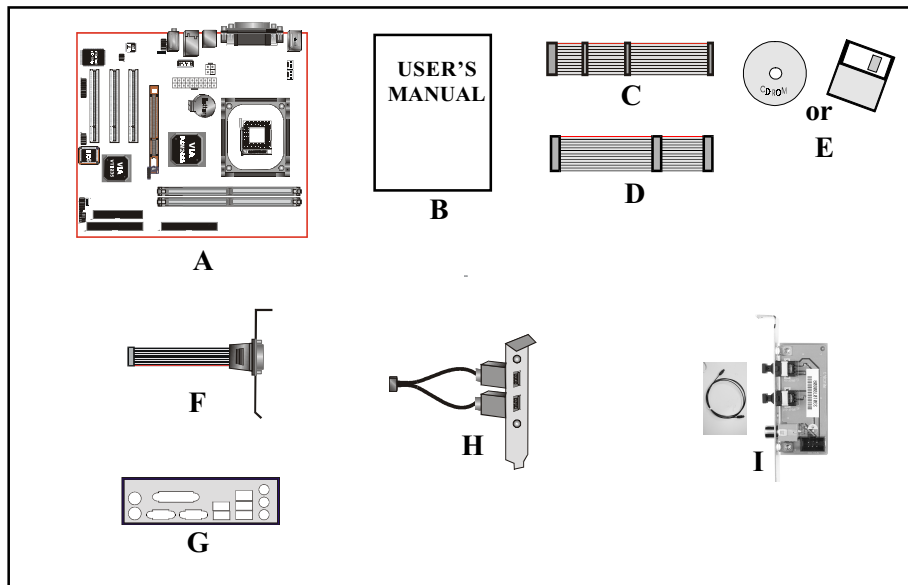

Introduction

Intel® Pentium® 4 processors

The Intel Pentium 4 processor, Intel's most advanced, most powerful processor for desktop PCs and entry-level workstations, is based on Intel NetBurst™ microarchitecture. The Pentium 4 processor is designed to deliver performance across applications and usages where end-users can truly appreciate and experience the performance. These applications include Internet audio and streaming video, image processing, video content creation, speech, 3D, CAD, games, multimedia, and multi-tasking user environments. The Pentium 4 processor delivers this world-class performance for consumer enthusiasts and business professional desktop PC users as well as for entry-level workstation users.

Intel adds support for Hyper-Threading Technology to the Pentium 4 processor family. HT Technology allows a single, physical Pentium 4 processor to function as two logical processor for next generation multi threaded application.

For more information about all the new features Pentium 4 deliver, check out the Intel website at <http://www.intel.com>

Accelerated Graphics Port (AGP)

The AGP slot on the board is compliant with the new AGP 2.0 specification. This new specification enhances the functionality of the original AGP specification by allowing 4X data transfers (4 data samples per clock) resulting in maximum bandwidth of 1GB/s. In addition, it defines 1.5 volt power supply operation. Complying with this specification, this board supports external AGP-4X cards with Fast Write Transactions. Only 1.5V AGP cards are supported.

Ultra ATA/66/100/133

This mainboard provides two independent ATA 133 IDE controllers, supporting standard programmable input/output (PIO) and Direct Memory Access (DMA) mode operations, as well as UltraDMA-133/100/66/33 standards for a maximum data transfer rate of 133MB/sec per channel.

Hardware Monitoring

Hardware monitoring enables you to monitor various aspects of the system operation and status. The features include CPU temperature, voltage and fan speed in RPMs.

LAN (Optional)

This mainboard is optionally mounted with a LAN chipset. It allows the mainboard to connect to a local area network by means of a network hub.

Introduction

Mainboard Form-Factor

This board is designed with ATX form factor - the latest industry standard for chassis design. The ATX form factor is essentially a Baby-AT baseboard rotated 90 degrees within the chassis enclosure and a new mounting configuration for the power supply. With these changes the processor is relocated away from the expansion slots, allowing them all to hold full length add-in cards. ATX defines a double height aperture to the rear of the chassis which can be used to host a wide range of onboard I/O. Only the size and position of this aperture is defined, allowing PC manufacturers to add new I/O features (e.g.; TV input, TV output, joystick, modem, LAN, audio, etc.) to systems. This will help systems integrators differentiate their products in the marketplace, and better meet your needs.

- By integrating more I/O down onto the board and better positioning the hard drive and floppy connectors material cost of cables and add-in cards is reduced.
- By reducing the number of cables and components in the system, manufacturing time and inventory holding costs are reduced and reliability will increase.
- By using an optimized power supply, it's possible to reduce cooling costs and lower acoustical noise. An ATX power supply, which has a side-mounted fan, allows direct cooling of the processor and add-in cards making a secondary fan or active heatsink unnecessary in most system applications.

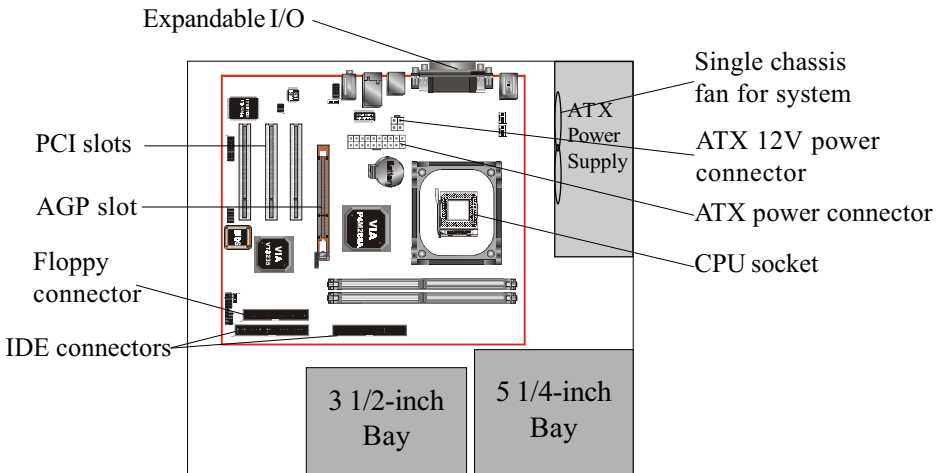

Figure 2: Summary of ATX chassis features

I/O Shield Connector

The board is equipped with an I/O back panel (Figure 3). Ensure that your computer case has the appropriate I/O cutout.

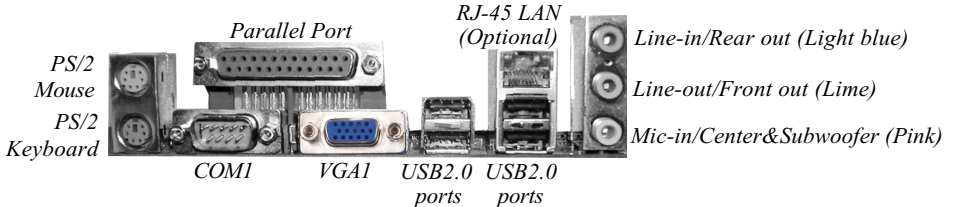

Figure 3: I/O ports

Power-On/Off (Remote)

This board has a 20-pin ATX and a 4-pin ATX12V power supply connector (Figure 4). For power supplies that support the **Remote On/Off** feature, this should be connected to the mainboard front panel PW_ON connector for the computer power On/Off button.

The board has been designed with "Soft Off" function. You can turn off the system in two ways: by pressing the front panel power On/Off button or using the "Soft Off" function (incorporated in the mainboard's onboard circuit controller) that can be controlled by an operating system such as Windows®XP/ME/2000/98.

Note: For maintaining the DDR SDRAM power during STR (ACPI S3) function, it is strongly recommended to use power supplies that have a +5VSB current of (> =) 2A. Please check the 5VSB's specification that has been printed on the power supply's outer case.

Note: The board requires a minimum of 250 Watt power supply to operate. Your system configuration (amount of memory, add-in cards, peripherals, etc.) may exceed this minimum power requirement. To ensure that adequate power is provided, use a 300 Watt (or higher) power supply.

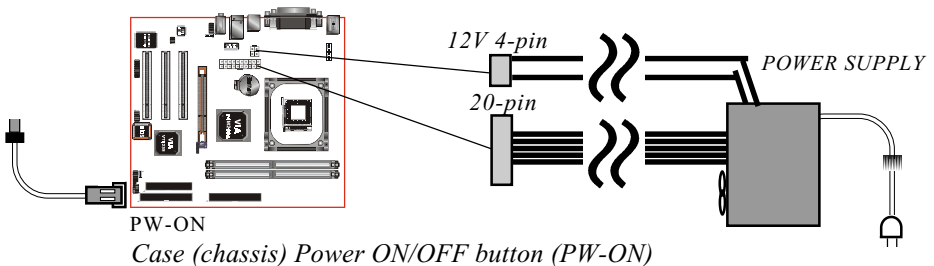

Figure 4: Simple ATX power ON/OFF controller

Introduction

System Block Diagram

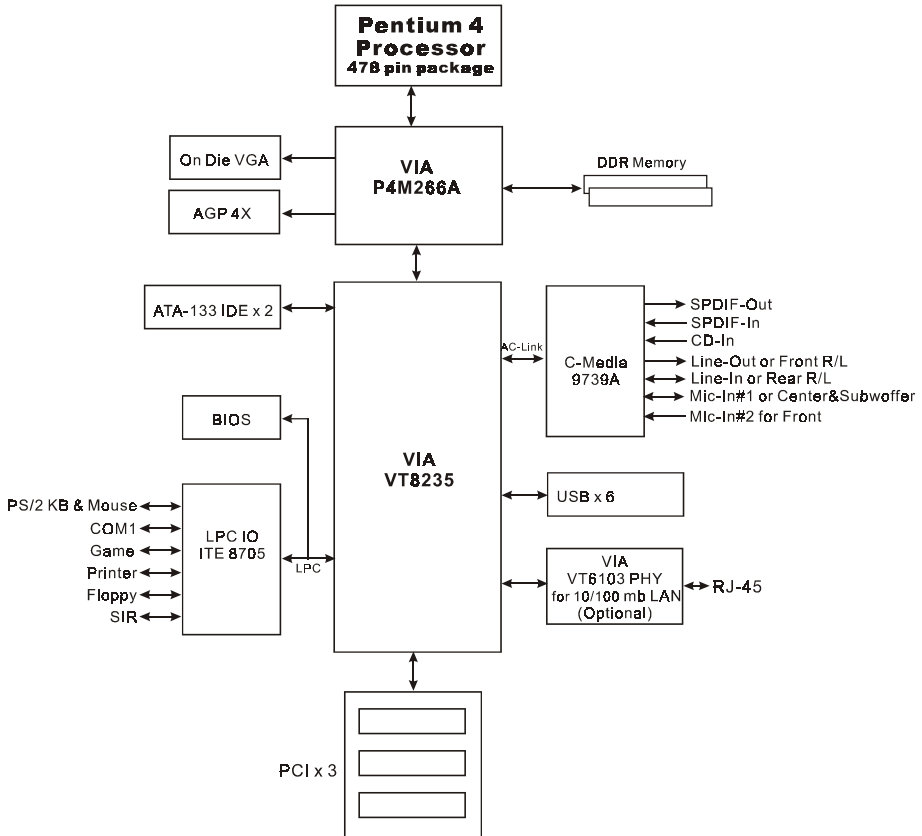

Figure 5: System Block Diagram

Mainboard Features

● **Processor**

- ◆ Socket 478 Intel® Pentium® 4 processor with 533MHz front side bus up to 3.0+GHz
- ◆ Socket 478 Intel® Celeron processor with 400MHz front side bus up to 2.4 GHz

● **Chipset**

- ◆ VIA P4M266A AGPset : VIA P4M266A + VT8235
 - Built-in VIA ProSavage 8 Graphics core

● **Main Memory**

- ◆ **Two** 184-pin DDR DIMM sockets for 64-bit, Unbuffered, Single/Double-side and Non-ECC DDR-200/266 DIMMs
- ◆ Supports up to **2GB** memory size

● **BIOS**

- ◆ Flash EEPROM with Award BIOS
 - ACPI v2.0 compliant
 - S3 (Suspend to DRAM) sleep-state support
 - SMBIOS (System Management BIOS) v2.2 compliant
 - Supports Power failure recovery
 - Able to wake the computer from specific states by Power switch, RTC alarm, USB, PS2 KB&Mouse, Modem ring on COM#1...

● **Onboard PCI Devices**

- ◆ LAN --> Embedded 10/100Mbps Fast Ethernet controller with onboard (Optional) **VIA 6103** PHY

Features

- ◆ IDE--> Embedded IDE controller with 2 ordinary IDE ports up to 4 IDE devices, supports ATA-133 with up to 133MB/sec bandwidth

● Legacy IO Controller

- ◆ [ITE 8705](#) LPC IO controller for floppy, printer, serial, game and CIR/SIR interface

● Audio

- ◆ [Six](#) channel audio with analog and digital output using [C-Media 9739A](#) AC'97 CODEC
 - AC'97 v2.3 compliant
 - In 2-CH mode, supports Line-In (Light blue), Line-Out (Lime) and Mic-In (Pink) at rear panel
 - In 6-CH mode, supports Rear speaker out (Light blue), Front speaker out (Lime) and Center&Subwoofer speaker out (Pink) at rear panel
 - Supports CD-In and S/PDIF-in/out interface
 - Supports Line-out and Mic-In for front panel

● Peripheral Interfaces

☞ At Rear Panel

- ◆ PS/2 keyboard and mouse ports
- ◆ [One](#) Parallel (printer) port
- ◆ [One](#) Serial port
- ◆ [One](#) VGA port
- ◆ [One](#) RJ45 LAN connector (Optional)
- ◆ [Four](#) USB2.0 ports
- ◆ [Three](#) Audio jacks

☞ Onboard connector and pin-header

- ◆ [One](#) floppy drive connector
- ◆ [Two](#) IDE connectors
- ◆ [Two](#) extra USB2.0 ports

- ◆ **One** CD-IN connector
- ◆ **One** S/PDIF in/out connector
- ◆ **One** IR connector
- ◆ **One** Front Panel Audio connector
- ◆ **One** Game port connector
- ◆ **Two** Fan connectors

● **Front Panel Controller**

- ◆ Supports Reset & Soft-Off switches
- ◆ Supports HDD & Power LEDs
- ◆ Supports PC speaker

● **Expansion Slots**

- ◆ **One** AGP slot supporting 1.5v **4X** AGP cards
 - AGP v2.0 compliant
- ◆ **Three** PCI slots with Bus Master support
 - PCI v2.2 compliant

● **Other Features**

- ◆ Magic Health – a BIOS H/W monitoring utility for voltage, temperature and fan-speed sensing displayed during POST
- ◆ EZ Boot – A simple shortcut to select the boot device, e.g. hard drive, CD-ROM or floppy without entering CMOS setup
- ◆ Supports exclusive KBPO (Keyboard Power On) function
- ◆ Excellent Over clocking capabilities through
 - subtle frequency tuning on FSB
 - supports complete Asynchronous FSB/Memory for overclocking
- ◆ Supports AGP card 3.3V Protection

● **Form Factor**

- ◆ 210mm x 245 mm ATX size

Section 3
INSTALLATION

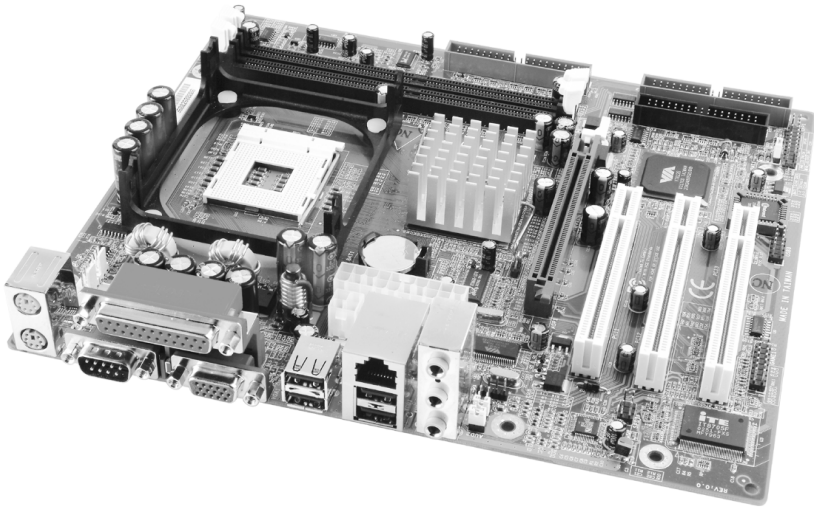

Mainboard Layout

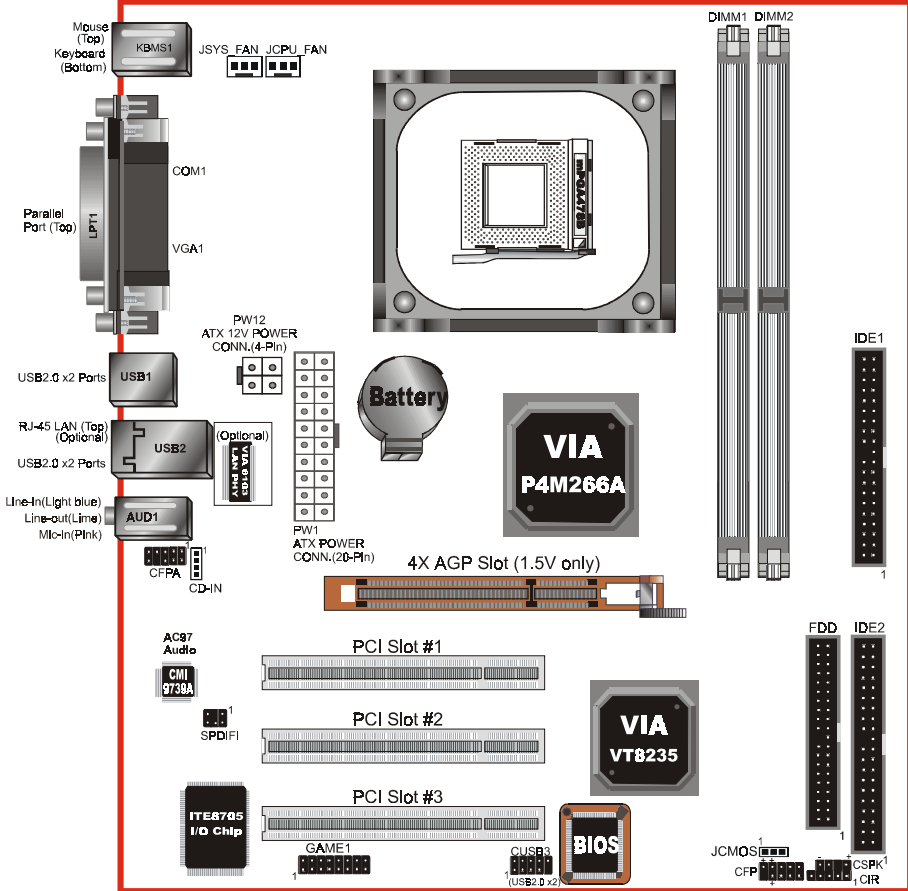

Easy Installation Procedure

The following must be completed before powering on your new system:

- 3-1. **CPU Installation**
- 3-2. **Jumper Settings**
- 3-3. **System Memory Configuration**
- 3-4. **Expansion Slots**
- 3-5. **Device Connectors**

3-1 CPU Installation

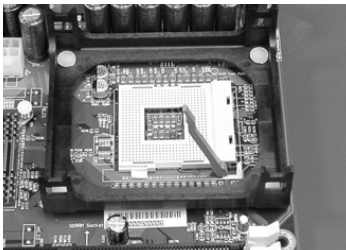

Figure 1

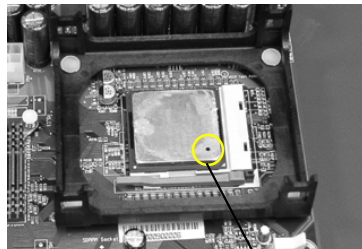

Figure 2

Pin 1

Step 1

Open the socket by raising the actuation lever.

Step 2

Align pin 1 on the CPU with pin 1 on the CPU socket as shown in the illustration above. The CPU is keyed to prevent incorrect insertion. Don't force the processor into the socket. If it does not go in easily, check for mis-orientation and reinsert the CPU.

Make sure the processor is fully inserted into the socket.

Installation

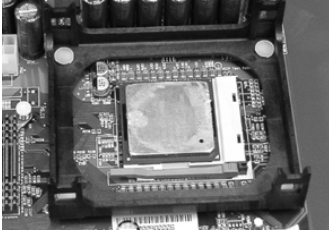

Figure 3

Step 3

Close the socket by lowering and locking the actuation lever.



Figure 4

Step 4

Apply thermal compound to the top of the CPU and install the heatsink as shown.

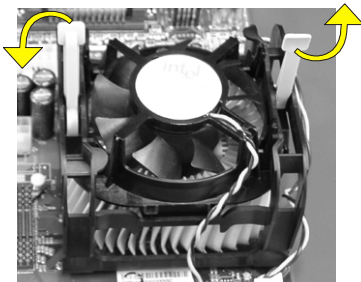

Figure 5

Step 5

Install the cooling fan assembly. Press the two clips in the direction of the arrows shown in Figure 5 to secure the assembly to the CPU socket.

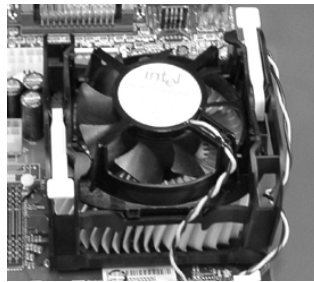

Figure 6

Step 6

Plug the CPU fan into the CPU fan connector.

The installation is complete.

NOTES:

- Damage to Intel Pentium™ 4 processors might result if installed with incorrect CPU fan and heatsink assemblies. Use Intel's design thermal solution shown in the illustrations above: an active heatsink; an extruded aluminum heatsink base; and a fan attached to the top of the fin array.
- Apply heatsink thermal compound or paste to the CPU to avoid CPU overheating and damage.
- In accordance with Intel Corp. specifications, do not install a CPU over 50 times to avoid bending the pins and damaging the CPU.

3-2 Jumper Settings

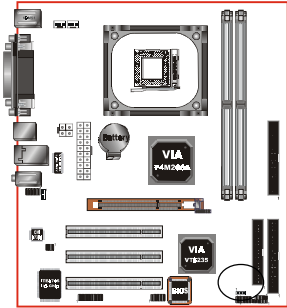

JCMOS: Clear CMOS data Jumper

If the CMOS data becomes corrupted or you forgot the supervisor or user password, clear the CMOS data to reconfigure the system back to the default values stored in the ROM BIOS.

Settings:



1-2: Normal (Default)

2-3: Clear CMOS

To CMOS Clear data, please follow the steps below.

1. Turn off the system.
 2. Change the jumper from “1-2” to “2-3” position for a few seconds.
 3. Replace the jumper on to the “1-2” position.
 4. Turn on the system and hold down the key to enter BIOS setup.
-

Installation

3-3 System Memory Configuration

Memory Layout

The mainboard accommodates two PC1600/PC2100 184-pin DIMMs (Dual In-line Memory Modules):

- Supports up to 2.0GB of 200/266MHz DDR SDRAM
- Supports unbuffered and non-ECC DIMMs
- Supports configurations defined in the JEDEC DDR DIMM specification

Figure 6 and Table 1 show two possible memory configurations.

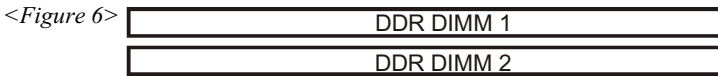

<Table 1>

Total Memory	DDR DIMM 1	DDR DIMM 2
= 1GB Maximum	DDR SDRAM* 64MB, 128MB, 256MB, 512MB, 1GB* X 1	None
= 2GB Maximum	DDR SDRAM* 64MB, 128MB, 256MB, 512MB, 1GB* X 1	DDR SDRAM* 64MB, 128MB, 256MB, 512MB, 1GB* X 1

NOTES:

- Using non-compliant memory with higher bus speeds (overclocking) may severely compromise the integrity of the system.

DIMM Module Installation

Figure 8 displays the notch on the DDR DIMM memory module.

DIMMs have 184 pins and one notch that matches with the DDR DIMM socket. DIMM modules are installed by placing the chip firmly into the socket and pressing straight down as shown in figure 9 until the white clips close and the module fits tightly into the DIMM socket (figure 10).

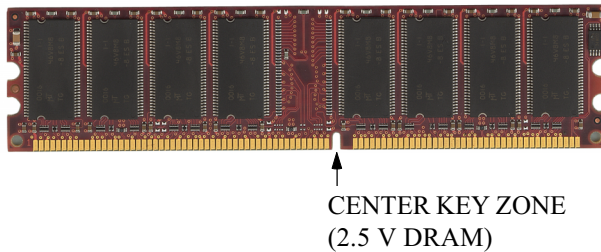

Figure 8 - DIMM notch

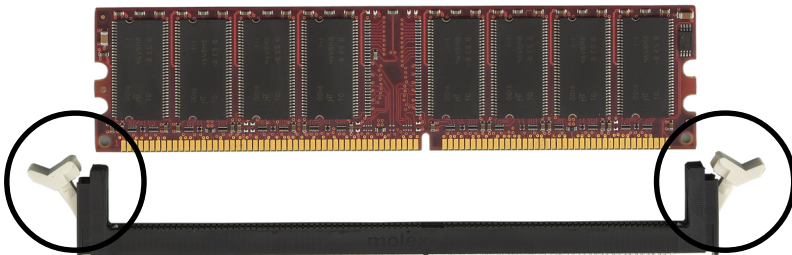

Figure 9 - DIMM module clips before installation

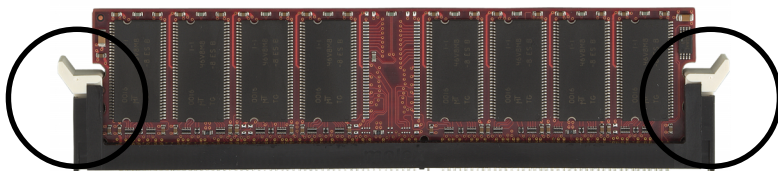
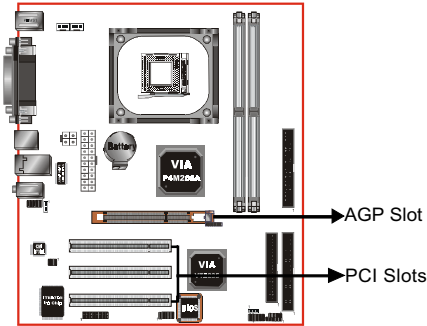

Figure 10 - DIMM module clip after installation

To remove the DIMM module press down the white clips and the module will be ejected from the socket.

Installation

3-4 Expansion Slots



AGP Slot

The mainboard is equipped with an AGP slot. Make sure you install a card that supports the 1.5V specification.

PCI Slots

The mainboard is equipped with 3 PCI slots.

Installing an Expansion Card

The steps below assume that the mainboard is already installed in the system chassis.

1. Make sure the PC and all other peripheral devices connected to its has been powered down.
2. Disconnect all power cords and cables.
3. Remove the system unit cover.
4. Remove the bracket of the slot that you intend to use. (You need to remove the screw in order to remove the bracket.)
5. Align the card above the slot then press it down firmly until it is completely seated in the slot.
6. Secure the card to the chassis with the screw you removed in step 4.
7. Replace the system unit cover.
8. Power on the PC.
9. Enter the BIOS step program to make the necessary settings.
10. Save the settings and restart the PC.
11. Install the software drivers of the expansion cards, if necessary.

AGP Card Installation Caution

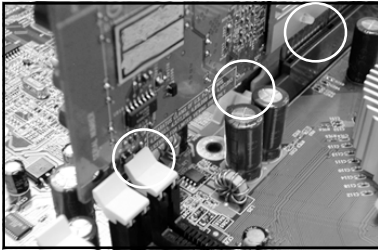

1. AGP card component is blocked by DIMM socket lock.
2. AGP slot clicker is not locked.
3. AGP card edge connector is not inserted properly.

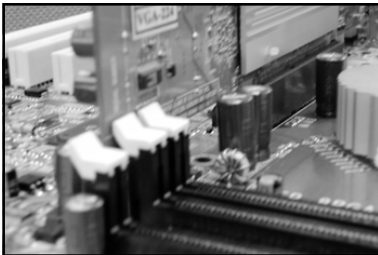

1. AGP card component is not blocked by DIMM socket lock.
2. AGP slot clicker is locked.
3. AGP card edge connector is inserted properly.

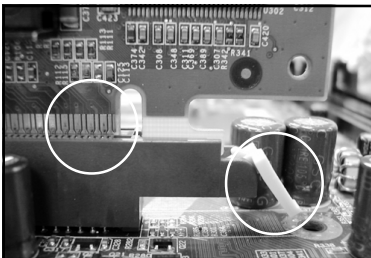

1. AGP slot clicker is not locked.
2. AGP card edge connector is not inserted properly.

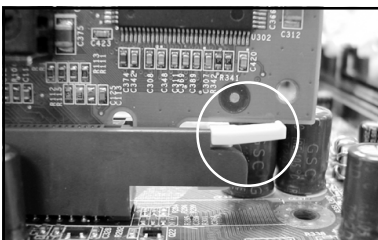

1. AGP slot clicker is locked.
2. AGP card edge connector is inserted properly.



Installation

3-5 Connectors

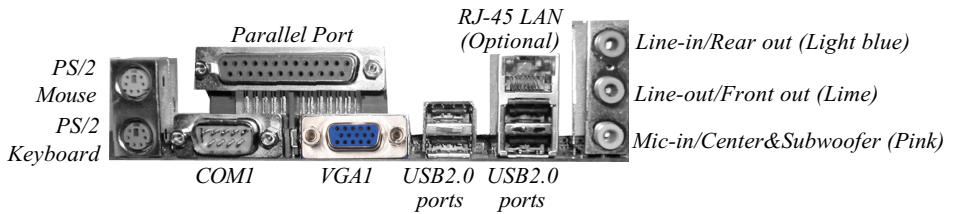
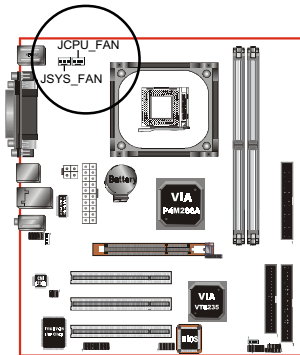

Figure 11 - I/O Ports



JCPU_FAN / JSYS_FAN:

CPU/Chassis Fan Power Connectors

JCPU_FAN: The CPU must be kept cool by using a heatsink with fan assembly.

JSYS_FAN: The chassis fan will provide adequate airflow throughout the chassis to prevent overheating the CPU.

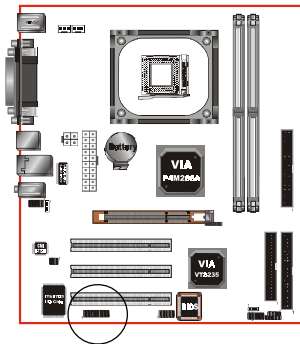
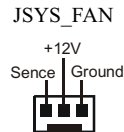
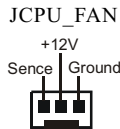

GAME1: Game/MIDI connector

This port works well with any application that is compatible with the standard PC joystick.



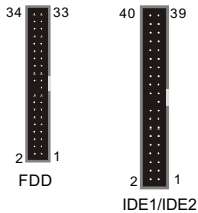
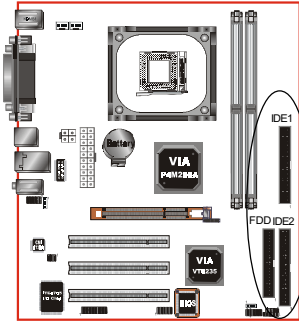

FDD: Floppy Controller Connector
This mainboard is equipped with a floppy disk drive connector for connecting up to 2 floppy disk drives.

IDE1/IDE2: Ultra DMA-66/100/133 Primary/Secondary IDE Connector

This mainboard is equipped with 2 IDE disk connectors for connecting up to 4 ATA-133 IDE drives. It supports PIO and DMA mode operations for maximum data transfer rate of 133MB/sec per channel.



When use two IDE drives, one must be set to Master mode and the other one to Slave mode. Refer to your disk drive user's manual for information about selecting the proper drive switch settings.

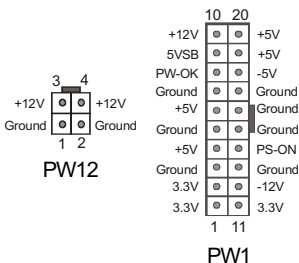
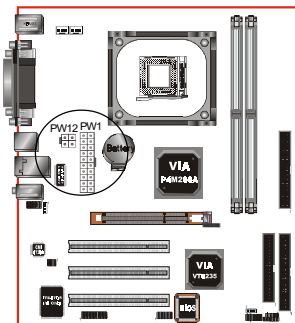

PW1: 20-pin ATX Power Connector

PW12: 4-pin ATX12V Power Connector

The mainboard is equipped with a standard 20-pin ATX main power connector and a 4-pin +12V power connector for connecting an ATX12V power supply. The plugs of the power cables are designed to fit in only one orientation. Find the proper orientation then insert the plugs into the connectors until they fit in place.

Caution:

The PW1 and PW12 Power Connector must be used simultaneously or else this system will not boot-up.



The board requires a minimum of 250 Watt power supply to operate. Your system configuration (amount of memory, add-in cards, peripherals, etc.) may exceed this minimum power requirement. To ensure that adequate power is provided, use a 300 Watt or greater power supply.

Installation

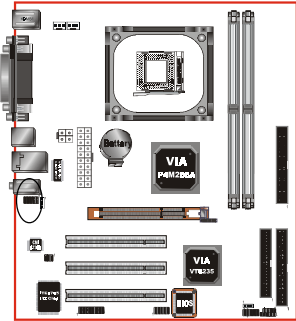

CFPA: Front Panel Audio Connector

When the jumpers are removed this connector can be used for front panel audio.

The front panel line-out phone jack should have a “normal close” switch . Without a phone- plug inserted, the rear panel audio is enabled. With phone plug inserted, the rear panel audio will be disabled.

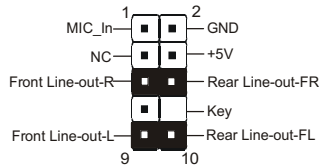

Settings

Pins (5-6) & (9-10) Short (default): Only the onboard rear panel audio jack can be used.

Pins (5-6) & (9-10) Open: Only front panel audio jack can be used.



In 2-Channel audio mode, Mic-In is shared for both front panel and rear panel.
In 6-Channel audio mode, the Mic-In is dedicated for front panel use, and rear panel Mic-In function will switch to Center and Subwoofer support.

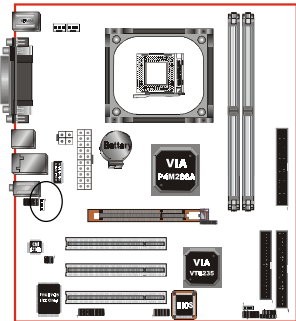

CD-IN: CD Audio_IN Connector

The CD-IN connector is for receiving audio form a CD-ROM drive, TV tuner or MPEG card.

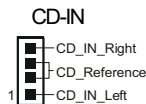

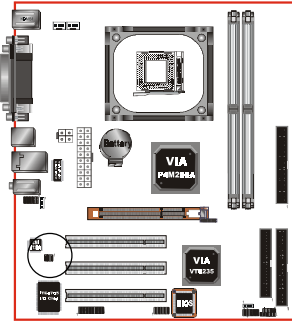

S/PDIF: Sony/Philips Digital InterFace connector

This connector links digital audio between the mainboard and your audio devices, such as CD player, sampler or DAT recorder. It allows the digital transmission of audio data in S/PDIF format.

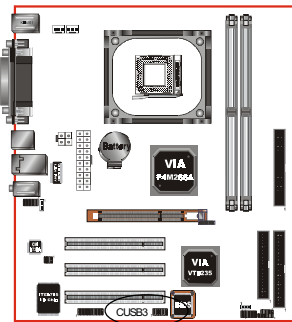
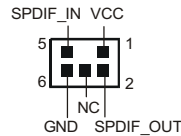

CUSB3: Two USB 2.0 ports

This mainboard includes 2 additional onboard USB ports, identified by two 10-pin connector.

If you wish to use the additional USB ports, install the card-edge bracket to the system chassis then insert its cables to this 10-pin connector.

USB2.0 allows data transfer speed up to 480Mbps.

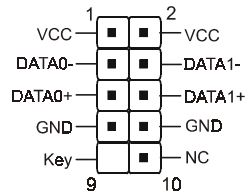

CAUTION!

Please make sure the USB cable has the same pin assignment. A different pin assignment may cause damage to the system.

If you need the USB cable, please contact our retailer.

Installation

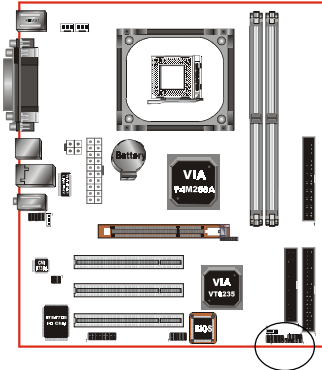

CFP / CIR / CSPK

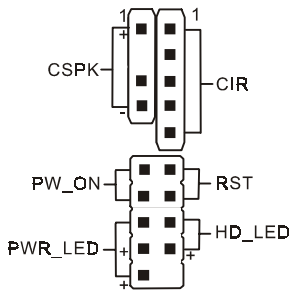

CFP: Front Panel Connector

◆ HD_LED

This LED will light up whenever the hard drive is being accessed.

◆ PWR_LED

This connects to the power button of the system chassis

◆ RST

This switch allows you to reboot without having to power off the system thus prolonging the life of the power supply or system.

◆ PW_ON

This is connected to the power button on the case. Using the Soft-Off by Pwr-BTTN feature, you can choose either Instant Off (turn off system immediately) or 4 sec delay (push the button for 4 seconds to turn off the system). When the system is in 4 sec delay mode, suspend mode is enabled by pushing the button momentarily.

CIR: IR connector

Connect your IrDA cable to this IR connector.

- | | |
|---------|---------|
| 1. VCC | 4. GND |
| 2. NC | 5. IRTX |
| 3. IRRX | |

CSPK: Speaker

Connect to the system's speaker for beeping

- | | |
|--------|------------|
| 1. VCC | 3. GND |
| 2. NC | 4. Speaker |

3-6 External Modem Ring-in Power ON and Keyboard Power ON Functions (KBPO)

Modem-Ring Power ON Function

The I/O chipset provides the two serial ports with the External Modem Ring-in Power ON function. Once you connect an external modem to COM1 or COM2, the mainboard enables you to turn on the system through remote and host dial-up control.

Keyboard Power ON Function

The mainboard features a keyboard power on function that enables you to turn on the power supply using a keypress. Follow these instructions to enable the Keyboard Power ON function .

Step : Use the Keyboard Power ON function (KBPO) to turn on the system by using a key press, password, or hot key combination etc. as set in the BIOS Power Management Setup menu (refer to the BIOS Power Management Setup for details). The BIOS default setting is keyboard Hot key (<Ctrl>+<F1>). To power off the system, use the Soft-OFF function under Windows XP/ME/2000/98. (refer to Windows online help).

NOTES:

- Intel ATX version 2.0 specification recommends a power supply that supplies ≥ 2.0 A in 5.0 VSB. However, this mainboard supports a 5.0 VSB standby power supply ≥ 2 A .
- We recommend you use the power supply with 2.0 A in 5.0 VSB, which supports PCI 2.3 specification for remote power-on and wake-up functions.

Installation

3-7 STR (Suspend To RAM) Function

This mainboard supports the STR (Suspend To RAM) power management scheme by maintaining the appropriate power states in the DDR SDRAM interface signals. The power source to the DDR SDRAM must be kept active during STR (ACPI S3). Advanced Configuration Power Interface (ACPI) provides many Energy Saving Features for operating systems that support Instant ON and QuickStart™ function.

1. To enable STR functionality to save system power :
 - a. Install ACPI certified add-on cards (such as AGP, LAN, and modem cards).
 - b. In BIOS, under Power Management Setup (refer to Section 4), select “ACPI Suspend Type: S3(STR)” and “USB Port Wake Up Control” (if you have a USB mouse or keyboard device).
 - c. Install Windows® XP/2000/ME/98SE.
 - d. Restart the system.
 - e. Open the Control Panel Power Management application, and click the Advanced tab. In the Power buttons section, select “Stand By” from the drop-down lists.
2. To activate the STR function, click the START button and choose Shut Down. In the Shut Down Windows dialog box, select the Stand By option to enter STR mode.

The following are the differences between STR power saving mode and Green (or Suspend) mode:

- a. STR is the most advanced Power Management mode.
- b. STR cuts all the power supplied to peripherals except to memory - max. power saving.
- c. STR saves and keeps all on-screen data including any executed applications to DDR SDRAM.
- d. In STR mode, you must push the power button (connected to the onboard PW-On of CFP pin), click your USB mouse buttons, or press your USB keyboard keys to wake up your system to the last display.

3-8 Supports AGP Card 3.3V Protection

The VIA P4M266A chipset supports 1.5 volt AGP graphics cards only. Inserting a 3.3 volt AGP card on an VIA P4M266A based mainboard might damage the chipset. However, this mainboard features a protection function that prevents the system from powering on when a 3.3V AGP card is inadvertently inserted into the AGP slot.

Should this happen, we recommend you to follow these steps:

- Step 1:** Remove the 3.3V AGP card from the AGP slot.
- Step 2:** Unplug the ATX/ATX12V power cable.
- Step 3:** Insert a 1.5V AGP card into the AGP slot.
- Step 4:** Wait for 5 ~ 7 seconds and then plug in the ATX/ATX12V power cord again (or turn on the ATX/ATX12V power switch) to turn on your system.

Note: There should be an interval of 5 ~ 7 seconds between unplugging and plugging in the power cord, or turning the ATX/ATX12V power supply on and off.

Section 4

BIOS SETUP

Main Menu

The ROM BIOS provides a built-in Setup program which allows user to modify the basic system configuration and hardware parameters. The modified data is stored in a battery-backed CMOS, so that data will be retained even when the power is turned off. In general, the information saved in the CMOS RAM will stay unchanged unless there is a configuration change in the system, such as hard drive replacement or a device is added.

It is possible for the CMOS battery to fail causing CMOS data loss. If this happens you will need install a new CMOS battery and reconfigure your BIOS settings.

 The BIOS setup screen and description are for reference only, and may not exactly match what you see on your screen. The contents of BIOS are subject to change without notice. Please visit our website for updates.

To enter the Setup Program :

Power on the computer and press the key during the POST (Power On Self Test). The BIOS CMOS SETUP UTILITY opens.

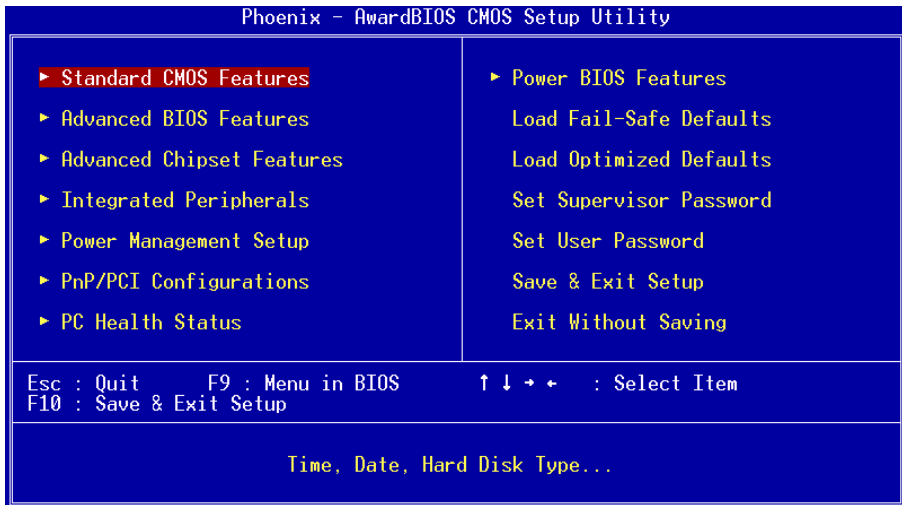

Figure 1: CMOS Setup Utility

BIOS

The main menu displays all the major selection items. Select the item you need to reconfigure. The selection is made by moving the cursor (press any direction (arrow key)) to the item and pressing the 'Enter' key. An on-line help message is displayed at the bottom of the screen as the cursor is moved to various items which provides a better understanding of each function. When a selection is made, the menu of the selected item will appear so that the user can modify associated configuration parameters.

4-1 Standard CMOS Setup

Choose "STANDARD CMOS FEATURES" in the CMOS SETUP UTILITY Menu (Figure 2). Standard CMOS Features Setup allows the user to configure system settings such as the current date and time, type of hard disk drive installed, floppy drive type, and display type. Memory size is auto-detected by the BIOS and displayed for your reference. When a field is highlighted (use direction keys to move the cursor and the <Enter> key to select), the entries in the field can be changed by pressing the <PgDn> or the <PgUp> key.

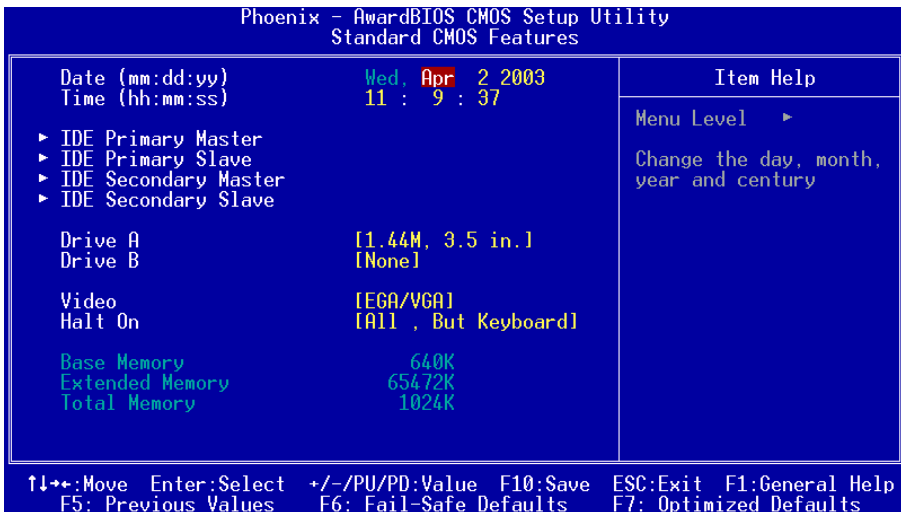

Figure 2: Standard CMOS Setup

Notes:

- If the hard disk Primary Master/Slave and Secondary Master/Slave are set to Auto, the hard disk size and model will be auto-detected.
- The “Halt On:” field is used to determine when the BIOS will halt the system if an error occurs.
- Floppy 3 Mode support is a mode used to support a special 3.5-inch drive used in Japan. This is a 3.5-inch disk that stores 1.2 MB. The default setting for this is disabled.

4-2 Advanced BIOS Features

Selecting the “ADVANCED BIOS FEATURES” option in the CMOS SETUP UTILITY menu allows users to change system related parameters in the displayed menu. This menu shows all of the manufacturer’s default values for the board.

Pressing the [F1] key displays a help message for the selected item.

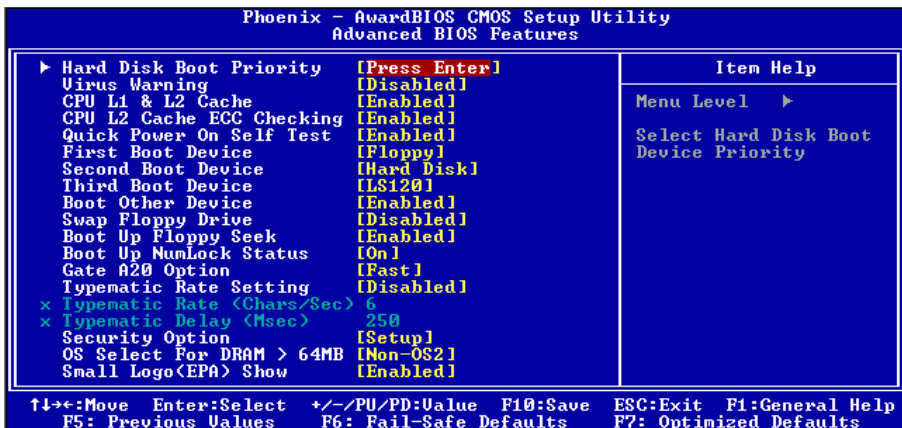

Figure 3: BIOS Features Setup

Hard Disk Boot Priority

This item allows you to select the hard disk boot priority.

BIOS

Virus Warning

During and after system boot up, any attempt to write to the boot sector or partition table of the hard disk drive halts the system and an error message appears.

You should then run an anti-virus program to locate the virus. Keep in mind that this feature protects only the boot sector, not the entire hard drive.

Enabled: Activates automatically when the system boots up causing a warning message to appear when anything attempts to access the boot sector.

Disabled: No warning message appears when anything attempts to access the boot sector.

Note: Many disk diagnostic programs that access the boot sector table can trigger the virus warning message. If you plan to run such a program, we recommend that you first disable the virus warning.

CPU L1 & L2 Cache

This controls the status of the processor's internal and external (L2) cache area.

Options: Enabled, Disabled.

CPU L2 Cache ECC Checking

This item allows you to enable/disable CPU L2 Cache ECC checking.

Options: Enabled, Disabled.

Quick Power On Self Test

This category speeds up the Power On Self Test (POST). The default is Enabled.

Enabled: This setting will shorten or skip of the items checked during POST.

Disabled: Normal POST.

First /Second/Third/Other Boot Device

The BIOS attempts to load the operating system from the devices in the sequence selected in these items.

Options: Floppy, LS120, HDD-0, SCSI, CDROM, HDD-1, HDD-2, HDD-3, ZIP100, USB-FDD, USB-ZIP, USB-CDROM, USB-HDD, LAN, Disabled.

Boot Other Device

When enabled, the system searches all other possible locations for an operating system if it fails to find one in the devices specified under the first, second, and third boot devices. The default is Enabled.

Options: Enabled, Disabled.

Swap Floppy Drive

This will swap your physical drive letters A & B if you are using two floppy disks.

Options: Enabled, Disabled.

Boot Up Floppy Seek

If this item is enabled, it checks the size of the floppy disk drives at start-up time.

You don't need to enable this item unless you have a legacy diskette drive with 360K capacity. The default is Disabled.

Options: Enabled, Disabled.

Boot Up NumLock Status

This controls the state of the NumLock key when the system boots. The default is On.

On: The keypad acts as a 10-key pad.

Off: The keypad acts like cursor keys.

Typematic Rate Setting

This determines the keystrokes repeat rate. The default is Disabled.

Enabled: Allows typematic rate and typematic delay programming.

Disabled: The typematic rate and typematic delay will be controlled by the keyboard controller in your system.

Typematic Rate (Chars/Sec)

This is the number of characters that will be repeated by a keyboard press.

The default is 6.

Options: 6 ~ 30 characters per second.

Typematic Delay (msec)

This setting controls the time between the first and the second character displayed by typematic auto-repeat. The default is 250.

Options: 250/500/750/1000 msec.

Security Option

This category allows you to limit access to the System and Setup, or just to Setup.

The default is Setup.

System: The system will not boot and the access to Setup will be denied if the correct password is not entered at the prompt.

Setup: The system will boot; but the access to Setup will be denied if the incorrect password is not entered at the prompt.

BIOS

OS Select For DRAM > 64 MB

Some operating systems require special handling. Use this option only if your system has greater than 64 MB of memory. The default is Non-OS2.

OS2: Select this if you are running the OS/2 operating system with greater than 64 MB of RAM.

Non-OS2: Select this for all other operating systems and configurations.

Small Logo (EPA) Show

If the BIOS contains an internal bitmap picture, this option sets the bitmap display at the top right corner of the screen.

Options: Enabled, Disabled.

4-3 Advanced Chipset Features

Choose the “ADVANCED CHIPSET FEATURES” option in the CMOS SETUP UTILITY menu to display following menu.

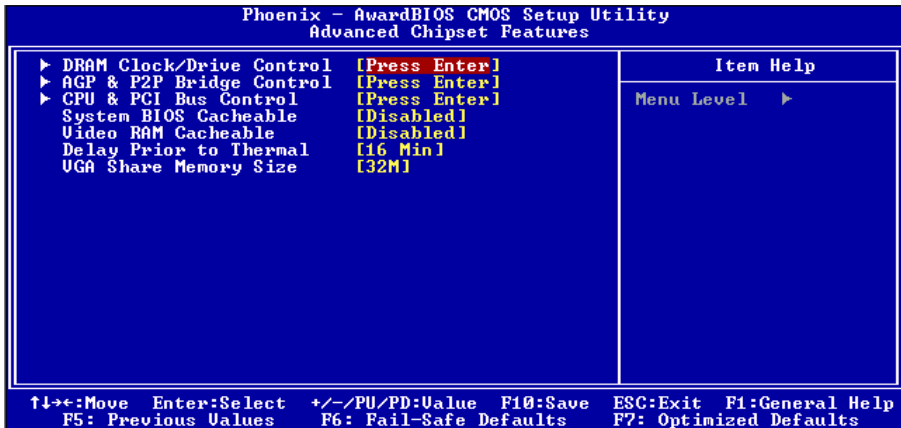

Figure 4: Chipset Features Setup

System BIOS Cacheable

This item allows the system to be cached in memory for faster execution.

Options: Disabled, Enabled.

Video RAM Cacheable

This option allows the CPU to cache read/writes of the video RAM.

Options: Disabled, Enabled.

Delay Prior to Thermal

Set this item to enable the CPU Thermal function to engage after the specified time.

The default is 16 minutes.

Options: 4, 8, 16, 32 minutes.

VGA Share Memory Size

This item allows you to select the VGA share memory size for video.

Options: 8M, 16M, 32M, Disabled.

BIOS

► DRAM Clock / Drive Control

Scroll to DRAM Clock/Drive Control and press <Enter>. The following screen appears:

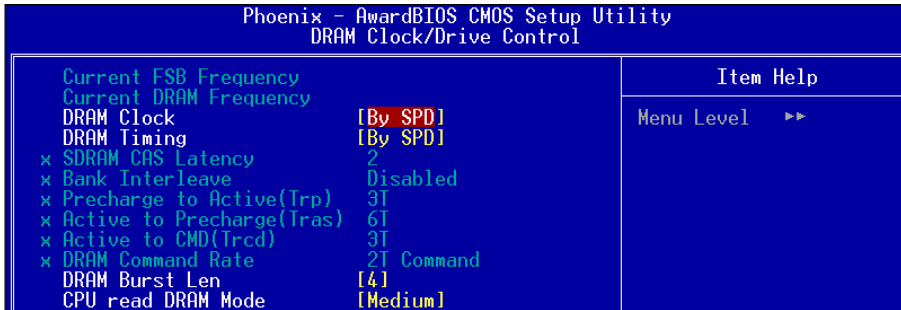

Current FSB Frequency

Display the current CPU front side bus frequency information.

Current DRAM Frequency

Display the current DRAM frequency information.

DRAM Clock

This item allows you to select DRAM clock.

Options: By SPD, 100MHz, 133MHz.

DRAM Timing

For setting DRAM Timing select By SPD to follow SDRAM Serial Presence Detect Specification.

Options: Manual, Auto by SPD.

DRAM CAS Latency

Enables you to select the CAS latency time. The value is set at the factory depending on the DRAM installed. Do not change the values in this field unless you change specifications of the installed DRAM and DRAM clock from DRAM Timing Selectable.

The default is set by SPD (see 'DRAM Timing').

Options: 2, 2.5.

Bank Interleave

The item allows you to set how many banks of SDRAM support in your mainboard.

Default is by SPD.

Options: 2 Bank, 4 Bank, Disabled.

Precharge to Active (Trp)

This item refers to the number of cycles required to return data to its original location to close the bank or the number of cycles required to page memory before the next bank activate command can be issued. The default is by DRAM SPD.

Options: 3T, 2T.

Active to Precharge (Tras)

This item sets the minimum RAS pulse width. The default is by DRAM SPD.

Options: 5T, 6T.

Active to CMD (Trcd)

This item sets the timing parameters for the system memory such as the CAS (Column Address Strobe) and RAS (Row Address Strobe). The default is by DRAM SPD.

Options: 3T, 2T.

DRAM Command Rate

Setup the timing at each cycle.

Options: 1T Command, 2T Command.

BIOS

▶ AGP & P2P Bridge Control

Scroll to AGP & P2P Bridge Control and press <Enter>. The following screen appears:

Phoenix - AwardBIOS CMOS Setup Utility		
AGP & P2P Bridge Control		
		Item Help
AGP Aperture Size	[64M]	
AGP Mode	[4X]	
AGP Driving Control	[Auto]	
* AGP Driving Value	DA	Menu Level ▶▶
AGP Fast Write	[Disabled]	
AGP Master 1 WS Write	[Enabled]	
AGP Master 1 WS Read	[Enabled]	

AGP Aperture Size (MB)

This item defines the size of the aperture if you use an AGP graphics adapter. It refers to a section of the PCI memory address range used for graphics memory. Options: 4M, 8M, 16M, 32M, 64M, 128M, 256M.

AGP Mode

Chipset AGP Mode support.
Options: 1X, 2X, 4X.

AGP Driving Control

This item allows you to adjust the AGP driving force. Choose Manual to key in a AGP Driving Value in the next selection. This field is recommended to set in **Auto** for avoiding any error in your system.
Options: Auto, Manual.

AGP Fast Write

Selecting Enabled allows to use Fast Write Protocol for 4X AGP card.
Options: Enabled, Disabled.

AGP Master 1 WS Write

When Enabled, Writes to the AGP (Accelerated Graphics Port) are executed with one wait states.
Options: Enabled, Disabled.

AGP Master 1 WS Read

When Enabled, Reads to the AGP (Accelerated Graphics Port) are executed with one wait states.
Options: Enabled, Disabled.

► CPU & PCI Bus Control

Scroll to CPU & PCI Bus Control and press <Enter>. The following screen appears:

Phoenix - AwardBIOS CMOS Setup Utility	
CPU & PCI Bus Control	
CPU to PCI Write Buffer	[Disabled]
PCI Master 0 WS Write	[Disabled]
PCI Delay Transaction	[Disabled]
	Item Help
	Menu Level >>

CPU to PCI Write Buffer

When enabled, up to four words of data can be written to the PCI bus without interrupting the CPU. When disabled, a write buffer is not used and the CPU read cycle will not be completed until the PCI bus signals that it is ready to receive the data.

Options: Enabled, Disabled.

PCI Master 0 WS Write

When Enabled, Writes to the PCI bus are commanded with zero wait states.

Options: Enabled, Disabled.

PCI Delay Transaction

The chipset has an embedded 32-bit posted write buffer to support delay transactions cycles. Select Enabled to support compliance with PCI specification version 2.3.

Options: Enabled, Disabled.

BIOS

4-4 Integrated Peripherals

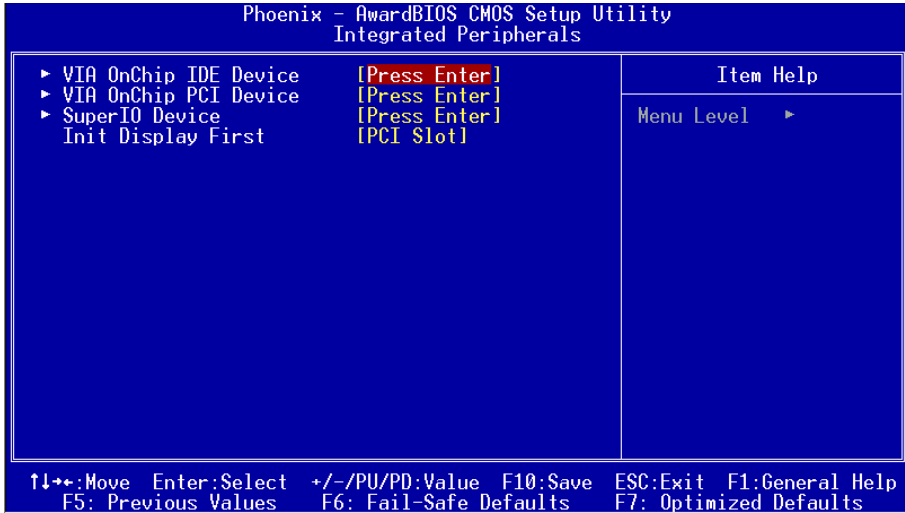

Figure 5: Integrated Peripherals

Init Display First

If two video cards are used (1 AGP and 1 PCI) this specifies which one will be the primary display adapter. The default is PCI Slot.

Options: PCI Slot, AGP.

▶ VIA OnChip IDE Device

Scroll to VIA Onchip IDE Device and press <Enter>. The following screen appears:

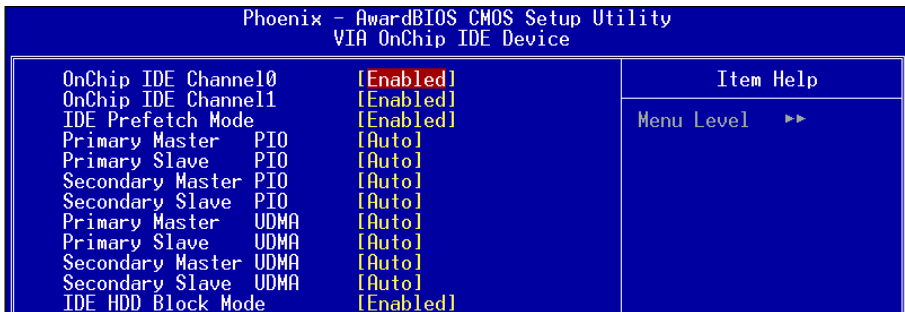

OnChip IDE Channel0/1

The integrated peripheral controller contains an IDE interface with support for two IDE channels. Select "Enabled" to activate each channel separately.

Options: Enabled, Disabled.

Note: If you do not use the onboard IDE connector, then you will need to set the Onboard Primary PCI IDE and Onboard Secondary PCI IDE to "Disabled".

IDE Prefetch Mode

Selecting "Enabled" reduces latency between each drive read/write cycle, but may cause instability in IDE subsystems that cannot support such fast performance. If you are getting disk drive errors, try setting this value to Disabled. This field does not appear when the Internal PCI/IDE field, above, is Disabled.

Options: Enabled, Disabled.

Primary/Secondary Master/Slave PIO

The four IDE PIO (Programmed Input/Output) fields let you set a PIO mode (0-4) for each of the four IDE devices that the onboard IDE interface supports. Modes 0 to 4 provide successively increased performance. In Auto mode, the system automatically determines the best mode for each device.

Options: Auto, Mode 0 ~ 4.

Primary/Secondary Master/Slave UDMA

Select the mode of operation for the IDE drive. Ultra DMA-33/66/100/133 implementation is possible only if your IDE hard drive supports it and the operating environment includes a DMA driver. If your hard drive and your system software both support Ultra DMA-33/66/100/133, select Auto to enable UDMA mode by BIOS.

Options: Auto, Disabled.

IDE HDD Block Mode

Block mode is also called block transfer, multiple commands, or multiple sector read/write. If your IDE hard drive supports block mode (most new drives do), select Enabled for automatic detection of the optimal number of block read/writes per sector the drive can support.

Options: Enabled, Disabled.

BIOS

▶ VIA Onchip PCI Device

Scroll to VIA Onchip PCI Device and press <Enter>. The following screen appears:

Phoenix - AwardBIOS CMOS Setup Utility		
VIA OnChip PCI Device		
VIA-3058 AC97 Audio	[Auto]	Item Help
VIA-3043 OnChip LAN	[Auto]	
VIA-6102 MAC Address Input	[Press Enter]	Menu Level ▶▶
Onboard Lan Boot ROM	[Disabled]	
OnChip USB Controller	[All Enabled]	
OnChip EHCI Controller	[Enabled]	
USB Keyboard Support	[Disabled]	
USB Mouse Support	[Disabled]	

VIA-3058 AC97 Audio

This item allows you to disable the chipset on-chip support for AC97 Audio.

Options: Auto, Disabled.

VIA-3043 Onchip LAN (Optional)

Enables the onboard LAN feature.

Options: Auto, Disabled.

VIA-6102 MAC Address (Optional)

Allows you to input the VIA-6102 MAC address.

Onboard Lan Boot ROM (Optional)

Enable/disable the onboard LAN Boot ROM.

Options: Enabled, Disabled.

Onchip USB Controller

Enables the USB controller.

Options: All Enabled, All Disabled, 1&2 USB Port, 2&3 USB Port, 1&3 USB Port, 1 USB Port, 2 USB Port, 3 USB Port.

Onchip EHCI Controller

Enables the EHCI (USB2.0) controller.

Options: Enabled, Disabled.

USB Keyboard Support

Enable/disable support for USB keyboard.

Options: Enabled, Disabled.

USB Mouse Support

Enable/disable support for USB mouse.

Options: Enabled, Disabled.

► **Super IO Chip Setup**

Scroll to Super IO Chip Setup and press <Enter>. The following screen appears:

Phoenix - AwardBIOS CMOS Setup Utility		Item Help
SuperIO Device		Menu Level >>
Onboard FDC Controller	[Enabled]	
Onboard Serial Port 1	[3F8/IRQ4]	
Infrared Port Select	[Disabled]	
UR2 Duplex Mode	[Half]	
Onboard Parallel Port	[378/IRQ7]	
Parallel Port Mode	[SPP]	
ECP Mode Use DMA	[3]	
Game Port Address	[201]	
Midi Port Address	[330]	
Midi Port IRQ	[10]	

Onboard FDC Controller

Select Enabled if your system has a floppy disk controller (FDC) installed on the system board and you wish to use it. If you install add-in FDC or the system has no floppy drive, select Disabled in this field.

Options: Enabled, Disabled.

Onboard Serial Port 1

Select an address and corresponding interrupt for the first serial port.

Options: 3F8/IRQ4, 2E8/IRQ3, 3E8/IRQ4, 2F8/IRQ3, Disabled, Auto.

Infrared Port Select

Select an address for Infrared port.

Options: 3F8/IRQ4, 2E8/IRQ3, 3E8/IRQ4, 2F8/IRQ3, Disabled, Auto.

UR2 Duplex Mode

This item allows you to select IR half/full duplex function.

Options: Half, Full.

Onboard Parallel Port

This field allows the user to configure the LPT port.

Options: 378/IRQ7, 278/IRQ5, 3BC/IRQ7, Disabled.

Parallel Port Mode

This field allows the user to select the parallel port mode.

Options: SPP, EPP, ECP, ECP+EPP.

ECP Mode USE DMA

This field allows the user to select DMA1 or DMA3 for the ECP mode.

Options: DMA1, DMA3.

BIOS

Game Port Address

Select an address for the Game port.

Options: 201, 209, Disabled.

Midi Port Address

Select an address for the Midi port.

Options: 300, 330, Disabled.

Midi Port IRQ

Select an interrupt for the Midi port.

Options: 5, 10.

4-5 Power Management Setup

Choose the “POWER MANAGEMENT SETUP” in the CMOS SETUP UTILITY to display the following screen. This menu allows the user to modify the power management parameters and IRQ signals. In general, these parameters should not be changed unless it’s absolutely necessary.

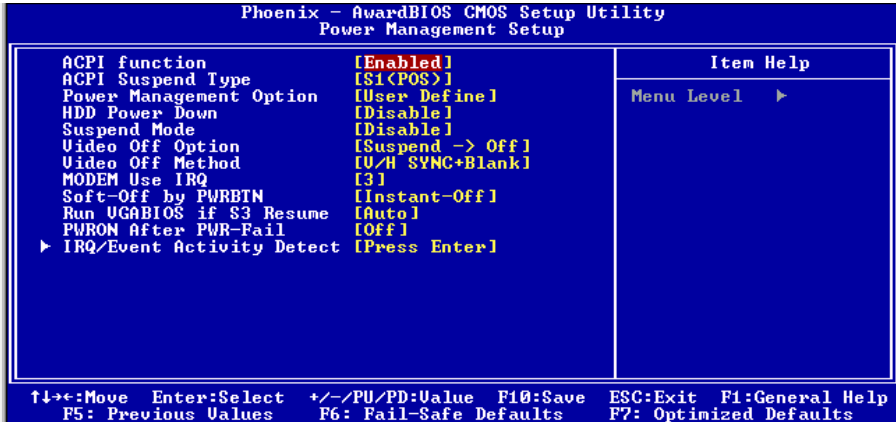

Figure 6: Power Management

ACPI Function

This option allows you to select ACPI Function. The default is Enabled.

Options: Enabled, Disabled.

ACPI Suspend Type

This item allows you to select S1(POS) or S3(STR) function.

Options: S1(POS), S3(STR), S1&S3.

Power Management Option

Use this to select your Power Management selection. The default is User define.

Max. saving: Maximum power savings. Inactivity period is 1 minute in each mode.

Min. saving: Minimum power savings. Inactivity period is 1 hour in each mode.

User define: Allows user to define PM Timers parameters to control power saving mode.

BIOS

HDD Power Down

When enabled and after the set time of system inactivity, the hard disk drive will be powered down while all other devices remain active.

Options: Enabled, 1Min ~ 15Min.

Suspend Mode

enabled and after the set time of system inactivity, all devices except the CPU will be shut off.

Options: Enabled, 1 , 2, 4 ,6, 8, 10, 20, 30, 40min and 1hour .

Video Off Option

When enabled, this feature allows the VGA adapter to operate in a power saving mode.

Always On: Monitor will remain on during power saving modes.

Suspend->Off: Monitor blanked when the systems enters the suspend mode.

Video Off Method

This option allows you to select how the video will be disabled by the power management. The default is V/H Sync + Blank

V/H Sync + Blank: System turns off vertical and horizontal synchronization ports and writes blanks to the video buffer.

DPMS Support: Select this option if your monitor supports the Display Power Management Signaling (DPMS) standard of the Video Electronics Standards Association (VESA). Use the software supplied for your video subsystem to select video power management values.

Blank Screen: System only writes blanks to the video buffer.

MODEM Use IRQ

Name the interrupt request (IRQ) line assigned to the modem (if any) on your system. Activity of the selected IRQ always awakens the system. Default is IRQ 3.

Options: N/A, 3, 4, 5, 7, 9, 10, 11

Soft-Off by PWRBTN

Pressing the power button for more than 4 seconds forces the system to enter the Soft-Off state when the system has “hung.” The default is Instant-off.

Options: Delay 4 Sec, Instant-Off.

Run VGABIOS if S3 Resume

This determines whether or not to enable the system to run the VGA BIOS when resuming from S3(STR) or S1&S3.

Options: Auto, Yes, No.

PWRON After PWR-Fail

Configures the system to auto-restart or remain off after a power interrupt.

Off: System remains off after a power interrupt.

On: System always restarts after a power interrupt.

Auto: Depends on whether the system was safely shutdown before power failure.

► **IRQ/Event Activity Detect**

Scroll to IRQ/Event Activity Detect and press <Enter>. The following screen appears:

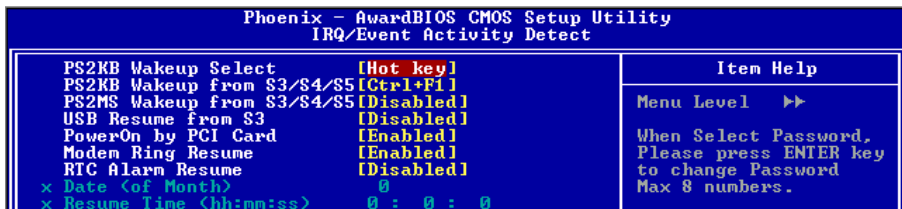

PS2KB Wakeup Select

This item allows you to select Hot Key or Password to wake-up the system by PS2 Keyboard. When select Password, please press ENTER key to change password max 8 numbers.

Options: Hot key, Password.

PS2KB Wakeup form S3/S4/S5

This item allows you to set a Hot Key to wake-up the system by PS2 Keyboard from S3/S4/S5 mode.

Options: Disabled, Ctrl+F1, Ctrl+F2, Ctrl+F3, Ctrl+F4, Ctrl+F5, Ctrl+F6, Ctrl+F7, Ctrl+F8, Ctrl+F9, Ctrl+F10, Ctrl+F11, Ctrl+F12, Power, Wake, Any key.

Note: Power and Wake are Windows98 Keyboard button.

PS2MS Wakeup form S3/S4/S5

This item allows you to wake-up the system by PS2 Mouse from S3/S4/S5 mode.

Options: Enabled, Disabled.

BIOS

USB Resume from S3

This item allows you to wake-up the system by USB device when you save the computer power at S3.

Options: Enabled, Disabled.

PowerOn by PCI Card

An input signal from PME on the PCI card awakens the system from a soft off state.

Options: Enabled, Disabled.

Modem Ring Resume

When set to *Enabled*, any event occurring to the Modem Ring will awaken a system which has been powered down.

Options: Enabled, Disabled.

RTC Alarm Resume

When set to *Enable rtc alarm resume*, you could set the date (of month) and timer (hh:mm:ss), any event occurring at will awaken a system which has been powered down.

4-6 PNP/PCI Configuration

This page lets the user to modify the PCI/ISA IRQ signals when various PCI cards are inserted.

WARNING: Conflicting IRQ's may cause the system to not find certain devices.

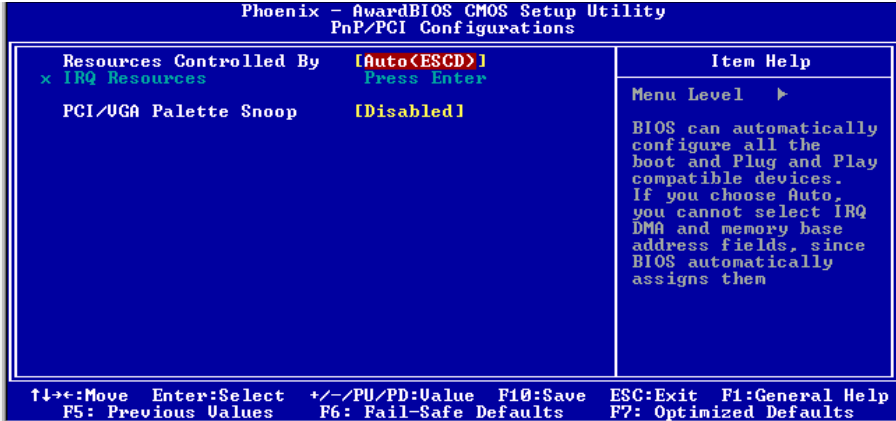

Figure 7: PNP/PCI Configuration Setup

Resources Controlled By

Determines what controls system PNP/PCI resources. The default is Auto (ESCD).

Manual: PNP Card's resources are controlled manually. The "IRQ Resources" field becomes available and you can set which IRQ-X and DMA-X are assigned to PCI and onboard devices.

Auto: BIOS assigns the interrupt resource automatically.

PCI/VGA Palette Snoop

This item is designed to overcome problems that may be caused by some nonstandard VGA cards. This board includes a built-in VGA system that does not require palette snooping therefore you must leave this item disabled.

Options: Enabled, Disabled.

BIOS

Interrupt requests are shared as shown below:

	INT A	INT B	INT C	INT D
PCI 1	V			
PCI 2		V		
PCI 3			V	
AGP Slot	V			
AC97			V	
Onboard USB1	V			
Onboard USB2		V		
Onboard USB3			V	
USB2.0				V
Onboard LAN (Optional)	V			

IMPORTANT!

When using PCI cards on shared IRQ slots, make sure its drivers support “Shared IRQ”, or that the cards do not need IRQ assignments. IRQ conflicts between the two PCI groups will make the system unstable or cards inoperable.

4-7 PC Health Status

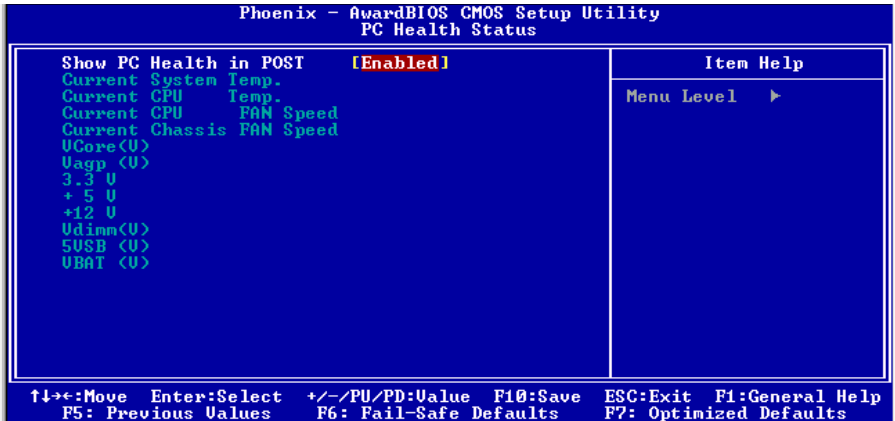

Figure 8: PC Health Status

Show PC Health in POST

When this function is enabled the PC Health information is displayed during the POST (Power On Self Test).

Options: Disabled, Enabled.

Current System/CPU Temperature

Displays the current system/CPU temperature.

Current CPU/Chassis FAN Speed

Displays the current speed of the CPU and chassis fan speed in RPMs.

Vcore (V)

The voltage level of the CPU(Vcore).

Vagp (V)

The voltage level of power supplied to AGP card.

3.3V, 5V, 12V, 5VSB

The voltage level of the switching power supply.

Vdimm (V)

The voltage level of the DRAM

VBAT (V)

The voltage level of the battery.

4-8 Power BIOS Features

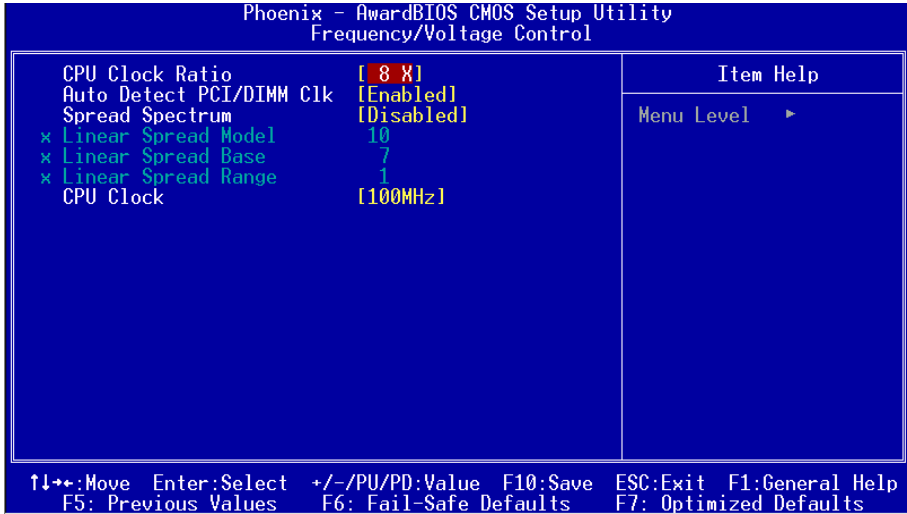

Figure 9: Frequency/Voltage Control

CPU Clock Ratio

Use this item to select a multiplier for the system front side bus (FSB) frequency. The value of the multiplier must be set so that:

$$\text{Multiplier} \times \text{Front side Bus Frequency} = \text{CPU Clock Speed}$$

For example, if you have a processor that is rated to run at 800 MHz and the system is running a front side bus frequency of 100 MHz, you should select a multiplier of 8 so that:

$$8 (\text{Multiplier}) \times 100 \text{ MHz (front side bus)} = 800 \text{ MHz (CPU clock)}$$

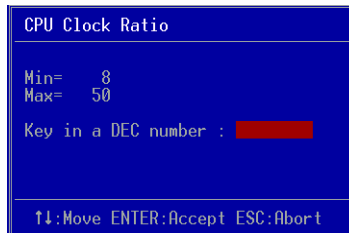

Key in the DEC (decimal) number for the CPU Clock Ratio.

Auto Detect PCI/DIMM Clk

When enabled the mainboard automatically disables the clock source for a PCI/ DIMM slot which does not have a module in it, reducing EMI (ElectroMagnetic Interference).

Options: Enabled, Disabled.

Spread Spectrum

If you enable spread spectrum, it can significantly reduce the EMI (ElectroMagnetic Interference) generated by the system.

Options: Disabled, Enabled.

CPU Clock

Enables you to set the CPU front side bus speed at increments of 1MHz step. The default is 100 MHz. Press <Enter> to display the following screen:

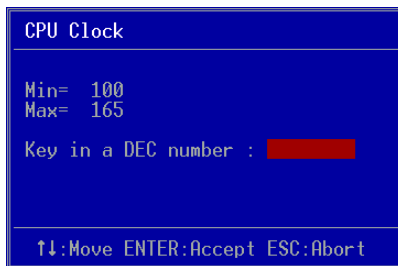

Key in the DEC (decimalism) number for the CPU clock.

Note: Overclocking failure will cause no display on monitor. At this instant, press “*Insert*” key to revert back to the initial or default setting to boot up your system.

BIOS

4-9 Defaults Menu

Selecting “Defaults” from the main menu shows you two options which are described below

Load Fail-Safe Defaults

When you press <Enter> on this item you get a confirmation dialog box:

Load Fail-Safe Defaults (Y/N) ? N

Pressing ‘Y’ loads the BIOS default values for the most stable, minimal-performance system operations.

Load Optimized Defaults

When you press <Enter> on this item you get a confirmation dialog box:

Load Optimized Defaults (Y/N) ? N

Pressing ‘Y’ loads the default values that are factory settings for optimal performance system operations.

4-10 Supervisor/User Password Setting

You can set either supervisor or user password, or both. The differences between are:

- supervisor password:** full rights to enter and change the options of the setup menus.
user password: only enter but do not have the right to change the options of the setup menus.

When you select this function, the following message will appear at the center of the screen to assist you in creating a password.

ENTER PASSWORD:

Type the password, up to eight characters in length, and press <Enter>. The password typed now will clear any previously entered password from CMOS memory. You will be asked to confirm the password. Type the password again and press <Enter>. You may also press <Esc> to abort the selection and not enter a password.

To disable a password, just press <Enter> when you are prompted to enter the password. A message will confirm the password will be disabled. Once the password is disabled, the system will boot and you can enter Setup freely.

PASSWORD DISABLED.

When a password has been enabled, you will be prompted to enter it every time you try to enter Setup. This prevents an unauthorized person from changing any part of your system configuration.

Additionally, when a password is enabled, you can also require the BIOS to request a password every time your system is rebooted. This would prevent unauthorized use of your computer.

You can determine when the password is required within the BIOS Features Setup Menu and its Security option. If the Security option is set to "System", the password will be required both at boot and at entry to Setup. If set to "Setup", prompting only occurs when trying to enter Setup.

BIOS

4-11 Exiting BIOS

Save & Exit Setup

Pressing <Enter> on this item asks for confirmation:

Save to CMOS and EXIT (Y/N)? Y

Pressing “Y” stores the selections made in the menus in CMOS – a special section of memory that stays on after you turn your system off. The next time you boot your computer, the BIOS configures your system according to the Setup selections stored in CMOS. After saving the values the system is restarted again.

Exit Without Saving

Pressing <Enter> on this item asks for confirmation:

Quit without saving (Y/N)? Y

This allows you to exit Setup without storing in CMOS any change. The previous selections remain in effect. This exits the Setup utility and restarts your computer.

Section 5 Driver Installation

Easy Driver Installation



Insert the bundled CD-disk, the main menu screen will appear. The main menu displays buttons that link you to the supported drivers, utilities and software.

- Step 1 :** Click “VIA SERIES PACK 4IN1 DRIVER” to install chipset driver.
- Step 2 :** Click “C-MEDIA AUDIO DRIVER” to install audio driver.
- Step 3 :** Click “VGA (ProSavage) DRIVER” to install graphical driver.
- Step 4 :** Click “USB V2.0 DRIVER ” to install USB V2.0 driver.
- Step 5 :** Click “VIA 6103 LAN DRIVER” to install LAN driver. (Optional)

Drivers Installation

C-Media Audio Configuration Brief Guide

Below is list brief guide of C-Media Audio Configuration. For more detailed information, please refer to user’s manual in the attached CD.

You are able to access the control panel from two places:

- a) The system tray in the right-bottom of your screen. You can click right button of the mouse on it to get an audio-related pop-up menu as follows



- b) In the “Control Panel” (Start=>Setting=>Control Panel), double-click “CMI Audio Config” to open it.

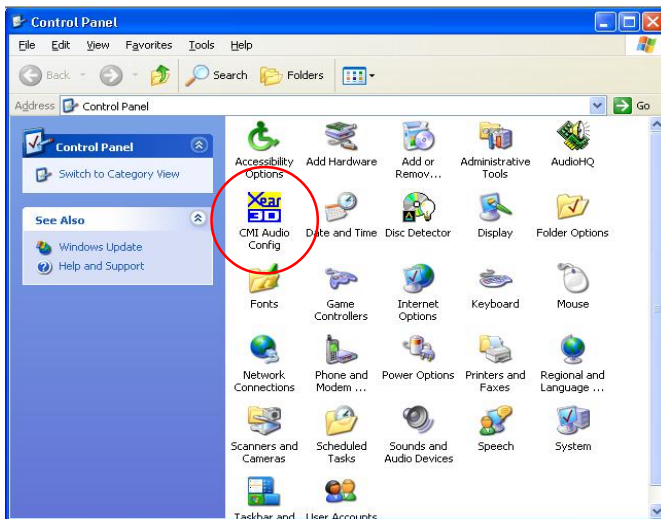

1. Speaker output:

When you open the “3D Audio Configuration”, you will see the default Output tab as the figure below. “Speaker Output” tab collects main setting/options for analog output to speakers.

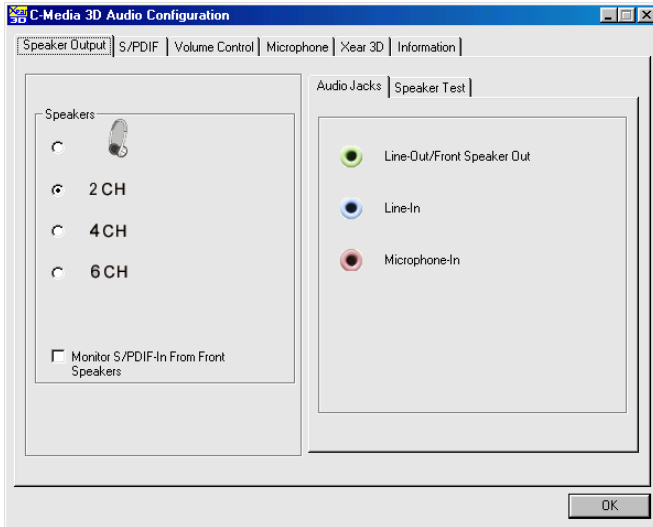

<2 channel mode>

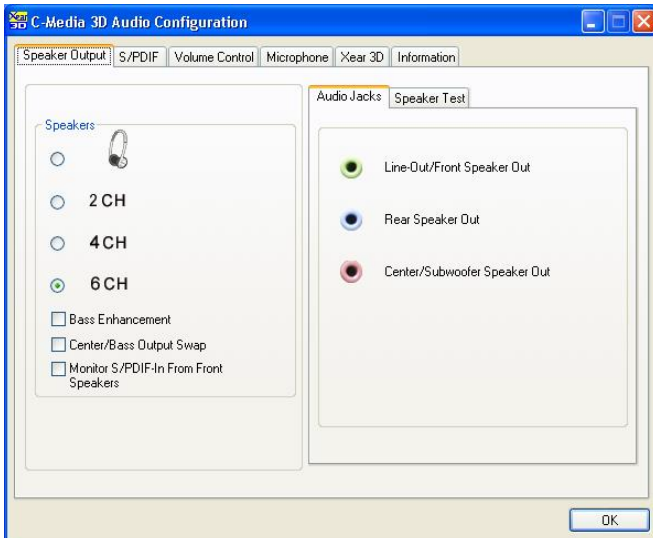

<6 channel mode>

Drivers Installation

2. S/PDIF:

C-Media driver supports digital S/PDIF output (Sony/Philips Digital InterFace, developed by SONY/PHILIPS to provide a low-distortion digital data transfer between audio devices). There may be an optical or coaxial connector for S/PDIF on your system. When you select S/PDIF tab, you will see the setting page as the figure below.

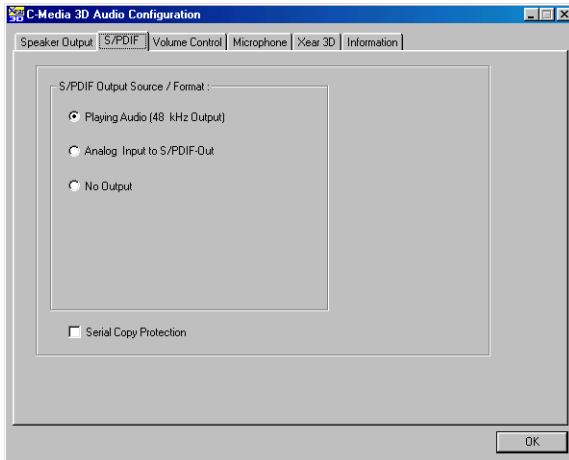

3. Volume Control:

C-Media driver provides the digital volume control for all 6 channels in 3D Audio Configuration. You can regulate each volume to the speaker for current playing digital sound sources. It's not effective for analog input sources.

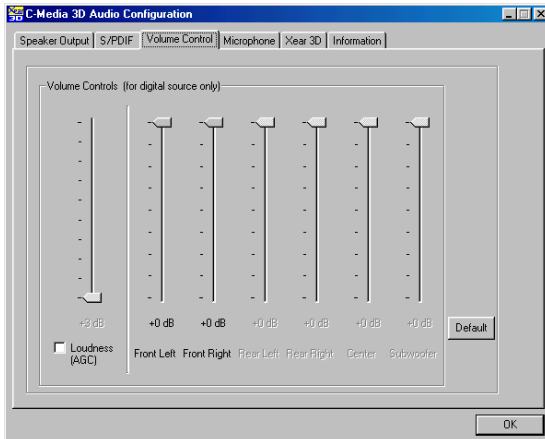

4. Microphone:

C-Media driver provides microphone setting in 3D Audio Configuration directly for more convenience. You can control microphone options in the tab though you can also reach them in Microsoft volume control.

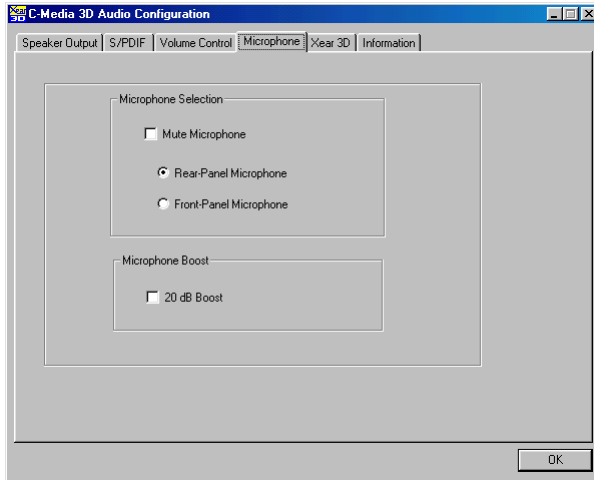

5. Xear 3D:

C-Media driver now supports Xear 3D- 5.1 Virtual SPEAKER SHIFTER and sound effects. Just click the left button in Xear 3D tab and then the new friendly/fancy graphic user interface will pop up.

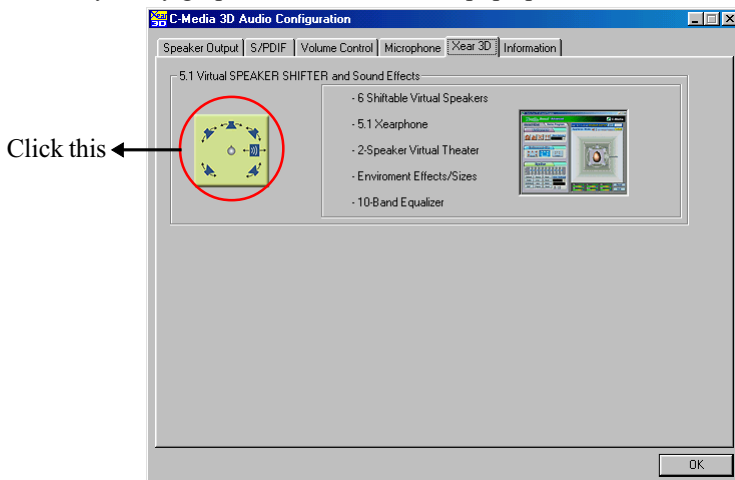

Drivers Installation

- ◆ **Xear 3D - 5.1 Virtual SPEAKER SHIFTER:**

The SPEAKER SHIFTER block provides an advanced, amazing and considerate feature- dynamically adjustable multi-channel sound system no matter what listening appliance you use and what application you are running. You do NOT have to endure unbalanced speaker placement due to spatial limitation. You can enjoy multi-channel surround sound with even an earphone or usual 2 speakers.

- ◆ **Xear 3D - Sound Effect:**

Xear 3D Advanced Program provides another functional block- Sound Effect. You can create a different feeling for your music including 27 Environment Effects, Environment Size & 10-Band Equalizer with 12 pre-set models.



- ◆ **Xear 3D - Multi-channel Music Demo:**

This demo program provides each speaker testing and three 5.1-channel music. You can get feeling about 5.1-channel surround music and use it to test SPEAKER SHIFTER, too. All demo music/sound here will repeat playing if you don't press "Stop" button.



- ◆ **Xear 3D - Play3D Demo:**

Xear 3D Advanced Program also provides interesting Play3D demo programs as below. After installing the program with setup program, you will find the program from the path: "Start->Programs->C-Media 3D Audio->Play3D Demo".



Drivers Installation

6. Information :

There is a C-Media audio-related Information tab in 3D Audio Configuration. You can get a whole picture about the audio chip, driver version, 3D Audio Engine, Microsoft DirectX Version, and Configuration Version itself.

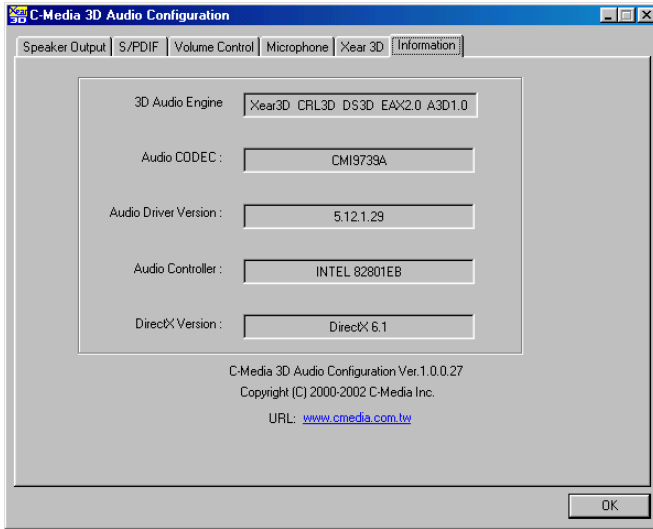

A-1 Update Your System BIOS

Download the xxxxx.EXE file corresponding to your model from our website to an empty directory on your hard disk or floppy. Run the downloaded xxxxx.EXE file and it will self extract. Copy these extracted files to a bootable DOS floppy disk.

Note: The DOS floppy disk should contain NO device drivers or other programs.

1. Type "A:\AWDFLASH and press <Enter> Key.
2. You will see the following setup screen.
3. Please key in the xxxxx.bin BIOS file name.

```
FLASH MEMORY WRITER V7.88
(C)Award Software 2000 All Rights Reserved

For xxxx-W83627-6A69LPA9C-0   DATE: 05/11/2000
Flash Type -
File Name to Program : _____

Error Message:
```

4. If you want to save the previous BIOS data to the diskette, please key in [Y], otherwise please key in [N].

```
FLASH MEMORY WRITER V7.88
(C)Award Software 2000 All Rights Reserved

For xxxx-W83627-6A69LPA9C-0   DATE: 05/11/2000
Flash Type - xxxxx E82802AB /3.3V
File Name to Program : xxxxx.bin

Error Message: Do You Want To Save Bios (Y/N)
```

Appendix

5. Key in File Name to save previous BIOS to file.

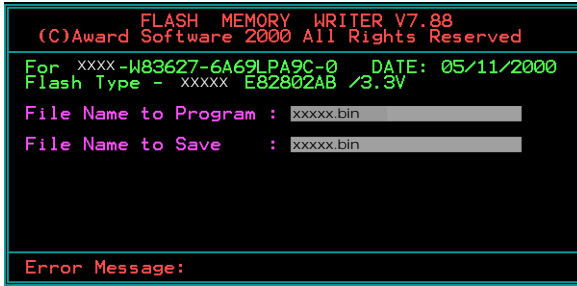

6. To confirm and proceed, please key in [Y] to start the programming.

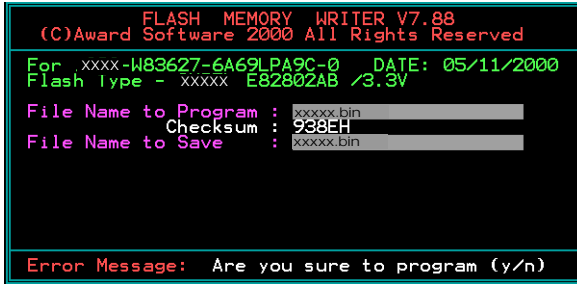

7. The BIOS update is finished.

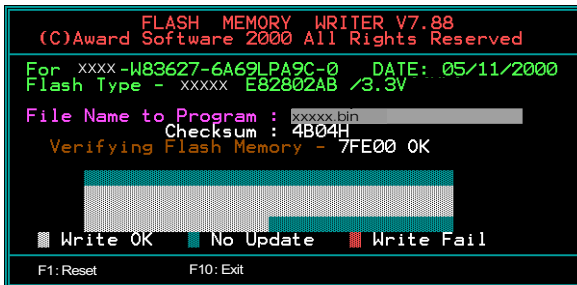

B-1 EEPROM BIOS Remover

Do not remove the BIOS chip, unless instructed by a technician and only with a PLCC IC extractor tool.

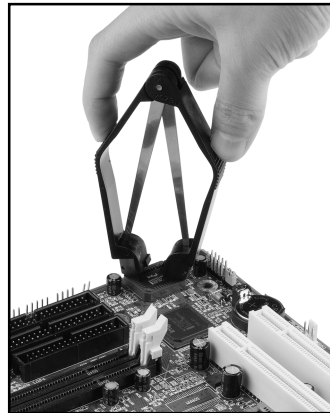
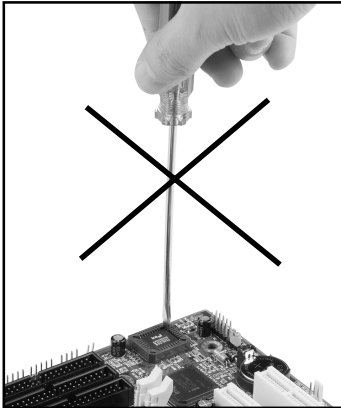

The BIOS socket is fragile may be damaged if an improper method to replace the BIOS chip is applied.

Appendix C

C-1 GHOST 7 Quick User's Guide (Optional)

Installation is very easy. You only need to copy the **Ghost7** folder or **Ghost.exe** to your hard disk.

Main Menu

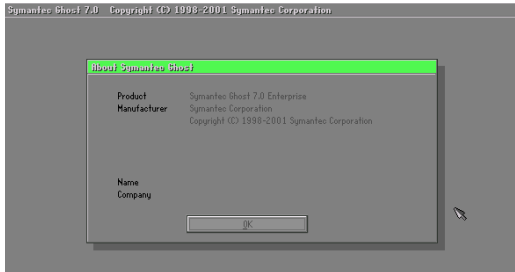

Description of Menu

Ghost clones and backs up **Disk** and **Partition**.

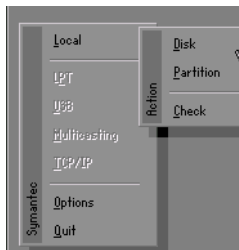

In which **Disk** indicates hard disk options
Partition indicates partition options
Check indicates check options

Disk

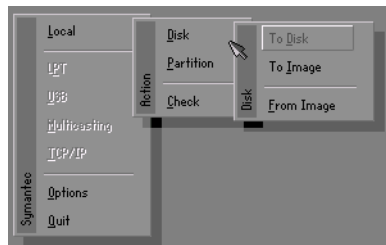

Appendix

There are 3 hard disk functions:

1. Disk To Disk (disk cloning)
2. Disk To Image (disk backup)
3. Disk From Image (restore backup)

Important!

1. To use this function, the system must have at least 2 disks. Press the **Tab** key to move the cursor.
2. When restoring to a destination disk, all data in that disk will be completely destroyed.

Disk To Disk (Disk Cloning)

1. Select the location of the **Source drive**.
2. Select the location of the **Destination drive**.

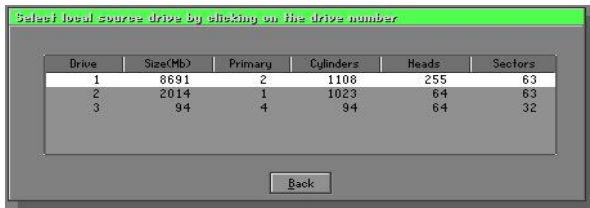

3. When cloning a disk or restoring the backup, set the required partition size as shown in the following figure.



4. Click OK to display the following confirmation screen. Select **Yes** to start.

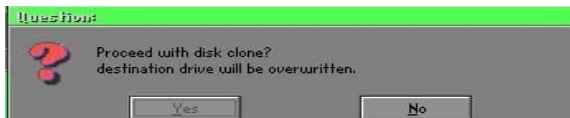

Disk To Image (Disk Backup)

1. Select the location of the Source drive.

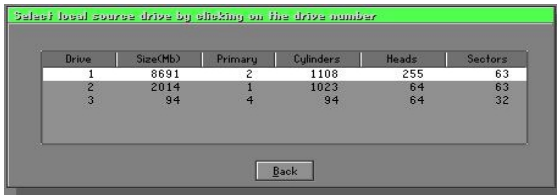

2. Select the location for storing the backup file.

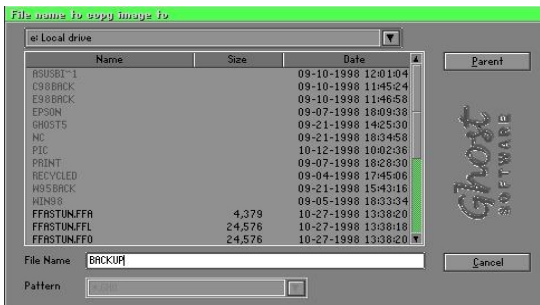

3. Click **OK** to display the following confirmation screen. Select **Yes** to start.

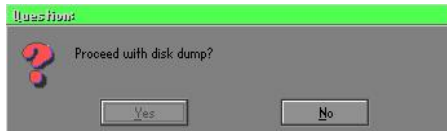

Disk From Image (Restore Backup)

1. Select the Restoring file.

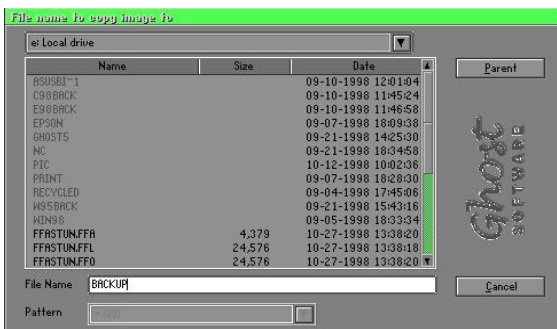

Appendix

2. Select the **Destination drive** of the disk to be restored.

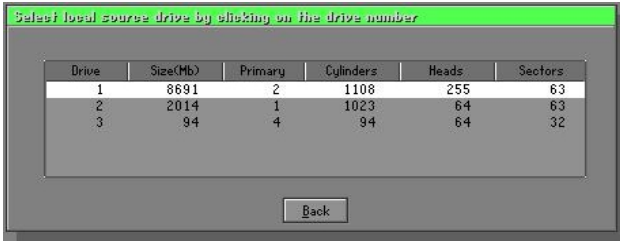

3. When restoring disk backup, set the required partition size as shown in the following figure.

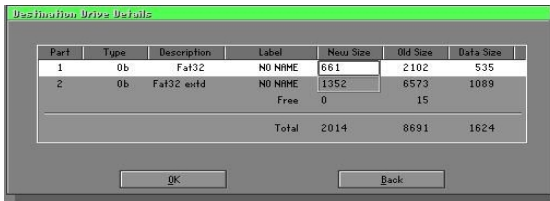

4. Click **OK** to display the following confirmation screen. Select **Yes** to start.

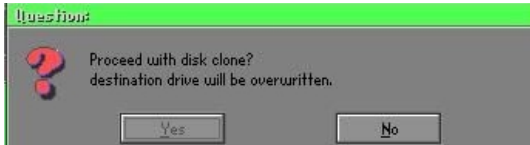

Partition

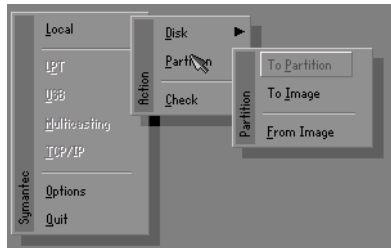

There are 3 partition functions:

1. **Partition To Partition** (partition cloning)
2. **Partition To Image** (partition backup)
3. **Partition From Image** (restore partition)

Partition To Partition (Partition Cloning)

The basic unit for partition cloning is a “partition”. Refer to “disk cloning” for the operating method.

Partition To Image (Partition Backup)

1. Select the disk to be backed up.

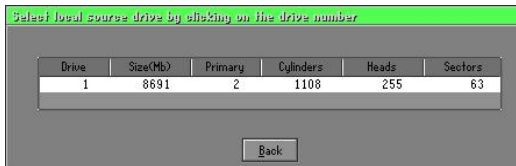

2. Select the first partition to be backed up. This is usually where the operating system and programs are stored.



3. Select the path and file name to store the backup file.

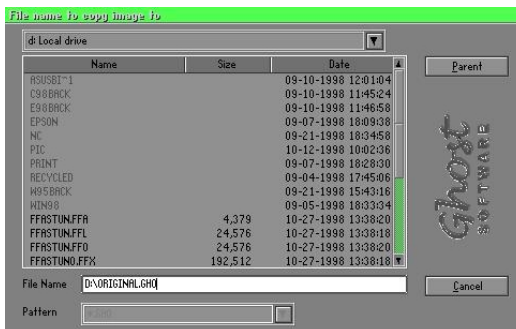

Appendix

- Is the file compressed? There are 3 options:
 - No: do not compress data during backup
 - Fast: Small volume compression
 - High: high ratio compression. File can be compressed to its minimum, but requiring longer execution time.

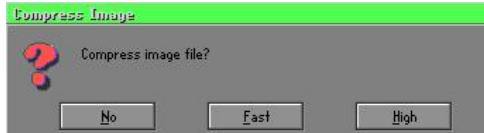

- Select Yes to start performing backup.



Partition From Image (Restore Partition)

- Select the backup file to be restored.

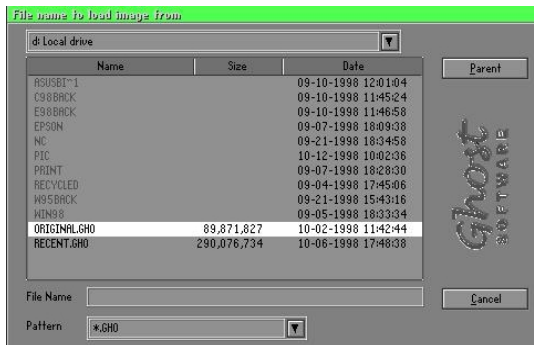

- Select the source partition.

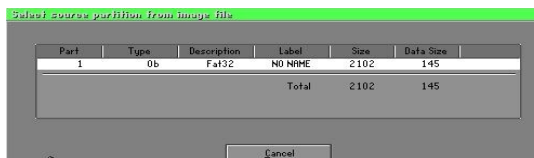

3. Select the disk to be restored.



4. Select the partition to be restored.



5. Select Yes to start restoring.

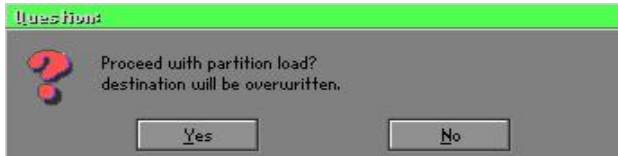

Check

This function is to check possible error caused by defective FAT or track during backup or restoring.

How to Reinstall Windows in 2 Minutes

This chapter guides you how to setup your computer properly and, if necessary, reinstall Windows in 2 minutes. Ghost provides different methods to complete this task. The following two sections explain how to create an emergency Recover Floppy and Recover CD:

Emergency Recover Floppy

Divide a hard disk into two partitions. The first partition is to store the operating system and application programs. The second partition is to back up the operating system and data. The size of the partition can be determined according to the backup requirements. For example, the **Windows** operating system needs 200MB of hard disk space, Plus complete **Office** programs require 360MB. The remaining space can be used to store data.

After installing **Windows**, use **Ghost** to create a backup area for the system and to store the file (Image file) in drive D. The file is named **Original.gho**. Then, create a recover floppy disk containing:

- ◆ Bootable files (Command.com, Io.sys, and MSDOS.SYS)
- ◆ Config.sys (configuration setup file)
- ◆ Autoexec.bat (auto-execution batch file)
- ◆ Ghost.exe (Ghost execution file)

There are two ways to create the content of the recover floppy for restoring:

- (1) To load **Windows** automatically after booting, store the **Autoexec.bat** file with a command line:

```
Ghost.exe clone, mode=pload, src=d:\original.gho:2,dst=1:1 -fx -sure -rb
```

Command Description: Runs the restore function automatically with the Image File. Stored in drive D. After execution, it will exit Ghost and boots the system.

Refer to the [Introducing Ghosts Functions] for details.

- (2) After booting, the screen displays the Menu. Select Backup or Restore: Since the user may install other applications in the future, he/she may alter **Autoexec.bat** file to back up or restore the user-defined Image file as follows:

Backup

Back up Windows and application programs as a file (Recent.gho). Command is:

```
Ghost -clone,mode=pdump,src=1:1,dst=d:\Recent.gho -fx -sure -rb
```

Restore

Restore types include [**General Windows**] and [**Windows and Application Programs**]. If you select [**General Windows**], the system is restored to the general **Windows** operation condition. The command is:

```
Ghost.exe -clone,mode=pload,src=d:\Original.gho,dst=1:1 -fx -sure -rb
```

If you select [**Windows and Application Programs**], the latest backup file (Recent.gho) is restored, skipping the installation and setup of application programs.

For description of related parameters, refer to [**Introducing Ghosts Functions**].

For more information about menu design, refer to Config.sys and Autoexec.bat under /Menu in the CD. You can also create a backup CD containing Ghost.exe and these two files.

Recover CD

The following is a simple guide to create a recover CD:

1. First, create a recover floppy disk contains the following with any copy program such as “Easy CD Create” (Note 2) :

Bootable files (Command.com and Io.sys and MSDOS.SYS)

Config.sys (Configuration setup file)

Autoexec.bat (Auto-execution batch file)

Mscdex.exe (CD-Rom execution file)

Ghost.exe (Ghost execution file)

Oakcdrom.sys (ATAPI CD-ROM compatible driver)

The content of Config.sys is:

```
DEVICE=Oakcdrom.sys /d:idecd001
```

The content of Autoexec.bat includes:

```
MSCDEX.EXE /D:IDECD001 /L:Z
```

```
Ghost.exe clone,mode=load,src=z:\original.gho,dst=1 -sure -rb
```

2. Write the backup image file (original.gho) of the entire hard disk or partition into the recover CD. Use the Recover CD to boot up the system and restore the backup files automatically.

For description of related parameters, refer to **[Introducing Ghosts Functions]**.

Note: For more details about copy the creation program and method to create a recover CD, please refer to the related software and its associated operating manual.

Note: Ghost may be executed in interactive or in batch mode. Most of the Ghost switches are used to assist in batch mode operation. To list switches, type ghost.exe -h.