

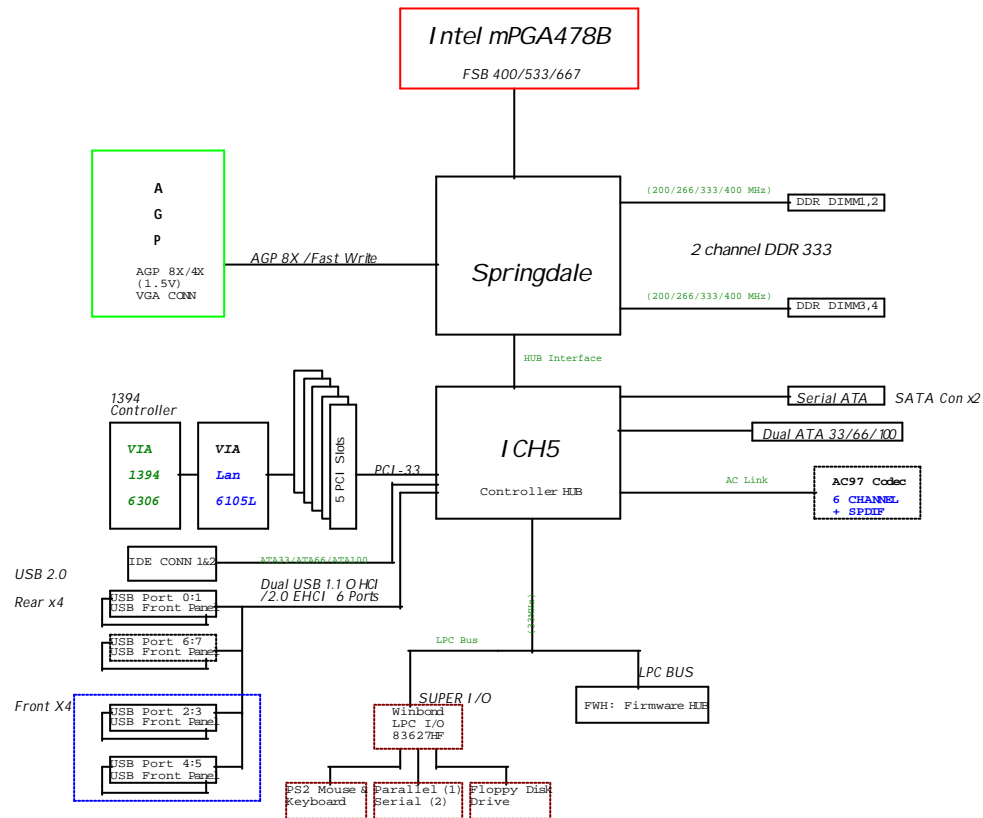

# Block Diagram



+5V : VCC5  
 +3.3V : VCC3  
 +12V : +12V  
 5VSB : VCC5\_SB  
 -12V : -12V  
 +2.55V for DDR : VCC\_DDR  
 1.275V for DDR VTT : VTT\_DDR  
 Dual 3.3V : 3VDUAL  
 1.2V for CPU VID : VCC\_VID  
 1.5V for AGP VI/O : VCC\_AGP  
 Dual 5V : 5VDUAL  
 CPU Vcore : VCCP  
 +5V for analog CODEC : AVDD5  
 1.8V for Broadcom : VCC1.8  
 +12V for 1394 bus power : VCC\_BUS

# GPIO FUNCTION

## ICH5

GPIO Pin	Type	Function	Power well
GPIO 0	I	PREQ#B	MAIN
GPIO 1	I	PREQ#B	MAIN
GPIO 2	I	PIRQ#E	MAIN
GPIO 3	I	PIRQ#F	MAIN
GPIO 4	I	PIRQ#G	MAIN
GPIO 5	I	PIRQ#H	MAIN
GPIO 6	I	GPI6	MAIN
GPIO 7	I	GPI7	MAIN
GPIO 8	I	GPI8	RESUME
GPIO 9	I	OC4#	RESUME
GPIO 10	I	OC5#	RESUME
GPIO 11	I	SIO_SMI#	RESUME
GPIO 12	I	EXTSMI#	RESUME
GPIO 13	I	SIO_PME#	RESUME
GPIO 14	I	OC#6	RESUME
GPIO 15	I	OC#7	RESUME
GPIO 16	O	PGNT#A	MAIN
GPIO 17	O	PGNT#B	MAIN
GPIO 18	O	GPO18	MAIN
GPIO 19	O	BIOS_WP#	MAIN
GPIO 20	O	GPO20	MAIN
GPIO 21	O	GPO21	MAIN
GPIO 22	OD	GPO22	MAIN
GPIO 23	O	GPO23	MAIN
GPIO 24	I/O	GPIO24	RESUME
GPIO 25	I/O	GPIO25	RESUME
GPIO 27	I/O	GPIO27	RESUME
* GPIO 28	I/O	GPIO28	RESUME
GPIO 32	I/O	GPIO32	MAIN
GPIO 33	I/O	GPIO33	MAIN
GPIO 34	I/O	GPIO34	MAIN
GPIO 40	I	PREQ#4	MAIN
GPIO 41	I	GPI41	MAIN
GPIO 48	O	PGNT#4	MAIN
GPIO 49	OD	CPUPWRGD	MAIN

default output  
default output  
default output  
default output  
default output

## FWH

GPIO Pin	Type	Function
GPI 0	I	PD_DET
GPI 1	I	SD_DET
* GPI 2	I	Pull down through 1K ohms (unused)
* GPI 3	I	Pull down through 1K ohms (unused)
* GPI 4	I	Pull down through 1K ohms (unused)

## DDR DIMM Config.

DEVICE	ADDRESS	CLOCK
DIMM 1	1010000B	MCLK_A0/MCLK_A0# MCLK_A1/MCLK_A1# MCLK_A2/MCLK_A2#
DIMM 2	1010001B	MCLK_A3/MCLK_A3# MCLK_A4/MCLK_A4# MCLK_A5/MCLK_A5#

## DDR DIMM Config.

DEVICE	ADDRESS	CLOCK
DIMM 3	1010010B	MCLK_B0/MCLK_B0# MCLK_B1/MCLK_B1# MCLK_B2/MCLK_B2#
DIMM 4	1010011B	MCLK_B3/MCLK_B3# MCLK_B4/MCLK_B4# MCLK_B5/MCLK_B5#

## PCI RESET DEVICE

Signals	Target
PCIRST# ICH5	AGP,FWH,MS-5
PCIRST#1	Springdale,LAN, Super I/O,1394,MS-1
PCIRST#2	PCI slot 1-3 & Mini PCI
HD_RST#	Primary, Scondary IDE

## PCI Clock NC pin : PCI 33MHz(Pin 19 ,20) , 66MHz(Pin 27)

DEVICES	INT#	IDSEL	REQ#/GNT#	CLOCK
Mini PCI 1	INT#A INT#B INT#C INT#D	AD16	PREQ#1 PGNT#1	PCICLK1-Pin-14
PCI SLOT 1	INT#B INT#C INT#D INT#A	AD17	PCI1PREQ#1 PCI1PGNT#1	PCICLK2-Pin-15
PCI SLOT 2	INT#C INT#D INT#A INT#B	AD18	PREQ#3 PGNT#3	MS-1
PCI SLOT 3	INT#D INT#A INT#B INT#C	AD19	PCI3PREQ#3 PCI3PGNT#3	PCICLK4-Pin-9
PCI SLOT 4	INT#G	AD20	PREQ#5 PGNT#5	PCICLK3-Pin-21
Lan 6105L	INT#E	AD25	PREQ#4 PGNT#4	Lan_PCLK-Pin-16
1394	INT#F	AD26	PGNT#2	1394_PCLK-Pin-12
MS-1			PREQ#0 PGNT#0	MS1PCLK-Pin-8

### Micro Star Restricted Secret

Title	Rev
<b>GPIO Spec.</b>	0B
<b>Document Number</b> MS-6747	
MICRO-STAR INT'L 8064, Fsp St, Jung-Ho City, Taipei Hsien, Taiwan http://www.msi.com.tw	Last Revision Date: Tuesday, March 04, 2003 Sheet 3 of 29





# Clock Synthesizer

"Trace less 0.5"

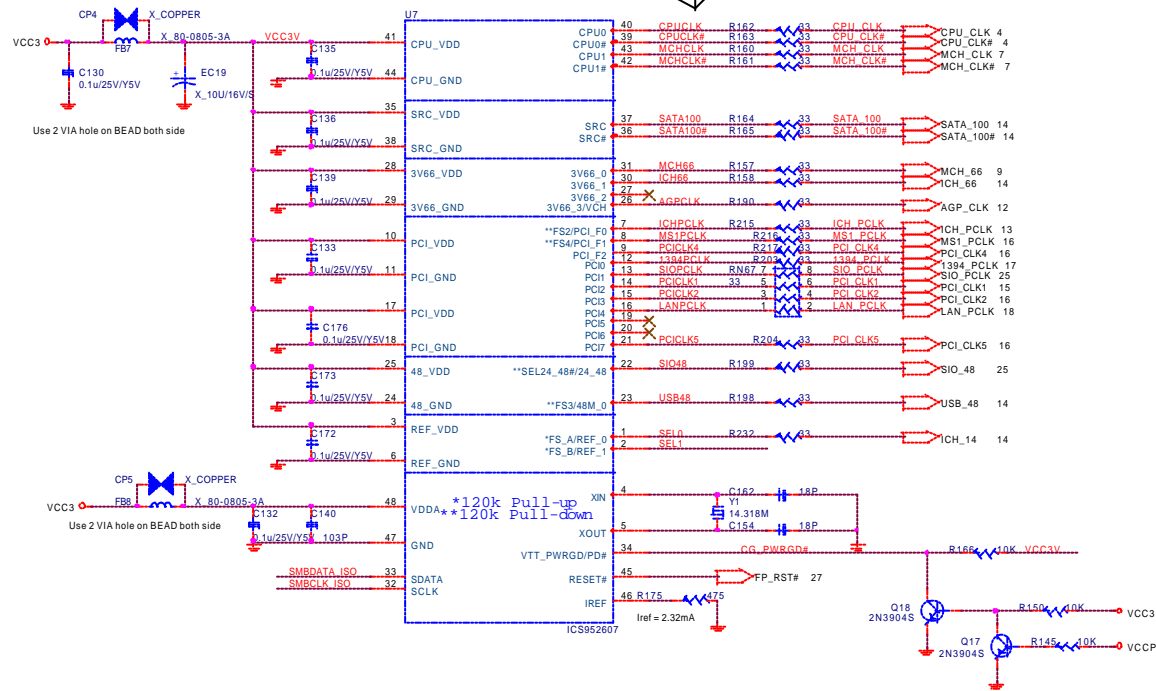

FS_4	FS_3	FS_2	FS_A	FS_B	CPU
0	0	0	BSEL0	BSEL1	133.3
0	0	0	1	1	166.7

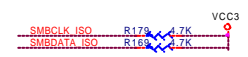
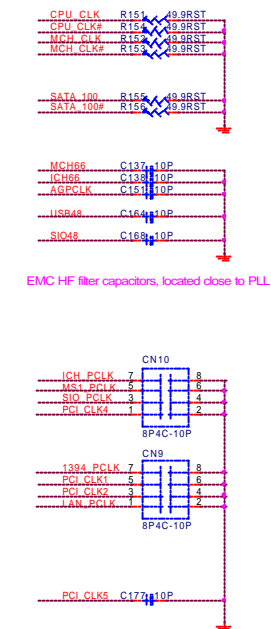
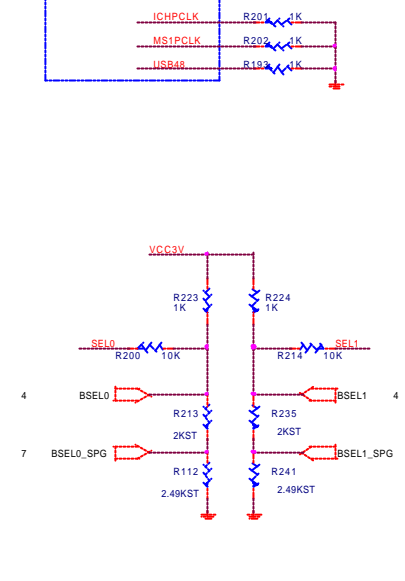

## SMBus Isolation

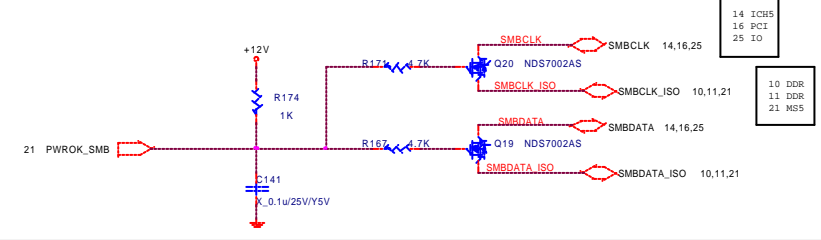

<b>Micro Star Restricted Secret</b>	
<b>Title</b>	Rev
<b>Clock Synthesizer</b>	0B
<b>Document Number</b>	<b>MS-6747</b>
MICRO-STAR INT'L 880/R.F.D. St. Jung-Ho City, Taipei Hsien, Taiwan <a href="http://www.msi.com.tw">http://www.msi.com.tw</a>	Last Revision Date: Tuesday, March 04, 2003 Sheet 6 of 28

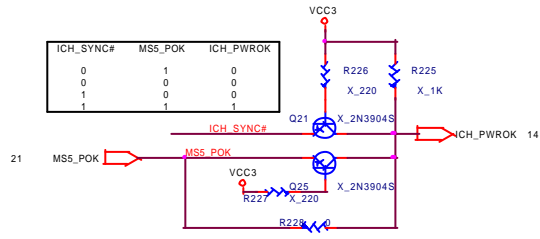
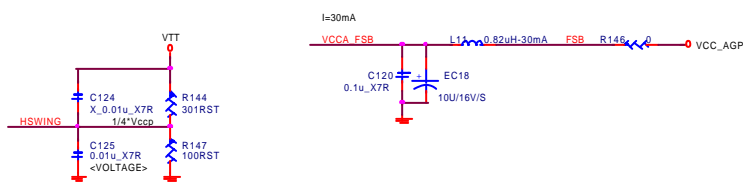
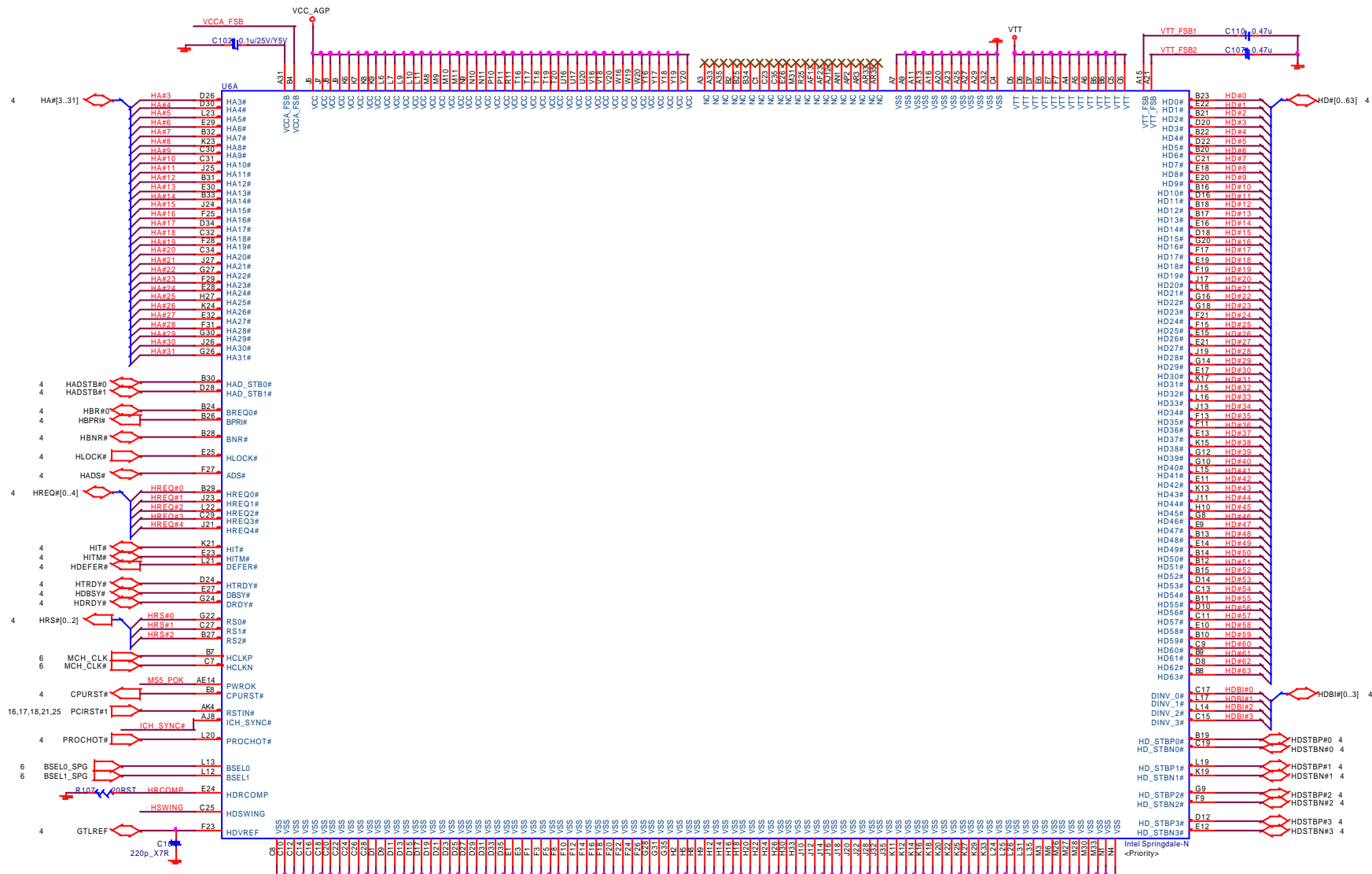

<b>Micro Star Restricted Secret</b>	
<b>Title</b>	Rev
<b>Intel Springdale - CPU</b>	0A
<b>Document Number</b>	<b>MS-6747</b>
MICRO-STAR INT'L 880/8, 4th St. Jung-Ho City, Taipei Hsien, Taiwan <a href="http://www.msi.com.tw">http://www.msi.com.tw</a>	
Last Revision Date: Tuesday, March 04, 2003	
Sheet	7 of 28

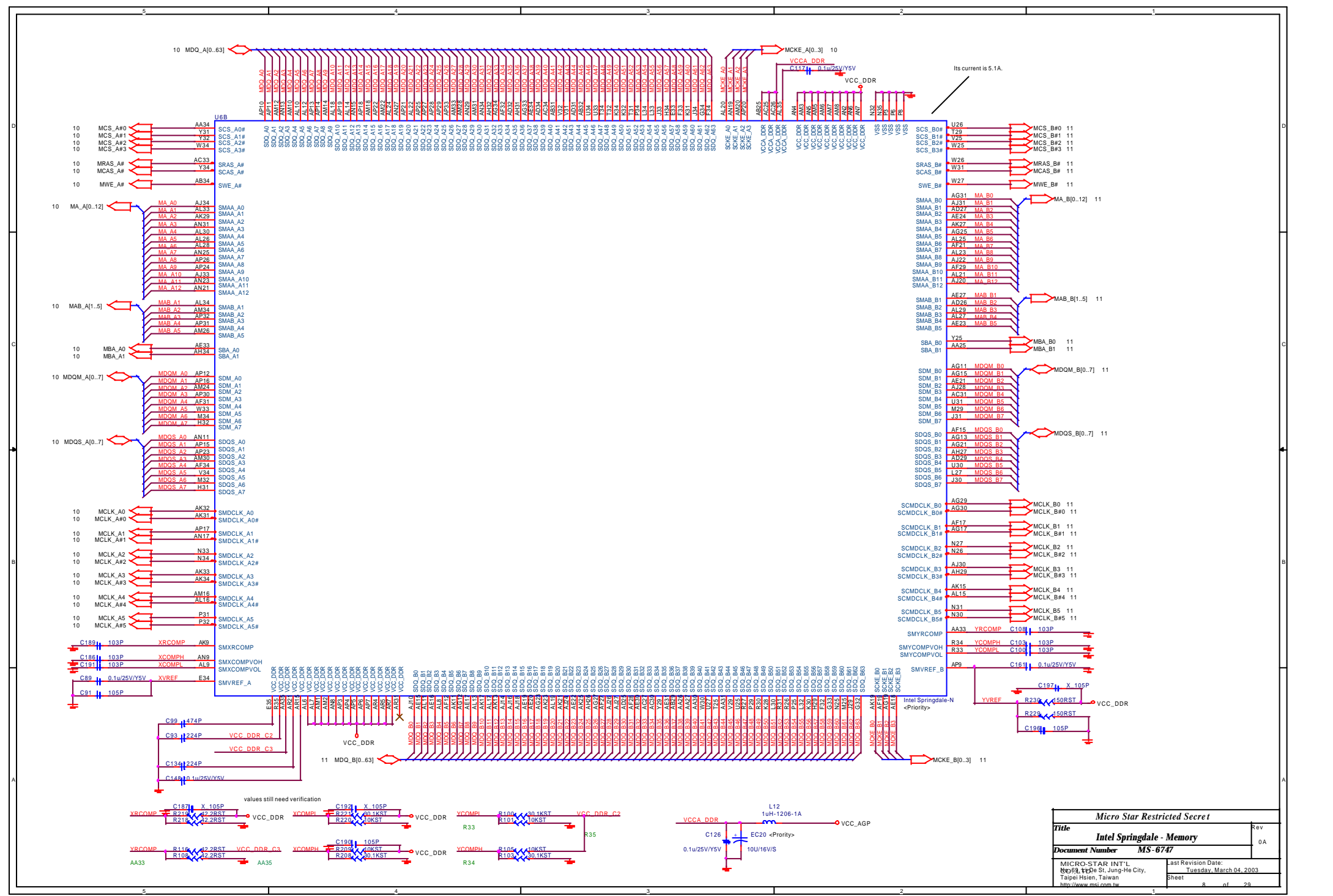

<b>Micro Star Restricted Secret</b>	
<b>Intel Springdale - Memory</b>	
<b>Document Number MS-6747</b>	
MICRO-STAR INT'L 800 R.F. Rd. St. Jung-Ho City, Taipei Hsien, Taiwan <a href="http://www.msi.com.tw">http://www.msi.com.tw</a>	Last Revision Date: Tuesday, March 04, 2003 Sheet 8 of 28



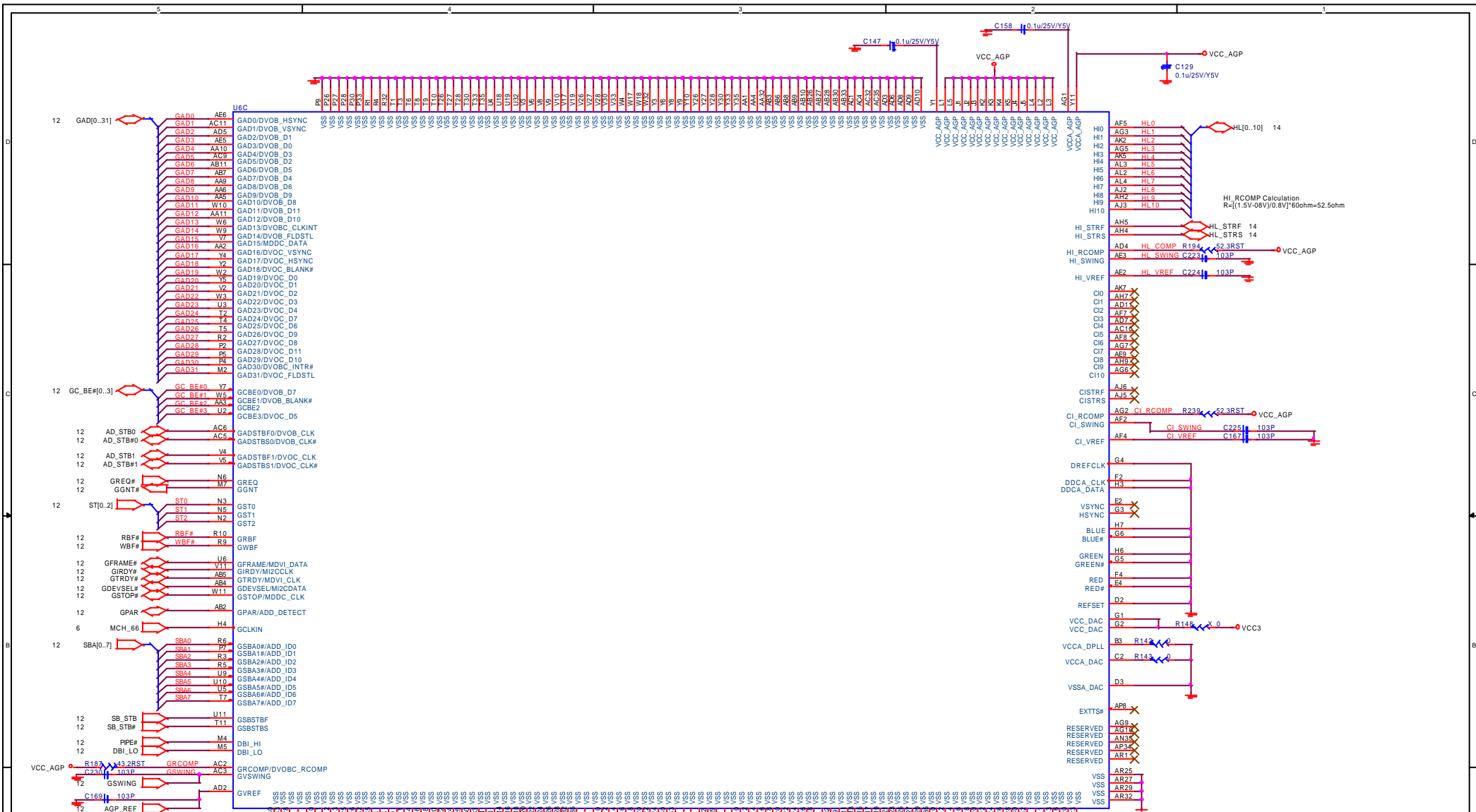

**Springdale Decoupling Capacitors**

All caps trace length is less than 100mils.

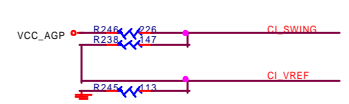
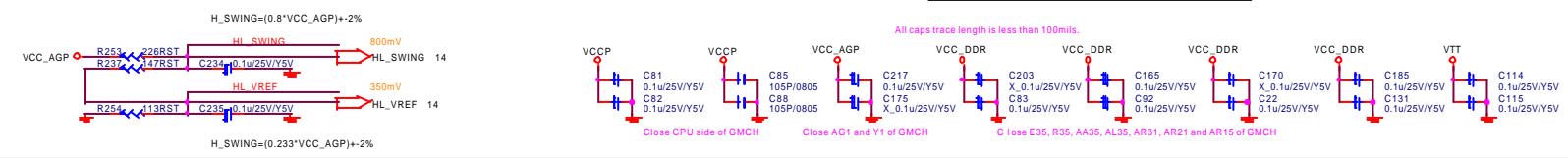

<b>Micro Star Restricted Secret</b>		Rev
<b>Intel Springdale - AGP &amp; LAN</b>		0A
Document Number <b>MS-6747</b>		
MICRO-STAR INT'L 880 R.F.D. St. Jung-Ho City, Taipei Hsien, Taiwan <a href="http://www.msi.com.tw">http://www.msi.com.tw</a>		Last Revision Date: Tuesday, March 04, 2003 Sheet 9 of 29

DDR DIMM1

DDR DIMM2

DDR Terminational Resistors

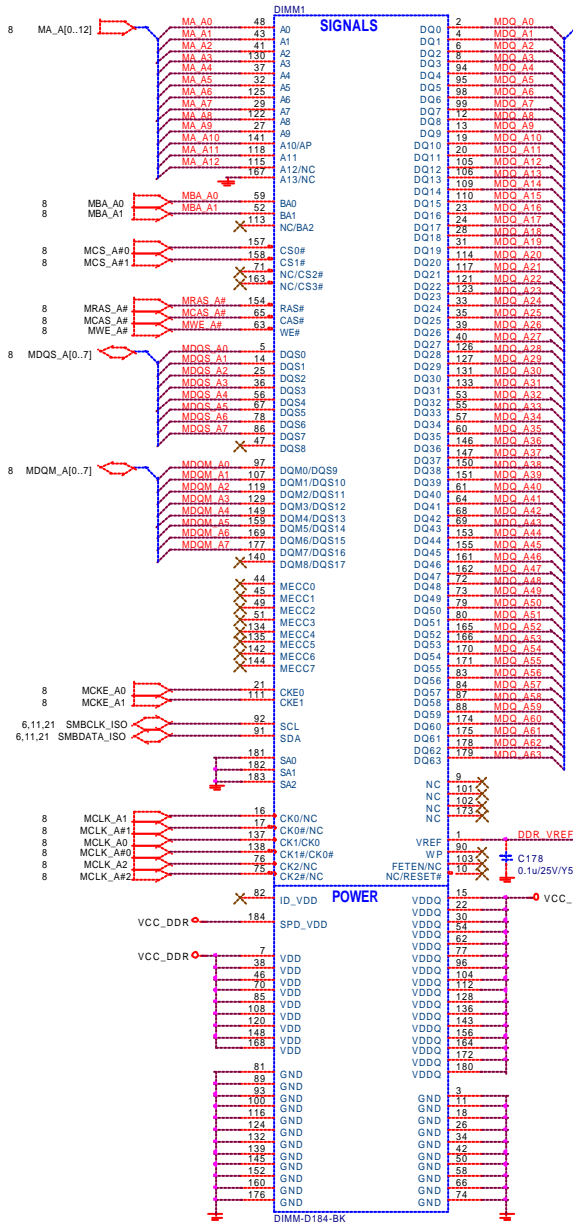

ADDR.=1010000B

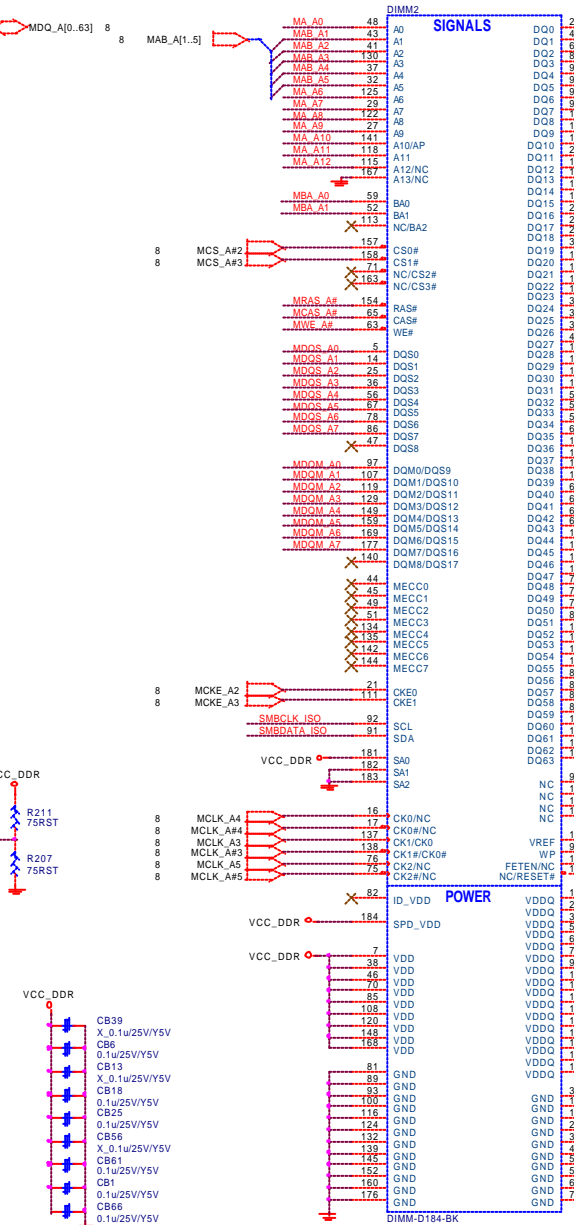

ADDR.=10100001B

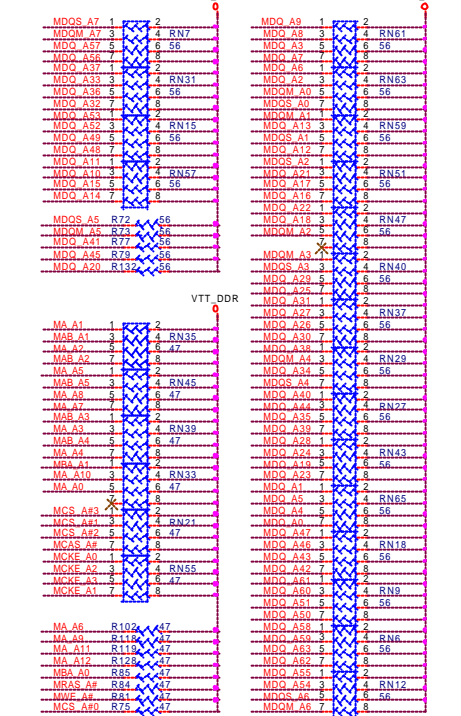

DECOUPLING CAPACITORS

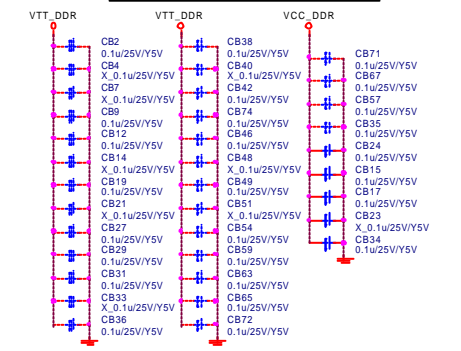

Place these decoupling capacitors close to VTT\_DDR termination resistors. One decoupling capacitor for each R-pack.

Micro Star Restricted Secret	
<b>DDR DIMM 1,2</b>	
Document Number <b>MS-6747</b>	
MIGRO-STAR INT'L 880 R. F. St. Jung-Ho City, Taipei Hsien, Taiwan <a href="http://www.msi.com.tw">http://www.msi.com.tw</a>	
Last Revision Date: Tuesday, March 04, 2003	
Rev	0A
Sheet	10 of 29

# SYSTEM MEMORY

## DDR DIMM3

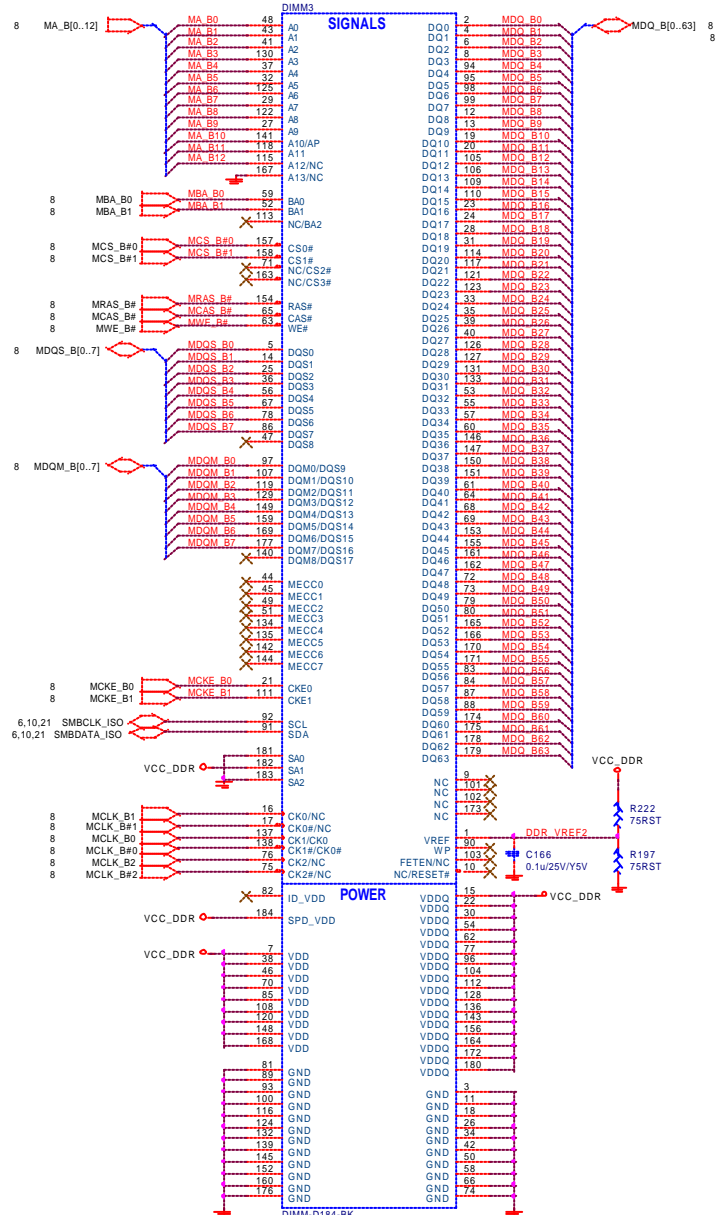

ADDR.=1010010B

## DDR DIMM4

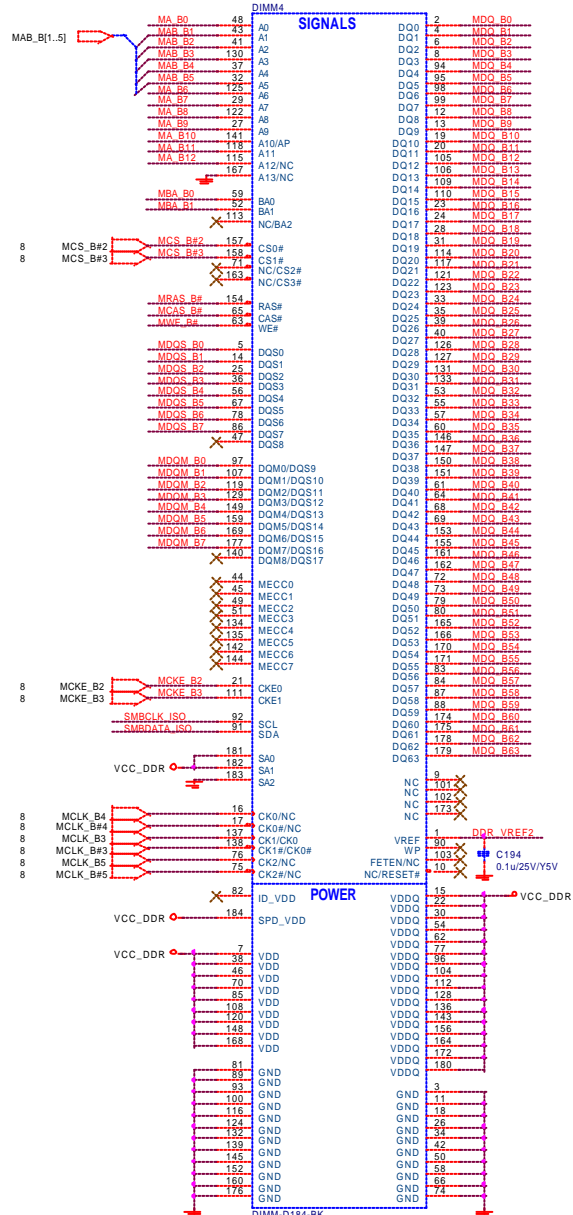

ADDR.=1010011B

## DDR Terminational Resistors

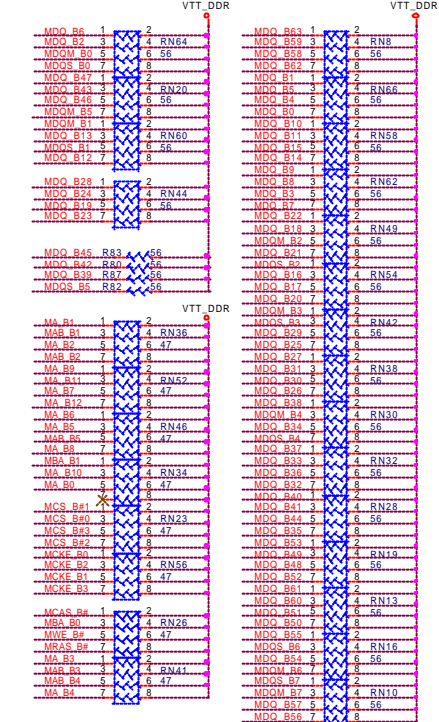

## DECOUPLING CAPACITORS

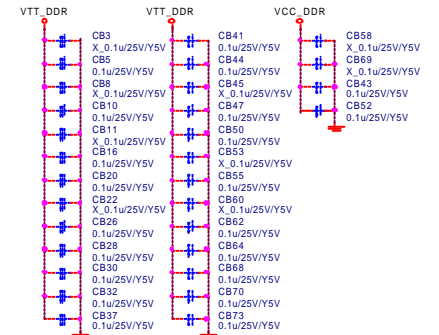

Place these decoupling capacitors close to VTT\_DDR termination resistors. One decoupling capacitor for each R-pack.

<b>Micro Star Restricted Secret</b>		Rev
<b>DDR DIMM 3,4</b>		0A
<b>Document Number MS-6747</b>		
MICRO-STAR INT'L 880 R.F.D. St. Jung-Ho City, Taipei Hsien, Taiwan http://www.msi.com.tw	Issue Revision Date: Tuesday, March 04, 2003	Sheet 11 of 28

B1 == 12V  
 A4 == 12V  
 B4 == 5V

**AGP 1.5V 4X/8X SLOT(AGP VER:3.0)**

VCC5 = 60mils trace / 15mils space

AGP Slot Imax  
 VCC3 2.0A  
 VCC5 6.0A  
 VCC12 1.0A  
 VCC3 2.0A  
 VCC3\_SB 0.75A

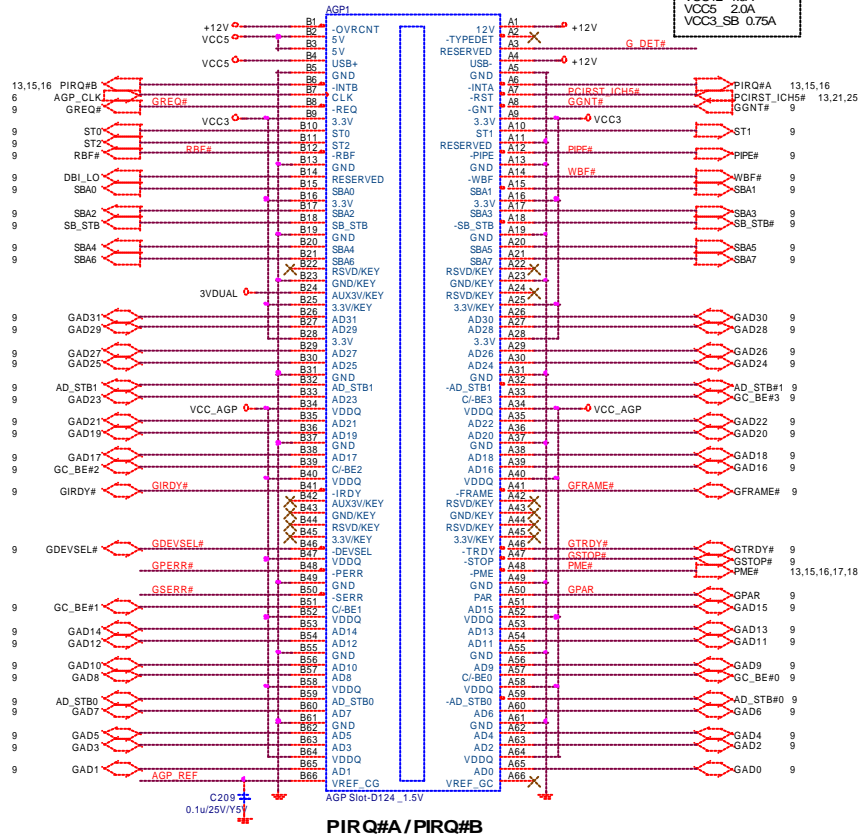

**Springdale Reference & Swing Voltage Circuit**

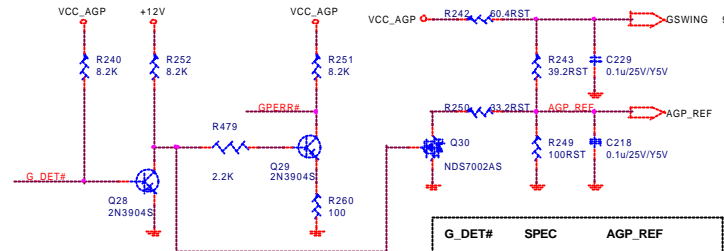

G_DET#	SPEC	AGP_REF
FLOATING	AGP2.0	0.75V~0.55V
LOW	AGP3.0	0.35V~0.55V

**AGP TERMINATION RESISTORS**



**AGP SLOT DECOUPLING CAPACITORS**

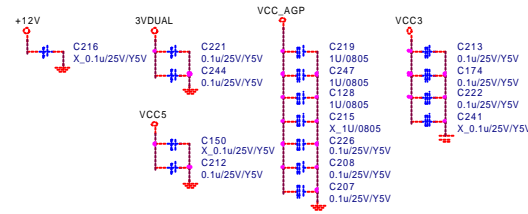

Micro Star Restricted Secret		
Title	AGP SLOT	Rev
Document Number	MS-6728	0A
MICRO-STAR INT'L 880/R. 10th St. Jung-Ho City, Taipei Hsien, Taiwan http://www.msi.com.tw		Last Revision Date: Tuesday, March 04, 2003 Sheet
		12 of 28





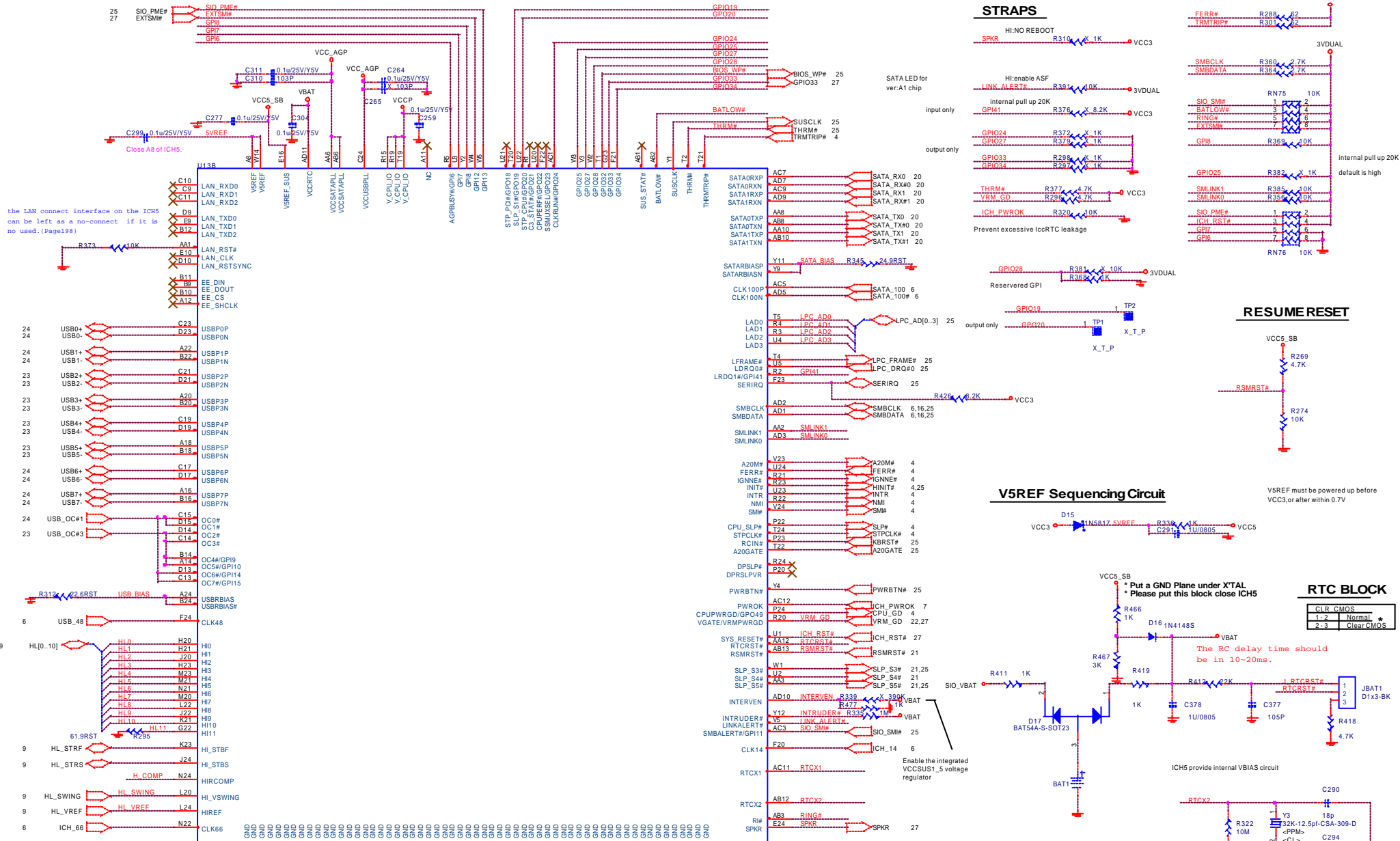

the LAN connect interface on the ICH5 can be left as a no-connect if it is not used. (Page198)

### STRAPS

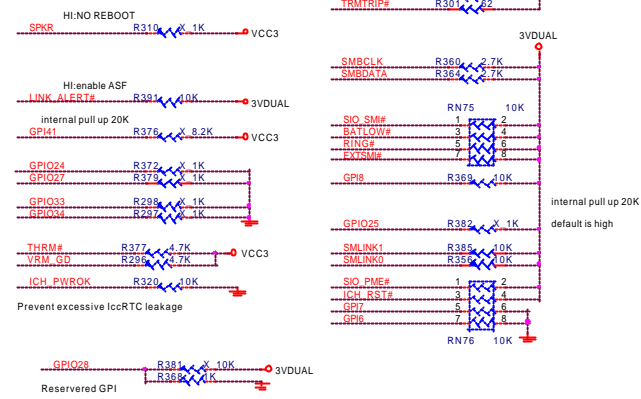

### RESUME RESET

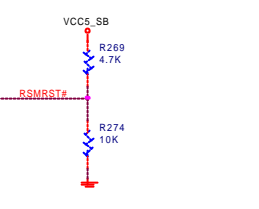

### V5REF Sequencing Circuit

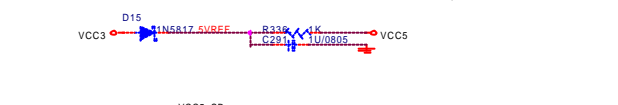

### RTC BLOCK

CLR_CMOS	1-2	Normal
	2-3	Clear CMOS

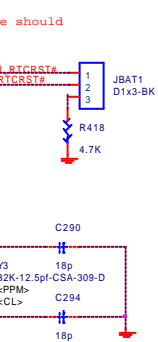

<b>Micro Star Restricted Secret</b>		Rev
<b>Intel ICH5 - Other signals</b>		0A
<b>Document Number</b>	<b>MS-6747</b>	
MICRO-STAR INT'L 880/Rd, 12th St, Jung-Ho City, Taipei Hsien, Taiwan <a href="http://www.msi.com.tw">http://www.msi.com.tw</a>	Last Revision Date: Tuesday, March 04, 2003	Sheet 14 of 28

H\_COMP R299 62.3RST VCC\_AGP  
Impedance is equal 60ohm.  
HL\_SWING C269 0.01u X7R  
HL\_VREF C264 0.01u X7R

**IDSEL = AD16**  
**MASTER = PREQ#1/PGNT#1**  
**PIRO#A CLK-gen-Pin14**  
**PCI SLOT 1 (PCI VER: 2.2 COMPLY)**

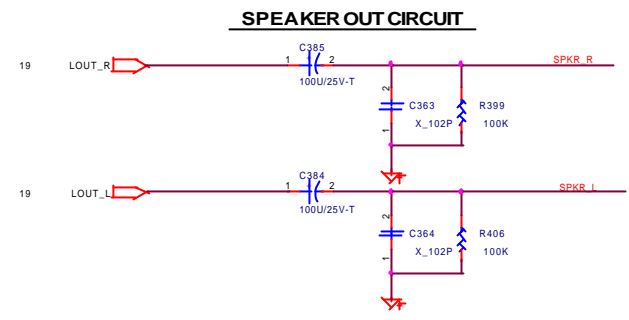
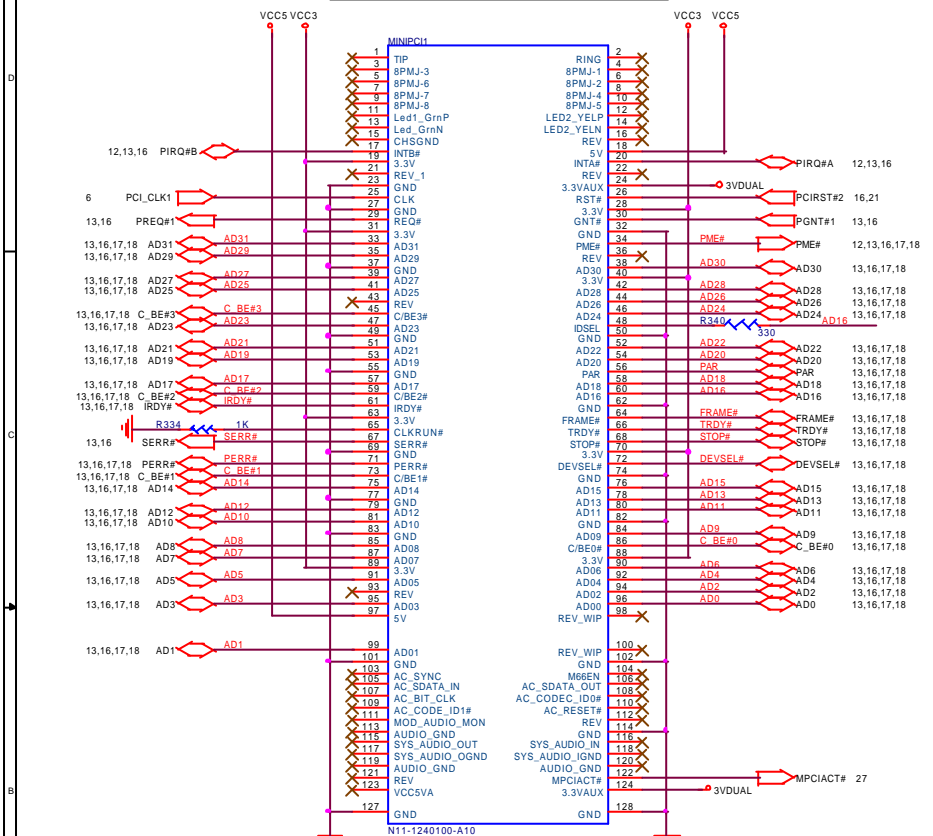

**Audio Connector**  
 N54-13F0011-K06  
 CN-IOC-JACKx3+PHONE-D13

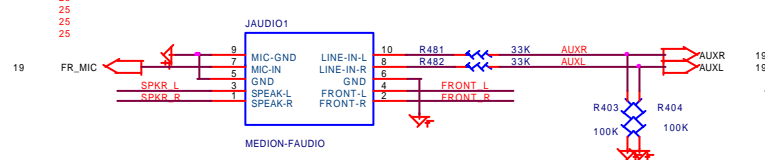
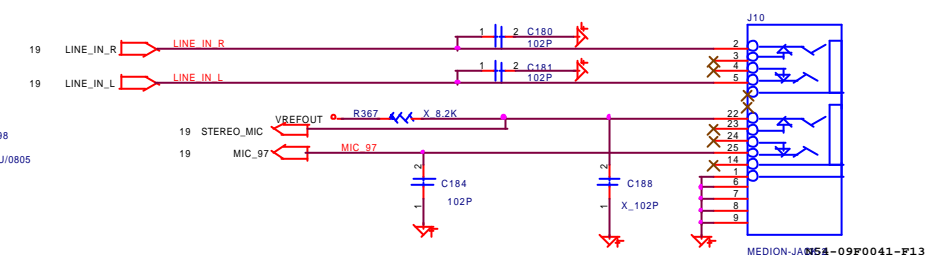
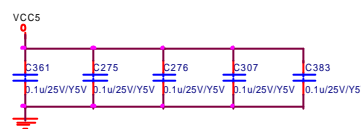
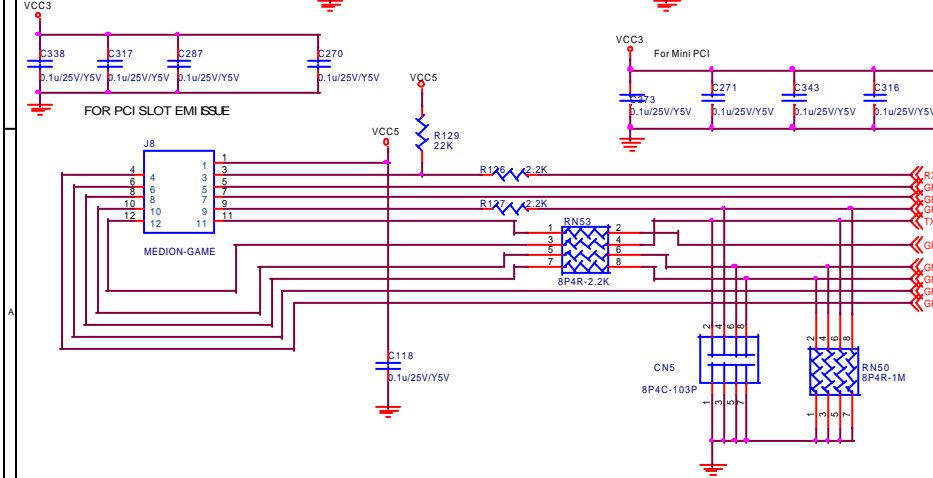
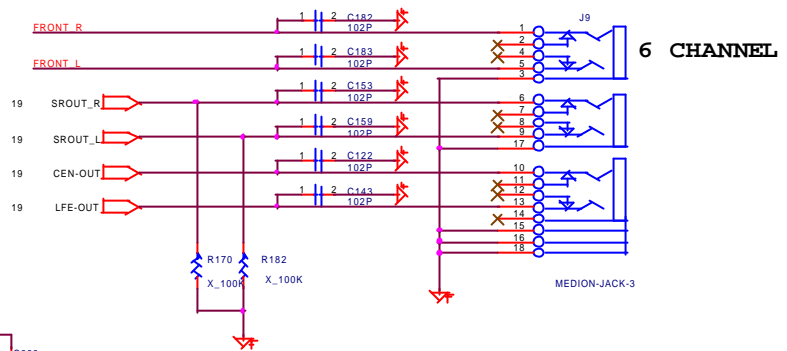

<b>Micro Star Restricted Secret</b>	
<b>Mini PCI &amp; Audio conn.</b>	
<b>Document Number MS-6747</b>	
MICRO-STAR INT'L 880 R.F. Rd. St. Jung-Ho City, Taipei Hsien, Taiwan <a href="http://www.msi.com.tw">http://www.msi.com.tw</a>	Last Revision Date: Tuesday, March 04, 2003 Sheet 15 of 28





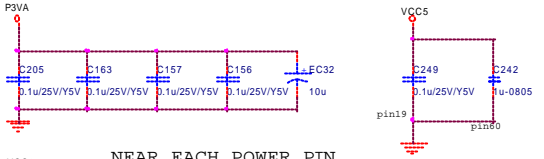
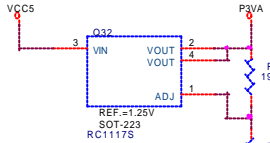
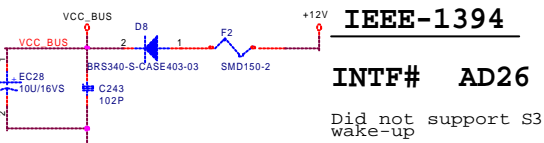

13,15,16,18 AD[31..0] AD[31..0]

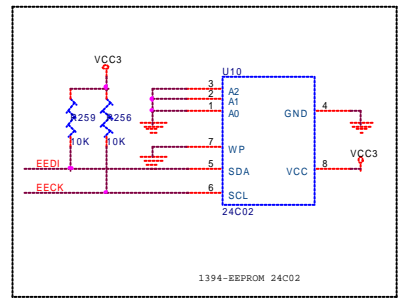
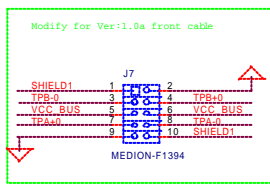
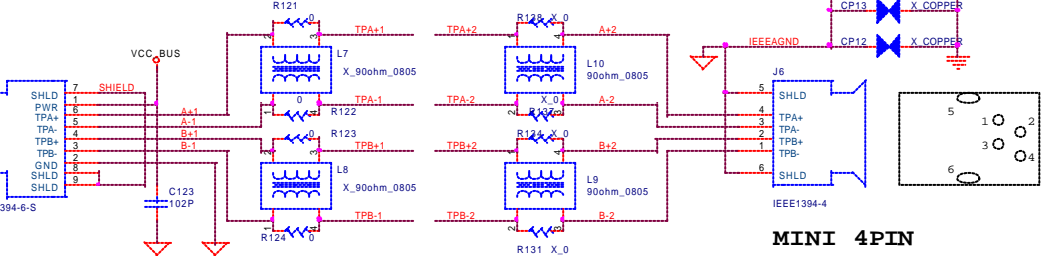
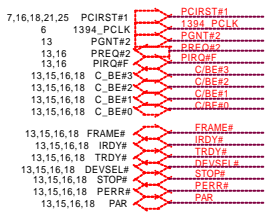
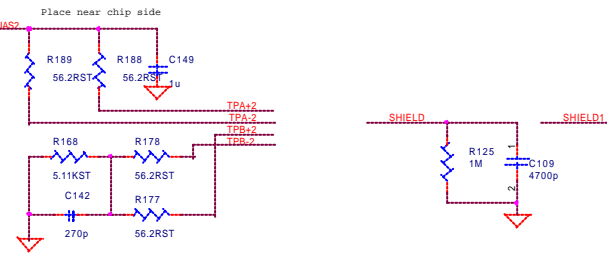
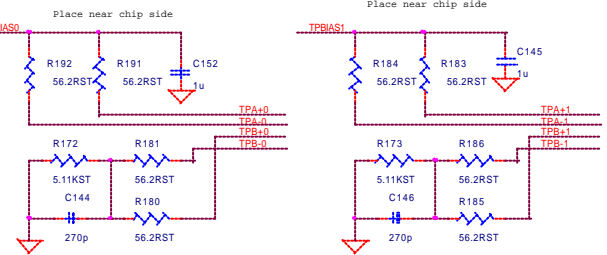
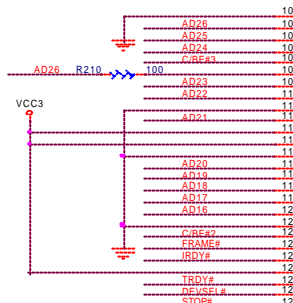
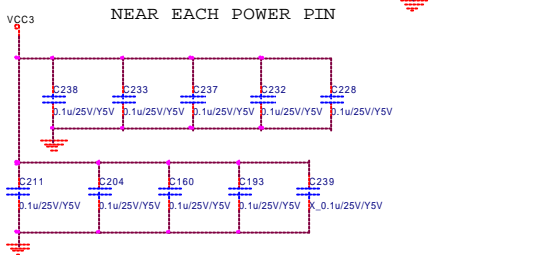
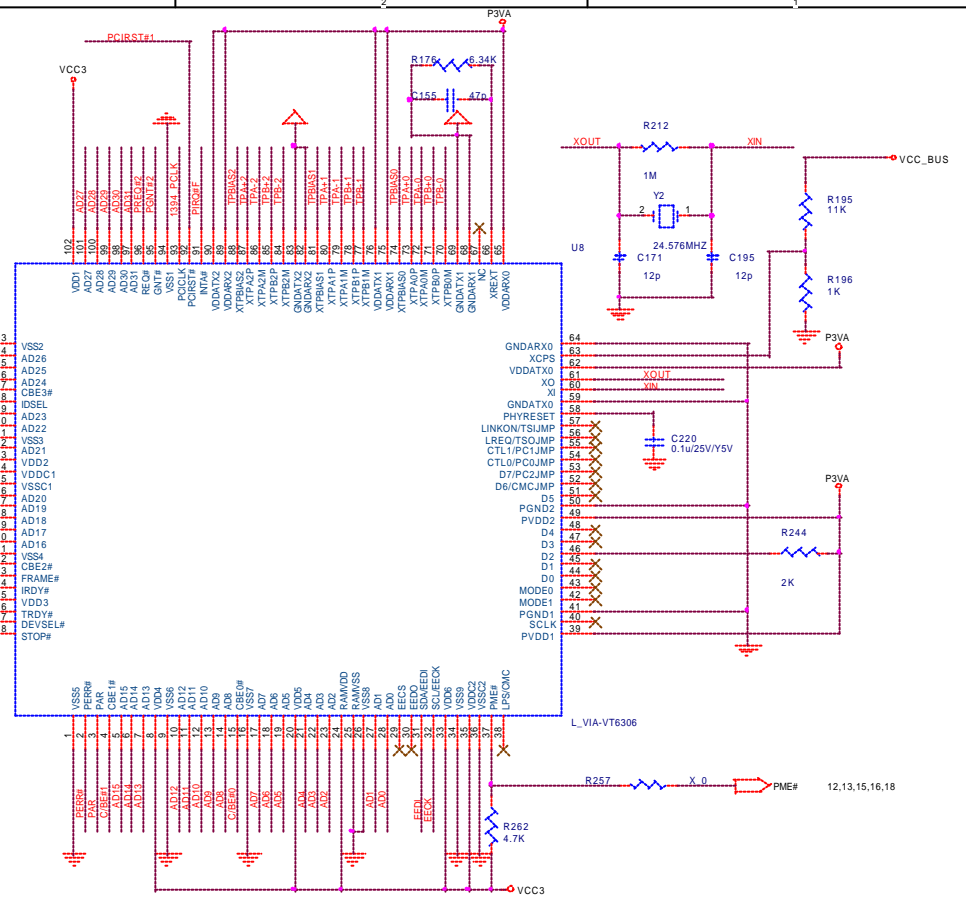

<b>Micro Star Restricted Secret</b>		Rev
<b>IEEE 1394(NEC)</b>		100
<b>Document Number</b> MS-6747		
MICRO-STAR INT'L 880 R.F.D. St. Jung-Ho City, Taipei Hsien, Taiwan <a href="http://www.msi.com.tw">http://www.msi.com.tw</a>	Last Revision Date: Tuesday, March 04, 2003	Sheet 17 of 28

# Lan - VIA6105

REQ#/GNT#4  
INTE# AD25

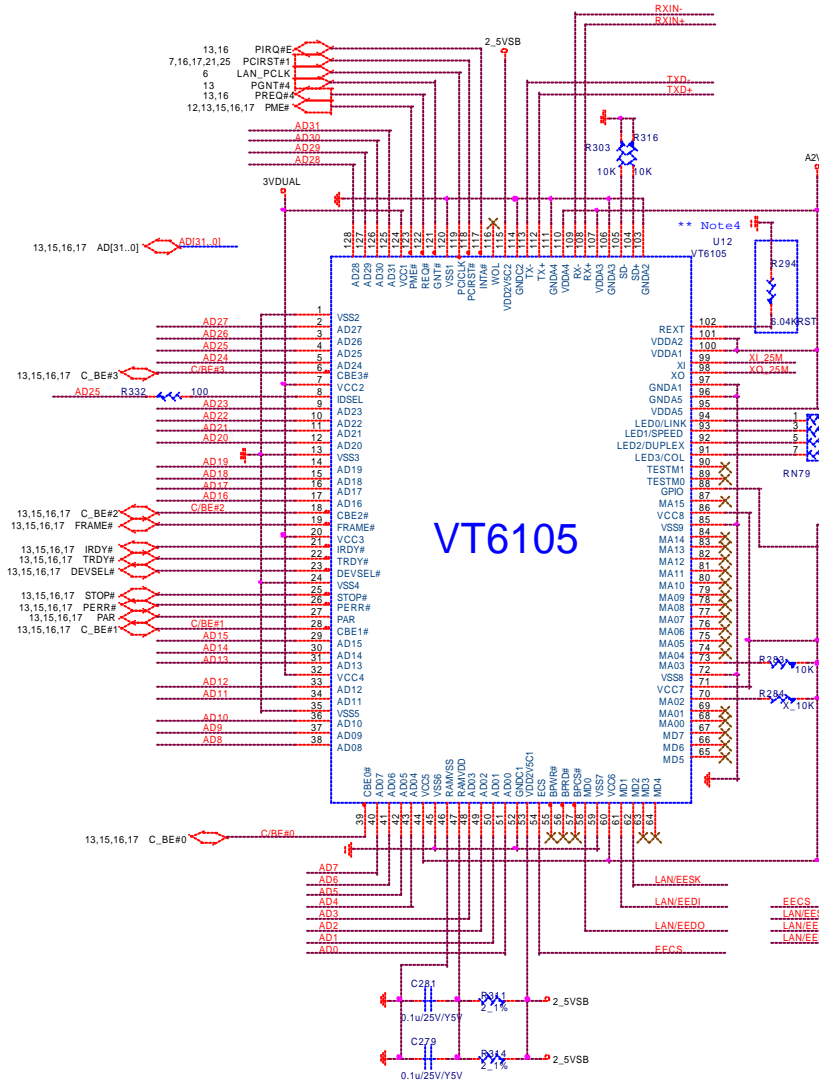
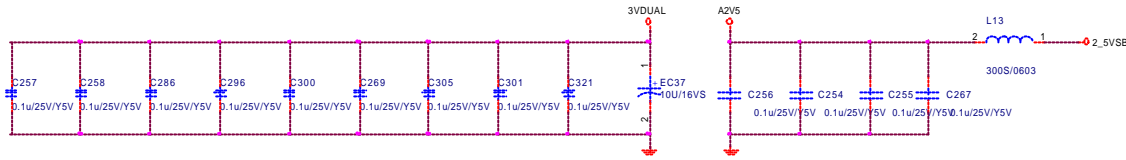

40 : 6 : 8 : 6 : 40 mil

\*\* Note 4

\*\* Note 5

CNT, I/o-conn/assembly, rj45+usb\*2+led

\*2/20pin, W transformer

DIP/(rj45)/M(usb)/2.54(rj45)/2(usb)/2.54(led), black, P-B/PBT, led on the top

(led led L:YL, R:GR), plating: usb/rj45 30u-in, PIN=3.3

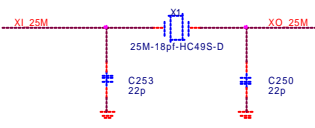
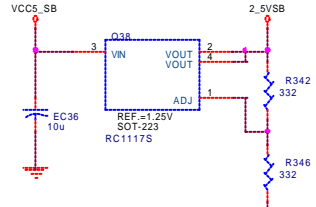
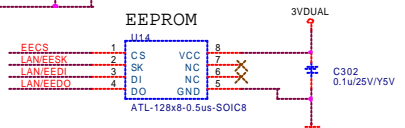
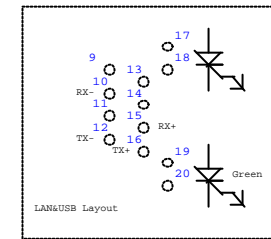
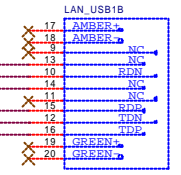
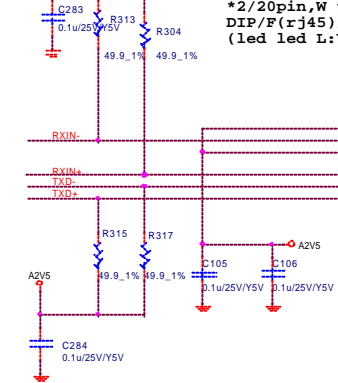

Micro Star Restricted Secret	
Title	Rev
Broadcom 4401	0A
Document Number	MS-6747
MICRO-STAR INT'L 800/R. Rd. St. Jung-Ho City, Taipei Hsien, Taiwan <a href="http://www.msi.com.tw">http://www.msi.com.tw</a>	Last Revision Date: Tuesday, March 04, 2003 Sheet 18 of 28

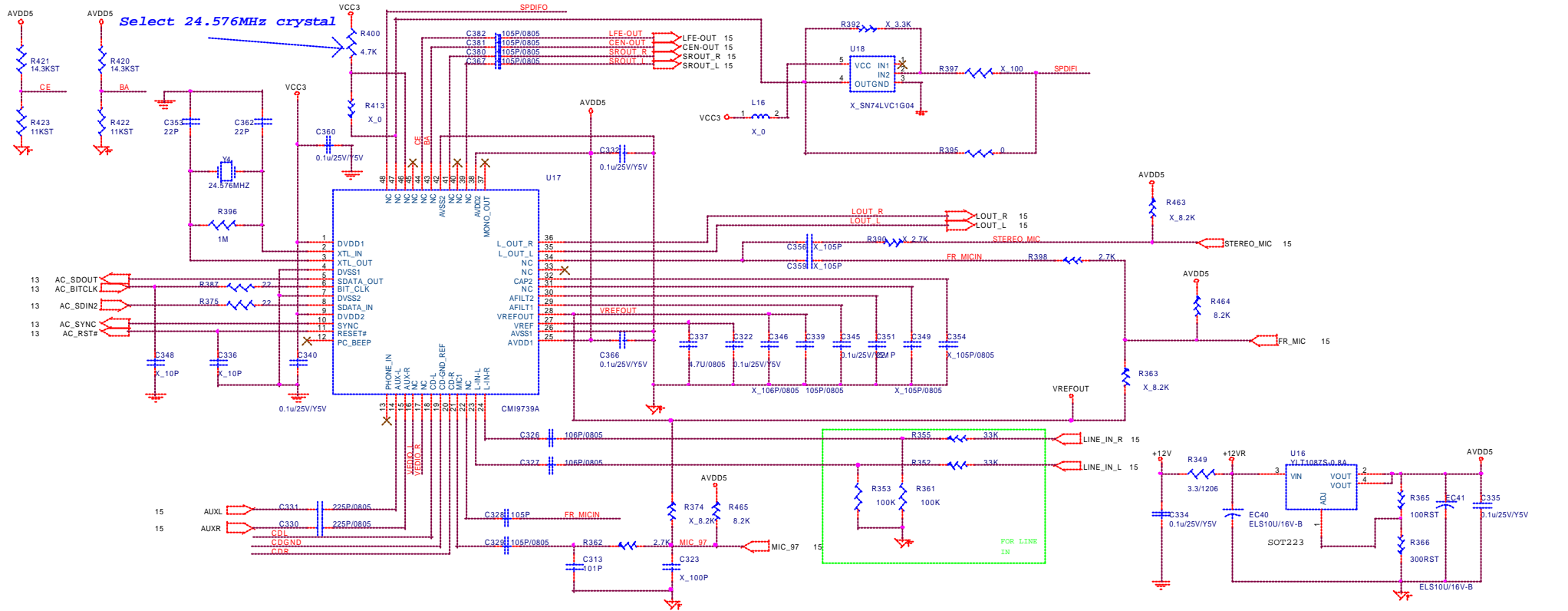

CMI9739A Pin21 == MIC1  
 Pin22 == MIC2  
 Pin34 == NC

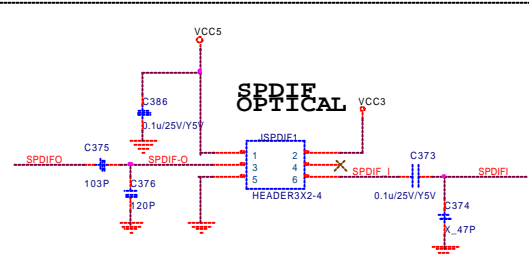
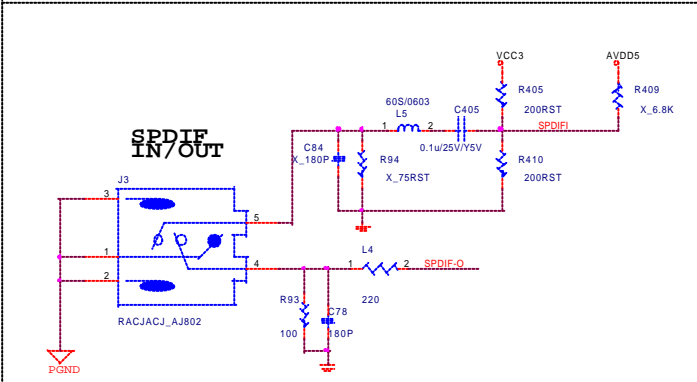
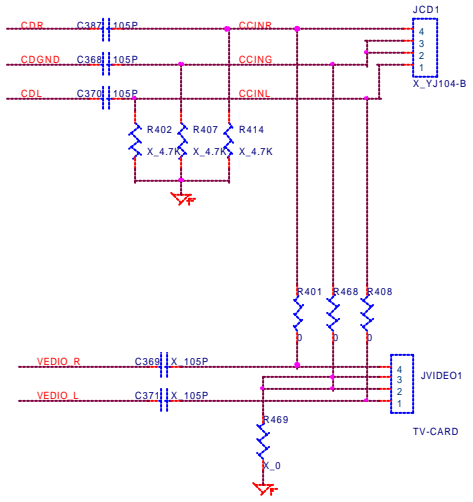

<b>Micro Star Restricted Secret</b>		
<b>Retek 650</b>		Rev
<b>Document Number MS-6747</b>		0A
MICRO-STAR INT'L 880-RFED St. Jung-Ho City, Taipei Hsien, Taiwan <a href="http://www.msi.com.tw">http://www.msi.com.tw</a>		Last Revision Date: Tuesday, March 04, 2003 Sheet 18 of 28

# ATA 33/66/100 Connector

## PRIMARY IDE BLOCK

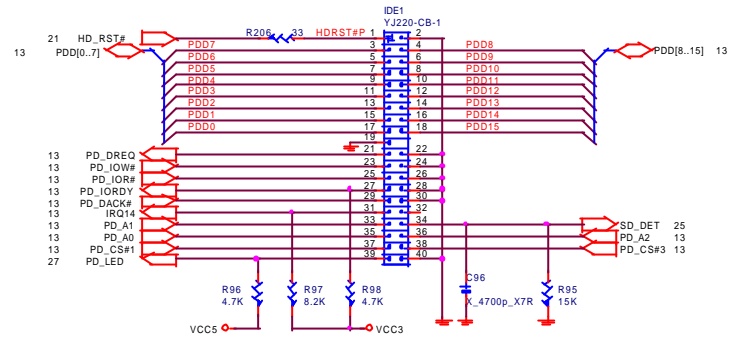

## SECONDARY IDE BLOCK

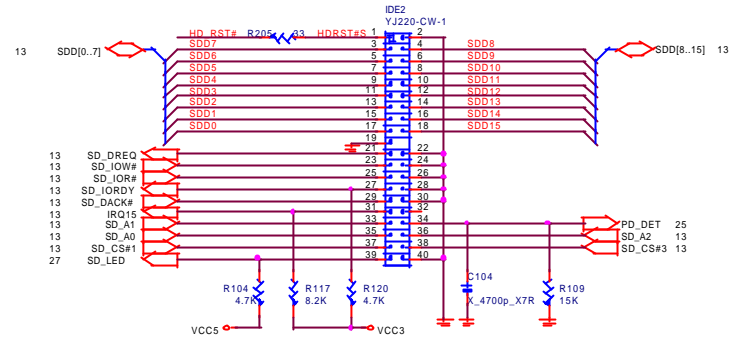

## SERIAL ATA CONNECTOR BLOCK

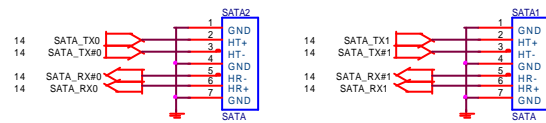

## Optics Orientation Holes

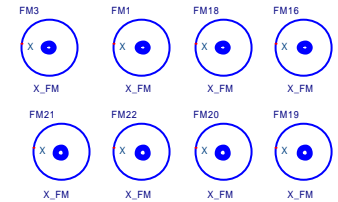
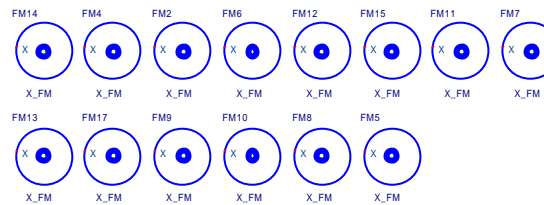

## Mounting Holes

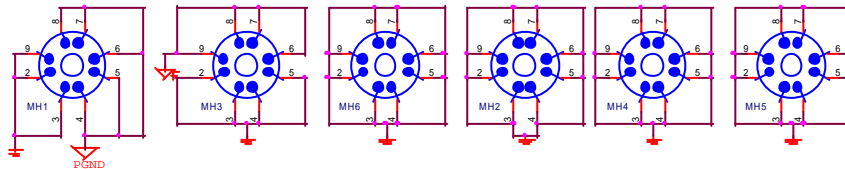

## Simulation

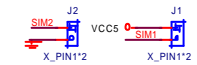

<b>Micro Star Restricted Secret</b>	
<b>Title</b>	Rev
<b>ATA 33/66/100 Connector</b>	0A
<b>Document Number</b>	<b>MS-6747</b>
MICRO-STAR INT'L 880/R. Rd. St. Jung-Ho City, Taipei Hsien, Taiwan <a href="http://www.msi.com.tw">http://www.msi.com.tw</a>	Last Revision Date: Tuesday, March 04, 2003 Sheet 20 of 28

# ACPI Controller

1.7V@250mA

Power	S0	S3	S5
VCC3_SB	Main	Standby	Standby
VCC5_STR	Main	Standby	OV
MEM_STR	Main	Standby	OV

SELO	5VUSB
H	2 MOSFET
L	1 MOSFET

\*\*S50# pin function(Hi level = 5V)  
same as 5VUSB(Hi level = 12V)  
5VUSB USE 2 MOSFET

\*\*INPUT 2 AND 3 MUST BE HI LEVEL WHEN USE  
OUTPUT 1 AND 2 FOR GPIO FUNCTION

Near 302E

## DDR VTT Power

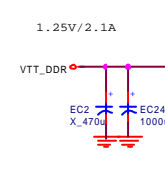

SELI	VRAM	VRAM_2.5
H	3.3VDUAL	2.5V
TRI-STATE	3.3VSB	2.5V
L	3.3VSTR	1.25V

FOR 3VSB OR 3VSTR  
SETTING BY SEL1

Pin 15,19,22,32 Must  
reserve capacitor.

ICH5 300mA  
PCI 375+20+20=415mA  
VCC3\_SB 715mA

\*\* SETTING 3VSTR THEN VRAM\_2.5  
BECOME TO 1.25 VREF

## 5V DUAL Power

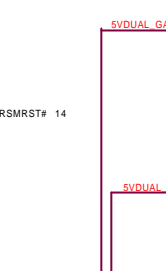

## VCC VID/VID\_GOOD



## DDR 2.5V Power

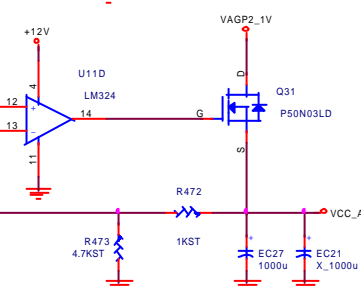
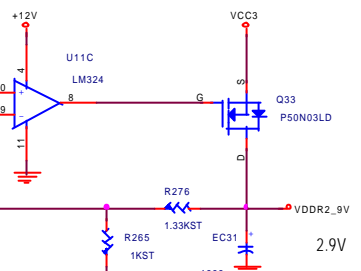
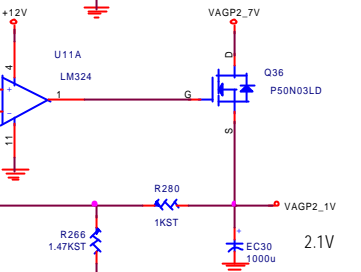
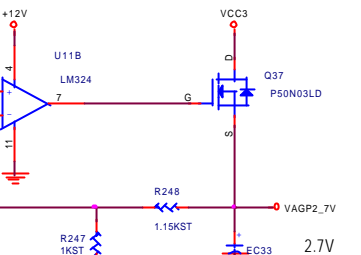
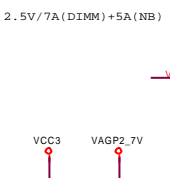

Micro Star Restricted Secret		Rev
Title <b>MS-5 ACPI Controller</b>		0A
Document Number <b>MS-6747</b>		
MICRO-STAR INT'L 880/R. 12th St. Jung-Ho City, Taipei Hsien, Taiwan http://www.msi.com.tw		Last Revision Date: Tuesday, March 04, 2003
Sheet 21 of 28		

# Voltage Regular Module

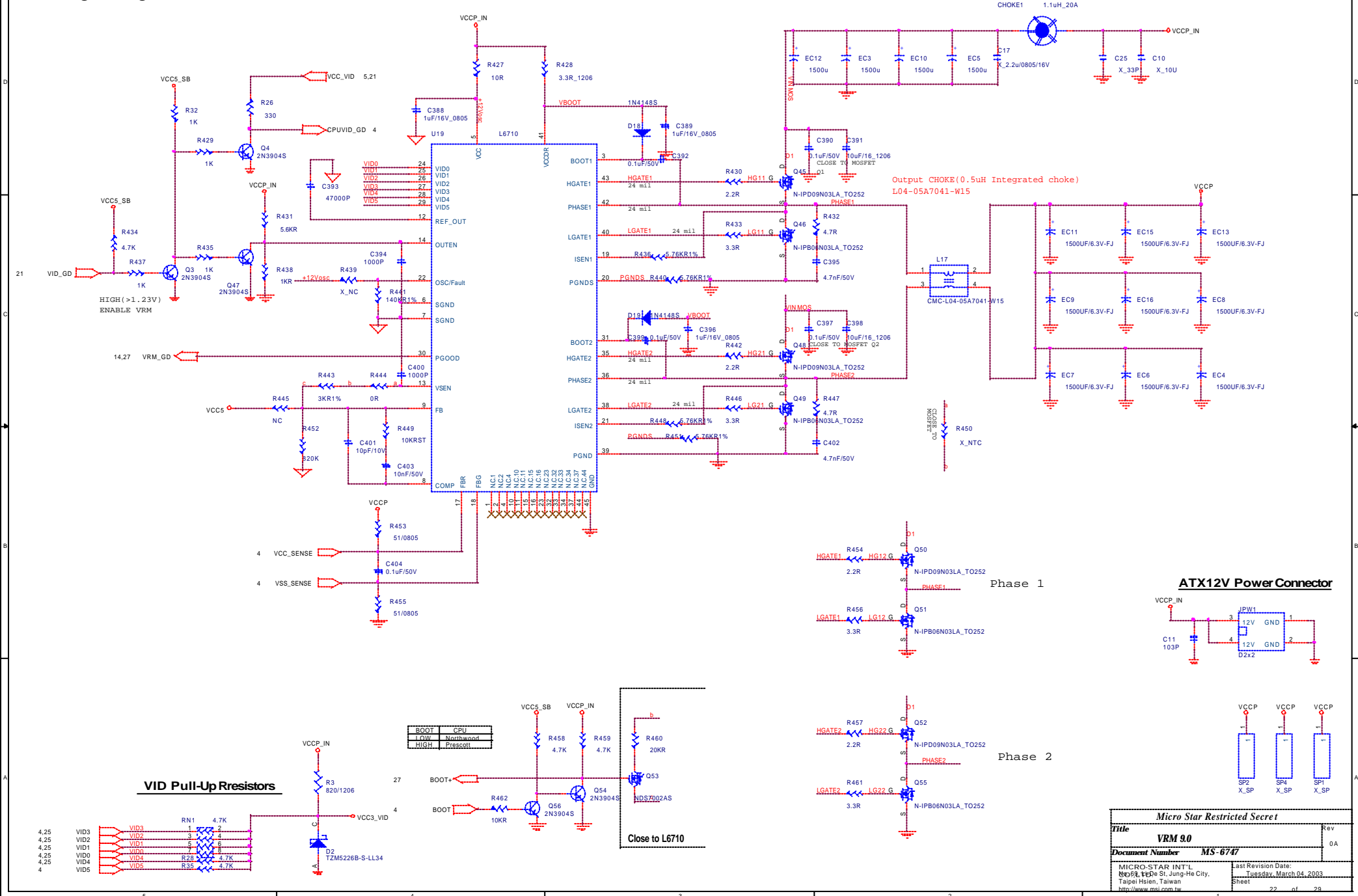

## VID Pull-Up Resistors

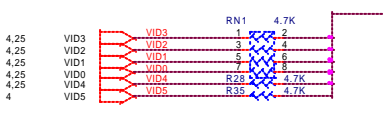

BOOT	CPU
LOW	Noribwood
HIGH	Prescott

Close to L6710

## ATX12V Power Connector

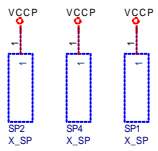
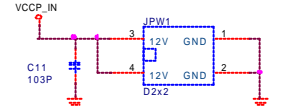

<b>Micro Star Restricted Secret</b>		Rev
<b>VRM 9.0</b>		0A
Document Number <b>MS-6747</b>		
MICRO-STAR INT'L 880/R. Rd. St. Jung-Ho City, Taipei Hsien, Taiwan <a href="http://www.msi.com.tw">http://www.msi.com.tw</a>		Last Revision Date: Tuesday, March 04, 2003 Sheet 22 of 28

# FRONT USB PORT

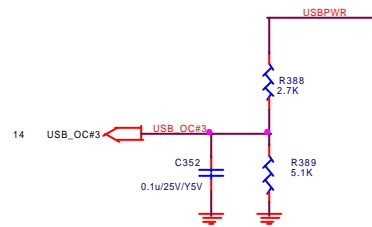
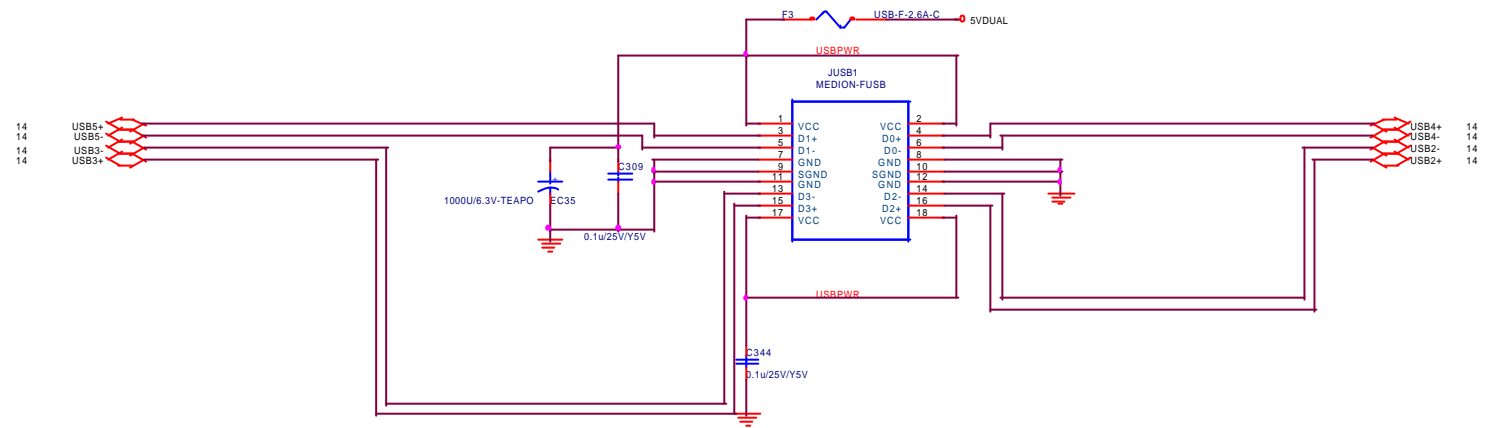

- \* USB Trace width : 7.5 mils
- \* USB Trace Spacing : 20 mils
- \* Differential USB Signals Trace, Spacing : 7.5 mils

<i>Micro Star Restricted Secret</i>	
<b>Title</b> Front USB Port	Rev 0A
<b>Document Number</b> MS-6728	
MICRO-STAR INT'L 80098, 100th St. Jung-Ho City, Taipei Hsien, Taiwan <a href="http://www.msi.com.tw">http://www.msi.com.tw</a>	Last Revision Date: Tuesday, March 04, 2003 Sheet 23 of 28

# REAR USB PORT

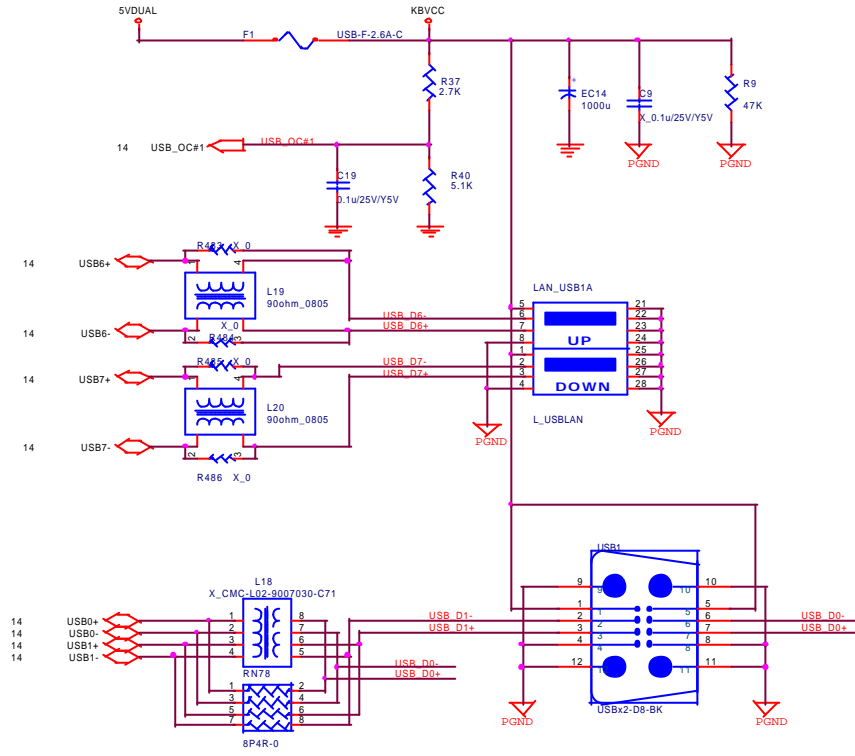

<b>Micro Star Restricted Secret</b>	
<b>Title</b>	Rev
<b>Rear USB Port</b>	0A
<b>Document Number</b>	<b>MS-6728</b>
MICRO-STAR INT'L 800/R. 100 St. Jung-Ho City, Taipei Hsien, Taiwan <a href="http://www.msi.com.tw">http://www.msi.com.tw</a>	Last Revision Date: Tuesday, March 04, 2003 Sheet 24 of 28



# Super I/O

## LPC SUPER IO W83627F/HF/THF

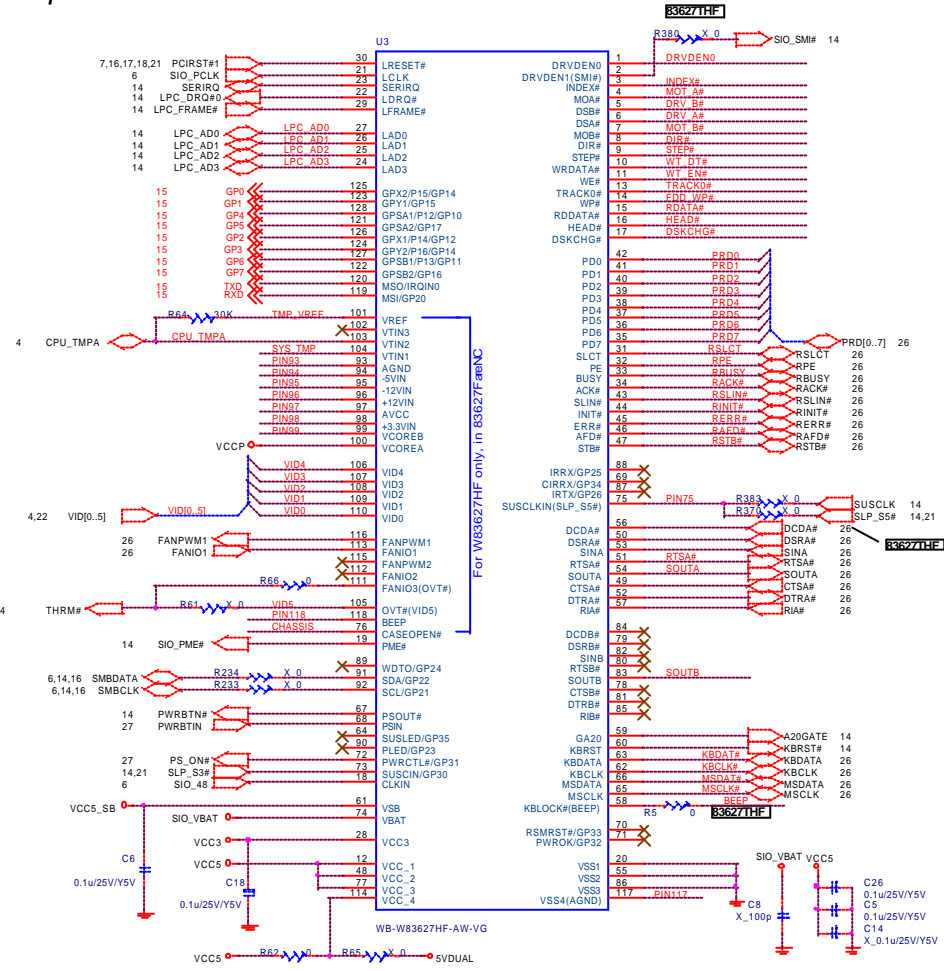

## FLOPPY CONNECTOR

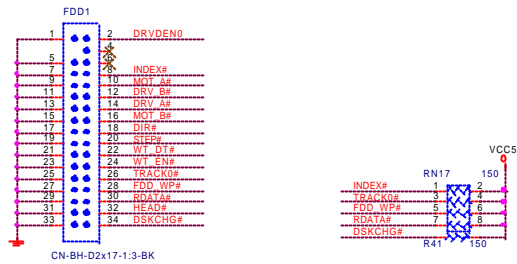

## FWH DECOUPLING CAPACITORS

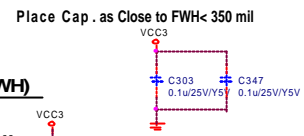

## For 627HF

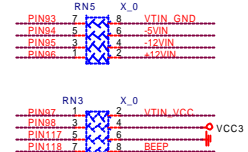

## For 627HF/HF

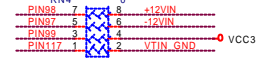

## BIOS PROTECT BLOCK

BIOS Update Config.		
HIGH	Un_protected	Default
LOW	Protected	Default

## Firmware Hub (FWH)

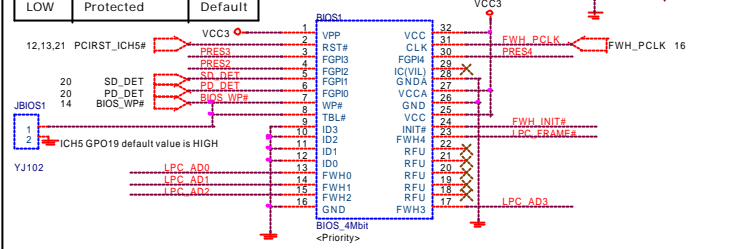

## FWH Resistors

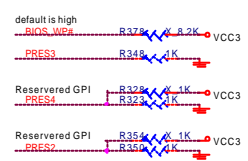

## INIT signal voltage translation

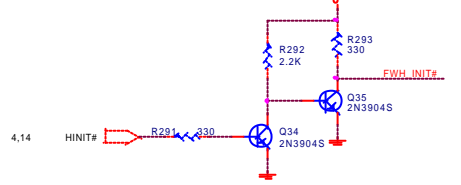

## LPC I/O STRAPPING RESISTOR

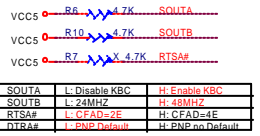

SOUTA	L: Disable KBC	H: Enable KBC
SOUTB	L: 24MHz	H: 48MHz
RTSA#	L: CFAD=2E	H: CFAD=4E
DTRA#	L: BNP Default	H: BNP no Default

## SPEAKER BLOCK

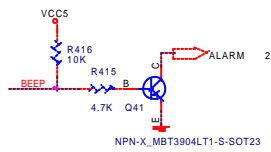

## Chassis Intrusion

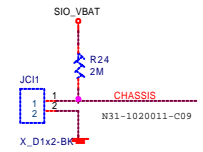

## Thermal Resistor

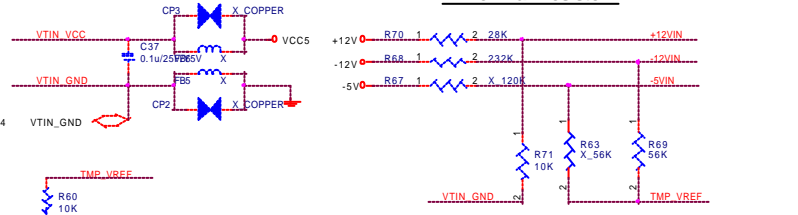

Micro Star Restricted Secret		
Title	Rev	
W 627HF LPC I/O / FWH	0A	
Document Number	MS-6728	
MICRO-STAR INT'L	Last Revision Date:	
880-RF, #9 St. Jung-Ho City,	Tuesday, March 04, 2003	
Taipei Hsien, Taiwan	Sheet	
http://www.msi.com.tw	25 of 28	

NOTE: LOCATE CLOSE STATUS PANEL

# KB/MS/LPT/COM Port/FAN

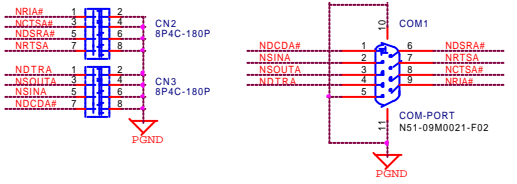
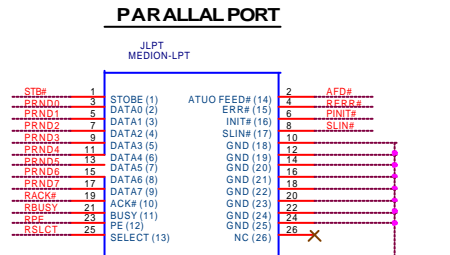
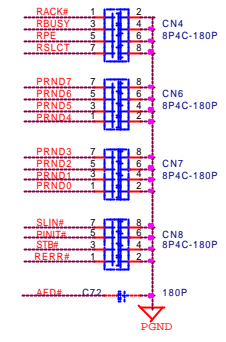
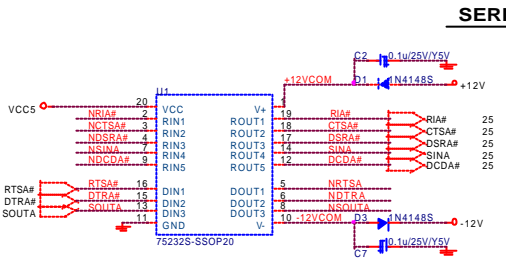
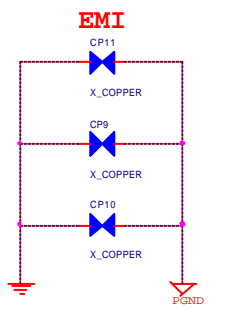
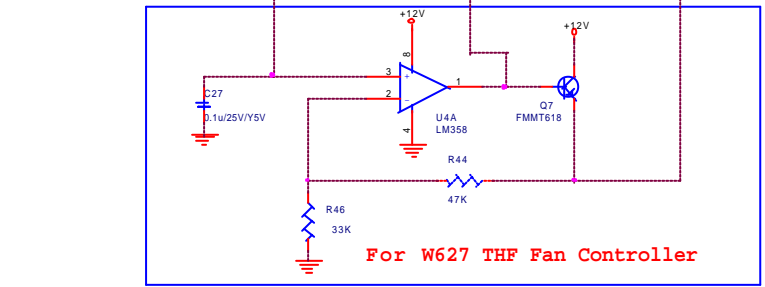
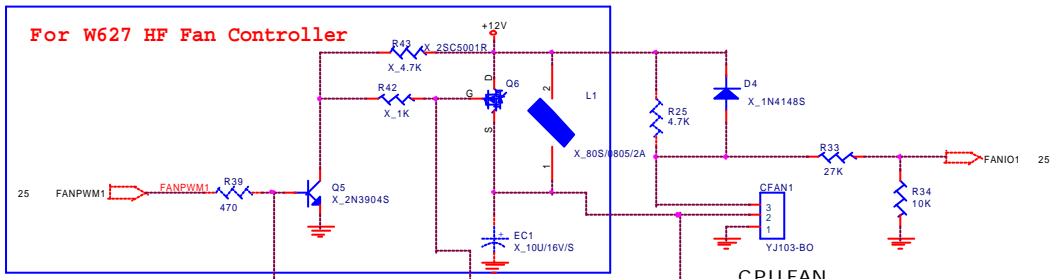
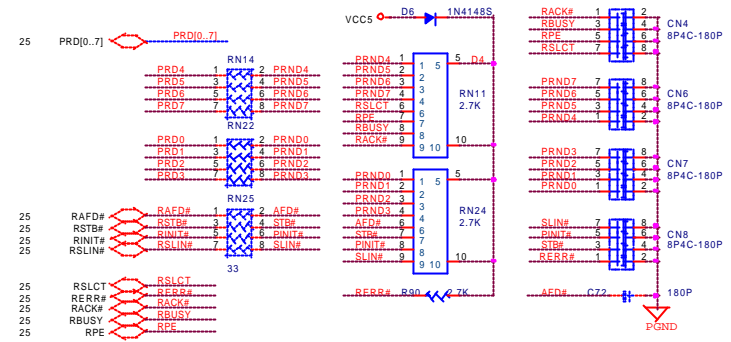
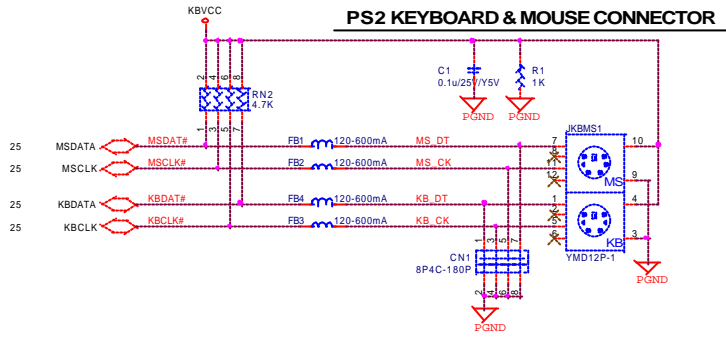

<b>Micro Star Restricted Secret</b>		
<b>Title</b>	<b>Rev</b>	
<b>KB/MS/LPT/COM Port/FAN</b>	0A	
<b>Document Number</b>	<b>MS-6728</b>	
MICRO-STAR INT'L 800 R. Rd. St. Jung-Ho City, Taipei Hsien, Taiwan http://www.msi.com.tw	1st Revision Date: Tuesday, March 04, 2003 Sheet 26 of 28	



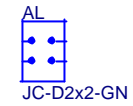
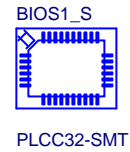
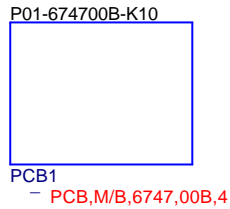
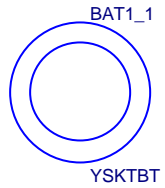

**JAUDIO1 (1-2) , (3-4)**

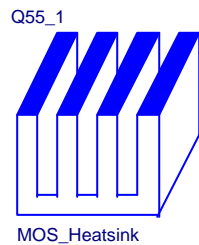
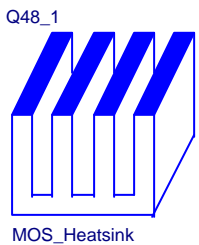
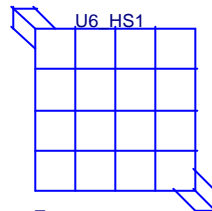
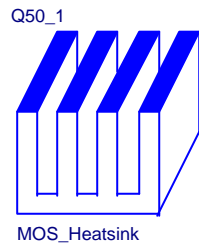
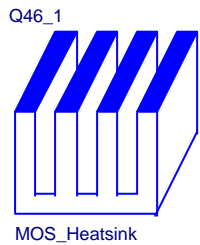
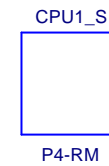
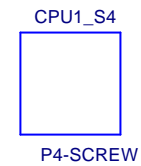
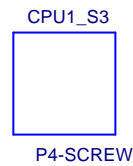
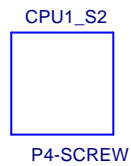
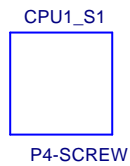
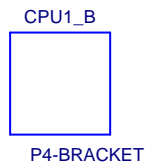

<b>Micro Star Restricted Secret</b>	
<b>Title</b> <b>Manual Part</b>	Rev 0B
<b>Document Number</b> <b>MS-6747</b>	
MICRO-STAR INT'L No. 697-D, De St, Jung-He City, Taipei Hsien, Taiwan <a href="http://www.msi.com.tw">http://www.msi.com.tw</a>	Last Revision Date: Tuesday, March 04, 2003
	Sheet 28 of 29