

1.2 System Board Layout

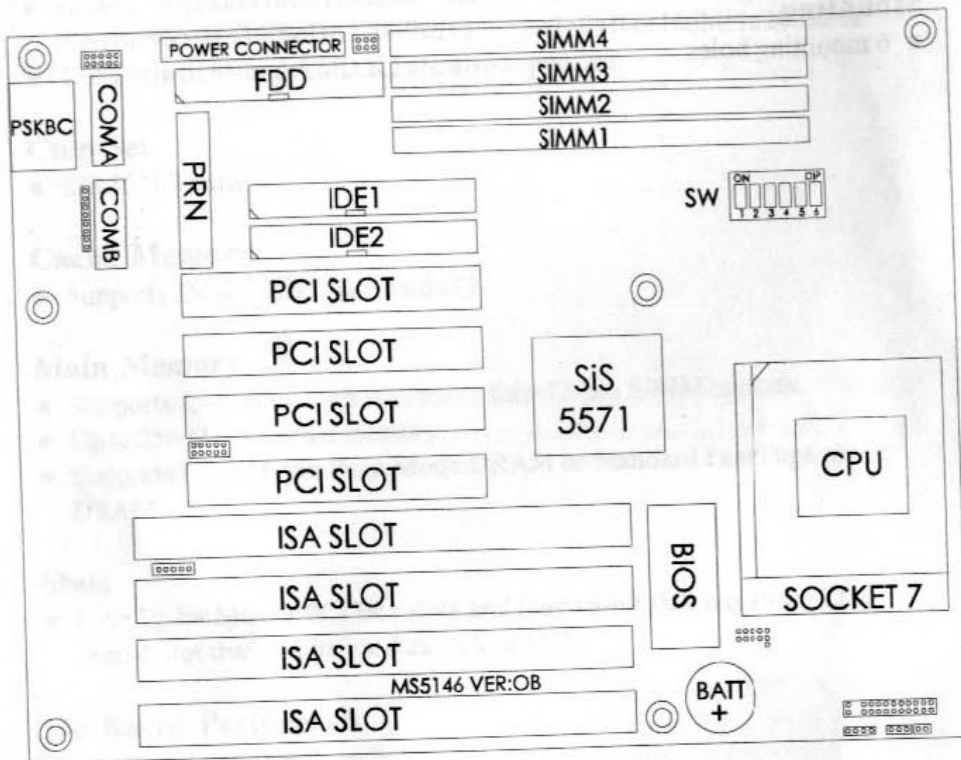

MS-5146

Chapter 2

Hardware Installation

2.1 Central Processing Unit: CPU

The MS-5146 motherboard operates with Intel® P54C/P55C, Cyrix® 6x86 and AMD® 5K86 processors. It could operate with 2.5V to 3.52V processors. The motherboard provides a 321-pin ZIF Socket 7 for easy CPU installation, a DIP switch (SW1) to set the proper speed for the CPU and a Jumper block (JV2 - JV4) for setting the CPU voltage. The CPU should always have a cooling fan attached to prevent overheating.

2.1-1 CPU Installation Procedure

1. Pull the lever sideways away from the socket then raise the lever up to a 90-degree angle.

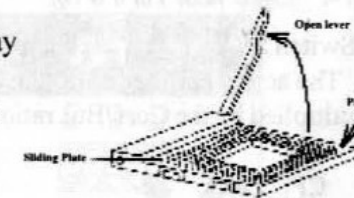

2. Locate Pin 1 in the socket and look for the white dot or cut edge in the CPU, match Pin 1 with the white dot/cut edge then insert the CPU. It should insert easily.

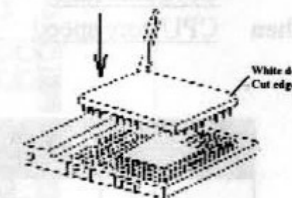

3. Press the lever down to complete the installation.

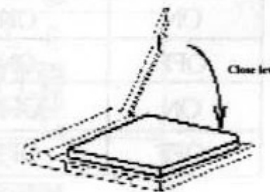

2.1-1 CPU Core Speed Derivation Procedure

1. The 4 CPU clock frequencies that the system supports are 50 MHz, 55MHz, 60MHz and 66.6MHz (To adjust SW1 pin 3 and 4). See the following chart to set the different Host Clock Frequencies.

| SW1 | | | | CPU | PCI |
|-----|-----|-----|--------|---------|---------|
| 3 | 4 | 5 | 6 | CLOCK | CLOCK |
| ON | ON | OFF | ON/OFF | 50MHz | 25MHz |
| OFF | ON | OFF | ON/OFF | 55MHz | 27.5MHz |
| ON | OFF | OFF | ON/OFF | 60MHz | 30MHz |
| OFF | OFF | OFF | ON/OFF | 66.6MHz | 33MHz |
| ON | OFF | ON | ON/OFF | 75MHz | 33MHz |
| OFF | OFF | ON | ON/OFF | 75MHz | 37.5MHz |

Note: SW1 Pin 6 is for setting Linear or Toggle mode. Linear mode Pin 6 is On. Toggle mode Pin 6 is Off.

2. The DIP Switch SW1 (1,2) is used to set the Core/Bus (Fraction) ratio of the CPU. The actual core speed of the CPU is the Host Clock Frequency multiplied by the Core/Bus ratio. For example:

If $\frac{\text{CPU Clock}}{\text{Core/Bus ratio}} = 66\text{MHz}$
 then $\text{CPU core speed} = \frac{\text{Host Clock} \times \text{Core/Bus ratio}}{66.6\text{MHz} \times 3/2} = 100\text{MHz}$

| SW1 | | CPU |
|-----|-----|----------------|
| 1 | 2 | CORE/BUS RATIO |
| ON | ON | 5/2 |
| OFF | ON | 3/1 |
| ON | OFF | 2/1 |
| OFF | OFF | 3/2 |

3. The PCI Bus Clock is the CPU Clock Frequency divided by 2.

2.1-2 CPU Voltage Setting: JV2 - JV4

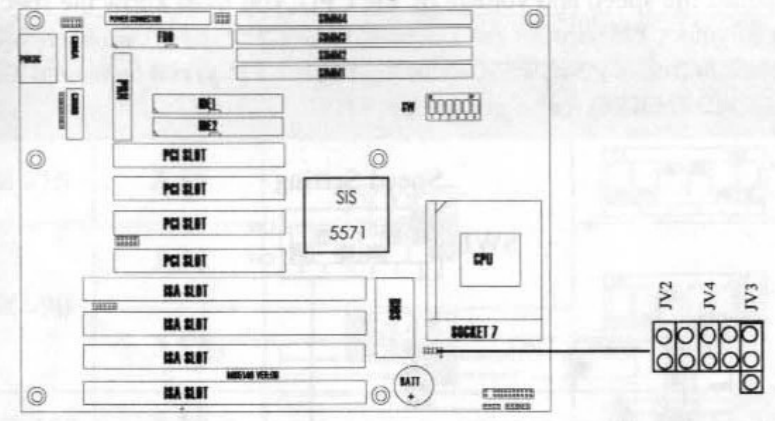

| V I/O | Vcore | JV1 | | | | | | | | | | | | | | | | |
|-------|-------|---|--|--|--|--|--|--|--|--|--|--|--|--|--|--|--|--|
| 3.38 | 3.38 | <table border="1"> <tr><td></td><td></td><td></td><td></td></tr> <tr><td></td><td></td><td></td><td></td></tr> <tr><td></td><td></td><td></td><td></td></tr> <tr><td></td><td></td><td></td><td></td></tr> </table> | | | | | | | | | | | | | | | | |
| | | | | | | | | | | | | | | | | | | |
| | | | | | | | | | | | | | | | | | | |
| | | | | | | | | | | | | | | | | | | |
| | | | | | | | | | | | | | | | | | | |
| 3.52 | 3.52 | <table border="1"> <tr><td></td><td></td><td></td><td></td></tr> <tr><td></td><td></td><td></td><td></td></tr> <tr><td></td><td></td><td></td><td></td></tr> <tr><td></td><td></td><td></td><td></td></tr> </table> | | | | | | | | | | | | | | | | |
| | | | | | | | | | | | | | | | | | | |
| | | | | | | | | | | | | | | | | | | |
| | | | | | | | | | | | | | | | | | | |
| | | | | | | | | | | | | | | | | | | |
| 3.3 | 2.5 | <table border="1"> <tr><td></td><td></td><td></td><td></td></tr> <tr><td></td><td></td><td></td><td></td></tr> <tr><td></td><td></td><td></td><td></td></tr> <tr><td></td><td></td><td></td><td></td></tr> </table> | | | | | | | | | | | | | | | | |
| | | | | | | | | | | | | | | | | | | |
| | | | | | | | | | | | | | | | | | | |
| | | | | | | | | | | | | | | | | | | |
| | | | | | | | | | | | | | | | | | | |
| 3.3 | 2.8 | <table border="1"> <tr><td></td><td></td><td></td><td></td></tr> <tr><td></td><td></td><td></td><td></td></tr> <tr><td></td><td></td><td></td><td></td></tr> <tr><td></td><td></td><td></td><td></td></tr> </table> | | | | | | | | | | | | | | | | |
| | | | | | | | | | | | | | | | | | | |
| | | | | | | | | | | | | | | | | | | |
| | | | | | | | | | | | | | | | | | | |
| | | | | | | | | | | | | | | | | | | |
| 3.3 | 2.9 | <table border="1"> <tr><td></td><td></td><td></td><td></td></tr> <tr><td></td><td></td><td></td><td></td></tr> <tr><td></td><td></td><td></td><td></td></tr> <tr><td></td><td></td><td></td><td></td></tr> </table> | | | | | | | | | | | | | | | | |
| | | | | | | | | | | | | | | | | | | |
| | | | | | | | | | | | | | | | | | | |
| | | | | | | | | | | | | | | | | | | |
| | | | | | | | | | | | | | | | | | | |

2.1-3 CPU Speed and Voltage Setting: SW1 & JV2-JV4

To adjust the speed and voltage of the CPU, you must know the specification of your CPU (*always ask the vendor for CPU specification*) then look at Table 2.1 (Intel® P54C/P55C-MMX), Table 2.2 (Cyrix® 6x86) and Table 2.3 (AMD® 5K86) for proper setting.

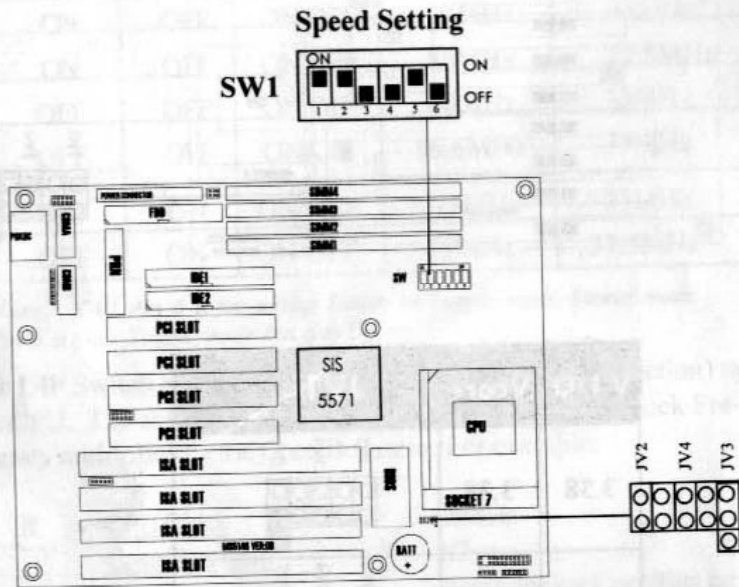

Table 2.1 Intel® P54C(PENTIUM), P55C(MMX) CPU

| CPU Type | CPU Voltage | | JV2~JV4 | CPU Speed SW1 |
|----------|-------------|-------|---------|------------------|
| | V1/O | Vcore | | |
| P54C-75 | 3.38 | | | |
| P54C-90 | 3.38 | | | |
| | 3.52 | | | |
| P54C-100 | 3.38 | | | |
| P54C-120 | 3.38 | | | |
| P54C-133 | 3.52 | | | |
| P54C-150 | 3.52 | | | |
| P54C-166 | 3.52 | | | |
| P55C-166 | 3.33 | 2.8 | | |
| P54C-200 | 3.52 | | | |
| P55C-200 | 3.33 | 2.8 | | |

CHAPTER 2 HARDWARE INSTALLATION

Table 2.2 Cyrix® 6x86 CPU

Cyrix® 6x86 CPU uses P to rate the speed of there processor base on Intel® CPU core speed , for example P120+ (100MHz) has 120MHz core speed of Intel® but has 100MHz core speed in Cyrix®. Cyrix® 6x86 CPU should always uses a more powerful fan (ask vendor for proper cooling fan).

| CPU Type | CPU Voltage | | | CPU Speed |
|-------------------|-------------|-------|---------|-----------|
| | V/I/O | Vcore | JV2~JV4 | SW1 |
| P120+ (100MHz) | 3.52 | | | |
| P133+ (110MHz) | | | | |
| P150+ (120MHz) | | | | |
| P166+ (133MHz) | | | | |
| P200+ (150MHz) | 3.4 | 2.8 | | |
| P200+ (150MHz) | 3.52 | | | |

Note: The Cyrix CPU can be set to Linear or Toggle mode, But we recom mend that you use the linear mode so the Pin 6 is On.
 -P200+(150MHz)-A PCI clk 33MHz. (Default) --Asyn
 -P200+(150MHz)-S PCI clk 37.5MHz. -- Syn

CHAPTER 2 HARDWARE INSTALLATION

Table 2.3 AMD® 5K86 CPU

AMD® 5K86 CPU uses PR to rate the speed of there processor base on Intel® CPU core speed , for example PR133+ (100MHz) has 133MHz core speed of Intel® but has 100MHz core speed in AMD® 5K86 CPU.

| CPU Type | CPU Voltage | | | CPU Speed |
|--------------------|-------------|-------|---------|-----------|
| | V/I/O | Vcore | JV2~JV4 | SW1 |
| PR75+ | 3.52 | | | |
| PR90+ (90MHz) | | | | |
| PR100+ (100MHz) | | | | |
| PR133+ (100MHz) | | | | |

2.3 Case Connector (JFP)

The Turbo LED, Turbo Switch, Hardware Reset, Key Lock, Power LED, Power Saving LED, Sleep Switch, Speaker and HDD LED all connected to the JFP connector block.

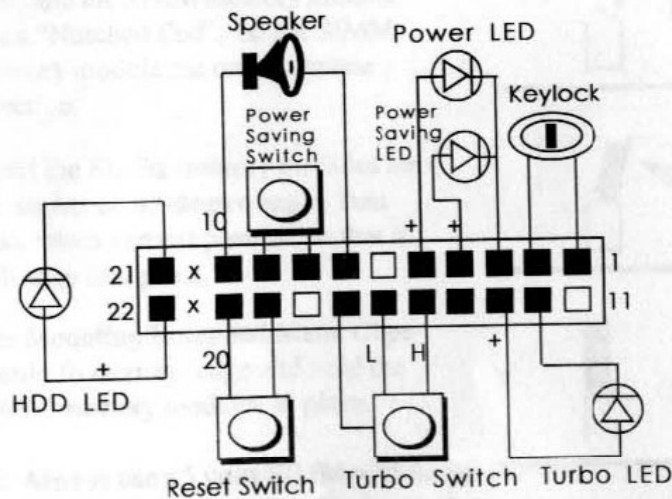
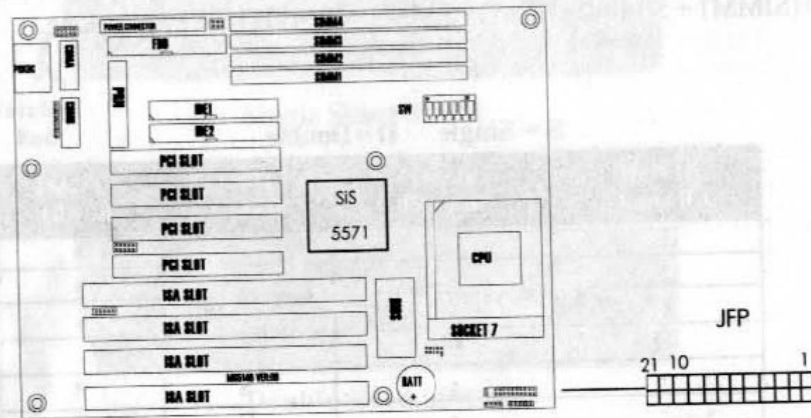

Figure 2.1

2.3-1 Turbo LED

The Turbo LED are use to monitor if the turbo switch is ON/OFF. You can connect the Turbo LED from the system case to this pin. (see Figure 2.1)

2.3-2 Hardware Reset

Reset switch are use to reboot the system rather than turning the power ON/OFF, but avoid rebooting will the HDD LED is lit. You can connect the Reset switch form the system case to this pin. (see Figure 2.1)

2.3-3 Keylock

Keylock allows you to disabled the keyboard for security purposes. You can connect the keylock to this pin. (see Figure 2.1)

2.3-4 Power LED

The Power LED is always lit while the system power is on. You can connect the Power LED form the system case to this pin. (see Figure 2.1)

2.3-5 Suspend Switch

The Turbo switch or Suspend switch allows the user to suspend the system will not in use. It can be controlled by BIOS power management setup switch function. You can connect the Turbo Switch from the system case to this pin. (see Figure 2.1)

2.3-6 Speaker

Speaker from the system case are connected to this pin. (see Figure 2.1)

2.3-7 HDD LED

HDD LED shows the activity of a hard disk drive. avoid tuning the power off while the HDD led is lit. You can connect the HDD LED from the system case to this pin. (see Figure 2.1).

2.9 Keyboard Connector: PSKBC

The system board provides a standard PS/2 style keyboard DIN connector for attaching a keyboard. You can plug a keyboard cable directly to this connector.

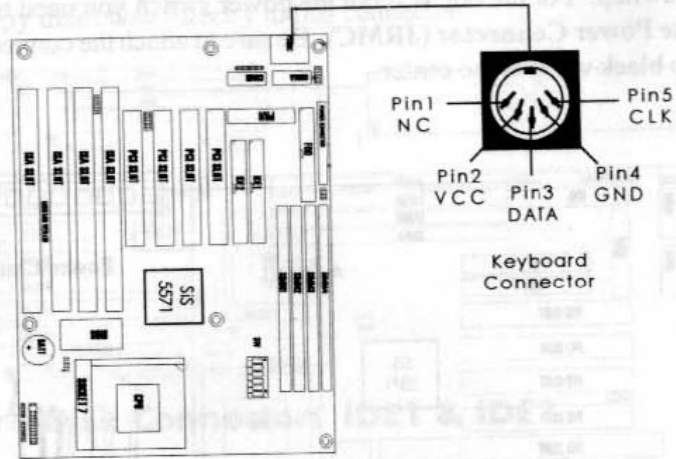

2.10 Mouse Connector: JMS

The system board provides a 5-pin connector for PS/2 mouse cable (optional). You can plug a PS/2 style mouse to PS/2 mouse cable. The connector location and pin definition as shown below.

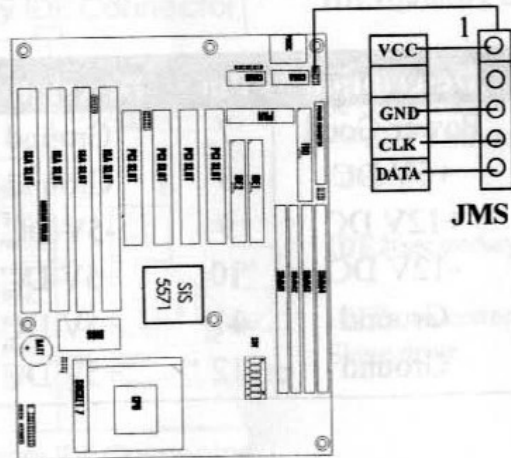

2.11 IrDA Infrared Module Connector: IR

The system board provides a 5-pin infrared connector (IR) for IR module. This connector is for optional wireless transmitting and receiving infrared module. You must configure the setting through BIOS setup.

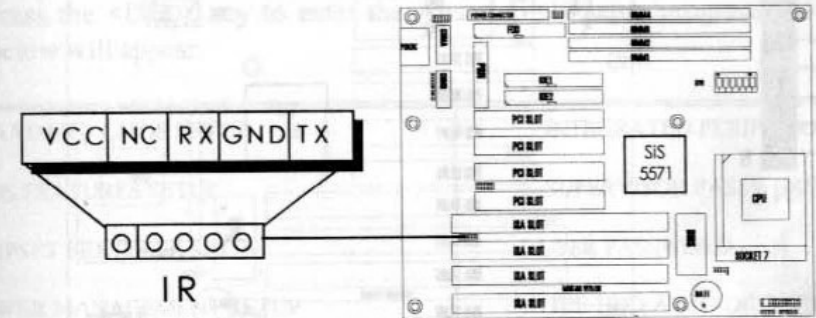

2.12 USB Connector: USB (Reserved)

This 10-pin connector supports USB devices. This function is a reserved function.

