

# Chapter 2









## Hardware Installation

This chapter provides information on hardware installation and configuration.

### Clock Selection: SW1

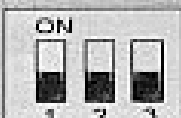
Set switch SW1 according to the following values: Intel® P54C & P55C(MMX) 75MHz~200MHz, or Cyrix® P120+~P166+ Refer to the following table for configuration options. (The following table is setting for Intel® and AMD® or Cyrix®)



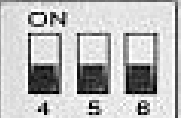

## SW1 setting for Intel® CPU

<i>CPU Internal Clock</i>	<i>SW1 1 2 3</i>	<i>Ratio (ext/int)</i>	<i>SW1 4 5 6</i>	<i>External Clock</i>
75 MHz		1.5		50MHz
90 MHz		1.5		60MHz
100 MHz		1.5		66MHz
120 MHz		2		60MHz
133 MHz		2		66MHz

CPU Internal Clock	SW1 1 2 3	Ratio (ext/int)	SW1 4 5 6	External Clock
150 MHz		2.5		60MHz
166 Mhz P54C/P55C		2.5		66MHz
200 MHz P54C		3		66MHz
200 MHz P55C		3		66MHz

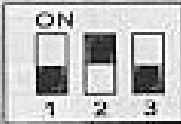
233  
P55C

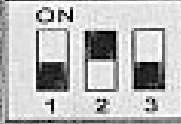
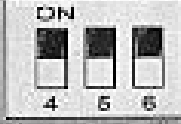
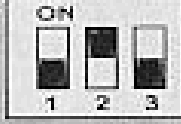
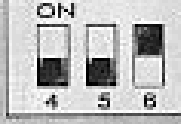
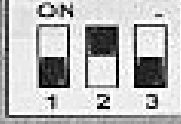

## SW1 setting for Cyrix® CPU

<i>CPU P-Rating</i>	<i>SW1 1 2 3</i>	<i>Ratio (ext/int)</i>	<i>SW1 4 5 6</i>	<i>External Clock</i>
P120+		2		50MHz
P133+		2		55MHz
P150+		2		60MHz
P166+		2		66MHz

*Note!*  

The AMD® 75~100MHz CPU Voltage must set to 3.52V.

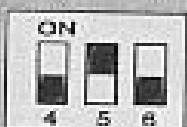
## SW1 setting for AMD® CPU

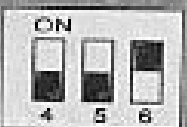
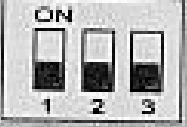
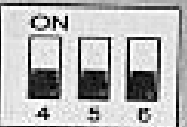
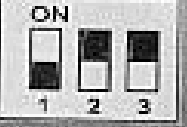
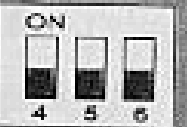
CPU Internal Clock	SW1 1 2 3	Ratio (ext/int)	SW1 4 5 6	External Clock
75 MHz		1.5		50MHz
90 MHz or PR120		1.5		60MHz
100 MHz or PR133		1.5		66MHz
PR166		1.75		66MHz

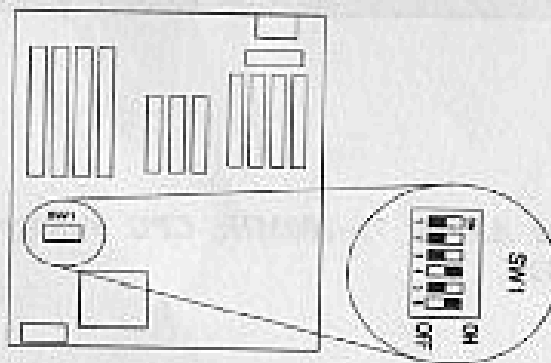

Figure 2-1 : SW1 Settings.

## CPU Voltage Selector: JV2~ JV6

For jumpers, JV2 – JV6 select either a 3.38~3.52V or 2.8 volt power source for the P54C(3.52V for Intel® special CPU) . P55C(MMX) or CYRIX® 6X86L V(I/O) is 3.4~3.6V and V(core) range 2.8 Volt. These setting supports dual (2.8V) or signal (3.38V & 3.52V) voltage CPU. Refer to the following table for configuration options.

CPU Voltage	3.38V	3.52V	2.8V
JV2~JV6			

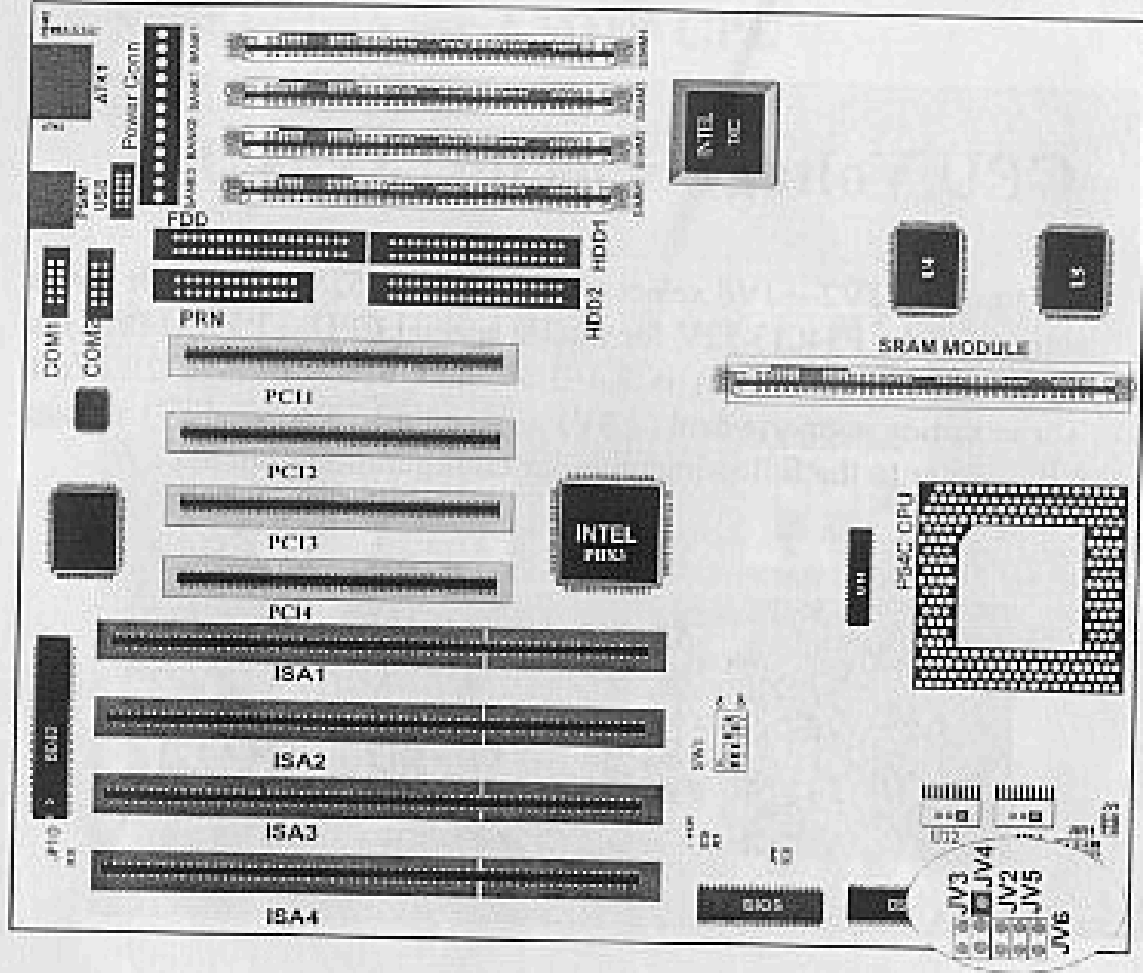

Figure 2-2 : CPU Voltage Selector JV2~ JV6.

## Cache Configuration

The system board supports flexible L2 cache configuration, cache size of 256KB (two 32Kx32) or 512KB (two 64Kx32) Pipeline Burst SRAM can be used on board. An optional cache module can be used also to increase the motherboard's configuration flexibility, it can be use with on board cache or by itself to provide total upgrade flexibility. The cache is sized by the BIOS. The Cache module installed on TR4 needs to be pin-compatible secondary cache module family that adheres to Intel COAST1.3 Specification. (or later).

*Note!*

*This section is only optional when cache slots is available on TR4 mother board. You need to use Coast Module version 1.3 or later. The system may work inconsistently when the incorrect module is used on TR4 mother board.*

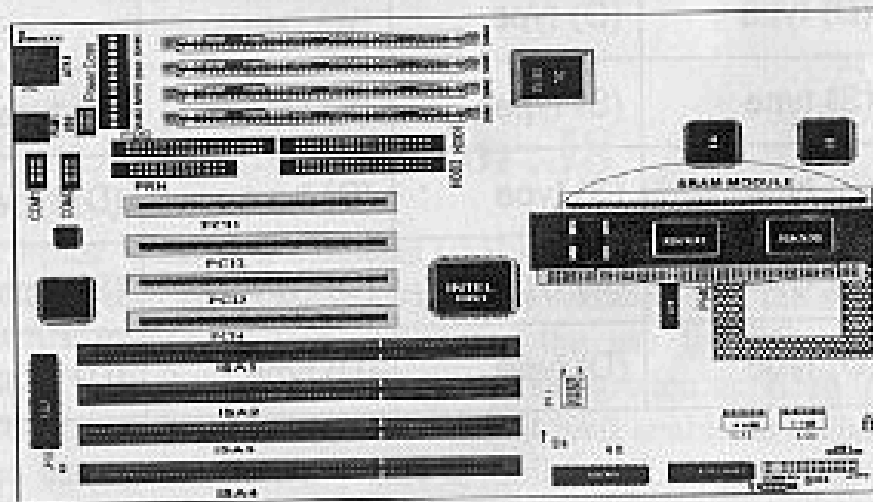

**Figure 2-3: Install Cache Module.**



## Memory Bank Configuration

The system board supports four memory banks and provides four PIN, single in-line on-board memory module (SIMM) sockets, numbered SIMM1 — SIMM4.

Each socket accepts single density or double density (D)SIMM in the following sizes: 4M(S), 8M(D), 8M(S), 16M(S), 32M(D), and 64M(S)The maximum memory configuration is 256M bytes

See table below for allowable SIMM type configurations.

SIMM1	SIMM2	SIMM3	SIMM4
(S) type	(S) type	—	—
(D) type	(D) type	—	—
(S) type	(S) type	(S) type	(S) type
(S) type	(S) type	(D) type	(D) type
(D) type	(D) type	(S) type	(S) type
(D) type	(D) type	(D) type	(D) type



*You must install two of the same type of EDO or FP in the SIMM sockets SIMM1/SIMM2 or SIMM3/SIMM4 when you mix the EDO and fast page DRAM. For example:*

<u>SIMM1</u>	<u>SIMM2</u>	<u>SIMM3</u>	<u>SIMM4</u>
EDO	EDO	FP	FP
FP	FP	EDO	EDO

*The chip maximum DRAM configuration can be set to 512MB.but driving current only can support 72 pcs of DRAM chip. so we suggest not to exceed 72 pcs of DRAM chip for total system memory .*

## SIR Connector: JIR1

If you want to use infrared function. this connect connector with the module of the IR modulator Please refer to *Figure 2-4*.

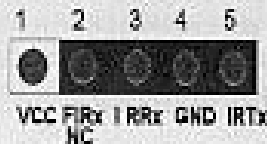

## USB Connector: J8

This 10-pins connector connects USB cable to support USB device. the system board provide two serial bus interface ports. the advantage with USB implementation is to ease the use for PC peripheral expansion with the focus on Computer integration applications. And with the transfer rate of up to 12 Mb/s. it will enable new classes of devices that which were not able to well in PC. if you want to use USB function. Please refer to *Figure 2-4*. Check the pin definition and polarity of your cable before you connect it

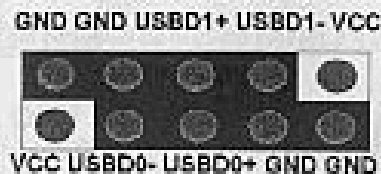

## Keyboard Connector ATK

The system board provides a standard five pin female DIN connector, ATK, for attaching a keyboard. You can plug a keyboard cable directly into this connector. See *Figure 2-4* for connector locations.

## PS/2 keyboard connector: PSK

PSK is a standard six-pin female mini-DIN Connector. You can plug a PS/2 keyboard cable directly into this connector.

## PS/2 mouse connector: PSM1, PSM2

You can attach a PS/2 mouse with a six-pin mini-DIN connector



directly to the system board with this connector - PS2/M2. Alternatively, PS2/M is a five-pin male PIN connector. It connects with an extended Mouse cable for PIN to mini-DIN connections.

*Note!*

If a PS/2 mouse is used, the BIOS PS/2 mouse function should be enable, the system board will be assign IRQ12 to the PS/2 mouse. Otherwise, the Interrupt Request IRQ12 will be available for other adapters.

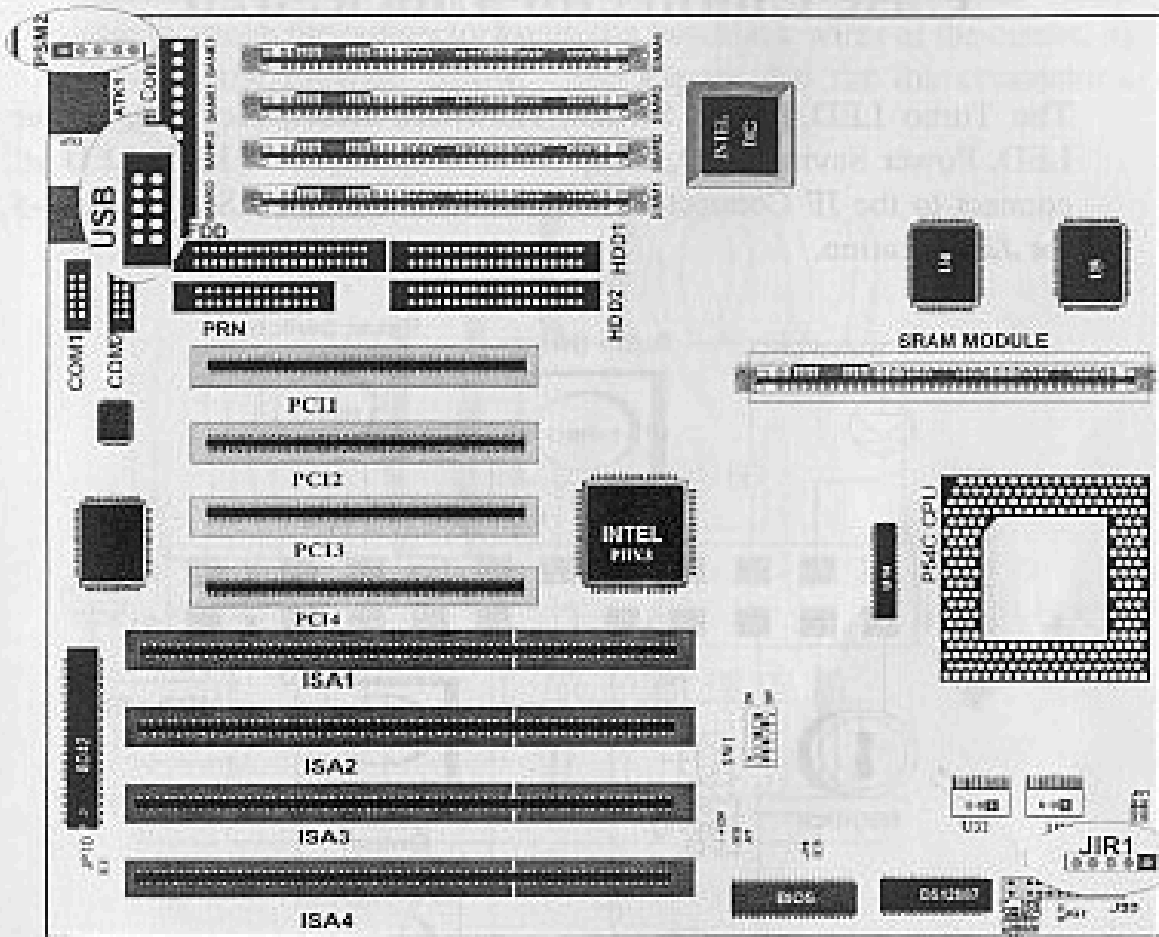

Figure 2-4: USB ,JIR & PSM2 Connector.

## Case Connector Block: J20

The Turbo LED, Turbo Switch, Hardware Reset, Keylock, Power LED, Power Saving LED, Sleep Switch, Speaker and HDD LED all connect to the JF Connector Block as shown below. See *figure 2-5* for *J20* location.

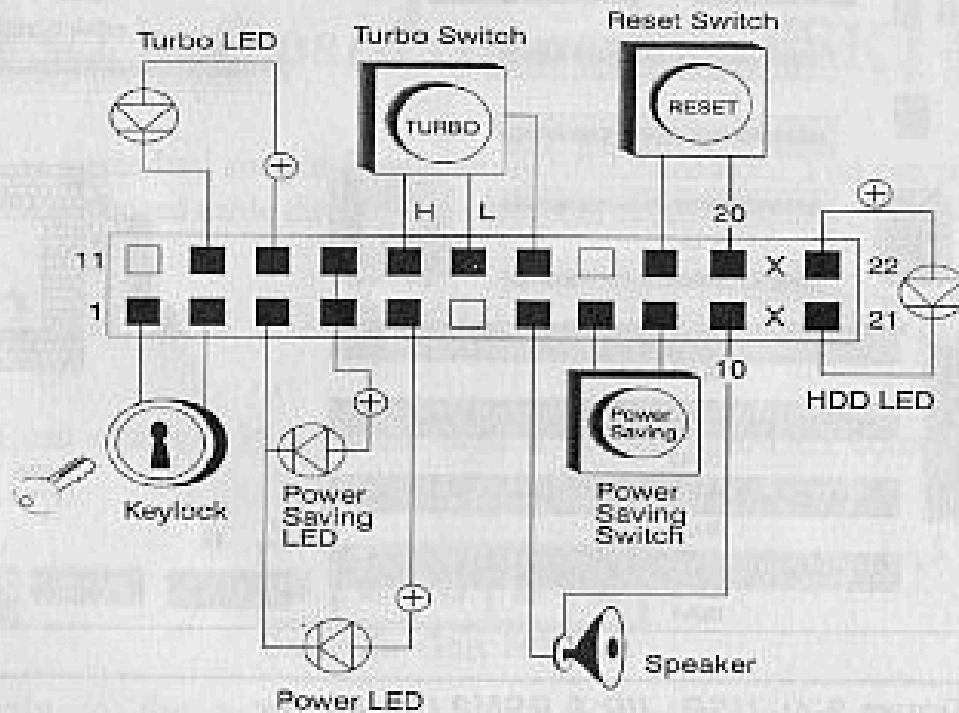
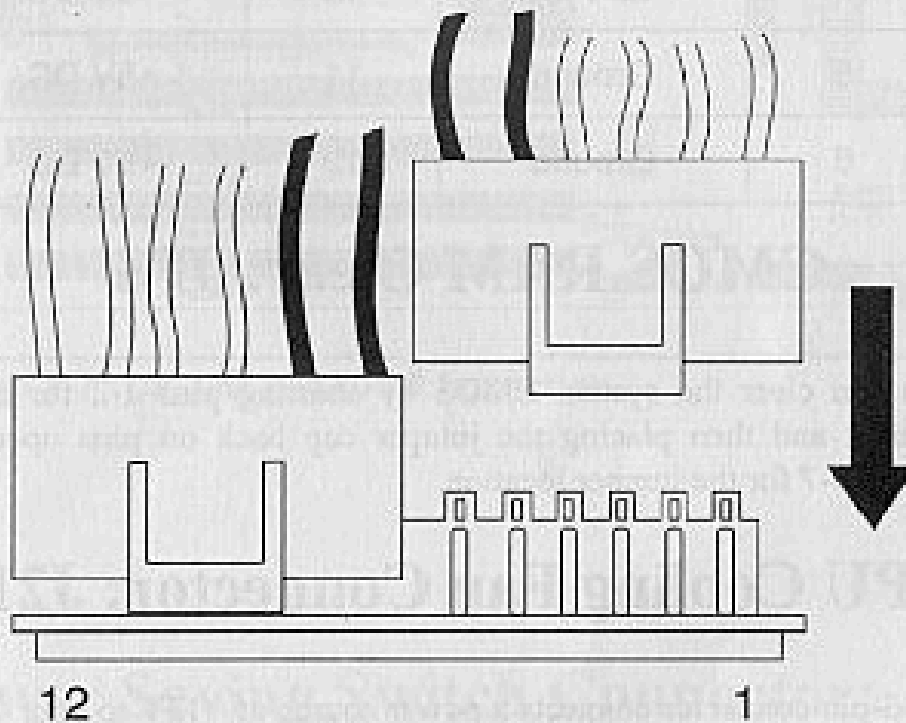

Figure 2-5: Case Connector Block - J20.

## Power Supply Connector: J 1

The power supply connector is a twelve-pin male connector. Dual connectors from the power supply can fit in only one direction. Make sure to attach the connectors with the two black wires at the center, as show in the diagram below. See *Figure 2-6* for the connector's location.



**Figure 2-6: Attaching Power Supply Connectors.**