

Chapter 1

INTRODUCTION

The MS-6182 ATX WH8 mainboard is a high-performance computer mainboard based on Intel® 810 chipset. The MS-6182 is designed for the Intel® Pentium® II/III or Celeron™ processor for inexpensive business/personal desktop markets.

The Intel® 810 chipset is the first generation Integrated Graphics chipset for the Intel® Pentium® II/III Celeron™ processor. The graphics accelerator architecture consists of dedicated multi-media engines executing in parallel to deliver high performance 3D, 2D, and motion compensation video capabilities. An integrated centralized memory arbiter allocates memory bandwidth to multiple system agents to optimize system memory utilization. A new chipset component interconnect, the hub interface, is designed into the Intel® 810 chipset to provide an efficient communication channel between the memory controller hub and I/O hub controller.

The Intel® 810 chipset contains three core components: the Graphics and Memory Controller Hub (GMCH), the I/O Controller Hub (ICHO/ICH) and the Firmware Hub (FWH). The GMCH integrates a 66/100MHz, P6 family system bus controller, 2D/3D graphics accelerator, 100MHz SDRAM controller and high-speed hub interface for communication with the ICHO/ICH. The ICHO/ICH integrates an Ultra ATA/33(ICHO) or Ultra ATA/66(ICH) controller, USB host controller, LPC interface controller, FWH interface controller, PCI interface controller, AC'97 digital controller and a hub interface for communication with the GMCH.

The Intel® 82802 Firmware Hub (FWH) component is part of the Intel® 810 chipset. The FWH is key to enabling future security and manageability infrastructure for the PC platform.

1.1 Mainboard Features

CPU

- Slot 1 for Intel® Pentium® II/Pentium® III/Celeron™ processor.
- Supports 233MHz, 266MHz, 300MHz, 333MHz, 350MHz, 400MHz, 450MHz, 500MHz and faster processor.

Chipset

- Intel® 810 (GMCH) chipset. (421 BGA)
 - Integrated Graphics Controller
 - Intel DDM Architecture
 - SDRAM memory Independent of System Bus
- Intel® ICH/ICH0 chipset. (241 BGA)
 - AC'97 Controller Integrated
 - 2 full IDE channels, up to ATA66
 - 2 full IDE channels, up to ATA33 (ICH0 only)
 - Low pin count interface for SIO

Front Side Bus (FSB)

- 66/100MHz clocks are supported.

Main Memory

- Support three 168-pin DIMM sockets.
- Support a maximum memory size of 256MB(64-bit) or 512MB(128-bit) SDRAM.

Slots

- One AMR(Audio Modem Riser) and one PTI(PanelLink TV-Out Interface)
- Six 32-bit PCI Bus slots and one 16-bit ISA slot (wherein one PCI/ISA slot is shared).
- Support 3.3v/5v PCI bus Interface.

On-Board IDE

- An IDE controller on the ICH chipset provides IDE HDD/CD-ROM with PIO, Bus Master and Ultra DMA/66 operation modes.
- Can connect up to four IDE devices.

On-Board Peripherals

- On-Board Peripherals include:
 - 1 floppy port supports 2 FDD with 360K, 720K, 1.2M, 1.44M and 2.88Mbytes.
 - 2 serial port (COMA + COMB)
 - 1 parallel port supports SPP/EPP/ECP mode
 - 2 USB ports and 2 USB connectors
 - 1 IrDA connector for SIR.
 - 1 VGA port

Video

- GMCH chip integrated
- 2D/3D Graphics
- Onboard 4MB Display Cache (optional)

Audio

- ICH/ICH0 chip integrated
- Creative® ES1373 (optional)
 - Running on PCI BUS.
 - Support Direct Sound and Direct Sound 3D
 - AC97' Compliant

BIOS

- The mainboard BIOS provides “Plug & Play” BIOS which detects the peripheral devices and expansion cards of the board automatically.
- The mainboard provides a Desktop Management Interface(DMI) function which records your mainboard specifications.
- Adjustable FSB CPU core voltage.

Dimension

- ATX Form Factor: 30.5(L)x19.2(W)x4 layers PCB

Mounting

- 8 mounting holes.

System Hardware Monitor

- CPU/Power Supply/Chassis Fan Revolution Detect
- CPU Fan Control (the fan will automatically stop when the system enters suspend mode)
- System Voltage Detect
- CPU Overheat Warning.
- Display Actual Current Voltage

Other Features

- Keyboard Password Wake-Up (reserved)
- LAN Wake-Up
- Internal/External Modem Wake-Up
- Suspend to RAM (STR)

1.2 Mainboard Layout

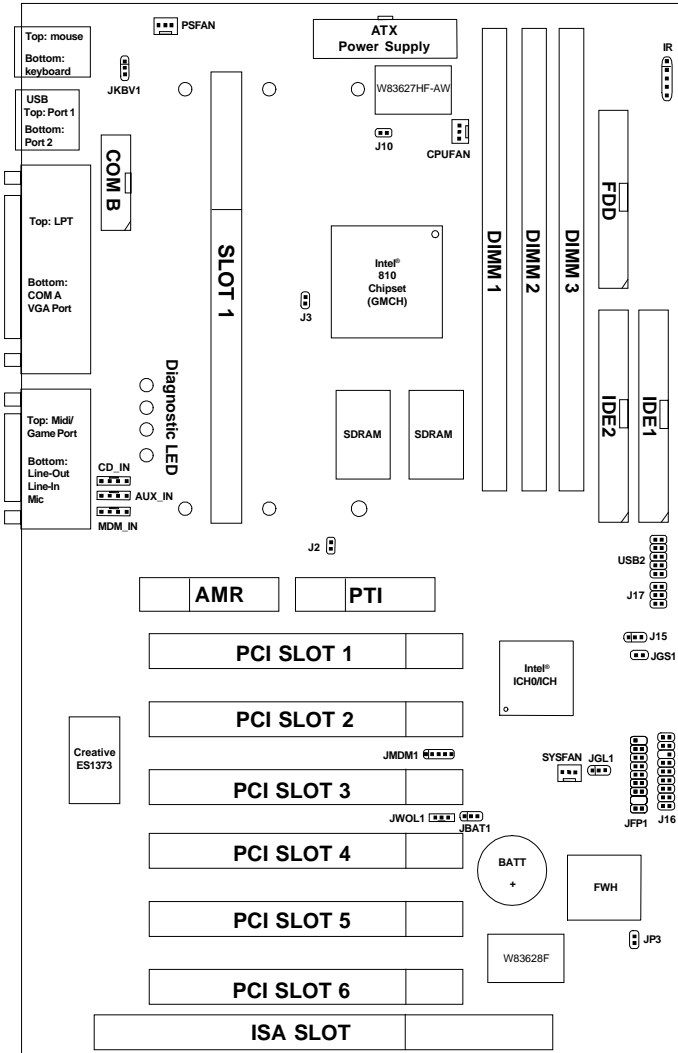

MS-6182 ATX WH8 Mainboard

Chapter 2

HARDWARE INSTALLATION

2.1 Central Processing Unit: CPU

2.1-1 Processor Installation Procedure

Step 1: Install the Retention Mechanism.

Attach the Retention Mechanism to the Mainboard. Push the Plastic lock to secure the Retention Mechanism into the mainboard.

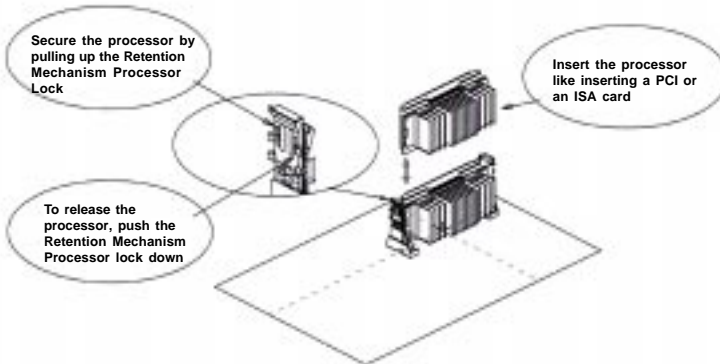

Step 2: Install the Processor.

Insert the Processor like inserting a PCI or an ISA card.

Step 3: Lock the Processor.

Lock the processor by pulling up the Retention Mechanism processor lock shown above.

Note: The Retention Mechanism processor lock can only lock S.E.C.C. 2 and S.E.P.P. processor.

2.1-2 CPU Core Speed Derivation Procedure



The mainboard CPU Bus Frequency can be set through BIOS setup

if CPU Clock = 66MHz
 Core/Bus ratio = 3.5
then CPU core speed = Host Clock x Core/Bus ratio
 = 66MHz x 3.5
 = 233MHz

2.1-3 Overclocking Jumper: J2

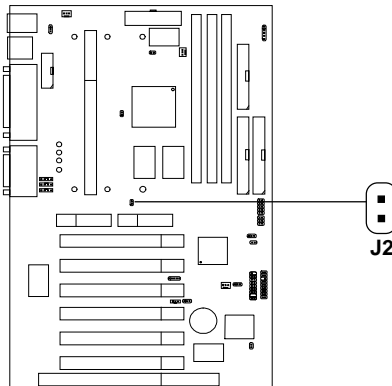
Overclocking is operating a CPU/Processor beyond its specified frequency. J2 jumper is used for overclocking.



J2	Function
 Short	Automatically detect CPU Bus Frequency
 Open	Allows CPU overclocking. Set 66MHz to 100Mhz

2.1-4 Fan Power Connector: CPUFAN/PSEFAN/SYSFAN

These connectors support system cooling fan with + 12V. It supports three pin head connector. When connecting the wire to the connector, always take note that the red wire is the positive and should be connected to the +12V, the black wire is Ground and should be connected to GND. If your mainboard has System Hardware Monitor chipset on-board, you must use a specially designed fan with speed sensor to take advantage of this function.

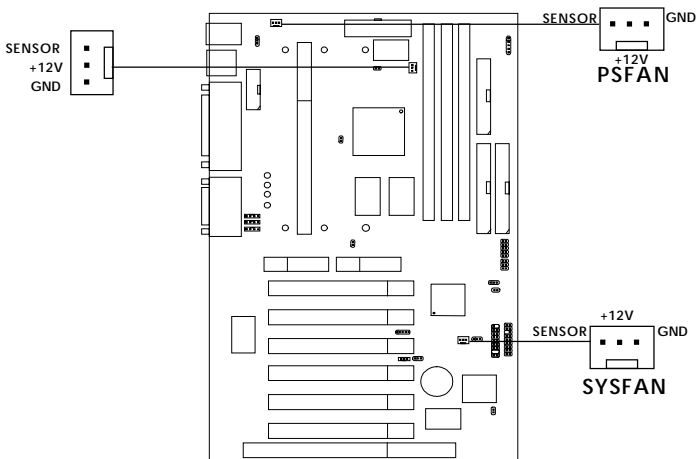

PSFAN: Power Supply Fan

CPUFAN: Processor Fan

SYSFAN: System(Chassis) Fan

For fans with fan speed sensor, every rotation of the fan will send out 2 pulses. System Hardware Monitor will count and report the fan rotation speed.

Note:

1. Always consult vendor for proper CPU cooling fan.
2. CPU FAN supports the FAN control. You can install PC Alert utility. This will automatically control the CPU FAN Speed according to the actual CPU temperature.

2.2 Clear CMOS Jumper: JBAT1

A battery must be used to retain the mainboard configuration in CMOS RAM. Short 1-2 pins of JBAT1 to store the CMOS data.

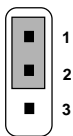
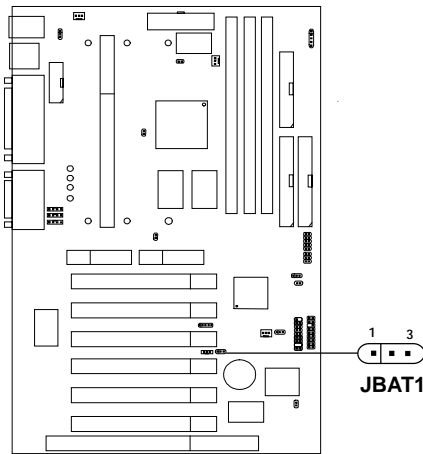

Keep Data

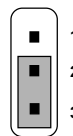

Clear Data

Note: You can clear CMOS by shorting 2-3 pin, while the system is off. Then, return to 1-2 pin position. Avoid clearing the CMOS while the system is on, it will damage the mainboard. Always unplug the power cord from the wall socket.

2.3 Memory Installation

2.3-1 Memory Bank Configuration

The mainboard supports a maximum memory size of 256MB(64-bit technology) or 512MB(128-bit technology for SDRAM: It provides three 168-pin **unbuffered** DIMMs (Double In-Line Memory Module) sockets. It supports 8 MB to 128 Mbytes DIMM memory module.

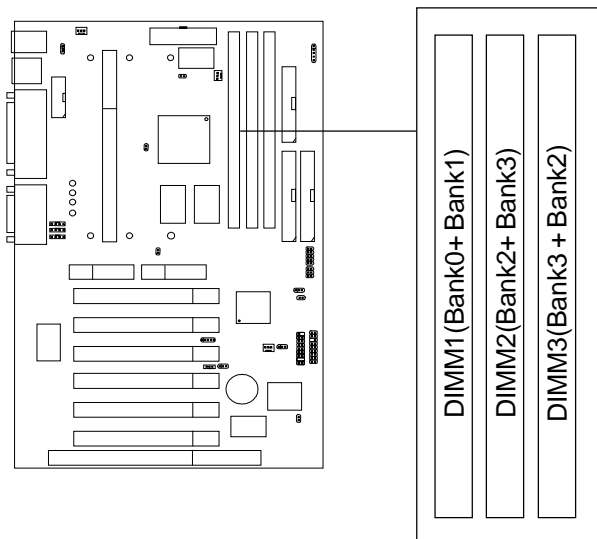

NOTE: When you install Double Bank DIMM or DIMM 2, DIMM 3 will not be functional and vice versa. To make use of DIMM 2 and DIMM 3, insert a Single Bank DIMM to each of them. It is recommended that you use the same type or model of SDRAM.

DIMM 2	DIMM 3
D	X
S	S
X	D

S: Single Bank DIMM
 D: Double Bank DIMM
 X: Cannot be installed

If you're going to use only one(1) Single Bank DIMM, install the Single Bank DIMM on DIMM 2. Using DIMM 3 to install one Single Bank DIMM will not be functional.

2.3-2 Memory Installation Procedures

A. How to install a DIMM Module

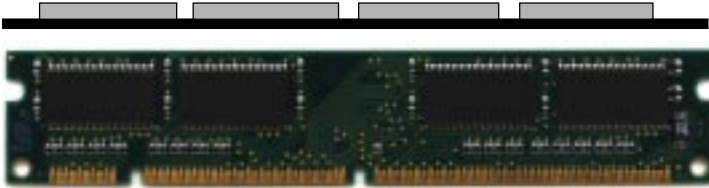

Single Sided DIMM

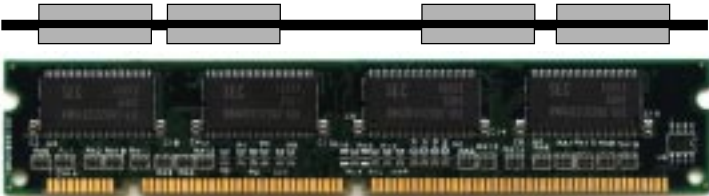

Double Sided DIMM

1. The DIMM slot has 2 Notch Keys “VOLT and DRAM”, so the DIMM memory module can only fit in one direction.
2. Insert the DIMM memory module vertically into the DIMM slot. Then push it in.

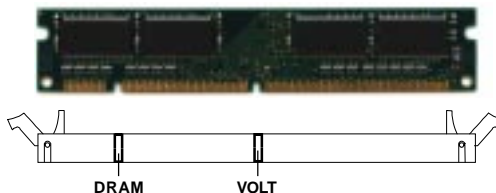

3. The plastic clip at the side of the DIMM slot will automatically close.

2.3-3 Memory Population Rules

1. Supports only SDRAM DIMM.
2. To operate properly, at least one 168-pin DIMM module must be installed.
3. This mainboard supports Table Free memory, so memory can be installed on DIMM1, DIMM 2 or DIMM 3 in any order.
4. Supports 3.3 volt DIMM.
5. The DRAM addressing and the size supported by the mainboard is shown below:

Table 2.3-1 SDRAM Memory Addressing

DRAM Tech.	DRAM Density & Width	DRAM Addressing	Address Size		MB/DIMM	
			Row	Column	Single no. Side(S) pcs.	Double no. Side(D) pcs.
16M	1Mx16	ASYM	11	8	8MBx4	16MBx8
	2Mx8	ASYM	11	9	16MBx8	32MBx16
64M	2Mx32	ASYM	11	9	32MBx2	64MBx4
	2Mx32	ASYM	12	8	16MBx2	32MBx4
	4Mx16	ASYM	11	10	32MB	64MB
	4Mx16	ASYM	13	8	32MB	64MB
	8Mx8	ASYM	13	9	64MB	128MB
64M	2Mx32	ASYM	11	8	16MB	32MB
	4Mx16	ASYM	12	8	---	---
	8Mx8	ASYM	12	9	---	---

NOTE: Please see page 2-5 for reference.

2.4 Case Connector: JFP1

The Keylock, Power Switch, Reset Switch, Power LED, Speaker, and HDD LED are all connected to the JFP1 connector block.

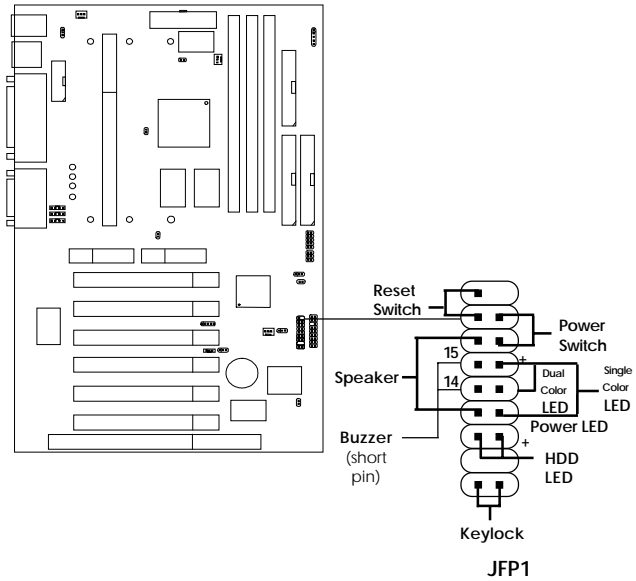

2.4-1 Power Switch

Connect to a 2-pin push button switch. This switch has the same feature with JRMS1.

2.4-2 Reset Switch

Reset switch is used to reboot the system rather than turning the power ON/OFF. Avoid rebooting while the HDD LED is lit. You can connect the Reset switch from the system case to this pin.

2.4-3 Power LED

The Power LED is lit while the system power is on. Connect the Power LED from the system case to this pin. There are two types of LED that you can use: 3-pin single color LED or 2-pin dual color LED(ACPI request).

- a. 3 pin single color LED connect to pin 4, 5, & 6. This LED will lit when the system is on.
- b. 2 pin dual color LED connect to pin 5 & 6.
GREENColor: Indicate the system is in full on mode.
ORANGEColor: Indicate the system is in suspend mode.

2.4-4 Speaker

Speaker from the system case is connected to this pin.

If on-board Buzzer is available:

Short pin 14-15: On-board Buzzer Enabled.

Open pin 14-15: On-board Buzzer Disabled.

2.4-5 HDD LED

HDD LED shows the activity of a hard disk drive. Avoid turning the power off while the HDD led is lit. You can connect the HDD LED from the system case to this pin.

2.4-6 Keylock

Keylock allows you to disable the keyboard for security purposes. You can connect the keylock to this pin.

2.5 Floppy Disk Connector: FDD

The mainboard also provides a standard floppy disk connector FDD that supports 360K, 720K, 1.2M, 1.44M and 2.88M floppy disk types. This connector supports the provided floppy drive ribbon cables.

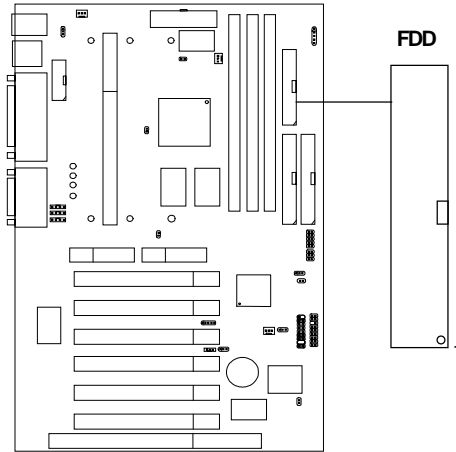

2.6 Hard Disk Connectors: IDE1 & IDE2

The mainboard has a 32-bit Enhanced PCI IDE and Ultra DMA/66 (ICH)/ Ultra DMA/33(ICH0) Controller that provides PIO mode 0~4, Bus Master, and Ultra DMA/33 function. It has two HDD connectors IDE1 (primary) and IDE2 (secondary). You can connect up to four hard disk drives, CD-ROM, 120MB Floppy (reserved for future BIOS) and other devices to IDE1 and IDE2. These connectors support the provided IDE hard disk cable.

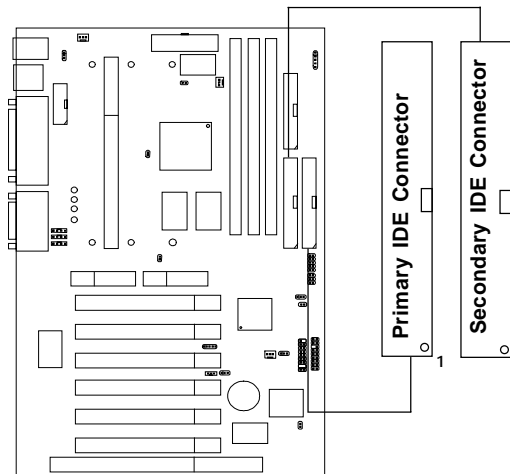

IDE1(Primary IDE Connector)

The first hard drive should always be connected to IDE1. IDE1 can connect a Master and a Slave drive. You must configure second hard drive to Slave mode by setting the jumper accordingly.

IDE2(Secondary IDE Connector)

IDE2 can also connect a Master and a Slave drive.

2.7 Power Supply

2.7-1 ATX 20-pin Power Connector: JPWR1

This connector supports the power button on-board. Using the ATX power supply, functions such as Modem Ring Wake-Up and Soft Power Off are supported by this mainboard. This power connector supports instant power on function which means that system will boot up instantly when the power connector is inserted on the board.

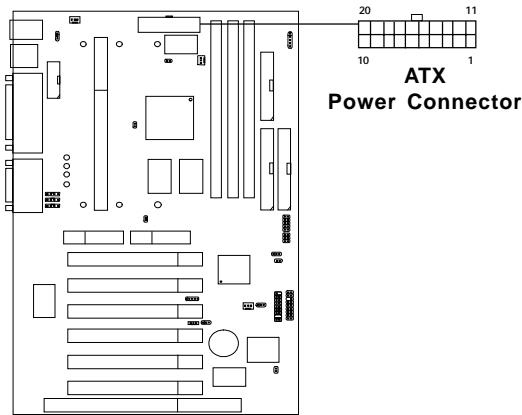

PIN DEFINITION

PIN	SIGNAL	PIN	SIGNAL
1	3.3V	11	3.3V
2	3.3V	12	-12V
3	GND	13	GND
4	5V	14	PS_ON
5	GND	15	GND
6	5V	16	GND
7	GND	17	GND
8	PW_OK	18	-5V
9	5V_SB	19	5V
10	12V	20	5V

Warning: Since the mainboard has the instant power on function, make sure that all components are installed properly before inserting the power connector to ensure that no damage will be done.

2.8 IrDA Infrared Module Connector: IR

The mainboard provides one 5-pin infrared (IR) connector for IR modules. This connector is for optional wireless transmitting and receiving infrared module. You must configure the setting through the BIOS setup to use the IR function. FIR and Consumer IR are reserved functions.

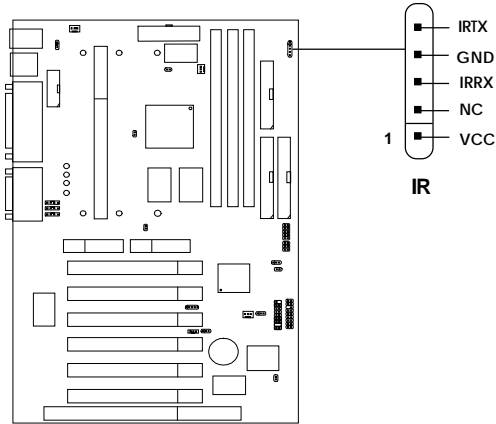

2.9 Serial Port Connectors: COM A and COM B

The mainboard has a 9-pin male DIN connector for serial port COM A. This port is a 16550A high speed communication port that send/receive 16 bytes FIFOs. You can attach a mouse or a modem cable directly into this connector.

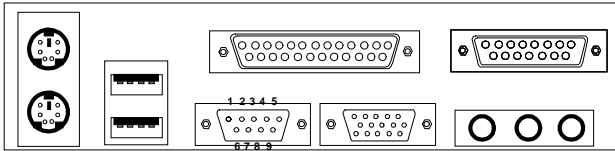

COM 1

Serial Port (9-pin Male)

PIN DEFINITION

PIN	SIGNAL
1	DCD (Data Carry Detect)
2	SIN (Serial In or Receive Data)
3	SOUT (Serial Out or Transmit Data)
4	DTR (Data Terminal Ready)
5	GND
6	DSR (Data Set Ready)
7	RTS (Request To Send)
8	CTS (Clear To Send)
9	RI (Ring Indicate)

Note: There’s another serial port connector (COM B), which is located on the mainboard. Connect a serial port 9-pin male port into this connector.

2.10 Parallel Port Connector: LPT1

The mainboard provides a 25 pin female centronic connector for LPT. A parallel port is a standard printer port that also supports Enhanced Parallel Port(EPP) and Extended capabilities Parallel Port(ECP). See connector and pin definition below:

Parallel Port (25-pin Female)

LPT 1

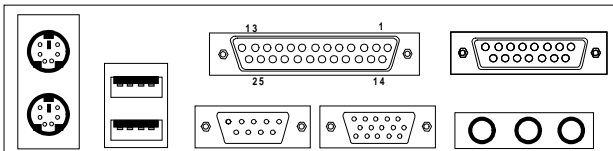

PIN DEFINITION

PIN	SIGNAL	PIN	SIGNAL
1	STROBE	14	AUTO FEED#
2	DATA0	15	ERR#
3	DATA1	16	INIT#
4	DATA2	17	SLIN#
5	DATA3	18	GND
6	DATA4	19	GND
7	DATA5	20	GND
8	DATA6	21	GND
9	DATA7	22	GND
10	ACK#	23	GND
11	BUSY	24	GND
12	PE	25	GND
13	SELECT		

2.11 Mouse Connector: JKBS1

The mainboard provides a standard PS/2[®] mouse mini DIN connector for attaching a PS/2[®] mouse. You can plug a PS/2[®] mouse directly into this connector. The connector location and pin definition are shown below:

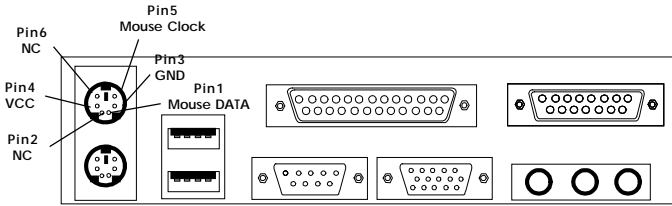

PS/2 Mouse (6-pin Female)

2.12 Keyboard Connector: JKBS1

The mainboard provides a standard PS/2[®] keyboard mini DIN connector for attaching a keyboard. You can plug a keyboard cable directly to this connector.

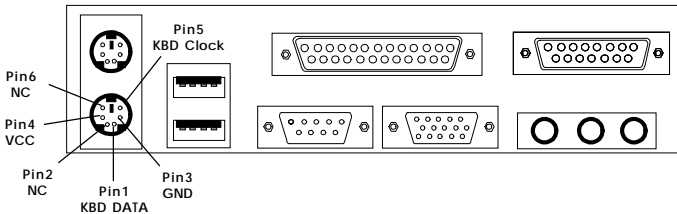

PS/2 Keyboard (6-pin Female)

2.13 Joystick/Midi Connectors

You can connect joystick or game pad to this connector.

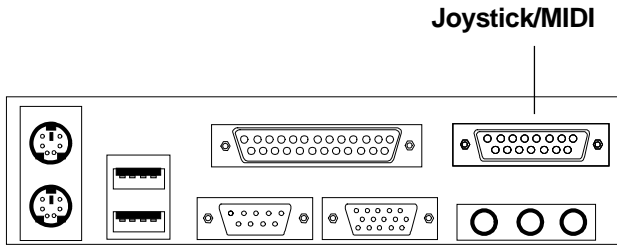

2.14 Audio Port Connectors

Line Out is a connector for Speakers or Headphones. **Line In** is used for external CD player, Tape layer, or other audio devices. **Mic** is a connector for the microphones.

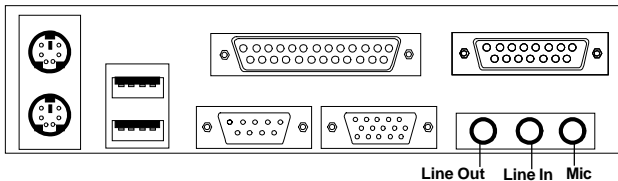

1/8" Stereo Audio Connectors

2.15 USB Connectors

The mainboard provides a **UHCI(Universal Host Controller Interface) Universal Serial Bus root** for attaching USB devices like: keyboard, mouse and other USB devices. You can plug the USB device directly to this connector.

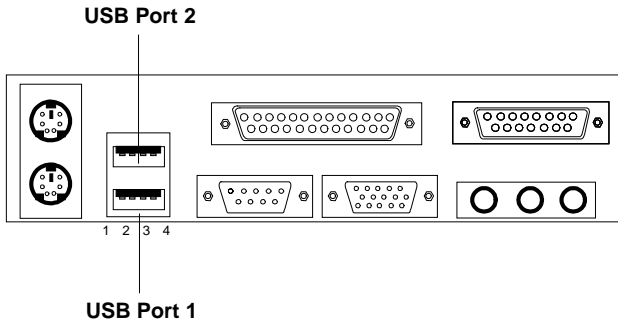

PIN	SIGNAL
1	VCC
2	-Data0
3	GND
4	+Data0

2.16 Power Saving Switch Connector: JGS1

Attach a power saving switch to **JGS1**. When the switch is pressed, the system immediately goes into suspend mode. Press any key and the system wakes up.

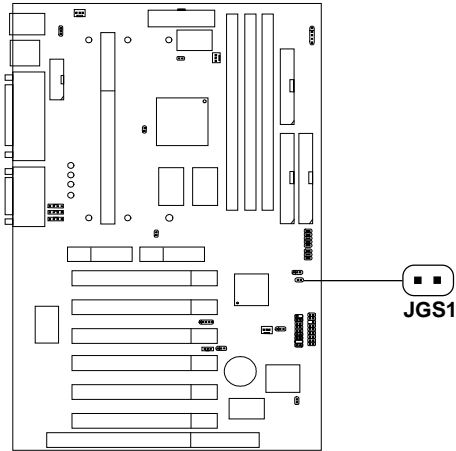

2.17 Power Saving LED Connector: JGL1

JGL1 can be connected with a LED. When the 2-pin LED is connected to JGL1, the light will turn green, when system is On. During sleep mode, the 2-pin LED will change color from Green to Orange.

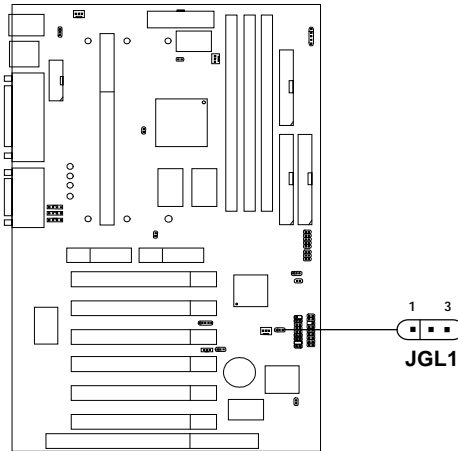

2.18 Wake-Up on LAN Connector: JWOL1

The JWOL1 connector is for use with LAN add-on cards that supports Wake Up on LAN function. To use this function, you need to set the “Wake-Up on LAN” to enable at the BIOS Power Management Setup.

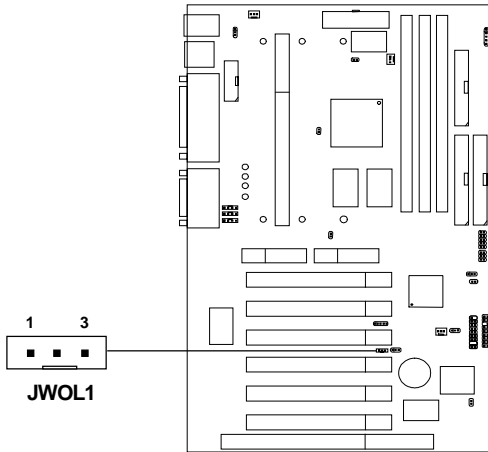

PIN	SIGNAL
1	5VSB
2	GND
3	MP_WAKEUP

Note: LAN wake-up signal is active “high”.

Note: To be able to use this function, you need a power supply that provide enough power for this feature. (Power supply with 750ma 5V Stand-by)

2.19 Modem Wake Up Connector: JMDM1

The JMDM1 connector is for used with Modem add-on card that supports the Modem Wake Up function.

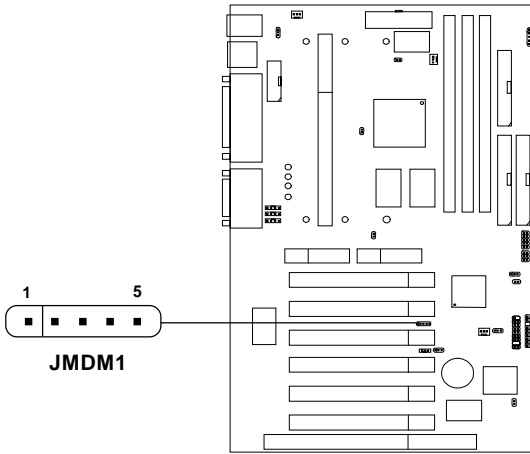

PIN	SIGNAL
1	NC
2	GND
3	MDM_WAKEUP
4	NC
5	5VSB

Note: Modem wake-up signal is active “low”.

Note: To be able to use this function, you need a power supply that provide enough power for this feature. (Power supply with 750ma 5V Stand-by)

2.20 Modem-In: MDM_IN

The connector is for Modem with internal voice connector.

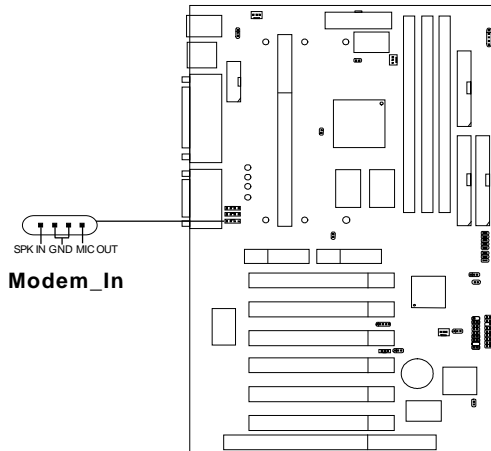

SPK_IN is connected to the Modem Speaker Out connector.

MIC_OUT is connected to the Modem Microphone In connector.

2.21 AUX Line In Connector: AUX_IN

This connector is used for DVD Add on Card with Line In connector.

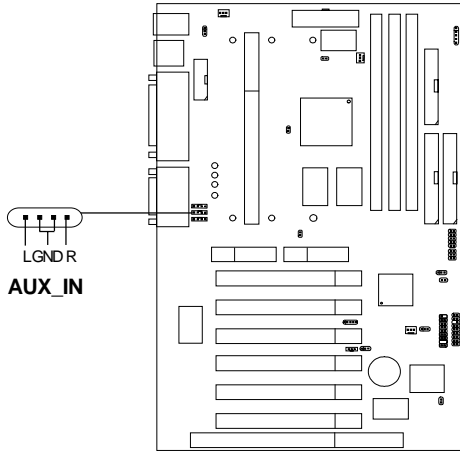

2.22 CD-In Connector: CD_IN

This connector is for CD-ROM audio connector.

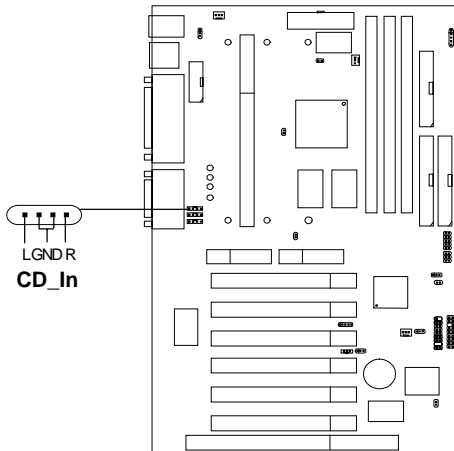

2.23 Keyboard Power: JKBV1

The JKBV1 jumper is for setting keyboard power. This function should be set in the BIOS for the keyboard Wake-up function.

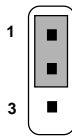
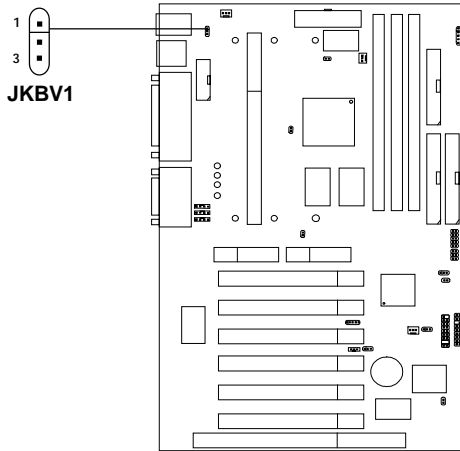

5V Standby
Enable keyboard
power on function

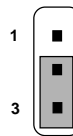

5V (default)
Disable keyboard
power on function

Note: To be able to use this function, you need a power supply that provide enough power for this feature. (750mA power supply with 5V Stand-by)

2.24 Chassis Intrusion Switch Case: J10

This connector is connected to a 2-pin connector chassis switch. If the Chassis is open, the switch will be open. The system will record this status. To clear the warning, you must enter the BIOS setting and clear the status.

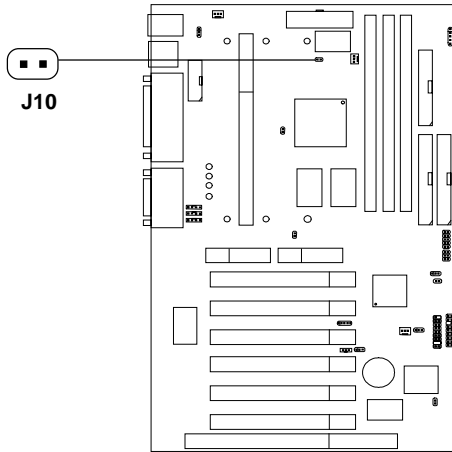

2.25 BIOS Flash Jumper: JP3

This jumper is used to lock/unlock BIOS Flash. This Jumper should be unlock when flashing/programming the BIOS.

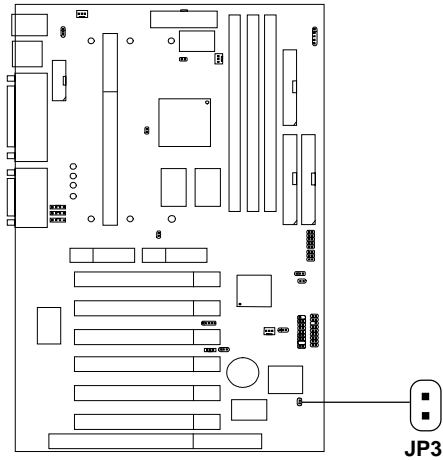

**BIOS Flash
Unlocked**



**BIOS Flash
Locked**

2.26 Case Speaker to Audio Speaker Jumper: J15

This jumper will enable the case speaker/buzzer to be transferred to the Audio speaker.

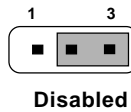
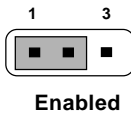
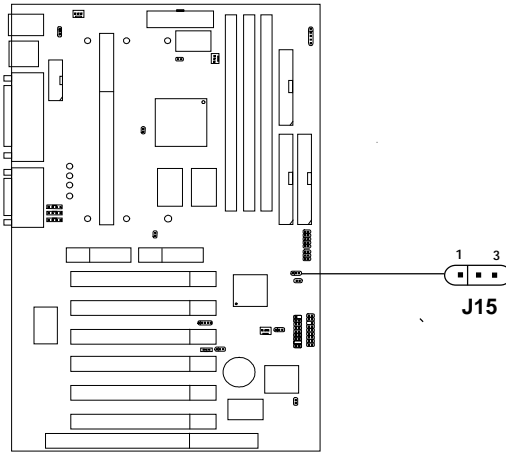

2.27 USB Front Connector

The mainboard provides a **front Universal Serial Bus connector**. This is an optional USB connector for Front Panel.

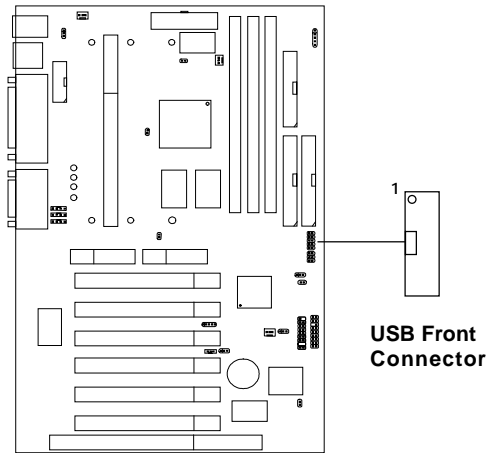

2.28 USB Front Connector Enabled/Disabled Jumper: J17

This jumper is used to Enabled or Disabled the USB Front Connector. If the USB Front connector is set to enabled, the top USB port at the rear I/O panel will be disabled. If the USB Front connector is set to disabled, the USB port at rear I/O panel will both be operational.

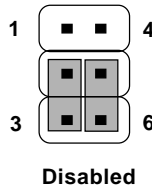
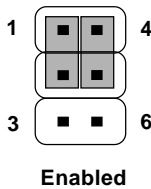
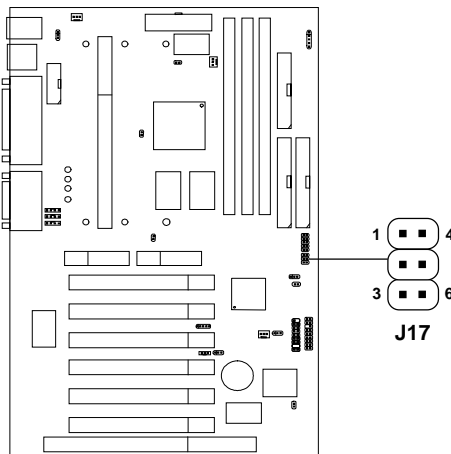

2.29 Front Panel Header: J16 (optional)

J16 is an optional Front Panel Connector.

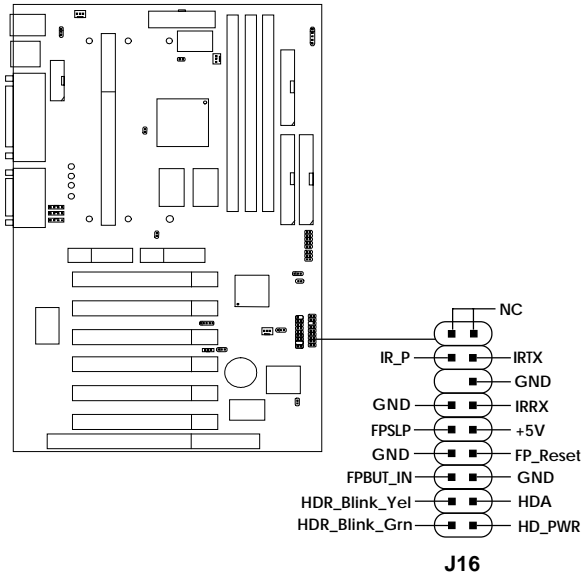

2.30 Diagnostic LED

The mainboard provides a Special Diagnostic LED for users to be aware of their mainboard conditions. The LED helps user determine the problem of the mainboard.

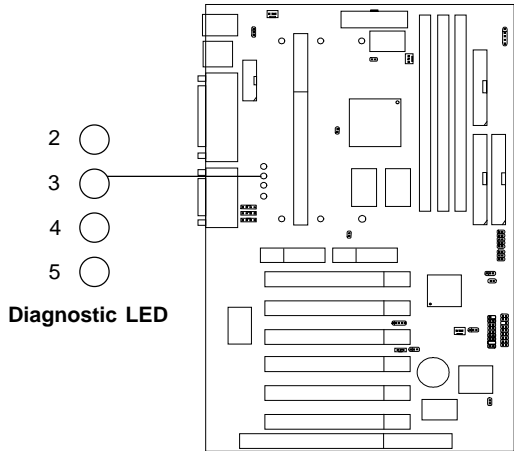

Diagnostic LED Function

Diagnostic LED 5 4 3 2	Description	Possible Problem/ Solution
0 0 0 0	System Power ON. This will start BIOS Initialization	System D-LED will hang here The Processor might be damage or not installed properly Damage/Discharge Lithium Battery
0 0 0 1	Early Chipset Initialization	***
0 0 1 0	Memory Detection Test Testing Onboard memory size	System D-LED will hang here The Memory module might be damage or not installed properly.
0 0 1 1	Decompressing BIOS image to RAM for fast booting.	***
0 1 0 0	Initializing Keyboard Controller	***
0 1 0 1	Testing VGA BIOS This will start writing VGA sign-on messages to the screen.	System D-LED will produce Beep sound The VGA card might be damage or not inserted properly.
0 1 1 0	Processor Initialization This will show information regarding the processor (like brand name, system bus, etc...)	***
0 1 1 1	Testing RTC (Real Time Clock)	Low Lithium Battery
1 0 0 0	Initializing Video Interface This will start detecting CPU clock, checking type of video onboard. Then, detect and initialize the video adapter	***
1 0 0 1	BIOS Sign On This will start showing information about Logo, processor brand name, etc.....	***
1 0 1 0	Testing Base and Extended Memory Testing base memory from 240K to 640K and extended memory above 1MB using various patterns.	***
1 0 1 1	Assign Resource to all ISA	***
1 1 0 0	Initializing Hard Drive Controller This will initialize IDE drive and controller	Check IDE cable for proper installation
1 1 0 1	Initializing Floppy Drive Controller This will initialize Floppy Drive and controller	System D-LED will hang here The Floppy Drive Cable might not be installed properly
1 1 1 0	Boot Attempt This will set low stack and boot via INT19h.	***
1 1 1 1	Operating System Booting.	***

1 = GREEN 0 = RED

*** Check local Vendor for possible internal mainboard problem.

2.31 TOP TECH. II: J3 (Optional)

This is used to check the AGP card or BX chipset temperature. The J3 is a 2-pin connector which can be inserted with a 20cm length thermistor. It is located near the chipset heatsink that monitors the chipset temperature. The BIOS setup for “TOP TECH. II” should be set to enabled.

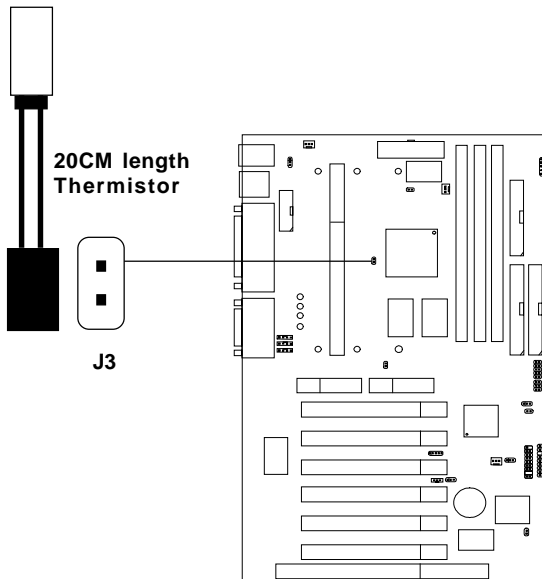

2.32 AMR

The Audio/Modem Riser specification is an open industry-standard specification that defines a hardware scalable Original Equipment Manufacturer (OEM) mainboard riser board and interface, which supports both audio and modem.

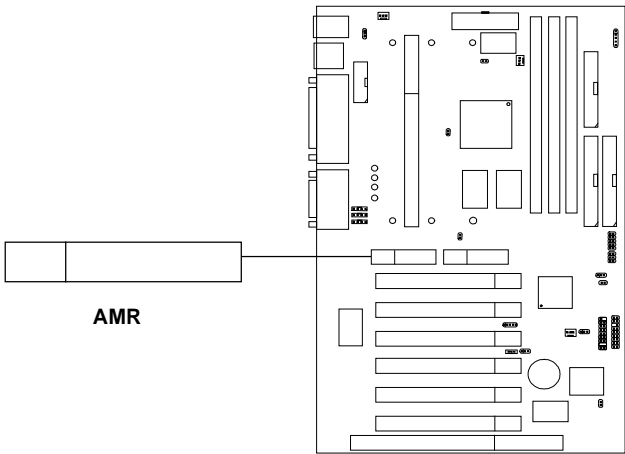

2.33 PTI

The Panel link/TV-Out Interface (PTI) is a MSI in-house designed which supportd either Panel link or TV-out function. To be able utilize both AMR and PTI simultaneously you need to use MSI product like MS-5965 & MS-5966 or MS-5964 & MS-5966.

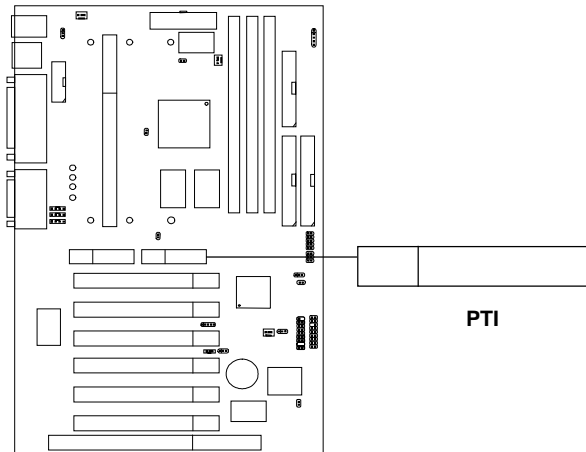

Note: If there is Creative Hardware Audio Onboard and you want to use the MR (Modem Riser) card. Please set the CODAC to primary CODAC which is located on the MR card.

Chapter 3

AWARD® BIOS SETUP

Award® BIOS ROM has a built-in Setup program that allows users to modify the basic system configuration. This type of information is stored in battery-backed RAM (CMOS RAM), so that it retains the Setup information when the power is turned off.

3.1 Entering Setup

Power on the computer and press immediately to allow you to enter Setup. The other way to enter Setup is to power on the computer. When the below message appears briefly at the bottom of the screen during the POST (Power On Self Test), press key or simultaneously press <Ctrl>, <Alt>, and <Esc> keys.

TO ENTER SETUP BEFORE BOOT, PRESS <CTRL-ALT-ESC>
OR KEY

If the message disappears before you respond and you still wish to enter Setup, restart the system to try again by turning it OFF then ON or pressing the “RESET” button on the system case. You may also restart by simultaneously pressing <Ctrl>, <Alt>, and <Delete> keys. If you do not press the keys at the correct time and the system does not boot, an error message will be displayed and you will again be asked to,

PRESS <F1> TO CONTINUE, <CTRL-ALT-ESC>
OR TO ENTER SETUP

3.2 Getting Help

Main Menu

The on-line description of the highlighted setup function is displayed at the bottom of the screen.

Status Page Setup Menu/Option Page Setup Menu

Press F1 to pop up a small help window that describes the appropriate keys to use and the possible selections for the highlighted item. To exit the Help Window, press <Esc>.

Advanced Chipset Features

Use this menu to change the values in the chipset registers and optimize your system's performance.

Integrated Peripherals

Use this menu to specify your settings for integrated peripherals.

Power Management Setup

Use this menu to specify your settings for power management.

PnP/PCI Configuration

This entry appears if your system supports PnP/PCI.

PC Health Status

This entry shows your PC health status.

Frequency/Voltage Control

Use this menu to specify your settings for frequency/voltage control.

Load Fail-Safe Defaults

Use this menu to load the BIOS default values for the minimal/stable performance for your system to operate.

Load Optimized Defaults

Use this menu to load the BIOS default values that are factory settings for optimal performance system operations.

Supervisor/User Password

Use this menu to set User and Supervisor Passwords.

Save & Exit Setup

Save CMOS value changes to CMOS and exit setup.

Exit Without Saving

Abandon all CMOS value changes and exit setup.

3.4 Standard CMOS Setup

The items in Standard CMOS Setup Menu are divided into 10 categories. Each category includes no, one or more than one setup items. Use the arrow keys to highlight the item and then use the <PgUp> or <PgDn> keys to select the value you want in each item.

CMOS Setup Utility - Copyright(C) 1984-1999 Award Software
Standard CMOS Setup

Date(mm:dd:yy):	Fri, Feb 28,1999	Item Help
Time(hh:mm:ss):	00:00:00	
IDE Primary Master	Press Enter 2557MB	Menu Level >
IDE Primary Slave	Press Enter None	
IDE Secondary Master	Press Enter None	
IDE Secondary Slave	Press Enter None	
Drive A	1.44M, 3.5in.	
Drive B	None	
Video	EGA/VGA	
Halt On	All, But Keyboard	
Based Memory	640K	
Extended Memory	63488K	
Total Memory	64512K	
↑↓ →← Move Enter:Select +/-/PU/PD:Value F10:Save ESC:Exit F1:General Help F5:Previous Values F6:Fail-safe defaults F7:Optimized Defaults		

Date

The date format is <day><month> <date> <year>.

Day	Day of the week, from Sun to Sat, determined by BIOS. Read-only.
month	The month from Jan. through Dec.
date	The date from 1 to 31 can be keyed by numeric function keys.
year	The year, depends on the year of the BIOS

Time

The time format is <hour> <minute> <second>.

PrimaryMaster/PrimarySlave**SecondaryMaster/Secondary Slave**

Press PgUp/<+> or PgDn/<-> to select Manual, None, Auto type.

Note that the specifications of your drive must match with the drive table. The hard disk will not work properly if you enter improper information for this category. If your hard disk drive type is not matched or listed, you can use Manual to define your own drive type manually.

If you select Manual, related information is asked to be entered to the following items. Enter the information directly from the keyboard. This information should be provided in the documentation from your hard disk vendor or the system manufacturer.

If the controller of HDD interface is SCSI, the selection shall be
“None”.

If the controller of HDD interface is CD-ROM, the selection shall be
“None”.

Access Mode	The settings are Auto, Normal, Large,LBA.
Cylinder	number of cylinders
Head	number of heads
Precomp	write precom
Landing Zone	landing zone
Sector	number of sectors

3.5 Advanced BIOS Features

CMOS Setup Utility - Copyright(C) 1984-1999 Award Software
Advanced BIOS Features

Anti-Virus Protection	Disabled	Item Help
CPU Internal Cache	Enabled	
External Cache	Enabled	Menu Level >
CPU L2 Cache ECC Checking	Enabled	
Processor Number Feature	Enabled	
Quick Power On Self Test	Disabled	
First Boot device	Floppy	
Second Boot device	HDD-0	
Third Boot device	LS/Zip	
Boot other device	Enabled	
Swap Floppy Drive	Disabled	
Boot Up Floppy Seek	Disabled	
Boot Up Numlock Status	Off	
Gate A20 Option	Fast	
Typeomatic Rate Setting	Disabled	
Typeomatic Rate (Chars/Sec)	6	
Typeomatic Delay (Msec)	250	
Security Option	Setup	
OS Select for DRAM > 64MB	Non-OS2	
Report No FDD for Win 95	No	
↑ ↓ → ← Move Enter:Select +/-/PU/PD:Value F10:Save ESC:Exit F1:General Help F5:Previous Values F6:Fail-safe defaults F7:Optimized Defaults		

Anti-Virus Protection

Allows you to choose the VIRUS Warning feature for IDE Hard Disk boot sector protection. If this function is enabled and someone attempt to write data into this area, BIOS will show a warning message on screen and alarm beep.

Disable(default) No warning message to appear when anything attempts to access the boot sector or hard disk partition table.

Enable Activates automatically when the system boots up causing a warning message to appear when anything attempts to access the boot sector of hard disk partition table.

CPU Internal Cache

The default value is Enabled.

Enabled (default) Enable cache

Disabled Disable cache

Note: The internal cache is built in the processor.

External Cache

Choose Enabled or Disabled. This option enables the level 2 cache memory.

CPU L2 Cache ECC Checking

Choose Enabled or Disabled. This option enables the level 2 cache memory ECC(error check correction).

Processor Number Feature

This option is for Pentium III processor. During Enabled, this will check the CPU Serial number. Disable this option if you don't want the system to know the Serial number.

Quick Power On Self Test

This category speeds up Power On Self Test (POST) after you power on the computer. If this is set to Enabled, BIOS will shorten or skip some check items during POST.

Enabled Enable quick POST

Disabled (default) Normal POST

First/Second/Third/Other Boot Device

The BIOS attempts to load the operating system from the devices in the sequence selected in these items. The settings are Floppy, LS/ZIP, HDD-0/HDD-1/HDD-2/HDD-3, SCSI, CDROM, LAN, and Disabled.

Swap Floppy Drive

Switches the floppy disk drives between being designated as A and B. Default is Disabled.

Boot Up Floppy Seek

During POST, BIOS will determine if the floppy disk drive installed is 40 or 80 tracks. 360K type is 40 tracks while 760K, 1.2M and 1.44M are all 80 tracks.

Boot Up NumLock Status

The default value is On.

On (default) Keypad is numeric keys.

Off Keypad is arrow keys.

Gate A20 Option

Normal The A20 signal is controlled by keyboard controller or chipset hardware.

Fast(default) The A20 signal is controlled by port 92 or chipset specific method.

Typematic Rate Setting

Key strokes repeat at a rate determined by the keyboard controller. When enabled, the typematic rate and typematic delay can be selected. The settings are: Enabled/Disabled.

Typematic Rate (Chars/Sec)

Sets the number of times a second to repeat a key stroke when you hold the key down. The settings are: 6, 8, 10, 12, 15, 20, 24, 30.

Typematic Delay (Msec)

Sets the delay time after the key is held down before it begins to repeat the keystroke. The settings are: 250, 500, 750, 1000.

Security Option

This category allows you to limit access to the system and Setup, or just to Setup.

System The system will not boot and access to Setup will be denied if the correct password is not entered at the prompt.

Setup(default) The system will boot, but access to Setup will be denied if the correct password is not entered at the prompt.

OS Selection for DRAM > 64MB

Allows OS2® to be used with > 64 MB of DRAM. Settings are Non-OS/2 (default) and OS2. Set to OS/2 if using more than 64MB and running OS/2®.

Report No FDD For Win 95

Whether report no FDD for Win 95 or not. The settings are: Yes, No.

3.6 Advanced Chipset Features

The Advanced Chipset Features Setup option is used to change the values of the chipset registers. These registers control most of the system options in the computer.

Choose the “ADVANCED CHIPSET FEATURES” from the Main Menu and the following screen will appear.

CMOS Setup Utility - Copyright(C) 1984-1999 Award Software
Advanced Chipset Features

<pre> SDRAM CAS Latency Time 3 SDRAM Cycle Time Tras/Trc 6/8 SDRAM RAS-to-CAS Delay 3 SDRAM RAS Precharge Time 3 System BIOS Cacheable Disabled Video BIOS Cacheable Disabled Memory Hole at 15M-16M Disabled Delayed Transaction Disabled On-Chip Video Window Size 64MB Local Memory Frequency 100MHz * Onboard Display Cache Setting * Initial Display Cache Enabled Cas# Latency 3 Paging Mode Control Close RAS-to-CAS Override by CAS# LT RAS# Timing Slow RAS# Precharge Timing Slow </pre>	<pre> Item Help ----- Menu Level > </pre>
<pre> ↑↓ → ← Move Enter:Select +/-/PU/PD:Value F10:Save ESC:Exit F1:General Help F5:Previous Values F6:Fail-safe defaults F7:Optimized Defaults </pre>	

Note: Change these settings only if you are familiar with the chipset.

SDRAM CAS latency Time

When synchronous DRAM is installed, the number of clock cycles of CAS latency depends on the DRAM timing. The settings are: 2 and 3.

SDRAM Cycle Time *Tras*/*Trc*

Select the number of SCLKs for an access cycle. The settings are: 5/7 and 6/8.

SDRAM RAS-to-CAS Delay

This field lets you insert a timing delay between the CAS and RAS strobe signals, used when DRAM is written to, read from, or refreshed. *Fast* gives faster performance; and *Slow* gives more stable performance. This field applies only when synchronous DRAM is installed in the system. The settings are: 2 and 3.

SDRAM RAS Precharge Time

If an insufficient number of cycles is allowed for the RAS to accumulate its charge before DRAM refresh, the refresh may be incomplete and the DRAM may fail to retain data. *Fast* gives faster performance; and *Slow* gives more stable performance. This field applies only when synchronous DRAM is installed in the system. The settings are: 2 and 3.

System BIOS Cacheable

Selecting *Enabled* allows caching of the system BIOS ROM at F0000h-FFFFFh, resulting in better system performance. However, if any program writes to this memory area, a system error may result. The settings are: Enabled and Disabled.

Video BIOS Cacheable

Select Enabled allows caching of the video BIOS , resulting in better system performance. However, if any program writes to this memory area, a system error may result. The settings are: Enabled and Disabled.

Memory Hole At 15M-16M

You can reserve this area of system memory for ISA adapter ROM. When this area is reserved, it cannot be cached. The user information of peripherals that need to use this area of system memory usually discusses their memory requirements. The settings are: Enabled and Disabled.

Delayed Transaction

The chipset has an embedded 32-bit posted write buffer to support delay transactions cycles. Select *Enabled* to support compliance with PCI specification version 2.1. The settings are: Enabled and Disabled.

On-Chip Video Window Size

Select the on-chip video window size for VGA driver use. The settings are: 32MB, 64MB, Disabled.

Local Memory Frequency

Select the Memory frequency.

3.7 Integrated Peripherals

CMOS Setup Utility - Copyright(C) 1984-1999 Award Software
Integrated Peripherals

OnChip Primary PCI IDE	Enabled	Item Help
OnChip Secondary PCI IDE	Enabled	
IDE Primary Master PIO	Auto	Menu Level >
IDE Primary Slave PIO	Auto	
IDE Secondary Master PIO	Auto	
IDE Secondary Slave PIO	Auto	
IDE Primary Master UDMA	Auto	
IDE Primary Slave UDMA	Auto	
IDE Secondary Master UDMA	Auto	
IDE Secondary Slave UDMA	Auto	
USB Controller	Enabled	
USB Keyboard Support	Disabled	
Init Display First	PCI Slot	
AC97 Audio	Disabled	
AC97 Modem	Enabled	
Init Display First	PCI Slot	
Onboard Audio Device	Enabled	
IDE HDD Block Mode	Enabled	
Power On Function	Any Key	
KB Power On Password	Enter	
Hot Key Power On	Ctrl-F1	
↑ ↓ → ← Move Enter:Select +/-/PU/PD:Value F10:Save ESC:Exit F1:General Help F5:Previous Values F6:Fail-safe defaults F7:Optimized Defaults		
Onboard FDC Controller	Enabled	
Onboard Serial Port 1	3F8/IRQ4	
Onboard Serial Port 2	2F8/IRQ3	
UART Mode Select	Normal	
RxD, TxD Active	Hi, Lo	
IR Transmission Delay	Enabled	
Onboard Parallel Port	378/IRQ7	
Parallel Port Mode	SPP	
EPP Mode Select	EPP 1.7	
ECP Mode use UDMA	3	
PWRON After PWR-Fail	Off	
Game Port Address	Disabled	
Midi Port Address	Disabled	
Midi Port IRQ	5	
Power Status LED	Blinking	

OnChip Primary/Secondary PCI IDE

The integrated peripheral controller contains an IDE interface with support for two IDE channels. Select Enabled to activate each channel separately. The settings are: Enabled and Disabled.

IDE Primary/Secondary Master/Slave PIO

The four IDE PIO (Programmed Input/Output) fields let you set a PIO mode (0-4) for each of the four IDE devices that the onboard IDE interface supports. Modes 0 through 4 provide successively increased performance. In Auto mode, the system automatically determines the best mode for each device. The settings are: Auto, Mode 0, Mode 1, Mode 2, Mode 3, Mode 4.

IDE Primary/Secondary Master/Slave UDMA

Ultra DMA/33 implementation is possible only if your IDE hard drive supports it and the operating environment includes a DMA driver (Windows 95 OSR2 or a third-party IDE bus master driver). If your hard drive and your system software both support Ultra DMA/33 and Ultra DMA/66, select Auto to enable BIOS support. The settings are: Auto, Disabled.

USB Controller

Select *Enabled* if your system contains a Universal Serial Bus (USB) controller and you have USB peripherals. The settings are: Enabled, Disabled.

USB Keyboard Support

Select *Enabled* if your system contains a Universal Serial Bus (USB) controller and you have a USB keyboard. The settings are: Enabled, Disabled.

Init Display First

This item allows you to decide to activate whether PCI Slot or on-chip VGA first. The settings are: PCI Slot, Onboard.

AC97 Audio/Modem

This item allows you to decide to enable/disable the 810 chipset family to support AC97 Audio/Modem. The settings are: Enabled, Disabled.

Init Display First**PCI Slot**

If both PCI VGA card and AGP card are installed, the system will display the PCI VGA card first.

AGP

If both PCI VGA card and AGP card are installed, the system will show the AGP card first.

IDE HDD Block Mode

Block mode is also called block transfer, multiple commands, or multiple sector read/write. If your IDE hard drive supports block mode (most new drives do), select Enabled for automatic detection of the optimal number of block read/writes per sector the drive can support. The settings are: Enabled, Disabled.

Power On Function

This function allows you to select the item to power on the system. The settings are : Any Key, Button Only, Mouse Left, Mouse Right, Password, Hotkey, keyboard 98.

Onboard FDC Controller

Select Enabled if your system has a floppy disk controller (FDD) installed on the system board and you wish to use it. If you install add-on FDC or the system has no floppy drive, select Disabled in this field. The settings are: Enabled and Disabled.

Onboard Serial Port 1/Port 2

Select an address and corresponding interrupt for the first and second serial ports. The settings are: 3F8/IRQ4, 2E8/IRQ3, 3E8/IRQ4, 2F8/IRQ3, Disabled, Auto.

UART Mode Select

This item allows you to determine which InfraRed(IR) function of the onboard I/O chip, this functions uses.

Onboard Parallel Port

Disabled
(3BCH/IRQ7)/
(278H/IRQ5)/
(378H/IRQ7)

There is a built-in parallel port on the on-board Super I/O chipset that provides Standard, ECP, and EPP features. It has the following options:

Disable
3BCH/IRQ7 Line Printer port 0
278H/IRQ5 Line Printer port 2
378H/IRQ7 Line Printer port 1

Onboard Parallel Mode

SPP : Standard Parallel Port
EPP : Enhanced Parallel Port
ECP : Extended Capability Port

**SPP/EPP/ECP/
ECP+EPP**

To operate the onboard parallel port as Standard Parallel Port only, choose “SPP.” To operate the onboard parallel port in the EPP modes simultaneously, choose “EPP.” By choosing “ECP”, the onboard parallel port will operate in ECP mode only. Choosing “ECP + EPP” will allow the onboard parallel port to support both the ECP and EPP modes simultaneously. The ECP mode has to use the DMA channel, so choose the onboard parallel port with the ECP feature. After selecting it, the following message will appear: “ECP Mode Use DMA” At this time, the user can choose between DMA

channels 3 or 1. The onboard parallel port is EPP Spec. compliant, so after the user chooses the onboard parallel port with the EPP function, the following message will be displayed on the screen: "EPP Mode Select." At this time either EPP 1.7 spec. or EPP 1.9 spec. can be chosen.

PWRON After PWR-FAIL

This option will determine how the system will power on after a power failure.

Game Port Address/Midi Port Address

This will determine which Address the Game Port/Midi Port will use.

Power Status LED

This item determines which state the Power LED will use. The settings are Blinking, Dual, and Single. During blinking, the power LED will blink when the system enters the suspend mode. When the mode is in Dual, the power LED will change its color. Choose the single and the power LED will always remain lit.

3.8 Power Management Setup

The Power Management Setup allows you to configure you system to most effectively save energy while operating in a manner consistent with your own style of computer use.

CMOS Setup Utility - Copyright(C) 1984-1999 Award Software
Power Management Setup

ACPI Function	Enabled	Item Help
ACPI Suspend Type	SI(POS)	
Power Management	User Define	Menu Level >
Video Off Method	DPMS	
Video Off In Suspend	Yes	
Suspend Type	Stop Grant	
Modem Use IRQ	3	
Suspend Mode	Disabled	
HDD Power Down	Disabled	
Soft-Off by PWRBTN	Instant-Off	
Wake-Up by PCI Card	Disabled	
Wake-Up on LAN	Disabled	
CPU Thermal-Throtting	62.57%	
Resume By Alarm		
Reload Global Timer Events		
Primary IDE 0	Disabled	
Primary IDE 1	Disabled	
Secondary IDE 0	Disabled	
Secondary IDE 1	Disabled	
FDD, COM, LPT Port	Disabled	
PCI PIRQ[A-D]#	Disabled	
↑↓ →← Move Enter:Select +/-/PU/PD:Value F10:Save ESC:Exit F1:General Help F5:Previous Values F6:Fail-safe defaults F7:Optimized Defaults		

ACPI Function

This item allows you to enable/disable the Advanced Configuration and Power Management (ACPI). The settings are: Enabled and Disabled.

ACPI Suspend Type

This item will set which ACPI suspend type will be used.

Power Management

This category allows you to select the type (or degree) of power saving and is directly related to the following modes:

1. Suspend Mode
2. HDD Power Down

There are three selections for Power Management, two of which have fixed mode settings.

Min. Power Saving	Minimum power management. Suspend Mode = 1 hr., and HDD Power Down = 15 min.
Max. Power Saving	Maximum power management — Suspend Mode = 1 min., and HDD Power Down = 1 min.
User Defined (default)	Allows you to set each mode individually. When not disabled, each of the ranges are from 1 min. to 1 hr. except for HDD Power Down which ranges from 1 min. to 15 min. and disable.

Video Off Method

This determines the manner in which the monitor is blanked.

V/H SYNC+Blank	This selection will cause the system to turn off the vertical and horizontal synchronization ports and write blanks to the video buffer.
Blank Screen	This option only writes blanks to the video buffer.
DPMS (default)	Initial display power management signaling.

Video Off In Suspend

This determines the manner in which the monitor is blanked.
The settings are: Yes and No.

Suspend Type

Select the Suspend Type. The settings are: PWRON Suspend, Stop Grant.

Modem Use IRQ

This determines the IRQ in which the MODEM can use.
The settings are: 3, 4, 5, 7, 9, 10, 11, NA.

Suspend Mode

When enabled and after the set time of system inactivity, all devices except the CPU will be shut off. The settings are: 1/2/4/8/12/20/30/40 Min, 1 Hour, and Disabled.

HDD Power Down

When enabled and after the set time of system inactivity, the hard disk drive will be powered down while all other devices remain active.
The settings are: 1/2/3/4/5/6/7/8/9/10/11/12/13/14/15Min and Disabled.

Soft-Off by PWRBTN

Pressing the power button for more than 4 seconds forces the system to enter the Soft-Off state. The settings are: Delay 4 Sec, Instant-Off.

Wake-Up by PCI Card

This will enable the system to wake up through PCI Card peripheral.
The settings are : Enabled and Disabled.

Wake-Up on LAN

To use this function, you need a LAN add-on card which support power on functions. It should also support the wake-up on LAN jumper (JWOL1).

Enabled	Wake up on LAN supported.
Disabled	Wake up on LAN not supported.

CPU Thermal-Throttling

Select the CPU THRM-Throttling rate. The settings are: 25.0%, 37.5%, 50.0%, 62.5%, 75.0%, 87.5%.

Resume by Alarm

This function is for setting date and time for your computer to boot up. During Disabled, you cannot use this function. During Enabled, choose the Date and Time Alarm:

Date(of month) Alarm	You can choose which month the system will boot up. Set to 0, to boot every day.
Time(hh:mm:ss) Alarm	You can choose what hour, minute and second the system will boot up.

Note: If you have change the setting, you must let the system boot up until it goes to the operating system, before this function will work.

Reload Global Timer Events

Reload Global Timer events are I/O events whose occurrence can prevent the system from entering a power saving mode or can awaken the system from such a mode. In effect, the system remains alert for anything which occurs to a device which is configured as *Enabled*, even when the system is in a power down mode.

Primary IDE 0
Primary IDE 1
Secondary IDE 0
Secondary IDE 1
FDD, COM, LPT Port
PCI PIRQ[A-D]#

3.9 PnP/PCI Configuration Setup

This section describes configuring the PCI bus system. PCI, or **P**ersonal **C**omputer **I**nterconnect, is a system which allows I/O devices to operate at speeds nearing the speed the CPU itself uses when communicating with its own special components. This section covers some very technical items and it is strongly recommended that only experienced users should make any changes to the default settings.

CMOS Setup Utility - Copyright(C) 1984-1999 Award Software
PnP/PCI Configuration Setup

Reset Configuration Data	Disabled	Item Help
Resources Controlled By	Auto	
IRQ Resources	Press Enter	
Memory Resources	Press Enter	Menu Level >
PCI/VGA Palette Snoop	Disabled	
↑ ↓ → ← Move Enter:Select +/-/PU/PD:Value F10:Save ESC:Exit F1:General Help F5:Previous Values F6:Fail-safe defaults F7:Optimized Defaults		

Reset Configuration Data

Normally, you leave this field to Disabled. Select Enabled to reset Extended System Configuration Data (ESCD) when you exit Setup if you have installed a new add-on and the system reconfiguration has caused such a serious conflict that the operating system can not boot. The settings are: Enabled and Disabled .

Resource Controlled By

The Award Plug and Play BIOS has the capacity to automatically configure all of the boot and Plug and Play compatible devices. However, this capability means absolutely nothing unless you are using a Plug and Play operating system such as Windows®95/98. If you set this field to “manual”, choose specific resources by going into each of the sub menu that follows this field (a sub menu is preceded by a “>”). The settings are: Auto(ESCD), Manual.

IRQ Resources

When resources are controlled manually, assign each system interrupt a type, depending on the type of device using the interrupt.

Memory Resources

This sub menu can let you control the memory resource.

PCI/VGA Palette Snoop

Leave this field at *Disabled*. The settings are Enabled, Disabled.

3.10 PC Health Status

This section shows the Status of you CPU, Fan, Warning for overall system status.

CMOS Setup Utility - Copyright(C) 1984-1999 Award Software
 PC Health Status

CPU Warning Temperature	Disabled	Item Help	
Current System Temp	38°C/100°F		
Current CPU1 Temperature	69°C/156°C	Menu Level >	
Current CUFAN1 Speed	0 RPM		
Current CUFAN2 Speed	0 RPM		
Current CUFAN3 Speed	5720 RPM		
IN0 (V)	2.00V		
IN1 (V)	1.47V		
IN2 (V)	3.37V		
+5V	5.02V		
+12V	12.03V		
-12V -	12.28V		
-5V -	5.04V		
VBAT (V)	3.04V		
5VSB (V)	5.77V		
↑ ↓ → ← Move Enter:Select +/-/PU/PD=Value F10:Save ESC:Exit F1:General Help F5:Previous Values F6:Fail-safe defaults F7:Optimized Defaults			

CPU Warning Temperature

During Enabled, this will warn the user when the CPU temperature reach a certain temperature.

**Current System Temp/Current CPU1 Temperature/Current
CPUFAN1/CPUFAN2/CPUFAN3 Speed/IN0/1/3/+5V/+12V/
12V/-5V/VBAT(V)/5VSB(V)**

This will show the CPU/FAN/System voltage chart and FAN Speed.

3.11 Frequency/Voltage Control

This section is for setting CPU Frequency/Voltage Control.

CMOS Setup Utility - Copyright(C) 1984-1999 Award Software
 Frequency/Voltage Control

Auto Detect DIMM/PCI Clk	Enabled	Item Help
CPU Clock/Spread Spectrum	Default	
CPU Ratio	Auto	
Vcore Adjust	2.00 V	
L2 Cache Voltage Control	Disabled	
		Menu Level >
↑ ↓ → ← Move Enter:Select +/-/PU/PD:Value F10:Save ESC:Exit F1:General Help F5:Previous Values F6:Fail-safe defaults F7:Optimized Defaults		

Auto Detect DIMM/PCI CLK

This item allows you to enable/disable auto detect DIMM/PCI Clock. The settings are: Enabled, Disabled.

CPU Clock/Spread Spectrum

This item allows you to set the CPU Clock/Spread Spectrum.

CPU Ratio

This item allows you to select the CPU ratio.

Vcore Adjust

This item allows you to set the CPU Vcore.

L2 Cache Voltage Control

This item allows you to Enabled/Disabled the L2 Cache Voltage Control.

3.12 Load Fail-Safe/Optimized Defaults

Load Fail-Safe Defaults

When you press <Enter> on this item, you get a confirmation dialog box with a message similar to:

Load Fail-Safe Defaults (Y/N) ? N

Pressing 'Y' loads the BIOS default values for the most stable, minimal-performance system operations.

Load Optimized Defaults

When you press <Enter> on this item, you get a confirmation dialog box with a message similar to:

Load Optimized Defaults (Y/N) ? N

Pressing 'Y' loads the default values that are factory settings for optimal performance system operations.

3.13 Set Supervisor/User Password

You can set either supervisor or user password, or both of them. The differences are:

Supervisor password : Can enter and change the options of the setup menus.

User password : Can only enter but do not have the right to change the options of the setup menus. When you select this function, the following message will appear at the center of the screen to assist you in creating a password.

ENTER PASSWORD:

Type the password, up to eight characters in length, and press <Enter>. The password typed now will clear any previously entered password from CMOS memory. You will be asked to confirm the password. Type the password again and press <Enter>. You may also press <Esc> to abort the selection and not enter a password.

To disable a password, just press <Enter> when you are prompted to enter the password. A message will confirm the password will be disabled. Once the password is disabled, the system will boot and you can enter Setup freely.

PASSWORD DISABLED.

When a password has been enabled, you will be prompted to enter it every time you try to enter Setup. This prevents an unauthorized person from changing any part of your system configuration.

Additionally, when a password is enabled, you can also require the BIOS to request a password every time your system is rebooted. This would prevent unauthorized use of your computer.

You determine when the password is required within the BIOS Features Setup Menu and its Security option. If the Security option is set to “System”, the password will be required both at boot and at entry to Setup. If set to “Setup”, prompting only occurs when trying to enter Setup.

Chapter 4

INTEL® 810 INTEGRATED GRAPHICS CONTROLLER

1. Overview

The Intel® 810 Chipset extends Intel's graphics capabilities into the value PC segment by incorporating 2D and 3D capabilities with the memory controller, to provide the industry with complete graphics offerings for every computing segment.

1.1 Intel® 810 Chipset

- Support 4MB Display Cache (optional)
- Support AGP 2X BUS
- 2D & 3D Graphics Accelerator

1.2 System Requirements

This section describes system requirements for the VGA Driver installation and Usage.

Computer	Intel® Celeron™ processor or higher
Monitor	VGA Support, minimum 640x480 resolution
Operating system	DOS 5.0 or higher, Windows® 95/98, Windows® NT 3.51 or 4.0, or OS/2®
CD-ROM	Double Speed or Higher
Chipset	Intel® 810 chipset
VGA BIOS	Version 00.23 or Higher

2. Intel® 810 VGA Driver Setup & Usage Procedures

Insert the CD-title into your CD-ROM drive. This CD will auto-run. This will display installation for VGA driver and sound driver, Intel® 810/820 INF Update (only for Windows® 95/98) and Trend PC-cillin 98. Just click the button for automatic installation for VGA driver.

2.1 Windows® 95/98

If you start Windows® 95/98, this will automatically detect this hardware onboard “Standard PCI Graphics Adapter (VGA)”. You need to click “Next”, then “Finish”. Do not click on the “Cancel”. The driver need these ID.

Note: Before installing the Intel® 810 VGA Driver, you need to install the Intel® 810/820 INF update first.

2.1-1 Display Driver Installation Procedure:

- Step 1:** Insert the provided CD_ROM disk into the CD-ROM drive.
- Step 2:** Look for the CD_ROM drive, double click on the CD_ROM icon. This will show the setup screen.
- Step 3:** Click on “Intel® 810 VGA Driver” icon.
- Step 4:** This will show an installation menu.
- Step 5:** Click on “Display Drivers”.
- Step 6:** Click “OK”.
- Step 7:** This will copy the VGA drivers into the hard drive.
- Step 8:** A message will appear stating you must restart the Windows® 95/98 system, select **yes** to restart.
- Step 9:** After restarting, Windows® 95/98 will show a new display setting.

Note: It is recommended that you restart your computer after every installation of a new driver to prevent any technical problems.

2.2 Windows® NT 4.0

You need to install Windows® NT “Service Pack 3” or higher, before you install Windows® NT driver.

2.2-1 Display Driver Installation Procedure:

- Step 1:** Click **Start** menu and select **Control Panel** from **Settings** group.
- Step 2:** Select **Display** icon.
- Step 3:** Select **Settings** on the Display Properties.
- Step 4:** Select **Display Type**.
- Step 5:** Select **Change** from the **Adapter Type** Area.
- Step 6:** Select **Have Disk** of Change Display.
- Step 7:** Insert the **CD-Title Disk** into CD-ROM Drive.
- Step 8:** When the Install from Disk dialog box appears, look for your CD-ROM drive :**\\SVGA\Intel\810\NT4\WINNT4**
- Step 9:** When the **Change Display** dialog box appears, click **OK**.
- Step 10:** When the Third-party Drivers dialog box appears, click **Yes**.
A message will appear stating that the drivers were successfully installed. Click **OK**. You must now restart Windows® NT 4.0.

-
- Note:** A. You can also use CD autorun to install the VGA NT driver.
B. It is recommended that you restart your computer after every installation of a new driver to prevent any technical problems.
-

2.2-2 Changing resolution, color depth, and refresh rate:

- Step 1:** Click **Start** menu and select **Control Panel** from **Settings** group.
- Step 2:** Select **Display** icon.
- Step 3:** Select **Settings**.
- Step 4:** Select Color Palette to change between 256 color, 65536 colors, and 16777216 colors.
- Step 5:** To select desktop resolution size, go to the Desktop area and use the slide bar to change resolution from 640x480, 800x600, 1024x768, 1152x864, 1280x1024, to 1600x1200.
- Step 6:** Select Test to test the resolution. If the display test screen was good, then select Yes when the Testing Mode dialog box appears. If the display test screen was bad, then select No. Windows® NT will give you an error message.
- Step 7:** Click OK. If the display test screen was good and you select Yes, Windows® NT 4.0 will change the mode without restarting the system.

2.3 AutoCAD, OS/2 and other application. Please refer to “On-Line Manual” in the CD-ROM. You need to install the “Acrobat Reader 3.01” program first.

Chapter 5

ICH/ICH0 AUDIO DRIVER

1. Overview

The ICH AC' 97 digital controller provides the next generation of audio performance to the PC market.

1.1 Features

- PCI Bus Master for fast DMA.
- Fully Compliant with PC97 Power Management Specification.

1.2 System Requirements

This section describes system requirements for the Audio Driver installation and Usage.

Computer	Intel® Celeron™ processor or higher
Operating system	DOS 5.0 or higher, Windows® 95/98, Windows® NT 3.51 or 4.0, or OS/2®
CD-ROM	Double Speed or Higher
Chipset	ICH/ICH0

1.3 Creative® ES1373 (Optional)

1.3-1 Features

- SoundScape WaveTable Synthesizer.
- Full DOS Game Compatibility.
- PCI Bus Master for fast DMA.
- Fully Compliant with PC97 Power Management Specification.

2. Audio Driver Setup & Usage Procedures

Insert the CD-title into your CD-ROM drive. This CD will auto-run. This will display installation for VGA driver and sound driver, Intel® 810/820 INF Update (only for Windows® 95/98) and Trend PC-cillin 98. Just click the button for automatic installation for audio driver.

2.1 Windows® 95/98

If you start Windows® 95/98, this will automatically detect this hardware onboard “PCI Multimedia Audio Device” and “Gameport Joystick”. You need to click “Next”, then “Finish”. Do not click on the “Cancel”. The driver need these ID.

2.1-1 Audio Driver Installation Procedure:

- Step 1:** Insert the provided CD_ROM disk into the CD-ROM drive.
- Step 2:** Look for the CD_ROM drive, double click on the CD_ROM icon. This will show the setup screen.
- Step 3:** Click on “ADI SoundMax Drivers” icon.
- Step 4:** This will copy the audio drivers into the hard drive.
- Step 5:** A message will appear stating you must restart the Windows® 95/98 system, select **yes** to restart.

-
- Note:** A. For Creative® Audio, follow the same procedures except for Step3 “Choose Creative® Sound Drivers”.
- B. It is recommended that you restart your computer after every installation of a new driver to prevent any technical problems.
-

2.2 Windows® NT 4.0

2.2-1 Audio Driver Installation Procedure:

Step 1: Insert the provided CD-ROM disk into the CD-ROM drive.

Step 2: Look for the CD-ROM drive, double click on the CD-ROM icon. This will show the setup screen.

Step 3: Click on “ADI SoundMax Drivers” icon.

Step 4: This will copy the audio drivers into the hard drive.

Step 5: A message will appear stating you must restart the Windows® NT system, select **yes** to restart.

2.2-2 Creative® Audio Driver Installation Procedure:

Step 1: Click **Start** menu and select **Control Panel** from **Settings** group.

Step 2: Select **Multimedia** icon.

Step 3: Click on the **Devices** tab.

Step 4: Click **Add**.

Step 5: Double click on **Unlisted or Updated Driver** in the list.

Step 6: Insert the **CD-ROM Disk** into the CD-ROM Drive.

Step 7: When the Install from Disk dialog box appears, look for your CD-ROM drive :**\Sound\Creative\AudioPCI\Audio\English\Drivers**

Step 8: Click **OK**.

Step 9: Click **OK**.

Step 10: A message will appear stating that the drivers were successfully installed. Click **OK**. You must now restart Windows® NT 4.0.

Note: It is recommended that you restart your computer after every installation of a new driver to prevent any technical problems.
