

## **Chapter 1**

### **INTRODUCTION**

The MICRO ATX BX13 mainboard is a high-performance personal computer mainboard based on the Intel® Pentium® II/III or Coppermine processor. The Intel® Pentium® II/III processor supports MMX™ (Multimedia Extension) technology.

The mainboard uses the highly integrated Intel® 82443BX AGP chipset to support the PCI/ISA and Green standards, and to provide the Host/AGP bridge. The Intel® 82371EB chipset integrates all system control functions such as ACPI (Advanced Configuration and Power Interface). The ACPI provides more Energy Saving Features for the OSPM(OS Direct Power Management) function. The Intel® 82371EB chipset also improves the IDE transfer rate by supporting Ultra DMA 33/66 IDE that transfers data at the rate of 33/66 MB/s.

The mainboard also supports the System Hardware Monitor Controller. Its functions include: CPU /power supply/chassis fan revolution detect, CPU/system voltage monitor, system temperature monitor, chassis intrusion detect and TOP TECH III as an optional function.

## **1.1 Mainboard Features**

### **CPU**

- Slot 1 for Intel® Pentium® II/III or Coppermine processor.
- Supports 233MHz, 266MHz, 300MHz, 333MHz, 350MHz, 400MHz, 450MHz, 500MHz, 600MHz, 677MHz, 700MHz, 733MHz and faster.

### **Chipset**

- Intel® 82443BX/PIIX4E chipset.

### **FSB (Front Side Bus)**

- 66.6MHz, 100MHz and faster clocks are supported.

### **Main Memory**

- Supports eight memory banks using three 168-pin unbuffered DIMM.
- Supports a maximum memory size of 384MB (8M x 8) or 768MB (16M x 4) registered DIMM only.
- Supports ECC (1-bit Error Code Correct) function.
- Supports 3.3v SDRAM DIMM.

### **Slots**

- One AGP slot.
  - AGP specification compliant
  - AGP 66/133MHz 3.3v device support
- Five 32-bit Master PCI Bus slots and two 16-bit ISA Bus slots (wherein one slot is shared).  
\*See Chapter 2-27 for further details on PCI slots.
- Supports 3.3v/5v PCI bus Interface.

### **On-Board IDE**

- An IDE controller on the Intel® PIIX4E PCI Chipset provides IDE HDD/CD-ROM with PIO, Bus Master and Ultra DMA/33 operation modes.
  - An IDE controller on the PDC 20262 Chipset provides IDE HDD/CD-ROM with PIO, Bus Master and Ultra DMA/66 operation modes.
  - Both can connect up to four IDE devices.
-

**On-Board Peripherals**

- On-Board Peripherals include:
  - 1 floppy port supports 2 FDD with 360K, 720K, 1.2M, 1.44M and 2.88Mbytes.
  - 2 serial port (COM A + COM B)
  - 1 parallel port supports SPP/EPP/ECP mode
  - 2 USB ports
  - 1 IrDA connector for SIR.

**BIOS**

- The mainboard BIOS provides “Plug & Play” BIOS which detects the peripheral devices and expansion cards of the board automatically.
- The mainboard provides a Desktop Management Interface(DMI) function which records your mainboard specifications.
- ACPI(Advanced Configuration and Power Interface) feature.
- Anti-Bios virus function.

**Dimension**

- ATX Form Factor : 30.4cm(L) x 20.7cm(W) x 4 layers PCB

**Mounting**

- 6 mounting holes.

**System Hardware Monitor**

- CPU/Power Supply/Chassis Fan Revolution Detect
- CPU Fan Control detects the CPU temperature, then determine the FAN SPEED, which utilizes PC Alert program (the fan will automatically stop when the system enters suspend mode)
- System Voltage Detect
- Added 5VSB and Battery Voltage Detect
- CPU Overheat Warning.
- Display Actual Current Voltage
- Chassis Intrusion

**Other Features**

- Keyboard Password Wake-Up
- LAN Wake-Up
- Internal/External Modem Wake-Up
- Suspend To DRAM (5V stand by Power Supply with 1A )
- 6 PCI Slot Master

## 1.2 Mainboard Layout

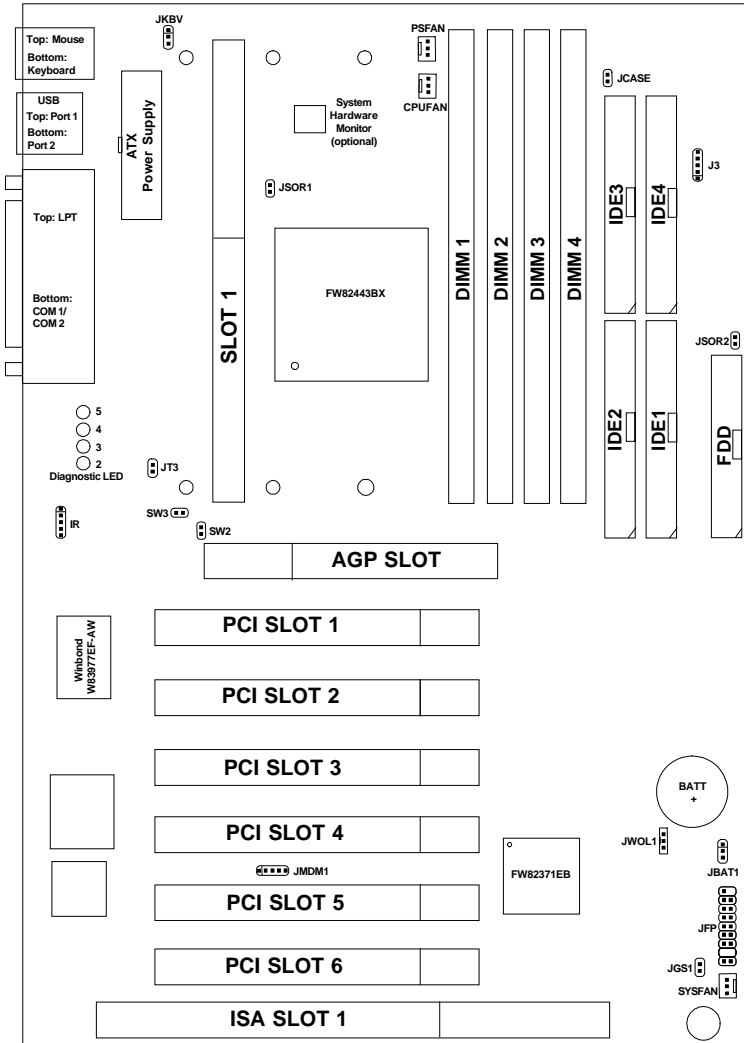

**MS-6163 ATX BX13 Mainboard**

## Chapter 2

### HARDWARE INSTALLATION

#### 2.1 Central Processing Unit: CPU

##### 2.1-1 Processor Installation Procedure

**Step 1:** Install the Retention Mechanism.

Attach the Retention Mechanism to the Mainboard. Push the Plastic lock to secure the Retention Mechanism into the mainboard.

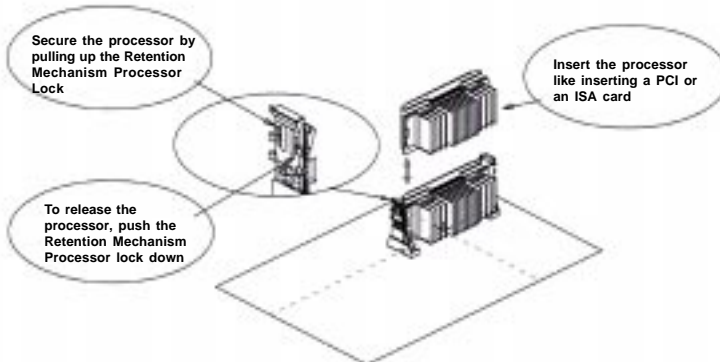

**Step 2:** Install the Processor.

Insert the Processor like inserting a PCI or an ISA card.

**Step 3:** Lock the Processor.

Lock the processor by pulling up the Retention Mechanism processor lock shown above.

**Note:** The Retention Mechanism processor lock can only lock S.E.C.C. 2 and S.E.P.P. processor.

### 2.1-2 CPU Core Speed Derivation Procedure

1. This mainboard can auto-detect the Core/Bus (Fraction) ratio of the CPU

<b>If</b>	<u>CPU Clock</u>	=	66MHz
	<u>Core/Bus ratio</u>	=	3.5
<b>then</b>	<u>CPU core speed</u>	=	<u>Host Clock</u> x <u>Core/Bus ratio</u>
		=	66MHz x 3.5
		=	233MHz

**Note:** CPU Vcore and Vi/o can be modified through CMOS.  
Vcore for CPU.  
Vi/o for Northbridge.

**2.1-3 Overclocking Jumper: SW2/SW3**

Overclocking is a process of operating a CPU/Processor beyond its specified frequency. SW2/SW3 is used for overclocking.

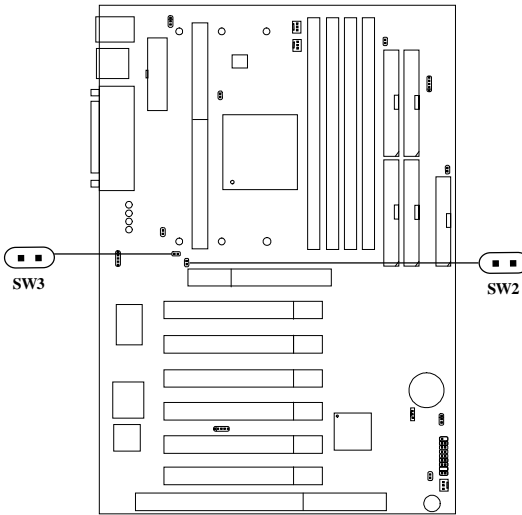

SW2	SW3	Feature
		Automatically detect 66MHz, 100MHz, 133MHz CPU Bus Frequency
		Virtually set CPU Bus Frequency into 100MHz
		Virtually set CPU Bus Frequency into 133MHz

**Note** If you used this jumper for overclocking, you also need to modify the CPU Bus ratio through CMOS.



### 2.1-4 Fan Power Connectors: CPUFAN/PSEFAN/SYSFAN

These connectors support system cooling fan with +12V. It supports three pin head connector. When connecting the wire to the connector, always take note that the red wire is the positive and should be connected to the +12V, the black wire is Ground and should be connected to GND. If your mainboard has System Hardware Monitor chipset on-board, you must use a specially designed fan with speed sensor to take advantage of this function.

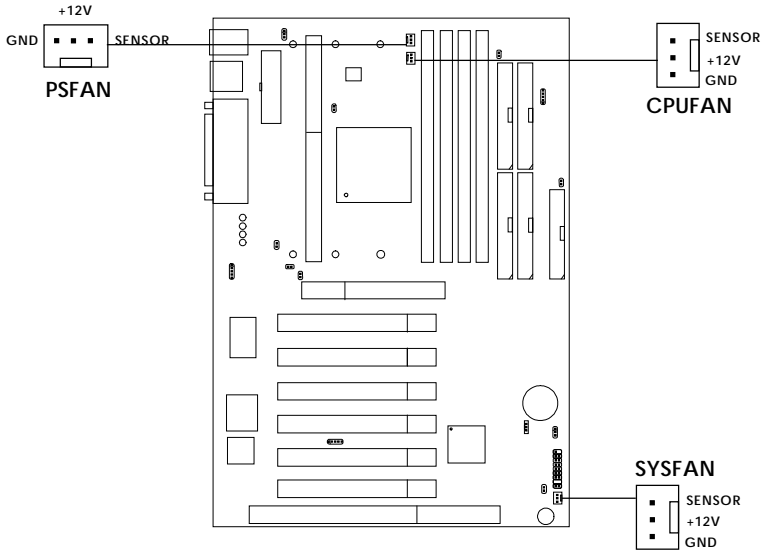

**PSFAN** : Power Supply Fan

**CPUFAN** : Processor Fan

**SYSFAN** : System(Chassis) Fan

For fans with fan speed sensor, every rotation of the fan will send out 2 pulses. System Hardware Monitor will count and report the fan rotation speed.

- Note:**
1. Always consult vendor for proper CPU cooling fan.
  2. CPU FAN supports the FAN control, you can install PC Alert utility, this will automatically set the CPU FAN Speed by CPU temperature.

## **2.2 Clear CMOS Jumper: JBAT1**

A battery must be used to retain the mainboard configuration in CMOS RAM. Short 1-2 pins of JBAT1 to store the CMOS data.

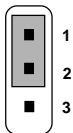
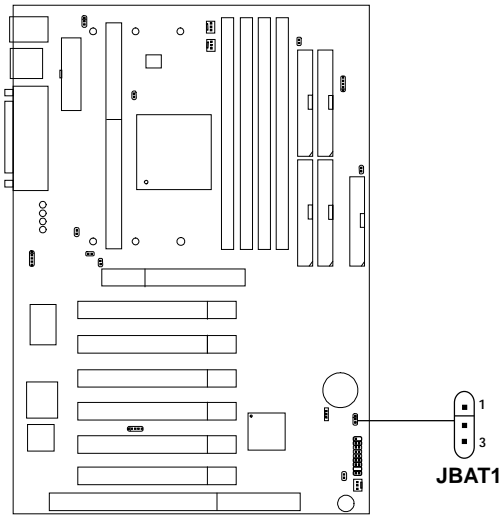

**Keep Data**

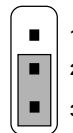

**Clear Data**

**Note:** You can clear CMOS by shorting 2-3 pin, while the system is off. Then, return to 1-2 pin position. Avoid clearing the CMOS while the system is on, it will damage the mainboard. Always unplug the power cord from the wall socket.

## 2.3 Memory Installation

### 2.3-1 Memory Bank Configuration

The mainboard supports a maximum memory size of 512MB (8M x 8) or 1G (16M x 4) registered DIMM for SDRAM: It provides four 168-pin **unbuffered** DIMMs (Double In-Line Memory Module) sockets. It supports 8 MB to 256 Mbytes DIMM memory module.

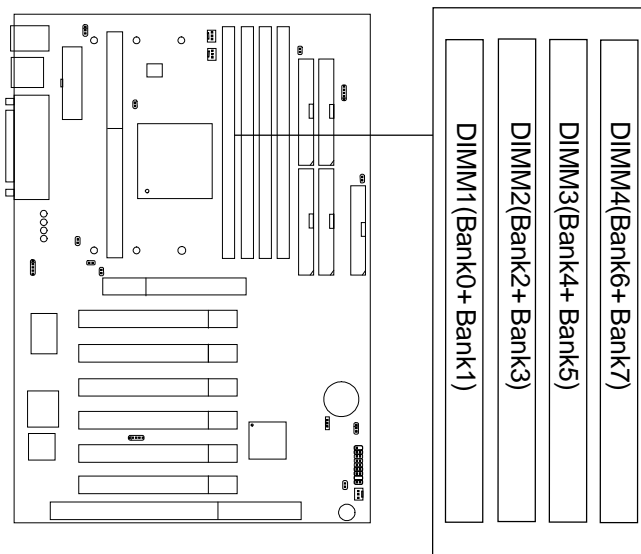

There are four kinds of DIMM specification supported by this mainboard: PC100 and PC66. If you use 66MHz CPU Bus Frequency, these four DIMM Specs. is supported. If you use 100 MHz CPU Bus Frequency, only PC100 DIMM Specs. is supported.

### 2.3-2 Memory Installation Procedures

#### A. How to install a DIMM Module

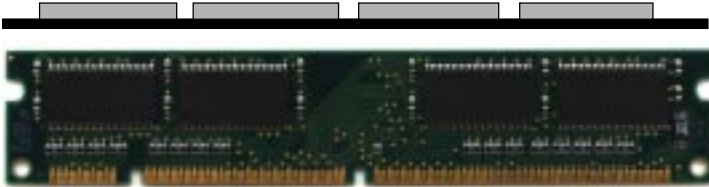

**Single Sided DIMM**

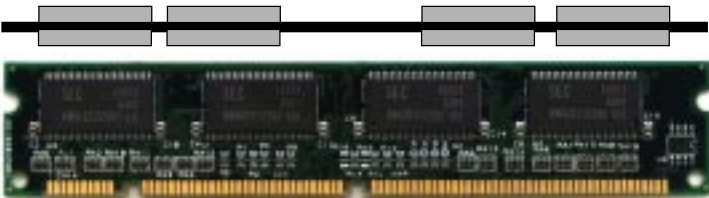

**Double Sided DIMM**

1. The DIMM slot has 2 Notch Keys “VOLT and DRAM”, so the DIMM memory module can only fit in one direction.
2. Insert the DIMM memory module vertically into the DIMM slot. Then push it in.

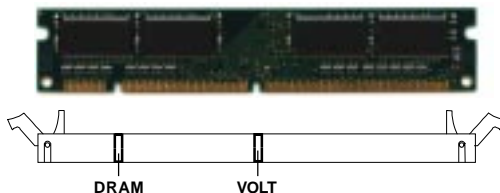

3. The plastic clip at the side of the DIMM slot will automatically close.

**2.3-3 Memory Population Rules**

1. Supports only SDRAM DIMM.
2. To operate properly, at least one 168-pin DIMM module must be installed.
3. This mainboard supports Table Free memory, so memory can be installed on DIMM1, DIMM 2, DIMM 3 or DIMM 4 in any order.
4. Supports 3.3 volt DIMM.
5. The DRAM addressing and the size supported by the mainboard is shown below:

**Table 2.3-1 SDRAM Memory Addressing**

DRAM Tech.	DRAM Density & Width	DRAM Addressing	Address Size		MB/DIMM	
			Row	Column	Single no. Side(S) pcs.	Double no. Side(D) pcs.
16M	1Mx16	ASYM	11	8	8MBx4	16MBx8
	2Mx8	ASYM	11	9	16MBx8	32MBx16
	4Mx4	ASYM	11	10	32MB	64MB
64M	2Mx32	ASYM	11	9	32MBx2	64MBx4
	2Mx32	ASYM	12	8	16MBx2	32MBx4
	4Mx16	ASYM	11	10	32MB	64MB
	4Mx16	ASYM	13	8	32MB	64MB
	8Mx8	ASYM	13	9	64MB	128MB
	16Mx4	ASYM	13	10	128MB	256MB
64M	2Mx32	ASYM	12	8	16MB	32MB
	4Mx16	ASYM	13	8	32MB	64MB
	8Mx8	ASYM	13	9	64MB	128MB
	16Mx4	ASYM	13	10	128MB	256MB

**2.4 Case Connector: JFP**

The Power Switch, Reset Switch, Power LED, Speaker, Keylock and HDD LED are all connected to the JFP connector block.

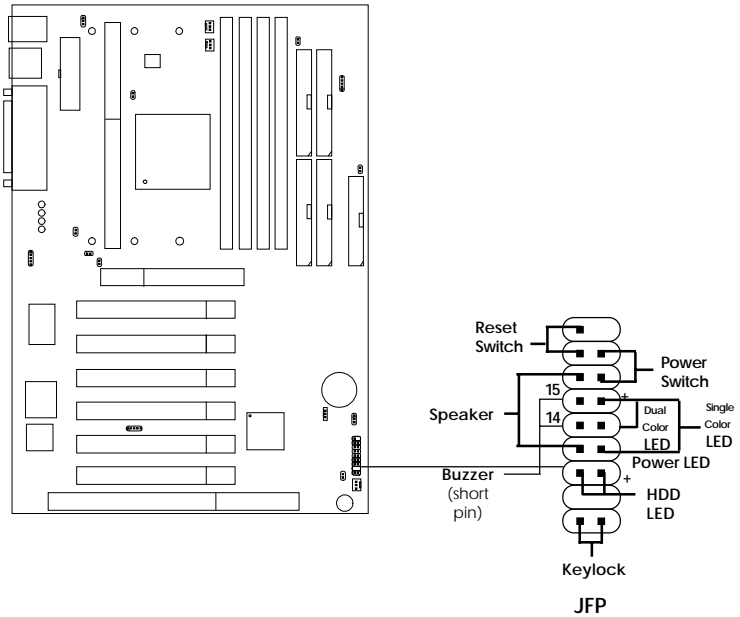

### **2.4-1 Power Switch**

Connect to a 2-pin push button switch. This switch has the same feature with JRMS1.

### **2.4-2 Reset Switch**

Reset switch is used to reboot the system rather than turning the power ON/OFF. Avoid rebooting while the HDD LED is lit. You can connect the Reset switch from the system case to this pin.

### **2.4-3 Power LED**

The Power LED is lit while the system power is on. Connect the Power LED from the system case to this pin. There are two types of LED that you can use: 3-pin single color LED or 2-pin dual color LED(ACPI request).

- a. 3 pin single color LED connect to pin 4, 5, & 6. This LED will lit when the system is on.
- b. 2 pin dual color LED connect to pin 5 & 6.

**GREEN**Color: Indicate the system is in full on mode.

**ORANGE**Color: Indicate the system is in suspend mode.

### **2.4-4 Speaker**

Speaker from the system case is connected to this pin.

If on-board Buzzer is available:

Short pin 14-15: On-board Buzzer Enabled.

Open pin 14-15: On-board Buzzer Disabled.

### **2.4-5 HDD LED**

HDD LED shows the activity of a hard disk drive. Avoid turning the power off while the HDD led is lit. You can connect the HDD LED from the system case to this pin.

### **2.4-6 Keylock**

Keylock allows you to disable the keyboard for security purposes. You can connect the keylock to this pin.

## **2.5 Floppy Disk Connector: FDD**

The mainboard also provides a standard floppy disk connector that supports 360K, 720K, 1.2M, 1.44M and 2.88M floppy disk types. This connector supports the provided floppy drive ribbon cables.

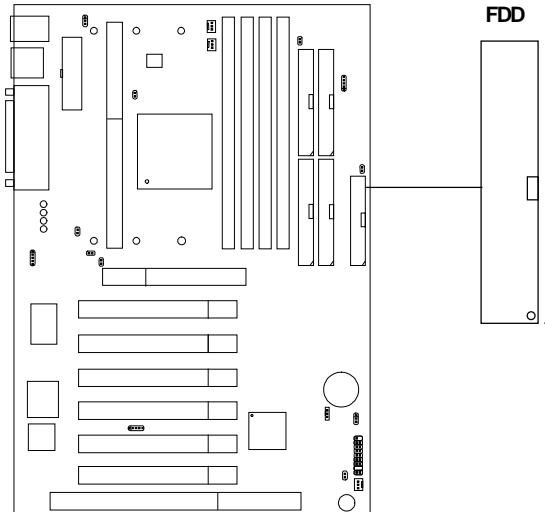



## **2.6 Hard Disk Connectors: IDE1, IDE2, IDE3 & IDE4**

The mainboard has a 32-bit Enhanced PCI IDE Controller that provides PIO mode 0~4, Bus Master, and Ultra DMA/33 function. It has four HDD connectors IDE1 (primary), IDE2 (secondary) IDE3 (third) and IDE4 (fourth). You can connect up to two hard disk drives, CD-ROM, 120MB Floppy (reserved for future BIOS) and other devices to IDE1, IDE2, IDE3 and IDE4. These connectors support the provided IDE hard disk cable.

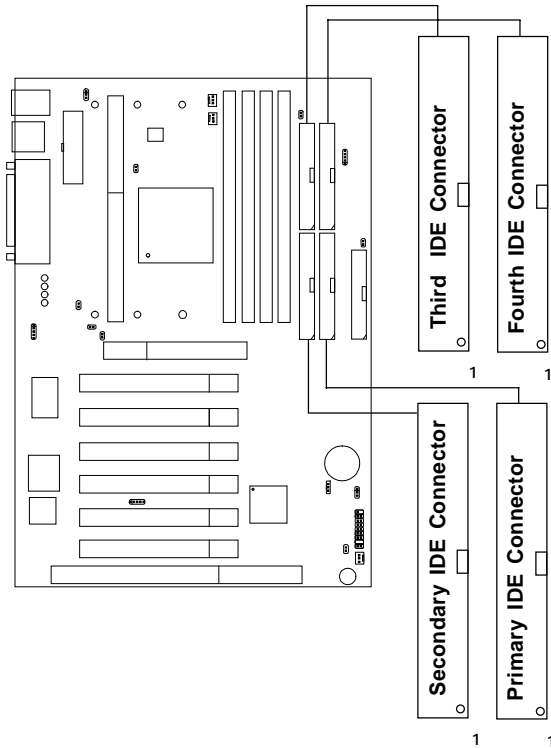

**IDE1**(Primary IDE Connector)

The first hard drive should always be connected to IDE1. IDE1 can connect a Master and a Slave drive. You must configure second hard drive to Slave mode by setting the jumper accordingly.

**IDE2**(Secondary IDE Connector)

IDE2 can also connect a Master and a Slave drive.

**IDE3**(Third IDE Connector)

IDE3 can also connect a Master and a Slave drive.

**IDE4**(Fourth IDE Connector)

IDE4 can also connect a Master and a Slave drive.

## **2.7 Power Supply**

### **2.7-1 ATX 20-pin Power Connector: JWR1**

This connector supports the power button on-board. Using the ATX power supply, functions such as Modem Ring Wake-Up and Soft Power Off are supported by this mainboard. This power connector supports instant power on function which means that system will boot up instantly when the power connector is inserted on the board.

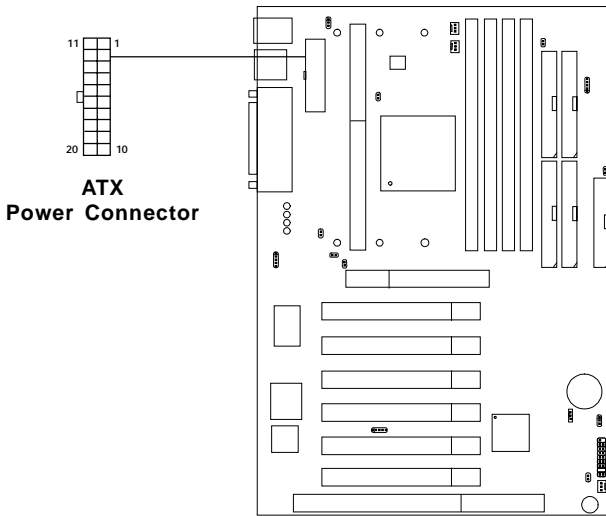

**PIN DEFINITION**

<b>PIN</b>	<b>SIGNAL</b>	<b>PIN</b>	<b>SIGNAL</b>
1	3.3V	11	3.3V
2	3.3V	12	-12V
3	GND	13	GND
4	5V	14	PS_ON
5	GND	15	GND
6	5V	16	GND
7	GND	17	GND
8	PW_OK	18	-5V
9	5V_SB	19	5V
10	12V	20	5V

**Warning:** Since the mainboard has the instant power on function, make sure that all components are installed properly before inserting the power connector to ensure that no damage will be done.

## **2.8 IrDA Infrared Module Connector: IR**

The mainboard provides one 5-pin infrared (IR) connector for IR modules. This connector is for optional wireless transmitting and receiving infrared module. You must configure the setting through the BIOS setup to use the IR function.

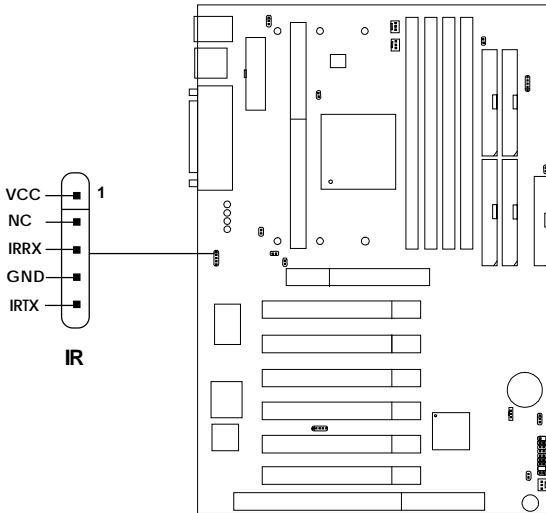

**2.9 Serial Port Connectors: COM A and COM B**

The mainboard has two 9-pin male DIN connectors for serial port COM A and COM B. These ports are 16550A high speed communication port that send/receive 16 bytes FIFOs. You can attach a mouse or a modem cable directly into this connector.

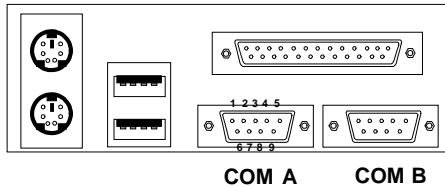

**Serial Port (9-pin Male)**

**PIN DEFINITION**

PIN	SIGNAL
1	<b>DCD</b> (Data Carry Detect)
2	<b>SIN</b> (Serial In or Receive Data)
3	<b>SOUT</b> (Serial Out or Transmit Data)
4	<b>DTR</b> (Data Terminal Ready)
5	<b>GND</b>
6	<b>DSR</b> (Data Set Ready)
7	<b>RTS</b> (Request To Send)
8	<b>CTS</b> (Clear To Send)
9	<b>RI</b> (Ring Indicate)

**2.10 Parallel Port Connector: LPT1**

The mainboard provides a 25 pin female centronic connector for LPT. A parallel port is a standard printer port that also supports Enhanced Parallel Port(EPP) and Extended capabilities Parallel Port(ECP). See connector and pin definition below:

**Parallel Port (25-pin Female)**

**LPT 1**

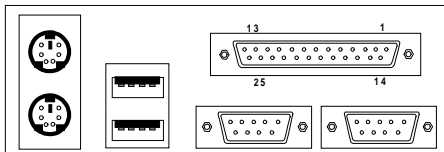

**PIN DEFINITION**

<b>PIN</b>	<b>SIGNAL</b>	<b>PIN</b>	<b>SIGNAL</b>
1	STROBE	14	AUTO FEED#
2	DATA0	15	ERR#
3	DATA1	16	INIT#
4	DATA2	17	SLIN#
5	DATA3	18	GND
6	DATA4	19	GND
7	DATA5	20	GND
8	DATA6	21	GND
9	DATA7	22	GND
10	ACK#	23	GND
11	BUSY	24	GND
12	PE	25	GND
13	SELECT		

**2.11 Mouse Connector: JKBMS1**

The mainboard provides a standard PS/2<sup>®</sup> mouse mini DIN connector for attaching a PS/2<sup>®</sup> mouse. You can plug a PS/2<sup>®</sup> mouse directly into this connector. The connector location and pin definition are shown below:

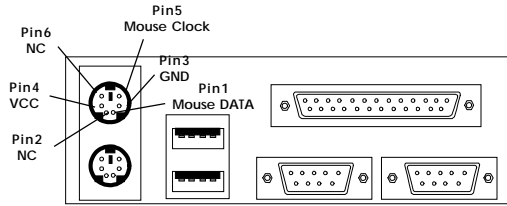

**PS/2 Mouse (6-pin Female)**

**2.12 Keyboard Connector: JKBMS1**

The mainboard provides a standard PS/2<sup>®</sup> keyboard mini DIN connector for attaching a keyboard. You can plug a keyboard cable directly to this connector.

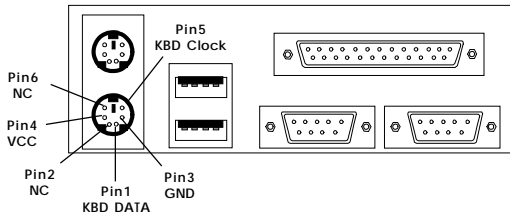

**PS/2 Keyboard (6-pin Female)**



### 2.13 USB Connectors

The mainboard provides a **UHCI(Universal Host Controller Interface) Universal Serial Bus root** for attaching USB devices like: keyboard, mouse and other USB devices. You can plug the USB device directly to this connector.

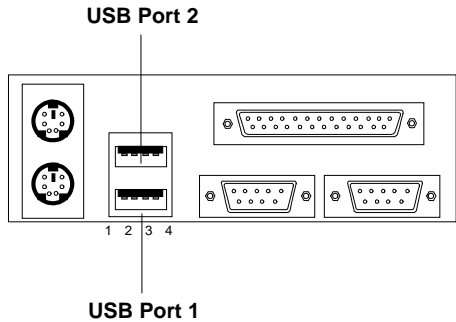

PIN	SIGNAL
1	VCC
2	-Data0
3	GND
4	+Data0

## 2.14 Power Saving Switch Connector: JGS1

Attach a power saving switch to **JGS1**. When the switch is pressed, the system immediately goes into suspend mode. Press any key and the system wakes up.

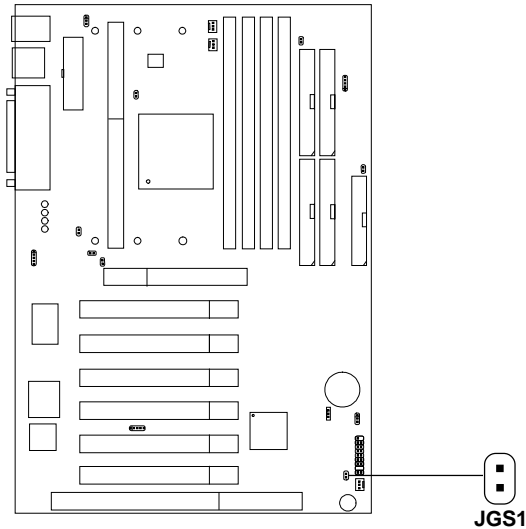

## 2.15 Wake-Up on LAN Connector: JWOL1

The JWOL connector is for use with LAN add-on cards that supports Wake Up on LAN function. To use this function, you need to set the “Wake-Up on LAN” to enable at the BIOS Power Management Setup.

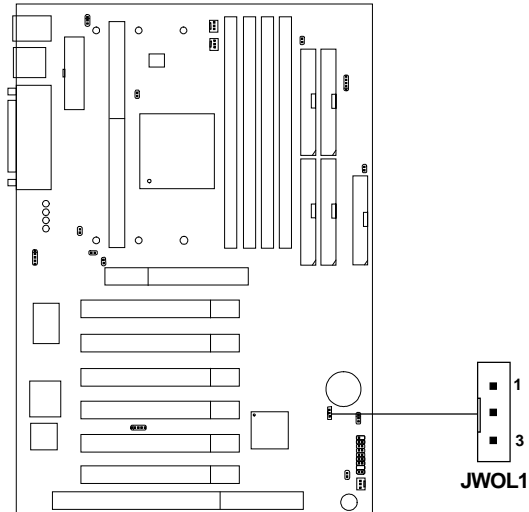

PIN	SIGNAL
1	5VSB
2	GND
3	MP_WAKEUP

**Note:** LAN wake-up signal is active “high”.

**Note:** To be able to use this function, you need a power supply that provide enough power for this feature.  
(Power supply with 750 ma 5V Stand-by)

## **2.16 Diagnostic LED**

The mainboard provides a Special Diagnostic LED for users to be aware of their mainboard conditions. The LED helps user determine the problem of the mainboard.

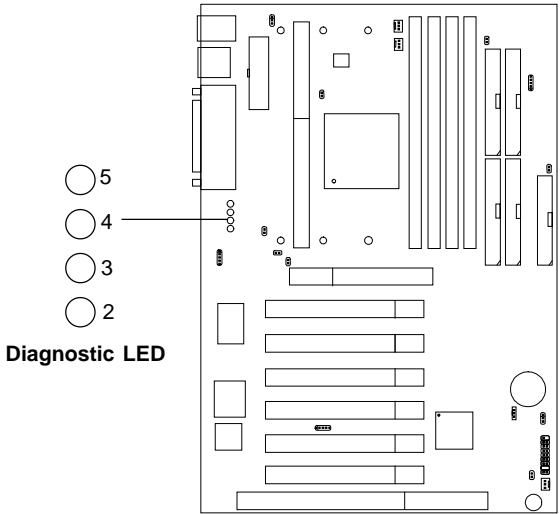

**Diagnostic LED Function**

<b>Diagnostic LED 5 4 3 2</b>	<b>Description</b>	<b>Possible Problem/ Solution</b>
0 0 0 0	System Power ON. This will start BIOS Initialization	System D-LED will hang here The Processor might be damage or not installed properly Damage/Discharge Lithium Battery
0 0 0 1	Early Chipset Initialization	***
0 0 1 0	Memory Detection Test Testing Onboard memory size	System D-LED will hang here The Memory module might be damage or not installed properly.
0 0 1 1	Decompressing BIOS image to RAM for fast booting.	***
0 1 0 0	Initializing Keyboard Controller	***
0 1 0 1	Testing VGA BIOS This will start writing VGA sign-on messages to the screen.	System D-LED will produce Beep sound The VGA card might be damage or not inserted properly.
0 1 1 0	Processor Initialization This will show information regarding the processor (like brand name, system bus, etc...)	***
0 1 1 1	Testing RTC (Real Time Clock)	Low Lithium Battery
1 0 0 0	Initializing Video Interface This will start detecting CPU clock, checking type of video onboard. Then, detect and initialize the video adapter	***
1 0 0 1	BIOS Sign On This will start showing information about Logo, processor brand name, etc.....	***
1 0 1 0	Testing Base and Extended Memory Testing base memory from 240K to 640K and extended memory above 1MB using various patterns.	***
1 0 1 1	Assign Resource to all ISA	***
1 1 0 0	Initializing Hard Drive Controller This will initialize IDE drive and controller	Check IDE cable for proper installation
1 1 0 1	Initializing Floppy Drive Controller This will initialize Floppy Drive and controller	System D-LED will hang here The Floppy Drive Cable might not be installed properly
1 1 1 0	Boot Attempt This will set low stack and boot via INT19h.	***
1 1 1 1	Operating System Booting.	***

**1 = GREEN 0 = RED**

**\*\*\* Check local Vendor for possible internal mainboard problem.**

## 2.17 CPU Temperature Sensor: JSOR1

This is used to check the CPU temperature. The JSOR1 is a sensor that is placed near the processor heatsink. This will monitor the CPU temperature.

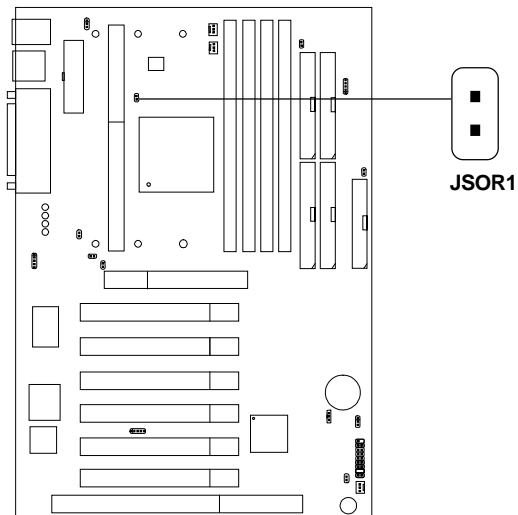

**2.18 Modem Wake Up Connector: JMDM1**

The JMDM1 connector is use for the Modem add-on card which supports the Modem Wake Up function. To use this function, you need to set the “Resume By Ring” to enable at the BIOS Power Management Setup.

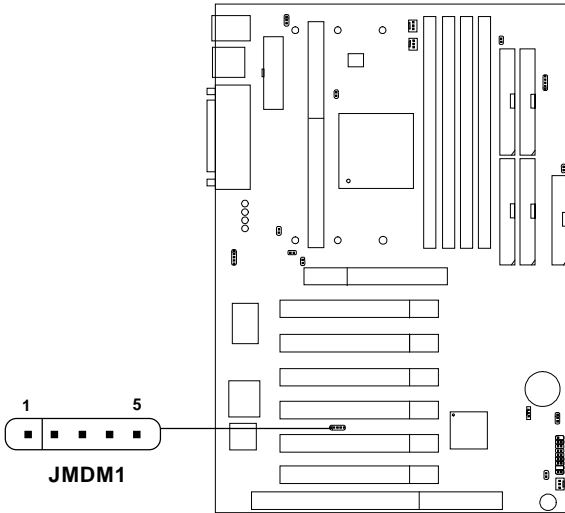

PIN	SIGNAL
1	NC
2	GND
3	MDM_WAKEUP
4	NC
5	5VSB

**Note:** Modem wake-up signal is active “low”.

**Note:** To be able to use this function, you need a power supply that provide enough power for this feature.  
(Power supply with 750 ma 5V Stand-by)

**2.19 TOP TECH. III: JT3 (Optional)**

This is used to check the AGP card or BX chipset temperature. The JT3 is a 2-pin connector which can be inserted with a 20cm length thermistor. It is located near the chipset heatsink that monitors the chipset temperature. The BIOS setup for “TOP TECH. III” should be set to enabled.

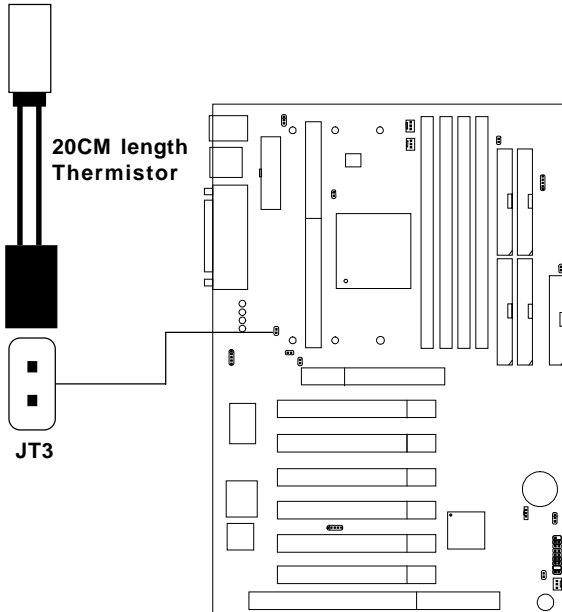



## **2.20 Chassis Intrusion Switch Case: JCASE**

This connector is connected to 2-pin connector chassis switch. If the Chassis is open, the switch will be short. The system will record this status. To clear the warning, you must enter the BIOS setting and clear the status.

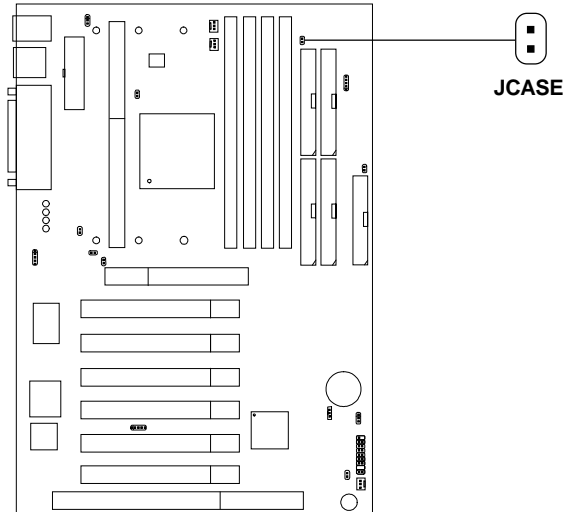

## 2.21 Ultra DMA 66 LED Connector: J3

This connector is used for Ultra DMA 66 IDE 3 & IDE 4 HDD LED status. The Ultra DMA 66 HDD LED shows the activity of the hard disk drive.

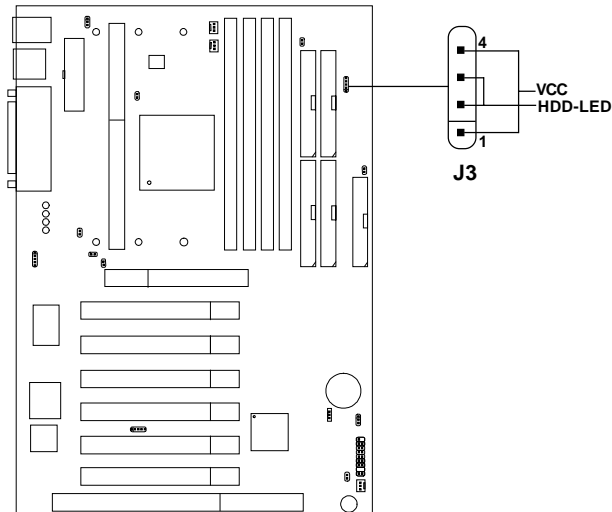

## 2.22 Keyboard Power: JKBV

The JKBV jumper is for setting keyboard power. This function should be set in the BIOS for the keyboard and PS/2 mouse Wake-up function.

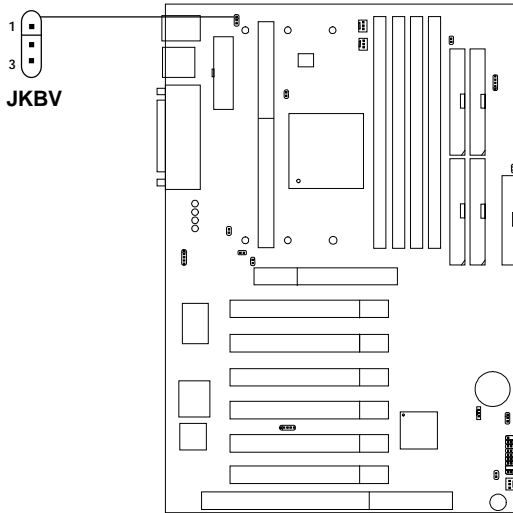

JKBV

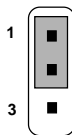

5V Standby  
Enable keyboard  
power on function

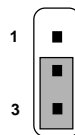

5V (default)  
Disable keyboard  
power on function

**Note:** To be able to use this function, you need a power supply that provide enough power for this feature.  
(Power supply with 750 ma 5V Stand-by)

### **2.23 PCI slots and ISA Slot**

There are 6 PCI slots and 1 ISA slot. All PCI slots can be used as master.

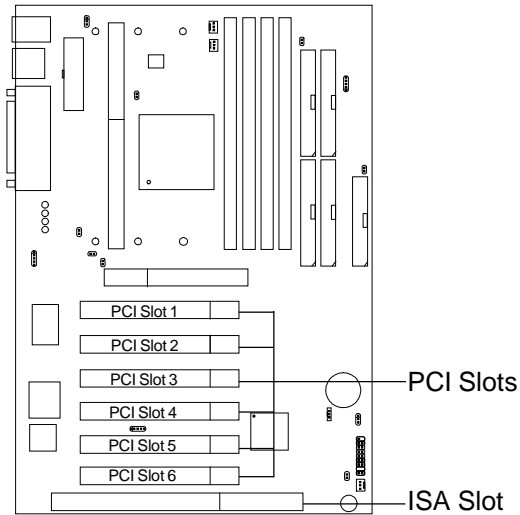

## **Chapter 3**

### **AWARD® BIOS SETUP**

Award® BIOS ROM has a built-in Setup program that allows users to modify the basic system configuration. This type of information is stored in battery-backed RAM (CMOS RAM), so that it retains the Setup information when the power is turned off.

## 3.1 Entering Setup

Power on the computer and press <Del> immediately to allow you to enter Setup. The other way to enter Setup is to power on the computer. When the below message appears briefly at the bottom of the screen during the POST (Power On Self Test), press <Del> key or simultaneously press <Ctrl>, <Alt>, and <Esc> keys.

TO ENTER SETUP BEFORE BOOT PRESS <CTRL-ALT-ESC>  
OR <DEL> KEY

If the message disappears before you respond and you still wish to enter Setup, restart the system to try again by turning it OFF then ON or pressing the “RESET” button on the system case. You may also restart by simultaneously pressing <Ctrl>, <Alt>, and <Delete> keys. If you do not press the keys at the correct time and the system does not boot, an error message will be displayed and you will again be asked to,

PRESS <F1> TO CONTINUE, <CTRL-ALT-ESC>  
OR <DEL> TO ENTER SETUP

## 3.2 Getting Help

### Main Menu

The on-line description of the highlighted setup function is displayed at the bottom of the screen.

### Status Page Setup Menu/Option Page Setup Menu

Press F1 to pop up a small help window that describes the appropriate keys to use and the possible selections for the highlighted item. To exit the Help Window press <F1> or <Esc>.

### 3.3 The Main Menu

Once you enter Award® BIOS CMOS Setup Utility, the Main Menu (Figure 1) will appear on the screen. The Main Menu allows you to select from eleven setup functions and two exit choices. Use arrow keys to select among the items and press <Enter> to accept or enter the sub-menu.

```

ROM PCI/ISA BIOS (2A59IM4C)
  CMOS SETUP UTILITY
  AWARD SOFTWARE, INC.

```

STANDARD CMOS SETUP	<<<CPU PLUG & PLAY III>>>
BIOS FEATURES SETUP	INTEGRATED PERIPHERALS
CHIPSET FEATURES SETUP	SUPERVISOR PASSWORD
POWER MANAGEMENT SETUP	USER PASSWORD
PNP/PCI CONFIGURATION	IDE HDD AUTO DETECTION
LOAD SETUP DEFAULTS	SAVE & EXIT SETUP
	EXIT WITHOUT SAVING
Esc : Quit	↑↓→← : Select Item
F10 : Save & Exit Setup	(Shift)F2 : Change Color
Time, Date, Hard Disk Type...	

#### Standard CMOS Setup

This setup page includes all the items in a standard compatible BIOS.

#### BIOS Features Setup

This setup page includes all the items of Award® special enhanced features.

**Chipset Features Setup**

This setup page includes all the items of chipset special features.

**Power Management Setup**

This category determines the power consumption for system after setting the specified items. Default value is Disable.

**PNP/PCI Configuration Setup**

This category specifies the IRQ level for PCI and ISA devices.

**Load Setup Defaults**

Chipset defaults indicates the values required by the system for the maximum performance.

**CPU Plug & Play III**

This function supports CPU Plug & Play III and Special Hardware Monitor.

**Integrated Peripherals**

Change, set or disable onboard I/O, IRQ, and DMA assignment.

**Supervisor Password/User Password**

Change, set or disable password. This function allows the user access to the system and setup or just setup.

**IDE HDD Auto Detection**

Automatically configure hard disk parameters.

**Save & Exit Setup**

Save CMOS value changes to CMOS and exit setup.

**Exit Without Saving**

Abandon all CMOS value changes and exit setup.



### 3.4 Standard CMOS Setup

The items in Standard CMOS Setup Menu are divided into 10 categories. Each category includes no, one or more than one setup items. Use the arrow keys to highlight the item and then use the <PgUp> or <PgDn> keys to select the value you want in each item.

ROM PCI/ISA BIOS (2A59IM4A)  
STANDARD CMOS SETUP  
AWARD SOFTWARE, INC.

Date(mm:dd:yy): Fri, Feb 28,1997							
Time(hh:mm:ss): 00:00:00							
HARD DISKS	TYPE	SIZE	CYLS	HEADS	PRECOMP	LANDZONE	SECTOR MODE
Primary Master:	Auto	0	0	0	0	0	AUTO
Primary Slave :	Auto	0	0	0	0	0	AUTO
Secondary Master :	Auto	0	0	0	0	0	AUTO
Secondary Slave :	Auto	0	0	0	0	0	AUTO
Drive A :	1.44M,3.5in.			Base Memory:		640K	
Drive B :	None			Extended Base Memory:		15360K	
Video :	EGA/VGA			Other Memory:		384K	
Halt On :	All, but Keyboard			Total Memory:		16384K	
ESC : Quit            ↑↓→← : Select Item        PU/PD/+- : Modify F1 : Help            (Shift)F2 : Change Color							

**Date**

The date format is <day><month> <date> <year>.

<b>Day</b>	Day of the week, from Sun to Sat, determined by BIOS. Read-only.
<b>month</b>	The month from Jan. through Dec.
<b>date</b>	The date from 1 to 31 can be keyed by numeric function keys.
<b>year</b>	The year, depends on the year of the BIOS

**Time**

The time format is <hour> <minute> <second>.

**PrimaryMaster/PrimarySlave  
SecondaryMaster/Secondary Slave**

These categories identify the types of 2 channels that have been installed in the computer. There are 45 pre-defined types and 4 user definable types for Enhanced IDE BIOS. Type 1 to Type 45 are pre-defined. Type User is user-definable.

Press PgUp/<+> or PgDn/<-> to select a numbered hard disk type or type the number and press <Enter>. Note that the specifications of your drive must match with the drive table. The hard disk will not work properly if you enter improper information for this category. If your hard disk drive type is not matched or listed, you can use Type User to define your own drive type manually.

If you select Type User, related information is asked to be entered to the following items. Enter the information directly from the keyboard and press <Enter>. This information should be provided in the documentation from your hard disk vendor or the system manufacturer.

If the controller of HDD interface is ESDI, the selection shall be  
“Type 1”.

If the controller of HDD interface is SCSI, the selection shall be  
“None”.

If the controller of HDD interface is CD-ROM, the selection shall be  
“None”.

<b>CYLS.</b>	number of cylinders
<b>HEADS</b>	number of heads
<b>PRECOMP</b>	write precom
<b>LANDZONE</b>	landing zone
<b>SECTORS</b>	number of sectors
<b>MODEHDD</b>	access mode

### 3.5 BIOS Features Setup

ROM PCI/ISA BIOS (2A59IM4A)  
 BIOS FEATURES SETUP  
 AWARD SOFTWARE, INC.

Anti-Virus Protection By : Disabled	Video BIOS Shadow : Enabled
CPU Internal Cache : Enabled	System BIOS Lock : Enabled
External Cache : Enabled	
CPU L2 Cache ECC Checking: Enabled	
Processor Number Feature : Enabled	
Quick Power on Self Test : Disabled	
Boot From LAN First : Disabled	
Boot Sequence : A,C,SCSI	
Swap Floppy Drive : Disabled	
Boot Up Floppy Seek : Enabled	
Floppy FIFO Control : Disabled	
Boot up NumLock status : On	
Gate A20 Option : Fast	
Security Option : Setup	
PCI/VGA palette snoop : Disabled	
OS select for DRAM>64MB : Non-OS2	
Report No FDD For WIN 95 : Yes	
	Esc : Quit    ↑↓→← : Select item
	F1 : Help      PU/PD/+/- : modify
	F5 : Old Value(Shift) F2 : Color
	F6 : Load BIOS Defaults
	F7 : Load Setup Defaults

#### Anti-Virus Protection

During and after the system boots up, any attempt to write to the boot sector or partition table of the hard disk drive will halt the system and the following error message will appear. For the meantime, you can run an anti-virus program to locate the problem.

**Disable**(default)

No warning message to appear when anything attempts to access the boot sector or hard disk partition table.

**Enable**

Activates automatically when the system boots up causing a warning message to appear when anything attempts to access the boot sector of hard disk partition table.

**CPU Internal Cache**

The default value is Enabled.

**Enabled** (default)    Enable cache

**Disabled**            Disable cache

**Note:** The internal cache is built in the processor.

**External Cache**

Choose Enabled or Disabled. This option enables the level 2 cache memory.

**CPU L2 Cache ECC Checking**

Choose Enabled or Disabled. This option enables the level 2 cache memory ECC(error check correction). Using 66MHz CPU BUS Pentium® II processor, set to Enabled or Disabled. Using 100MHz CPU BUS Pentium® II processor, always set to Enabled. For Celeron™ processor w/o Cache, always set to Disabled.

**Processor Number Feature**

This option is for Pentium III processor. During Enabled, this will check the CPU Serial number. Disabled this option if you don't want the system to know the Serial number.

**Quick Power On Self Test**

This category speeds up Power On Self Test (POST) after you power on the computer. If this is set to Enabled, BIOS will shorten or skip some check items during POST.

**Enabled**                Enable quick POST

**Disabled** (default)    Normal POST

**Boot From LAN First**

During Enabled, if there's a LAN card onboard, the priority from booting will be from the LAN.

**Boot Sequence**

This category determines which drive the computer searches first for the disk operating system (i.e., DOS). The settings are A,C,SCSI/C,A,SCSI/C,CD-ROM,A/CD-ROM,C,A/D,A,SCSI/E,A,SCSI/F,A,SCSI/SCSI,A,C/SCSI,C,A/C,LS/ZIP,C only. Default value is A,C,SCSI.

**Swap Floppy Drive**

Switches the floppy disk drives between being designated as A and B. Default is Disabled.

**Boot Up Floppy Seek**

During POST, BIOS will determine if the floppy disk drive installed is 40 or 80 tracks. 360K type is 40 tracks while 760K, 1.2M and 1.44M are all 80 tracks.

**Floppy FIFO Control**

During Enabled, the FDD disk will perform better.

**Boot Up NumLock Status**

The default value is On.

<b>On</b> (default)	Keypad is numeric keys.
<b>Off</b>	Keypad is arrow keys.

**Gate A20 Option**

<b>Normal</b>	The A20 signal is controlled by keyboard controller or chipset hardware.
<b>Fast</b> (default)	The A20 signal is controlled by port 92 or chipset specific method.

### Security Option

This category allows you to limit access to the system and Setup, or just to Setup.

<b>System</b>	The system will not boot and access to Setup will be denied if the correct password is not entered at the prompt.
<b>Setup(default)</b>	The system will boot, but access to Setup will be denied if the correct password is not entered at the prompt.

### PCI VGA Palette Snooping

Choose Disabled or Enabled. Some graphic controllers which are not VGA compatible, take the output from a VGA controller and map it to their display as a way to provide the boot information and the VGA compatibility.

However, the color information coming from the VGA controller is drawn from the palette table inside the VGA controller to generate the proper colors, and the graphic controller needs to know what is in the palette of the VGA controller. To do this, the non-VGA graphic controller watches for the Write access to the VGA palette and registers the snoop data. In PCI based systems, where the VGA controller is on the PCI bus and a non-VGA graphic controller is on an ISA bus, the Write Access to the palette will not show up on the ISA bus if the PCI VGA controller responds to the Writes.

In this case, the PCI VGA controller should not respond to the Write. It should only snoop the data and permit the access to be forwarded to the ISA bus. The non-VGA ISA graphic controller can then snoop the data on the ISA bus. Unless you have the above situation, you should disable this option.

<b>Disabled</b> (default)	Disables the function
<b>Enabled</b>	Enables the function

### OS Selection for DRAM > 64MB

Allows OS2® to be used with > 64 MB of DRAM. Settings are Non-OS/2 (default) and OS2. Set to OS/2 if using more than 64MB and running OS/2®.

**Report No FDD For WIN 95**

This function is only used when you are testing SCT for Windows® 95 Logo.

**Video BIOS Shadow**

Determines whether video BIOS will be copied to RAM for faster execution. Video shadow will increase the video performance.

**Enabled** (default)

Video shadow is enabled

**Disabled**

Video shadow is disabled

**System BIOS Lock**

This item allows the users to lock/unlock the system BIOS. During enabled, the user will not be able to overwrite or flash the system BIOS. The default setting is Enabled.



### 3.6 Chipset Features Setup

The Chipset Features Setup option is used to change the values of the chipset registers. These registers control most of the system options in the computer.

Choose the “CHIPSET FEATURES SETUP” from the Main Menu and the following screen will appear.

**ROM PCI/ISA BIOS(2A59IM4A)**  
**CMOS SETUP UTILITY**  
**CHIPSET FEATURES SETUP**

SDRAM Configuration by :Manual	Auto Detect DIMM/PCI Clk :Enabled
SDRAM RAS to CAS Delay :3	Spread Spectrum Modulated:Enabled
SDRAM RAS Precharge Time :3	
SDRAM CAS Latency Time :3	
DRAM Data Integrity Mode :Non-ECC	
System BIOS Cacheable :Disabled	
Video BIOS Cacheable :Disabled	
Video RAM Cacheable :Disabled	
8 Bit I/O Recovery Time :1	
16 Bit I/O Recovery Time :1	
Memory Hole at 15M-16M :Disabled	
Passive Release :Enabled	
Delayed Transaction :Disabled	
AGP Aperture Size (MB) :64	
	Esc : Quit    ↑↓→← : Select item
	F1 : Help      PU/PD/+/- : modify
	F5 : Old Value(Shift) F2 : Color
	F6 : Load BIOS Defaults
	F7 : Load Setup Defaults

**Note:** Change these settings only if you are familiar with the chipset.

### **SDRAM Configuration by**

Choose SPD, the SDRAM time will load from the DIMM EEPROM value. Choose manual, the value will be set by SDRAM Ras-to-CAS Delay and SDRAM CAS Latency Time. The settings are SPD and Manual.

If the DIMM is without EEPROM, then set this item to Manual. Set SDRAM Ras-to-CAS Delay and SDRAM CAS Latency Time to 3.

### **SDRAM RAS to CAS Delay**

You can select the SDRAM RAS to CAS delay time in HCLKs of 2 or 3 (default). This should be set depending on the SDRAM installed.

### **SDRAM RAS Precharge Time**

You can select the SDRAM RAS Precharge time in HCLKs of 2 or 3 (default). This should be set depending on the SDRAM installed.

### **SDRAM CAS Latency Time**

You can select CAS latency time in HCLKs of 2 or 3 (default). This should be set depending on the SDRAM installed.

### **DRAM Data Integrity Mode**

Select Non-ECC or ECC(error-correcting code), according to the type of installed DRAM. The settings are Non-ECC (default) or ECC.

### **System BIOS Cacheable**

Select Enabled allows caching of the system BIOS ROM at F000h-FFFFFh, resulting in better system performance. However, if any program writes to this memory area, a system error may result.

<b>Enabled</b>	BIOS access cached
<b>Disabled</b>	BIOS access not cached

### **Video BIOS Cacheable**

Select Enabled allows caching of the system BIOS ROM at C0000h-F7FFFh, resulting in better video performance. However, if any program writes to this memory area, a system error may result.

<b>Enabled</b>	Video BIOS access cached
<b>Disabled</b>	Video BIOS access not cached

### **Video RAM Cacheable**

Select Enabled allows caching of the video RAM, resulting in better system performance. However, if any program writes to this memory area, a system error may result.

### **8 Bit I/O Recovery Time**

The recovery time is the length of time, measured in CPU clocks, which the system will delay after the completion of an input/output request. This delay takes place because the CPU is operating so much faster than the input/output bus that the CPU must be delayed to allow for the completion of the I/O.

This item allows you to determine the recovery time allowed for 8 bit I/O. Choices are from NA, 1 to 8 CPU clocks.

### **16 Bit I/O Recovery Time**

This item allows you to determine the recovery time allowed for 16 bit I/O. Choices are from NA, 1 to 4 CPU clocks.

### **Memory Hole At 15M-16M**

In order to improve performance, certain space in memory can be reserved for ISA cards. This memory must be mapped into the memory space below 16 MB.

Enabled	Memory hole supported.
Disabled	Memory hole not supported.

### **Passive Release**

When Enabled, CPU to PCI bus accesses are allowed during passive release. Otherwise, the arbiter only accepts another PCI master access to local DRAM. The settings are Enabled or Disabled.

---

**Delayed Transaction**

The chipset has an embedded 32-bit posted write buffer to support delay transactions cycles. Select Enabled to support compliance with PCI specification version 2.1. The settings are Enabled or Disabled.

**AGP Aperture Size (MB)**

Select the size of the Accelerated Graphics Port (AGP) aperture. The aperture is a portion of the PCI memory address range dedicated for graphics memory address space. Host cycles that hit the aperture range are forwarded to the AGP without any translation.

**Auto Detect DIMM/PCI Clk**

This item allows you to select the DIMM/PCI clock. The other sockets will not generate when DIMM/PCI cards are not installed. The setting should be set to enabled which works better for EMI.

**Spread Spectrum Modulated**

This item allows you to select the clock generator Spread Spectrum function. The default is enabled. This item should always be set to Disabled, if you over-clock the processor.

### 3.7 Power Management Setup

The Power Management Setup will appear on your screen like this:

```

ROM PCI/ISA BIOS (2A59IM4A)
POWER MANAGEMENT SETUP
AWARD SOFTWARE, INC.
    
```

ACPI Suspend Type	:S1 (POS)	Power status LED	:Single Color
Power Management	:User Define	Wake Up on LAN	:Enabled
PM Control by APM	:Yes	IRQ 8 Break Suspend	:Disabled
Video Off Method	:DPMS		
Video Off After	:Standby	** Reload Global Timer Events **	
Modem Use IRQ	:3	IRQ [3-7,9-15],NMI	: Disabled
Reserve IRQ9	:Yes	Primary IDE 0	: Enabled
Doze Mode	:Disable	Primary IDE 1	: Enabled
Standby Mode	:Disable	Secondary IDE 0	: Disabled
Suspend Mode	:Disable	Secondary IDE 1	: Disabled
HDD Power Down	:Disable	Floppy Disk	: Disabled
HDD Down When Suspend	:Enabled	Serial Port	: Enabled
Throttle Duty Cycle	:62.5%	Parallel Port	: Disabled
VGA Active Monitor	:Disabled		
Soft-Off by PWR-BTNN	:Instant-Off		
CPUFAN off in Suspend	:Enabled		
Resume by Ring	:Disabled		
Resume by Alarm	:Disabled		
Date(of Month) Alarm	:2	Esc : Quit	↑↓→← : Select item
Time(hh:mm:ss) Alarm	: 0:0:0	F1 : Help	PU/PD/+/- : modify
		F5 : Old Value(Shift)	F2 : Color
		F6 : Load BIOS Defaults	
		F7 : Load Setup Defaults	
Restore AC/Power Loss	:Off		

#### ACPI Suspend Type

This options sets the ACPI Power Management standby state.

- S1** Power\_on suspend
- S3** STR (Suspend to DRAM)

**Note:** Power supply of 5VSB must support 1 A.

#### Power Management

This category determines the power consumption for system after selecting below items. Default value is user define. The following pages tell you the options of each item & describe the meanings of each options.

**Power Management**

<b>Disable</b>	Global Power Management will be disabled.
<b>User Define</b>	Users can configure their own power management.
<b>Min Saving</b>	Pre-defined timer values are used such that all timers are in their MAX value.
<b>Max Saving</b>	Pre-defined timer values are used such that all timers are in their MIN value.

**PM Control by APM**

<b>No</b>	System BIOS will ignore APM when power managing the system.
<b>Yes</b>	System BIOS will wait for APM's prompt before it enter any PM mode

**Note :**Enable this for O.S. with APM like Windows® 95, Windows® NT, etc.

**Video Off Method**

<b>Blank Screen</b>	The system BIOS will only blank off the screen when disabling video.
<b>V/H SYNC C+Blank</b>	In addition to (1), BIOS will also turn off the V-SYNC & H-SYNC signals from VGA card to monitor.
<b>DPMS</b>	This function is enabled only for VGA card supporting DPMS.

**Note:** Green monitors detect the V/H SYNC signals to turn off its electron gun.

### Video Off After

The settings are N/A, Standby, Doze, or Suspend. This option is for choosing the setting in which the monitor will turn off.

<b>N/A</b>	Always turn on.
<b>Doze</b>	During Doze mode, the monitor will be turned off.
<b>Standby</b>	During Standby mode, the monitor will be turned off.
<b>Suspend</b>	During Suspend mode, the monitor will be turned off.

The default setting is Standby.

### MODEM Use IRQ

Name the interrupt request (IRQ) line assigned to the modem (if any) on your system. Activity of the selected IRQ always awakens the system. The settings are NA, 3, 4, 5, 7, 9, 10, or 11.

### Reserve IRQ 9

This item is reserved for Windows® 98 ACPI mode. Choose yes, if you use Windows® 98 ACPI mode. Otherwise, set to no.

### Doze Mode

<b>Disable</b>	System will never enter DOZE mode.
<b>1 Min/2 Min/</b>	Defines the continuous idle time before the system enters DOZE mode. If any item defined in the options of “Power Down and Resume events” is enabled & active, DOZE timer will be reloaded. When the system have entered Doze mode, any of the items enabled in “Wake Up Events in Doze and Standby” will trigger the system to wake up.
<b>4 Min/6 Min/</b>	
<b>8 Min/10 Min/</b>	
<b>20 Min/30 Min/</b>	
<b>40 Min/1 Hr</b>	

**Standby Mode****Disable**

System will never enter STANDBY mode.

**1 Min/2 Min/**

Defines the continuous idle time before the system enters STANDBY mode.

**4 Min/6 Min/****8 Min/10 Min/****20 Min/30 Min/****40 Min/1 Hr**

If any item defined in the options of “Power Down and Resume events” is enabled & active, STANDBY timer will be reloaded. When the system has entered Standby mode, any of the items that are enabled in “Wake Up Events of Doze and Standby” will trigger the system to wake up.

**Suspend Mode****Disable**

System will never enter SUSPEND mode.

**1 Min/2 Min/**

Defines the continuous idle time before the system enters SUSPEND mode.

**4 Min/6 Min/****8 Min/10 Min/****20 Min/30 Min/****40 Min/1 Hr**

If any item defined in the options of “Power Down & Resume Events” is enabled & active, SUSPEND timer will be reloaded. When the system has entered SUSPEND mode, any of the items enabled in the “Power Down & Resume Events” will trigger the system to wake up.

**HDD Power Down****Disable**

HDD’s motor will not shut off.

**1 Min/2 Min/**

Defines the continuous HDD idle time before the HDD enters the power saving mode (motor off). BIOS will turn off the HDD’s motor when time is out.

**3 Min/4 Min/****5 Min/6 Min/****7 Min/8 Min/****9 Min/10 Min/****11 Min/12 Min/****13 Min/14 Min/****15 Min**



**HDD Down When Suspend**

During Enabled, the hard disk power will be automatically shut down, if the system goes into suspend mode.

**Throttle Duty Cycle**

This option will determine how much power will be used by the CPU , if the system goes into suspend mode.

**VGA Active Monitor**

During Enabled, if there's no activity in the monitor screen, the system will go into Power Saving Mode. During Disabled, the system will go into Power Saving Mode, whether there is activity in the monitor screen or not. The settings are Disabled and Enabled.

**Soft-Off by PWR-BTTN**

The settings are Delay 4 sec or Instant-off. During Delay 4 sec, if you push the switch once, the system goes into suspend mode. If you push it more than 4 seconds, the system will be turned off. During instant-off, the system will turn off once you push the switch.

**CPUFAN Off in Suspend**

During Enabled, if the system goes into suspend mode, the CPU fan will stop. During Disabled, if the system goes into suspend mode, the CPU fan will resume.

**Resume by Ring**

During Disabled, the system will ignore any incoming call from the modem. During Enabled, the system will boot up if there's an incoming call from the modem.

**Note:** If you have change the setting, you must let the system boot up until it goes to the operating system, before this function will work.

### **Resume by Alarm**

This function is for setting date and time for your computer to boot up. During Disabled, you cannot use this function. During Enabled, choose the Date and Time Alarm:

**Date(of month) Alarm** You can choose which month the system will boot up. Set to 0, to boot every month.

**Time(hh:mm:ss) Alarm** You can choose what hour, minute and second the system will boot up.

**Note:** If you have change the setting, you must let the system boot up until it goes to the operating system, before this function will work.

### **Restore AC/Power Loss**

The settings are power ON/OFF or Last Status. During power ON, after every AC/Power Loss, the system will be turned on. During last status, after every AC/Power Loss, whatever the system status, it will be the same when the AC power returns. During Off, after every AC/Power Loss, the system will be shutdown.

### **Power LED**

This item determines which state the Power LED will use. The settings are Blink, Dual color, and Single color. During blink, the power LED will blink when the system enters the suspend mode. When the mode is in Dual Color, the power LED will change its color. Choose the single color and the power LED will always remain lit.

### **Wake Up On LAN**

To use this function, you need a LAN add-on card which support power on functions. It should also support the wake-up on LAN jumper (JWOL1).

**Enabled** Wake up on LAN supported.

**Disabled** Wake up on LAN not supported.

**IRQ 8 Clock Event**

You can Enable or Disable monitoring of IRQ 8 so it does not awaken the system from suspend mode.

**Reload Global Timer Events**

<b>IRQ[3-7,9-15], NMI</b>	<b>: Enabled</b>
<b>Primary IDE 0</b>	<b>: Enabled</b>
<b>Primary IDE 1</b>	<b>: Disabled</b>
<b>Secondary IDE 0</b>	<b>: Disabled</b>
<b>Secondary IDE 1</b>	<b>: Disabled</b>
<b>Floppy Disk</b>	<b>: Enabled</b>
<b>Serial Port</b>	<b>: Enabled</b>
<b>Parallel Port</b>	<b>: Enabled</b>

During Enabled, if any interrupt event occurs, the system will wake-up from suspend mode. During Disabled, the system will not monitor any interrupt event.

### 3.8 PNP/PCI Configuration Setup

You can manually configure the PCI Device's IRQ. The following pages tell you the options of each item & describe the meanings of each options.

**ROM PCI/ISA BIOS (2A69HM4D)**  
**PNP/PCI CONFIGURATION SETUP**  
**AWARD SOFTWARE, INC.**

PnP OS Installed	:No	Assign IRQ for VGA	: Enabled
Resources Controlled By	:Manual	Assign IRQ for USB	: Enabled
Reset Configuration Data	:Disabled	Used MEM base addr	: N/A
IRQ-3 assigned to	:Legacy ISA		
IRQ-4 assigned to	:Legacy ISA		
IRQ-5 assigned to	:PCI/ISA PnP		
IRQ-7 assigned to	:PCI/ISA PnP		
IRQ-9 assigned to	:PCI/ISA PnP		
IRQ-10 assigned to	:PCI/ISA PnP		
IRQ-11 assigned to	:PCI/ISA PnP		
IRQ-12 assigned to	:PCI/ISA PnP		
IRQ-14 assigned to	:PCI/ISA PnP		
IRQ-15 assigned to	:PCI/ISA PnP		
DMA-0 assigned to	:PCI/ISA PnP		
DMA-1 assigned to	:PCI/ISA PnP		
DMA-3 assigned to	:PCI/ISA PnP		
DMA-5 assigned to	:PCI/ISA PnP		
DMA-6 assigned to	:PCI/ISA PnP		
DMA-7 assigned to	:PCI/ISA PnP		
		Esc : Quit    ↑↓→← : Select item	
		F1 : Help        PU/PD/+/- : modify	
		F5 : Old Value(Shift) F2 : Color	
		F6 : Load BIOS Defaults	
		F7 : Load Setup Defaults	

#### PnP OS Installed

When set to YES, BIOS will only initialize the PnP cards used for booting (VGA, IDE, SCSI). The rest of the cards will be initialized by the PnP operating system like Windows® 95 or 98. When set to NO, BIOS will initialize all the PnP cards. So, for non-PnP operating system (DOS, Netware®), this option must set to NO.

### **Resources Controlled By**

By Choosing “Auto”, the system BIOS will detect the system resource and automatically assign the relative IRQ and DMA Channel for each peripheral.

By Choosing “Manual”(default), the user will need to assign IRQ & DMA for add-on cards. Be sure that there is no conflict for IRQ/DMA and I/O ports.

**Note:** When choosing “Auto”, you must be sure that all of the system add-on cards are PnP type.

### **Reset Configuration Data**

The system BIOS supports the PnP feature so the system needs to record which resource is assigned and protect resources from conflict. Every peripheral device has a node which is called ESCD. This node records which resources are assigned to it. The system needs to record and update ESCD to the memory locations. These locations (4K) are reserved at the system BIOS.

If Disabled (default) is chosen, the system’s ESCD will update only when the new configuration varies from the last one.

If Enabled is chosen, the system will be forced to update the system’s ESCD. Then, this option will be auto-set to Disable.

IRQ-3	assigned to	: Legacy	ISA
IRQ-4	assigned to	: Legacy	ISA
IRQ-5	assigned to	: PCI/ISA	PnP
IRQ-7	assigned to	: Legacy	ISA
IRQ-9	assigned to	: PCI/ISA	PnP
IRQ-10	assigned to	: PCI/ISA	PnP
IRQ-11	assigned to	: PCI/ISA	PnP
IRQ-12	assigned to	: PCI/ISA	PnP
IRQ-14	assigned to	: PCI/ISA	PnP

IRQ-15 assigned to : PCI/ISA PnP  
DMA-0 assigned to : PCI/ISA PnP  
DMA-1 assigned to : PCI/ISA PnP  
DMA-3 assigned to : PCI/ISA PnP  
DMA-5 assigned to : PCI/ISA PnP  
DMA-6 assigned to : PCI/ISA PnP  
DMA-7 assigned to : PCI/ISA PnP

The above settings will be shown on the screen only if “Manual” is chosen for the *Resources Controlled By* function.

Legacy is the term which signifies that a resource is assigned to the ISA Bus and provides for non PnP ISA add-on card. PCI/ISA PnP signifies that a resource is assigned to the PCI Bus or provides for ISA PnP add-on cards and peripherals.

### **Assign IRQ for VGA**

Lets the user choose which IRQ to assign for VGA card.

### **Assign IRQ for USB**

Set to Enabled when USB port will be used. Set to Disable if the USB port will not be used.

### **Used MEM base addr**

Lets the user choose the Legacy ISA addr. The settings are NA#, C800, CC00, D000, D400, D800 or DC00.

### **Used MEM base addr**

Lets the user choose the Legacy ISA addr. memory length. The settings are 8K, 16K, 32K, or 64K.

### **3.9 Load BIOS/Setup Defaults**

This Main Menu item loads the default system values. If the CMOS is corrupted, the defaults are loaded automatically. Choose this item and the following message appears:

“ Load Setup Defaults (Y / N) ? N “

To use the Setup defaults, change the prompt to “Y” and press < Enter >

**Note:** The Setup defaults can be customized to increase performance. However the BIOS defaults can always be used as a back up if there is some problem with the mainboard operation.

### 3.10 CPU Plug & Play III

This Special Features Setup is used by System Hardware Monitor chipset. You can manually change the value of each option.

ROM PCI/ISA BIOS (2A69HM4C)  
 INTEGRATED PERIPHERALS  
 AWARD SOFTWARE, INC.

<pre> *****CPU PLUG &amp; PLAY III***** Adjust CPU Voltage :2.00V CPU Speed          :Manual CPU Ratio          : x3 CPU Frequency     : 100/33MHz(Off) On/Off means Spread Spectrum (↑)  ***** POST SHOWING ***** Chassis Fan Detected      :Disabled Power Fan Detected       :Disabled CPU Fan Detected         :Enabled Chassis Intrusion Detect  :Disabled Voltage Detected        :Enabled Vcore Voltage Detected   :Enabled +2.5V Voltage Detected   :Enabled +3.3V Voltage Detected   :Enabled +5.0V Voltage Detected   :Enabled + 12V Voltage Detected   :Enabled - 12V Voltage Detected   :Enabled -5.0V Voltage Detected   :Enabled VBat Voltage Detected    :Enabled 5VSB Voltage Detected    :Enabled                 </pre>	<pre> ***** SYSTEM MONITOR ***** Chassis FAN RPM          :5000 System Temperature      :40°C/104°F CPU Temperature         :35°C/93°F TOP TECH. II           :Disabled CPU Critical Temp       :Disabled Shutdown Temp          :Disabled  *****Chipset Feature***** Chipset Voltage Adjust  :3.3V  Esc : Quit      ↑↓→← : Select item F1  : Help PU/PD/+/- : modify F5  : Old Value(Shift) F2 : Color F6  : Load BIOS Defaults F7  : Load Setup Defaults                 </pre>
---	---

#### Adjust CPU Voltage

This function is used to adjust the CPU voltage. During overclocking, the processor might get unstable. Try adjusting the CPU voltage to lessen the heat generated by the CPU voltage.

**NOTE:** We do not guarantee that Motherboard or other components will work properly after overclocking.



### CPU Speed

Check your processor and set this function accordingly. If you set this to Manual, you can set the CPU Ratio and CPU Frequency accordingly. CPU Frequencies are: 66, 68, 75, 83 and 100, 103, 112, 117, 124, 129, 133, 138, 143, 148, 153. **Though 68, 75, 83, 103, 112, 117, 124, 129, 133, 138, 143, 148 and 153 frequencies are available, it is advised that you use these only for testing since this is not stable as the CPU is not designed for these frequencies.** CPU ratio are: 3, 3.5, 4, 4.5, 5, 5.5, 6, 6.5, 7, 7.5, or 8.

Note: If you set the CPU Ratio and CPU Frequency to be too high, and the system will not turn on, then restart the system. Press “F10” until bootup. This will set the default setting.

### **Chassis Fan Detected/Power Fan Detected/CPU Fan +1.5V Detected/Voltage Detected/Vcore Voltage Detected/+2.5V Voltage Detected/+3.3V Voltage Detected/+5.0 Voltage Detected/+12V Voltage Detected/-12V Voltage Detected/-5.0 Voltage Detected/VBat Voltage Detected/5VSB Voltage Detected**

During Enabled, this will show the CPU/FAN voltage chart during system boot up. During Disabled, this will not show.

### Chassis Intrusion Detect

Set this option to Enabled, Reset, or Disabled the chassis intrusion detector. During Enabled, any intrusion on the system chassis will be recorded. The next time you turn on the system, it will show a warning message. To be able to clear those warning, choose Reset. After clearing the message it will go back to Enabled.

**Chassis/Power/CPU Fan RPM**

During Enabled, this will monitor the RPM of your CPU/Chassis/Power fan.

**System Temperature/CPU Temperature**

This will show the System and CPU temperature.

**TOP TECH. II**

This option is used to disabled or enabled the JT3 connector 20 cm thermistor. The default setting is Disabled (See page 2-45). When choose Enabled, "TOP TECH II Temp" item will appear onscreen.

**CPU Critical Temp**

This option is for setting the critical temperature level for the processor. When the processor reach the temperature you set, this will reduce the load on the processor.

**Shutdown Temp**

This option is for setting the Shutdown temperature level for the processor. When the processor reach the temperature you set, this will shutdown the system. This function only works with Windows® 95 operating system.

**Chipset Voltage Adjust**

This option is used to set the northbridge chipset. The settings are 3.3v/3.4v/3.5v/3.6v. The default setting is 3.3v.

### 3.11 Integrated Peripherals

ROM PCI/ISA BIOS (2A69HM4D)  
 INTEGRATED PERIPHERALS  
 AWARD SOFTWARE, INC.

IDE HDD Block Mode	: Enabled	UART Mode Select	: Normal
IDE Primary Master PIO	: Auto	Onboard Parallel Mode	: 378/IRQ7
IDE Primary Slave PIO	: Auto	Parallel Port Mode	: SPP
IDE Secondary Master PIO	: Auto		
IDE Secondary Slave PIO	: Auto		
IDE Primary Master UDMA	: Auto		
IDE Primary Slave UDMA	: Auto		
IDE Secondary Master UDMA	: Auto		
IDE Secondary Slave UDMA	: Auto		
On-Chip Primary PCI IDE	: Enabled		
On-Chip Primary PCI IDE	: Enabled		
USB Keyboard support	: Disabled		
Init Display First	: PCI slot		
Onboard Sound	: Enable		
Power On Function	: Button	Esc : Quit	↑↓→← : Select item
Onboard FDC controller	: Enabled	F1 : Help	PU/PD/+/- : modify
Onboard Serial Port 1	: 3F8/IRQ4	F5 : Old Value(Shift)	F2 : Color
Onboard Serial Port 2	: 2F8/IRQ3	F6 : Load BIOS Defaults	
		F7 : Load Setup Defaults	

#### IDE HDD Block Mode

**Enabled/Disabled** Enabled allows the Block mode access for the IDEHDD.

#### IDE Primary Master PIO

**Auto/Mode0/Mode1-4**

#### IDE Primary Slave PIO

**Auto/Mode0/Mode1-4**

#### IDE Secondary Master PIO

**Auto/Mode0/Mode1-4**

**IDE Secondary Slave PIO****Auto/Mode0/Mode1-4**

For these 4 IDE options, choose “Auto” to have the system BIOS auto detect the IDE HDD operation mode for PIO access.

**Note:** Some IDE HDD cannot operate at the responding HDD’s mode. When the user has selected “Auto” and the system BIOS has accepted the HDD response mode, the user may degrade the HDD’s operation mode. Ex: IF the HDD reported that it can operate in mode 4 but it is not operating properly, the user will have to manually change the operation mode to mode 3.

Choosing Mode 1-4 will have the system ignore the HDD’s reported operation mode and use the selected mode instead.

**Note:** According to ATA specs. Mode 4 transfer rate is > Mode 3 > Mode 2 > Mode 1 > Mode 0. If the user’s HDD can operate at Mode 3 the user can also select a slower Mode (i.e. Mode 0-2) but not a faster Mode (ie Mode 4).

**On-Chip Primary PCI IDE****Enabled/Disabled****On-Chip Secondary PCI IDE****Enabled/Disabled**

The system provides for an On-Board On-Chipset PCI IDE controller that supports Dual Channel IDE (Primary and Secondary). A maximum of 4 IDE devices can be supported. If the user install the Off-Board PCI IDE controller (i.e. add-on cards), the user must choose which channels will be disabled. This will depend on which channel will be used for the Off-Board PCI IDE add-on card.

**USB Keyboard Support****Enabled/Disabled**

Choosing Enabled will allow the system to use USB keyboard without a device driver.

**Init Display First****PCISlot**

If both PCI VGA card and AGP card are installed, the system will display the PCI VGA card first.

**AGP**

If both PCI VGA card and AGP card are installed, the system will show the AGP card first.

**Onboard Sound****Enabled/Disabled**

Enabled or Disabled the onboard sound chip.

**Power ON Function**

This function allows you to select Button only, Keyboard 98 Password, Mouse Left or Mouse Right, and Hot Key (Ctrl F1 to Ctrl F12) which features the same function to Power ON the system.

**Note:** If you choose Mouse Left or Mouse Right, you must let the system boot up until it goes to the BIOS table configuration, before this function will work. During Power OFF, double click the left or right mouse button to Power ON the system.

**Onboard FDC Controller****Enabled/Disabled**

The system has an on-board Super I/O chip with a FDD controller that supports 2 FDDs for 360K/720K/1.2M/1.44M/2.8M. Choose “Enabled” to use the on-board FDD controller for accessing the FDD. Otherwise choose “Disabled” to use the off-board FDD controller.

**Onboard Serial Port 1**

**Disabled/(3F8/IRQ4)/(2F8/IRQ3)/(3E8/IRQ4)/(2E8/IRQ3)**

**Onboard Serial Port 2**

**Disabled/(3F8/IRQ4)/(2F8/IRQ3)/(3E8/IRQ4)/(2E8/IRQ3)**

The system has an On-board Super I/O chipset with 2 serial ports. The On-board serial ports can be selected as:

**Disabled**

3F8/IRQ4	COM 1 uses IRQ4
2F8/IRQ3	COM 2 uses IRQ3
3E8/IRQ4	COM 3 uses IRQ4
2E8/IRQ3	COM 4 uses IRQ3

**Note:** Because the ISA Bus Interrupt accepts low to high edge trigger, the interrupt request line cannot be shared by multiple sources. If an off-board ISA add-on card with a serial port is installed the user may have to disable the on-board serial port because it will conflict with IRQ request line for the off-board serial port.

**UART Mode Select**

This item allows you to determine which InfraRed (IR) function of the onboard I/O chip, this function uses.

278H/IRQ5	Line Printer port 2
378H/IRQ5	Line Printer port 1

### Onboard Parallel Port

#### Disabled

(3BCH/IRQ7)/

(278H/IRQ5)/

(378H/IRQ5)

There is a built-in parallel port on the on-board Super I/O chipset that provides Standard, ECP, and EPP features. It has the following options:

#### Disable

3BCH/IRQ7

Line Printer port 0

278H/IRQ5

Line Printer port 2

378H/IRQ5

Line Printer port 1

### Onboard Parallel Mode

SPP : Standard Parallel Port

EPP : Enhanced Parallel Port

ECP : Extended Capability Port

**SPP/(EPP/SPP)/  
ECP(ECP/EPP)**

To operate the onboard parallel port as Standard Parallel Port only, choose "SPP." To operate the onboard parallel port in the ECP and SPP modes simultaneously, choose "ECP/SPP." By choosing "ECP", the onboard parallel port will operate in ECP mode only. Choosing "ECP/EPP" will allow the onboard parallel port to support both the ECP and EPP modes simultaneously. The ECP mode has to use the DMA channel, so choose the onboard parallel port with the ECP feature. After selecting it, the following message will appear: "ECP Mode Use DMA" At this time, the user can choose between DMA channels 3 or 1. The onboard parallel port is EPP Spec. compliant, so after the user chooses the onboard parallel port with the EPP function, the following

message will be displayed on the screen: “EPP Mode Select.” At this time either EPP 1.7 spec. or EPP 1.9 spec. can be chosen.



## 3.12 Supervisor/User Password Setting

This Main Menu item lets you configure the system so that a password is required each time the system boots or an attempt is made to enter the Setup program. Supervisor Password allows you to change all CMOS settings but the User Password setting doesn't have this function. The way to set up the passwords for both Supervisor and User are as follow:

1. Choose "Change Password" in the Main Menu and press <Enter>. The following message appears:

"Enter Password:"

2. The first time you run this option, enter your password up to 8 characters only and press <Enter>. The screen will not display the entered characters. For no password, just press <Enter>.
3. After you enter the password, the following message appears prompting you to confirm the password:

"Confirm Password:"

4. Enter exactly the same password you just typed in to confirm the password and press <Enter>.
  5. Move the cursor to Save & Exit Setup to save the password.
  6. If you need to delete the password you entered before, choose the Supervisor Password and press <Enter>. It will delete the password that you had before.
  7. Move the cursor to Save & Exit Setup to save the option you did. Otherwise, the old password will still be there when you turn on your machine next time.
-

### 3.13 IDE HDD Auto Detection

You can use this utility to automatically detect the characteristics of most hard drives.

When you enter this utility, the screen asks you to select a specific hard disk for Primary Master. If you accept a hard disk detected by the BIOS, you can enter “Y” to confirm and then press <Enter> to check next hard disk. This function allows you to check four hard disks and you may press the <Esc> after the <Enter> to skip this function and go back to the Main Menu.

**ROM ISA BIOS  
CMOS SETUP UTILITY  
AWARD SOFTWARE, INC.**

HARD DISKS	TYPE	SIZE	CYLS	HEADS	PRECOMP	LANDZONE	SECTOR MODE
Primary Master:	Auto	0	0	0	0	0	AUTO
Primary Slave :	Auto	0	0	0	0	0	AUTO
Secondary Master :	Auto	0	0	0	0	0	AUTO
Secondary Slave :	Auto	0	0	0	0	0	AUTO

Select Primary Master				Option (N=Skip) : N			
OPTIONS	SIZE	CYLS	HEAD	PRECOMP	LANDZ	SECTOR MODE	
2	2112	1023	64	0	4094	63	LBA
1	2113	4095	16	65535	4094	63	NORMAL
3	2113	2047	32	65535	4094	63	LARGE

[ESC: Skip]

## Chapter 4

### CREATIVE® AUDIO DRIVER (Optional)

#### 1. Overview

The Creative® ES1373 digital controller provides the next generation of audio performance to the PC market.

##### 1.1 Features

- SoundScape WaveTable Synthesizer.
- Full DOS Game Compatibility.
- PCI Bus Master for fast DMA.
- Fully Compliant with PC97 Power Management Specification.

##### 1.2 System Requirements

This section describes system requirements for the Audio Driver installation and Usage.

<b>Computer</b>	Intel® Pentium® II/Celeron™ processor or higher
<b>Operating system</b>	DOS 5.0 or higher, Windows® 95/98, Windows® NT 3.51 or 4.0, or OS/2®
<b>CD-ROM</b>	Double Speed or Higher
<b>Chipset</b>	Creative® ES1373

## **2. Audio Driver Setup & Usage Procedures**

Insert the CD-title into your CD-ROM drive. This CD will auto-run. This will display installation for VGA driver and sound driver. Also included are Intel® PIIX4 patch for Windows® 95/98, Trend PC-cillin 98, and Bus Master driver. Just click the button for automatic installation for audio driver.

### **2.1 Windows® 95/98**

If you start Windows® 95/98, this will automatically detect this hardware onboard “PCI Multimedia Audio Device” and “Gameport Joystick”. You need to click “Next”, then “Finish”. Do not click on the “Cancel”. The driver need these ID.

#### **2.1-1 Audio Driver Installation Procedure:**

- Step 1:** Insert the provided CD\_ROM disk into the CD-ROM drive.
- Step 2:** Look for the CD\_ROM drive, double click on the CD\_ROM icon. This will show the setup screen.
- Step 3:** Click on “Creative AudioPCI” sound drivers icon.
- Step 4:** This will copy the audio drivers into the hard drive.
- Step 5:** A message will appear stating you must restart the Windows® 95/98 system, select **yes** to restart.

## **2.2 Windows® NT 4.0**

### **2.2-1 Audio Driver Installation Procedure:**

- Step 1:** Click **Start** menu and select **Control Panel** from **Settings** group.
- Step 2:** Select **Multimedia** icon.
- Step 3:** Click on the **Devices** tab.
- Step 4:** Click **Add**.
- Step 5:** Double click on **Unlisted or Updated Driver** in the list.
- Step 6:** Insert the **CD-ROM Disk** into the CD-ROM Drive.
- Step 7:** When the Install from Disk dialog box appears, look for your CD-ROM drive :**\Sound\ Creative\AudioPCI\Drivers \NT40\English\I386\CD**
- Step 8:** Click **OK**.
- Step 9:** Click **OK**.
- Step 10:** A message will appear stating that the drivers were successfully installed. Click **OK**. You must now restart Windows® NT 4.0.

## **2.3 Detailed User's Manual**

The detailed user's manual can be found on following path of the CD-ROM provided:

**PATH: Sound\Creative\AudioPCI\Docs\Manual.doc**