

SUPER  [®]

X7SBL-LN1/LN2

USER'S MANUAL

Revision 1.1a

The information in this User's Manual has been carefully reviewed and is believed to be accurate. The vendor assumes no responsibility for any inaccuracies that may be contained in this document, makes no commitment to update or to keep current the information in this manual, or to notify any person or organization of the updates. **Please Note: For the most up-to-date version of this manual, please see our web site at www.supermicro.com.**

Super Micro Computer, Inc. ("Supermicro") reserves the right to make changes to the product described in this manual at any time and without notice. This product, including software, if any, and documentation may not, in whole or in part, be copied, photocopied, reproduced, translated or reduced to any medium or machine without prior written consent.

IN NO EVENT WILL SUPERMICRO BE LIABLE FOR DIRECT, INDIRECT, SPECIAL, INCIDENTAL, SPECULATIVE OR CONSEQUENTIAL DAMAGES ARISING FROM THE USE OR INABILITY TO USE THIS PRODUCT OR DOCUMENTATION, EVEN IF ADVISED OF THE POSSIBILITY OF SUCH DAMAGES. IN PARTICULAR, SUPERMICRO SHALL NOT HAVE LIABILITY FOR ANY HARDWARE, SOFTWARE, OR DATA STORED OR USED WITH THE PRODUCT, INCLUDING THE COSTS OF REPAIRING, REPLACING, INTEGRATING, INSTALLING OR RECOVERING SUCH HARDWARE, SOFTWARE, OR DATA.

Any disputes arising between manufacturer and customer shall be governed by the laws of Santa Clara County in the State of California, USA. The State of California, County of Santa Clara shall be the exclusive venue for the resolution of any such disputes. Supermicro's total liability for all claims will not exceed the price paid for the hardware product.

FCC Statement: This equipment has been tested and found to comply with the limits for a Class B digital device pursuant to Part 15 of the FCC Rules. These limits are designed to provide reasonable protection against harmful interference in a residential installation. This equipment generates, uses, and can radiate radio frequency energy and, if not installed and used in accordance with the manufacturer's instruction manual, may cause interference with radio communications. However, there is no guarantee that interference will not occur in a particular installation. If this equipment does cause harmful interference to radio or television reception, which can be determined by turning the equipment off and on, you are encouraged to try to correct the interference by one or more of the following measures:

*Reorient or relocate the receiving antenna.

*Increase the separation between the equipment and the receiver.

*Connect the equipment into an outlet on a circuit different from that to which the receiver is connected.

*Consult the dealer or an experienced radio/television technician for help.

California Best Management Practices Regulations for Perchlorate Materials: This Perchlorate warning applies only to products containing CR (Manganese Dioxide) Lithium coin cells. "Perchlorate Material-special handling may apply. See www.dtsc.ca.gov/hazardouswaste/perchlorate"

WARNING: Handling of lead solder materials used in this product may expose you to lead, a chemical known to the State of California to cause birth defects and other reproductive harm.

Manual Revision 1.1a

Release Date: January 22, 2010

Unless you request and receive written permission from Super Micro Computer, Inc., you may not copy any part of this document.

Information in this document is subject to change without notice. Other products and companies referred to herein are trademarks or registered trademarks of their respective companies or mark holders.

Copyright © 2010 by Super Micro Computer, Inc.

All rights reserved.

Printed in the United States of America

Preface

About This Manual

This manual is written for system integrators, PC technician and knowledgeable PC users. It provides information for the installation and use of the **SUPER** X7SBL-LN1/LN2 motherboard. The X7SBL-LN1/LN2 supports single Xeon[®] 3000 sequence processor with a system bus speed of 1330 MHz/1066 MHz. The Intel Xeon 3000 sequence processor supports the 775-Land Grid Array Package that interfaces with the motherboard via an LGA775 socket. With support of Dual-Core and Quad Core Technology, Wide Dynamic Execution, FSB, Dynamic Bus Inversion (DBI), Advanced Digital Media Boost, Smart Memory Access, and Thermal Management 2 (TM2), the X7SBL-LN1/LN2 delivers unparalleled system performance and great power efficiency in a slim package. Please refer to the motherboard specifications pages on our web site (<http://www.supermicro.com/Products/>) for updates on supported processors. This product is intended to be professionally installed and serviced by a technician.

Manual Organization

Chapter 1 describes the features, specifications and performance of the motherboard and provides detailed information about the chipset.

Chapter 2 provides hardware installation instructions. Read this chapter when installing the processor, memory modules and other hardware components into the system. If you encounter any problems, see **Chapter 3**, which describes troubleshooting procedures for video, memory and system setup stored in the CMOS.

Chapter 4 includes an introduction to the BIOS and provides detailed information on running the CMOS Setup utility.

Appendix A provides BIOS Error Beep Codes.

Appendix B lists the Windows OS Installation Instructions.

Appendix C lists Other Software Program Installation Instructions.

Conventions Used in the Manual

Special attention should be given to the following symbols for proper installation and to prevent damage done to the components or injury to yourself:



Warning: Important information given to ensure proper system installation, to prevent bodily injury or damage to the components.



Note: Additional Information given to differentiate various models or to ensure correct system setup.

Table of Contents

Chapter 1 Introduction

1-1	Overview	1-1
	Checklist.....	1-1
	Contacting Supermicro.....	1-2
SUPER	X7SBL-LN1/LN2 Image	1-3
SUPER	X7SBL-LN1/LN2 Layout	1-4
SUPER	X7SBL-LN1/LN2 Quick Reference	1-5
	Motherboard Features	1-6
	Chipset/System Block Diagram.....	1-8
1-2	Chipset Overview	1-9
1-3	Special Features	1-10
1-4	PC Health Monitoring.....	1-10
1-5	ACPI Features.....	1-11
1-6	Super I/O.....	1-12

Chapter 2 Installation

2-1	Static-Sensitive Devices.....	2-1
	Precautions	2-1
	Unpacking	2-1
2-2	Motherboard Installation.....	2-1
2-3	Processor and Heatsink Installation.....	2-2
2-4	Installing DIMMs.....	2-7
2-5	Control Panel Connectors/IO Ports.....	2-9
	1. Back Panel Connectors/IO Ports	2-9
	2. Front Control Panel.....	2-10
	3. Front Control Panel Pin Definitions	2-11
	NMI Button	2-11
	PWR LED	2-11
	HDD LED.....	2-12
	NIC1/NIC2 LED Indicators	2-12
	OH/Fan Fail LED.....	2-13
	Power Fail LED	2-13
	Reset Button.....	2-14
	PWR Button.....	2-14
2-6	Connecting Cables.....	2-15
	ATX Power Connector.....	2-15

	Processor Power Connector	2-15
	Universal Serial Bus	2-16
	Chassis Intrusion	2-16
	ATX PS/2 Keyboard and Mouse Ports	2-17
	Serial Ports	2-17
	Power LED	2-18
	External Speaker/Internal Buzzer	2-18
	GLAN (Ethernet Ports)	2-19
	VGA Connector	2-19
	Fan Headers	2-20
	Wake-On-Ring	2-21
	Wake-On-LAN	2-21
	Power Fault	2-22
	Power SMB Connector	2-22
2-7	Jumper Settings	2-23
	Explanation of Jumpers	2-23
	GLAN Enable/Disable	2-23
	Clear CMOS	2-24
	Watch Dog Enable/Disable	2-24
	PCI/PCI-E Slots to SMB Speeds	2-25
	VGA Enable/Disable	2-25
	Force-Power-On Enable/Disable	2-26
	USB Wake-Up	2-27
2-8	Onboard Indicators	2-28
	GLAN LEDs	2-28
	Onboard Power LED (LE1)	2-29
2-9	Floppy and SIM 1U IPMI Connections	2-30
	Floppy Connector	2-30
	SIM 1U IPMI	2-31

Chapter 3 Troubleshooting

3-1	Troubleshooting Procedures	3-1
	Before Power On	3-1
	No Power	3-1
	No Video	3-2
	Memory Errors	3-2
	Losing the System's Setup Configuration	3-2
3-2	Technical Support Procedures	3-3

3-3 Frequently Asked Questions 3-4
3-4 Returning Merchandise for Service..... 3-5

Chapter 4 BIOS

4-1 Introduction..... 4-1
4-2 Running Setup 4-2
4-3 Main BIOS Setup 4-2
4-4 Advanced Setup..... 4-7
4-5 Security Settings 4-23
4-6 Boot Settings..... 4-25
4-7 Exit 4-26

Appendices:

Appendix A BIOS POST Beep Codes.....A-1
Appendix B Installing the Windows OSB-1
Appendix C Installing Other Software Programs and Drivers.....C-1

Chapter 1

Introduction

1-1 Overview

Checklist

Congratulations on purchasing your computer motherboard from an acknowledged leader in the industry. Supermicro boards are designed with the utmost attention to detail to provide you with the highest standards in quality and performance.

Please check that the following items have all been included with your motherboard. If anything listed here is damaged or missing, contact your retailer.

All the following items are included in the retail box only:

One (1) Supermicro Mainboard

One (1) floppy drive ribbon cable (CBL-0022L)

Six (6) SATA cables (CBL-044L)

One (1) Supermicro CD containing drivers and utilities

One (1) User's/BIOS Manual

One (1) I/O shield

for X7SBL-LN1(CSE-PT02L)

for X7SBL-LN2(CSE-PT7L)

Contacting Supermicro

Headquarters

Address: Super Micro Computer, Inc.
980 Rock Ave.
San Jose, CA 95131 U.S.A.

Tel: +1 (408) 503-8000

Fax: +1 (408) 503-8008

Email: marketing@supermicro.com (General Information)
support@supermicro.com (Technical Support)

Web Site: www.supermicro.com

Europe

Address: Super Micro Computer B.V.
Het Sterrenbeeld 28, 5215 ML
's-Hertogenbosch, The Netherlands

Tel: +31 (0) 73-6400390

Fax: +31 (0) 73-6416525

Email: sales@supermicro.nl (General Information)
support@supermicro.nl (Technical Support)
rma@supermicro.nl (Customer Support)

Asia-Pacific

Address: Super Micro Computer, Inc
4F, No. 232-1, Liancheng Rd.
Chung-Ho 235, Taipei County
Taiwan, R.O.C.

Tel: +886-(2) 8226-3990

Fax: +886-(2) 8226-3991

Web Site: www.supermicro.com.tw

Technical Support:

Email: support@supermicro.com.tw

Tel: 886-2-8228-1366, ext.132 or 139

SUPER X7SBL-LN1/LN2 Image

Note: All pictures and drawings shown in this manual were based upon the latest PCB Revision available at the time of publishing of the manual. The motherboard you have received may or may not look exactly the same as those in this manual.

Motherboard Layout

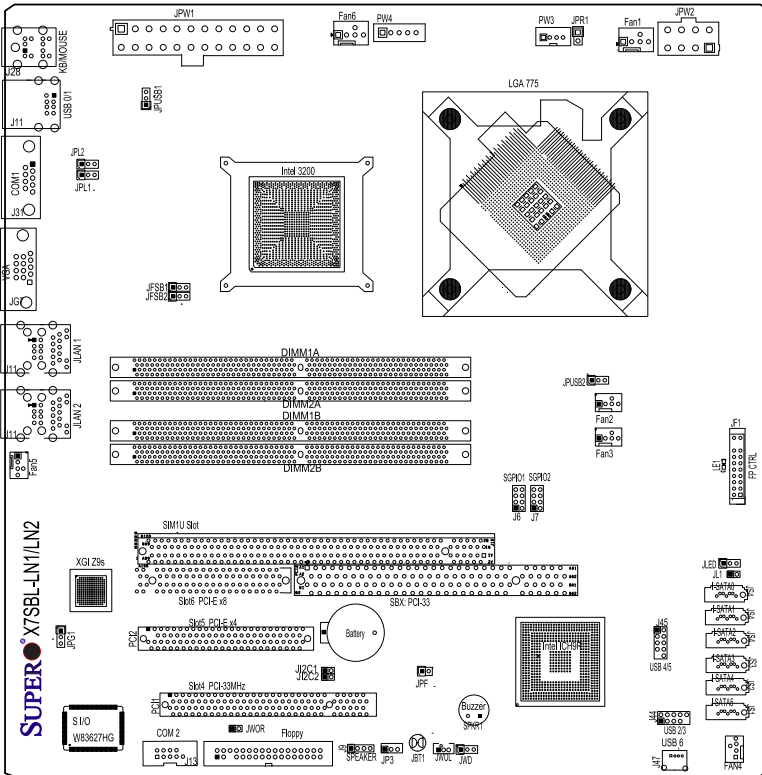

Important Notes to the User

- Jumpers not indicated are for testing only.
- See Chapter 2 for detailed information on jumpers, I/O ports and JF1 front panel connections.
- "•" indicates the location of "Pin 1."
- GLAN2 is only available on LN2 models.
- Slot 6 is specially designed for Supermicro riser cards only.

SUPER[®] X7SBL-LN1/LN2 Quick Reference

<u>Jumpers</u>	<u>Description</u>	<u>Default Setting</u>
J1 ² C1/JC ² C2	SMB to PCI Slots	Open/Open (Disabled)
JPF	Power Force On	Pins 1-2 (Reset)
JPG1	VGA Enable	Pins 1-2 (Enabled)
JPL1/JPL2	Gigabit LAN 1/2 Enable	Pins 1-2 (Enabled)
JPUSB1/JPUSB2	USB 0-1 Enable/USB 2-6 Enable	Pins 1-2 (Enabled)
JP3 (Optional)	Trusted Platform Module Enable	Pins 1-2 (Enabled)
JWD	Watch Dog Timer Out	Pins 1-2 (Reset)

<u>Connectors</u>	<u>Description</u>
COM1	COM Port/Serial Port 1 Connector
COM2	COM Port/Serial Port 2 Connector (J13)
Fans 1-6	Fan 6: CPU Fan, Fan 1-5: Chassis Fan Headers
JBT1	CMOS Clear
JF1	FP Control Panel Header
JL1	Chassis Intrusion Header
JLED	Onboard Power LED Indicator
JPR1	Redundant Power Alarm Reset
JPW2	12V 8-pin Power Connector (Required)
JWOL	Wake-on-LAN Header
JWOR	Wake-on-Ring Header
J9	Speaker Header
KB/MS	PS/2 Keyboard/Mouse
LAN1/LAN2	Ethernet RJ45 (Gigabit LAN) Connectors (LAN 2 only available on the LN2 model)
LE1	Standby Power LED Indicator
PCI Slot	PCI 33 MHz
PCI-E Slot	PCI-Express x4
PW Fault	Power Fault Header
PW SMB	Power SMBus
SATA 0-5	SATA Headers
SGPIO 1-2	Serial General Purpose Input Output Headers
SIM IPMI	SIM 1U IPMI Slot
Slot 6 + SBX	PCI-Express x8 slot + SBX: PCI 32-bit 33MHz slot
USB 0-1	Back Panel Universal Serial Bus Ports
USB 2-5	Front Panel Accessible USB Headers
USB 6	Front Panel USB Connector
VGA	Video Graphics Connector

Motherboard Features

Processor

- Single Intel Xeon 3000/3200 series processor with a system bus speed of 1333/1066/800 MHz
- Intel® Core™ 2 Duo and Quad Processors
- Supports Intel Dual Core Technology, Wide Dynamic Execution, FSB Dynamic Bus Inversion (DBI), Advanced Digital Media Boost, Smart Memory Access, and Thermal Management 2 (TM2)

Memory

- Four DIMM slots support Dual/Single Channel DDR2 800/667 MHz up to 8 GB of ECC/Non-ECC Unbuffered DDR2 SDRAM

Chipset

- Intel 3200
- Intel ICH9R

Expansion Slots

- One (1) Universal PCI-E x8 slot or one (1) PCI 32-bit slot
- One (1) 32-bit PCI 33MHz
- One (1) SIM 1U (Available only on X7SBL-LN2)

BIOS

- 8 Mb Firmware Hub Phoenix BIOS
- DMI 2.3, PCI 2.2, ACPI 1.0/2.0, Plug and Play (PnP), SMBIOS 2.3

PC Health Monitoring

- Onboard voltage monitors for CPU cores, Memory Voltage, +1.8V, +3.3V, +5V, +5V Standby, +12V, -12V, and VBAT
- CPU 4-phase-switching voltage regulator
- Status monitor for fan speed & System OH/Fan Fail LED/Control
- Pulse Width Modulation Fan Control & Low noise fan speed control
- Environmental temperature monitoring via BIOS
- Power-up mode control for recovery from AC power loss
- SuperDoctor III, NMI
- System Resource alert via SuperDoctor III
- Slow blinking LED for suspend state indicator
- BIOS support for USB keyboard
- Main switch override mechanism

ACPI Features

- Slow blinking LED for suspend state indicator
- BIOS support for USB keyboard
- Main switch override mechanism
- Internal/external modem ring-on

Onboard I/O

- Intel ICH9R SATA Controller, 6 connectors for 6 devices with support of RAID functions 0, 1, 5 and 10 (RAID 5: supported by Intel's RAID Controller in the Windows OS environment only)
- 1 floppy port interface (up to 2.88 MB)
- 1 Fast UART 16550 compatible serial port and 1 header
- Intel 82573V and 82573L Gigabit Ethernet Controllers (Two LANS under LAN2)
- PS/2 mouse and PS/2 keyboard ports
- Up to 7 USB (2 rear ports, 2 headers, and 1 on-board connector)
- VGA Connector
- SIM 1U IPMI Slot
- Winbond 83627HG (Super I/O), Hardware Monitor: W83793G
- XGI Volari Z9S with 32 MB DDR2

Temperature

- Monitoring CPU, chassis environment
- CPU Thermal Trip support
- Thermal Monitor 2 (TM2) (available if supported by the CPU)

Other

- Wake-on-LAN (WOL)
- Wake-on-Ring (WOR)
- Onboard +5vsb warning LED Indicator ("LE 1")
- External modem ring-on

CD Utilities

- Drivers and software for Intel 3200 chipset utilities

Dimensions

- Micro ATX form factor, 9.6" x 9.6" (243.8 x 243.8 mm)

Block Diagram

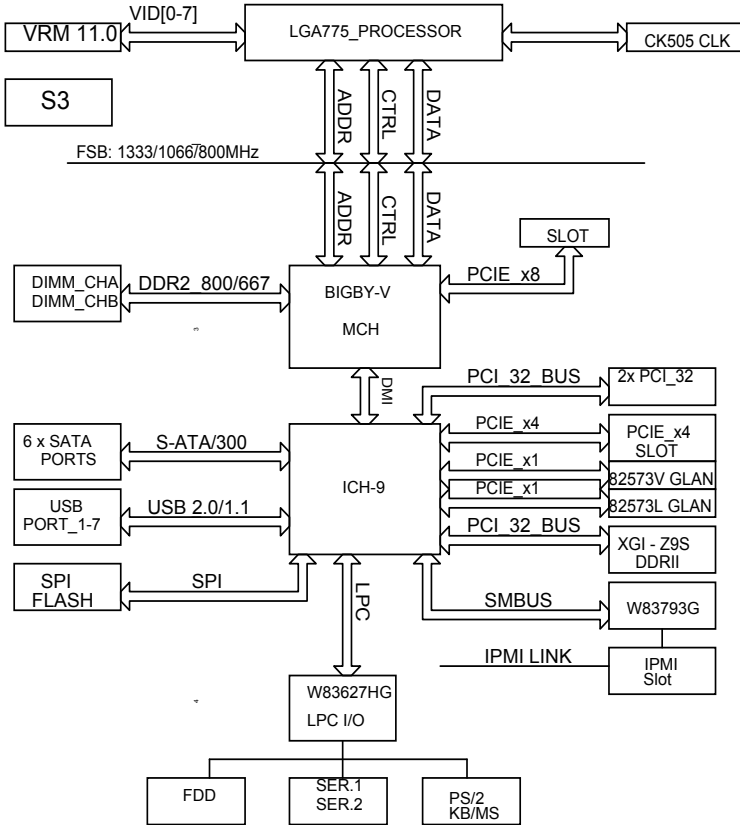

**Intel 3200 Chipset:
System Block Diagram**



Note: This is a general block diagram and may not exactly represent the features on your motherboard. See the previous pages for the actual specifications of your motherboard.

1-2 Chipset Overview

The Intel 3200 chipset, designed for use with an Intel Xeon 3000 sequence processor in the LGA 775 Land Grid Array Package, is comprised of two primary components: the Memory Controller Hub (MCH) and the I/O Controller Hub (ICH9R). The X7SBL-LN1/LN2 provides the performance and feature-set required for the mainstream server market.

Memory Controller Hub (MCH)

The function of the MCH is to manage the data flow between four interfaces: the CPU interface, the DDR2 System Memory interface, the PCI Express interface (Note 2), and the Direct Media Interface (DMI). The MCH is optimized for the Intel Xeon 3000 sequence processor in the LGA775 Land Grid Array package. It supports one or two channels of DDR2 SDRAM.

Intel ICH9R System Features

The I/O Controller (ICH9R) provides the data buffering and interface arbitration required for the system to operate efficiently. It also provides the bandwidth needed for the system to maintain its peak performance. The Direct Media Interface (DMI) provides the connection between the MCH and the ICH9R. The ICH9R supports two PCI-Express devices, six Serial ATA ports, and up to seven USB 2.0 ports/headers. In addition, the ICH9R offers the Intel Matrix Storage Technology which provides various RAID options for data protection and rapid data access. It also supports the next generation of client management through the use of PROActive technology in conjunction with Intel's next generation Gigabit Ethernet controller. Functions and capabilities include:

- Advanced Configuration and Power Interface, Version 2.0 (ACPI)
- Intel I/O External Design Specification (EDS)
- 3200 Memory Controller Hub (MCH) External Design Specification (EDS)
- Intel I/O Controller Hub 9 (ICH9R) Thermal Design Guideline
- Intel 82573 Platform LAN Connect (PLC) PCI Design



Note 1: For more information on the ICH9R, please refer to Intel's website at www.intel.com.

Note 2: The Intel 3200 chipset does not support add-in graphics cards in the PCI-E interface provided by the Memory Controller Hub (MCH)

1-3 Special Features

Recovery from AC Power Loss

BIOS provides a setting for you to determine how the system will respond when AC power is lost and then restored to the system. You can choose for the system to remain powered off (in which case you must hit the power switch to turn it back on) or for it to automatically return to a power-on state. See the Power Lost Control setting in the Advanced section to change this setting. (Default: Last State).

1-4 PC Health Monitoring

This section describes the PC health monitoring features of the X7SBL-LN1/LN2. All have an onboard System Hardware Monitor chip that supports PC health monitoring.

Onboard Voltage Monitors for the CPU Cores, Memory Voltage, +1.8V, +3.3V, +5V, +5V Standby, +12V, -12V and Vbatt.(via SuperO Doctor)

An onboard voltage monitor will scan these voltages continuously. Once a voltage becomes unstable, a warning is given or an error message is sent to the screen. Users can adjust the voltage thresholds to define the sensitivity of the voltage monitor.

Fan Status Monitor with Firmware Control

The PC health monitor can check the RPM status of the cooling fans. The onboard CPU and chassis fans are controlled by Thermal Management via BIOS (under Hardware Monitoring in the Advanced Setting).

Environmental Temperature Control

The thermal control sensor monitors the CPU temperature in real time and will turn on the thermal control fan whenever the CPU temperature exceeds a user-defined threshold. The overheat circuitry runs independently from the CPU. Once it detects that the CPU temperature is too high, it will automatically turn on the thermal fan control to prevent any overheat damage to the CPU. The onboard chassis thermal circuitry can monitor the overall system temperature and alert users when the chassis temperature is too high.

I/O Virtualization Technology

With the Intel ICH9R built in, the X7SBL-LN1/LN2 supports I/O Virtualization Technology (VT-d) that enables multiple operating systems and applications to run in independent partitions. Each partition uses its own subset of host physical memory, and behaves like a virtual machine (VM), providing isolation and protection across multiple partitions. This feature is available when a processor that supports I/O Virtualization Technology is installed on the motherboard.

CPU Overheat LED and Control

This feature is available when the user enables the CPU overheat warning function in the BIOS. This allows the user to define an overheat temperature. When this temperature is exceeded, both the overheat fan and the warning LED are triggered.

System Resource Alert

This feature is available when used with Supero Doctor III in the Windows OS environment or used with Supero Doctor II in Linux. Supero Doctor is used to notify the user of certain system events. For example, if the system is running low on virtual memory and there is insufficient hard drive space for saving the data, you can be alerted of the potential problem. You can also configure Supero Doctor to provide you with warnings when the system temperature goes beyond a pre-defined range.

1-5 ACPI Features

ACPI stands for Advanced Configuration and Power Interface. The ACPI specification defines a flexible and abstract hardware interface that provides a standard way to integrate power management features throughout a PC system, including its hardware, operating system and application software. This enables the system to automatically turn on and off peripherals such as CD-ROMs, network cards, hard disk drives and printers. This also includes consumer devices connected to the PC such as VCRs, TVs, telephones and stereos.

In addition to enabling operating system-directed power management, ACPI provides a generic system event mechanism for Plug and Play and an operating system-independent interface for configuration control. ACPI leverages the Plug and Play BIOS data structures while providing a processor architecture-independent implementation that is compatible with Windows 2000, Windows XP and Windows 2003 Server Operating Systems.

Slow Blinking LED for Suspend-State Indicator

When the CPU goes into a suspend state, the chassis power LED will start blinking to indicate that the CPU is in suspend mode. When the user presses any key, the CPU will wake-up and the LED will automatically stop blinking and remain on.

1-6 Super I/O

The disk drive adapter functions of the Super I/O chip include a data separator, write pre-compensation circuitry, decode logic, data rate selection, a clock generator, drive interface control logic and interrupt and DMA logic. The Super I/O supports two 360 K, 720 K, 1.2 M, 1.44 M or 2.88 M disk drives and data transfer rates of 250 Kb/s, 500 Kb/s or 1 Mb/s.

It also provides two high-speed, 16550 compatible serial communication ports (UARTs). Each UART includes a 16-byte send/receive FIFO, a programmable baud rate generator, complete modem control capability and a processor interrupt system. Both UARTs provide legacy speed with baud rate of up to 115.2 Kbps as well as an advanced speed with baud rates of 250 K, 500 K, or 1 Mb/s, which support higher speed modems.

The Super I/O provides functions that comply with the ACPI (Advanced Configuration and Power Interface), which includes support of legacy and ACPI power management through a SMI or SCI function pin. It also features auto power management to reduce power consumption.

Chapter 2

Installation

2-1 Static-Sensitive Devices

Electrostatic-Discharge (ESD) can damage electronic components. To prevent damage to your system board, it is important to handle it very carefully. The following measures are generally sufficient to protect your equipment from ESD.

Precautions

- Use a grounded wrist strap designed to prevent static discharge.
- Touch a grounded metal object before removing the board from the antistatic bag.
- Handle the board by its edges only; do not touch its components, peripheral chips, memory modules or gold contacts.
- When handling chips or modules, avoid touching their pins.
- Put the motherboard and peripherals back into their antistatic bags when not in use.
- For grounding purposes, make sure your computer chassis provides excellent conductivity between the power supply, the case, the mounting fasteners and the motherboard.
- Use only the correct type of onboard CMOS battery as specified by the manufacturer. Do not install the onboard battery upside down to avoid possible explosion.

Unpacking

The motherboard is shipped in antistatic packaging to avoid static damage. When unpacking the board, make sure the person handling it is static protected.

2-2 Motherboard Installation



Note: Be sure to mount the motherboard into the chassis before you install the CPU onto the motherboard.

All motherboards have standard mounting holes to fit different types of chassis. Make sure that the locations of all the mounting holes for both motherboard and chassis match. Make sure that the metal standoffs click in or are screwed in tightly. Then use a screwdriver to secure the motherboard onto the motherboard tray.



Note: Some components are very close to the mounting holes. Please take precautionary measures to prevent damage to these components when installing the motherboard to the chassis.

2-3 Processor and Heatsink Installation



Warning: When handling the processor package, avoid placing direct pressure on the label area of the fan.



Notes:

1. Always connect the power cord last and always remove it before adding, removing or changing any hardware components. Make sure that you install the processor into the CPU LGA 775 socket before you install the CPU heatsink.
2. The Intel LGA 775 Processor package contains the CPU fan and heatsink assembly. If you buy a CPU separately, make sure that you use only Intel-certified multi-directional heatsink and fan.
3. Make sure to install the motherboard into the chassis before you install the CPU heatsink and fan.
4. When purchasing an LGA 775 Processor or when receiving a motherboard with an LGA 775 Processor pre-installed, make sure that the CPU plastic cap is in place and none of the CPU pins are bent; otherwise, contact the retailer immediately.
5. Refer to the MB Features Section for more details on CPU support.

Installation Overview

For proper system setup, please follow the following procedure:

1. Install the heatsink backplate into the chassis if needed.
2. Install the motherboard into the chassis.
3. Install the CPU onto the motherboard.
4. Install the heatsink and/or cooling fans (if any).
5. Connect the fan and power cables (if any).

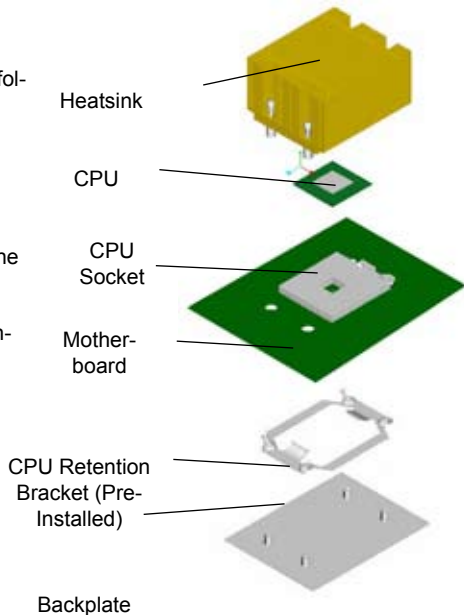

Installation of the LGA 775 Processor

1. Press the load lever to release the load plate, which covers the CPU socket, from its locking position.

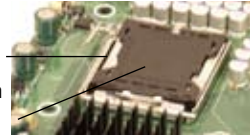

PnP Cap on top of the Load Plate



2. Gently lift the load lever to open the load plate.



Load Plate (with PnP Cap attached)



3. Use your thumb and your index finger to hold the CPU at the top center edge and the bottom center edge of the CPU.

Triangle

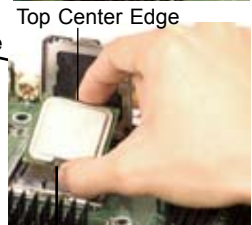

4. Align CPU Pin1 (the CPU corner marked with a triangle) against the socket corner that is marked with a triangle cutout.

Bottom Center Edge

Socket Key (Socket Notch)
CPU Key (semi-circle cutout) below the circle.

Corner with a triangle cutout

golden dot

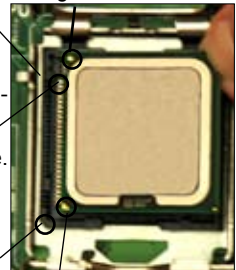

CPU Pin1

5. Align the CPU key that is the semi-circle cutout below a golden dot against the socket key, the Notch on the same side of the triangle cutout on the socket.

6. Once aligned, carefully lower the CPU straight down to the socket. (**Do not drop the CPU on the socket. Do not move the CPU horizontally or vertically. Do not rub the CPU against the surface or against any pins of the socket to avoid damage to the CPU or the socket.)

7. With the CPU inside the socket, inspect the four corners of the CPU to make sure that the CPU is properly installed.

8. Use your thumb to gently push the load lever down to the lever lock.

9. If the CPU is properly installed into the socket, the plastic PnP cap will be automatically released from the load plate when the load lever is pushed in the lever lock. Remove the PnP cap from the motherboard.



Note: Please save the plastic PnP cap. The motherboard must be shipped with the PnP cap properly installed to protect the CPU socket pins. Shipment without the PnP cap properly installed will cause damage to the socket pins.

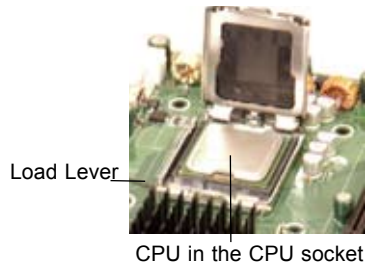

Plastic cap is released from the load plate if CPU properly installed.



Installation of the Heatsink

1. Do not apply any thermal grease to the heatsink or the CPU die, the required amount has already been applied.

2. Place the heatsink on top of the CPU so that the four mounting holes are aligned with those on the retention mechanism.

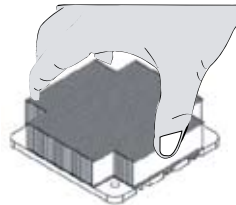

⚠ Do not reuse thermal grease!

3. Screw in two diagonal screws (eg. the #1 and the #2 screws) until just snug (do not fully tighten the screws, which may damage the CPU).

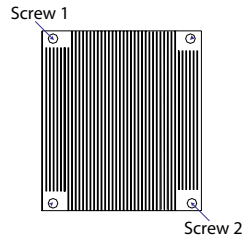

4. Finish the installation by fully tightening all four screws.

Removal of the Heatsink



Warning: We do not recommend that the CPU or the heatsink be removed. However, if you do need to uninstall the heatsink, please follow these instructions below to prevent damage to the CPU or the CPU socket.

1. Unscrew and remove the heatsink screws from in the sequence as show in the picture on the right.
2. Hold and gently wriggle the heatsink to loosen it from the CPU. (Do not use excessive force when loosening the heatsink!)
3. Once the heatsink is loosened, remove it from the CPU socket.
4. Clean the surfaces of the CPU and the heatsink to remove the old thermal grease. Reapply the proper amount of thermal grease on the surface before re-installing the CPU and the heatsink.

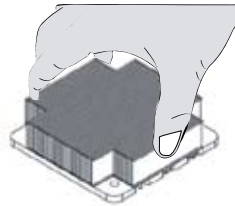
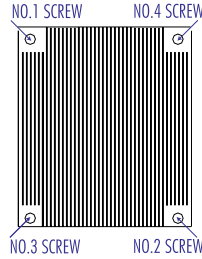

Do not reuse thermal grease!

2-4 Installing DIMMs



Note: Check the Supermicro web site for recommended memory modules.



Warning: Exercise extreme care when installing or removing DIMM modules to prevent any possible damage. Also note that the memory is interleaved to improve performance (see step 1).

DIMM Installation

1. Insert the desired number of DIMMs into the memory slots, starting with DIMM1A. The memory scheme is interleaved so you must install two modules at a time, beginning with DIMM1A, DIMM1B, then, DIMM2A and DIMM2B
2. Insert each DIMM module vertically into its slot. Pay attention to the notch along the bottom of the module to prevent inserting the DIMM module incorrectly.
3. Gently press down on the DIMM module until it snaps into place in the slot. Repeat for all modules (see step 1 above).

Memory Support

The X7SBL-LN1/LN2 supports up to 8 GB Unbuffered ECC or non-ECC DDR2 800/677 MHz in 4 DIMMs. Populating DIMM#1A, DIMM#1B, and/or DIMM#2A, DIMM#2B with memory modules of the same size and of the same type will result in dual channel, two-way interleaved memory which is faster than the single channel, non-interleaved memory.



Notes:

1. Due to the OS limitations, some operating systems may not show more than 4GB of memory.
 2. Both Unbuffered ECC and Non-ECC memory modules can be installed in the memory slots.
 3. Due to memory allocation to system devices, memory remaining available for operational use will be reduced when 4 GB of RAM is used. The reduction in memory availability is disproportional. (Refer to the following Memory Availability Table for details.)
-

Possible System Memory Allocation & Availability		
System Device	Size	Physical Memory Remaining (-Available) (4 GB Total System Memory)
Firmware Hub flash memory (System BIOS)	1 MB	3.99
Local APIC	4 KB	3.99
Area Reserved for the chipset	2 MB	3.99
I/O APIC (4 Kbytes)	4 KB	3.99
PCI Enumeration Area 1	256 MB	3.76
PCI Express (256 MB)	256 MB	3.51
PCI Enumeration Area 2 (if needed) -Aligned on 256-MB boundary-	512 MB	3.01
VGA Memory	16 MB	2.85
TSEG	1 MB	2.84
Memory available to OS and other applications		2.84

Installing and Removing DIMMs

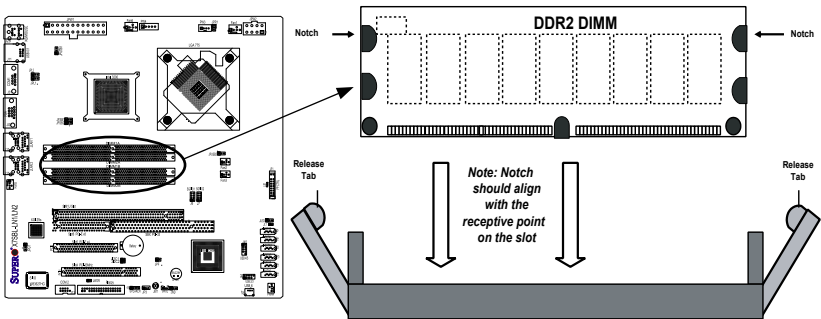

To Install: Insert module vertically and press down until it snaps into place. Pay attention to the alignment notch at the bottom.

To Remove: Use your thumbs to gently push the release tabs near both ends of the module. This should release it from the slot.

Top View of DDR2

Top View of DDR2 Slot

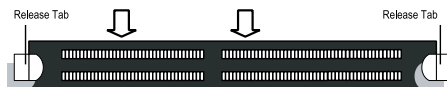

2-5 Control Panel Connectors/IO Ports

The I/O ports are color coded in conformance with the PC 99 specification. See the image below for the colors and locations of the various I/O ports.

1. Back Panel Connectors/IO Ports

Back Panel I/O Port Locations and Definitions

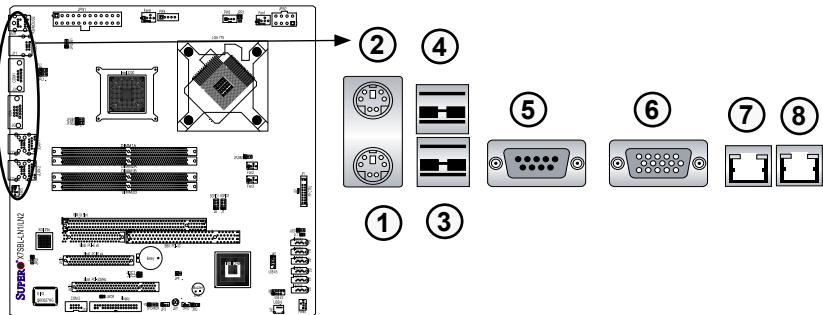

Back Panel Connectors

1. Keyboard (Purple)
2. PS/2 Mouse (Green)
3. Back Panel USB Port 0
4. Back Panel USB Port 1
5. COM Port 1 (Turquoise)
6. VGA Port (Blue)
7. Gigabit LAN 1
8. Gigabit LAN 2 (X7SBL-LN2 only)

(*See Section 2-5 for details.)

2. Front Control Panel

JF1 contains header pins for various buttons and indicators that are normally located on a control panel at the front of the chassis. See the image below for the descriptions of the various control panel buttons and LED indicators. Refer to the following section for descriptions and pin definitions.

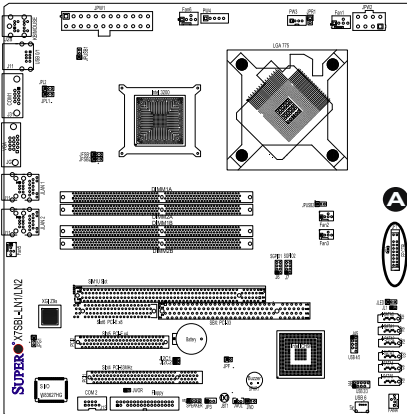

A. JF1

Header Pins

	20	19	
Ground	○	○	NMI
X	○	○	X
Power LED	○	○	Vcc
HDD LED	○	○	Vcc
NIC1 LED	○	○	Vcc
NIC2 LED	○	○	Vcc
OH/Fan Fail LED	○	○	Vcc
PWR Fail LED	○	○	Vcc
Ground	○	○	FP Reset Button
Ground	○	○	FP Power Button
	2	1	

3. Front Control Panel Pin Definitions

NMI Button

The non-maskable interrupt button header is located on pins 19 and 20 of JF1. Refer to the table on the right for pin definitions.

NMI Button Pin Definitions (JF1)	
Pin#	Definition
19	Control
20	Ground

Power LED

The Power LED connection is located on pins 15 and 16 of JF1. Refer to the table on the right for pin definitions.

Power LED Pin Definitions (JF1)	
Pin#	Definition
15	+5V
16	Ground

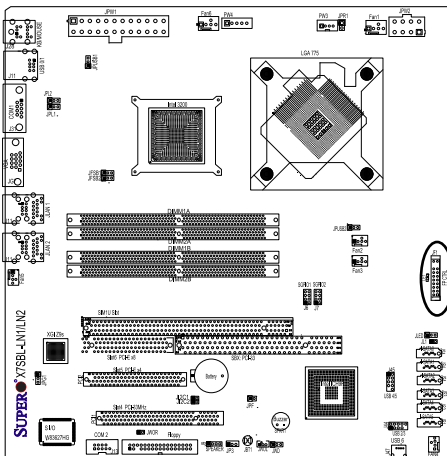

A. NMI

B. PWR LED

Header Pins

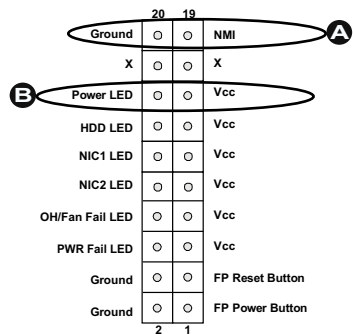

NIC1/NIC2 LED Indicators

The NIC (Network Interface Controller) LED connection for GLAN 1 is located on pins 11 and 12 of JF1 and the LED connection for GLAN 2 is on Pins 9 and 10. Attach the NIC LED cables to display network activity. Refer to the table on the right for pin definitions.

GLAN 1 LED Pin Definitions (JF1)	
Pin#	Definition
11	LED_Anode+
12	NIC1 LED Signal

GLAN 2 LED Pin Definitions (JF1)	
Pin#	Definition
9	LED_Anode+
10	NIC1 LED Signal

HDD LED

The HDD LED connection is located on pins 13 and 14 of JF1. Attach the hard drive LED cable here to display disk activity (for any hard drives on the system, including SAS, Serial ATA and IDE, if available). See the table on the right for pin definitions.

HDD LED Pin Definitions (JF1)	
Pin#	Definition
13	+5V
14	HD Active

- A. HDD LED
- B. NIC1 LED
- C. NIC2 LED

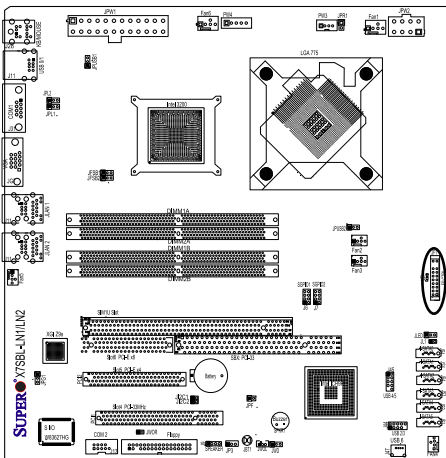

Header Pins

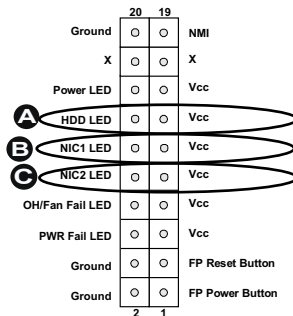

Overheat/Fan Fail LED (OH)

Connect an LED to the OH/Fan Fail connection on pins 7 and 8 of JF1 to provide advanced warning of chassis overheating or fan failure. Refer to the table on the right for pin definitions.

OH/Fan Fail Indicator Status	
State	Definition
Off	Normal
On	Overheat
Flashing	Fan Fail

Power Fail LED

The Power Fail LED connection is located on pins 5 and 6 of JF1. Refer to the table on the right for pin definitions.

PWR Fail LED Pin Definitions (JF1)	
Pin#	Definition
5	Vcc
6	PWR Fail

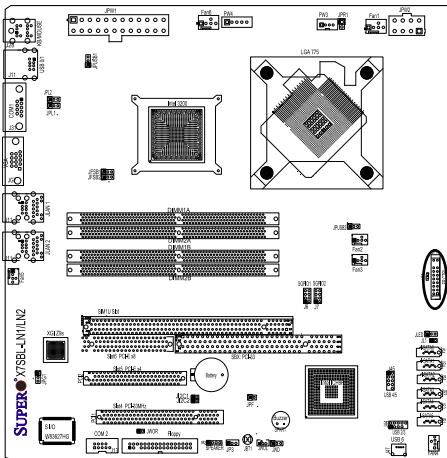

A. OH/Fan Fail LED

B. PWR Supply Fail

Header Pins

	20	19	
Ground	○	○	NMI
X	○	○	X
Power LED	○	○	Vcc
HDD LED	○	○	Vcc
NIC1 LED	○	○	Vcc
NIC2 LED	○	○	Vcc
A OH/Fan Fail LED	○	○	Vcc
PWR Fail LED	○	○	Vcc
Ground	○	○	FP Reset Button
B Ground	○	○	FP Power Button

Reset Button

The Reset Button connection is located on pins 3 and 4 of JF1. Attach it to the hardware reset switch on the computer case. Refer to the table on the right for pin definitions.

Reset Button Pin Definitions (JF1)	
Pin#	Definition
3	Reset
4	Ground

Power Button

The Power Button connection is located on pins 1 and 2 of JF1. Momentarily contacting both pins will power on/off the system. This button can also be configured to function as a suspend button (with a setting in the BIOS - see Chapter 4). To turn off the power when set to suspend mode, press the button for at least 4 seconds. Refer to the table on the right for pin definitions.

Power Button Pin Definitions (JF1)	
Pin#	Definition
1	Signal
2	+3V Standby

- A. Reset Button
- B. PWR Button

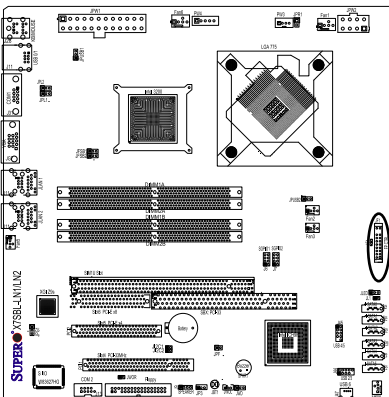

Header Pins

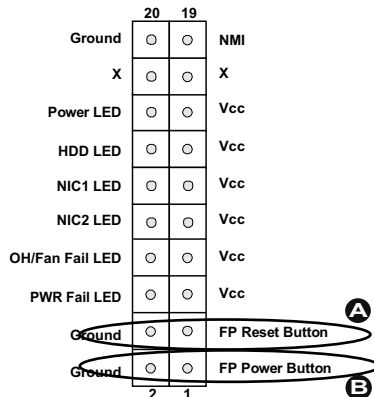

2-6 Connecting Cables

ATX Power Connector

There are a 24-pin main power supply connector(JPW1) and an 8-pin CPU PWR connector (JPW2) on the motherboard. These power connectors meet the SSI EPS 12V specification. For the 8-pin PWR (JPW2), please refer to the item listed below.

ATX Power 24-pin Connector Pin Definitions			
Pin#	Definition	Pin #	Definition
13	+3.3V	1	+3.3V
14	-12V	2	+3.3V
15	COM	3	COM
16	PS_ON	4	+5V
17	COM	5	COM
18	COM	6	+5V
19	COM	7	COM
20	Res (NC)	8	PWR_OK
21	+5V	9	5VSB
22	+5V	10	+12V
23	+5V	11	+12V
24	COM	12	+3.3V

Processor Power Connector

In addition to the Primary ATX power connector (above), the 12V 8-pin CPU PWR connector at JPW2 must also be connected to your power supply. See the table on the right for pin definitions.

12V 8-pin Power CPU Connector Pin Definitions (JPW2)	
Pins	Definition
1 through 4	Ground
5 through 8	+12V

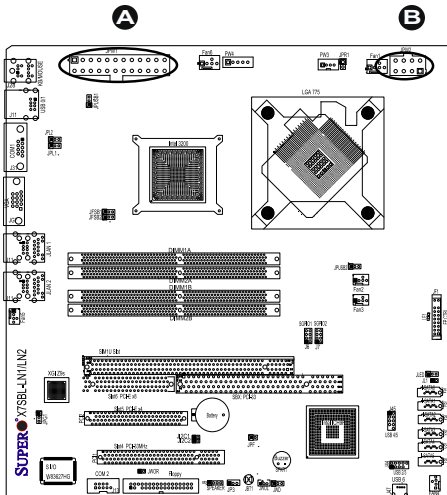

A. JPW1

B. JPW2

Universal Serial Bus (USB)

There are seven USB 2.0 (Universal Serial Bus) ports/headers on the motherboard. Two of them are Back Panel USB ports (USB 0-1: J15). Another two USB Headers: (USB 2-3: J44) and (USB 4-5 : J45) can provide front access USB connections. (FP USB 6: J47) is a front panel USB connection. See the tables on the right for pin definitions.

Back Panel USB (J15)	
Pin#	Definitions
1	+5V
2	PO-
3	PO+
4	Ground
5	N/A

Front Panel & Front Accessible USB Pin Definitions (J44, J45, J47)			
USB 2, USB 4, USB 6		USB 3, USB 5	
Pin #	Definition	Pin #	Definition
1	+5V	1	+5V
2	PO-	2	PO-
3	PO+	3	PO+
4	Ground	4	Ground
5	No connection	5	Key

Chassis Intrusion

A Chassis Intrusion header is located at JL1 on the motherboard. Attach an appropriate cable from the chassis to inform you of a chassis intrusion when it is opened.

Chassis Intrusion Pin Definitions (JL1)	
Pin#	Definition
1	Intrusion Input
2	Ground

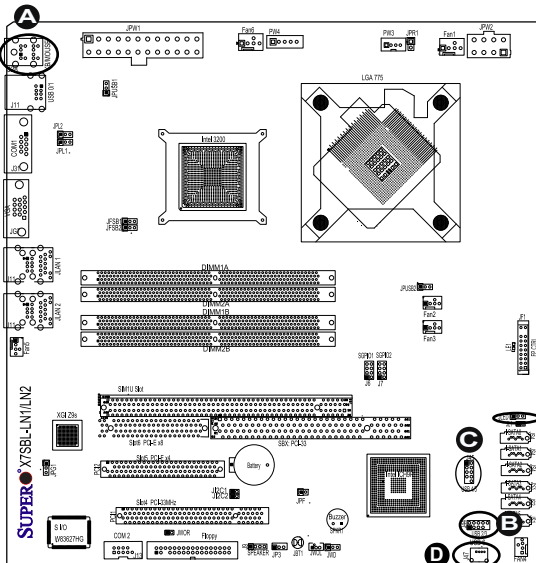

- A. Backpanel USB 0-1
- B. Front Accessible USB 2-3
- C. Front Accessible USB 4-5
- D. Front Panel USB 6
- E. Chassis Intrusion

ATX PS/2 Keyboard and PS/2 Mouse Ports

The ATX PS/2 keyboard and the PS/2 mouse are located at J28. See the table on the right for pin definitions. (The mouse port is above the keyboard port. See the table on the right for pin definitions.)

PS/2 Keyboard and Mouse Port Pin Definitions	
Pin#	Definition
1	Data
2	NC
3	Ground
4	VCC
5	Clock
6	NC

Serial Ports

COM1 (J31) is a connector located on the IO Backpanel and COM2 is a header located at J13. See the table on the right for pin definitions.

Serial Port Pin Definitions			
Pin #	Definition	Pin #	Definition
1	DCD	6	DSR
2	RXD	7	RTS
3	TXD	8	CTS
4	DTR	9	RI
5	Ground	10	NC

(Pin 10 is available on COM2 only. NC: No Connection.)

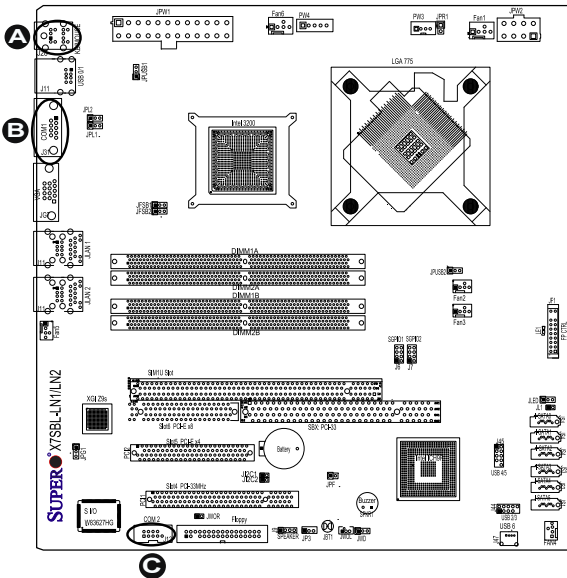

- A. Keyboard/Mouse
- B. COM1
- C. COM2

Power LED

The Power LED connector is located at JLED. This connection is used to provide LED Indication of power being supplied to the system. See the table on the right for pin definitions.

PWR LED Pin Definitions	
Pin#	Definition
1	+5V
2	Key
3	Ground

External Speaker/Internal Buzzer

On the J9 header, pins 1-4 are for an External Speaker and pins 3-4 are for the Internal Buzzer. See the table on the right for speaker pin definitions.

Speaker Connector	
Pin Setting	Definition
Pins 3-4	Internal Speaker
Pins 1-4	External Speaker



Note: Connect a cable to pins 1-4 to use an external speaker. If you wish to use the onboard buzzer, you should close pins 3-4 with a cap.

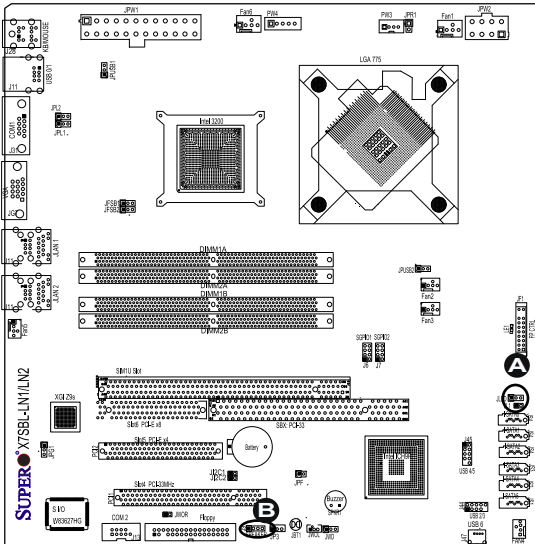

- A. PWR LED
- B. Speaker

GLAN (Giga-bit Ethernet Ports)

Two G-bit Ethernet ports (GLAN1/GLAN2) are located next to the VGA Connector on the IO backplane. These ports accept RJ45 type cables.



VGA Connector

A VGA connector (J16) is located between COM1 and GLAN1 on the IO backplane. Refer to the board layout below for the location.

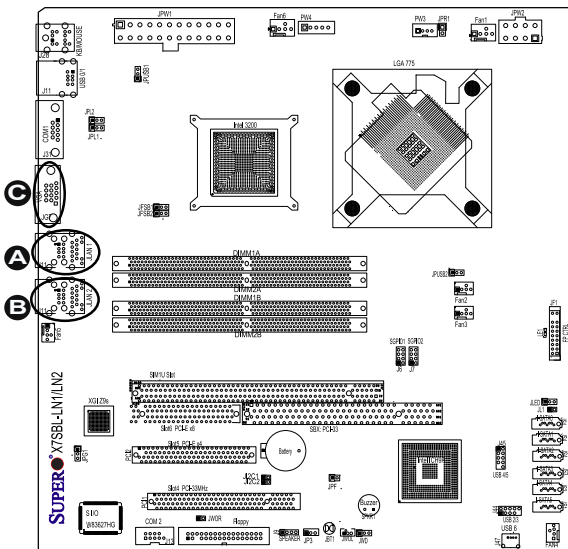

- A. GLAN1
- B. GLAN2
- C. VGA

Fan Headers

The X7SBL-LN1/LN2 has six fan headers (Fan1 to Fan6) including five chassis/system fan headers (Fan1 to Fan5) and one CPU Fan (CPU Fan6). All these fan headers support 4-pin fans. However, Pins 1-3 of the fan headers are backward compatible with the traditional 3-pin fans. See the table on the right for pin definitions. The onboard fan speeds are controlled by Thermal Management via BIOS Hardware Monitoring in the Advanced Setting.

4-pin Fan Header Pin Definitions (Fan1-6)	
Pin#	Definition
1	Ground
2	+12V
3	Tachometer
4	PWR Modulation

Notes:

1. The Default setting is Disabled.
2. Please use all 3-pin fans or all 4-pin fans on the motherboard. Please do not use 3-pin fans and 4-pin fans on the same board.)

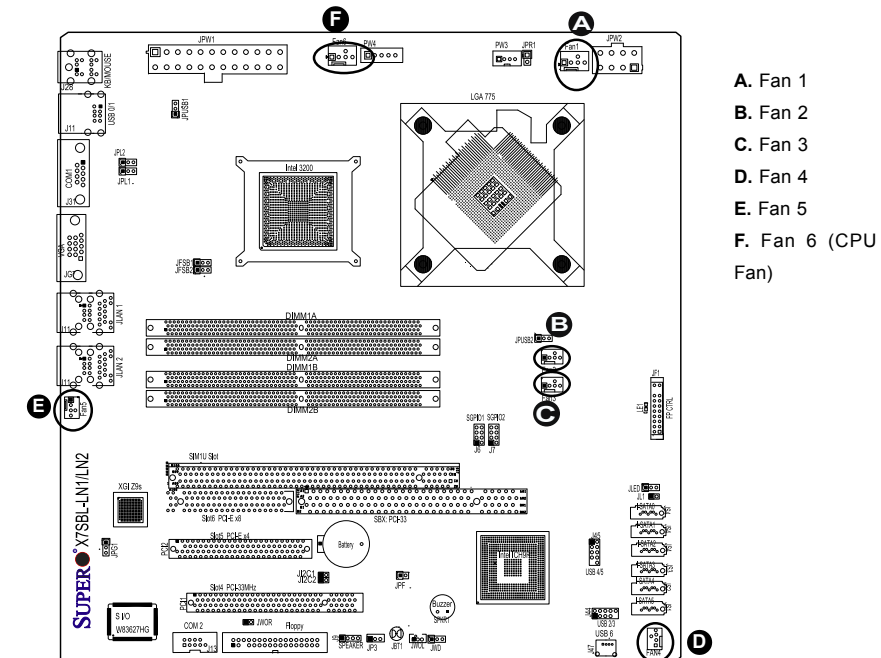

- A. Fan 1
- B. Fan 2
- C. Fan 3
- D. Fan 4
- E. Fan 5
- F. Fan 6 (CPU Fan)

Wake-On-Ring

The Wake-On-Ring header is located at JWOR. This feature allows your computer to be awakened by an incoming call to the modem when the system is in the suspend state. See the table on the right for pin definitions. You must have a Wake-On-Ring card and a cable to use this feature.

Wake-On-Ring Pin Definitions (JWOR)

Pin#	Definition
1	Ground
2	Wake-up

Wake-On-LAN

The Wake-On-LAN header is located at JWOL on the motherboard. See the table on the right for pin definitions. (You must also have a LAN card with a Wake-On-LAN connector and cable to use this feature.)

Wake-On-LAN Pin Definitions (JWOL)

Pin#	Definition
1	+5V Standby
2	Ground
3	Wake-up

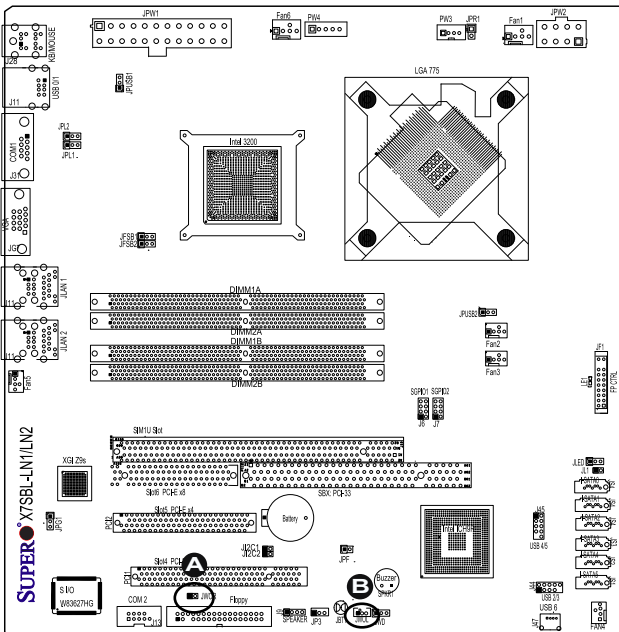

- A. WOR
- B. WOL

Power Fault (PWR Supply Failure)

Connect a cable from your power supply to the Power Fail (PW3) header to provide a warning in the event of a power supply failure. This warning signal is passed through the PWR_LED pin to indicate of a power failure on the chassis. See the table on the right for pin definitions.

PWR Supply Fail Pin Definitions	
Pin#	Definition
1	PWR 1: Fail
2	PWR 2: Fail
3	PWR 3: Fail
4	Signal: Alarm Reset

Note: This feature is only available when using Super Micro redundant power supplies.

Power SMB Connector

Power SMB Connector (PW4) is used to monitor PWR supply, fan and system temperature. See the table on the right for pin definitions.

PWR SMB Pin Definitions	
Pin#	Definition
1	Clock
2	Data
3	PWR Fail
4	Ground
5	+3.3V

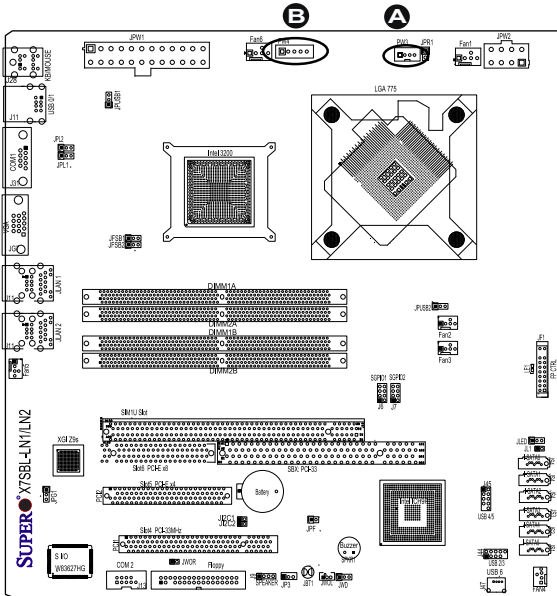

- A. PWR Fault
- B. PWR SMB

2-7 Jumper Settings

Explanation of Jumpers

To modify the operation of the motherboard, jumpers can be used to choose between optional settings. Jumpers create shorts between two pins to change the function of the connector. Pin 1 is identified with a square solder pad on the printed circuit board. See the motherboard layout pages for jumper locations.

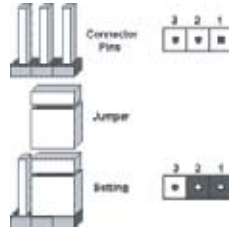

Note: On two pin jumpers, "Closed" means the jumper is on and "Open" means the jumper is off the pins.

GLAN Enable/Disable

Both JPL1 and JPL2 enable or disable the GLAN Port on the motherboard. See the table on the right for jumper settings. The default setting is enabled.

GLAN Enable	
Pin#	Definition
1-2	Enabled (*default)
2-3	Disabled

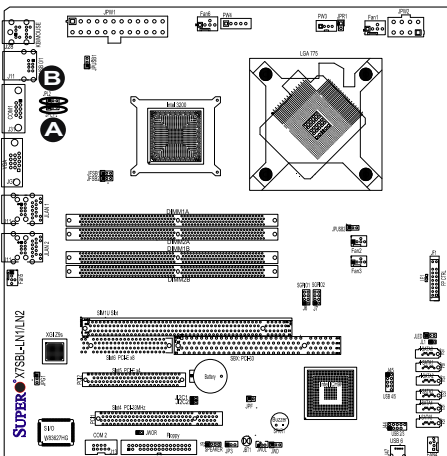

- A. GLAN Port 1 Enable
- B. GLAN Port 2 Enable

Clear CMOS

JBT1 is used to clear CMOS. Instead of pins, this "jumper" consists of contact pads to prevent the accidental clearing of CMOS. To clear CMOS, use a metal object such as a small screwdriver to touch both pads at the same time to short the connection. Always remove the AC power cord from the system before clearing CMOS.



Note: For an ATX power supply, you must completely shut down the system, remove the AC power cord and then close pins 1 and 2 to clear CMOS.



Watch Dog Enable/Disable

JWD controls the Watch Dog function. Watch Dog is a system monitor that can reboot the system when a software application hangs. Close pins 1-2 to reset the system if an application hangs. Close pins 2-3 to generate a non-maskable interrupt signal for the application that hangs. See the table on the right for jumper settings. Watch Dog must also be enabled in the BIOS.

Watch Dog Jumper Settings (JWD)	
Jumper Setting	Definition
Pins 1-2	Reset (*default)
Pins 2-3	NMI
Open	Disabled



Note: When enabled, the user needs to write his/her own application software to disable the Watch Dog Timer.

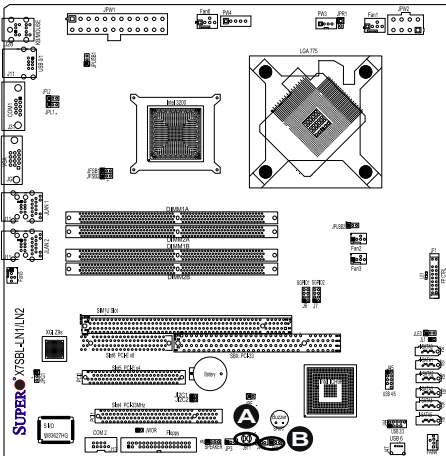

- A. Clear CMOS
- B. Watch Dog Enable

PCI/PCI-E Slots to SMB Speeds

Jumpers JI²C1/JI²C2 allow you to connect PCI/PCI-Exp. Slots to the System Management Bus. The default setting is open to disable the connection. See the table on the right for jumper settings.

SMBus to PCI-X/PCI-Exp Slots Jumper Settings	
Jumper Setting	Definition
Closed	Enabled
Open	Disabled (*Default)

VGA Enable/Disable

JPG1 enables or disables the VGA Connector on the motherboard. See the table on the right for jumper settings. The default setting is enabled.

VGA Enable	
Pin#	Definition
Pins 1-2	Enabled (*default)
Pins 2-3	Disabled

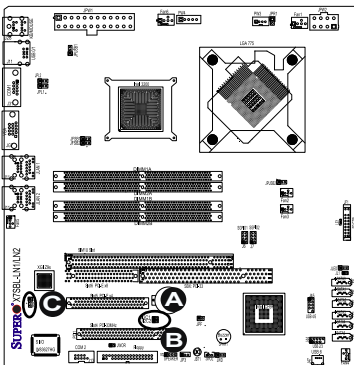

- A. JI²C1
- B. JI²C2
- C. JPG1

Force-Power-On Enable/Disable

Jumper JPF allows you to enable or disable the function of Force-Power-On. If enabled, the power will always stay on automatically. If this function is disabled, the user needs to press the power button to power on the system.

Power Force On Jumper Settings	
Pin#	Definition
Off	Normal
On	Force On

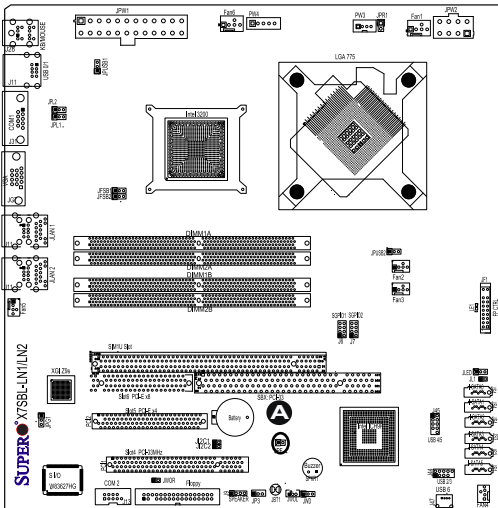

A. PWR Force On

USB Wake-Up

Use JPUSB jumpers to enable the function of "System Wake-Up via USB devices", which allows you to "wake-up" the system by pressing a key on the USB keyboard or by clicking the USB mouse of your system. The JPUSB jumpers are used together with the USB Wake-Up function in the BIOS. Enable both the jumpers and the BIOS setting to allow the system to "wake-up via USB Devices". See the table on the right for jumper settings and jumper connections. (*JPUSB1 is for Back Panel USB ports:0/1, and JPUSB2 is for Front Panel USB ports:2/3/4/5/6.*)



Note: The default jumper setting for the USB ports located on the back panel is "Enabled". However, when the "USB Wake-Up" function is enabled in the BIOS and the desired USB ports are enabled via the JPUSB jumper, please be sure to remove all USB devices from the USB ports whose USB jumpers are set to "Disabled" before the system goes into the standby mode.

JPUSB2 (Front Panel USB Wake-up)	
Pin#	Definition
1-2	Enabled
2-3	Disabled (*default)

JPUSB1 (Back Panel USB Wake-up)	
Pin#	Definition
1-2	Enabled (*default)
2-3	Disabled

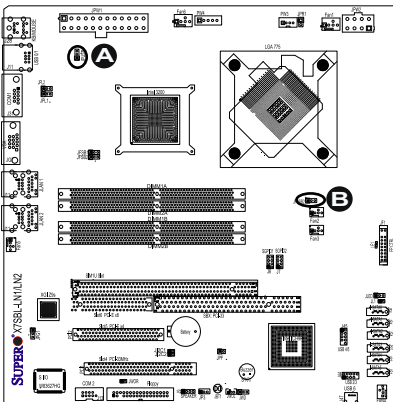

- A. JPUSB1
- B. JPUSB2

2-8 Onboard Indicators

GLAN LEDs

There are two GLAN ports on the motherboard. Each Gigabit Ethernet LAN port has two LEDs. The yellow LED indicates activity, while the Link LED may be green, amber or off to indicate the speed of the connection. See the tables at right for more information.

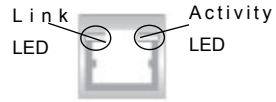

(***Rear View**: When viewing it from the rear side of the chassis)

GLAN Activity Indicator		
Color	Status	Definition
Yellow	Flashing	Active

GLAN Link Indicator	
LED Color	Definition
Off	No Connection or 10 Mbps
Green	100 Mbps
Amber	1 Gbps

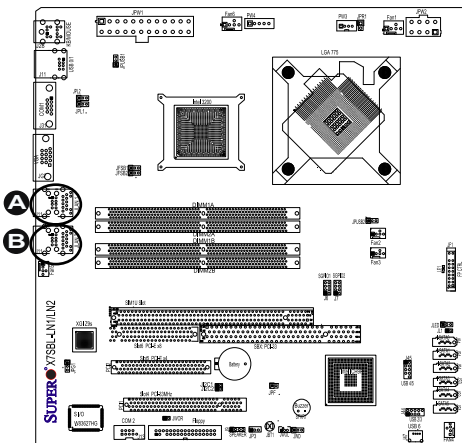

- A. GLAN1
- B. GLAN2

Onboard Power LED (LE1)

The Onboard 3.3V Standby Power LED is located at LE1 on the motherboard. When LE1 is off, the system is off. When the LED is on, the power is on. Unplug the power cable before removing or installing components. See the layout below for the LED location.

Onboard PWR LED Indicator (LE1)

LED Color	Definition
Off	System Off
On	Standby Power On
Green	System On

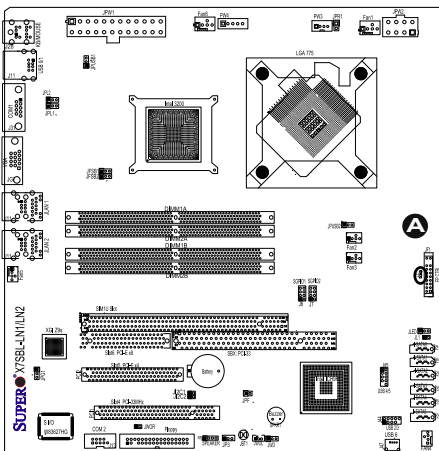

A. Power LED

2-9 Floppy and SIM 1U IPMI Connections

Note the following when connecting the floppy and hard disk drive cables:

- The floppy disk drive cable has seven twisted wires.
- A red mark on a wire typically designates the location of pin 1.
- A single floppy disk drive ribbon cable has two connectors to provide for two floppy disk drives. The connector with twisted wires always connects to drive A, and the connector that does not have twisted wires always connects to drive B.

Floppy Connector

The floppy connector is located at J27. See the table below for pin definitions.

Floppy Drive Connector Pin Definitions (Floppy)			
Pin#	Definition	Pin #	Definition
1	Ground	2	FDHDIN
3	Ground	4	Reserved
5	Key	6	FDEDIN
7	Ground	8	Index
9	Ground	10	Motor Enable
11	Ground	12	Drive Select B
13	Ground	14	Drive Select B
15	Ground	16	Motor Enable
17	Ground	18	DIR
19	Ground	20	STEP
21	Ground	22	Write Data
23	Ground	24	Write Gate
25	Ground	26	Track 00
27	Ground	28	Write Protect
29	Ground	30	Read Data
31	Ground	32	Side 1 Select
33	Ground	34	Diskette

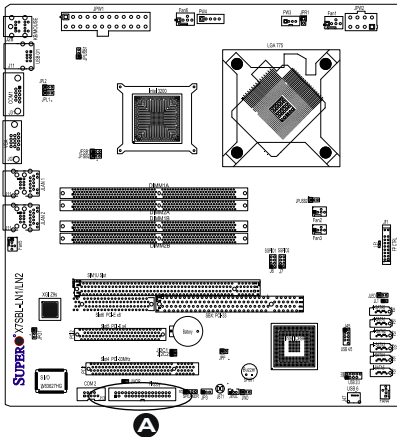

A. Floppy

Notes

Chapter 3

Troubleshooting

3-1 Troubleshooting Procedures

Use the following procedures to troubleshoot your system. If you have followed all of the procedures below and still need assistance, refer to the 'Technical Support Procedures' and/or 'Returning Merchandise for Service' section(s) in this chapter. Always disconnect the AC power cord before adding, changing or installing any hardware components.

Before Power On

1. Make sure that there are no short circuits between the motherboard and chassis.
2. Disconnect all ribbon/wire cables from the motherboard, including those for the keyboard and mouse.
3. Remove all add-on cards.
4. Install a CPU and heatsink (making sure it is fully seated) and connect the chassis speaker and the power LED to the motherboard. Check all jumper settings as well.
5. Use the correct type of onboard CMOS battery as specified by the Manufacturer. Do not install the CMOS battery upside down to avoid possible explosion.
6. Make sure the 4-pin 12v power connector at J41 is connected to your power supply.

No Power

1. Make sure that there are no short circuits between the motherboard and chassis.
2. Verify that all jumpers are set to their default positions.

3. Check that the 115V/230V switch on the power supply is properly set.
4. Turn the power switch on and off to test the system.
5. The battery on your motherboard may be old. Check to verify that it still supplies ~3VDC. If it does not, replace it with a new one.

No Video

1. If the power is on but you have no video, remove all the add-on cards and cables.
2. Use the speaker to determine if any beep codes exist. Refer to Appendix A for details on beep codes.



Note: If you are a system integrator, VAR or OEM, a POST diagnostics card is recommended. For I/O port 80h codes, refer to App. B.

Memory Errors

1. Make sure that the DIMM modules are properly and fully installed.
2. You should be using unbuffered DDR2 memory (see the next page). Also, it is recommended that you use the same memory speed for all DIMMs in the system. See Section 2-4 for memory limitations.
3. Check for bad DIMM modules or slots by swapping modules between slots and noting the results.
4. Check the power supply voltage 115V/230V switch.

Losing the System's Setup Configuration

1. Make sure that you are using a high quality power supply. A poor quality power supply may cause the system to lose the CMOS setup information. Refer to Section 1-6 for details on recommended power supplies.
2. The battery on your motherboard may be old. Check to verify that it still supplies ~3VDC. If it does not, replace it with a new one.

3. If the above steps do not fix the Setup Configuration problem, contact your vendor for repairs.

3-2 Technical Support Procedures

Before contacting Technical Support, please take the following steps. Also, note that as a motherboard manufacturer, Super Micro does not sell directly to end-users, so it is best to first check with your distributor or reseller for troubleshooting services. They should know of any possible problem(s) with the specific system configuration that was sold to you.

1. Please go through the 'Troubleshooting Procedures' and 'Frequently Asked Question' (FAQ) sections in this chapter or see the FAQs on our web site (<http://www.supermicro.com/support/faqs/>) before contacting Technical Support.



Note: *Not all BIOS can be flashed; it depends on the modifications to the boot block code.*

2. BIOS upgrades can be downloaded from our web site at (<http://www.supermicro.com/support/bios/>) If you still cannot resolve the problem, include the following information when contacting Supermicro for technical support:
 - Motherboard model and PCB revision number
 - BIOS release date/version (this can be seen on the initial display when your system first boots up).
 - System configuration
 - An example of a Technical Support form is on our web site at (<http://www.supermicro.com/support/contact.cfm>).
 - Distributors: For immediate assistance, please have your account number ready when placing a call to our technical support department. We can be reached by e-mail at support@supermicro.com, by phone at:(408) 503-8000, option 2, or by fax at (408)503-8019.

3-3 Frequently Asked Questions

Question: What type of memory does my motherboard support?

Answer: The X7SBL-LN1/LN2 supports **unbuffered**, ECC/Non-ECC DDR2 667/800 MHz memory modules. See Section 2-4 for details on installing memory.

Question: Why does Microsoft Windows XP (SP2) and Windows Vista show less memory than what is physically installed?

Answer: Microsoft implemented a design change in Windows XP with Service Pack 2 (SP2) and Windows Vista. This change is specific to the Physical Address Extension (PAE) mode behavior which improves driver compatibility. For more information, please read the following article at Microsoft's Knowledge Base website at: <http://support.microsoft.com/kb/888137>.

Question: How do I update my BIOS?

Answer: It is recommended that you **do not** upgrade your BIOS if you are not experiencing any problems with your system. Updated BIOS files are located on our web site at <http://www.supermicro.com/support/bios/>. Please check our BIOS warning message and the information on how to update your BIOS on our web site. Select your motherboard model and download the BIOS (.rom) file to your computer. Also, check the current BIOS revision and make sure that it is newer than your BIOS before downloading. You may choose the zip file or the .exe file. If you choose the zipped BIOS file, please unzip the BIOS file onto a bootable device or a USB pen/thumb drive. To flash the BIOS, run the batch file named "flash.bat" with the new BIOS .rom file from your bootable device or USB pen/thumb drive. Use the following format:

```
F:\> flash xxxxxxxx.rom <Enter>
```



Note: Be sure to insert a space immediately after "flash" and use only the file named "flash.bat" to update the BIOS.

When completed, your system will automatically reboot. If you choose the .exe file, please run the .exe file under Windows to create the BIOS flash floppy disk. Insert the floppy disk into the system you wish to flash the BIOS. Then, boot the system to the floppy disk. The BIOS utility will automatically flash the BIOS without any prompts. Please note that this process may take a few minutes to complete. Do not be concerned if the screen is paused for a few minutes.



Warning: Do not shut down or reset the system while updating the BIOS to prevent possible system boot failure!

When the BIOS flashing screen is completed, the system will reboot and will show "Press F1 or F2". At this point, you will need to load the BIOS defaults.

Press <F1> to go to the BIOS setup screen, and press <F9> to load the default settings. Next, press <F10> to save and exit. The system will then reboot.



Note: The SPI BIOS chip installed on this motherboard is not removable. To repair or replace a damaged BIOS chip, please send your motherboard to RMA at Supermicro for service.

Question: What's on the CD that came with my motherboard?

Answer: The supplied compact disc has quite a few drivers and programs that will greatly enhance your system. We recommend that you review the CD and install the applications you need. Applications on the CD include chipset drivers for Windows and security and audio drivers.

Question: After I have installed 4 pieces of 1GB Memory, why does the BIOS only detect about 3.145 GB of memory during POST?

Answer: Because the chipset does not support memory remapping, and PCI-E memory requires a great deal of memory, so there is a memory hole located around the 4GB memory address.

3-4 Returning Merchandise for Service

A receipt or copy of your invoice marked with the date of purchase is required before any warranty service will be rendered. You can obtain service by calling your vendor for a Returned Merchandise Authorization (RMA) number. When returning to the manufacturer, the RMA number should be prominently displayed on the outside of the shipping carton, and mailed prepaid or hand-carried. Shipping and handling charges will be applied for all orders that must be mailed when service is complete.

This warranty only covers normal consumer use and does not cover damages incurred in shipping or from failure due to the alteration, misuse, abuse or improper maintenance of products. During the warranty period, contact your distributor first for any product problems.

Notes

Chapter 4

BIOS

4-1 Introduction

This chapter describes the Phoenix BIOS™ Setup utility for the X7SBL-LN1/LN2. The Phoenix ROM BIOS is stored in a flash chip and can be easily upgraded using a floppy disk-based program.



Note: Due to periodic changes to the BIOS, some settings may have been added or deleted and might not yet be recorded in this manual. Please refer to the Manual Download area of the Super Micro web site <<http://www.supermicro.com>> for any changes to the BIOS not reflected in this manual.

System BIOS

The BIOS is the Basic Input Output System used in all IBM® PC, XT™, AT®, and PS/2® compatible computers. The Phoenix BIOS stores the system parameters, types of disk drives, video displays, etc. in the CMOS. The CMOS memory requires very little electrical power. When the computer is turned off, a backup battery provides power to the CMOS logic, enabling it to retain system parameters. Each time the computer is powered on, the computer is configured with the values stored in the CMOS logic by the system BIOS, which gains control at boot-up.

How To Change the Configuration Data

The CMOS information that determines the system parameters may be changed by entering the BIOS Setup utility. This Setup utility can be accessed by pressing the <Delete> key at the appropriate time during system boot. (See below.)

Starting the Setup Utility

Normally, the only visible POST (Power On Self Test) routine is the memory test. As the memory is being tested, press the <Delete> key to enter the main menu of the BIOS Setup utility. From the main menu, you can access the other setup screens, such as the Security and Power menus. Beginning with Section 4-3, detailed descriptions are given for each parameter setting in the Setup utility.



Warning: Do not shut down or reset the system while updating the BIOS to prevent possible boot failure.

4-2 Running Setup

**Default settings are in bold text unless otherwise noted.*

The BIOS setup options described in this section are selected by choosing the appropriate text from the main BIOS Setup screen. All displayed text is described in this section, although the screen display is often all you need to understand how to set the options (see next page).

When you first power on the computer, the Phoenix BIOS™ is immediately activated.

While the BIOS is in control, the Setup program can be activated in one of two ways:

1. By pressing <Delete> immediately after turning the system on, or
2. When the message shown below appears briefly at the bottom of the screen during the POST (Power On Self-Test), press the <Delete> key to activate the main Setup menu.

Press the <Delete> key to enter Setup

4-3 Main BIOS Setup

All main Setup options are described in this section. The main BIOS Setup screen is displayed below.

Use the Up/Down arrow keys to move among the different settings in each menu. Use the Left/Right arrow keys to change the options for each setting.

Press the <Esc> key to exit the CMOS Setup Menu. The next section describes in detail how to navigate through the menus.

Items that use submenus are indicated with the ► icon. With the item highlighted, press the <Enter> key to access the submenu.

Main BIOS Setup Menu

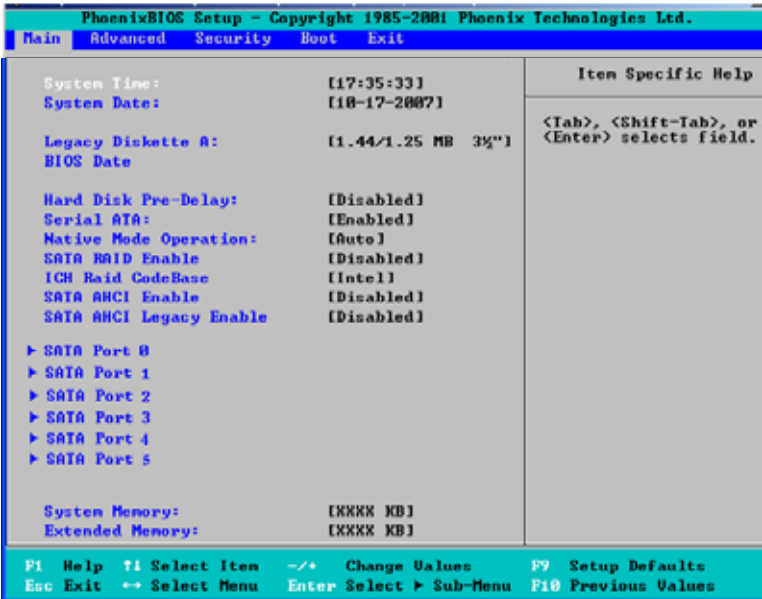

► Main Setup Features

System Time

To set the system date and time, key in the correct information in the appropriate fields. Then press the <Enter> key to save the data.

System Date

Using the arrow keys, highlight the month, day and year fields, and enter the correct data. Press the <Enter> key to save the data.

Legacy Diskette A

This setting allows the user to set the type of floppy disk drive installed as diskette A. The options are Disabled, 360Kb 5.25 in, 1.2MB 5.25 in, 720Kb 3.5 in, **1.44/1.25MB** 3.5 in and 2.88MB 3.5 in.

BIOS Date

The item displays the date that the BIOS was built.

BIOS Revision

The item displays the BIOS revision number.

Hard Disk Pre-Delay

This setting allows the user to add a delay prior to the first access of a hard disk by the BIOS. The delay ensures that the hard disk has time to initialize before power up. The options are **Disabled**, 3 Seconds, 6 Seconds, 9 Seconds, 12 Seconds, 15 Seconds, 21 Seconds and 30 Seconds

Serial ATA

This setting allows you to enable or disable the function of the Serial ATA. The options are Disabled and **Enabled**.

Native Mode Operation

Select Serial ATA for SATA or select Auto (Native Mode) for ATA. The options are: Serial ATA and **Auto**.

SATA RAID Enable

This setting allows you to enable or disable the SATA RAID functionality. The options are **Disabled** and Enabled.

ICH RAID CobeBase

Select Intel to enable the Intel SATA RAID firmware. Select Adaptec to use the Adaptec HostRAID firmware. The options are **Intel** and Adaptec.

SATA AHCI Enable

Enhanced AHCI: WinXP-SPI + IAA driver supports AHCI mode. The options are **Disabled** and Enabled.

SATA AHCI Legacy Enable

This setting allows you to disable SATA ports 5 and 6 while in this mode. The options are **Disabled** and Enabled.

► IDE Channel 0 Master/Slave/SATA Port2/SATA Port3

These settings allow you to set the parameters of slots indicated above. Hit <Enter> to activate the following sub-menu screen for detailed options of these items. Set the correct configurations accordingly. The items included in the sub-menu are the following:

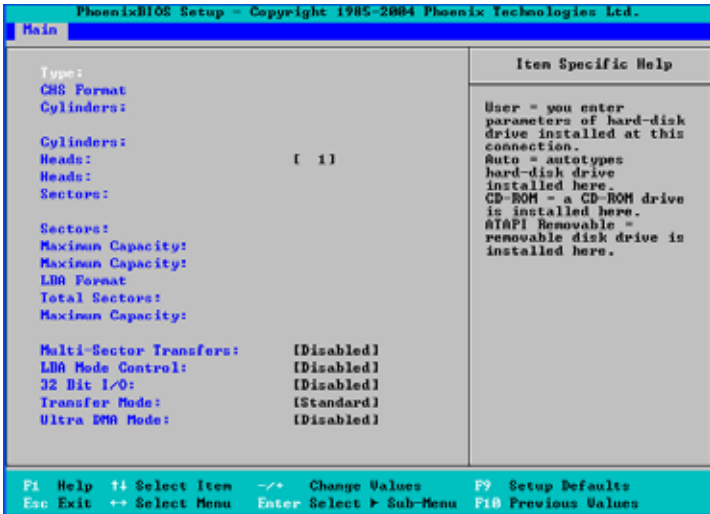

Type

This option allows you to select the type of storage or ROM drive. **Auto** allows the BIOS to automatically determine the drive's type/capacity (number of heads, etc.). User allows you to enter the parameters for the storage device installed on this particular port. For hard drives, enter a number between 1 to 39 to select a predetermined HDD type. Select CDROM if a CDROM drive is installed. Select ATAPI if a removable disk drive is installed.



Note: Select User for any device or legacy device that is not supported or automatically detected under Auto. This enables you to manually enter parameters for devices that are not otherwise available in the BIOS' drive table.

CHS Format

The following items will be displayed by the BIOS:

TYPE: This item displays the type of IDE or SATA Device.

Cylinders: This item indicates the status of Cylinders.

Headers: This item indicates the number of headers.

Sectors: This item displays the number of sectors.

Maximum Capacity: This item displays the maximum storage capacity of the system.

LBA Format

The following items will be displayed by the BIOS:

Total Sectors: This item displays the number of total sectors available in the LBA Format.

Maximum Capacity: This item displays the maximum capacity in the LBA Format.

Multi-Sector Transfers

This item allows you to specify the number of sectors per block to be used in the multi-sector transfer. The options are **Disabled**, 4 Sectors, 8 Sectors, and 16 Sectors.

LBA Mode Control

This item allows you to use logical block addressing in place of cylinders, heads, and sectors. The options are Enabled and **Disabled**.

32 Bit I/O

This option allows you to enable or disable the function of a 32-bit data transfer. The options are Enabled and **Disabled**.

Transfer Mode

This option allows you to set the transfer mode. The options are **Standard**, Fast PIO1, Fast PIO2, Fast PIO3, Fast PIO4, FPIO3/DMA1 and FPIO4/DMA2.

Ultra DMA Mode

This option allows you to select the Ultra DMA Mode. The options are **Disabled and Enabled**.

Installed Memory

This display informs you how much total memory installed in the system is detected by the BIOS.

System Memory

This display informs you how much of the installed memory is available to the system.

4-4 Advanced Setup

Choose Advanced from the Phoenix BIOS Setup Utility main menu with the arrow keys. You should see the following display. The items with a triangle beside them have sub- menus that can be accessed by highlighting the item and pressing <Enter>.

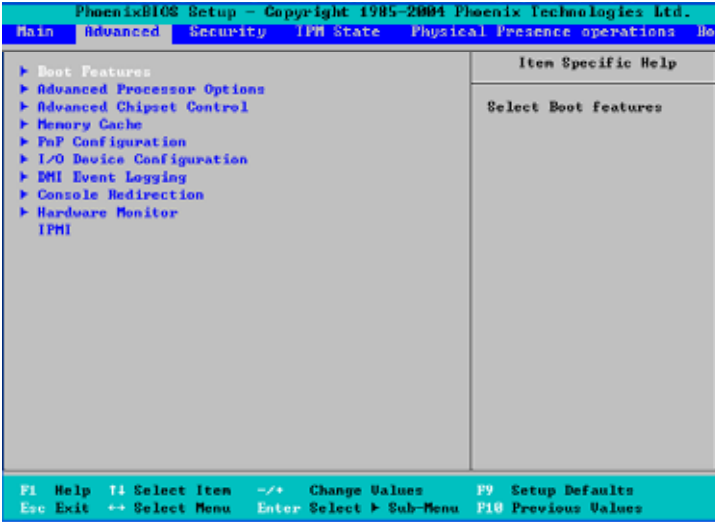

▶ Boot Features

Quiet Boot

This setting allows you to **Enable** or Disable the graphic logo screen display during bootup.

QuickBoot Mode

If enabled, this feature will speed up the POST (Power On Self Test) routine by skipping certain tests after the computer is turned on. The settings are **Enabled** and Disabled. If Disabled, the POST routine will run at normal speed.

POST Errors

Use the setting to Pause and Display SETUP entry or resume boot prompt if error occurs on boot disabled. The options are **Enabled** and Disabled.

ACPI Mode

Use the setting to determine whether you want to use the ACPI (Advanced Configuration and Power Interface) power management on your system. The options are **Yes** and No.

Power Button Behavior

If set to **Instant-Off**, the system will power on or power off immediately as soon as you hit the power button. The options are **Instant-Off** and 4-second Override.

Resume On Modem Ring

Select On to “wake your system up” when an incoming call is received by your modem. The options are On and **Off**.

Resume On PME#

Select On to “wake your system up” from the PME#. The options are **On** and Off.

PS2 Keyboard (KB)/Mouse Wake Up

Select Enable to “wake your system up” from the S1/S3/S4/S5 state. The options are Enabled and **Disabled**.

USB Wake Up

This setting allows you to wake up the system from S3/S4 state. Make sure to set the proper jumper first for USB wake up. The options are Enabled and **Disabled**.

Power Loss Control

This setting allows you to choose how the system will react when power returns after an unexpected loss of power. The options are Stay Off, Power On, and **Last State**.

Watch Dog

Select Enabled to automatically reset the system if the system is not active for more than 4 minutes. The options are Enabled and **Disabled**.

Summary Screen

This setting allows you to **Enable** or Disable the summary screen which displays the system configuration during bootup.

► Advanced Processor Options

Access the submenu to make changes to the following settings.

CPU Speed

This is a display that indicates the speed of the installed processor.

Frequency Ratio (*Available when supported by the CPU.)

The feature allows you to set the internal frequency multiplier for the CPU. The options are: **Default**, x6, x7, x8, x9, x10 and x11.

Frequency High Ratio (*Available when supported by the CPU.)

The feature allows you to set the high ratio internal frequency multiplier for the Intel SpeedStep CPUs. The settings are: **Default**, [X6] to [X11], [X12] to [X27].



Note: If a wrong ratio that is not supported by the CPU is selected, the system may hang. If this happens, clear the CMOS to recover the system.

Hyperthreading (Available when supported by the CPU)

Set to Enabled to use the Hyperthreading Technology, which will result in increased CPU performance. The options are **Enabled** and Disabled.

Core-Multi-Processing (Available when supported by the CPU.)

Set to Enabled to use a processor's Second Core and beyond. (Please refer to Intel's web site for more information.) The options are Disabled and **Enabled**.

Intel Enhanced Debug (Recommended for maintenance)

This feature allows an operating system level debug of issues that may be processor related. The options are **Enabled** and Disabled.

Machine Checking (Available when supported by the CPU.)

Set to Enabled to activate the function of Machine Checking and allow the CPU to detect and report hardware (machine) errors via a set of model-specific registers (MSRs). The options are Disabled and **Enabled**.

Compatible FPU Code (Available when supported by the CPU.)

Set to Enabled to keep the content of the last instruction Operating Code (OP-Code) in the floating point (FP) state. The options are **Disabled** and Enabled.

L3 Cache (Available when supported by the CPU.)

This feature allows you to select this very fast memory that filters information between the processor and the slower RAM. The options are **Enabled** or Disabled.

Thermal Management 2 (Available when supported by the CPU.)

Set to **Enabled** to use Thermal Management 2 (TM2,) which will lower the CPU voltage and frequency when the CPU temperature reaches a predefined over-heat threshold. Set to Disabled to use Thermal Manager 1 (TM1), allowing CPU clocking to be regulated via the CPU Internal Clock modulation when the CPU temperature reaches the overheat threshold.

Adjacent Cache Line Prefetch (*Available when supported by the CPU.)

The CPU fetches the cache line for 64 bytes if this option is set to Disabled. The CPU fetches both cache lines for 128 bytes as comprised if Enabled. The options are Disabled and **Enabled**.

Set Maximum Ext. CPUID=3

When set to Enabled, the Maximum Extended CPUID will be set to 3. The options are **Disabled** and Enabled.

Echo TPR

Set to **Enabled** to prevent xTPR messages from being sent to the system. The options are Disabled and **Enabled**. (For debug only)

C1 Enhanced Mode (Available when supported by the CPU.)

Set to Enabled to enable the Enhanced Halt State to lower CPU voltage/frequency to prevent overheat. The options are Enabled and **Disabled**.



Note: Please refer to Intel's web site for detailed information.

Intel® Virtualization Technology (Available when supported by the CPU.)

Select Enabled to use the feature of Virtualization Technology to allow one platform to run multiple operating systems and applications in independent partitions, creating multiple virtual systems in one computer. The options are Enabled and **Disabled**.



Note: If there is any change to this setting, you will need to power off and re-start the system for the change to take effect.) Please refer to Intel's web site for detailed information.

No Execute Mode Memory Protection (Available when supported by the CPU and the OS.)

Set to Enabled to enable Execute Disable Bit and allow the processor to classify areas in memory where an application code can execute and where it cannot, and thus preventing a worm or a virus from inserting and creating a flood of codes to overwhelm the processor or damage the system during an attack.



Note 1: This feature is available when your OS and your CPU support the function of Execute Disable Bit. The options are Disabled and **Enabled**.

Note 2: For more information regarding the hardware/software support for this function, please refer to Intel's and Microsoft's web sites.

Enhanced Intel Speed Step (Available when supported by the CPU.)

Select Enabled to use the Enhanced Intel SpeedStep Technology and allows the system to automatically adjust the processor voltage and core frequency in an effort to reduce power consumption and heat dissipation. The options are Enabled (-C States, GV1/GV3 are enabled), **GV1/GV3 Only** (C States: Disabled), C-States Only (-G1/G3: Disabled), and Disabled (-C States, GV1/GV3 are disabled). Please refer to Intel's web site for detailed information.

► Advanced Chipset Control

Access the submenu to make changes to the following settings.



Warning: Take caution when changing the Advanced settings. An incorrect setting, a very high DRAM frequency or an incorrect DRAM timing may result in system instability. When this occurs, revert to the default setting.

Clock Spectrum Feature

If Enabled, BIOS will monitor the level of Electromagnetic Interference caused by the components and will attempt to decrease the interference whenever needed. The options are **Disabled** and Enabled.

Memory Remapping

This feature allows the bios reserve memories to remap the memory above the 4GB to 5GB area when using 4GB of memory. The settings are **Enabled** and **Disabled**.

Enable VT-D

Select **Enable** to use the functionality of VT-D. The options are **Enabled** and **Disabled**.

High Precision Event Timer

Select **Yes** to activate this feature which is capable of producing periodic interrupts at a much higher frequency than a Real-time Clock (RTC) can in synchronizing multimedia streams, providing smooth playback and reducing the dependency on other timestamp calculation devices, such as an X86 RDTSC Instruction embedded in a CPU. The High Precision Event Timer is used to replace the 8254 Programmable Interval Timer. The options are **Yes** and **No**.

Route Port 80h Cycles to

This feature allows the user to decide which bus to send debug information to. The options are **PCI** and **LPC**.

USB Host Controller

This feature enables or disables the USB Host Controller. The options are **Enabled** and **Disabled**.

EHCI Controller

This feature enables the onboard Enhanced Host Controller Interface. The options are **Enabled** and **Disabled**.

Legacy USB Support

This feature enables support for legacy Universal Serial Bus. The options are **Enabled** and **Disabled**.

► Memory Cache

Cache System BIOS Area

This setting allows you to designate a reserve area in the system memory to be used as a System BIOS buffer and allow BIOS to write (cache) data into this reserved memory area. Select **Write Protect** to enable this function, and this area will be reserved for BIOS ROM access only. Select Uncached to disable this function and make this area available for other devices.

Cache Video BIOS Area

This setting allows you to designate a reserve area in the system memory to be used as a Video BIOS buffer and allow BIOS to write (cache) data into this reserved memory area. Select **Write Protect** to enable the function and this area will be reserved for Video BIOS ROM access only. Select Uncached to disable this function and make this area available for other devices.

Cache Base 0-512K

If enabled, this feature will allow the data stored in the base memory area: block 0-512K to be cached (written) into a buffer, a storage area in the Static DROM (SDROM) or to be written into L1, L2 cache inside the CPU to speed up CPU operations. Select Uncached to disable this function. Select Write Through to allow data to be cached into the buffer and written into the system memory at the same time. Select Write Protect to prevent data from being written into the base memory area of Block 0-512K. Select Write Back to allow the CPU to write data back directly from the buffer without writing data to the System Memory for fast CPU data processing and operation. The options are Uncached, Write Through, Write Protect, and **Write Back**.

Cache Base 512K-640K

If enabled, this feature will allow the data stored in the memory area: 512K-640K to be cached (written) into a buffer, a storage area in the Static DROM (SDROM) or written into L1, L2, L3 cache inside the CPU to speed up CPU operations. Select Uncached to disable this function. Select Write Through to allow data to be cached into the buffer and written into the system memory at the same time. Select Write Protect to prevent data from being written into the base memory area of Block 512K-640K. Select **Write Back** to allow the CPU

to write data back directly from the buffer without writing data to the System Memory for fast CPU.

Cache Extended Memory

If enabled, this feature will allow the data stored in the extended memory area to be cached (written) into a buffer, a storage area in the Static DROM (SDROM) or written into L1, L2, L3 cache inside the CPU to speed up CPU operations. Select Uncached to disable this function. Select Write Through to allow data to be cached into the buffer and written into the system memory at the same time. Select Write Protect to prevent data from being written into the extended memory area above 1 MB. Select Write Back to allow the CPU to write data back directly from the buffer without writing data to the System Memory for fast CPU data processing and operation. The options are Uncached, Write Through, Write Protect, and **Write Back**.

► PNP Configuration

Access the submenu to make changes to the following settings for PNP (Play & Plug) devices.

► PCI32 Slot#1 - PCI32 Slot#2

Access the submenu for each of the settings above to make changes to the following:

Option ROM Scan

When enabled, this setting will initialize the device expansion ROM. The options are **Enabled** and Disabled.

Enable Master

This setting allows you to enable the selected device as the PCI bus master. The options are Enabled and **Disabled**.

Latency Timer

This setting allows you to set the clock rate for Bus Master. A high-priority, high-throughput device may benefit from a greater clock rate. The options are **Default**,

0020h, 0040h, 0060h, 0080h, 00A0h, 00C0h, and 00E0h. For Unix, Novell and other Operating Systems, please select the option: other. If a drive fails after the installation of a new software, you might want to change this setting and try again. A different OS requires a different Bus Master clock rate.

► Slot 3 PCI-Exp x4

Access the submenu for each of the settings above to make changes to the following:

Option ROM Scan

When enabled, this setting will initialize the device expansion ROM. The options are **Enabled** and Disabled.

Enable Master

This setting allows you to enable the selected device as the PCI bus master. The options are **Enabled** and Disabled.

Latency Timer

This setting allows you to set the clock rate for Bus Master. A high-priority, high-throughput device may benefit from a greater clock rate. The options are **Default**, 0020h, 0040h, 0060h, 0080h, 00A0h, 00C0h, and 00E0h. For Unix, Novelle and other Operating Systems, please select the option: other. If a drive fails after the installation of a new software, you might want to change this setting and try again. A different OS requires a different Bus Master clock rate.

► Slot 4 PCI-Exp x8

Access the submenu for each of the settings above to make changes to the following:

Option ROM Scan

When enabled, this setting will initialize the device expansion ROM. The options are **Enabled** and Disabled.

Enable Master

This setting allows you to enable the selected device as the PCI bus master. The options are **Enabled** and Disabled.

Latency Timer

This setting allows you to set the clock rate for Bus Master. A high-priority, high-throughput device may benefit from a greater clock rate. The options are **Default**, 0020h, 0040h, 0060h, 0080h, 00A0h, 00C0h, and 00E0h. For Unix, Novelle and other Operating Systems, please select the option: other. If a drive fails after the installation of a new software, you might want to change this setting and try again. A different OS requires a different Bus Master clock rate.

► Onboard LAN 1 and Onboard LAN 2

Option ROM Scan

When enabled, this setting will initialize the device expansion ROM. The options are Enabled and **Disabled**. This will allow the system to boot from the LAN.

Enable Master

This setting allows you to enable the selected device as the PCI bus master. The options are Enabled and **Disabled**.

Latency Timer

This setting allows you to set the clock rate for Bus Master. A high-priority, high-throughput device may benefit from a greater clock rate. The options are **Default**, 0020h, 0040h, 0060h, 0080h, 00A0h, 00C0h, and 00E0h. For Unix, Novelle and other Operating Systems, please select the option: other. If a drive fails after the installation of a new software, you might want to change this setting and try again. A different OS requires a different Bus Master clock rate.

► I/O Device Configuration

Access the submenu to make changes to the following settings.

KBC Clock Input

This setting allows you to select the clock frequency for the Keyboard Controller. The options are 6MHz, 8MHz, **12MHz**, and 16MHz.

Serial Port A

This setting allows you to decide how the system controls Serial Port A. The options are **Enabled** (user defined) and Disabled.

Base I/O Address

This setting allows you to select the base I/O address for Serial Port A. The options are **3F8**, 2F8, 3E8, and 2E8.

Interrupt

This setting allows you to select the IRQ (interrupt request) for Serial Port A. The options are IRQ3 and **IRQ4**.

Serial Port B

This setting allows you to decide how the system controls Serial Port B. The options are **Enabled** (user defined), Disabled, Auto (BIOS controlled) and OS Controlled.

Mode

This setting allows you to set the type of device that will be connected to Serial Port B. The options are **Normal** and IR (for an infrared device) and ASK-IR.

Base I/O Address

This setting allows you to select the base I/O address for Serial Port B. The options are 3F8, **2F8**, 3E8 and 2E8.

Interrupt

This setting allows you to select the IRQ (interrupt request) for Serial Port B. The options are **IRQ3** and IRQ4.

Floppy Disk Controller

This setting allows you to assign control of the floppy disk controller. The options are **Enabled** (user defined), Disabled, and Auto (BIOS and OS controlled).

► DMI Event Logging

Event Log Validity

This displays the validity of the DMI event log.

Event Log Capacity

This displays the space available in the DMI event log. Full indicates the DMI log has no more space available to store DMI events.

View DMI Event Log

This setting allows the user to view the events in the DMI log.

Event Logging

Select **Enable** to log DMI events. The options are **Enabled** and Disabled.

Mark DMI Events as Read

This setting allows you to mark DMI events as read.

Clear all DMI Event Logs

Setting this option to Yes will clear the DMI event log before rebooting. The options are Yes and **No**.

► Console Redirection

Access the submenu to make changes to the following settings:

COM Port Address

This setting will allow you to specify which COM port to direct the remote console to: Onboard COM A or Onboard COM B. The options are **Disabled**, COM A and COM B.

Baud Rate

This setting will enable you to set the BAUD rate for the console redirection. The options are 300,1200, 2400, 9600, **19.2 K**, 38.4K, 57.6K, and 115.2K.

Console Type

This setting will enable you to set the console redirection type. The options are VT100, VT100 (8bit), PC ANSI (7bit), **PC ANSI**, VT100+, VT-UTF8 and ASCII.

Flow Control

This setting enables you to select the flow control option for the console. The options are: None, XON/XOFF, and **CTS/RTS**.

Console Connection

This setting allows you to decide how the console redirection is to be connected. The options are **Direct** or Via Modem.

Continue CR after Post

This setting allows you to decide if you would like to continue with the console redirection after the POST routine. The options are On and **Off**.

► Hardware Monitoring

This feature allows the BIOS to automatically monitor the following components and display the temperature of each component as detected. Highlight this and hit <Enter> to see monitor data for the following items:

CPU Overheat Alarm

This option allows the user to select the CPU Overheat Alarm setting which determines when the CPU OH alarm will be activated to provide warning of possible CPU overheat.

Warning: Any temperature that exceeds the CPU threshold temperature predefined by the CPU manufacturer may result in CPU overheat or system instability. When the CPU temperature reaches this predefined threshold, the CPU and system cooling fans will run at full speed.

The options are:

The **Default Alarm Setting**: Select this setting if you want the CPU overheat alarm (including the LED and the buzzer) to be triggered when the CPU temperature reaches about 5°C above the threshold temperature as predefined by the CPU manufacturer to give the CPU and system fans additional time needed for CPU and system cooling.

The **Early Alarm Setting**: Select this setting if you want the CPU overheat alarm (including the LED and the buzzer) to be triggered as soon as the CPU temperature reaches the CPU overheat threshold as predefined by the CPU manufacturer. (See the notes on P. 4-23 for more information.)

CPU Temperature

The CPU Temperature feature will display the CPU temperature status as detected by the BIOS:

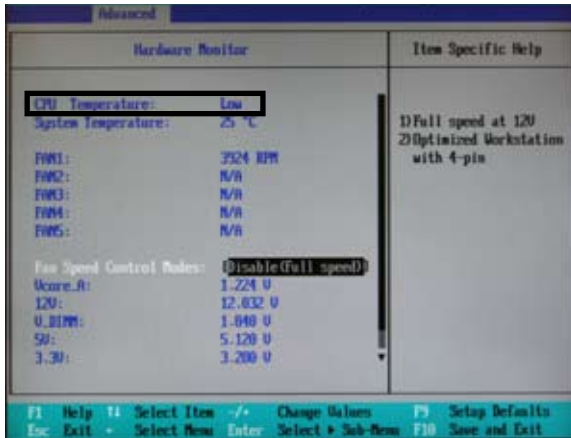

Low – This level is considered as the 'normal' operating state. The CPU temperature is well below the CPU 'Temperature Tolerance'. The motherboard fans and CPU will run normally as configured in the BIOS (Fan Speed Control).

User intervention: No action required.

Medium – The processor is running warmer. This is a 'precautionary' level and generally means that there may be factors contributing to this condition, but the CPU is still within its normal operating state and below the CPU 'Temperature Tolerance'. The motherboard fans and CPU will run normally as configured in the BIOS. The fans may adjust to a faster speed depending on the Fan Speed Control settings.

User intervention: No action is required. However, consider checking the CPU fans and the chassis ventilation for blockage.

High – The processor is running hot. This is a 'caution' level since the CPU's 'Temperature Tolerance' has been reached (or has been exceeded) and may activate an overheat alarm:

The Default Alarm – the Overheat LED and system buzzer will activate if the High condition continues for some time after it is reached. The CPU fan will run at full

speed to bring the CPU temperature down. If the CPU temperature still increases even with the CPU fan running at full speed, the system buzzer will activate and the Overheat LED will turn on.

The Early Alarm – the Overheat LED and system buzzer will be activated exactly when the High level is reached. The CPU fan will run at full speed to bring the CPU temperature down.

Note: In both the alarms above, please take immediate action as shown below. See CPU Overheat Alarm to modify the above alarm settings.

User intervention: If the system buzzer and Overheat LED has activated, take action immediately by checking the system fans, chassis ventilation and room temperature to correct any problems. Note: the system may shut down if it continues for a long period to prevent damage to the CPU.



Notes: The CPU thermal technology that reports absolute temperatures (Celsius/Fahrenheit) has been upgraded to a more advanced feature by Intel in its newer processors. The basic concept is that each CPU is embedded by a unique temperature information that the motherboard can read. This 'Temperature Threshold' or 'Temperature Tolerance' has been assigned at the factory and is the baseline by which the motherboard takes action during different CPU temperature conditions (i.e., by increasing CPU Fan speed, triggering the Overheat Alarm, etc). Since CPUs can have different 'Temperature Tolerances', the installed CPU can now send its 'Temperature Tolerance' to the motherboard resulting in better CPU thermal management.

Supermicro has leveraged this feature by assigning a temperature status to certain thermal conditions in the processor (Low, Medium and High). This makes it easier for the user to understand the CPU's temperature status, rather than by just simply seeing a temperature reading (i.e., 25°C).

The information provided above is for your reference only. For more information on thermal management, please refer to Intel's Web site at www.Intel.com.

System Temperature

This item displays the absolute temperature as detected by the BIOS.

Fan1 - Fan 5

The BIOS will automatically display the status of the fan as specified.

Fan Speed Control Modes

This feature allows you to decide how the system controls the speeds of the onboard fans. The CPU temperature and the fan speed are correlative. When the CPU on-die temperature increases, the fan speed will also increase, and vice versa. If the option is set to "4-pin", the fan speed will be controlled by Pulse Width Modulation (PWM). Select "Workstation" if your system is used as a Workstation. Select "Disable" to disable the fan speed control function to allow the onboard fans to constantly run at full speed (12V). The Options are: **1. Disable** and **2. 3-pin (server) 3-pin (workstation), 4-pin (server) and 4-pin (workstation)**. Do not select 4-pin settings if you have a mix of 3-pin and 4-pin fans.

Voltage Monitoring

The following items will be monitored and displayed:

Vcore A, MCH Core, -12V, V-DIMM, 3.3V, +12V, 5V Standby, 5VDD, PVTT, Vbatt



Note: In the Windows OS environment, the Supero Doctor III settings take precedence over the BIOS settings. When first installed, Supero Doctor III adopts the temperature threshold settings previously set in the BIOS. Any subsequent changes to these thresholds must be made within Supero Doctor, since the SD III settings override the BIOS settings. For the Windows OS to adopt the BIOS temperature threshold settings, please change the SDIII settings to be the same as those set in the BIOS.

4-5 Security Settings

Choose Security from the Phoenix BIOS Setup Utility main menu with the arrow keys. You should see the following display. Security setting options are displayed by highlighting the setting using the arrow keys and pressing <Enter>. All Security BIOS settings are described in this section.

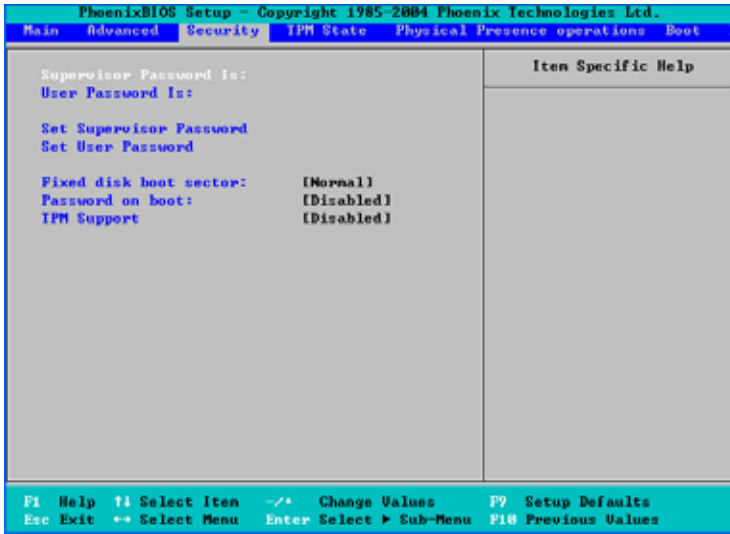

Supervisor Password Is:

This item indicates if a supervisor password has been entered for the system. Clear means such a password has not been used and Set means a supervisor password has been entered for the system.

User Password Is:

This item indicates if a user password has been entered for the system. Clear means such a password has not been used and Set means a user password has been entered for the system.

Set Supervisor Password

When the item Set Supervisor Password is highlighted, hit the <Enter> key. When prompted, type the Supervisor's password in the dialogue box to set or to change supervisor's password, which allows access to the BIOS.

Set User Password

When the item Set User Password is highlighted, hit the <Enter> key. When prompted, type the user's password in the dialogue box to set or to change the user's password, which allows access to the system at boot-up.

Fixed Disk Boot Sector

Select **Normal** to enable the function of Write-Protect to protect the boot sector on the hard drives against viruses.

Password on Boot

When this feature is set to Enabled, a password is required for a user to enter the system at bootup. The options are Enabled (password required) and **Disabled** (password not required).

4-6 Boot Settings

Choose Boot from the Phoenix BIOS Setup Utility main menu with the arrow keys. You should see the following display. See details on how to change the order and specs of boot devices in the Item Specific Help window. All Boot BIOS settings are described in this section.



Boot Priority Order/Excluded from Boot Orders

The devices included in the boot list section (above) are bootable devices listed in the sequence of boot order as specified. The boot functions for the devices included in the candidate list (above) are currently disabled. Use a <+> key or a <-> key to move the device up or down. Use the <f> key or the <r> key to specify the type of an USB device, either fixed or removable. You can select one item from the boot list and hit the <x> key to remove it from the list of bootable devices (to make its resource available for other bootable devices). Subsequently, you can select an item from the candidate list and hit the <x> key to remove it from the candidate list and put it in the boot list. This item will then become a bootable device. See details on how to change the priority of boot order of devices in the Item Specific Help window.

4-7 Exit

Choose Exit from the Phoenix BIOS Setup Utility main menu with the arrow keys. You should see the following display. All Exit BIOS settings are described in this section.

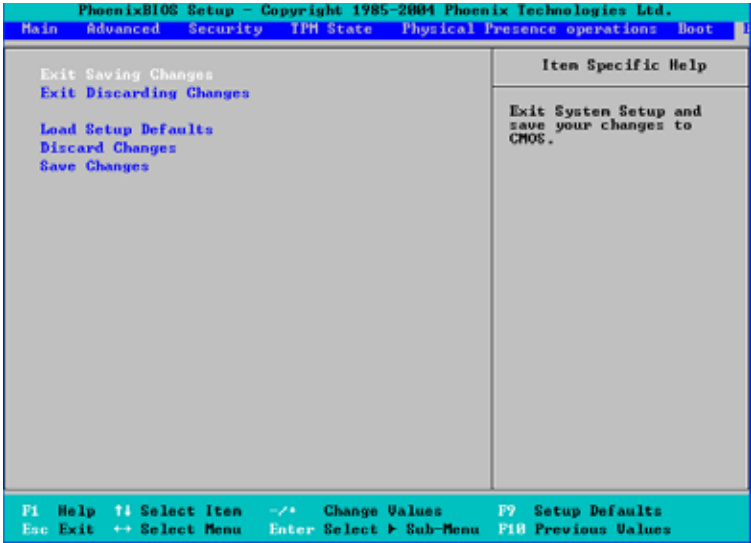

Exit Saving Changes

Highlight this item and hit <Enter> to exit the BIOS Setup utility while saving any changes you may have made.

Exit Discarding Changes

Highlight this item and hit <Enter> to exit the BIOS Setup utility without saving any changes you may have made.

Load Setup Defaults

Highlight this item and hit <Enter> to load the default settings for all items in the BIOS Setup. These are the safest settings to use.

Discard Changes

Highlight this item and hit <Enter> to discard (cancel) any changes you made. You will remain in the Setup utility.

Save Changes

Highlight this item and hit <Enter> to save any changes you made. You will remain in the Setup utility.

Appendix A

BIOS Error Beep Codes

This section lists POST (Power On Self Test) error beep codes for the Phoenix BIOS. POST error beep codes are divided into two categories: recoverable and terminal. This section lists Beep Codes for recoverable POST errors.

Recoverable POST Error Beep Codes

When a recoverable type of error occurs during POST, BIOS will display a POST code that describes the problem. BIOS may also issue one of the following beep codes:

- 1 long and two short beeps - video configuration error
- 1 repetitive long beep - no memory detected
- 1 continuous beep (with front panel OH LED on) - system overheat

Notes

Appendix B

Installing the Windows OS

After all hardware components have been installed, you must first configure Intel South Bridge RAID Settings before you install the Windows OS and other software drivers. To configure RAID settings, please refer to RAID Configuration User Guides posted on our website at www.supermicro.com/support/manuals.

B-1 Installing the Windows XP/2003 OS for Systems with RAID Functions

1. Insert Microsoft's Windows XP/2003 Setup CD in the CD Driver, and the system will start booting up from CD.
2. Press the <F6> key when the message-" Press F6 if you need to install a third party SCSI or RAID driver" displays.
3. When the Windows XP/2003 Setup screen appears, press "S" to specify additional device(s).
4. Insert the driver diskette-"Intel AA RAID XP/2003 Driver for ICH9R" into Drive A: and press the <Enter> key.
5. Choose the Intel(R) ICH9R *SATA RAID Controller* from the list indicated in the XP/2003 Setup Screen, and press the <Enter> key.
6. Press the <Enter> key to continue the installation process. (If you need to specify any additional devices to be installed, do it at this time.) Once all devices are specified, press the <Enter> key to continue with the installation.
7. From the Windows XP/2003 Setup screen, press the <Enter> key. The XP/2003 Setup will automatically load all device files and then, continue the Windows XP/2003 installation.
8. After the Windows XP/2003 OS Installation is completed, the system will automatically reboot.

B-2 Installing the Windows XP/2003 OS for Systems without RAID Functions

1. Insert Microsoft's Windows XP/2003 Setup CD in the CD Driver, and the system will start booting up from CD.
2. Continue with the OS installation. The Windows OS Setup screen will display.
3. From the Windows XP/2003 Setup screen, press the <Enter> key. The XP/2003 Setup will automatically load all device files and then continue with the Windows XP/2003 installation.
4. After the Windows XP/2003 OS Installation is completed, the system will automatically reboot.
5. Insert the Supermicro Setup CD that came with your motherboard into the CD Drive during system boot, and the main screen will display.

Appendix C

Installing Other Software Programs and Drivers

C-1 Installing Drivers other than the Adaptec Embedded Serial ATA RAID Controller Driver

After you've installed the Windows Operating System, a screen as shown below will appear. You are ready to install software programs and drivers that have not yet been installed. To install these software programs and drivers, click the icons to the right of these items.

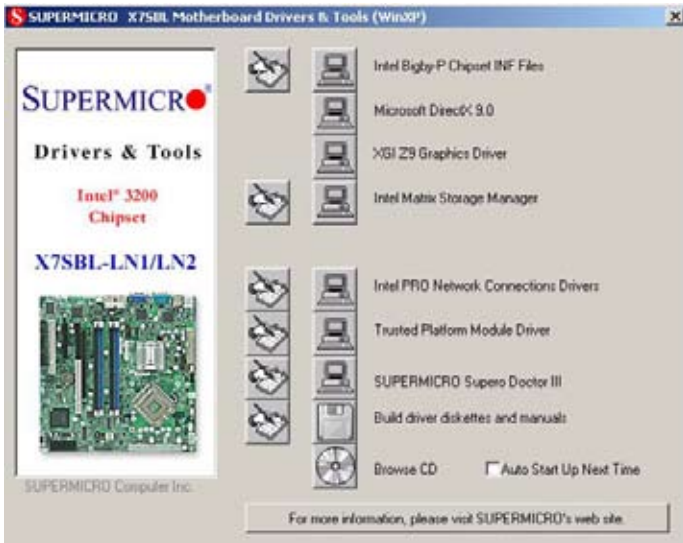

Driver/Tool Installation Display Screen



Note: Click the icons showing a hand writing on the paper to view the readme files for each item. Click on a computer icon to the right of an item to install an item (from top to the bottom) one at a time. **After installing each item, you must re-boot the system before proceeding with the next item on the list.** The bottom icon with a CD on it allows you to view the entire contents of the CD.

C-2 Configuring Supero Doctor III

The Supero Doctor III program is a Web-base management tool that supports remote management capability. It includes Remote and Local Management tools. The local management is called the SD III Client. The Supero Doctor III program included on the CDROM that came with your motherboard allows you to monitor the environment and operations of your system. Supero Doctor III displays crucial system information such as CPU temperature, system voltages and fan status. See the Figure below for a display of the Supero Doctor III interface.



Note: 1 The default user name and password are ADMIN.

Note 2: In the Windows OS environment, the Supero Doctor III settings take precedence over the BIOS settings. When first installed, Supero Doctor III adopts the temperature threshold settings previously set in BIOS. Any subsequent changes to these thresholds must be made within Supero Doctor, since the SD III settings override the BIOS settings. For the Windows OS to adopt the BIOS temperature threshold settings, please change the SDIII settings to be the same as those set in BIOS.

Supero Doctor III Interface Display Screen-I (Health Information)



Supero Doctor III Interface Display Screen-II (Remote Control)

Note: SD III Software Revision 1.0 can be downloaded from our website at: ftp://ftp.supermicro.com/utility/Supero_Doctor_III/. You can also download SDIII User's Guide at: <http://www.supermicro.com/PRODUCT/Manuals/SDIII/UserGuide.pdf>. For Linux, we will still recommend that you use Supero Doctor II.

Notes

Disclaimer

The products sold by Supermicro are not intended for and will not be used in life support systems, medical equipment, nuclear facilities or systems, aircraft, aircraft devices, aircraft/emergency communication devices or other critical systems whose failure to perform be reasonably expected to result in significant injury or loss of life or catastrophic property damage. Accordingly, Supermicro disclaims any and all liability, and should buyer use or sell such products for use in such ultra-hazardous applications, it does so entirely at its own risk. Furthermore, buyer agrees to fully indemnify, defend and hold Supermicro harmless for and against any and all claims, demands, actions, litigation, and proceedings of any kind arising out of or related to such ultra-hazardous use or sale.