



Declaration of Conformity

According to 47 CFR, Parts 2 and 15 of the FCC Rules

The following designated product:

EQUIPMENT: MAINBOARD
MODEL NO.: 9BIF3/9LIF3

is a Class B digital device that complies with 47 CFR Parts 2 and 15 of the FCC Rules. Operation is subject to the following two conditions:

1. This device may not cause harmful interference.
2. This device must accept any interference received, including interference that may cause undesired operation.

This declaration is given to the manufacturer:

CHAINTECH - EXCEL COMPUTER U.S., INC.
4427 Enterprise ST. Fremont, CA 94538, U.S.A.

<http://www.chaintech-excel.com>

Chaintech President: Simon Ho

Signature:

A handwritten signature in black ink, appearing to be 'Simon Ho', written over a horizontal line.



Federal Communications Commission Statement

This device complies with FCC Rules Part 15. Operation is subject to the following two conditions:

- ♦ This device may not cause harmful interference
- ♦ This device must accept any interference received, including interference that may cause undesired operation.

This equipment has been tested and found to comply with the limits for a Class B digital device, pursuant to Part 15 of the FCC Rules. These limits are designed to provide reasonable protection against harmful interference in a residential installation. This equipment generates, uses and can radiate radio frequency energy. If this equipment is not installed and used in accordance with the manufacturer's instructions, it may cause harmful interference to radio communications. However, there is no guarantee that interference will not occur in a particular installation. If this equipment does cause harmful interference to radio or television reception, which can be determined by turning the equipment off and on, the user is encouraged to try to correct the interference by one or more of the following measures:

- ♦ Reorient or relocate the receiving antenna.
- ♦ Increase the separation between the equipment and receiver.
- ♦ Connect the equipment to an outlet on a circuit different from that to which the receiver is connected.
- ♦ Consult the dealer or an experienced radio/TV technician for help.

The use of shielded cables for connection of the monitor to the graphics card is required to assure compliance with FCC regulations. Changes or modifications to this unit not expressly approved by the party responsible for compliance could void the user's authority to operate this equipment.

Canadian Department of Communications Statement

This digital apparatus does not exceed the Class B limits for audio noise emissions from digital apparatuses set out in the Radio Interference Regulations of the Canadian Department of Communications.

Manufacturer's Disclaimer Statement

The information in this document is subject to change without notice and does not represent a commitment on the part of the vendor. No warranty or representation, either expressed or implied, is made with respect to the quality, accuracy or fitness for any particular purpose of this document. The manufacturer reserves the right to make changes to the content of this document and/or the products associated with it at any time without obligation to notify any person or organization of such changes. In no event will the manufacturer be liable for direct, indirect, special, incidental or consequential damages arising out of the use or inability to use this product or documentation, even if advised of the possibility of such damages. This document contains materials protected by copyright. All rights are reserved. No part of this manual may be reproduced or transmitted in any form, by any means or for any purpose without expressed written consent of its authors. Product names appearing in this document are mentioned for identification purposes only. All trademarks, product names or brand names appearing in this document are registered property of their respective owners.

Printed in Taiwan

May 2002

100% POST-CONSUMER
RECYCLED PAPER 

Table of Contents

Chapter 1 Introduction	1
1-1 Product Specifications	1
1-2 Package Contents	2
1-3 Mainboard Layout	3
1-4 Connector and Jumper Reference Chart	4
Chapter 2 Hardware Setup	5
2-1 Installing a CPU in a Socket 478	5
2-2 Setting Your CPU's Parameters.....	5
2-3 Connector and Jumper Settings	6
2-4 Main Memory Configuration	10
Chapter 3 Phoenix-AwardBIOS Setup Program	11
3-1 Standard CMOS Features	12
3-2 Advanced BIOS Features	13
3-3 Advanced Chipset Features.....	16
3-4 Integrated Peripherals	17
3-5 Power Management Setup	19
3-6 PnP/PCI Configuration	22
3-7 PC Health Status.....	23
3-8 Frequency/Voltage Control	23
3-9 Load Fail-Safe Defaults	24
3-10 Load Optimized Defaults.....	24
3-11 Supervisor Password & User Password Setting	25
3-12 Save and Exit Setup	25
3-13 Exit Without Saving.....	25
Feature Explanations	
Software Power-off Control	6
Over-ride Power Button.....	7
Blinking LED in Suspend Mode	6
Power On By Modem	6/21
Power On By Alarm	21
Poly-fuse Over Current Protection	6
Wake Up On LAN	9
Appendix	
Thiz Linux Desktop 6.0	26

Chapter 1

Introduction

1-1 Product Specifications

❑ Processor

- Supports Intel Pentium 4 Socket 478 processors
- Support system bus at 400/533MHz (Brookdale-G)
- Support system bus at 400MHz (Brookdale-GL)

❑ Chipset

- Intel optional Brookdale-G or Brookdale-GL + ICH4 chipset

❑ DRAM Memory

- Two 184-pin DDR DIMM sockets support up to 2 GB
- Supports PC-1600/2100 DDR SDRAM Modules

❑ Expansion Slots

- One AGP slot for 4XAGP at 1.5v (v2.0 compliant) or optional LTI2-845G adapter supports DVI and NTSC/PAL TV system (Brookdale-G)
- One AGP slot exclusively for optional LTI2-845G adapter supports DVI and NTSC/PAL TV system only (Brookdale-GL)
- Three 32-bit PCI slots (Rev 2.2 compliant)
- One CNR slot for modem, audio and LAN riser



Brookdale-G chip support only 1.5v AGP electricals. VGA card using 3.3v or other voltages may result in system boot up failure, malfunction, etc.

❑ Boot-Block Flash ROM

- Phoenix-Award BIOS, supports PnP, APM, DMI, ACPI & Multi-device booting features i.e. floppy, LS120, CD/DVD-ROM, HDD(IDE, SCSI), ZIP-ATAPI etc.

❑ Embedded Ultra DMA-100 PCI IDE controller

- Supports two IDE ports up to 4 ATAPI devices
- Supports up to PIO Mode 4 up to 16.6MBps, Multi Mode 4 up to 66MBps and Multi Word Mode 5 up to 100MBps with bus mastering
- Bus Mastering software drivers for common multi-task operating systems

❑ On-board Super I/O Controller

- ITE 8712 LPC with system monitoring hardware
- Two UARTs support two serial ports and IR function for HPSIR and ASKIR
- One parallel supports SPP/ECP/EPP
- One floppy disk drive connector supports up to 2.88MB
- Integrated smart card reader function and interface

❑ Embedded System Monitor Hardware

- 8 external voltage inputs
- 1 temperature sensor with thermistor for CPU and System

❑ **Embedded USB Controller**

- Support up to 6 USB ports (EHCI/UHCI v1.1 compliant)
- Optional USB riser with additional 2 USB ports

📄 **The official USB 2.0 driver for Windows XP is available on-line at Windows Update website at <http://windowsupdate.microsoft.com/>**

❑ **Ethernet 10/100 Controller**

- On board LAN VIA VT6105LOM support 10/100Mbps Ethernet operation

❑ **Double Stack Back-Panel I/O Connectors**

- PS/2 Mini-DIN keyboard and mouse port
- Two USB port and One RJ45 connector
- One 9-pin D-Sub male Serial port
- One 15-pin D-Sub femaleVGA port
- One 25-pin D-Sub female Printer port
- Audio Line-in/out and Mic-in jacks
- One 15-pin D-Sub female Game/MIDI port

❑ **On board video Sub-system**

- Integrated 2D/3D graphics accelerator
- Full frame DVD audio and video playback
- Shared system memory use Intel D.V.M. technology

❑ **Audio Subsystem via AC-link**

- AC"97 V2.1 compliant CODEC with integrated SRC

1-2 Package Contents

This product comes with the following components:

- ❑ One mainboard
 - ❑ One 40-pin (80-conductor) UDMA-100 IDE connector ribbon cable (Figure 1-1)
* **Color coded cable:** Blue to mainboard, Gray to Master and Black to slave
 - ❑ One 34-pin floppy disk drive ribbon cable (Figure 1-2)
 - ❑ One 9-pin serial port ribbon cable (optional)
 - ❑ One User's Manual
 - ❑ **One CD-ROM that includes**
 - Award DMI Utility for DOS
 - Audio and VGA drivers and utilities
 - Intel Chipset Software installation utility
 - Optional **Value Pack 2002** software pack including Norton AntiVirus, Adobe ActiveShare, Acrobat Reader, Acrobat eBook Reader, Imagemore and AutoSave.
- 📄 **See the Readme.txt file in the CD-ROM's root directory for installation instructions of all driver and software utilities.**

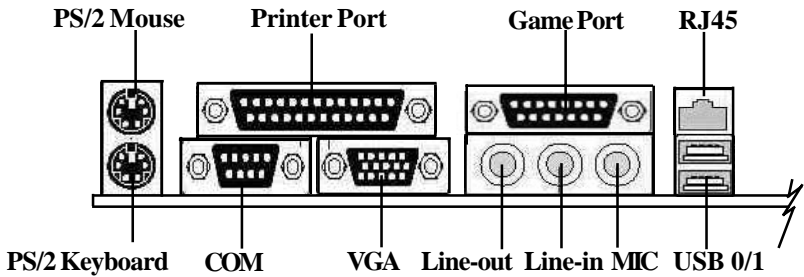
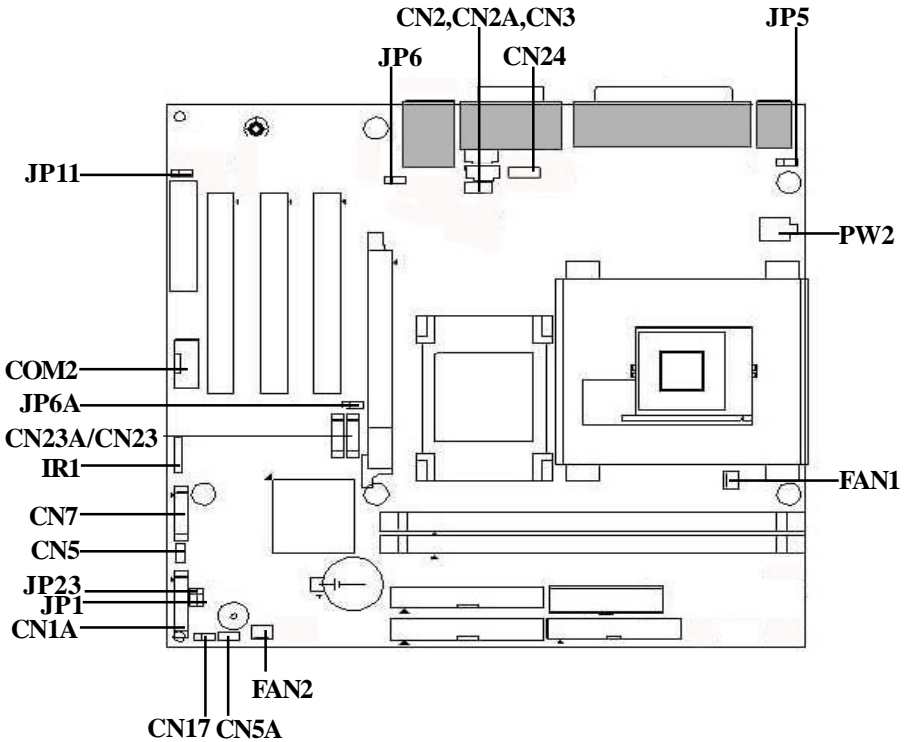

Figure 1-1 UDMA 100 IDE cable



Figure 1-2 Standard Floppy cable

1-3 Mainboard Layout



1-4 Connector and Jumper Reference Chart

Jumper & Connector No.	Function	Page
JP1	Clear CMOS Data Jumper	8
JP5	Power On By Keyboard	8
JP6/JP6A	Power On By USB 0/1 and 2/3	8
JP11	On board LAN	8
CN1A	Over ride Power Button Connector	7
	Power Indicator LED Connector	
	Green Button/LED Connector	
	System Reset Switch Connector	
	Speaker Connector	
	IDE Activity LED Connector	
CN2/CN2A	CD-ROM Audio in Connector	8
CN3	Auxiliary Audio-in Connector	8
CN5	WOL (Wake-on-LAN) Connector	9
CN5A	WOM (Wake-on-Modem) Connector	9
CN7	Smart Card Reader Connector	9
CN17	Blue LED Connector	9
USB1/CN23/CN23A	USB 0/1 Ports, USB 2/3 and 4/5 Connectors	9
CN24	Front Panel Audio Connector	9
IR1	IR Connector	10
FAN1/FAN2	CPU/System Cooling Fan Connector	10
COM2	COM 2 Header	10
PW1/PW2	ATX/ATX12V Power Supply Connector	6

Chapter 2

Hardware Setup

If your mainboard has already been installed in your computer you may still need to refer to this chapter if you plan to upgrade your system's hardware.



Be sure to disconnect the power cable from the power source before performing any work on your mainboard, i. e. installing a CPU, memory module, changing a jumper setting, etc. Not doing so may result in electrical shock!

2-1 Installing a CPU in a Socket 478

The Intel Socket 478, designed for the Pentium 4 processor, has been incorporated as a standard mainboard specification. To insert your CPU into Socket 478 please do the following:

1. Locate a small dot marked on the top surface of the CPU close to one of its corners. The same corner will also be cut off, leaving a noticeable notch in the CPU's corner. These markings indicate Pin 1 of the CPU.
2. Pull up the lever of Socket 478 so that it is perpendicular with the surface of the mainboard. Gently insert the CPU with Pin 1 at the same corner of Socket 478 that contains the end of the lever. Allow the weight of the CPU to push itself into place. Do not apply extra pressure as doing so may result in damaging your CPU. Snap the lever back into place.



Installing a standard Intel specified heat sink with cooling fan is necessary for proper heat dissipation from your CPU. Failing to install these items may result in overheating and possible burn-out of your CPU.

2-2 Setting Your CPU's Parameters

This mainboard uses a new user friendly technology that enables the user to setup a mainboard's CPU parameters through an easy to use BIOS setup procedure. It is no longer necessary to make many jumper settings as on conventional mainboards.

After installing all your hardware into your PC system, you can manually configure your CPU clock ratio and CPU clock according to your processor's specifications. By turning on your system's power. Enter the CMOS Setup Utility by pressing the Delete key when your BIOS identification screen appears, then go to the Frequency/Voltage Control option and select your CPU clock ratio and CPU clock speed (See Chapter 3).



You do not need to make voltage settings because this mainboard will automatically set your CPU voltage.

2-3 Connector and Jumper Settings

Connectors are used to link the system board with other parts of the system, including the power supply, the keyboard, and the various controllers of the system case.



The power supply connector is the last connection to be made while installing a mainboard. Before connecting the power supply, please make sure it is not connected to the power source.

ATX/ATX12V Power Supply Connector (PW1/PW2)

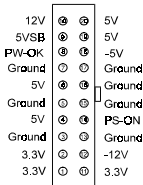

PW 1

Pin	Signal	Wire
1	COM	BLK
2	COM	BLK
3	+12VDC	YEL
4	+12VDC	YEL

PW 2

The ATX power supply provides a single 20-pin connector interface which incorporates standard +/-5V, +/-12V, optional 3.3V and Soft-power signals. The Soft-power signal, a 5V trickle supply is continuously supplied when AC power is available. When the system is in the Soft-Off mode, this trickle supply maintains the system in its minimum power state.

The ATX12V power supply has a new +12 V (4-pin) auxiliary power connector. To enable the delivery of more +12 VDC current to the motherboard.

Software Power-Off Control

This mainboard can be powered down using the Windows 9x Software Power-Off function. To power down your computer, click the START button on the Windows 9x task bar. Select "Shut Down The Computer" and the system turns off. The message "It is now safe to turn off your computer" will not be shown when using this function.

Power-On By Modem

While in Soft-off state, if an external modem ring-up signal occurs, the system wakes up and can be remotely accessed. You may enable this function in BIOS's Power Management Setup menu. (See Chapter 3)

Blinking LED in Suspend Mode

While in Suspend mode, the LED light on the front panel of your computer will flash. Suspend mode is entered by pressing the Override Power Button, pushing the Green button on your ATX case, or enabling the Power Management and Suspend Mode options in BIOS's Power Management menu. (See Chapter 3)

Poly-fuse Over Current Protection

The poly-fuse protects the system from dangerous voltages the system might be exposed to via the keyboard or USB connectors. In case of such exposure, the poly-fuse will immediately be disconnected from the circuit, just like a normal fuse. After being disconnected for a certain period of time, the poly-fuse will return to its normal state, after which the keyboard or USB can function properly again.

Front Panel Connector Set (CN1A) A through F

A. Over-ride Power Button Connector

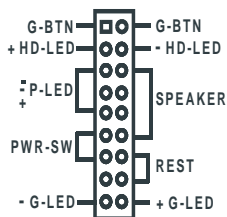

The power button on the ATX chassis can be used as a normal power switch as well as a device to activate Advanced Power Management Suspend mode. This mode is used for saving electricity when the computer is not in use for long periods of time. The Soft-off by PWRBTN function in BIOS's Power Management Setup menu must be set to "Delay 4 Sec." to activate this function.

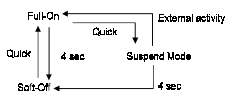

Over-ride Power Button

When the Soft-off by PWRBTN function is enabled, pushing the power button rapidly will switch the system to Suspend mode. Any occurrence of external activities such as pressing a key on the keyboard or moving the mouse will bring the system back to Full-On. Pushing the button while in Full-On mode for more than 4 seconds will switch the system completely off. See Over-ride Power Button Operation diagram.

B. Power Indicator LED Connector

The power indicator LED shows the system's power status. It is important to pay attention to the correct cables and pin orientation (i.e., not to reverse the order of these two connectors.)

C. Green Button/LED Connector

Some ATX cases provide a Green button switch which is used to put the system in Suspend mode. In Suspend mode, the power supply to the system is reduced to a trickle, the CPU clock is stopped, and the CPU core is in its minimum power state. The system is woken up whenever the keyboard or mouse is touched. The system resumes in different ways as defined by Power Management Setup screen in BIOS.

D. System Reset Switch Connector

This connector should be connected to the reset switch on the front panel of the system case. The reset switch allows you to restart the system without turning the power off.

E. Speaker Connector

This 4-pin connector connects to the case-mounted speaker

F. IDE Activity LED Connector

The IDE activity LED lights up whenever the system reads/writes to the IDE devices.

Clear CMOS Data (JP1)

Pin	Definition
1~2	Normal (default)
2~3	Clear CMOS Data

To clear the contents of the CMOS, please follow the steps below.

1. Disconnect the system power supply from the power source.
2. Set the jumper cap at location 2~3 for 5 seconds, then set it back to the default position.
3. Connect the system's power and then start the system.
4. Enter BIOS's CMOS Setup Utility and choose Load Setup Defaults. Type Y and press enter.
5. Set the system configuration in the Standard CMOS Setup menu.

Power On By Keyboard (JP5)

Pin	Definition
1~2	Disable (default)
2~3	Enable

This board is able to be turned on by the PS/2 keyboard (hot key). To use this function, select a hot key of your choice at the PS2KB Wakeup option under Wake Up Events in the BIOS's Power On Management screen. You must also set this jumper's cap to pins 2-3 to use this function.

Power On By USB 0/1 and 2/3 (JP6/JP6A)

Pin	Definition
1~2	Disable (default)
2~3	Enable

This board is able to be turned on by a USB keyboard hot key or a USB mouse click. To use this function, select a hot key of your choice at the USB Kb Power Wake-Up From S3 option under Wake Up Events in the BIOS's Power On Management screen. You must also set both jumper's cap to pins 2-3 to use this function.

On board LAN (JP11)

Pin	Definition
1~2	Enable
2~3	Disable (default)

This function allows you to enable or disable the on board LAN. You must set the jumper cap to pins 1-2 to enable or set pins 2-3 to disable this function.

CD-ROM Audio-in Connector (CN2/CN2A)



Use the audio cable enclosed with your CD-ROM disk drive to connect the CD-ROM to your mainboard. This will enable your CD-ROM's audio function.

Auxiliary Audio-in Connector (CN3)



This connector is for use with a secondary CD-ROM, DVD-ROM or CDR/CDRW disk drive.

WOL (Wake-on-LAN) Connector (CN5)

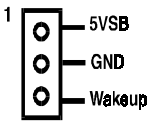

Enable the Wake Up On LAN selection in BIOS's Power Management Menu to use this function. The capability to remotely manage PCs on a network is a significant factor in reducing administrative and ownership costs. Magic Packet technology is designed to give WOL capability to the LAN controller. This header is used to connect an add-in NIC (Network Interface Card) which gives WOL capability to the mainboard.

WOM (Wake-on-Modem) Connector (CN5A)

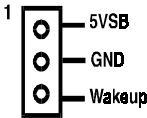

Enable the Wake Up On Modem selection in BIOS's Power Management Menu to use this function. This header is used to connect an add-in modem card which gives WOM capability to the mainboard.

Smart Card Reader Connector (CN7)

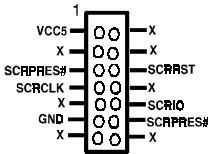

This connector must be connected to an optional Smart card reader.

Blue LED Connector(CN17)

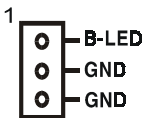

This feature work entirely the same as the power indicator LED, both shows the system's power status. The only difference is that this one is blue while the other is red LED.

USB 0/1 Ports, USB 2/3 and 4/5 Connectors (USB1/CN23/CN23A)

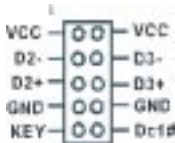

If you want to use a USB Keyboard, you must enable the USB keyboard support function in BIOS's Integrated Peripherals menu (See Section 3-4). This board contains a USB Host controller and includes a root hub with two USB 0/1 ports and two connectors for optional USB Adaptor (USB 2/3 and 4/5).

Front Panel Audio Connector (CN24)

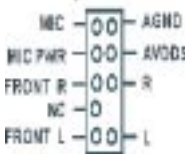

This connector give you the option of a front panel audio jack cable ext. to be plug into a special custom designed system case. Simply remove the two jumper caps at pin 5-6 and 9-10 then plug it into the (optional) cable ext. connector. Pin 5-6 and 9-10 are shorted (default) to enabled the back panel audio function.

IR Connector (IR1)

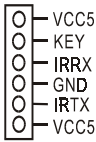

Select a COM2 Mode in BIOS's Integrated Peripherals menu the COM2 port to support IR functions. (See section 3-4)

CPU/System Cooling Fan Connectors (FAN1/FAN2)

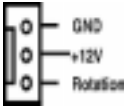

The board's management extension hardware is able to detect the CPU and system fan speed in rpm (revolutions per minute). The wiring and plug may vary depending on the manufacturer. On standard fans, the red is positive (+12V), the black is ground, and the yellow wire is the rotation signal.

COM 2 Header (COM2)

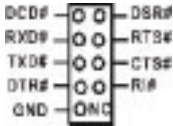

Use the serial port cable(optional) enclosed with your mainboard. Plug into the header and attached the other end with the bracket to the system case back panel.

2-4 Main Memory Configuration

The DDR SDRAM memory system consists two banks and can supports the memory size up to **1GB** per bank. If you only use one bank it does not matter which one you use and if you use two or more banks, it does not matter which bank you install first.

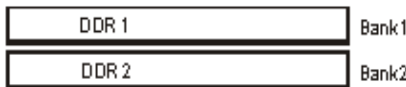

DDR SDRAM Specifications

FSB Frequency	Internal System Bus Freq.
100 MHz	200 MHz
133 MHz	266 MHz

DIMM type: 2.5V, Unbuffered non ECC DDR SDRAM supports 64/128 256/512-bit technology for x8 and x16 devices

Module size: Single/double-sided 64/128/256/512MB/1GB

Phoenix-AwardBIOS Setup Program

Phoenix-AwardBIOS ROM has a built-in setup program that allows users to modify the basic system configuration. This information is stored in CMOS RAM so that it can retain the setup information, even when the power is turned off. When you turn on or reboot the system, press the Delete key to enter the Phoenix-AwardBIOS setup program. The primary screen as shown in Figure 3-1 is a list of the menus and functions available in the setup program. Select the desired item and press enter to make changes. Operating commands are located at the bottom of this and all other BIOS screens. When a field is highlighted, on-line help information is displayed on the right side of the screen.

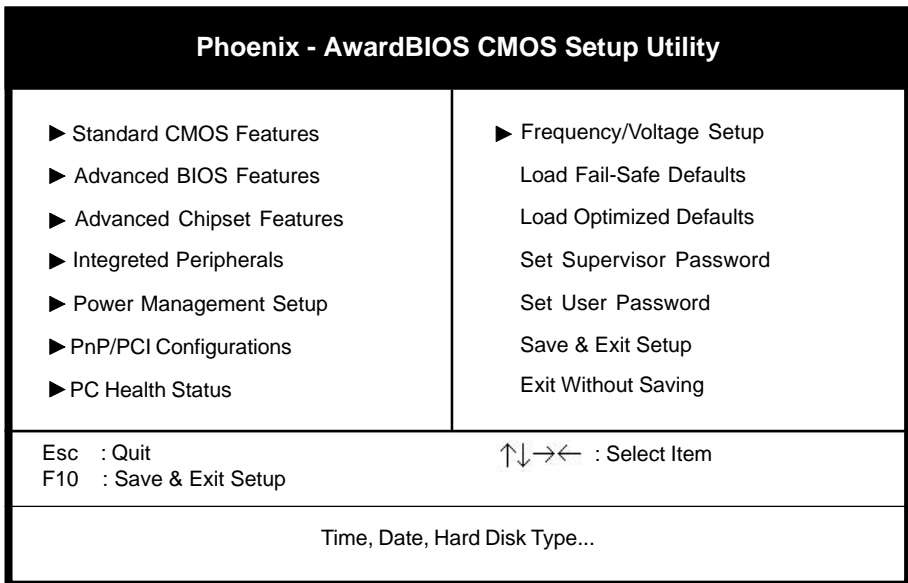

Figure 3-1 Setup Program Initial Screen

3-1 Standard CMOS Setup

The Standard CMOS Setup allows users to configure system components such as hard disk drive, floppy disk drive and video display as well as date, time and boot-up error signaling. This configuration menu should be changed when installing a mainboard for the first time, changing hardware in your system such as the HDD, FDD, video display, or when the CMOS data has been lost or contaminated. Choose the Standard CMOS Setup option from the CMOS Setup Utility menu (Figure 3-1) to display the following screen.

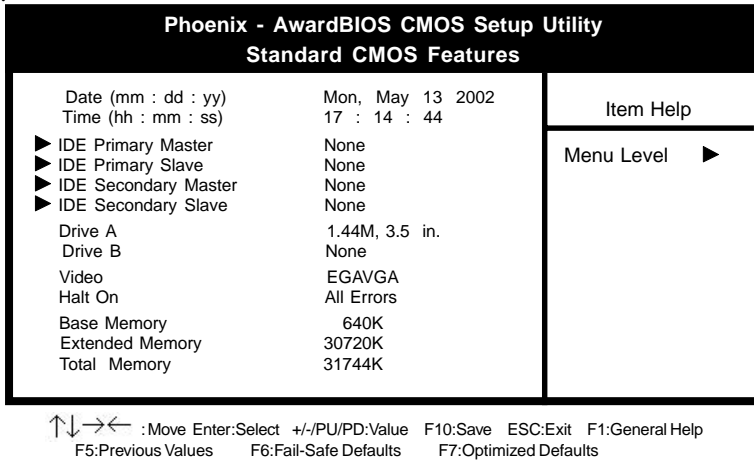

Figure 3-2 Standard CMOS Features Screen

Date/Time

Set the date and time. Do not skip this function as all of your timed events such as power management, saving files, etc. are based on this timer.

Hard Disk Setup (Primary/Secondary; Master/Slave)

This category identifies up to four IDE hard disk drives that have been installed in the computer. This section does not show information on other IDE devices such as CD-ROM drives or other hard drive types such as SCSI drives.

Floppy Disk Drives

Choose the memory capacity and disk size that corresponds with that of your floppy disk drive(s).

Video

Select the type of video adapter present in your system. You can ignore this setting if you are using a VGA monitor since VGA BIOS automatically configures this setting.

Halt

When the system is powered on, BIOS performs a series of diagnostic tests called POST (Power On Self Test). This function stops the computer if BIOS detects a hardware error. You can tell BIOS to halt on all errors, no errors, or not to halt on specific errors.

3-2 Advanced BIOS Features

By choosing the Advanced BIOS Features option from the Standard CMOS Features menu (Figure 3-1), the screen below is displayed. This sample screen is for reference use only.

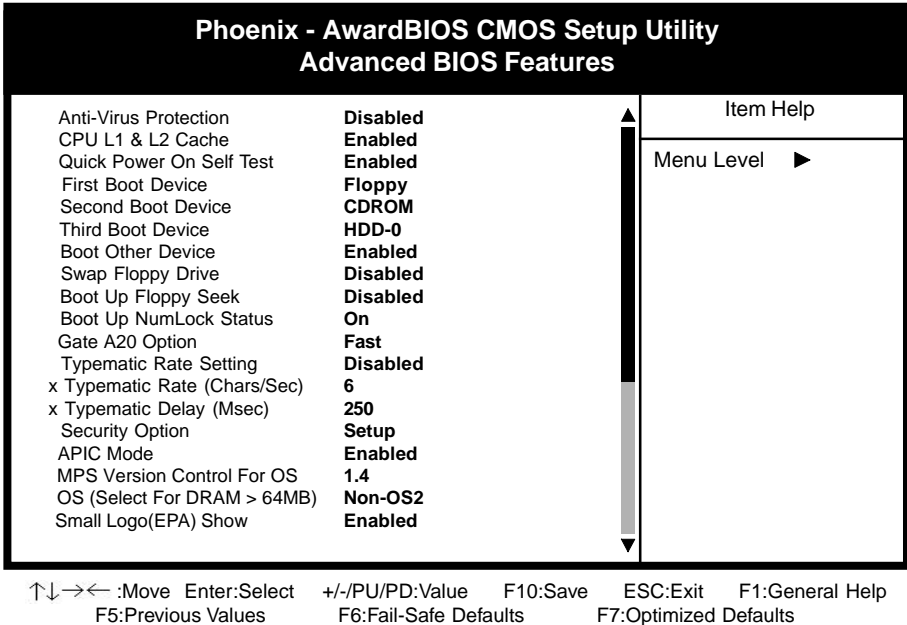

Figure 3-3 Advanced BIOS Features Screen

A. Anti-Virus Protection

Anti-Virus Protection is a code incorporated in the mainboard's BIOS firmware. During the boot-up sequence, BIOS loads before loading of the partition table or boot sector. Anti-Virus Protection loads with BIOS and is able to detect boot-up viruses before they have a chance to infect the hard drive. Anti-Virus Protection employs rule-based logic that doesn't look for specific viruses but rather detects patterns found in every virus, eliminating the need to perform periodical version updates after new viruses have been found.

B. CPU L1 and L2 Cache

Cache memory is much faster than conventional DRAM system memory. These fields allow you to enable or disable the CPUs Level 1 built-in cache and Level 2 external cache. Both settings are left enabled to significantly increase the performance of your computer.

C. Boot Up Features

After turning on the system, BIOS will perform a series of device initializations and diagnostic tests discussed below.

Quick Power On Self Test (POST)

Enable this function to reduce the amount of time required to run the POST (Power On Self Test). BIOS saves time by skipping some items during POST. It is recommended that you disable this setting. Discovering a problem during bootup is better than losing data during your work.

First/Second/Third/Boot Other Device

This option sets the sequence of drives BIOS attempts to boot from after POST completes. BIOS will search these drives for an operating system.

Swap Floppy Drive

Enabling this function will swap the floppy drive assignment so that drive A will function as drive B, and drive B will function as drive A. Note that the boot sequence assignment mentioned directly above does not include booting from floppy drive B. This function is useful if floppy drives B and A are of a different format and you want to boot from floppy drive B.

Boot up Floppy Seek

During POST, BIOS will determine if the installed floppy disk drive has 40 or 80 tracks. A 360K drive has 40 tracks and 720K, 1.2M and 1.44M drives have 80 tracks. All modern floppy disk drives have 80 tracks.

Boot Up NumLock Status

This function defines the keyboard's numberpad as number keys or arrow keys.

D. Gate A 20 Option

Gate A20 refers to the way the system addresses memory above 1 MB (extended memory). When set to Fast, the system chipset controls Gate A20. When set to Normal, a pin in the keyboard controller controls Gate A20. Setting Gate A20 to Fast improves system speed, particularly with OS/2 and Windows.

E. Keyboard Interface

Typematic Rate Setting

When enabled, you can set the following two typematic control items. When disabled, keystrokes are determined arbitrarily by the keyboard controller in your system.

Typematic Rate (Chars/Sec)

The typematic rate sets the rate at which characters on the screen repeat when a key is pressed and held down.

Typematic Delay (Msec)

The typematic delay sets how long after you press a key that a character begins repeating.

F. Security Option

The Supervisor and/or User Password functions shown in Figure 3-1 must be set to take advantage of this function. See Section 3-11 for password setting information. When the Security Option is set to System, a password must be entered to boot the system or enter the BIOS setup program. When the Security Option is set to Setup, a password is required to enter the BIOS setup program.

G. OS Select (For DRAM > 64MB)

If your system's DRAM is larger than 64MB and you are running OS/2, select OS/2 as the item value. Otherwise, set the item value to Non-OS/2 for all other operating systems.

3-3 Advance Chipset Features

By choosing the Advanced Chipset Features option from the Standard CMOS Features menu(Figure 3-1), the screen below is displayed.This sample screen is for reference use only.

Phoenix - AwardBIOS CMOS Setup Utility		Item Help
Advanced Chipset Features		Menu Level ▶
DRAM Timing Selectable	By SPD	
CAS Latency Time	1.5	
Active to Precharge Delay	7	
DRAM RAS# to CAS# Delay	3	
DRAM RAS# Precharge	3	
VGA Turbo Mode	Disabled	
Memory Frequency For	Auto	
System BIOS Cacheable	Enabled	
Video BIOS Cacheable	Disabled	
Delayed Transaction	Enabled	
Delay Prior to Thermal	16 Min	
AGP Aperture Size (MB)	64	
Flash BIOS Protection	Disabled	
** On-Chip VGA Setting **		
On-Chip VGA	Enabled	
On-Chip Frame Buffer Size	8MB	
Boot Display	Auto	

↑↓→← :Move Enter:Select +/-/PU/PD:Value F10:Save ESC:Exit F1:General Help
 F5:Previous Values F6:Fail-Safe Defaults F7:Optimized Defaults

Figure 3-4 Advanced Chipset Features Screen



All of the above settings have been determined by the mainboard manufacturer and should not be changed unless you are absolutely sure of what you are doing. Explanation of the DRAM timing and chipset features setup is lengthy, highly technical and beyond the scope of this manual.

A. AGP Aperture Size

Select the size of Accelerated Graphics Port (AGP) aperture. The aperture is a portion of the PCI memory address range dedicated for graphics memory address space. Host cycles that hit the aperture range are forwarded to the AGP without any translation.

B. Flash BIOS Protection

The mainboard manufacturer developed BIOS protection technology that protects the System BIOS from accidental corruption by unauthorized users or computer viruses. When enabled, the BIOS data cannot be changed when attempting to update BIOS with the the FLASH utility. When disabled, the BIOS data can be updated by using the FLASH utility.

3-4 Integrated Peripherals

This section provides information on setting peripheral devices. By choosing the Integrated Peripherals option from the Standard CMOS Features menu (Figure 3-1), the screen below is displayed. This sample screen is for reference use only.

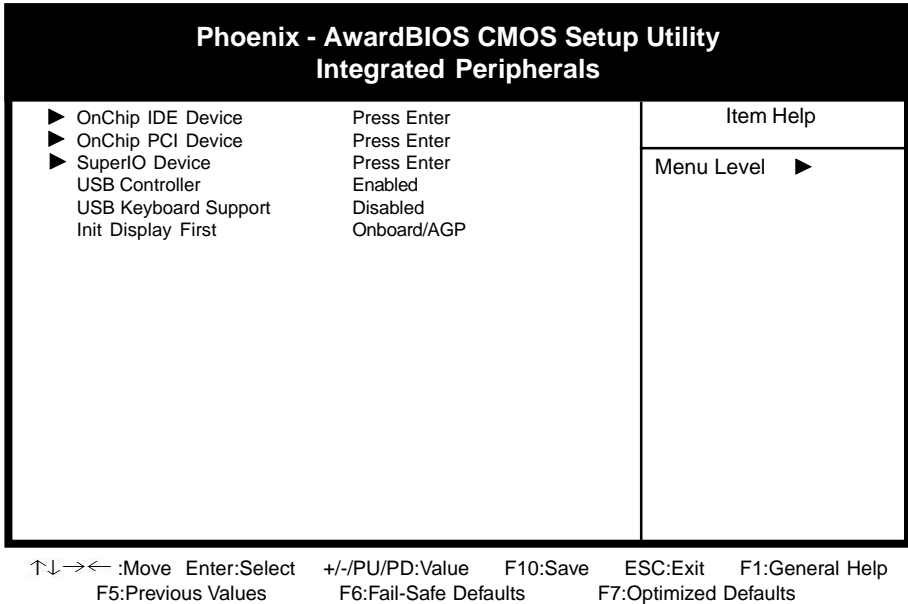

Figure 3-5 Integrated Peripherals Screen

A. OnChip IDE Device

On-chip Primary/Secondary PCIIDE

You can set this to disable the On-chip IDE controller if you are going to add a higher performance IDE board.

IDE Primary/Secondary Master/Slave PIO

The four IDE PIO (programmed Input/Output) fields let you set a PIO mode (0-4) for each IDE device that the internal PCI IDE interface supports. Modes 0 through 4 provide successively increased performance. In Auto mode, the system automatically determines the best mode for each device.

B. OnChip PCI Device

AC97 Audio

Select "Auto" if you install the audio riser card.

AC97 Modem

Select "Auto" if you install the soft modem riser card.

C. Super IO Device

Onboard FDC Controller

Select Enabled if your system has a floppy disk controller (FDC) installed on the system board and you wish to use it. If you install an add-in FDC or the system has no floppy drive, select Disabled in this field.

COM2 Mode Select

This function allows you to select an operating mode for the second serial port. (Standard RS-232C serial port/IrDA/ASKIR/SCR infrared port)

Onboard Parallel Port

Select a logical LPT port address and corresponding interrupt for the physical parallel port.

D. USB Controller

Enable the on-board Universal Serial Bus (USB) controller if you want to connect a USB keyboard to your system. Note that if this setting is disabled, you can still temporarily use a USB keyboard during bootup so that you can enter BIOS and enable this setting. If you pass the bootup stage without enabling this function, your PS/2 keyboard will no longer work.

E. USB Keyboard Support

If your current operating system doesn't support USB drivers (i.e., DOS) this function must be enabled for USB keyboard operation in these operating systems.

F. Init Display First

This function allows user to choose between onboard AGP or PCI slot to initialise display first .

3-5 Power Management Setup

This section provides information on the Green PC power management functions. By choosing the Power Management Setup option from the Standard CMOS Features menu (Figure 3-1), the screen below is displayed. This sample screen is for reference use only.

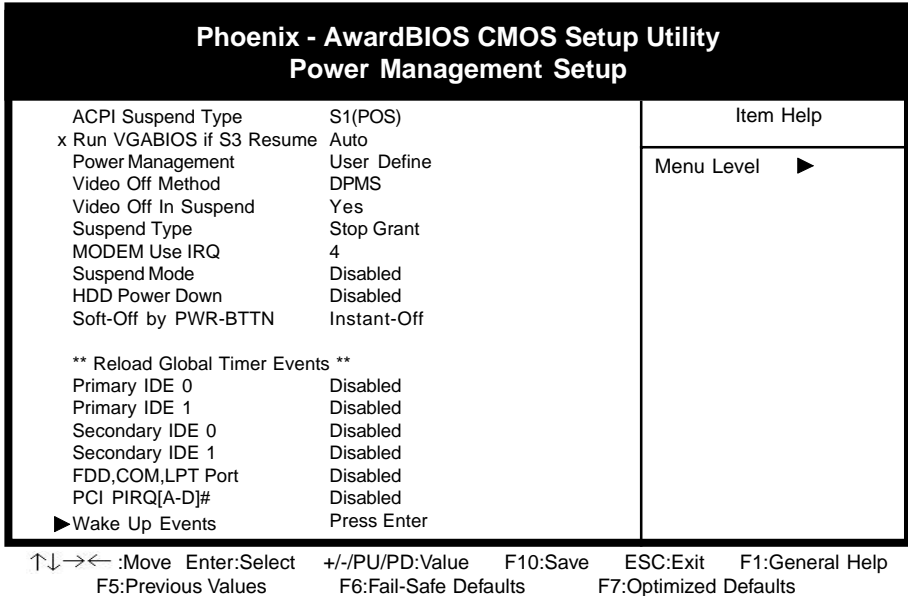

Figure 3-6 Power Management Setup Screen

A. ACPI Suspend Type

This feature allows user to select a suspend type for the operating system to turn off peripherals devices, such as CD-ROM players, when they are not in use.

B. Power Management

Power management allows the computer to save electricity when it is not in use by entering increasingly deep power saving modes.

C. Video Off Method

This function serves as both a screen saver and power saver for monitors. See the next function, Video Off After, for setting the video timer.

Blank - BIOS will only blank the monitor's screen. The electricity saved in this mode is negligible and this function is only used as a screen saver to prevent screen damage while the screen is on but not in use.

V/H SYNC+Blank - The system turns off the vertical and horizontal synchronization ports, writes blanks to the VGA buffer and the monitor's electron gun turns off. This function requires a monitor with Green features in order to take advantage of the power saving function. If you enable this function and do not have a Green monitor, the result will be the same as if you had selected Blank. This function serves as both a screen saver and an electricity saver.

DPMS Supported - Select this option if your video card supports the Display Power Management Signaling (DPMS) standard (i.e., you have a monitor that supports Green features). Use software supplied by your video subsystem to set video power management options.

D. Video Off In Suspend

This setting determines when the monitor enters power saving mode. If set to Yes, the monitor enters the power saving mode after the chosen event expires. The Power Management function must be enabled to use this function.

E. Modem Use IRQ

If your computer has a modem, use this function to tell BIOS which IRQ is being occupied by the modem card. When the system is in Green mode, the modem requires an IRQ assignment to wake up the system and perform tasks. This assignment is compliant with the APM 1.2 specification and is to be used in coordination with APM 1.2 compliant operating systems.

F. Suspend Mode

The Power Management function must not be set to disabled to enable this function. If the system runs in Standby mode and the Suspend timer expires, all devices regulated by power management will shut off and the CPU speed will be 0 MHz.

G. HDD Power Down

The Power Management function must not be set to disabled to enable this function. When the HDD idle time has elapsed, BIOS sends a command to the hard disk to turn off the motor. Set a time between 1 and 15 to indicate time required to wait before the hard drive enters a power saving mode. Some old hard drives may not support this function.

H. Soft-Off by PWR-BTN

When set to Delay 4 Sec., this function allows the power button to put the system in Suspend, a power saving mode. See Section 2-3 for operation instructions of the over-ride power button operation which puts the system in Suspend mode. When set to Instant-Off the Soft-Off by PWR-BTN function is disabled and the computer turns completely off when the power button is pressed.

I. Wake Up Events

Power On PCI Card

When enabled, a PCI interface that receives a signal will wake up the system from soft off and green mode.

Power On By Modem

When enabled, a modem that receives a signal will wake up the system from soft off and green mode. You should connect the modem to the COM port and turn on the resume event in green mode.

Wake Up On LAN

When enabled, a LAN that receives a signal will wake up the system from soft off and green mode.

USB Power On from S3

When enabled, the system is able to power on from S3 mode by a USB keyboard hot key or mouse click.

Power On By Alarm

When enabled, this setting allows the system to turn back on at a designated time of the month. User must designate date of month and time of day. This function is only available when using an ATX power supply and the Software Power-Off function to turn off the computer. See the Software Power-Off feature in Section 2-4 of this manual for instructions.

Power On Function

Select Button Only to control your computer power by the button on your system case. Set this function to Any Key to turn on the computer by touching any key on the keyboard. Set this function to Mouse Click to turn on the computer by clicking on the mouse. If you set this function to Hot Key or Password you must designate the keystrokes that will turn on the computer. Note that the power button is always able to turn on the computer regardless of how this function is set.

3-6 PNP/PCI Configuration

This section provides IRQ and DMA setting information. By choosing the PNP/PCI Configuration option from the Standard CMOS Features menu (Figure 3-1), the screen below is displayed. This sample screen is for reference use only.

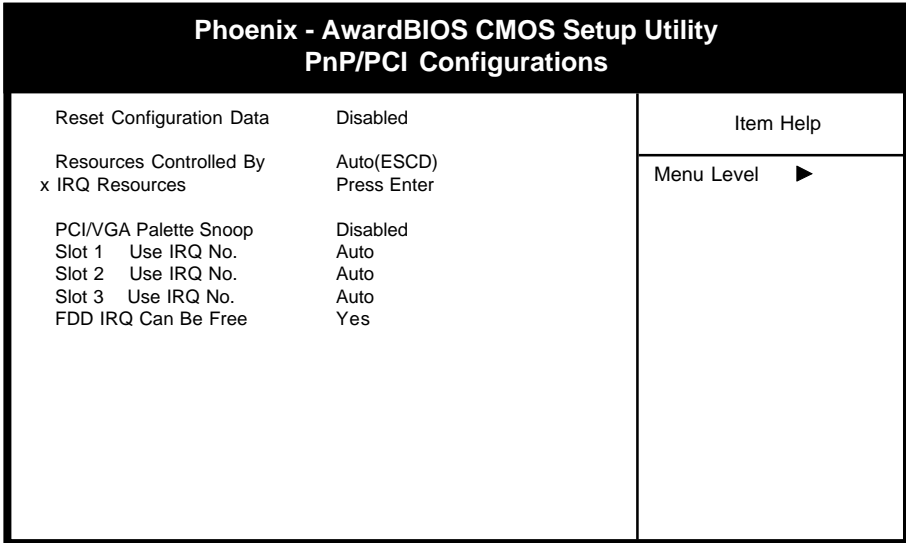

↑↓→←:Move Enter:Select +/-/PU/PD:Value F10:Save ESC:Exit F1:General Help
 F5:Previous Values F6:Fail-Safe Defaults F7:Optimized Defaults

Figure 3-7 PnP/PCI Configurations Screen

A. Resources Controlled By

When set to Manual the system BIOS will not refer to the ESCD for IRQ & DMA information. Instead, it will refer to the items in the setup menu for assigning IRQ & DMA. When set to Auto the system BIOS will refer to the ESCD for all legacy information.



ESCD(Extended System Configuration Data) provides a detailed format of the configuration data structures stored in flash memory. Each data structure defines the resources used by a device or a card in the system. This includes legacy and PCI/ISA PnP devices.

B. FDD IRQ Can Be Free

This function allows user to choose if the FDD IRQ is able to be freed up. The default setting is Yes and this does not allow the IRQ to be free.

3-7 PC Health Status

By choosing the PC Health Status option from the CMOS Setup Utility menu (Figure 3-1), the screen below is displayed. This field shows you the current system temperature/external voltages input and the current CPU FAN and System FAN operating speed.

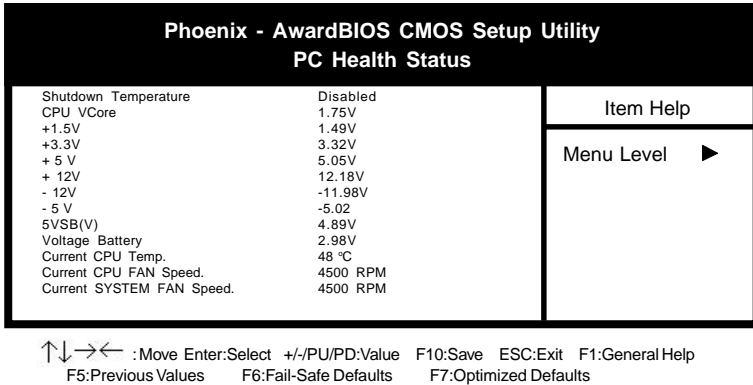

Figure 3-8 PC Health Status Screen

3-8 Frequency/Voltage Control

By choosing the Frequency/Voltage Control option from the CMOS Setup Utility menu (Figure 3-1), the screen below is displayed. This sample screen is for reference use only.

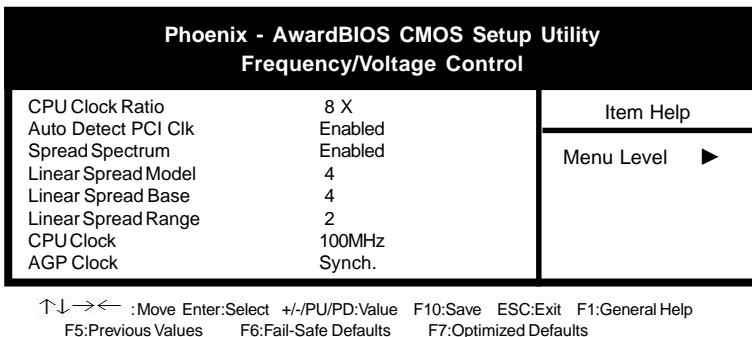

Figure 3-9 Frequency/Voltage Control Screen

A. CPU Clock Ratio

This feature allows user to manually configure your CPU clock ratio according to your processor's specifications.

B. CPU Clock

This feature allows the system memory to run at CPU clock speed. The default setting is at 100MHz.

3-9 Load Fail-Safe Defaults

Load Fail-Safe Defaults loads the default BIOS values directly from the CMOS Setup Utility menu (Figure3-1). If the stored record created by the setup program becomes corrupted and therefore unusable, these defaults will be loaded automatically when you turn on the computer.

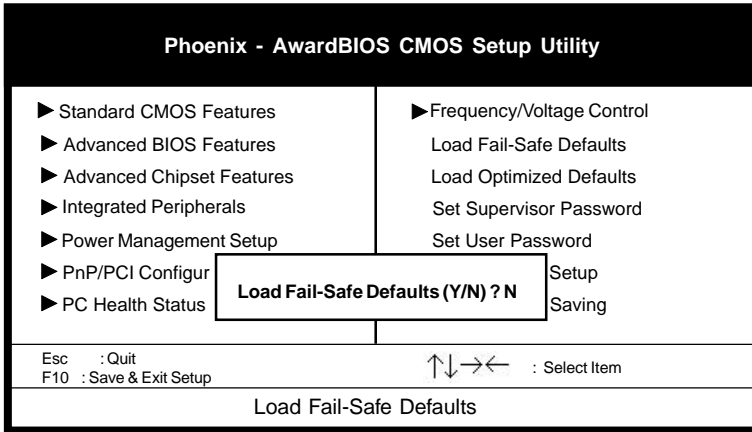

Figure 3-10 Load Fail-Safe Defaults Screen

3-10 Load Optimized Defaults

Load Optimized Defaults loads the default system values directly from the CMOS Setup Utility menu (Figure3-1). If the stored record created by the setup program becomes corrupted and therefore unusable, these defaults will be loaded automatically when you turn on the computer.

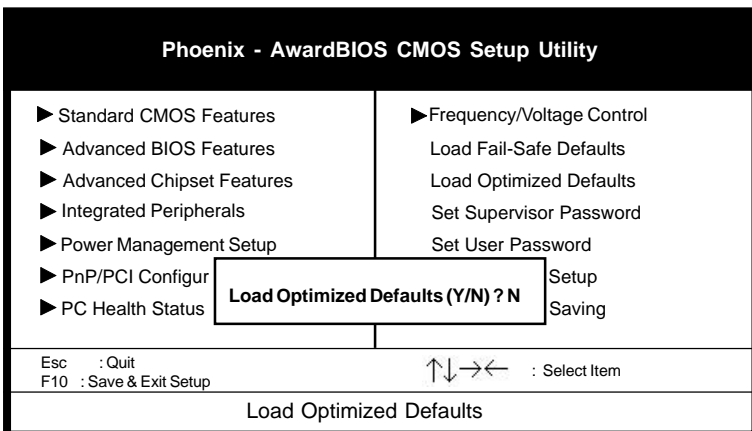

Figure 3-11 Load Optimized Defaults Screen

3-11 Supervisor Password & User Password Setting

There are four different variables that control password settings. The first two are located under the Security Option function in BIOS Features Setup Menu (Figure 3-1). When the Security Option function is set to Setup, a password is required to enter BIOS and change BIOS settings. When the Security Option function is set to System, a password is required to enter both BIOS and the computer's operating system (for example Windows 98) found on the boot drive.

The third and fourth variables are user password and supervisor password selected in BIOS (Figure 3-1). The main purpose of separating user and supervisor is to allow only the supervisor to have control over the settings in BIOS. The user, on the other hand, is only allowed to access the computer's operating system and change the user password in BIOS. Note that when there is no supervisor password set, the user password controls access to all BIOS settings.

3-12 Save and Exit Setup

If you select this and type Y (for yes) followed by the [Enter] key, the values entered in the setup utilities will be recorded in the CMOS memory of the BIOS chip.

3-13 Exit Without Saving

Selecting this option and pressing Y followed by the [Enter] key lets you exit the Setup program without recording any new values or changing old ones.

Thiz Linux Desktop 6.0 (option)

Leading edge technology that brings you the most powerful enjoyment!

Thiz Linux Desktop 6.0, based on the pioneering technology used in Thiz Linux Desktop 5.0, enhancing a variety of new function that would absolutely brings you a more stable, advanced and easy-to use platform enjoyment.

To use Thiz Linux Desktop 6.0, you need:

- A PC with Intel Pentium II or higher processor; or X86-compatible processor such as AMD Duron, Athlon (Pentium III 800MHz or the equivalent recommended);
- Minimum 64MB of memory (128MB or above recommended);
- Minimum 1.6GB hard disk space (over 2GB or more recommended);
- A CD-ROM drive
- A VESA 2.0 standard display card

***Note:** Actual requirements will vary based on your system configuration and on what features you choose to install.

Installation Overview

It's wise to collect configuration information on your hardware before installing. Know the vendor and model number of each card in your machine; collect the IRQs and DMA channel numbers. You probably won't need this information but if it turns out you do, you'll need it very badly.

If you want to run a "dual-boot" system (Linux and DOS or Windows or both), rearrange (repartition) your disk to make room for Linux. If you're wise, you'll back up everything first!.

Installation The Easy Way

1. Set your computer to boot from CD-ROM drive by turning on the system, press the "Delete" key to enter the Advanced BIOS Features option from the Standard CMOS Features menu and change the First Boot Device to CD-ROM (See Section 3-2).
2. Then insert the installation CD-ROM and then reboot. You're started.
3. Select the language mode of your choice and follow the online instruction to finish installation and then reboot from your hard drive.
4. Type "thiz" password and click on "Go" button to enter your Linux desktop to configures your user/password, network, modem dialup configuration and etc...

***Note:** For the latest driver updates, you can download these new drivers at <http://www.chaintech.thizlinux.com>