

Mainboard User's Manual

This publication, photographs, illustrations and software are under the protection of international copyright laws and all rights reserved. It does not allow any reproduction of this manual, content and any materials contained herein without the written consent of the authentic manufacturer.

The information in this manual is subject to change without notice. The manufacturer does neither represent nor warrant the contents hereof; and specifically disclaims any implied warranties of merchantability or fitness for any particular purpose. Furthermore, the manufacturer reserves the right to revise and change this publication from time to time, without the obligation of notifying any person of such revision or changes.

Trademarks

IBM, VGA, and PS/2 are registered trademarks of International Business Machines.

AMD is registered trademark of Advanced Micro Devices Inc.

Intel, Pentium/II/III/IV, Celeron and MMX are registered trademarks of Intel Corporation.

Microsoft, MS-DOS and Windows NT/95/98/ME/2000 are registered trademarks of Microsoft Corporation.

PC-cillin is a registered trademark of Trend Micro Inc.

AMI is a registered trademark of American Megatrends Inc.

A3D is a registered trademark of Aureal Inc.

MediaRing Talk is a registered trademark of MediaRing Inc.

3Deep is a registered trademark of E-Color Inc.

SiS is a trademark of Silicon Integrated System Corporation.

Other names used in this publication may be trademarks and are acknowledged.

**Copyright © 2001
All Rights Reserved
M841 Series, V1.2
S740/November 2001**

Mainboard User's Manual

Notice:

Owing to Microsoft's certifying schedule is various to every supplier, we might have some drivers not certified yet by Microsoft. Therefore, it might happen under Windows XP that a dialogue box (shown as below) pop out warning you this software has not passed Windows Logo testing to verify its compatibility with Windows XP. Please rest assured that our RD department has already tested and verified these drivers. Just click the "Continue Anyway" button and go ahead the installation.



Mainboard User's Manual

Table of Contents

Trademarks.....	I
Chapter 1: Introduction.....	1
Key Features.....	2
Package Contents.....	5
Static Electricity Precautions.....	6
Pre-Installation Inspection.....	6
Chapter 2: Mainboard Installation.....	7
Mainboard Components.....	8
I/O Ports.....	9
Install A CPU.....	9
Install Memory.....	10
Setting Jumper Switches.....	12
Install the Mainboard.....	13
Optional Extension Brackets.....	14
Install Other Devices.....	15
Expansion Slots.....	17
Chapter 3: BIOS Setup Utility.....	19
Introduction.....	19
Running the Setup Utility.....	20
Standard CMOS Setup Page.....	21
Advanced Setup Page.....	22
Power Management Setup Page.....	24
PCI / Plug and Play Setup Page.....	25
Load Optimal Settings.....	26
Load Best Performance Settings.....	26
Features Setup Page.....	26
CPU PnP Setup Page.....	28
Hardware Monitor Page.....	29
Change Password.....	29
Exit.....	30
Chapter 4: Software & Applications.....	31
Introduction.....	31
Installing Support Software.....	31
Auto-installing under Windows 98.....	34

Mainboard User's Manual

Chapter 1

Introduction

This mainboard has a **Socket-462** processor socket for the **AMD K7** type of processors. You can install any of these processors on this mainboard. This mainboard supports front-side bus speed of **200/266MHz**.

This mainboard uses **SiS 740** chipset that supports a **DDR** interface, **Ultra DMA 33/66/100** function and remarkably high system performance under all types of system operations. This mainboard has a built-in **AC97 Codec**, providing an **AMR** (Audio Modem Riser) slot to support Audio and Modem application, and a built-in **10BaseT/100BaseTX Network Interface**. This mainboard has the **embedded 256-bit 3D AGP Graphics Accelerator** with 64MB frame buffer, supporting **AGP 4X 266MHz** mode up to 2GB/s bandwidth, which provides a direct connection between the graphics sub-system and memory so that the graphics do not have to compete for processor time with other devices on the PCI bus. In addition, this mainboard has an extended set of **ATX I/O Ports** including PS/2 keyboard and mouse ports, two USB ports, a parallel port, one serial port and one VGA port. Connecting the Extended USB Module to this mainboard can add two extra USB ports.

This mainboard has all features you need to develop a powerful multimedia workstation. The board is **Micro ATX size** and has power connectors for an **ATX** power supply.

Mainboard User's Manual

Key Features

The key features of this mainboard include:

Socket-462 Processor Support

- ◆ Supports AMD **Athlon XP/Athlon/Duron** processors
- ◆ Supports 200/266 MHz Front-Side Bus

Processors are automatically configured using firmware and a synchronous Host/DRAM Clock Scheme.

Memory Support

- ◆ Two 168-pin DIMM slots for SDRAM memory modules
- ◆ Two 184-pin DIMM slots for DDR memory modules
- ◆ Support SDRAM up to 133 MHz /DDR up to 266 MHz memory bus
- ◆ Maximum installed memory is 2GB

Notice: You can NOT use SDRAM and DDR simultaneously.

VGA

- ◆ Embedded 256-bit 3D AGP Graphics Accelerator with 64MB frame buffer
- ◆ Supports AGP 4X 266 MHz mode up to 2GB/s bandwidth
- ◆ Supports 333MHz true-colorm RAMDAC, resolution up to 2048 x 1536 x 16 bpp NI
- ◆ Supports AGP Rev. 2.0 Spec. Compliant

Expansion Slots

- ◆ One AMR slot for a special audio/modem riser card
- ◆ Three 32-bit PCI slots for PCI 2.2-compliant bus interface

Onboard IDE channels

- ◆ Primary and Secondary PCI IDE channels
- ◆ Support for PIO (programmable input/output) modes
- ◆ Support for Multiword DMA modes
- ◆ Support for Bus Mastering and Ultra DMA 33/**66/100** modes

1: Introduction

Power Supply and Power Management

- ◆ ATX power supply connector
- ◆ Meets ACPI 1.0b and APM 1.2 requirements, keyboard power on/off
- ◆ Supports Suspend, Shutdown, Wake on LAN, Wake on Modem, Wake on Alarm, Interrupt Wake-up from Keyboard/Mouse

AC97 Codec

- ◆ Compliant AC97 2.1 specification
- ◆ Supports 18-bit ADC (Analog Digital Converter) and DAC (Digital Analog Converter) as well as 18-bit stereo full-duplex codec

Built-in Ethernet LAN

- ◆ Built-in **10BaseT/100BaseTX Ethernet LAN**
- ◆ LAN controller integrates Fast Ethernet MAC and PHY compliant with IEEE802.3u 100BASE-TX, 10BASE-T and ANSI X3.263 TP-PMD standards
- ◆ Compliant with ACPI 1.0 and the Network Device Class Power Management 1.0
- ◆ High Performance provided by 100Mbps clock generator and data recovery circuit for 100Mbps receiver

Onboard I/O Ports

- ◆ Built-in Multi-threaded IO Link Delivering 1.2GB/s
- ◆ Provides PC99 Color Connectors for easy peripheral device connections
- ◆ Floppy disk drive connector with 1Mb/s transfer rate
- ◆ One serial port with 16550-compatible fast UART
- ◆ One VGA port
- ◆ One parallel port with ECP and EPP support
- ◆ Two USB ports and optional two USB ports module
- ◆ Two PS/2 ports for keyboard and mouse
- ◆ One infrared port connector for optional module

Mainboard User's Manual

Hardware Monitoring

- ◆ Built-in Hardware Monitor circuit supports Thermal, Power and Fan Speed monitor

Onboard Flash ROM

- ◆ Supports 2MB Flash Rom on board, provides complete Advance Configuration Power Interface(ACPI) and Legacy PMU
- ◆ Supports Ultra DMA 66/100 and fully compliant with PC'97 and PC 98 Spec.

Bundled Software

- ◆ **PC-Cillin2000** provides automatic virus protection under Windows 95/98/NT/2000
- ◆ **MediaRing Talk** provides PC to PC or PC to Phone internet phone communication
- ◆ **3Deep** delivers the precise imagery and displays accurate color in your monitor
- ◆ **WinDVD2000** is a DVD playback application (optional)
- ◆ **Recovery Genius 21st V5.0** provides the function to recover, reserve and transfer hard disk data.
- ◆ **CD Ghost** is the software stimulating a real CD-ROM to perform equivalent function.
- ◆ **Language Genius 21st** is the software to provides learning tools of language and singing.

Dimensions

- ◆ Micro ATX form factor (24.5cm x 24.5cm)

1: Introduction

Package Contents

Attention: This mainboard series consists of two models, M841LR (LAN Ready) and M841 (without LAN).

Please contact your local supplier for more information about your purchased model. Each model supports different specification listed as below:

Model	Specification
M841LR	Onboard LAN PHY(U15) and LAN (RJ45) connector
M841	---

Your mainboard package ships with the following items:

- The mainboard
- This User's Guide
- 1 UDMA/66 IDE cable
- 1 Floppy disk drive cable
- Support software on CD-ROM disk

Optional Accessories

You can purchase the following optional accessories for this mainboard.

- Extended USB module
- AMR v.90 56K Fax/Modem card

Mainboard User's Manual

Static Electricity Precautions

Static electricity could damage components on this mainboard. Take the following precautions while unpacking this mainboard and installing it in a system.

1. Don't take this mainboard and components out of their original static-proof package until you are ready to install them.
2. While installing, please wear a grounded wrist strap if possible. If you don't have a wrist strap, discharge static electricity by touching the bare metal of the system chassis.
3. Carefully hold this mainboard by its edges. Do not touch those components unless it is absolutely necessary. Put this mainboard on the top of static-protection package with component side facing up while installing.

Pre-Installation Inspection

1. Inspect this mainboard whether there are any damages to components and connectors on the board.
2. If you suspect this mainboard has been damaged, do not connect power to the system. Contact your mainboard vendor about those damages.

Chapter 2

Mainboard Installation

To install this mainboard in a system, please follow the instructions in this chapter:

- ❑ Identify the mainboard components
- ❑ Install a CPU
- ❑ Install one or more system memory modules
- ❑ Verify that all jumpers or switches are set correctly
- ❑ Install the mainboard in a system chassis (case)
- ❑ Connect any extension brackets or cables to connecting headers on the mainboard
- ❑ Install other devices and make the appropriate connections to the mainboard connecting headers.

Note:

1. Before installing this mainboard, make sure jumper JP1 is under Normal setting. See this chapter for information about locating JP1 and the setting options.
2. Never connect power to the system during installation; otherwise, it may damage the mainboard.

Mainboard User's Manual

Mainboard Components

Use the diagram below to identify the major components on the mainboard.

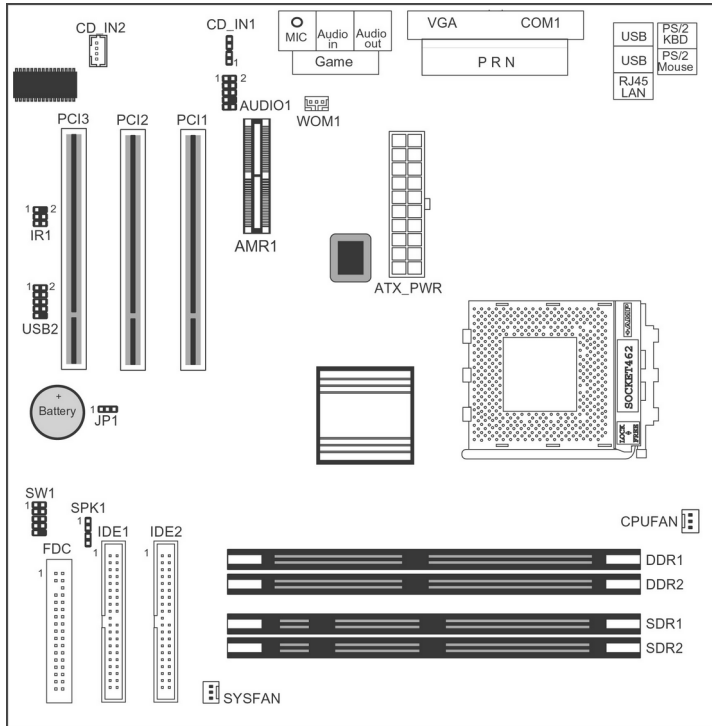

Note: Any jumper on your mainboard that do not appear in the illustration above is for testing only.

2: Mainboard Installation

I/O Ports

The illustration below shows a side view of the built-in I/O ports on the mainboard.

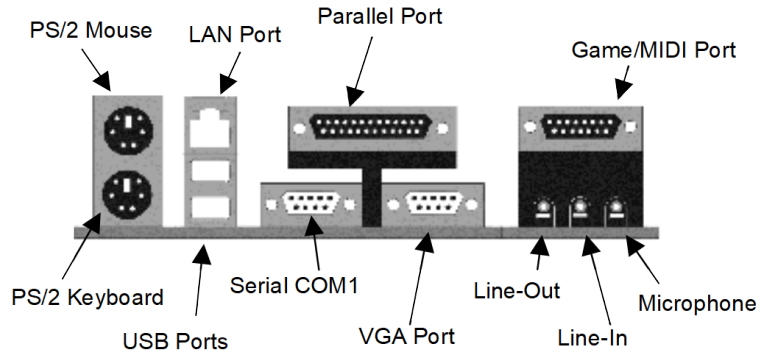

Install A CPU

This mainboard has a Socket-462 that supports AMD K7 processors.

To ensure reliability, ensure that your processor has a heatsink/cooling fan assembly.

Do not try to install a Socket-370/Socket-7 processor in the Socket-462. A Socket-370/Socket-7 processor such as the PPGA Celeron, FCPGA Pentium-III, Pentium-MMX, or the AMD K5/K6 does not fit in the Socket-462.

The following list indicates these processors are currently supported by this mainboard.

Athlon XP: 1500+ ~ 1900+; FSB: 266 MHz

Athlon/Duron: 500M ~ 1.4GHz; FSB: 200 MHz, 266 MHz

Mainboard User's Manual

Installing a Socket-462 Processor

Install a processor into the ZIF (Zero Insertion Force) Socket-462 on the mainboard.

1. Locate the Socket-462 and CPUFAN. Pull the locking lever out slightly from the socket and raise it to the upright position.

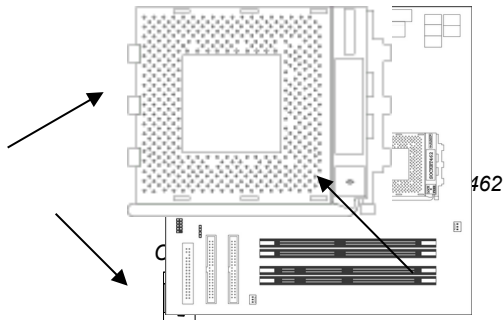

2. On the processor, identify the Pin-1 corner by its beveled edge.
3. On the Socket-462, identify the Pin-1 corner. The Pin-1 corner is at the top of the locking lever when it is locked.
4. Match the Pin-1 corners and insert the processor into the socket. No force is required and the processor should drop into place freely.
5. Swing the locking lever down and hook it under the catch on the side of the socket. This secures the CPU in the socket.
6. All processors should be installed with a combination heatsink/cooling fan, connect the cable from the fan to the CPU fan power connector CPUFAN.

Install Memory

The mainboard has two 168-pin/184-pin DIMM sockets for SDRAM/DDR (Double Data Rate) SDRAM system memory modules. You must install at least one memory module in order to work out the mainboard, **either SDRAM or DDR SDRAM, but you can not use them simultaneously.**

2: Mainboard Installation

DDR SDRAM provides 800 MBps or 1 GBps data transfer depending on whether the bus is 100 MHz or 266 MHz. It doubles the rate to 1.6 GBps and 2.1 GBps by transferring data on both the rising and falling edges of the clock. DDR SDRAM uses additional power and ground lines and requires 184-pin 2.5V unbuffered DIMM module rather than the 168-pin 3.3V unbuffered DIMMs used by SDRAM.

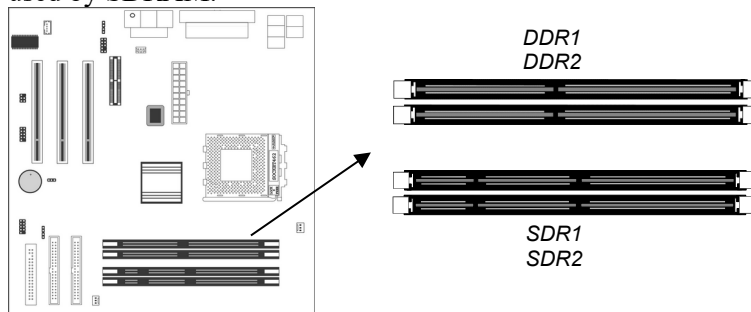

For this mainboard, the maximum memory size is 2GB.

The edge connectors on the memory modules have cut outs, which coincide with spacers in the DIMM sockets so that memory module can only be installed in the correct orientation.

To install a module, push the retaining latches at either end of the socket outwards. Position the memory module correctly and insert it into the DIMM socket. Press the module down into the socket so that the retaining latches rotate up and secure the module in place by fitting into notches on the edge of the module.

Mainboard User's Manual

Setting Jumper Switches

Jumpers are sets of pins which can be connected together with jumper caps. The jumper caps change the way the mainboard operates by changing the electronic circuits on the mainboard. If a jumper cap connects two pins, we say the pins are SHORT. If a jumper cap is removed from two pins, the pins are OPEN.

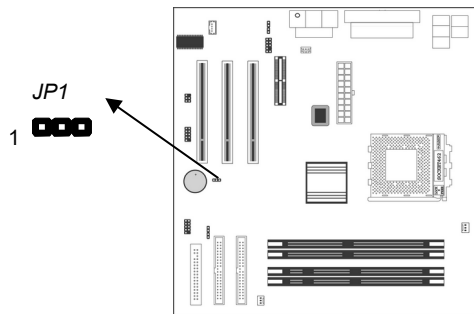

Jumper JP1: Clear CMOS Memory

This jumper can clear the contents of the CMOS memory. You may need to clear the CMOS memory if the settings in the Setup Utility are incorrect and prevent your mainboard from operating. To clear the CMOS memory, disconnect all the power cables from the mainboard and then move the jumper cap into the CLEAR setting for a few seconds.

Function	Jumper Setting
Clear CMOS Memory	Short Pins 1-2
Normal Operation	Short Pins 2-3

2: Mainboard Installation

Install the Mainboard

Install the mainboard in a system chassis (case). The board is an ATX size mainboard with a twin-tier of I/O ports. You can install this mainboard in an ATX case. Ensure that your case has an I/O cover plate that matches the ports on this mainboard.

Install the mainboard in a case. Follow the instructions provided by the case manufacturer using the hardware and internal mounting points on the chassis.

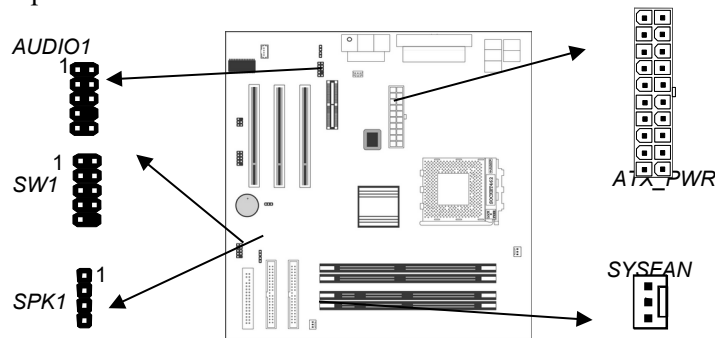

Connect the power connector from the power supply to the **ATX_PWR** connector on the mainboard.

If there is a cooling fan installed in the system chassis, connect the cable from the cooling fan to the **SYSEAN** fan power connector on the mainboard.

Connect the cable from the PC speaker to the **SPK1** header on the mainboard.

Connect the case switches and indicator LEDs to the **SW1** header.

If there are a headphone jack or/and a microphone jack on the front panel, connect the cables to the **AUDIO1** header on the mainboard.

See the illustrations below for the guide to the SW1 and AUDIO1 headers pin assignments.

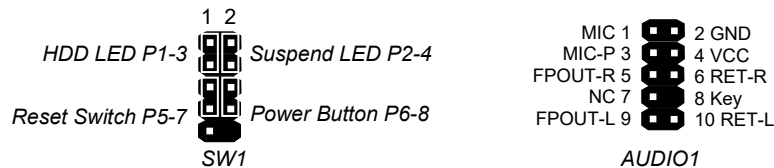

Mainboard User's Manual

Optional Extension Brackets

For this mainboard, you can also obtain a USB module extension bracket for more USB ports. Install them by following the steps below.

Note: All the ribbon cables used on the extension brackets have a red stripe on the Pin-1 side of the cable.

Extended USB Module

This module bracket has two USB ports for more USB devices (USB port 3-4).

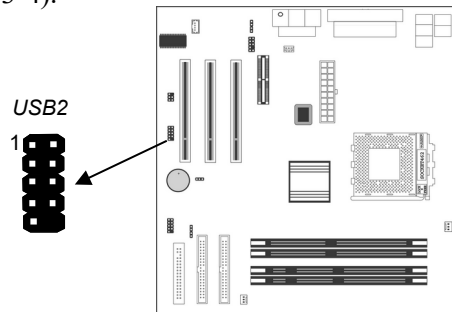

1. Locate the USB2 header on the mainboard.
2. Plug the bracket cable onto the USB2 header.
3. In the system chassis, remove a slot cover from one of the expansion slots and install the extension bracket in the opening. Use the screw that held the slot cover to secure the extension bracket in the chassis.

2: Mainboard Installation

Install Other Devices

Install and connect any other devices in the system following the steps below.

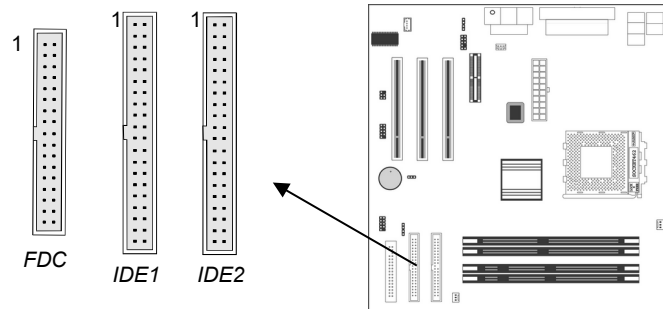

Floppy Disk Drive

The mainboard ships with a floppy disk drive cable that can support one or two drives. Drives can be 3.5" or 5.25" wide, with capacities of 360K, 720K, 1.2MB, 1.44MB, or 2.88MB.

Install your drives and connect power from the system power supply. Use the cable provided to connect the drives to the floppy disk drive connector **FDC**.

IDE Devices

IDE devices include hard disk drives, high-density diskette drives, and CD-ROM or DVD-ROM drives, among others.

The mainboard ships with an IDE cable that can support one or two IDE devices. If you connect two devices to a single cable, you must configure one of the drives as Master and one of the drives as Slave. The documentation of the IDE device will tell you how to configure the device as a Master or Slave device. The Master device connects to the end of the cable.

Install the device(s) and connect power from the system power supply. Use the cable provided to connect the device(s) to the Primary IDE channel connector **IDE1** on the mainboard.

If you want to install more IDE devices, you can purchase a second IDE cable and connect one or two devices to the Secondary IDE channel connector **IDE2** on the mainboard. If you have two devices on the cable, one must be Master and one must be Slave.

Mainboard User's Manual

Internal Sound Connections

If you have installed a CD-ROM drive or DVD-ROM drive, you can connect the drive audio cable to the onboard sound system. On the mainboard, locate the two 4-pin connectors **CD_IN1** and **CD_IN2**. There are two kinds of connectors because different brands of CD-ROM drives have different kinds of audio cable connectors. Connect the cable to the appropriate connector.

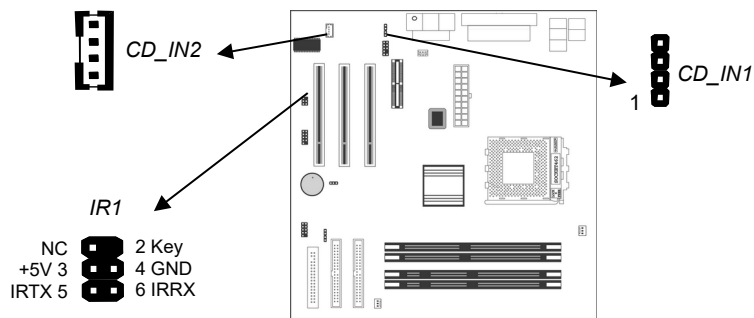

Infrared Port

You can connect an infrared port to the mainboard. You can purchase this option from third-party vendors.

1. Locate the infrared port **IR1** header on the mainboard.
2. If you are adding an infrared port, connect the ribbon cable from the port to the **IR1** header and then secure the port to an appropriate place in your system chassis.

2: Mainboard Installation

Expansion Slots

This mainboard has three 32-bit PCI slots and one AMR slot.

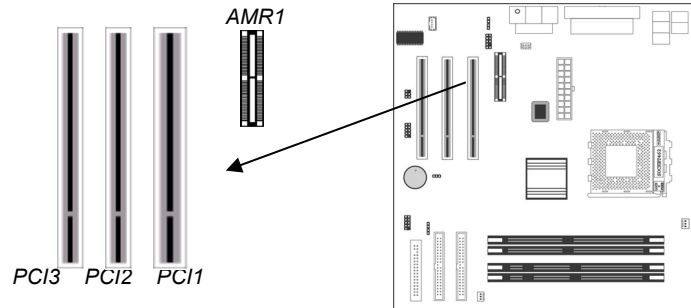

Follow the steps below to install a PCI/AMR expansion card.

1. Locate the AMR or PCI slots on the mainboard.
2. Remove slot cover from the system chassis.
3. Insert edge connector of expansion card into the slot, press down firmly inside until fully inserted.
4. Secure the expansion card bracket to the system chassis with the screw that held the slot cover.

AMR Slot

The AMR (Audio Modem Riser) slot is an industry standard slot that allows for the installation of a special audio/modem riser card. Different territories have different regulations regarding the specifications of a modem card. You can purchase an AMR card that is approved in your area and install it directly into the AMR slot.

Mainboard User's Manual

Chapter 3

BIOS Setup Utility

Introduction

The BIOS Setup Utility records computer's settings and information, such as date and time, type of installed hardware, and various configuration settings. Your computer applies the information to initialize all the components when booting up, and basic functions of overall coordination between system components.

If the Setup Utility configuration is incorrect, it may cause system's malfunction. It can even keep your computer from booting properly. If it happens, you can use the clear CMOS jumper to clear the CMOS memory that has stored the configuration information.

You can run the setup utility and manually make changes to the configuration. You might need to do this to configure some of the hardware that you install on or connect to the mainboard, such as the CPU, system memory, disk drives, etc.

Mainboard User's Manual

Running the Setup Utility

Each time your computer starts, before the operating system loads, a message appears on the screen that prompts you to “Hit if you want to run SETUP”. When you see this message, press the **Delete** key and the Main menu page of the Setup Utility appears on your monitor.

AMIBIOS SIMPLE SETUP UTILITY – VERSION 1.21.06
(C) 2000 American Megatrends, Inc. All Rights Reserved

Standard CMOS Setup	Features Setup
Advanced Setup	CPU PnP Setup
Power Management Setup	Hardware Monitor
PCI / Plug and Play Setup	Change Password
Load Optimal Settings	Exit
Load Best Performance Settings	
Esc : Quit ↑ ↓ ← →: Select Item (Shift)F2 : Change Color F5 : Old Values F6 : Optimal values F7 : Best performance values F10 : Save&Exit	
Standards CMOS setup for changing time, date, hard disk type, etc.	

You can use the cursor arrow keys to highlight any of the options on the main menu page. Press **Enter** to select the highlighted option. To leave the setup utility, press the **Escape** key. To cycle through the Setup Utility's optional color schemes hold down the **Shift** key and press **F2**.

Some of the options on the main menu page lead to tables of items with installed values. In these pages, use the cursor arrow keys to highlight the items, and then use the **PgUp** and **PgDn** keys to cycle through the alternate values for each of the items. Other options on the main menu page lead to dialog boxes which require you to answer Yes or No by hitting the **Y** or **N** keys.

If you have already made changes to the setup utility, press **F10** to save those changes and exit the utility. Press **F5** to reset the changes to the original values. Press **F6** to install the setup utility with a set of default values. Press **F7** to install the setup utility with a set of high-performance values.

3: BIOS Setup Utility

Standard CMOS Setup Page

Use this page to set basic information such as the date, the time, the IDE devices, and the diskette drives. If you press the F3 key, the system will automatically detect and configure the hard disks on the IDE channels.

AMIBIOS SETUP – STANDARD CMOS SETUP										
(C) 2000 American Megatrends, Inc. All Rights Reserved										
Date (mm/dd/yy) : Wed Nov 14, 2001										
Time (hh/mm/ss) : 15:06:30										
	Type	Size	Cyln	Head	WPcom	Sec	LBA Mode	Blk Mode	PIO Mode	32Bit Mode
Pri Master	: Auto									On
Pri Slave	: Auto									On
Sec Master	: Auto									On
Sec Slave	: Auto									On
Floppy Drive A : 1.44 MB 31/2										
Floppy Drive B : Not Installed										
Month : Jan – Dec					ESC : Exit					
Day : 01 – 31					↑↓ : Select Item					
Year : 1901 – 2099					PU/PD/+/- : Modify					
					(Shift)F2 : Color					
					F3 : Detect All HDD					

Date & Time	Use these items to set the system date and time
Pri Master	Use these items to configure devices connected to the Primary and Secondary IDE channels. To configure an IDE hard disk drive, choose <i>Auto</i> . If the <i>Auto</i> setting fails to find a hard disk drive, set it to <i>User</i> , and then fill in the hard disk characteristics (Size, Cyls, etc.) manually. If you have a CD-ROM drive, select the setting <i>CDROM</i> . If you have an ATAPI device with removable media (e.g. a ZIP drive or an LS-120) select <i>Floptical</i> .
Pri Slave	
Sec Master	
Sec Slave	
Floppy Drive A Floppy Drive B	Use these items to set the size and capacity of the floppy diskette drive(s) installed in the system.

Mainboard User's Manual

Advanced Setup Page

Use this page to set more advanced information about your system. Take some care with this page. Making changes can affect the operation of your computer.

AMIBIOS SETUP – ADVANCED SETUP			
(C) 2000 American Megatrends, Inc. All Rights Reserved			
Shared Memory Size	32 MB	AGP Comp. Driving	Auto
Quick Boot	Enabled	Manual AGP Comp. Driving	CB
1 st Boot Device	IDE-0	AGP Aperture Size	64MB
2 nd Boot Device	Floppy	Auto detect DIMM/PCI Clk	Disabled
3 rd Boot Device	CDROM	CLK Gen Spread Spectrum	Disabled
Floppy Drive Swap	Disabled		
Password Check	Setup		
Boot To OS/2	No		
System BIOS Cacheable	Enabled		
DRAM Timing Configuration	Normal Mode	ESC : Quit	↑↓←→ : Select Item
SDR/DDR CAS Latency	3T	F1 : Help	PU/PD/+/- : Modify
Auto Detect DIMM/PCI Clk	Enabled	F5 : Old Values (Shift)	F2 : Color
Clk Gen Spread Spectrum	Disabled	F6 : Load BIOS Defaults	
		F7 : Load Setup Defaults	

3: BIOS Setup Utility

Share Memory Size	This item lets you allocate a portion of the main memory for the onboard VGA display application with 16/32/64MB options.
Quick Boot	If you enable this item, the system starts up more quickly by elimination of some of the power on test routines.
1st Boot Device 2nd Boot Device 3rd Boot Device	Use these items to determine the device order the computer uses to look for an operating system to load at start-up time.
Try Other Boot Device	If you enable this item, the system will also search for other boot devices if it fails to find an operating system from the first two locations.
Floppy Drive Swap	If you have two diskette drives installed and you enable this item, drive A becomes drive B and drive B becomes drive A.
Password Check	If you have entered a password for the system, use this item to determine if the password is required to enter the Setup Utility (<i>Setup</i>) or required both at start-up and to enter the Setup Utility (<i>Always</i>).
Boot to OS/2	Enable this item if you are booting the OS/2 operating system and you have more than 64MB of system memory installed.
System BIOS Cacheable	If you enable this item, a segment of the system BIOS will be cached to main memory for faster execution.
DRAM Timing Configuration	This item can determine the DRAM timing configuration mode of the memory, four options of Normal, Fast, Ultra and Safe modes. We recommend that you leave this item at the default value.
SDR/DDR CAS Latency	This item determines the operation of the SDRAM / DDR memory CAS (column address strobe). We recommend that you leave this item at the default value. The 2T setting requires faster memory that specifically supports this mode.
Auto Detect DIMM/PCI Clk	Use this item to enable the DIMMs or PCI slots to detect automatically device then generating clock.
Clk Gen Spread Spectrum	Use this item to enable the clock to generate spread spectrum.

Mainboard User's Manual

Power Management Setup Page

This page sets some of the parameters for system power management operation.

AMIBIOS SETUP – POWER MANAGEMENT SETUP (C) 2000 American Megatrends, Inc. All Rights Reserved		
ACPI Aware O/S	Yes	
Power Management	Enabled	
Suspend Time Out	Disabled	
Hard Disk Time Out	Disabled	
RTC Alarm Power On	Disabled	
RTC Alarm Date	Every Day	
RTC Alarm Hour	12	ESC : Quit ↑↓←→ : Select Item
RTC Alarm Minute	30	F1 : Help PU/PD/+/- : Modify
RTC Alarm Second	00	F5 : Old Values (Shift)F2 : Color
LAN/Ring Power On	Disabled	F6 : Load BIOS Defaults
Keyboard PowerOn Function	Disabked	F7 : Load Setup Defaults

ACPI Aware O/S	Enable this item if you are using an O/S that supports ACPI function such as Windows 98/ME / 2000.
Power Management	Use this item to select a power management scheme. Both APM and ACPI are supported.
Suspend Time Out	This sets the timeout for Suspend mode in minutes. If the time selected passes without any system activity, the computer will enter power-saving Suspend mode.
Hard Disk Time Out	This sets the timeout to power down the hard disk drive, if the time selected passes without any hard disk activity.
RTC Alarm Power On / Date / Hour / Minute / Second	The system can be turned off with a software command. If you enable this item, the system can automatically resume at a fixed time based on the system's RTC (realtime clock). Use the items below this one to set the date and time of the wake-up alarm. You must use an ATX power supply in order to use this feature.

3: BIOS Setup Utility

LAN/Ring Power On	Your system can enter a software power down. If you enable this item, the system can automatically resume if there is traffic on the network adapter.
Keyboard PowerOn Function	If you enable this item, you can turn the system on and off by pressing hot keys on the keyboard. You must enable the Keyboard Power On jumper and use an ATX power supply in order to use this feature.

PCI / Plug and Play Setup Page

This page sets some of the parameters for devices installed on the PCI bus and devices that use the system plug and play capability.

AMIBIOS SETUP – PCI / PLUG AND PLAY SETUP (C) 2000 American Megatrends, Inc. All Rights Reserved	
Plug and Play Aware O/S	Yes
Primary Graphics Adapter	PCI
Allocate IRQ to PCI VGA	Yes
ESC : Quit ↑↓←→ : Select Item F1 : Help PU/PD/+/- : Modify F5 : Old Values (Shift)F2 : Color F6 : Load BIOS Defaults F7 : Load Setup Defaults	

Plug and Play Aware O/S	Enable this item if you are using an O/S that supports Plug and Play such as Windows 95/98/ME.
Primary Graphics Adapter	This item indicates if the primary graphics adapter uses the PCI or the AGP bus. The default PCI setting still lets the onboard display work and allows the use of a second display card installed in a PCI slot.
Allocate IRQ to PCI VGA	If this item is enabled, an IRQ will be assigned to the PCI VGA graphics system. You set this value to No to free up an IRQ.

Mainboard User's Manual

Load Optimal Settings

If you select this item and press **Enter** a dialog box appears. If you press **Y**, and then **Enter**, the Setup Utility loads a set of fail-safe default values. These default values are not very demanding and they should allow your system to function with most kinds of hardware and memory chips.

Note: It is highly recommended that users enter this option to load optimal values for accessing the best performance.

Load Best Performance Settings

If you select this item and press **Enter** a dialog box appears. If you press **Y**, and then **Enter**, the Setup Utility loads a set of best-performance default values. These default values are quite demanding and your system might not function properly if you are using slower memory chips or other low-performance components.

Features Setup Page

This page sets some of the parameters for peripheral devices connected to the system.

AMIBIOS SETUP – FEATURES SETUP (C) 2000 American Megatrends, Inc. All Rights Reserved		
OnBoard FDC	Enabled	ESC : Quit ↑↓←→ : Select Item F1 : Help PU/PD/+/- : Modify F5 : Old Values (Shift)F2 : Color F6 : Load BIOS Defaults F7 : Load Setup Defaults
OnBoard Serial PortA	3F8h/COM1	
OnBoard Ir Port	Disabled	
OnBoard Parallel Port	378h	
Parallel Port Mode	ECP	
Parallel Port IRQ	7	
Parallel Port DMA	3	
OnBoard Game Port	201h	
OnBoard MIDI Port	300	
MIDI Port IRQ	10	
OnBoard PCI IDE	Both	
Audio Device	Enabled	
Modem Device	Enabled	
Ethernet Device	Enabled	
USB Function Support	Enabled	
USB Function for DOS	Disabled	

3: BIOS Setup Utility

Mainboard User's Manual

OnBoard FDC	Use this item to enable or disable the onboard floppy disk drive interface.
OnBoard Serial PortA	Use these items to enable or disable the onboard COM1/2 serial port, and to assign a port address.
OnBoard Ir Port	Use this item to define the protocol for an infrared port if you have installed an optional IR port. The options are IrDA and ASKIR.
Onboard Parallel Port	Use this item to enable or disable the onboard LPT1 parallel port, and to assign a port address. The Auto setting will detect and available address.
Parallel Port Mode	Use this item to set the parallel port mode. You can select SPP (Standard Parallel Port), ECP (Extended Capabilities Port), EPP (Enhanced Parallel Port), or ECP + EPP.
Parallel Port IRQ	Use this item to assign either IRQ 5 or 7 to the parallel port.
Parallel Port DMA	Use this item to assign a DMA channel to the parallel port. The options are 0, 1 and 3.
OnBoard Game Port	Use this item to enable or disable the onboard Game port.
OnBoard MIDI Port	Use this item to enable or disable the onboard MIDI port, and to assign a port address.
MIDI Port IRQ	Use this item to assign an IRQ to the MIDI port.
Onboard PCI IDE	Use this item to enable or disable either or both of the onboard Primary and Secondary IDE channels.
Audio Device	This item enables or disables the onboard AC'97 audio chip.
Modem Device	This item enables or disables the onboard AC'97 modem chip.
Ethernet Device	This item enables or disables the LAN chip.
USB Function Support	Enable this item if you plan to use the USB ports on this mainboard.
USB Function for DOS	Enable this item if you plan to use the USB ports on this mainboard in a DOS environment.

3: BIOS Setup Utility

CPU PnP Setup Page

This page lets you manually configure the mainboard for the CPU. The system will automatically detect the kind of CPU that you have installed and make the appropriate adjustments to the items on this page.

AMIBIOS SETUP – CPU PnP SETUP	
©2000 American Megatrends, Inc. All Rights Reserved	
CPU BRAND	AMD K7
CPU Type	Athlon
CPU Speed	133/133 MHz
CPU Core Voltage	1.704 V
CPU Ratio	9x
CPU Frequency	133 MHz
DRAM Frequency	133 MHz
ESC : Quit ↑↓←→ : Select Item F1 : Help PU/PD/+/- : Modify F5 : Old Values (Shift)F2 : Color F6 : Load Optimal values F7 : Load Best performance values	

CPU Brand/Type/ Core Voltage/Ratio /Frequency	These items show the kind, core voltage, ratio and frequency of CPU that has installed in your system.
CPU Speed	Use this item to set the CPU speed that has installed in your system.
DRAM Frequency	Use this item to set the frequency of DRAM that has installed in your system.

Note: If you manually set the wrong speed and the system won't run properly, press the **Page Up** key while the system is booting and a default setting will replace the incorrect CPU setting.

Mainboard User's Manual

Hardware Monitor Page

This page sets some of the parameters for the hardware monitoring function of this mainboard.

AMIBIOS SETUP – HARDWARE MONITOR (C) 2000 American Megatrends, Inc. All Rights Reserved		
*** System Hardware ***		
Vcore	1.720V	ESC : Quit ↑↓←→ : Select Item F1 : Help PU/PD/+/- : Modify F5 : Old Values (Shift)F2 : Color F6 : Load BIOS Defaults F7 : Load Setup Defaults
Vcc 2.5V	2.496V	
Vcc 3V	3.392V	
Vcc	4.972V	
+12V	12.056V	
SB3V	3.488V	
-12V	-11.721V	
SB5V	4.999V	
VBAT	3.488V	
SYSTEM Fan Speed	0 RPM	
CPU Fan Speed	4821 RPM	
SYSTEM Temperature	38°C/100°F	
CPU Temperature	45°C/113°F	

Voltage Measurements & FAN Speeds	These items indicate cooling fan speeds in RPM and the various system voltage measurements.
System / CPU Temperature	These items display CPU and system temperature measurement.

Change Password

If you highlight this item and press **Enter**, a dialog box appears which lets you enter a Supervisor password. You can enter no more than six letters or numbers. Press **Enter** after you have typed in the password. A second dialog box asks you to retype the password for confirmation. Press **Enter** after you have retyped it correctly. The password is then required to access the Setup Utility or for that and at start-up, depending on the setting of the Password Check item in Advanced Setup.

3: BIOS Setup Utility

Change or Remove the Password

Highlight this item, press **Enter** and type in the current password. At the next dialog box, type in the new password, or just press **Enter** to disable password protection.

Exit

Highlight this item and press **Enter** to save the changes that you have made in the Setup Utility configuration and exit the program. When the Save and Exit dialog box appears, press **Y** to save and exit, or press **N** to exit without saving.

Chapter 4

Software & Applications

Introduction

The support software CD-ROM attached to this mainboard package contains all necessary drivers and utility programs for properly running our products. You can find out a brief description of each software program and the location for your mainboard version as below. More information on some programs is available in a README file, located in the same directory as the software.

If the operating system used in your system is Windows 98, it will automatically install all the drivers and utilities for your board. See the Auto-Installing under Windows 98 section.

Installing Support Software

The software on the support CD-ROM is for Windows 95/NT/2000 and Windows 98. The installation procedure differs depending on which Operating System you have, but the automatic installation is now for Win98/WinME/Win2000.

Installing under Windows 95/NT

To install support software for Windows 95/NT follow this general procedure:

1. Insert the support CD-ROM disc in the CD-ROM drive.
(The system might get an error message from the PnP function. Don't care the message. You don't really need that file to install the drivers)
2. Use My Computer or Windows Explorer to look at the directory structure. You must use the Open command in the right-button menu. Double-clicking on the drive icon will result in an error message because the disc's AutoRun feature doesn't work in Windows 95/NT.
3. Execute the EXE file name given in the description below.

4: Software & Applications

*Note: The correct path name for each software driver is provided, where **D:** identifies the CD-ROM drive letter – modify if necessary.*

AGP Driver

The AGP Drivers allows the system to properly manage the AGP slot on the mainboard. Find the driver here:

- ◆ D:\VGA\AGP\SiS650_740\

VGA Driver

Find the driver here:

D:\VGA\SiS650_740\

Audio Driver

The Audio driver allows the system to use the onboard audio circuitry. Find the driver and audio application here:

- ◆ D:\SOUND\Driver\ SiS650_740\

Network Adapter Driver

Find the network adapter driver here:

- ◆ D:\LAN\SiS900\

AMR Modem Driver

Find the driver here:

- ◆ D:\Modem\Driver\AMR\ SiS650_740\
- ◆ D:\Modem\SuperVoice\ [Telecom management software]
- ◆ D:\Modem\MediaRingTalk\

USB Driver

The USB Driver allows the system to recognize the USB ports on the mainboard. You need to install this driver if you are running Windows 95. Windows 95 OSR2 does not require this driver.

This driver is available for:

- ◆ Win95 – D:\USB\EUSBSUPP\USBSUPP.EXE
- ◆ Win95 (Chinese) – D:\USB\CUSBSUPP\CUSBSUPP.EXE

3Deep Software

Find the software here:

- ◆ D:\3Deep\3Deep 3.3\Setup.EXE

Mainboard User's Manual

BIOS Update Utility

The BIOS Update utility allows you to update the BIOS file on the mainboard to a newer version. You can download the latest version of the BIOS setup available for your mainboard from the website.

- ◆ D:\UTILITY\AMINFxxx.EXE

PC-Cillin Software

The PC-cillin software program provides anti-virus protection for your system. Find this program here:

- ◆ D:\PC-CILLIN\

4: Software & Applications

Auto-installing under Windows 98

The support software CD-ROM disc loads automatically under Windows 98. When you insert the CD-ROM disc in the system CD-ROM drive the Autorun feature will automatically bring up the install screen. The screen has three buttons on it, Setup, Browse CD and Exit. See the following screen illustration.

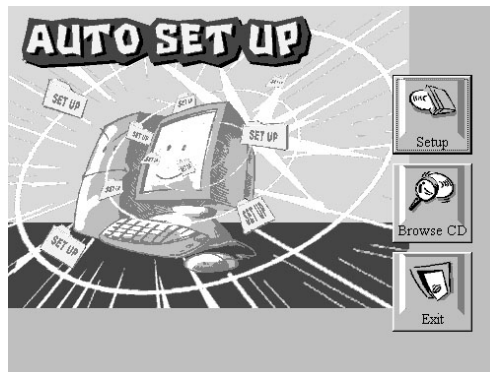

When you click on the **Setup** button the software installation program will run and you can select what kind of installation you want to do, as explained later in this section.

The **Browse CD** button is the standard Windows command that allows you to examine the contents of the disc using the Windows 98 file browsing interface.

The **Exit** button closes the Auto Setup window. To run the program again, reinsert the CD-ROM disc in the drive or click on AutoRun in the context sensitive menu for the CD-ROM drive icon in a file browser window.

Installing Software with Auto Setup

To install support software for the system board follow this procedure:

Mainboard User's Manual

1. Click on the **Setup** button. The install program will load and display the following screen. Click the **Next** button.



2. Select the items that you want to setup by clicking on it (the default options are recommended). Click the **Next** button to proceed.

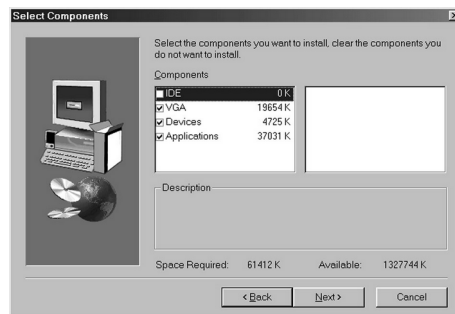

3. The support software will automatically install.

Once any of the installation procedures start, software is automatically installed in sequence. You will need to follow the onscreen instructions, confirm commands and allow the computer to restart as few times as is needed to complete installing whatever software you selected to install. When the process is finished, all the support software will be installed and working.

There are some utilities that you have to manually install if you need, check to the above section.