

Copyright Notices

The information contained in the user's manual and all accompanied documentation are copyrighted and all rights are reserved. This publication may not in whole or in parts, be reproduced, transcribed, stored in a retrieval system translated into any languages or transmitted in any form without the prior written consent from the manufacturer, except for copies retained by the purchasers for their personal archival purposes.

Trademarks

- Award Modular BIOS is a registered trademark of Award Software Inc.
- Microsoft and Windows 95/98/NT are registered trademarks of Microsoft Corporation.
- Intel Pentium, Pentium II, Pentium III, Celeron and Slot1 are registered trademarks of Intel Corporation.

All other product names mentioned herein are used for identification purposes only and may be the trademarks of their respective companies.

Technical Support

If you need technical assistance, our technical support engineers will be glad to assist you with all technical difficulties, you can reach them by dialing our toll-free service and technical support number : 1-877-DELTA-2K/1-877-335-8225 (USA / CANADA Only). Not only you will get to speak with our experience technical support team, we also provide web-site address (**<http://pc.delta.com.tw>**), product ,sales and RMA/warranty information. Our skillful technical engineers will be available between 8:00AM to 5:00PM, PST (Pacific Standard Time).

CONTENTS

1. Checklist.....	2
2. Introduction.....	3
3. Specification.....	4
4. Layout Guide.....	6
5. Function Illustrations.....	8
6. Hardware Installation.....	21
7. BIOS Configuration.....	27
8. Software Installation.....	54

1. Checklist

Check that your package is complete. If any listed items are missing, please contact your retailer immediately. The M81-X series motherboard package contains the following.

- ① Package box
- ② M81-X Series Motherboard
- ③ Anti-static bag
- ④ EPE sheet
- ⑤ Serial cable with bracket
- ⑥ User's Manual
- ⑦ IDE 40-Pin ribbon cable

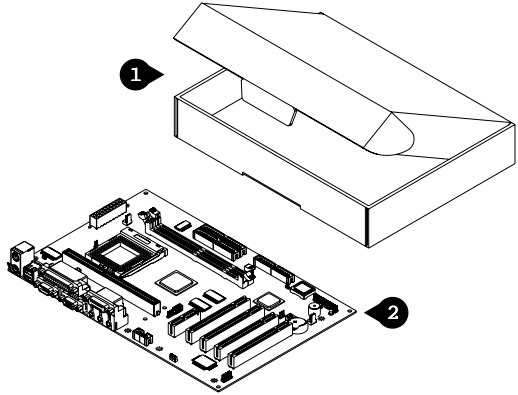

- IDE 40-Pin ribbon cable for Ultra DMA33 HDD

(Note : This item for M81L-X motherboard only.)

- IDE 40-Pin ribbon cable for Ultra DMA33/66 HDD

(Note : The 80-Pin ribbon cable is designed with a 40-Pin connector and this item for M81-X, M81DC-X motherboard.)

- ⑧ Floppy 34-Pin ribbon cable
- ⑨ Driver and Utilities CD

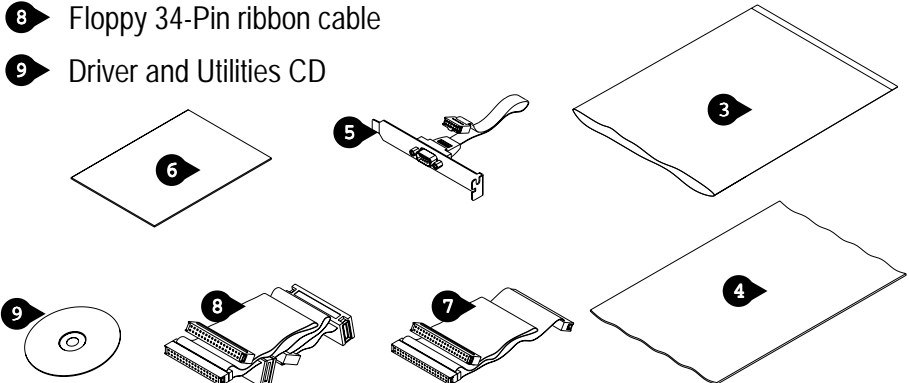

2. Introduction

The key feature of the M81-X series motherboard is the dual Processor socket which allow you to install any of the Slot1 Processor (including Pentium II/III and SEPP Celeron) and PPGA370 Processor.

The Pentium II/III Processor which include 32K of internal level-1 cache memory and 512K of external level-2 cache memory.

- Pentium II Processor can run a 66MHz system bus and operate at clock speed from 233MHz up to 333MHz.
- Pentium II/III Processor also can run a 100MHz system bus and operate at clock speed from 350MHz up to 600MHz.

The SEPP Celeron Processor which include 32K of level-1 cache memory and 128K of level-2 cache memory. It can run a 66/100MHz system bus and operate at clock speeds up to 500MHz. (Note : Celeron 266/300 Processor do not have feature of level-2 cache memory on die).

The PPGA370 Celeron Processor is square plastic package and install in a Zero Insertion Force (ZIF) socket called a PGA370 Socket.

- The new Celeron Processor are close to Pentium II performance because they include a level-2 cache memory of 128K. However, they operate at a 66/100MHz system bus and operate at clock speeds up to 500MHz.

You can configure the motherboard for any of supported Processor System Bus Frequency using the BIOS setup utility. It is not necessary to set switches or jumpers. Also it can Auto-Detect Processor clock speeds of the Slot1 SEPP Celeron and PPGA370 Celeron Processor. This motherboard allows complete flexibility. You can choose the high performance Slot1 Pentium II/III Processor or the inexpensive PPGA370 Celeron Processor according to the system requirements and price/performance comparison of the two kinds of Processor. For performance and upgrade required, we recommend you must install PC-100 compliant DIMM modules that operates at 100MHz.

M81-X series motherboard provides four 32-bit PCI slots and an AMR slot, also has two support Ultra DMA33/66 PCI IDE channel and floppy disk drive peripherals interface.

In addition to superior hardware capabilities, features like Plug and Play, Soft-off, ACPI function, Keyboard Power-On, Wakeup by Ring/LAN, fan off in sleeping state and BIOS upgraded are provided on M81-X series platform.

3. *Specification*

Chipset

- M81L-X Consists of the Intel's FW82810 + FW82801AB
- M81-X Consists of the Intel's FW82810 + FW82801AA
- M81DC-X Consists of the Intel's FW82810DC100 + FW82801AA
- Winbond's W83627HF LPC Super I/O
- AC97 Codec

CPU Support

- Intel's Solt1 Pentium II/III Processors
- Intel's Solt1 SEPP Celeron Processors
- Intel's PPGA370 Celeron Processors

System Bus Frequency

- 66/100MHz System Bus Frequency Supported
- System Bus Frequency and CPU core voltage auto-detected

Memory

- Memory Capacity from 8MB up to 256MB
- Onboard Display Cache 4MB SDRAM interface (M81DC-X only)
- Two DIMM Sockets support PC-100 compliant SDRAMs

Expansion Slots

- Four 32-bit v2.2 PCI Slots support up to 133MB/sec maximum throughput
- One AMR slot supports a very affordable Audio Modem Riser card

On Board I/O

- Dual integrated IDE controller supports Ultra DMA33/66 Mode and PIO Mode 4 (M81L-X motherboard supports Ultra DMA33 Mode and PIO Mode 4 only.)
- Dual high speed UART compatible Serial Ports

3. Specification

- Single STD/ECP/EPP Parallel Port
- Floppy Disk Drive Interface
- Integrated Consumer IR and Standard IR supports (This item is optional)
- Dual Universal Serial Bus Ports
- Dual PS/2 mini DIN supports Keyboard and Mouse
- Integrated 3D/2D AGP Graphics Controller
- Single Game_Audio/Line-in/Line-out/MIC Ports
- Hardware Monitor Functions
- OnNow Functions
- Power Management Functions
- Built-in PCI 3D audio compliant with PC99, Intel AC97 and AMR v1.01

Power

- Harris HIP6021 PWM Power Controller
- ATX Power Supply Configuration

BIOS

- Award Medallion v6.0 BIOS

Compliancies

- DOC Compliant
- CE Certification

Form Factor

- ATX (305 x 200 x 1.6mm)
- 4 Layer PCB Design

4. Layout Guide

Use the following illustration and key to identify the components on your motherboard.

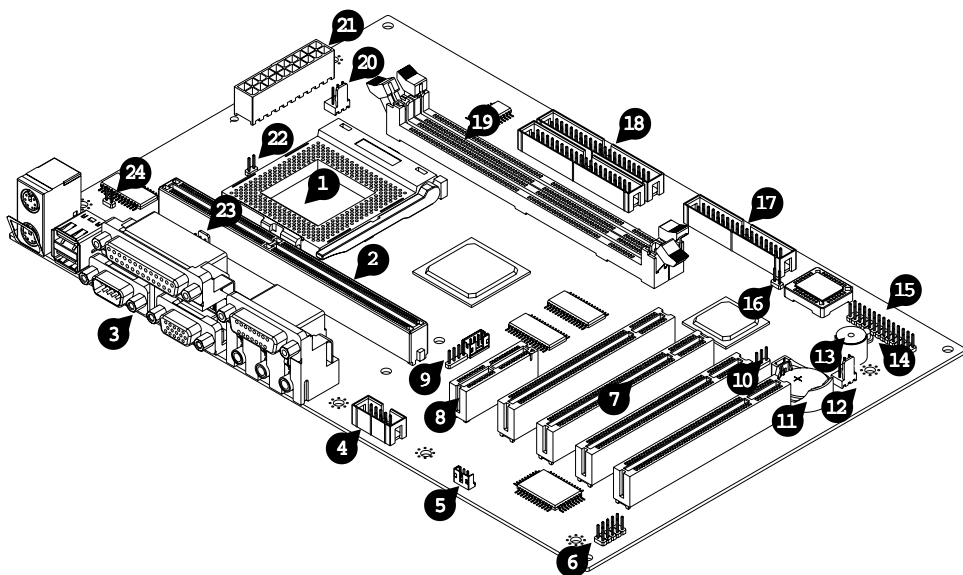

- ➊ PGA370 Socket for Intel's PPGA370 Processors
- ➋ Slot1 Slot for Intel Pentium II/III and SEPP Celeron Processors
- ➌ Back Panel I/O Ports
- ➍ COM2 Serial Header
- ➎ Wake On LAN Connector
- ➏ IrDA compliant IR infrared Header (This item is optional)
- ➐ Four PCI Slots
- ➑ AMR (Audio Modem Riser) Slot

4. Layout Guide

- 9 ▶ CD-In Header
- 10 ▶ CMOS Memory Clear Header
- 11 ▶ Lithium CR2032 Battery
- 12 ▶ Chassis Fan Connector
- 13 ▶ Buzzer
- 14 ▶ Power LED
- 15 ▶ Front Panel I/O Header
- 16 ▶ Flash BIOS Lock Header (This item is optional)
- 17 ▶ FDD Device Header
- 18 ▶ Two IDE (Primary and Secondary) Devices Header
- 19 ▶ Two DIMM Sockets
- 20 ▶ CPU Fan Connector
- 21 ▶ ATX Power Connector
- 22 ▶ Processor Type Setting Header
- 23 ▶ Power Fan Connector
- 24 ▶ Keyboard and Mouse Power On Header

5. Function Illustrations

Refer to this section for details on the hardware configuration. All jumper settings should be configured prior to install the motherboard.

5.1. Processor Slot "Slot1"

- Slot1 slot is a 242-Pin edge slot that can install the Slot1 Pentium II/III and SEPP Celeron Processors.

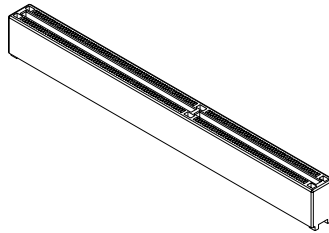
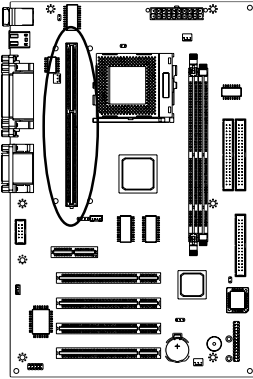

5.2. Processor socket "PGA370"

- PGA370 socket is a 370-Pin ZIF socket that can install the PPGA370 Celeron Processors.

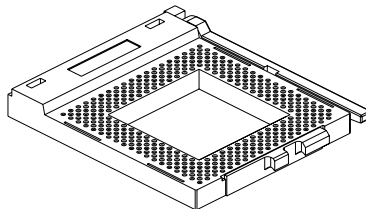
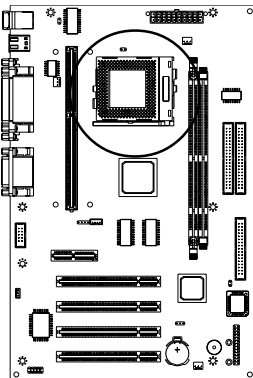

5. Function Illustrations

5.3. DIMM socket “DIMM1/2”

- DIMM socket is a 168-Pin unbuffered type socket that can install a 3.3V unbuffered SDRAM DIMM module.
- The M81-X series motherboard has two DIMM socket and maximum memory capacity is 256MB.
- For best performance, we recommend to use PC-100 DIMM module on the motherboard. If you install more than one module, the module should have different capacities, but the memory chips should be the same type and brand.

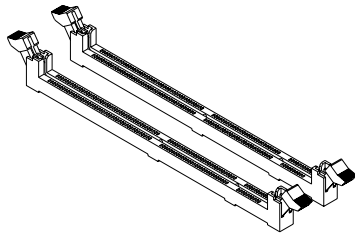
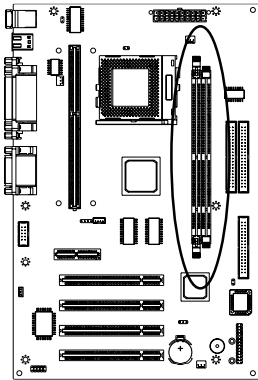

5.4. PCI slot “PCI1,2,3,4”

- It is a 120-Pin 32-bit expansion slot that accommodate all PCI peripherals and meet the PCI v2.2 specifications.
- The M81-X series motherboard has four PCI slots for your expansion cards.

Note : Follow the steps mentioned below to install the PCI interface card.

- Turn off your system power & remove the system case.
- Choose an unused PCI slot and remove the slot cover.
- Insert the interface card with the bottom edge to the slot. (Never insert the card at an angle). Check if your card is properly installed and refer to PCI card documentation regarding any additional requirement.
- Place the screw to fit the card.
- Before place your system case back, please check if you need to install any other card.
- Then place you system case back and make sure it is properly fixed by screw.

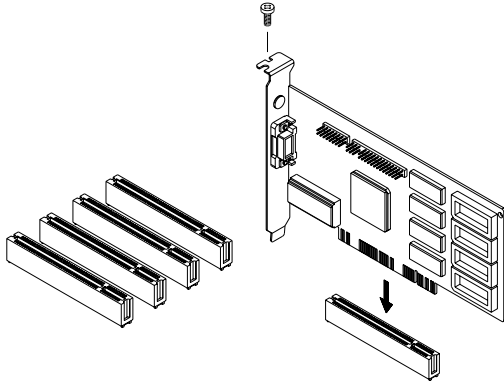
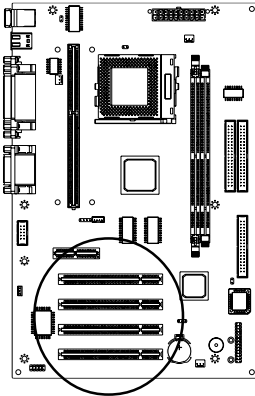

5.5. Audio Modem Riser Slot “AMR”

- It is a 46-Pin expansion slot that accommodate a specially designed Audio Modem Riser card called an AMR.
- Main processing is done through software and controller by motherboard’s I/O Controller Hub. This provides an upgrade able audio/modem solution at an incredibly low cost.

Note : Follow the steps mentioned below to install a AMR card.

- Please set jumper cap to the secondary position on the AMR interface card.
- Insert the AMR interface card with the bottom edge to the slot (Never insert the card at an angle). Check if your card is properly installed.
- Place the screw to fit the card.
- Refer to the AMR card’s documentation regarding any additional requirement.

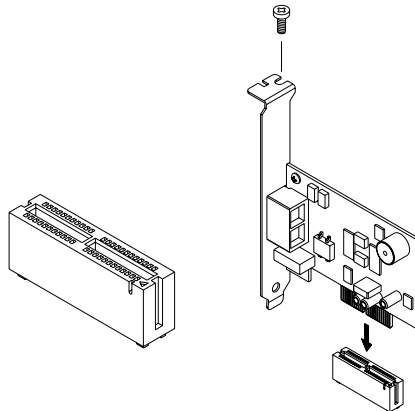
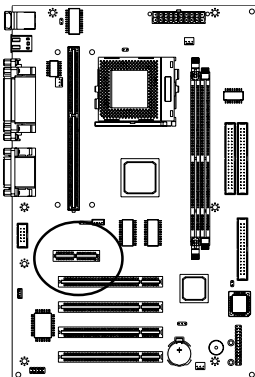

5. Function Illustrations

5.6. FDD Device Header “FDC”

- It is a 34-Pin box header that support up to two floppy disk drive devices of various sizes and densities.
- Floppy disk drive's priority is determined by the location of the drive on the cable. When install only one floppy disk drive you must connect it to the master position on the ribbon cable.

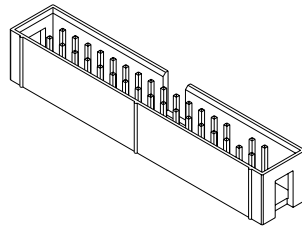
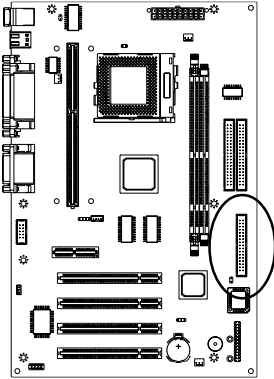

5.7. IDE Devices Header “IDE1,2”

- It is a 40-Pin box header that support standard ATAPI IDE devices.
- This is an dual channel IDE controller, a primary and a secondary. Each channel may support up to two ATAPI IDE devices.
- The primary channel has priority to the secondary channel. Within each channel, the two different devices are distinguished by master and slave relationship. The master device has priority over the slave device.
- When install more than one device in a channel you must set one a master and the other as its slave device. These device setting are usually determined by a jumper cap that is on the ATAPI IDE device.
- The M81-X and M81DC-X motherboard may supports both the Ultra DMA33 and Ultra DMA66 protocols. The M81L-X motherboard may only support Ultra DMA33 protocols.

Note : In order to achieve higher data transfer rate, please used a 40-Pin Ultra DMA66 IDE ribbon cable. Please be remember that only M81DC-X & M81-X Motherboard support Ultra DMA66 solution.

5. Function Illustrations

5.9. Serial Port Header "COM2"

- It is a 10-Pin box header that used for serial devices such as a mouse, fax/modem and so on.
- This serial port is identified by the system as COM2/4.

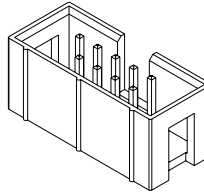
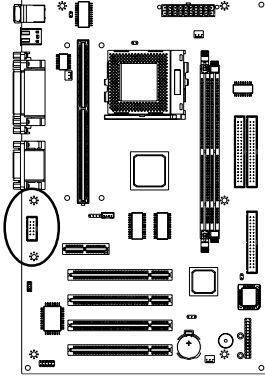

5.10. Battery "BAT1"

- It is a coin-cell style Lithium CR2032 battery is used to provide power to the RTC and CMOS memory.
- The battery has a three years life if the system is not powered up. When the system powers up, the power for the RTC and CMOS RAM is supplied from the 3.3V power supply to extend the life of battery.
- Replace if BIOS does not keep its settings.

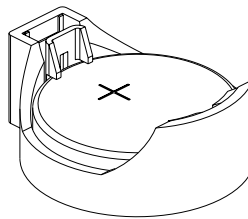
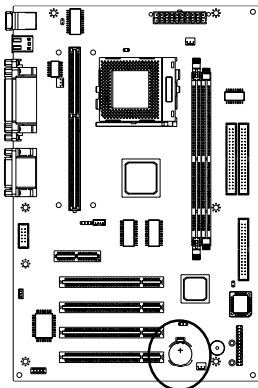

5.11. Buzzer “BZ1”

- It is a 5 volts onboard buzzer. When system has any abnormally state that you will hear warnings through buzzer.

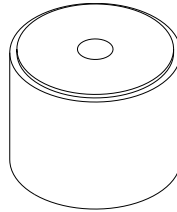
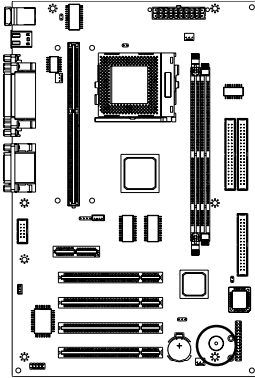

5.12. CUP / Power / Chassis Fan Connector “J1,J2,J11”

- These are 3-Pin connector that support cooling fan of 12 VDC/0.5A or less, when the system goes into sleep state, fan should be shut down to eliminate audible noise and reduce power consumption. You can monitor the fan speed by way of W83627HF chip and the fan must come with a tachometer output.
- The CPU and motherboard will overheat if there is no air flow across the CPU and onboard heat sink. Damage may occur to the motherboard and the CPU fan if these pins are incorrectly used.

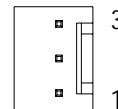
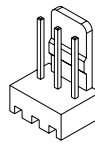
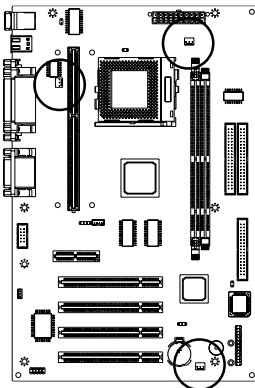

Pin	Assignment
1	GND
2	+12V
3	Speed/RPM

5. Function Illustrations

5.13. IrDA compliant IR Infrared Header “J12” (This item is optional)

- It is a 10-Pin Standard IR(SIR) and Consumer IR(CIR) headers. That support an optional wireless transmitting and receiving infrared module. This module mounts to a small opening on system case that support this feature.
- This is an optional item and it must be connected to the CIR and SIR header simultaneously for both wireless transmitting and remote control functions through one external infrared module.

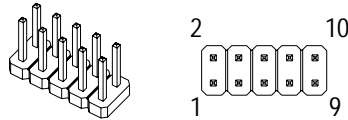
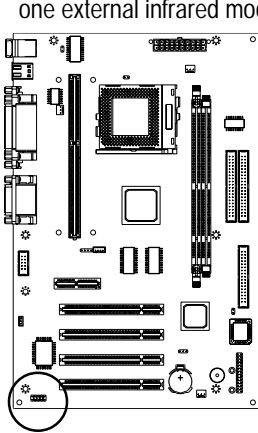

SIR		CIR	
Assignment	Pin	Pin	Assignment
+5V	1	2	NC
NC	3	4	CIRRx
IRRx	5	6	+5VSB
GND	7	8	NC
IRTx	9	10	NC

5.14. Wake On LAN Header “J10”

- It is a 3-Pin 2.0mm header that used for remote wake up of system through a network.
- This feature requires that Wake On LAN is set to Enable on the BIOS setup and your system has an ATX power supply with at least +5V standby/720mA power.

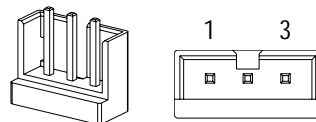
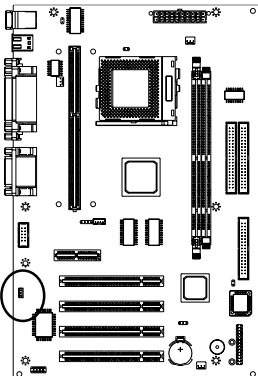

Pin	Assignment
1	Wake-Up Signal
2	GND
3	+5VSB

5.15. CMOS Memory Clear Header “JP3”

- It is a 3-Pin header that if your system can not boot-up because you forgot your password or the CMOS setting need to be reset to default values after the system BIOS has been updated.

The following instructions can be performed to clear the CMOS and password.

- Turn off your system power.
- Place a jumper cap to short Pin 2 and Pin 3 of JP1 for 3-5 seconds.
- Put the jumper cap back to Pin 1 and Pin 2 of JP1.
- Turn on your system power then access BIOS setup, please refer to BIOS configuration illustrations.

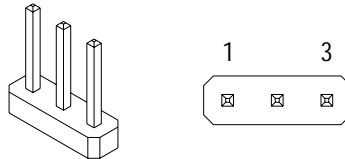
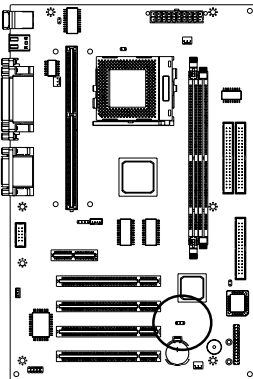

Jumper Cap	Function
Short Pin 1-2	Normal Operation
Short Pin 2-3	Clear CMOS

5.16. Flash BIOS Lock/Unlock “JP4” (This item is optional)

- It is a 2-Pin header that support Flash BIOS Lock/Unlock function.
- Flash BIOS is stored on an Erasable Programmable Read Only Memory (EPROM) chip. This means that you can erase the current BIOS and flashing a new BIOS, you must set JP4 to Unlock. After the new BIOS is installed, set JP4 to Lock so that the BIOS cannot be erased by accident.

5. Function Illustrations

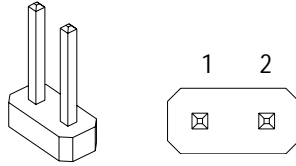
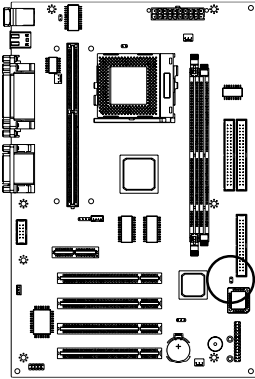

Jumper Cap	Function
Open Pin 1-2	Lock Flash BIOS
Short Pin 1-2	Unlock Flash BIOS

5.17. CD-In Header “J7,J8”

- CD-in J7 is a 4-Pin 2.54mm audio header which can be used to input the audio from a CD-ROM or DVD drive.
- CD-in J8 4-Pin 2.0mm header is exactly the same, except that it support an alternative kind of connector. Use either J7 or J8 to connect your CD-ROM or DVD drive audio output.

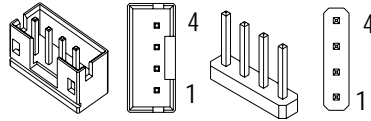
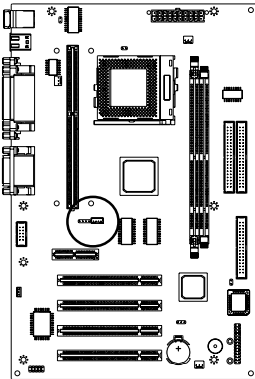

Pin	Assignment	
	J7	J8
1	CD-L	GND
2	GND	CD-L
3	GND	GND
4	CD-R	CD-R

5.18. Keyboard and Mouse Power on Header “JP1”

- JP1 is a 2-Pin header which can be used to power on function. Allows you to power on the system by pressing hot keys, or typing a password. If you choose password, you can set the password in the BIOS (Power On) function of (Integrate Peripheral) screen to install a power on password. If you set it to (Hot Key), then you can use the item (Hot Key) power on to choose which hot keys are installed.

- Or allows you to power on the system by double click **(Right Key)** or **(Left Key)** of mouse for wake up your system from sleep state.

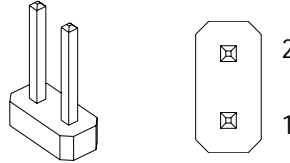
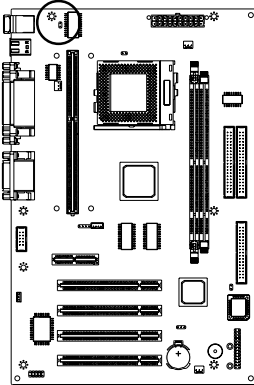

Jumper Cap	Function
Short Pin 1-2	Wake-up Enable
Open Pin 1-2	Wake-up Disable

5.19. Processor Type Setting Header “JP2”

- It is a 2-Pin header that used for Processor type setting.
- JP2 Pin1-2 shorted by a jumper cap that supported for Slot1 Processors.
- JP2 Pin1-2 opened (or placed on just a single pin) that supported for PPGA370 Processors.

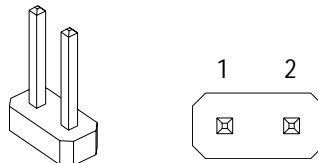
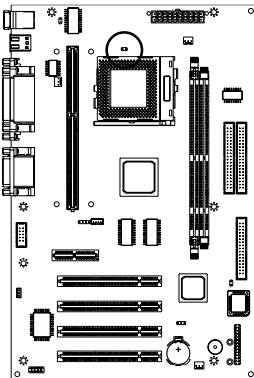

Jumper Cap	Function
Short Pin 1-2	Support Slot1
Open Pin 1-2	Support PP GA370

5.20. Power Connector “ATX1”

- It has a single lead connector with a clip on one side of the plastic housing. There is only one way to plug the lead into the power connector “ATX1”. Press the lead connector down until the clip snaps into place and secures the lead on to the connector.

5. Function Illustrations

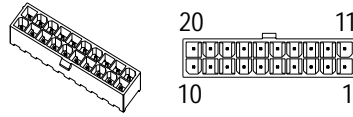
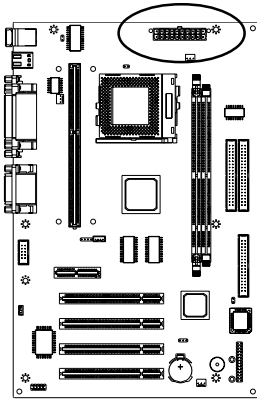

Assignment	Pin	Pin	Assignment
+3.3V	11	1	+3.3V
-12V	12	2	+3.3V
GND	13	3	GND
PW ON/OFF	14	4	+5V
GND	15	5	GND
GND	16	6	+5V
GND	17	7	GND
-5V	18	8	PW-GOOD
+5V	19	9	+5VSB
+5V	20	10	+12V

5.21. Back Panel I/O Connectors “PS/2, USB, LPT, COM1, VGA1, Game_Audio”

The back panel provides external access to PS/2 style Keyboard and Mouse port, one Serial port, one AGP display port, one Parallel port dual USB port and one Game_Audio port, which are integrated on the motherboard for PC99 specification.

- PS/2 is a dual mini DIN ports. The upper port can be used by a PS/2 Mouse or Pointing device. The lower port can be used by a PS/2 Keyboard.
- USB is a dual Universal Serial Bus ports. Use these ports to connect to USB devices (USB Mouse, Keyboard, Scanner, Modem, etc).
- LPT is a highrise Parallel port that can be used by Printers or other Parallel Communication devices.
- COM1 is a Serial port that can be used by Serial devices such as a Mouse, External Modem, Drawing Tablet, Plotter, etc.
- VGA1 is a AGP display port for output to a Monitor device.
- Game_Audio is dual port for Game_MIDI, Line-Out, Line-In, Microphone. The upper is a Game_MIDI port that can be used by a Joystick controller or a MIDI device. The lower is three 1/8" Audio jack. The left side jack is for a stereo Line-Out signal to Speaker device. The middle jack is for a stereo Line-In signal to Audio Input device. The right side jack is for stereo Microphone.

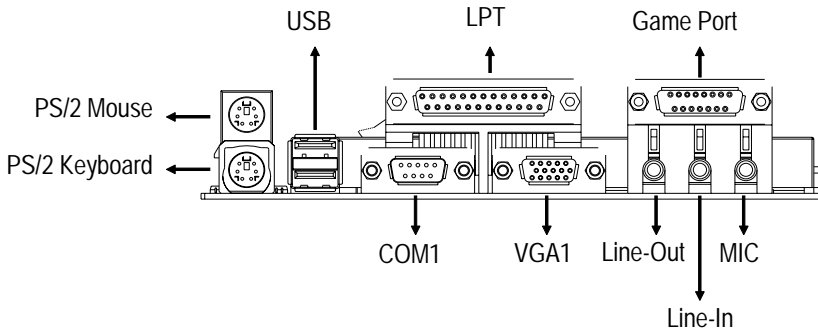
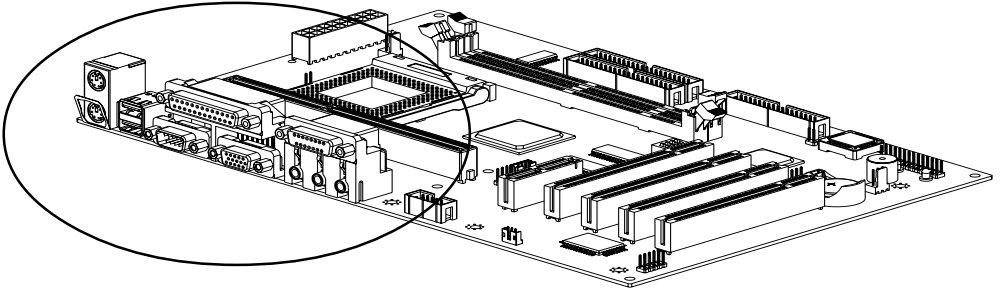

6. Hardware Installation

6. Hardware Installation

6.1 Before you Begin

The M81-X series motherboard is designed to fit into a standard ATX form factor chassis. The pattern of the mounting holes and the position of back panel I/O ports meet the ATX motherboard specification. The chassis may come with various mounting fasteners which are made of metal or plastic. It is highly recommended to use as many metal fasteners as possible to mount the motherboard in the chassis for better grounding.

6.2 Caution Static Electricity

Before removing the motherboard from its anti-static bag, you need to eliminate any static electricity that may be accumulated on your body by touching a grounded or anti-static surface. If noting is available, touch the housing of power supply which is plugged into the AC outlet.

After removing the motherboard from its anti-static bag, place it only on a grounded or anti-static surface, component side up. Inspect the motherboard and contact your retailer immediately if it is damaged.

6.3 Installation Guide

We will now begin the installation of motherboard. Please follow the procedure step-by-step which designed to guide you to a complete and correct installation.

Step1: Install the PPGA370 Processor (If you are install PPGA370 Processor, please refer to it for your require)

- Locate the Pin-1 on the Processor and PGA370 socket, then open the locking lever for Processor
- Orient the Processor and insert vertically on to the socket until the Processor clip into place.

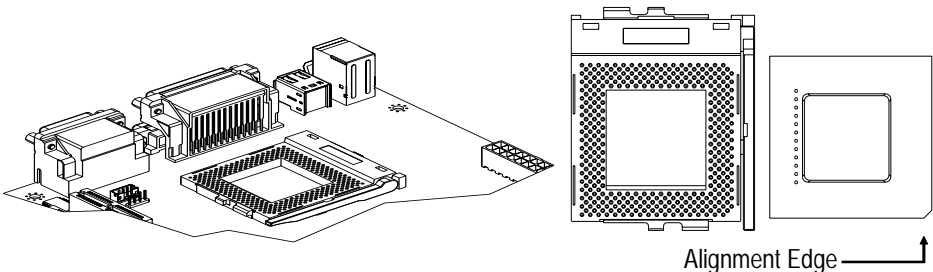

- Turn the swivel to locking position and hook it under the latch on the side of the socket to lock it in place.
- Orient the cooling fan and heat sink then insert firmly.

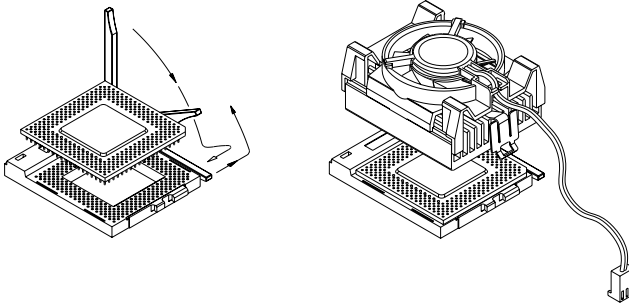

- Locate the power connector J1 for the Processor cooling fan, then connect the cable from cooling fan to J1.

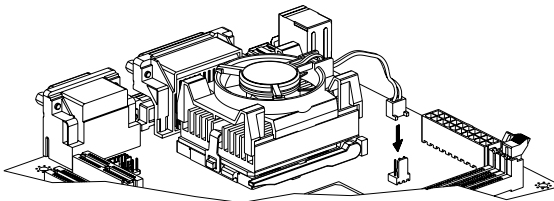

Step1: Install the Slot1 Processor (If you install Slot1 Processor, please refer to it for your require)

- Open the EAR of Universal Retention Module.
- Remove the sliders to "OPEN" position.
- Orient the Slot1 Processor and insert vertically on to the slot until the Processor clip into place.
- Remove the sliders of the URM to "LOCK" position.

Note : Removing the Processor procedure.

- Disconnect the fan power cable from the motherboard.
- Remove the sliders of the URM to "OPEN" position.
- Push the latches on the Processor toward the center of the Processor until they click into place.
- Lift one end of the Processor until it is freed from Slot1. Lift the other end of

6. Hardware Installation

the Processor until it is freed from Slot1. Lift the entire Processor until it is freed from the URM.

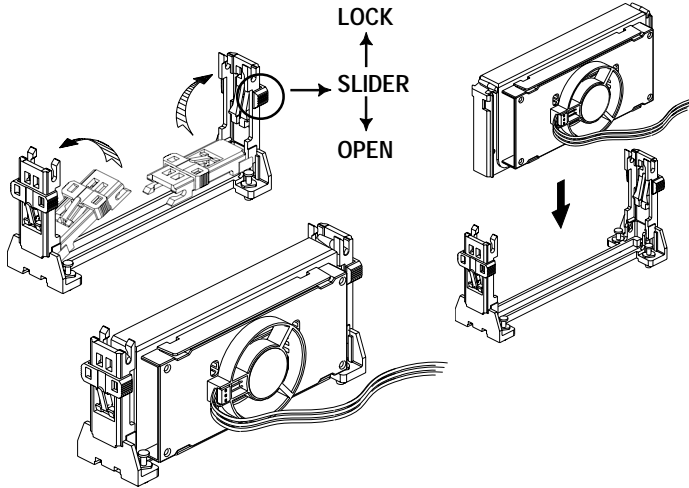

- Locate the power connector J1 for the Processor cooling fan, then connect the cable from cooling fan to J1.

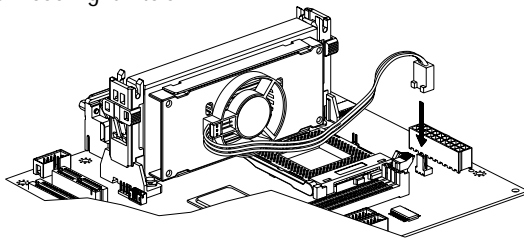

Warning : Processors require a heat sink with a cooling fan. Failure to provide adequate cooling of the Processor may seriously affect system performance or cause permanent damage to the Processor.

Step2: Use the screws and mounting brackets supplied with you chassis to install the motherboard. Whenever possible, refer to the manufacturer's instructions.

Step3: Install the DIMM Modules

- Locate the DIMM socket on the motherboard, then open the locking levers on the DIMM socket.
- Align the DIMM to the socket, then install the DIMM module into the socket and press it carefully but firmly down 90 degrees on to the socket until the arms lock.

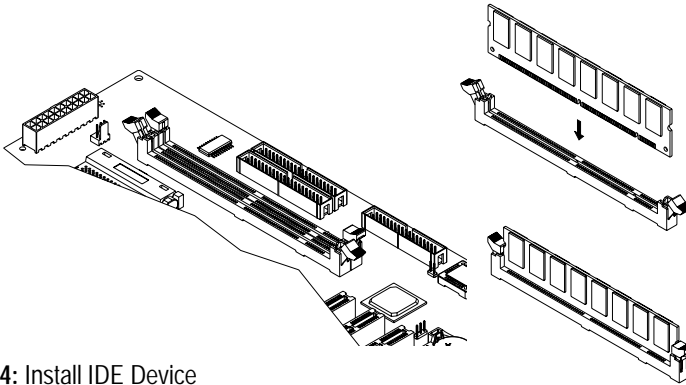

Step4: Install IDE Device

- Locate the IDE1 and IDE2 box header on the motherboard.
- IDE1-Connect one end of the 40-Pin ribbon cable that comes with the drive to the HDD header, and the other end of the cable to the IDE1 box header on the motherboard.
- IDE2-Connect one end of the 40-Pin ribbon cable that comes with the drive to the CD-ROM header, and the other end of the cable to the IDE2 box header on the motherboard. (Note : Each header has the Pin-1 side clearly marked. The Pin-1 side of the each ribbon cable is always marked with a red stripe on the cable.)

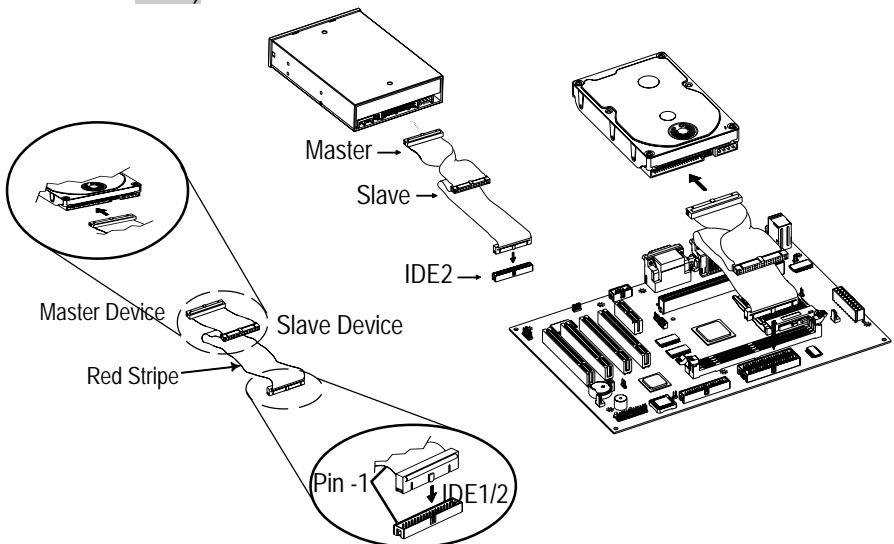

6. Hardware Installation

- The primary channel has priority to the secondary channel. Within each channel, the two different devices are distinguished by master and slave relationship. The master device has priority over the slave device. (Refer to illustration on the below)

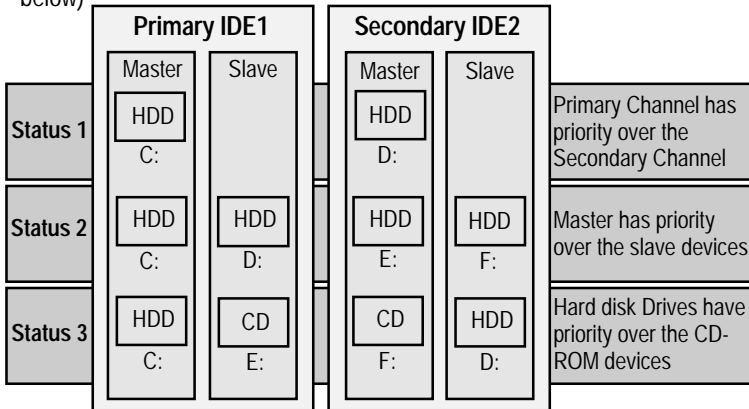

Step5: Install FDD Device

- Locate the FDC box header on the motherboard.
- FDC-Connect one end of the 34-Pin ribbon cable that come with the drive to the FDD header, and the other end of the cable to the FDC box header on the motherboard. (Note: Each header has the Pin-1 side clearly marked. The Pin-1 side of the each ribbon cable is always marked with a red stripe on the cable.)

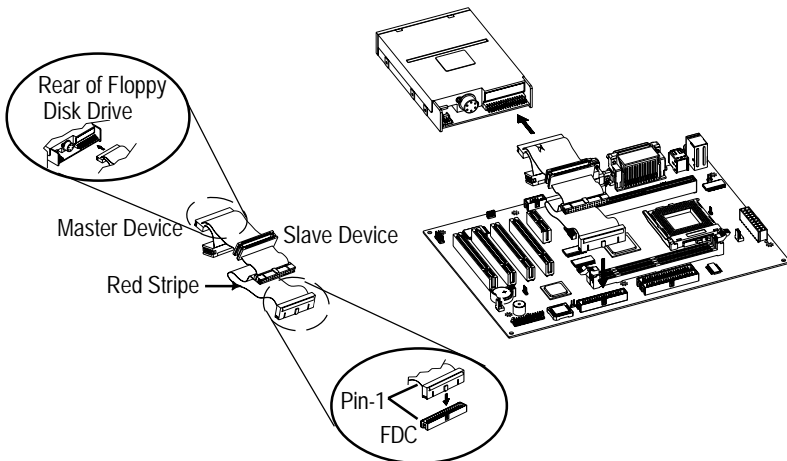

Step6: Front Panel I/O Connections

- Follow the instruction carefully for proper connections to your front panel display and control.
- Power SW →Reset SW →HDD LED→Power LED→Key Lock.
(If you have a speaker on the chassis that we recommend not to use them because it will have buzzer noise when the system is booted.)

Step7: ATX1 / HDD / FDD Power Connection

- Connect ATXPWR of the power supply unit to the ATX1 connector on the motherboard.
- Connect HDDPWR of the power supply unit to the power connector on the HDD device.
- Connect FDDPWR of the power supply unit to the power connector on the FDD device.

Note : Incorrect installation of the power supply could result in serious damage to the motherboard and connected peripherals. Make sure the power supply is unplugged from the AC outlet before connecting the leads from the power supply.

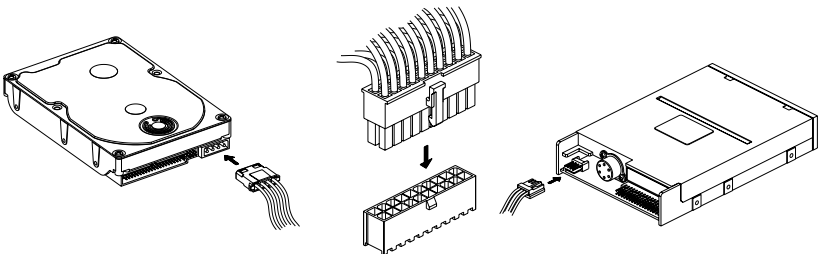

Step8: Back I/O Connections

- Follow the instruction carefully for proper connection I/O peripherals to your system.
- Keyboard→Mouse→Monitor→AC power cord.

Step9: Boot the system

- You are now ready to boot the system for the first time. Please continue to the next section to configure your BIOS (Basic Input Output System) setting. It must be configured after booting.

7. BIOS Configuration

7. BIOS Configuration

The motherboard provides a 4MB, 3.3V, 32-Pin PLCC package Firmware Hub chips that can be updated using provided BIOS Utility. The Setup Utility stores data about motherboard components and the configuration of devices that are connected to it. The information is used to test and initialize components at start up time and to make sure everything runs properly when the system is operating. The Utility provide you the opportunity whenever you need to install your motherboard, change its default value for better performance or reconfigure your system when new components or device are used. We will suggest updating your BIOS if you have problems with your motherboard and you know that the new BIOS revision will solve your problems. Unnecessary updating may result more problems for your motherboard.

When you start up the system, the system provides the opportunity to run this program. This appears during the Power On Self Test (POST), press <DELETE> key to call up "Setup Utility". If you are a little bit late pressing the mentioned key(s), POST will continue with its test routines. If you still need to call setup, restart the system by pressing <Ctrl> + <Alt> + <Delete> keys, or press the reset button on your chassis.

You can also restart by turning system off and then back on again. But do it only first 2 way fail. The below table, CMOS SETUP UTILITY will appear on screen after call up.

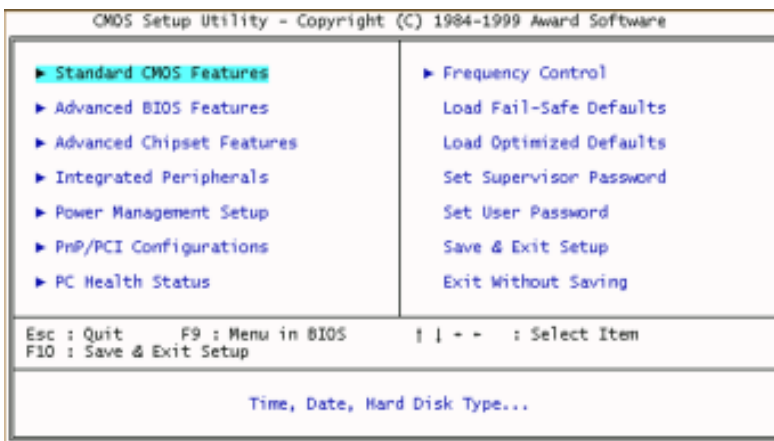

At the bottom of the setup screen you will notice a legend bar. The keys in the legend bar allow you to navigate through the various setup menus. The following table lists shown you the keys found in the legend bar with their corresponding alternates and functions.

Navigation Key(s)	Function Description
<F1>	Displays the General Help screen from anywhere in the BIOS setup.
<Esc>	Jumps to the EXIT menu or returns to the main menu from a sub-menu
← or → (Keypad arrow)	Selects the menu item to the left or right
↑ or ↓ (Keypad arrow)	Moves the highlight up or down between fields
- (Minus key)	Scrolls backward through the values for the highlighted field
+ (Plus key)	Scrolls forward through the values for the highlighted field
<Enter>	Brings up a selection menu for the highlighted field
<Home> or <PgUp>	Moves the cursor to the first field
<End> or <PgDn>	Moves the cursor to the last field
<F5>	Load previous values from CMOS
<F6>	Load the fail-safe defaults from BIOS default table
<F7>	Load the optimized defaults
<F10>	Save all the CMOS changes and exit

When you start setup, the main menu appears. The main menu of the setup Utility shows a list of the options that are available. A highlight shows which option is currently selected. You can use the cursor arrow <↑><↓><←><→> keys to move the highlight to other options. When an option is highlighted, you can execute the option by pressing the <Enter> key.

Some option lead to tables of items that usually have a value on the right side. The value of the first item is highlighted, and you can use the cursor arrow keys to select any of the other values in the table of items. When an item is highlighted, you can change the value by pressing the <PgUp> <PgDn> or <-> <+> keys. The <PgUp> and <+> keys cycle forward through the available values the <PgDn> and <-> keys cycle backward through the available values.

When you are in an option that displays a table of items, you can return to the main menu by pressing the <Esc> key. For some items, you can display a general help screen by pressing the <F1> key. Press the <F5> key to discard any changes you have made and return all items to the value that they held when the setup Utility was started. Press the <F6> key to load the displayed item with a standard list of fail-safe value. Press the <F7> key to load the displayed items with a high performance list of default values.

7. BIOS Configuration

7.1 Standard CMOS Features

Selecting “**Standard CMOS Features**” on the main program screen display this menu :

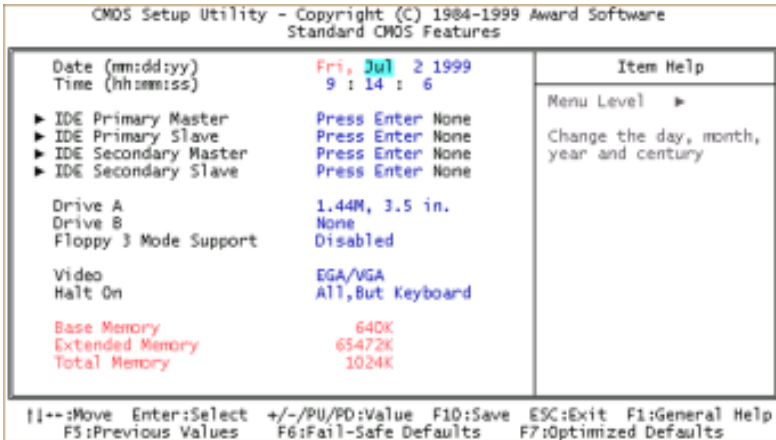

User configured fields appear in a different color. If you need information on selected field, Press the <F1> key. The help menu will appear to provide you with the information you need. The memory display at the lower side of the screen is read-only and automatically adjusts accordingly.

7.1.1 Date and Time Setting

Date : To set the date, highlight the “Date” field and then press the <PgUp> / <PgDn> or <+> / <-> keys to set the current date. Follow the month, day and year format. Valid values for month, day and year are :

Month : **1** to **12**

Day : **1** to **31**

Year : up to **2079**

Time : To set the time, highlight the <Time> field and then press the <PgUp> / <PgDn> or <+> / <-> keys to set the current time. Follow the hour, minute and second format. Valid values for hour, minute and second are :

Hour : **00** to **23**

Minute : **00** to **59**

Second : **00** to **59**

You can pass the date and time prompts by creating an AUTOEXE.BAT file. For information on how to create this file, please refer to a MS-DOS manual.

7.1.2 IDE HDD Disks [Auto]

Selecting “IDE Primary Master” on the Standard CMOS Features screen display this menu:

CMOS Setup Utility - Copyright (C) 1984-1999 Award Software		Item Help
IDE Primary Master		
IDE HDD Auto-Detection	Press Enter	
IDE Primary Master	Auto	Menu Level >>
Access Mode	Auto	To auto-detect the HDD's size, head... on this channel
Capacity	5763 MB	
Cylinder	11166	
Head	16	
Precomp	65535	
Landing Zone	11165	
Sector	63	

[[--:Move Enter:Select +/-/PU/PD:Value F10:Save ESC:Exit F1:General Help
F3:Previous Values F6:Fail-Safe Defaults F7:Optimized Defaults

Press <Enter> key to automatically detect an IDE hard disk drive. If automatic detection is successful, the correct values will be filled in the remaining fields on this screen. Displayed up are explanation of the Maxtor Diamond 5.7GB HDD.

- If automatic detection fails, your hard disk drive may be to older too, now. You can try updating your BIOS or enter the correct parameters manually. Press the <PgUp> or <PgDn> key to [Manual] mode on the IDE Primary Master screen. Manually enter Access Mode, number of Cylinder, Head, Precomp, Landing Zone and Sector for your drive. Refer to your drive documentation or look on the drive for this information. If no drive is installed or you are removing a drive away, select [None] mode.
- The **Access Mode** entry is for IDE hard disks only, and can be ignored for MFM and ESDI drive. This entry provides four options : [Auto] [Normal] [LBA] [Large]. Set access mode to the [Normal] for IDE hard disk drive smaller than 528MB. Set it to [LBA] for drive over 528MB that support Logical Block Addressing (LBA) to allow large IDE hard disk drive. Set it to [Large] for drive over 528MB that do not support LBA. [Large] type of drive can only be used with MS-DOS and is very uncommon. Most IDE drive over 528MB support the [LBA] mode.
- After the IDE hard disk drive information has been entered into BIOS, new IDE

7. BIOS Configuration

hard disk drive must be partitioned (such as with FDISK.EXE), please refer to a MS-DOS manual and then formatted before data can be read from and write on Primary IDE hard disk drive must have its partition set to active (also possible with FDISK.EXE).

The available options for IDE HDD Auto-Detection are : [Press Enter].

The available options for IDE Primary Master are : [Auto] [Manual] [None].

The available options for Access Mode are : [Auto] [Normal] [LBA] [Large].

7.1.3 Drive A / Drive B / Floppy 3 Mode Support **[1.44M, 3.5 in]/[None]/[Disabled]**

These items set the type of floppy disk drive in your system.

- The available options for Drive A and B are : [1.44M, 3.5 in] [2.88M, 3.5 in] [None] [360K, 5.25 in] [1.2M, 5.25 in] [720K, 3.5 in].
- The available options for Floppy 3 Mode Support are : [Disabled] [Drive A] [Drive B] [Both] . This is the Japanese standard floppy drive which stores 1.2MB in a 3.5" diskette.

7.1.4 Video **[EGA/VGA]**

This item set the Video mode of the system. This motherboard has a built-in VGA graphics circuit so you must leave this item at the default value.

- **[EGA/VGA]** : Enhanced Graphics Adapter/Video Graphics Array. For EGA, VGA, SVGA, or PGA monitor adapters.
- **[CGA 40]** : Color Graphics Adapter, power up in 40 column mode.
- **[CGA 80]** : Color Graphics Adapter, power up in 80 column mode.
- **[MONO]** : Monochrome adapter, includes high resolution monochrome adapters.

The available options for Video are : [EGA/VGA] [CGA 40] [CGA 80] [MONO].

7.1.5 Halt On **[All, But Keyboard]**

This item set whether the system will stop If an error is detected during POST (Power On Self Test) routine.

- **[All, But Keyboard]** : The system boot will not stop for a keyboard error; it will stop for all other errors.
- **[All, But Diskette]** : The system boot will not stop for a disk error; it will stop for all other errors.
- **[All, But Disk/Key]** : The system boot will not stop for a keyboard or disk error; it will stop for all other errors.

- **[All Errors]** : Whenever the BIOS detects a non-fatal error the system will be stopped.
- **[No Errors]** : The system boot will not stop for any error that may be detected and you will be prompted.

The available options for Halt On are : [All, But Keyboard] [All, But Diskette] [All, But Disk/Key] [All Errors] [No Errors].

7.1.6 Base Memory, Extended Memory, Total Memory

These item are display-only which is determine by POST of the BIOS.

- **[Base Memory]** : Display the amount of conventional memory detected during boot up.
- **[Extended Memory]** : Display the amount of extended memory detected during boot up.
- **[Total Memory]** : Display the total memory available in the system.

After you have made your selection(s) in the Standard CMOS Features, press the <Esc> key to go back to main program screen.

7. BIOS Configuration

7.2 Advanced BIOS Features

Selecting “Advanced BIOS Features” on the main program screen display this menu :

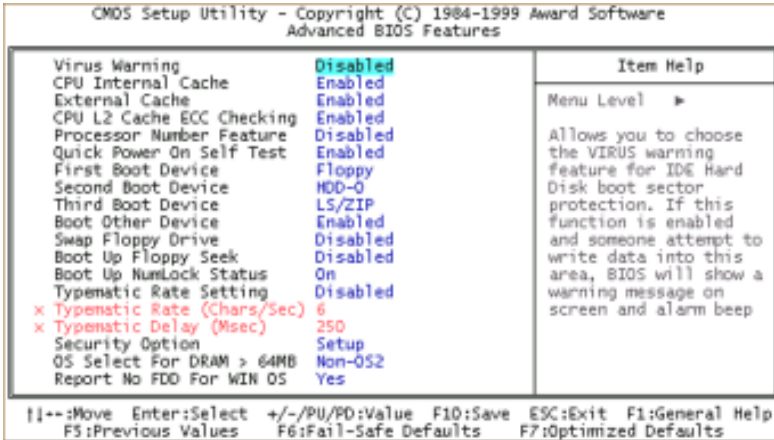

This feature allows you to set the various system options of your choice, including virus warning, external cache, security option and boot operations. To access the Advanced BIOS Features screen, highlight this option on the main menu screen and press <Enter> key.

7.2.1 Virus Warning [Disabled]

If this item is enabled, it provides some protection which try to write to the boot sector and partition table of your hard disk drive. We recommend that you enabled virus warning as soon as you have installed your disk with an OS. When enabled a warning message is displayed and a beep sound is produced whenever an attempt is made to write on the hard disk's boot sector.

The available options for Virus Warning are : [Disabled] [Enabled].

7.2.2 CPU Internal Cache/External Cache [Enabled]/[Enabled]

These item enabled or disabled the cache of your system. The cache feature enhances system performance because the most frequently used data is accessed from and written to the high-speed cache memory.

The available options for CPU Internal Cache and External Cache are : [Enabled] [Disabled].

7.2.3 CPU L2 Cache ECC Checking [Enabled]

When this item is enabled, it allows the system to carry out cache memory error checking if the cache memory chips support ECC (Error Checking and Correction).
The available options for CPU L2 Cache ECC Checking are : [Enabled] [Disabled].

7.2.4 Processor Number Feature [Disabled]

If you have installed Pentium III processor on the motherboard and enabled this item. It will provides a processor serial number for your system certify.
The available options for Processor Number Feature are : [Disabled] [Enabled].

7.2.5 Quick Power On Self Test [Enabled]

This will skip some diagnostic checks during the Power On Self Test (POST) to speed up the booting process.
The available options for Quick Power On Self Test are : [Enabled] [Disabled].

7.2.6 First/Second/Third Boot Device [Floppy]/[HDD-0]/[LS/ZIP]

These items to setting the priority and sequence the devices that your system will search for an operating device during bootup.
The available options for First/Second/Third Boot Device are : [Floppy] [LS/ZIP] [HDD-0] [HDD-1] [HDD-2] [HDD-3] [SCSI] [CDROM] [LAN] [Disabled].

7.2.7 Boot Other Device [Enabled]

If you enable this item, the system will search all other possible locations for an operating device it fails to find one in the devices specified under First, Second and Third Boot Devices.
The available options for Boot Other Device are : [Enabled] [Disabled].

7.2.8 Swap Floppy Drive [Disabled]

If you have two floppy drive in your system, this item allows you to swap around the assigned drive letters so that drive A become drive B, and drive B become drive A.
The available options for Swap Floppy Drive are : [Disabled] [Enabled].

7.2.9 Boot Up Floppy Seek [Disabled]

If this item is enable, it checks the geometry of the floppy drive at start up time.
The available options for Boot Up Floppy Seek are : [Disabled] [Enabled].

7.2.10 Boot Up NumLock Status [On]

This item defines if the keyboard <NumLock> key is active when your system is bootup.
The available options for Boot Up NumLock Status are : [On] [Off].

7. BIOS Configuration

7.2.11 Typematic Rate Setting [Disabled]

Typematic Rate (Chars/Sec) [6]

Typematic Delay (Msce) [250]

This setting allows you to select which key strokes repeat at a rate determined by the keyboard controller. When Enabled , the typematic rate and typematic delay can be selected. You can use Typematic Rate (Chars/Sec) to define how many characters per second are generated by a held-down key. And use Typematic Delay (Msec) to define how many milliseconds must elapse before a held-down key begins generating repeat characters.

The available options for Typematic Rate Setting are : [Disabled] [Enabled].

The available options for Typematic Rate (Chars/Sec) are : [6] [8] [10] [12] [15] [20] [24] [30].

The available options for Typematic Delay (Msec) are : [250] [500] [750] [1000].

7.2.12 Security Option [Setup]

This item allows you to limit access to the system and setup, or just to setup.

- **[Setup]** : The system will boot, but access to setup will be denied if the correct password is not entered at the prompt.
- **[System]** : The system can not boot and can not access to setup page will be denied if the correct password not entered at the prompt.

Note : Security takes effect only if a password is set. (See set Supervisor/User Password in this chapter.)

The available options for Security Option are : [Setup] [System].

7.2.13 OS Select For DRAM > 64MB [Non-OS2]

This item is only required if you have installed more than 64MB of memory and running the OS/2 operating system. Otherwise, leave this item at the default [Non-OS2].

The available options for OS Select For DRAM > 64MB are : [Non-OS2] [OS2].

7.2.14 Report No FDD For WIN OS [Yes]

This setting controls whether report no FDD for WIN OS or not.

The available options for Report No FDD For WIN OS are : [Yes] [No].

After you have made your selection(s) in the Advanced BIOS Features, press the <Esc> key to go back to the main program screen.

7.3 Advanced Chipset Features

Selecting “Advanced Chipset Features” on the main program screen display this menu :

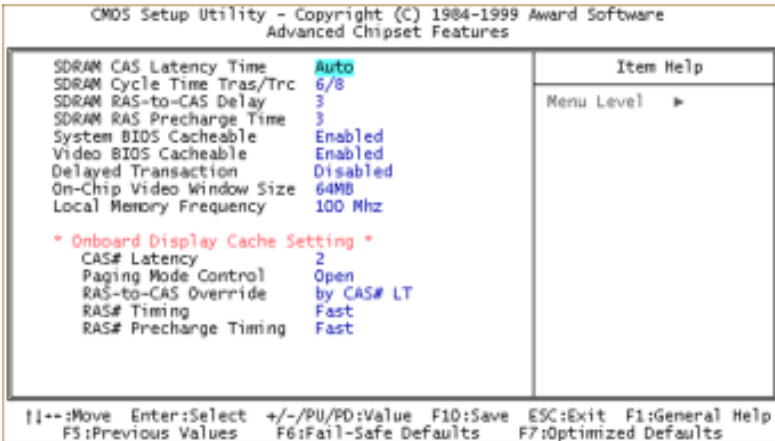

To access the Advanced Chipset Features screen that define critical timing parameters of the motherboard components. Generally, you should leave the item on this feature at their default values unless you are very familiar with the technical specification of your system hardware. If you change the values incorrectly you may introduce fatal and instability into your system. Highlight this option on the main menu screen and press <Enter> key.

7.3.1 SDRAM CAS Latency Time **[Auto]**

SDRAM RAS-to-CAS Delay **[3]**

SDRAM RAS Precharge Time **[3]**

These items set the timing of the Column Address Strobe and Row Address Strobe for SDRAM. We recommend that you leave these items at the default. Slower rate [3] may be required for slower SDRAMs or more than 2 banks of SDRAM DIMMs are installed.

The available options for SDRAM CAS Latency Time are : [Auto] [2] [3].

The available options for SDRAM RAS-to-CAS Delay and SDRAM RAS Precharge Time are : [3] [2].

7.3.2 SDRAM Cycle Time Tras/Trc **[6/8]**

This setting controls the number of SDRAM clock used per access cycle.

The available options for SDRAM Cycle Time Tras/Trc are : [6/8] [5/7].

7.3.3 System BIOS Cacheable **[Enabled]**

7. BIOS Configuration

Video BIOS Cacheable **[Enabled]**

These items allow the System BIOS and Video BIOS to be cached in memory for faster performance. We recommend that you leave these item at the default values. The available options for System and Video BIOS Cacheable are : [Enabled] [Disabled].

7.3.4 Delayed Transaction **[Disabled]**

The chipset has an embedded 32-bit write buffer to support delay transactions cycles. The available options for Delayed Transaction are : [Disabled] [Enabled].

7.3.5 On-Chip Video Window size **[64MB]**

This option determines the effective size of the AGP graphic aperture, which memory-mapped graphic data structures can reside in.

The available options for On-Chip Video Windows Size are : [64MB] [32MB] [Disabled].

7.3.6 Onboard Display Cache Setting

CAS# Latency **[2]**

Paging Mode Control **[Open]**

RAS-to-CAS Override **[by CAS#LT]**

RAS# Timing **[Fast]**

RAS# Precharge Timing **[Fast]**

These items under this Onboard Display Cache Setting are used to set the parameters for display cache memory which may be optionally installed on the M81DC-X motherboard, we recommend that you leave these items at the default setting.

The available options for CAS# Latency are : [2] [3].

The available options for Paging Mode Control are : [Open] [Close].

The available options for RAS-to -CAS Override are : [by CAS# LT] [Override (2)].

The available options for RAS# Timing are : [Fast] [Slow].

The available options for RAS# Precharge are : [Fast] [Slow].

After you have made your selection(s) in the Advanced Chipset Features, press the <Esc> key to go back to the main program screen.

7.4 Integrated Peripherals

Selecting “Integrated Peripherals” on the main program screen display this menu :

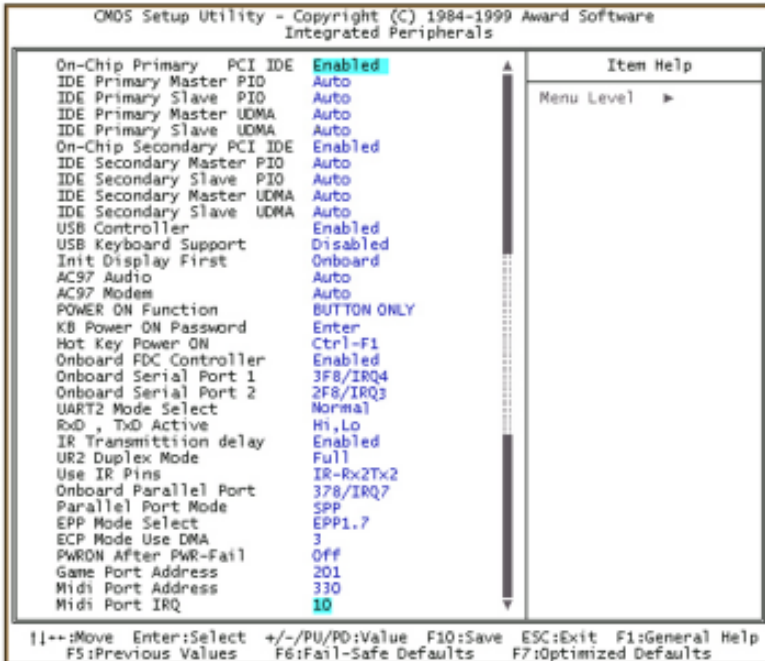

This option displays a list of items which defines the operation of some. Peripheral items on the systems input/output ports. To access the Integrated Peripherals screen, highlight this option on the main menu screen and press <Enter> key.

7.4.1 On-Chip Primary PCI IDE [Enabled]

IDE Primary Master/Slave PIO [Auto]/[Auto]

IDE Primary Master/Slave UDMA [Auto]/[Auto]

On-Chip Secondary PCI IDE [Enabled]

IDE Secondary Master/Slave PIO [Auto]/[Auto]

IDE Secondary Master/Slave UDMA [Auto]/[Auto]

- On-Chip Primary/Secondary PCI IDE these items allows you to Enabled or Disabled the Primary and Secondary PCI IDE channels that are integrated on the system.

The available options for On-Chip Primary/Secondary PCI IDE are : [Enabled]
[Disabled].

7. BIOS Configuration

- IDE Primary Master/Slave PIO and IDE Secondary Master/Slave PIO these four items let you assign which kind of PIO (Programmed Input/Output) is used by IDE devices. You can choose Auto, to let the system auto detect which PIO mode is best, or you can install a PIO mode from 0-4. Each IDE channel supports a master device and slave device.

The available options for IDE Primary Master/Slave PIO and IDE Secondary Master/Slave PIO are : [Auto] [Mode 0] [Mode 1] [Mode 2] [Mode 3] [Mode 4].

- IDE Primary Master/Slave UDMA and IDE Secondary Master/Slave UDMA. When set to Auto the BIOS will automatically load UltraDMA (UltraDMA technology provides faster access to IDE devices) drive to match the transfer rate of IDE hard drive which supports UltraDMA devices.

The available options for IDE Primary Master/Slave UDMA and IDE Secondary Master/Slave UDMA are : [Auto] [Disabled].

7.4.2 USB Controller [Enabled]

USB Keyboard Support [Disabled]

This setting allow you to enabled the USB ports that are integrated on the motherboard. And if you are using a keyboard connected through the USB port.

The available options for USB Controller are : [Enabled] [Disabled].

The available options for USB Keyboard Support are : [Disabled] [Enabled].

7.4.3 Init Display First [Onboard]

This item to define if your graphics adapter is installed in one of the PCI slots or select Onboard if you have a graphics system integrated on the motherboard.

The available options for Init Display First are : [Onboard] [PCI Slot].

7.4.4 AC97 Audio [Auto]

AC97 Modem [Auto]

These items allows you to decide to Enabled or Disabled the i810 chips family to support AC97 Audio and Modem. We recommend that you set these items to enabled when you use an AMR card.

The available options for AC97 Audio and AC97 Modem are : [Auto] [Disabled].

7.4.5 POWER ON Function [BUTTON ONLY]

KB Power ON Password [Enter]

Hot Key Power ON [Ctrl-F1]

The POWER ON Function item allows you to power on the system by pressing hot keys or typing a password. Refer to explain in the below.

- **[Password]** : Disable the function of power button and let the system can only be powered on through the preset keys (like a password).
- **[BUTTON ONLY]** : Disable Wake on Keyboard an Mouse function. You can boot up your system by power button only.
- **[Keyboard 98]** : You can boot up the system by wake up button on keyboard 98.
- **[Any KEY]** : This function allows you power on the system by clicking any key.
- **[Mouse Left]** : This function allows you power on the system by double click on mouse's left button.
- **[Mouse Right]** : This function allows you power on the system by double click on mouse's right button.
- **[Hot KEY]** : This function allows you power on the system by pressing function key <Ctrl> + <F1> through <Ctrl> + <F12> on keyboard.

The available options for POWER ON Function are : [BUTTON ONLY] [Keyboard 98] [Password] [Hot KEY] [Mouse Left] [Mouse Right] [Any KEY].

The available options for KB Power ON Password are : [Enter].

The available options for Hot Key Power ON are : [Ctrl-F1]~[Ctrl-F12].

7.4.6 Onboard FDC Controller **[Enabled]**

This item to turn on or turn off the floppy disk controller that is built into the motherboard.

The available options for Onboard FDC Controller are : [Enabled] [Disabled].

7.4.7 Onboard Serial Port 1 **[3F8/IRQ4]**

Onboard Serial Port 2 **[2F8/IRQ3]**

These options are used to assign an I/O address and Interrupt Request Line (IRQ) for two onboard serial ports.

The available options for Onboard Serial Port 1/2 are : [3F8/IRQ4] [2F8/IRQ3] [3E8/IRQ4] [2E8/IRQ3] [Auto] [Disabled].

7.4.8 UART2 Mode Select **[Normal]**

RxD, TxD Active **[Hi,Lo]**

IR Transmission Delay **[Enabled]**

UR2 Duplex Mode **[Full]**

Use IR Pins **[IR-Rx2Tx2]**

7. BIOS Configuration

The IrDA is Hewlett Packard infrared communication protocol with maximum baud rate up to 115.2K bps, and the ASKIR is Sharp infrared communication protocol with maximum baud rate up to 57.6K bps. The UART2 Mode Setting depends on which type of infrared module is used in the system. When set to "ASKIR" or "IrDA", the UART2 is used to support the infrared module connected on the motherboard. If this option is not set to "Normal", a device connected to the COM2 port will no longer work.

RxD, TxD Active. It will define voltage level to match for your infrared module used in the system.

IR Transmittion Delay. When set to "Enabled", you will utilize, the capability of your motherboard to allow for faster infrared transmittion rates.

The available options for UART2 Mode Select are : [Normal] [IrDA] [ASKIR].

The available options for RxD, TxD Active are : [Hi,Lo] [Lo,Hi] [Lo,Lo] [Hi, Hi].

The available options for IR Transmittion Delay are : [Enabled] [Disabled].

The available options for UR2 Duplex Mode are : [Full] [Half].

The available options for Use IR Pins are : [IR-Rx2Tx2] [RxD2, TxD2].

7.4.9 Onboard Parallel Port [378/IRQ7]

This item controls the onboard parallel port address and Interrupt.

The available options for Onboard Parallel Port are : [378/IRQ7] [278/IRQ5] [3BC/IRQ7] [Disabled].

7.4.10 Parallel Port Mode [SPP]

EPP Mode Select [EPP1.7]

ECP Mode Use DMA [3]

These item lets you set the parallel port mode.

- **[SPP]** : Standard Parallel Port is the IBM AT and PS/2 compatible mode.
- **[EPP]** : Enhanced Parallel Port is enhances the parallel port throughput by directly writing/reading data to/from parallel port without latch.
- **[ECP]** : Extended Parallel Port is supports DMA and RLE (Run Length Encoded) compression and decompression.

EPP Mode Select item lets you select EPP version to match your parallel device.

ECP Mode Use DMA item lets you set the DMA channel of ECP mode.

The available options for Parallel Port Mode are : [SPP] [EPP] [ECP] [ECP+EPP].

The available options for EPP Mode Select are : [EPP1.7] [EPP1.9].

The available options for ECP Mode Use DMA are : [3] [1].

7.4.11 PWRON After PWR-Fail **[Off]**

A traditional ATX system should remain at power off stage when AC power resumes from power failure. This design is inconvenient for a network server or workstation, without an UPS, that need to keep power on. This item is used to solve this problem.

- **[Off]** : If you select Off, the system keep power-off state after AC power resumes.
- **[On]** : If you select On, the system can automatically power-on after AC power resume.
- **[Former-Sts]** : If you select Former-Sts, the system will power-on or power-off based on the original state.

The available options for PWRON After PWR-Fail are : [Off] [On] [Former-Sts].

7.4.12 Game Port Address **[201]**

This item let you disable the built-in Game port or enabled it by assigning an I/O address.

The available options for Game Port Address are : [201] [209] [Disabled].

7.4.13 Midi Port Address **[330]**

Midi Port IRQ [10]

This item let you disable the built-in Midi port or enabled it by assigning an I/O address and IRQ.

The available options for Midi Port Address are : [330] [300] [290] [Disabled].

The available options for Midi Port IRQ are : [10] [5].

After you have made your selection(s) in the Integrated Peripherals, press the <Esc> key to back to the main program screen.

7. BIOS Configuration

7.5 Power Management Setup

Selecting “Power Management Setup” on the main program screen display this menu :



The Power Management Setup option controls the power management functions. This motherboard supports ACPI (Advanced Configuration and Power management Interface). The system has various power saving modes that allows the system to be automatically resumed by certain events. To access the Power Management Setup screen, highlight this option on the main menu screen and press <Enter> key.

7.5.1 ACPI Function [Enabled]

This item allows you to Enabled or Disabled the ACPI (Advanced Configuration and Power management Interface) function.

The available options for ACPI Function are : [Enabled] [Disabled].

7.5.2 ACPI Suspend Type [S1 (POS)]

This item allows you to set how your system suspends.

- **[S1(POS)]** : This suspend mode is equivalent to a software power down.
- **[S3(STR)]** : This motherboard features the suspend to RAM function. In a suspend to RAM, the system is totally powered down with the exception of the small current required to refresh the system memory. To resume from a suspend to RAM, press the power button (or use the hot keys or password if you have enabled a hot key or password power on). The system will resume in just a few seconds,

and it will appear in exactly the same state as it was before it was suspended to RAM.

The available options for ACPI Suspend Type are : [S1(POS)] [S3(STR)].

7.5.3 Power Management [User Define]

Suspend Mode [Disabled]

HDD Power Down [Disabled]

These items acts like a master switch for the power saving mode and hard disk timeout.

- **[User Define]** : Set to User Define to choose your own timeout for the power saving modes.
- **[Min Saving]** : Set to Min Saving, power saving modes occur after a longer timeout.
- **[Max Saving]** : Set to Max Saving, power saving modes occur after a short timeout.

Suspend Mode item lets you set the period of time after which the system enters into suspend mode. The suspend mode can be power on suspend or suspend to hard drive. HDD Power Down item lets you set the IDE HDD idle time before the device enters the power down state.

The available options for Power Management are : [User Define] [Min Saving] [Max Saving].

The available options for Suspend Mode are : [Disabled] [Enabled].

The available options for HDD Power Down are : [Disabled] [Enabled].

7.5.4 Video Off Method [V/H SYNC+Blank]

This item set the video off method in power saving mode.

- **[V/H SYNC + Blank]** : BIOS will blanks the screen and turn off vertical and horizontal scanning when gets into power saving mode.
- **[DPMS]** : This function applies only for DPMS (Display Power Management Standard) monitor. BIOS will use DPMS to control VGA display controller.
- **[Blank Screen]** : Only blanks the screen when gets into power saving mode.

The available options for Video Off Method are : [V/H SYNC+Blank] [DPMS] [Blank Screen] .

7.5.5 Video Off In Suspend [Yes]

It is define if the Video is powered down when the system is put into suspend mode.

The available options for Video Off In Suspend are : [Yes] [No].

7. BIOS Configuration

7.5.6 Suspend Type **[Stop Grant]**

You can set suspend mode by this item.

- **[Stop Grant]** : If Stop Grant is selected, the CPU clock will enter into sleep mode.
- **[PwrOn Suspend]** : If PwrOn Suspend is selected, the CPU will enter into doze mode.

The available options for Suspend Type are : [Stop Grant] [PwrOn Suspend].

7.5.7 MODEM Use IRQ **[3]**

If you want an incoming call on a modem to automatically resume the system from a power saving mode, use this option to specify the IRQ that is used by the modem. You might have to connect the fax/modem to onboard modem connector for this feature to work.

The available options for MODEM Use IRQ are : [3] [4] [5] [7] [9] [10] [11] [NA].

7.5.8 Soft-Off by PWR-BTTN **[Instant-Off]**

Under ACPI (Advanced Configuration and Power management Interface) you can create a software power down. This item lets you install a software power down that is controlled by the normal power button on your system.

- **[Instant-Off]** : When Instant-Off is selected, the power button causes a software power down.
- **[Delay 4 sec.]** : When Delay 4 sec. is selected, the power button can be used to control power on, Suspend and Off, If the power button is pressed less than 4 sec during power on, the system will go into suspend mode. If the power button is pressed longer than 4 sec, the system will be turned off.

The available options for Soft-Off by PWR-BTTN are : [Instant-Off] [Delay 4 Sce.].

7.5.9 Wake-Up by PCI card **[Disabled]**

If you enable this item that allows activity on an add-on card (must be meet PCI v2.2 specification) in one of the PCI slots to resume the system from a power saving mode.

The available options for Wake-Up by PCI card are : [Disabled] [Enabled].

7.5.10 Power On By Ring/LAN **[Disabled]**

If "Enabled", the system power will be turned on if the FAX/Modem receives an incoming telephone call. You might have to connect the fax/modem to the motherboard modem connector for this feature to work.

The available options for Power On By Ring/LAN are : [Disabled] [Enabled].

7.5.11 CUP Thermal-Throttling [50.0%]

This option defines what percentage of time the system will halt the processor clock when it is in power-saving mode.

The available options for CPU Thermal-Throttling are : [50.0%] [37.5%] [25.0%] [12.5%] [87.5%] [75.0%] [62.5%].

7.5.12 Resume By Alarm [Disabled]

Date (of Month) Alarm [0]

Time (hh : mm : ss) Alarm [0 0 0]

If "Enabled", it allows you to set a date and time alarm that will automatically resume the system from a software power down. When you enable this feature, new setup items appear to let you set the alarm. Date (of Month) Alarm lets you select a day from 1 to 31. Time Alarm lets you select a time for the alarm in hours, minutes, and seconds.

The available options for Resume By Alarm are : [Disabled] [Enabled].

The available options for Date (of Month) Alarm are : [0~31].

The available options for Time (hh:mm:ss) Alarm are : [0~23:0~59:0~59].

7.5.13 Reload Global Timer Events

Primary IDE 0/1 [Enabled]

Secondary IDE 0/1 [Enabled]

FDD, COM, LPT, Port [Enabled]

PCI PIRQ [A-D] # [Enabled]

When these items is enabled, the system will restart the power saving timeouts counter when any activity is detected on the system's IDE HDD, FDD. Serial and Parallel devices and IRQ signal.

The available options are : [Enabled] [Disabled].

After you have made your selection(s) in the "Power Management Setup", press the <Esc> key to back to the main program menu.

7. BIOS Configuration

7.6 PnP/PCI Configurations

Selecting “PnP/PCI Configurations” on the main program screen display this menu :

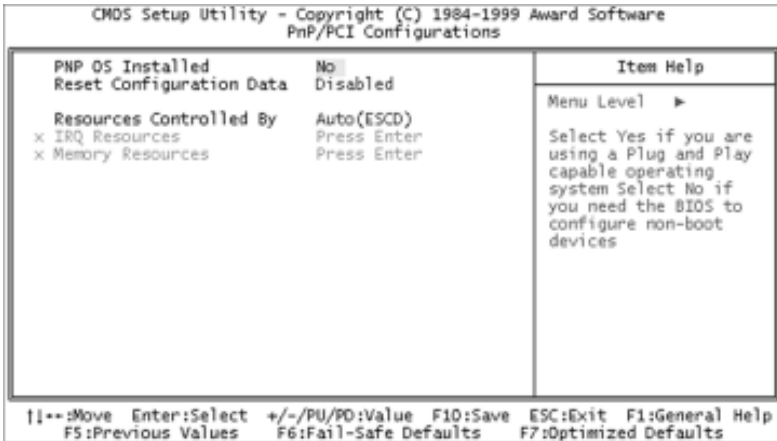

This option that configures how PnP and PCI expansion slots operate on the motherboard use system IRQs & DMAs. You must setup the IRQ and DMA assignment correctly through the PnP/PCI Configuration setup Utility, otherwise the motherboard will not work properly.

7.6.1 PnP OS Installed [No]

If you have installed a PnP operation system such as Windows 95 or 98, you can set this item to Yes. The Device Manager Utility in the operation system to make changes to the configuration of expansion cards.

The available options for PnP OS Installed are : [No] [Yes].

7.6.2 Reset Configuration Data [Disabled]

If you enabled this item and restart the system, any PnP configuration data stored in the BIOS setup is cleared from memory. New updated data is created.

The available options for Reset Configuration Data are : [Disabled] [Enabled].

7.6.3 Resources Controlled By [Auto (ESCD)]

IRQ Resources [Press Enter]

Memory Resources [Press Enter]

You should leave this item at the default [Auto (ESCD)]. Under this setting, the system dynamically allocates resources to PnP devices as they are required.

The available options for Resources Controlled By are : [Auto (ESCD)] [Manual].

The available options for IRQ/Memory Resources are : [Press Enter].

After you have made you selection(s) in the PnP/PCI Configuration setup, press the <Esc> key to go back to the main program screen.

7.7 PC Health Status

Selection “PC Health Status” on the main program screen display this menu :

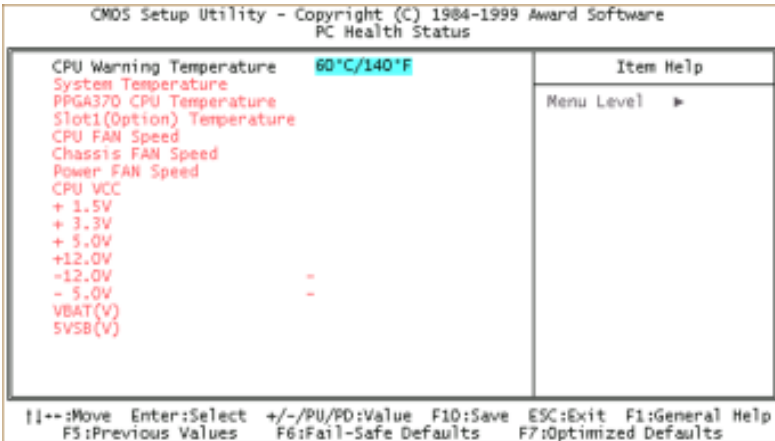

This option allows you to set CPU Warning Temperature on the motherboard, also display will list a series of items such as critical voltage and fan speeds.

7.7.1 CPU Warning Temperature [60°C/140°F]

This item is used to set a CPU warning temperature. When the CPU's temperature is higher than this presage fined value, the CPU's speed will automatically slow down and there will be a warning from BIOS and system buzzer will beep. The beep sound will not off unless you turn off system and change CPU's cooling condition. This feature gives CUP overheat protection.

The available options for CPU Warning Temperature are : [60°C/140°F] [63°C/145°F] [66°C/151°F] [70°C/158°F] [Disabled] [50°C/122°F] [53°C/127°F] [56°C/133°F].

After you have made your selection in the PC Health Status, press the <Esc> key to back to the main program screen.

7. BIOS Configuration

7.8 Frequency Control

Selecting “**Frequency Control**” on the main program screen display this menu :

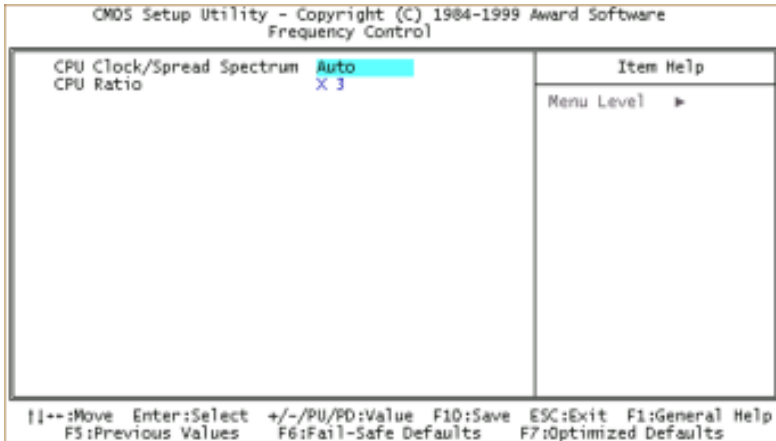

The CPU Bus Clock and System Clock frequency will automatically be modulated which helps reducing electromagnetic interference.

7.8.1 CPU Clock/Spread Spectrum [Auto]

This option sets the CPU Bus Clock/Spread Spectrum to Auto, system clock frequency will automatically be modulated which helps reducing electromagnetic interference. When you install FSB 66MHz or 100MHz processor that will be auto detecte CPU Bus Clock. We recommend that you leave this option at the default value.

The available options for CPU Clock/Spread Spectrum are : [Auto] [66MHz/Off] [66MHz/On] [75MHz/Off] [83MHz/Off]. For FSB 66MHz processors use.

The available options for CPU Clock/Spread Spectrum are : [Auto] [95MHz/Off] [100MHz/On] [100MHz/Off] [112MHz/On] [117MHz/On] [124MHz/Off] [133MHz/Off] [133MHz/On] [138MHz/Off] [140MHz/On] [150MHz/Off]. For FSB 100MHz processors use.

7.8.2 CPU Ratio [X3]

This option allows you set CPU Core to Bus Clock Multiplier for your processor.

3 (CPU ratio) X 100MHz (CUP clock) = 300MHz (CPU speed)

The available options for CPU Ratio are : [X3] [X3.5] [X4] [X4.5] [X5] [X5.5] [X6] [X6.5] [X7] [X7.5] [X8].

After you have made your selection in the Frequency Control, press the <Esc> key to go back to the main program screen.

7.9 Load Fail-Safe Defaults

Selecting “**Load Fail-Safe Defaults**” on the main program screen and press <Enter> key on this option. You get a confirmation dialog box with a message display this menu :

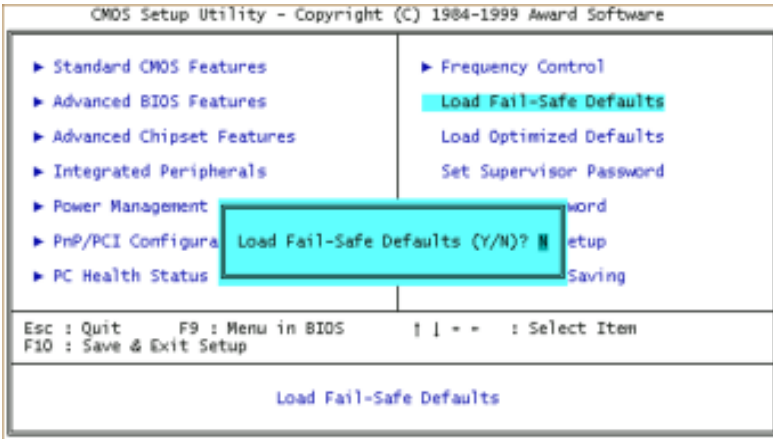

When you pressing “Y” key to load the BIOS default values for the most stable, minimal performance system operations.

7.10 Load Optimized Defaults

Selecting “**Load Optimized Defaults**” on the main program screen and press <Enter> key on this option. You get a confirmation dialog box with a message display this menu :

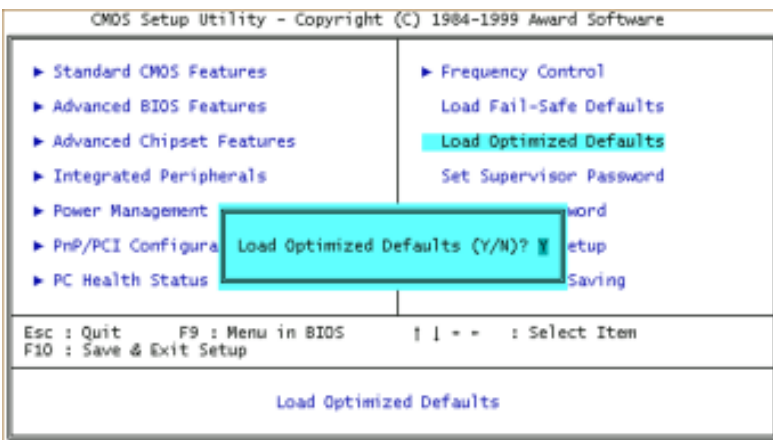

When you pressing “Y” key to load the default values that are factory setting for optimal performance system operations.

7. BIOS Configuration

7.11 Set Supervisor / User Password

You can set either Supervisor or User Password, or both of them. The differences between are :

- Supervisor Password : Can enter and change the options of the setup menus.
- User Password : Just can only enter but do not have the right to change the options of the setup menus.

When you select these function, the following message will appear at the center of the screen to assist you in creating a password.

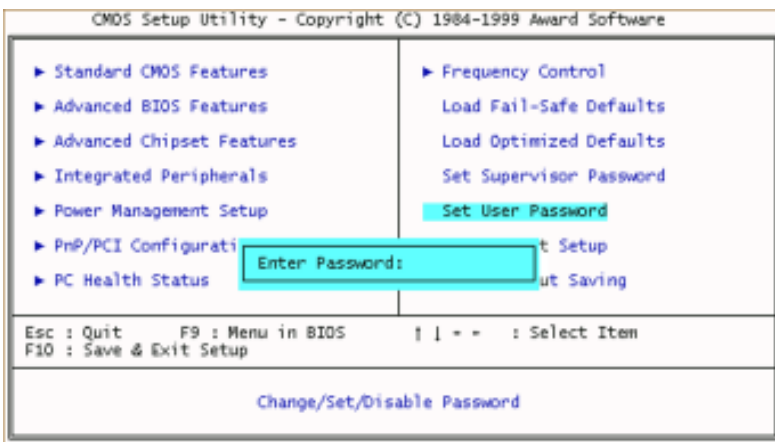
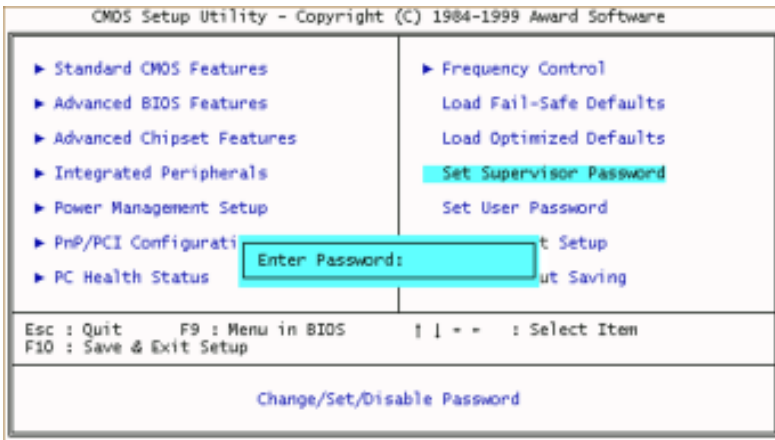

Type the password, up to eight characters in length, and press <Enter> key. The password typed now will clear any previously entered password from CMOS memory. It will be asked to confirm the password, Type the password again and press <Enter> key, or you may also press <Esc> key to abort the selection and not enter a password.

To disabled a password, just press <Enter> key when you are prompted to enter the password. A message will confirm the password will be disabled. Once the password is disabled, the system will boot and you can enter setup freely.

When a password has been enabled, you will be prompted to enter it every time you try to enter setup. This prevents an unauthorized person from changing any part of your system configuration.

Additionally, when a password is enabled, you can also require the BIOS to request a password every time your system is rebooted. This would prevent unanthonzed use of your system. You determine when the password is required within the Advanced BIOS Feature setup menu and its Security Options. If the security option is set to "System" the password will be required both at boot and at enter to setup. If set to "Setup", prompting only occurs when trying to enter setup.

7. BIOS Configuration

7.12 Save & Exit Setup/Exit Without Saving

Selecting **“Save & Exit Setup”** on the main program screen and press <Enter> key on this option. You get a confirmation dialog box with a message display this menu :

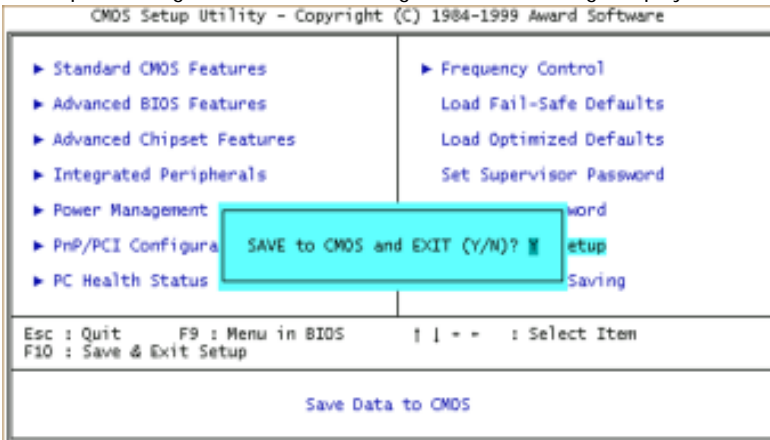

Pressing <Y> key to stores the selections made in the menus in CMOS special section of memory that stays on after you turn your system off. The next time you boot your system, the BIOS configures your system according to the setup selections stored in CMOS. After saving the values the system is restarted again.

Selecting **“Exit Without Saving”** on the main program screen and press <Enter> key on this option. You get a confirmation dialog box with a message display this menu :

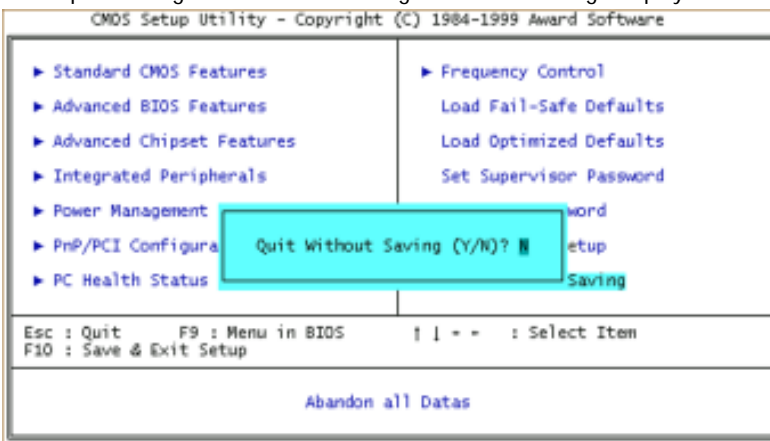

This allow you to exit setup without storing in CMOS any change. The previous selections remain in effect. This exits the setup Utility and restarts your system.

8. Software Installation

This installation guide is designed to install Driver and Utility software in Windows OS. We recommend that you read this section thoroughly before starting your installation. Although i810 series motherboard passed testing on several operating system, some folders are subdivided into different operating systems such as DOS, Windows 95/98/NT and so on. Always make sure that you are installing the correct software for the operating system on your system.

8.1 Installation

- Insert the Driver and Utility CD into your CD-ROM drive to begin the software installation. If you are running Windows OS with Autorun enabled, the opening screen of the CD appears automatically or double click the "CD drive" icon in "My Computer" to bring up the install screen Figure 1, then click "810 Serial Product" under "Pentium II/III Series Motherboard" the following right screen will appear Figure 2.



Figure 1



Figure 2

- Click "M81DC-X" or others X Series Mode (mode of your motherboard) under "Socket 370 Intel 810 Series Motherboard" the following screen will appear Figure 3.



Figure 3

8. Software Installation

8.2 DELTA Hardware Doctor 3.5 Installation

The system environment monitoring Utility with the onboard Winbond W83627HF-AW system monitor chip allow you to monitor your system's temperature, fan speed, CPU and system voltage. Using this Utility, you can setup the upper and lower limits of these monitored parameters. A per-warning message will pop up on the screen when the monitored parameters is out of the preset range. This software have to installed under Windows OS.

- Click "DELTA Hardware Doctor 3.5" on the Figure 3, the following screen will appear Figure 4.
- Click **OK**, the following screen will appear Figure 5 to install DELTA HARDWARE DOCTOR 3.5 program. The default directory is "C:\Program Files\HWDdoctor\".

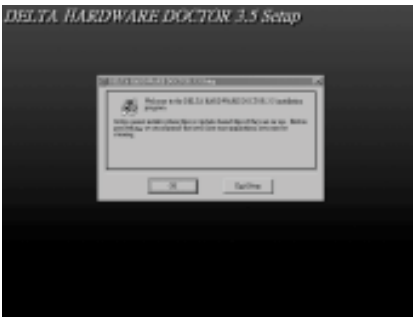

Figure 4



Figure 5

Follow the instructions on the screen to complete the installation. After install is completed, you need to restart the system before you can activate the program.

- The "DELTA HARDWARE DOCTOR 3.5" option will be added to the "Programs" directory. Click on the "DELTA HARDWARE DOCTOR 3.5" icon to access the program, the following screen will appear Figure 6.
- Click "DELTA HD35" icon, the following screen will appear Figure 7.

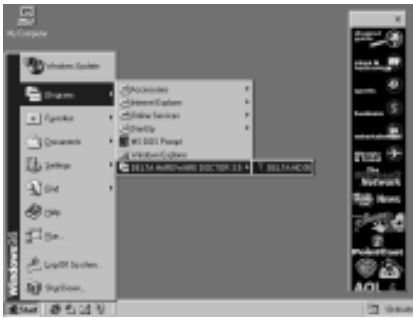

Figure 6

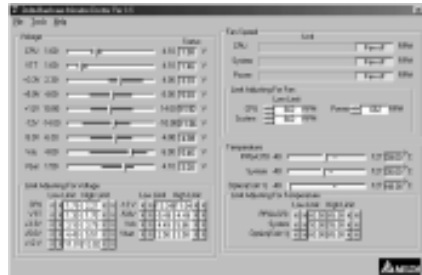

Figure 7

Set threshold you want for system temperature, voltage and fan speed, by moving the slide bars or by clicking the increase/decrease buttons.

8.3 Intel 810 VGA For Win98 Installation

- Click "Intel 810 VGA Install" on the Figure 3" the following screen will appear Figure 8.
- Click "Intel 810 VGA For Win98" on the Figure 8" the following screen will appear Figure 9. To continue install procedure then click **Next** ; ÷click **Yes** the following screen will appear Figure 10 to install Graphic Driver Software program. The default directory is **C:\Program Files\Intel\GfxDrvEUD**. Follow the instruction on the screen to complete the installation.



Figure 8

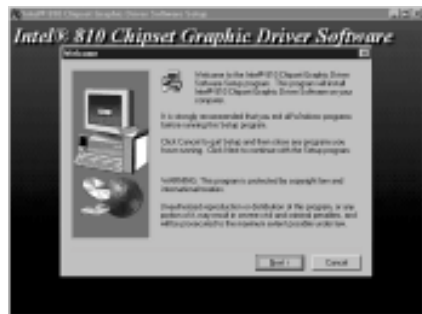

Figure 9

8. Software Installation



Figure 10

After install is completed, you need to restart the system before you can activate the program.

Reconfiguration under Windows 98 (Reconfiguring through the Device Manager).

- Click "Start" ; ÷select "Settings" ; ÷then click "Control Panel" the following screen will appear Figure 11.
- Double click on the "System" icon then select and click "Device Manager" ; ÷Hit the "+" symbol to the left of the "Display adapters" section, the following screen will appear Figure 12.



Figure 11

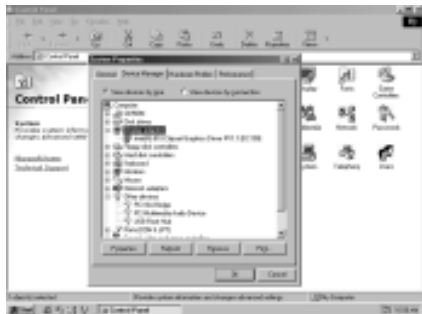

Figure 12

- Highlight the "Intel(R) 810 Chipset Graphics Driver PV 1.1 [DC100]" to explain the software install was completed successfully.

8.4 Intel 810 INF Installation

This Utility installs INF files in Windows OS for the following items : System and Graphics, Firmware Hub, PCI Bridge, Bus Master IDE, USB Host Controller.

- Click "Intel 810 INF install "on the Figure 3, the following screen will appear Figure 13.



Figure 13

Step 1 : Copy INF File to HD

- Click “Copy INF File to HD” the following screen will appear Figure 14. To continue install procedure and click **Next** ; ÷Click **Yes** the following screen will appear Figure 15 to install INF Files software program that default directory is C:\Program Files\Inte\Inte\INF.



Figure 14

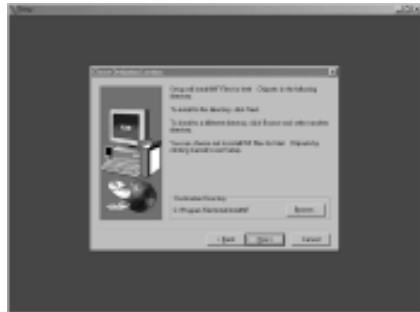

Figure 15

- Follow the instruction on the screen to complete the installation. After install is completed to go back to Figure 13.

Step 2 : Install INF Utility

- Click “Install INF Utility” the following screen will appear Figure 16 to continue install procedure and click **Next** ; ÷Click **Yes** ; ÷Click **Yes** ; ÷click **Next** the following screen will appear Figure 17. Then click **Next** to install Readme. txt software program that default directory is C:\Program Files\Inte\Inf\fnsh.

8. Software Installation



Figure 16

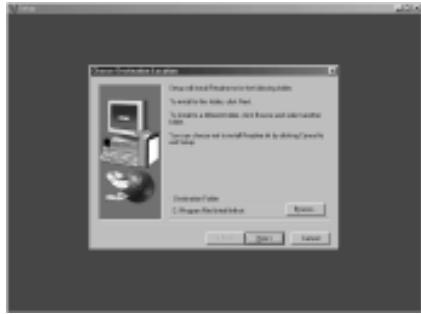

Figure 17

After install is completed, you need to restart the system before you can activate the program.

Reconfiguration under Windows 98 (Reconfiguring through the Device Manager).

- Click "Start" ; ÷select "Settings" ; ÷then select "Control Panel", the following screen will appear Figure 11.
- Double click on the "System" icon then click "Device Manager" ; ÷Hit the "+" symbol to the left of the "Other Devices" section, the following screen will appear Figure 18.

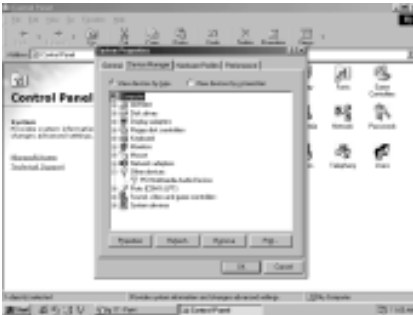

Figure 18

- Highlight the Intel 810 INF software install was completed successfully.

8.5 Audio Driver Readme Installation

Please allow the path to the `:\Intel810\810AUDIO\Win98` when your system detects the installed audio system. To install the audio applications, log on to the Win98 folder and the log on to the Ap folder. Run the setup program.

8.6 BIOS Utility Installation

The BIOS of the i810 series motherboard can be upgraded by using a BIOS Utility. A new

version of the BIOS can be downloaded from the Web site : <http://pc.delta.com.tw>. The system BIOS is stored in a 4MB Firmware Hub chip which can be erased and reprogrammed by the BIOS Utility. There are two files in the BIOSTOOL directory.

- **AWDFLASH.EXE** The Flash Utility for AWARD BIOS upgrade.
- **SETUP** The setup directory for uninstall program.

To use the Utility, you must be in real-mode DOS (not the DOS icon that is available in windows OS). If you are using Windows 95/98, shut down your system and select the option restart in DOS in the shutdown dialog box in order to run the flash memory Utility. You can easily Flash a BIOS by following the steps below :

- After downloading the appropriate BIOS file from Web site, extract it to a bootable MS-DOS 6.XX diskette.
- If you are using MS-DOS 6.XX, reboot your system with the bootable diskette in the A : drive. To make sure a real-mode DOS environment is loaded, press the <F5> key while "Starting MS-DOS" is displayed. After the system has rebooted, the cursor will appear at the A:\>prompt.
- Now you can run the Flash Utility from the A:\> prompt. For example, to update the M81DC-X to BIOS version XX, you would type:
A:\>AWDFLASH P8X200.BIN then press <Enter> key.
- After the flash screen appear, select [Yes] to save the current BIOS or [No] if you do not want to save the current BIOS. We recommended that you save the current BIOS.
- When prompted, select [Yes] to reprogram the BIOS.
- After the update process has completed, you will be prompted to power off or reset your system. Once the system reboots, verify that the new BIOS version appear on the screen.

Note : After reprogramming the BIOS, you may need to enter BIOS setup and reset your settings.

DECLARATION OF CONFORMITY



This device is in conformance with Part 15 of the FCC Rules and Regulations for Information Technology Equipment. Operation of this Product is subject to the following two conditions : (1) this device may not cause harmful interference, and (2) this device must accept any interference received, including interference that may cause undesired operation.

Responsible Party Name : DELTA PRODUCTS CORPORATION
Address : 4405 CUSHING PARKWAY FREMONT.CA
94538, U.S.A.
Contact Person / Title : Executive Vice President / Frank Hsiung
Telephone : 1-510-668-5100
Fax : 1-510-668-0680

EUT Certification Summary

Srandard : FCC Part 15, Subpart B, Class B ANSI C63.4-1992
Product : MOTHER BOARD
Model No. : M81DC-X / M81L-X / M81-X
Tested by : SPORTON INTERNATIONAL INC.

The Mother Board was tested to conform to the applicable FCC Rule and regulations. The method of testing was in accordance to the most accurate measurement standards possible, equipment will continue to comply with the Federal Communications Commission's requirements.

Representative Person's Name : Frank Hsiung

Signature : 

Date : Jul. 5, 1999

EC DECLARATION OF CONFORMITY

This certifies that the following designated product

MOTHER BOARD

MODEL NO. : M81DC-X / M81L-X / M81-X

(Product identification)

complies with the essential protection requirements of Council Directive 89/336/ECC on the approximation of the laws of the Member States relating to electromagnetic compatibility. This declaration applies to all specimens manufactured in accordance with the attached manufacturing drawings which form part of this declaration.

Assessment of compliance of the product with the requirements relating to electromagnetic compatibility was based on the following standards :

EN 50081-1 / 1992 : EN55022

EN 50082-1 / 1997 : EN61000-4-2/-3/-8, EN 50204

(Identification of regulations / standards)

This declaration is the responsibility of the manufacturer / importer

DELTA ELECTRONICS, INC.

11F-3, 266, 2ND WEN-HWA ROAD., SEC. 1, LINKOU,

TAIPEI HSIEN, TAIWAN, R.O.C.

(Name / Address)



(EC conformity marking)

MANUFACTURER / IMPORTER

August 16, 1999

.....
(Date)

Alex Cho

.....
Alex Cho