

Mainboard User's Manual

This publication, including all photographs, illustrations and software, is protected under international copyright laws, with all rights reserved. Neither this manual, nor any of the material contained herein, may be reproduced without the express written consent of the manufacturer.

The information in this document is subject to change without notice. The manufacturer makes no representations or warranties with respect to the contents hereof and specifically disclaims any implied warranties of merchantability or fitness for any particular purpose. Further, the manufacturer reserves the right to revise this publication and to make changes from time to time in the content hereof without obligation of the manufacturer to notify any person of such revision or changes.

Trademarks

IBM, VGA, and PS/2 are registered trademarks of International Business Machines.

Intel, Pentium, Pentium-II, Pentium-III, MMX, and Celeron are registered trademarks of Intel Corporation.

Microsoft, MS-DOS and Windows 95/98/NT/2000 are registered trademarks of Microsoft Corporation.

Sound Blaster is a trademark of Creative Technology Ltd.

PC-cillin and ChipAwayVirus are trademarks of Trend Micro Inc.

AMI is a trademark of American Megatrends Inc.

A3D is a registered trademark of Aureal Inc.

Gamut is a registered trademark of Formosoft International Inc.

SuperVoice is a registered trademark of Pacific Image Communications Inc.

MediaRing Talk is a registered trademark of MediaRing Inc.

3Deep is a registered trademark of E-Color Inc.

Other names used in this publication may be trademarks and are acknowledged.

**Copyright © 2001
All Rights Reserved
M756T+ Series, V5.2
S63X/January 2001**

Mainboard User's Manual

Notice:

1. Please insert the Slot-1 card shipped with this product to the SLOT1 as below, if you installed a Socket-370 processor on the mainboard.

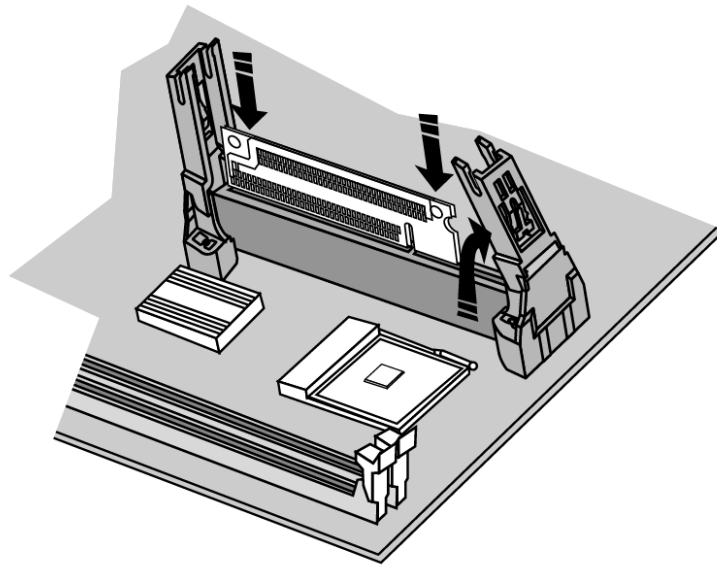

2. Please **avoid** to do “**Clear CMOS**” and “**reFlash BIOS**” operations simultaneously.
3. If the user needs to do the above operations simultaneously, the user must to reprogram the LAN ID, and its procedure is as follows:
 - a. You may find the LAN ID on the motherboard at least.
 - b. You may find the programming utility (EE.ZIP) on our Web site – <http://www.pcchips.com.tw/bios.html> or on the Driver CD disc (\LAN\SiS900\Utility\).
 - c. Please follow the “README.TXT” (After unzipping EE.ZIP or under the directory \LAN\SiS900\Utility\ instruction to reprogram your LAN ID.

Mainboard User's Manual

Table of Contents

Chapter 1: Introduction.....	1
Key Features.....	2
Package Contents.....	5
Static Electricity Precautions.....	6
Pre-Installation Inspection.....	6
Chapter 2: Mainboard Installation.....	7
Mainboard Components.....	8
I/O Ports.....	8
Install A CPU.....	9
Install Memory.....	12
Setting Jumper Switches.....	13
Install the Mainboard.....	15
Install the Extension Brackets.....	16
Optional Extension Brackets.....	17
Install Other Devices.....	18
Expansion Slots.....	20
Chapter 3: BIOS Setup Utility.....	21
Introduction.....	21
Running the Setup Utility.....	22
Standard CMOS Setup Page.....	23
Advanced Setup Page.....	24
Power Management Setup Page.....	26
PCI / Plug and Play Setup Page.....	28
Load Optimal Settings.....	29
Load Best Performance Settings.....	29
Features Setup Page.....	30
CPU PnP Setup Page.....	32
Hardware Monitor Page.....	33
Change Password.....	34
Exit.....	34
Chapter 4: Software & Applications.....	35
Introduction.....	35
Installing Support Software.....	35
Installing Under Windows 98.....	37

Mainboard User's Manual

Appendix A: Corel WordPerfect Suite 8	A1
Welcome to Corel WordPerfect Suite 8	A2
Installing Corel WordPerfect Suite 8	A6
Learning how to use Corel WordPerfect Suite 8	A9
Support and Services	A13
Appendix B: Gamut2000	B1
1. GAMUT2000 Family	B2
1.1 LifeAmp - Versatile Audio Playback System	B2
1.2 AudioPort - Audio Transportation System	B4
2. Installation	B5
2.1 Before Beginning: System Requirements	B5
2.2 Uninstalling the Previous of GAMUT2000.....	B5
3. Main Console	B7
3.1 Introduction	B7
3.2 Function and Operation	B7
3.3 Main Menu	B9

Chapter 1

Introduction

This mainboard has a **Slot 1** processor socket for an **Intel SEPP Celeron, Pentium II or III** CPUs. It also has a **Socket 370**, which uses an **Intel PPGA/ FCPGA Celeron or FCPGA Pentium-III** processor. You can install any one of these processors on the mainboard.

This mainboard supports front-side bus speeds of **66MHz, 100MHz or 133MHz**.

This mainboard uses the GFXcel chipset which provides **CPU Plug & Play** through firmware, integrates a **128-bit AGP Graphics Accelerator**. The mainboard has a built-in **AC97 Codec**, provides an **AMR** (Audio Modem Riser) slot to support Audio and Modem application, and has a built-in **10BaseT/ 100BaseTX Network Interface**. In addition, the mainboard has an extended set of **ATX I/O Ports** including PS/2 keyboard and mouse ports, two USB ports, a parallel port, a serial port and a VGA port.

This mainboard has all the features you need to develop a powerful multimedia workstation that is network ready, and has built-in communications. The board is **micro-ATX size** and has power connectors for an **ATX** power supply.

Caution:

- Cyrix III 133MHz FSB CPUs do not support, please refer to page 9.
- You cannot install two processors simultaneously on this mainboard.

Mainboard User's Manual

Key Features

The key features of this mainboard include:

Slot-1 Processor Support

- ◆ Pentium III, Pentium II and SEPP Celeron CPUs are supported
- ◆ Supports 66MHz, 100MHz or 133MHz Front-Side Bus

Socket-370 Processor Support

- ◆ Supports PPGA/FCPGA Celeron and FCPGA Pentium III CPUs
- ◆ Supports 66MHz, 100MHz or 133MHz FSB

All processors are automatically configured using firmware and a synchronous/asynchronous Host/DRAM Clock Scheme.

Memory Support

- ◆ Two DIMM slots for 168-pin SDRAM memory modules
- ◆ Support for 66MHz, 100MHz, & 133MHz memory bus
- ◆ Maximum installed memory is 2 x 512MB = 1 GB

Expansion Slots

- ◆ Two 32-bit PCI slots
- ◆ One AMR slot for a special audio/modem riser card

Onboard IDE channels

- ◆ Primary and Secondary PCI IDE channels
- ◆ Support for PIO (programmable input/output) modes
- ◆ Support for Multiword DMA modes
- ◆ Support for Bus Mastering and Ultra DMA 33/66 modes

Power Supply and Power Management

- ◆ ATX power supply connector
- ◆ ACPI and previous PMU support, suspend switch, keyboard power on/off
- ◆ Supports Wake on Modem, Wake on LAN and Wake on Alarm

1: Introduction

Built-in Graphics System

- ◆ Onboard 128-bit 2D/3D 100MHz Host interface **AGP Graphics Accelerator** Complies with AGP V2.0
- ◆ Shared memory architecture allows a maximum of 64 MB main memory to act as frame buffer
- ◆ Supports high resolutions up to 1920x1200 16M colors, up to 2048x2048 Texture size and Virtual screen up to 4096x4096
- ◆ Supports hardware DVD Accelerator

AC97 Codec

- ◆ Compliant PC97 2.1 specification
- ◆ Supports 18-bit ADC (Analog Digital Converter) and DAC (Digital Analog Converter) as well as 18-bit stereo full-duplex codec

Onboard I/O Ports

- ◆ Provides PC99 Color Connectors for easy peripheral device connections
- ◆ Floppy disk drive connector with 1Mb/s transfer rate
- ◆ One serial port with 16550-compatible fast UART
- ◆ One parallel port with ECP and EPP support
- ◆ Two USB ports and optional two USB ports module
- ◆ Two PS/2 ports for keyboard and mouse
- ◆ One infrared port header for optional module

Hardware Monitoring

- ◆ Built-in hardware monitoring for CPU & System temperatures, fan speeds and mainboard voltages

Built-in Ethernet LAN

- ◆ **10BaseT/100BaseTX Ethernet LAN**
- ◆ LAN controller integrates Fast Ethernet MAC and PHY compliant with IEEE802.3u 100BASE-TX, 10BASE-T and ANSI X3.263 TP-PMD standards
- ◆ Compliant with ACPI 1.0 and the Network Device Class Power Management 1.0

Mainboard User's Manual

- ◆ High Performance provided by 100Mbps clock generator and data recovery circuit for 100Mbps receiver

Onboard Flash ROM

- ◆ Automatic CPU and board configuration
- ◆ Supports Plug and Play configuration of peripheral devices and expansion cards
- ◆ Built-in virus protection using **Trend's ChipAwayVirus** provides boot process virus protection.

Bundled Software

- ◆ **PC-Cillin2000** provides automatic virus protection under Windows 95/98/2000/NT
- ◆ **SuperVoice** is data, fax and voice communication software
- ◆ **Gamut2000** provides professional audio features included MP3 encoding/playback
- ◆ **MediaRing Talk** provides PC to PC or PC to Phone internet phone communication
- ◆ **3Deep** delivers the precise imagery and displays accurate color in your monitor
- ◆ **Corel WordPerfect Suite 8** is a Windows® base office application suite (optional)
- ◆ **WinDVD2000** is a DVD playback application (optional)

Dimensions

- ◆ Micro-ATX form factor (24.4cm x 19cm)

1: Introduction

Package Contents

Attention: This mainboard series includes four different models. They are M756LMRT+ (LAN/Modem Ready), M756LRT+ (LAN Ready), M756MRT+ (Modem Ready) and M756T+ (without LAN & Modem).

Please contact your local supplier for your purchase model.

Each model will support different specification, list as below:

Model	Specification
M756LMRT+	Onboard LAN header (LAN1), LAN extension bracket and an AMR v.90 56K Fax/Modem card
M756LRT+	Onboard LAN header (LAN1) and LAN extension bracket
M756MRT+	Support an AMR v.90 56K Fax/Modem card
M756T+	---

Your mainboard package ships with the following items:

- The mainboard
- This User's Guide
- 1 UDMA/66 IDE cable
- Floppy disk drive cable
- Support software on CD-ROM disk

Optional Accessories

You can purchase the following optional accessories for this mainboard.

- Extended USB module

Mainboard User's Manual

Static Electricity Precautions

Components on this mainboard can be damaged by static electricity. Take the following precautions when unpacking the mainboard and installing it in a system.

1. Keep the mainboard and other components in their original static-proof packaging until you are ready to install them.
2. During installation, wear a grounded wrist strap if possible. If you don't have a wrist strap, discharge static electricity by touching the bare metal of the system chassis.
3. Handle the mainboard carefully by the edges. Avoid touching the components unless it is absolutely necessary. During installation put the mainboard on top of the static-protection packaging it came in with the component side facing up.

Pre-Installation Inspection

1. Inspect the mainboard for damage to the components and connectors on the board.
2. If you suspect that the mainboard has been damaged, do not connect power to the system. Contact your mainboard vendor and report the damage.

Chapter 2

Mainboard Installation

To install this mainboard in a system, follow the procedures in this chapter:

- ❑ Identify the mainboard components
- ❑ Install a CPU
- ❑ Install one or more system memory modules
- ❑ Verify that any jumpers or switches are set correctly
- ❑ Install the mainboard in a system chassis (case)
- ❑ Connect any extension brackets or cables to the mainboard connector headers
- ❑ Install any other devices and make the appropriate connections to the mainboard connector headers.

Note:

1. Before installing this mainboard, make sure jumper JP7 is set to Normal, the default setting is set to Clear CMOS. See this chapter for information on locating JP7 and the setting options.
2. When installing this mainboard, make sure jumper JP9 is set to correct setting for the installed CPU. See this chapter for information on locating JP9 and the setting options.
3. Never connect power to the system during installation. Doing so may damage the mainboard.

Mainboard User's Manual

Mainboard Components

Use the diagram below to identify the major components on the mainboard.

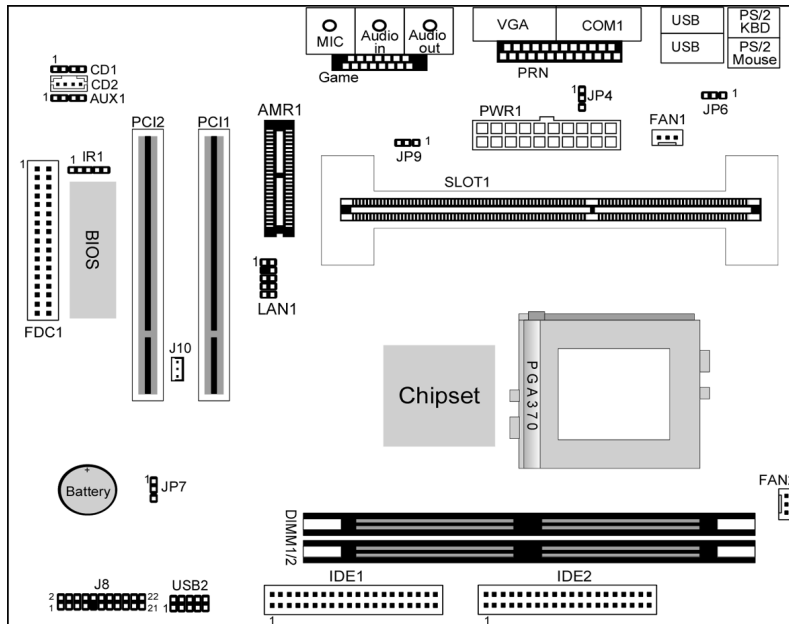

Note: Any jumpers on your mainboard that do not appear in this illustration are for testing only.

I/O Ports

The illustration below shows a side view of the built-in I/O ports on the mainboard.

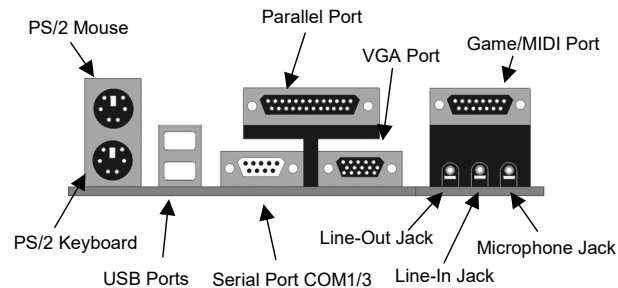

1: Introduction

Install A CPU

This mainboard has a Slot-1 CPU socket for any Slot-1 processor cartridge including the Pentium-III, Pentium-II and SEPP Celeron. It also has a Socket-370 which supports PPGA/FCPGA Celeron, FCPGA Pentium-III processor. You can install either a Slot 1 processor or a Socket. **You cannot install both a Socket-370 and a Slot-1 CPU.**

Do not try to install a Socket 7 processor in the Socket-370. A Socket 7 processor such as the Pentium-MMX, or the AMD K5/K6 does not fit in the Socket 370.

The following list notes the processors that are currently supported by this mainboard.

Pentium III: Slot-1, 450~866MHz, FSB: 100MHz/133MHz

Pentium II: Slot-1, 350~450MHz, FSB: 100MHz;
233~333Mhz, FSB: 66MHz

SEPP Celeron: Slot-1, 266~433MHz, FSB: 66MHz

PPGA/FCPGA Celeron: Socket-370, 300~766MHz, FSB: 66
MHz

FCPGA Pentium III: Socket-370, 500M~1.13GHz,
FSB: 100MHz/133MHz

Notice:

1. The default setting of this mainboard does NOT support Cyrix III CPUs.
2. If the user wants the M/B to work with Cyrix III CPU, two capacitors located as Figure-A and B must be taken out. However, the M/B may NOT support Intel's CPU any more after removing those two capacitors.

The capacitor on the back of Socket-370

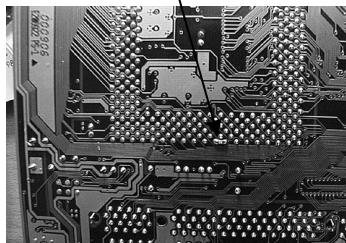

Figure-A

The capacitor C74

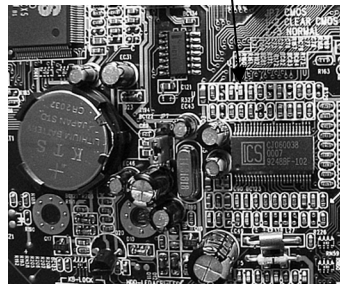
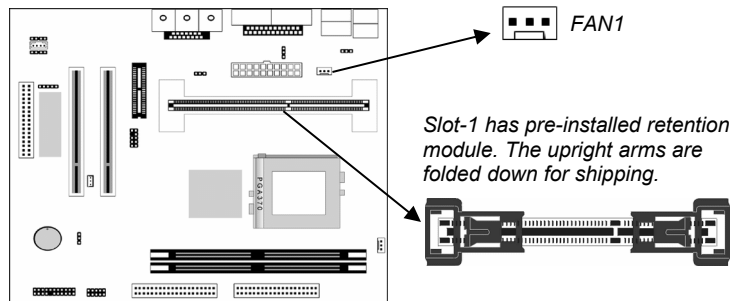

Figure-B

Mainboard User's Manual

Installing a Slot-1 Processor Cartridge CPU

1. Locate Slot-1 and FAN1 on the mainboard.



2. The Slot-1 is installed with a retention module. The upright arms of the module are folded down for shipping. Raise the arms so that they are in the upright position.

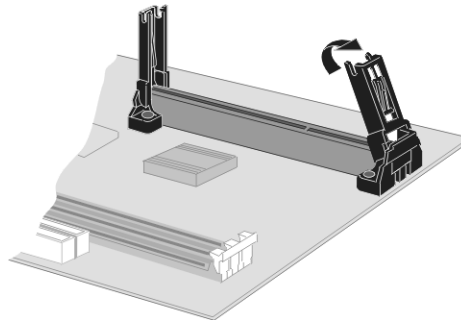

3. Slide the CPU cartridge into the module arms. Follow the instructions that come with the CPU. The edge connector on the CPU cartridge has a notch so that it only fits into the Slot-1 in the correct way.
4. Locate the cooling fan power supply FAN1. Connect the cable from the processor cartridge cooling fan to FAN1.
5. On this mainboard, you can configure the processor by entering the correct settings in the BIOS setup utility.

1: Introduction

Installing a Socket-370 Processor

A PPGA/FCPGA processor install into the ZIF (Zero Insertion Force) Socket-370 on the mainboard.

1. Locate the Socket-370 and FAN1. Pull the locking lever out slightly from the socket and raise it to the upright position.

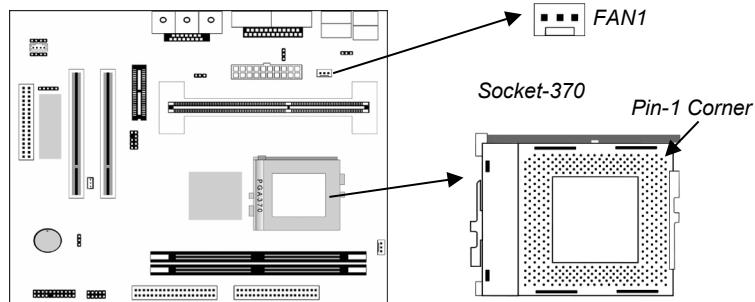

2. On the processor, identify the Pin-1 corner by its beveled edge.
3. On the Socket-370, identify the Pin-1 corner. The Pin-1 corner is at the end of the locking lever when it is locked.
4. Match the Pin-1 corners and insert the processor into the socket. No force is required and the processor should drop into place freely.
5. Swing the locking lever down and hook it under the catch on the side of the socket. This secures the CPU in the socket.
6. All PPGA/FCPGA processors should be installed with a combination heatsink/cooling fan, connect the cable from the fan to the CPU fan power connector FAN1.

Mainboard User's Manual

Install Memory

The mainboard has two DIMM sockets for system memory modules. You must install at least one memory module in order to use the mainboard.

You must install the first memory module in the DIMM1 socket to provide shared memory to the onboard VGA display circuitry.

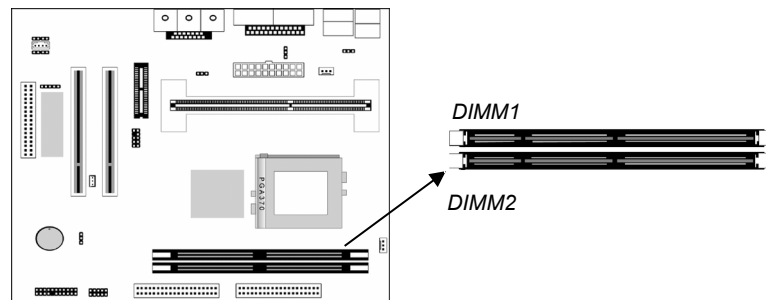

For this mainboard, you must use 168-pin, 3.3V unbuffered SDRAM memory modules. If the installed CPU uses a 100MHz system bus, you must use PC100 or PC133 memory. If the installed CPU uses a 66MHz system bus, you must use PC66 memory. You can install any size memory module from 16 MB to 512MB, so the maximum memory size is $2 \times 512\text{MB} = 1\text{GB}$.

The edge connectors on the memory modules have cut outs, which coincide with spacers in the DIMM sockets so that memory modules can only be installed in the correct orientation.

To install a module, push the retaining latches at either end of the socket outwards. Position the memory module correctly and insert it into the DIMM socket. Press the module down into the socket so that the retaining latches rotate up and secure the module in place by fitting into notches on the edge of the module.

Setting Jumper Switches

Jumpers are sets of pins which can be connected together with jumper caps. The jumper caps change the way the mainboard operates by changing the electronic circuits on the mainboard. If a jumper cap connects two pins, we say the pins are SHORT. If a jumper cap is removed from two pins, the pins are OPEN.

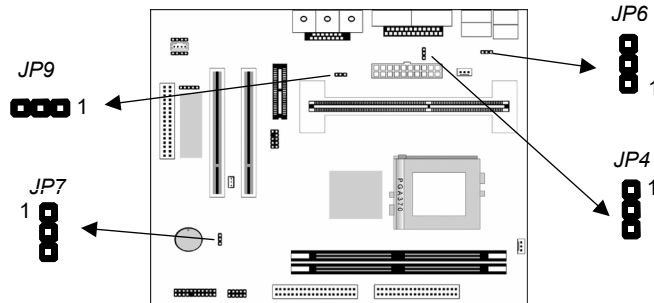

Jumper JP4: Onboard LAN Wakeup Selector

Use this 3-pin jumper to enable or disable the onboard LAN Wakeup function.

Function	Jumper Setting
Disable Wake On LAN	Short Pins 1-2
Enable Wake On LAN	Short Pins 2-3

Jumper JP6: Keyboard Power On Selector

If you enable the keyboard power on feature, you can use hot keys on your keyboard as a power on/off switch for the system.

Function	Jumper Setting
Disable Keyboard Power On	Short Pins 1-2
Enable Keyboard Power On	Short Pins 2-3

Note JP4 & JP6: The system must provide 1A on the +5VSB (+5V Standby) signal before using these two functions.

Mainboard User's Manual

Jumper JP7: Clear CMOS Memory

Use this jumper to clear the contents of the CMOS memory. You may need to clear the CMOS memory if the settings in the Setup Utility are incorrect and prevent your mainboard from operating. To clear the CMOS memory, disconnect all the power cables from the mainboard and then move the jumper cap into the CLEAR setting for a few seconds.

Function	Jumper Setting
Normal Operation	Short Pins 2-3
Clear CMOS Memory	Short Pins 1-2

Jumper JP9: FCPGA Pentium-III CPU Selector

Use this 3-pin jumper to select the installed CPU that is Socket-370 FCPGA CPUs or not. **Be careful, the error setting may damage the CPU.**

Function	Jumper Setting
Slot-1/PPGA CPUs	Short Pins 1-2
Socket-370 FCPGA CPUs	Short Pins 2-3

1: Introduction

Install the Mainboard

Install the mainboard in a system chassis (case). The board is a micro-ATX size mainboard with a twin-tier of I/O ports. You can install this mainboard in any ATX case. Special micro-ATX cases are also available with a reduced number of expansion slot bays and a smaller power supply unit. Ensure that your case has an I/O cover plate that matches the ports on this mainboard. Install the mainboard in a case. Follow the instructions provided by the case manufacturer using the hardware and internal mounting points on the chassis.

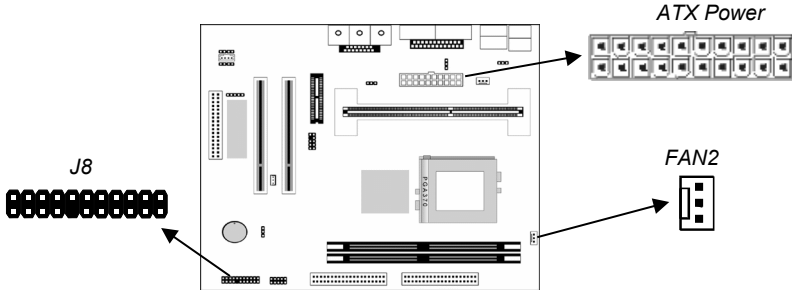

Connect the power connector from the power supply to the **ATX** Power connector on the mainboard. If there is a cooling fan installed in the system chassis, connect the cable from the cooling fan to the **FAN2** fan power connector on the mainboard. Connect the case switches and indicator LEDs to the **J8** switch and LED connector header. See the illustration below for a guide to the J8 connector pin assignments.

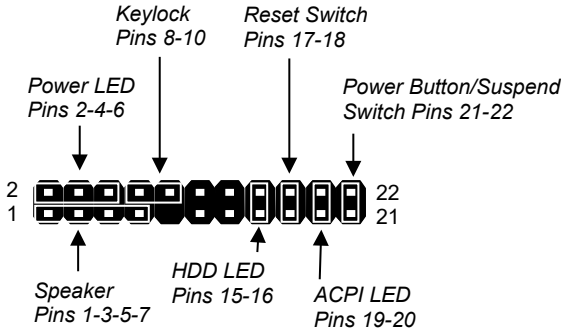

Mainboard User's Manual

Install the Extension Brackets

The extension brackets are used to connect features on the mainboard to external connectors that can be attached to the system chassis. Follow the steps below to install the extension brackets.

Note: All the ribbon cables used on the extension brackets have a red stripe on the Pin-1 side of the cable.

LAN Adapter Extension Bracket

This bracket supports an RJ45 network connector and connects to the built in LAN header on the mainboard.

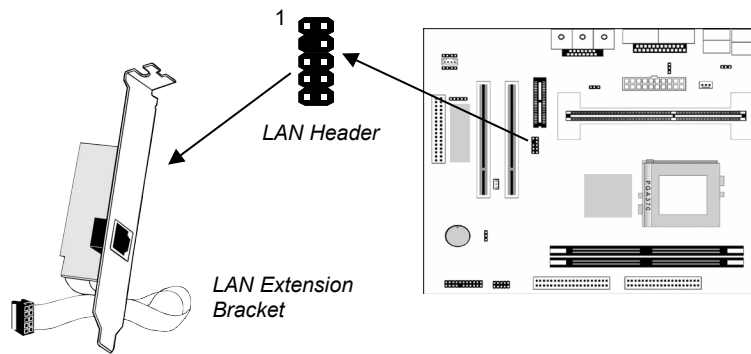

1. On the mainboard, locate the LAN header for this bracket.
2. Plug the cable from the bracket into the LAN header.
3. In the system chassis, remove a blanking plate from one of the expansion slots and install the extension bracket in the slot. Use the screw that held the blanking plate in place to secure the extension bracket.

1: Introduction

Optional Extension Brackets

For this mainboard, you can also obtain an USB module extension bracket. Install them by following the steps below.

Extended USB Module

This module bracket has two USB ports for more USB devices.

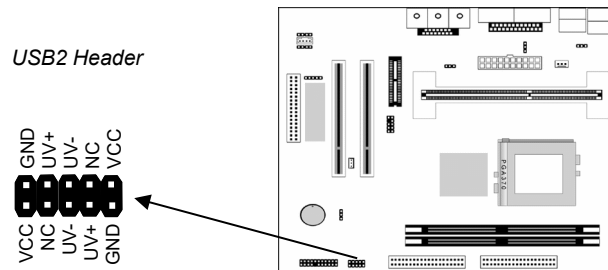

1. Locate the **USB2** header on the mainboard.
2. Plug the bracket cable onto the header.
3. In the system chassis, remove a slot cover from one of the expansion slots and install the extension bracket in the opening. Use the screw that held the slot cover in place to secure the extension bracket to the chassis.

Mainboard User's Manual

Install Other Devices

Install and connect any other devices in the system following the steps below.

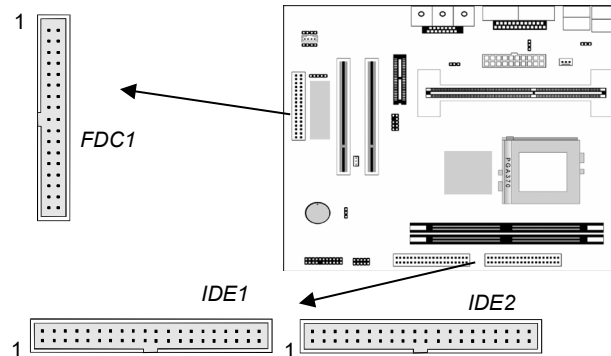

Floppy Disk Drive

The mainboard ships with a floppy disk drive cable that can support one or two drives. Drives can be 3.5" or 5.25" wide, with capacities of 360K, 720K, 1.2MB, 1.44MB, or 2.88MB.

Install your drives and connect power from the system power supply. Use the cable provided to connect the drives to the floppy disk drive header **FDC1**.

IDE Devices

IDE devices include hard disk drives, high-density diskette drives, and CD-ROM or DVD-ROM drives, among others.

The mainboard ships with an IDE cable that can support one or two IDE devices. If you connect two devices to a single cable, you must configure one of the drives as Master and one of the drives as Slave. The documentation of the IDE device will tell you how to configure the device as a Master or Slave device. The Master device connects to the end of the cable.

Install the device(s) and connect power from the system power supply. Use the cable provided to connect the device(s) to the Primary IDE channel connector **IDE1** on the mainboard.

1: Introduction

If you want to install more IDE devices, you can purchase a second IDE cable and connect one or two devices to the Secondary IDE channel connector **IDE2** on the mainboard. If you have two devices on the cable, one must be Master and one must be Slave.

Internal Sound Connections

If you have installed a CD-ROM drive or DVD-ROM drive, you can connect the drive audio cable to the onboard sound system. On the mainboard, locate the two 4-pin connectors **CD1** and **CD2**. There are two kinds of connector because different brands of CD-ROM drive have different kinds of audio cable connectors. Connect the cable to the appropriate connector.

If you have installed a secondary CD-ROM drive or DVD-ROM drive, you can connect the drive audio cable to the onboard sound system. On the mainboard, locate the 4-pin Aux-In header **AUX1**, connect the cable to the connector.

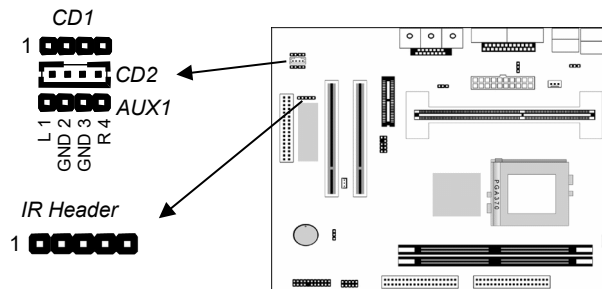

Infrared Port

You can connect an infrared port to the mainboard. You can purchase this option from third-party vendors.

1. Locate the infrared port IR header on the mainboard.
2. If you are adding an infrared port, connect the ribbon cable from the port to the IR header and then secure the port to an appropriate place in your system chassis.

Mainboard User's Manual

Expansion Slots

This mainboard has two 32-bit PCI expansion slots and one AMR slot.

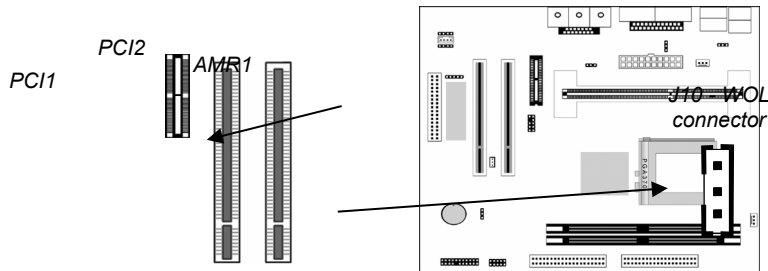

Follow the steps below to install a PCI/AMR expansion card.

1. Select a free PCI/AMR slot.
2. Remove the slot cover for the expansion slot from the system chassis.
3. Insert the expansion card edge connector into the slot and press it firmly down into it so that it is fully inserted.
4. Secure the expansion card bracket to the system chassis using the screw that held the slot cover in place.

AMR Slot

The AMR (Audio Modem Riser) slot is an industry standard slot that allows for the installation of a special audio/modem riser card. Different territories have different regulations regarding the specifications of a modem card. You can purchase an AMR card that is approved in your area and install it directly into the AMR slot.

Wake On LAN (WOL)

If you are using an ATX power supply you can configure your system so that it powers down by software and can be resumed by alarms. If you have installed a LAN adapter expansion card, connect the card to the Wake On LAN connector **J10**. This allows incoming traffic to resume the system from a software power down. You need to enable this feature in the system setup utility.

Chapter 3

BIOS Setup Utility

Introduction

The BIOS Setup Utility records settings and information about your computer such as the date and time, the kind of hardware installed, and various configuration settings. Your computer uses this information to initialize all the components when booting up and functions as the basis for coordination between system components.

If the Setup Utility configuration is incorrect, it may cause the system to malfunction. It can even stop your computer from booting properly. If this happens, you can use the clear CMOS jumper to clear the CMOS memory used to store the configuration information, or you can hold down the **Page Up** key while you reboot your computer. Holding down the **Page Up** key also clears the CPU PnP Setup information, you may need to set the CPU speed again.

You can run the setup utility and manually make changes to the configuration. You might need to do this to configure some of the hardware that you install on or connect to the mainboard, such as the CPU, system memory, disk drives, etc.

Mainboard User's Manual

Running the Setup Utility

Each time your computer starts, before the operating system loads, a message appears on the screen that prompts you to “Hit if you want to run SETUP”. When you see this message, press the **Delete** key and the Main menu page of the Setup Utility appears on your monitor.

AMIBIOS SIMPLE SETUP UTILITY - VERSION 1.20 (C)1998 American Megatrends, Inc. All Rights Reserved			
Standard CMOS Setup		Features Setup	
Advanced Setup		CPU PnP Setup	
Power Management Setup		Hardware Monitor	
PCI / Plug and Play Setup		Change Password	
Load Optimal Settings		Exit	
Load Best Performance Settings			
ESC: Quit	F4↔: Select Item	(Shift)F2: Change Color	F5: Old Values
F6: Optimal values	F7: Best performance values	F10: Save&Exit	
Standard CMOS setup for changing time, date, hard disk type, etc.			

You can use the cursor arrow keys to highlight any of the options on the main menu page. Press **Enter** to select the highlighted option. To leave the setup utility, press the **Escape** key. To cycle through the Setup Utility's optional color schemes hold down the **Shift** key and press **F2**.

Some of the options on the main menu page lead to tables of items with installed values. In these pages, use the cursor arrow keys to highlight the items, and then use the **PgUp** and **PgDn** keys to cycle through the alternate values for each of the items. Other options on the main menu page lead to dialog boxes which require you to answer Yes or No by hitting the **Y** or **N** keys.

If you have already made changes to the setup utility, press **F10** to save those changes and exit the utility. Press **F5** to reset the changes to the original values. Press **F6** to install the setup utility with a set of default values. Press **F7** to install the setup utility with a set of high-performance values.

3: BIOS Setup Utility

Standard CMOS Setup Page

Use this page to set basic information such as the date and time, the IDE devices, and the diskette drives. If you press the F3 key, the system will automatically detect and configure the hard disks on the IDE channels.

AMIBIOS SETUP - STANDARD CMOS SETUP												
<C>1998 American Megatrends, Inc. All Rights Reserved												
Date (mm/dd/yyyy): Thu Dec 02, 1999												
Time (hh/mm/ss) : 23:27:20												
	Type	Size	Cyln	Head	WPcon	Sec	LBA	Blk	PIO	32Bit		
Pri Master	: Not Installed											
Pri Slave	: Not Installed											
Sec Master	: Not Installed											
Sec Slave	: Not Installed											
Floppy Drive A: Not Installed												
Floppy Drive B: Not Installed												
Month:	Jan - Dec						ESC	:	Exit			
Day:	01 - 31						F4	:	Select Item			
Year:	1901 - 2099						FU/PD/+/-	:	Modify			
							<Shift>F2	:	Color			
							F3	:	Detect All HDD			

Date & Time	Use these items to set the system date and time
Pri Master	Use these items to configure devices connected to the Primary and Secondary IDE channels. To configure an IDE hard disk drive, choose <i>Auto</i> . If the <i>Auto</i> setting fails to find a hard disk drive, set it to <i>User</i> , and then fill in the hard disk characteristics (Size, Cyls, etc.) manually. If you have a CD-ROM drive, select the setting <i>CDROM</i> . If you have an ATAPI device with removable media (e.g. a ZIP drive or an LS-120) select <i>Floptical</i> .
Pri Slave	
Sec Master	
Sec Slave	
Floppy Drive A Floppy Drive B	Use these items to set the size and capacity of the floppy diskette drive(s) installed in the system.

Mainboard User's Manual

Advanced Setup Page

Use this page to set more advanced information about your system. Take some care with this page. Making changes can affect the operation of your computer.

AMIBIOS SETUP – ADVANCED SETUP (C) 2000 American Megatrends, Inc. All Rights Reserved		
Trend ChipAway Virus	Enabled	ESC : Quit ↑↓←→ : Select Item F1 : Help PU/PD/+/- : Modify F5 : Old Values (Shift)F2 : Color F6 : Load Optimal values F7 : Load Best performance values
Frame Buffer Cache Control	Auto	
Share Memory Size	16M	
1 st Boot Device	IDE-0	
2 nd Boot Device	Floppy	
3 rd Boot Device	CDROM	
Try Other Boot Devices	Yes	
S.M.A.R.T. for Hard Disks	Disabled	
BootUp Num-Lock	On	
Floppy Drive Swap	Disabled	
Floppy Drive Seek	Disabled	
PS/2 Mouse Support	Enabled	
Password Check	Setup	
Boot To OS/2 > 64MB	No	
Internal Cache	Enabled	
System BIOS Cacheable	Enabled	
CAS Latency	3T	

Trend ChipAway Virus	This mainboard has built-in virus protection in the firmware. Use this item to enable or disable the built-in virus protection.
Frame Buffer Cache Control	This item appears when a Frame Buffer Cache card is installed in the ADIMM socket. The default setting, Auto, automatically sets the display memory size. The Manual setting uses the next item to manually set display memory size.
Share Memory Size	This item lets you allocate a portion of the main memory for use by the onboard VGA display.
1st Boot Device 2nd Boot Device 3rd Boot Device	Use these items to determine the device order the computer uses to look for an operating system to load at start-up time.
Try Other Boot Device	If you enable this item, the system will also search for other boot devices if it fails to find an operating system from the first two locations.
S.M.A.R.T. for Hard Disks	Enable this item if any IDE hard disks support the S.M.A.R.T. (Self-Monitoring, Analysis and

3: BIOS Setup Utility

	Reporting Technology) feature.
BootUp Num-Lock	This items determines if the Num Lock key is active or inactive at system start-up time.
Floppy Drive Swap	If you have two diskette drives installed and you enable this item, drive A becomes drive B and drive B becomes drive A.
Floppy Drive Seek	If you enable this item, your system will check all floppy disk drives at start up. Disable this item unless you are using an old 360KB drive.
PS/2 Mouse Support	If this item is set to Enabled, the onboard PS/2 Mouse port will work. Setting this to Disable turns off the port.
Password Check	If you have entered a password for the system, use this item to determine if the password is required to enter the Setup Utility (<i>Setup</i>) or required both at start-up and to enter the Setup Utility (<i>A/ways</i>).
Boot to OS/2 > 64MB	Enable this item if you are booting the OS/2 operating system and you have more than 64MB of system memory installed.
Internal Cache	Leave this item enabled since all the processors that can be installed on this board have internal cache memory.
System BIOS Cacheable	If you enable this item, a segment of the system BIOS will be cached to main memory for faster execution.
CAS Latency	This item determines the operation of the SDRAM memory CAS (column address strobe). We recommend that you leave this item at the default value. The 2T setting requires faster memory that specifically supports this mode.

Mainboard User's Manual

Power Management Setup Page

This page sets some of the parameters for system power management operation.

AMIBIOS SETUP – POWER MANAGEMENT SETUP (C) 2000 American Megatrends, Inc. All Rights Reserved		
Power Management/APM	Disabled	ESC : Quit ↑↓←→ : Select Item F1 : Help PU/PD/+/- : Modify F5 : Old Values (Shift)F2 : Color F6 : Load Optimal values F7 : Load Best performance values
Standby Time Out (Minute)	Disabled	
Suspend Time Out (Minute)	Disabled	
Hot Key Power On	Disabled	
OnBoard LAN Card Power On	Disabled	
Ring On Power On	Disabled	
RTC Alarm Power On	Disabled	
RTC Alarm Date	Every Day	
RTC Alarm Hour	12	
RTC Alarm Minute	30	
RTC Alarm Second	30	

Power Management/APM	Use this item to enable or disable a power management scheme. If you enable power management, you can use the items below to set the power management operation. Both APM and ACPI are supported.
Standby Time Out (Minute)	This sets the timeout for Standby mode in minutes. If the time selected passes without any system activity, the computer will enter power-saving Standby mode.
Suspend Time Out (Minute)	This sets the timeout for Suspend mode in minutes. If the time selected passes without any system activity, the computer will enter power-saving Suspend mode.
Hot Key Power On	If you enable this item, you can turn the system on by pressing hot keys (Ctrl + Alt + BackSpace) on the keyboard. You must connect an ATX power supply and enable this function jumper in order to use this feature.
OnBoard LAN Card Power On	The system can be turned off with a software command. If you enable this item, the system can automatically resume if there is traffic on the network adapter. You must use an ATX power supply in order to use this feature.

3: BIOS Setup Utility

Ring On Power On	The system can be turned off with a software command. If you enable this item, the system can automatically resume if there is an incoming call on the Fax/Modem. You must use an ATX power supply in order to use this feature.
-------------------------	----------------------------------------------------------------------------------------------------------------------------------------------------------------------------------------------------------------------------------

RTC Alarm Power On	The system can be turned off with a software command. If you enable this item, the system can automatically resume at a fixed time based on the system's RTC (realtime clock). Use the items below this one to set the date and time of the wake-up alarm. You must use an ATX power supply in order to use this feature.
---------------------------	---------------------------------------------------------------------------------------------------------------------------------------------------------------------------------------------------------------------------------------------------------------------------------------------------------------------------

Mainboard User's Manual

PCI / Plug and Play Setup Page

This page sets some of the parameters for devices installed on the PCI bus and devices that use the system plug and play capability.

AMIBIOS SETUP - PCI / PLUG AND PLAY SETUP	
(C)1998 American Megatrends, Inc. All Rights Reserved	
Plug and Play Aware O/S	Yes
Primary Graphics Adapter	PCI
Allocate IRQ to PCI VGA	Yes
Reserved Memory Size	Disabled
Reserved Memory Address	C8000
ESC : Quit ↑↓↔ : Select Item	
F1 : Help PU/PD/+/- : Modify	
F5 : Old Values <Shift>F2 : Color	
F6 : Load BIOS Defaults	
F7 : Load Setup Defaults	

Plug and Play Aware O/S	Enable this item if you are using an O/S that supports Plug and Play such as Windows 95 or 98.
Primary Graphics Adapter	This item indicates if the primary graphics adapter uses the PCI or the AGP bus. The default PCI setting still lets the onboard display work and allows the use of a second display card installed in a PCI slot.
Allocate IRQ to PCI VGA	If this item is enabled, an IRQ will be assigned to the PCI VGA graphics system. You set this value to No to free up an IRQ.
Reserved Memory Size	This item lets you reserve a block of memory for any device that requires it.
Reserved Memory Address	This item lets you set the address for any block of memory that has been reserved.

3: BIOS Setup Utility

Load Optimal Settings

If you select this item and press **Enter** a dialog box appears. If you press **Y**, and then **Enter**, the Setup Utility loads a set of fail-safe default values. These default values are not very demanding and they should allow your system to function with most kinds of hardware and memory chips.

Load Best Performance Settings

If you select this item and press **Enter** a dialog box appears. If you press **Y**, and then **Enter**, the Setup Utility loads a set of best-performance default values. These default are quite demanding and your system might not function properly if you are using slower memory chips or other low-performance components.

Mainboard User's Manual

Features Setup Page

This page sets some of the parameters for peripheral devices connected to the system.

AMIBIOS SETUP – FEATURES SETUP (C) 2000 American Megatrends, Inc. All Rights Reserved		
OnBoard FDC	Enabled	
OnBoard Serial PortA	3F8h/COM1	
OnBoard IR Port	Disabled	
OnBoard Parallel Port	378h	
Parallel Port Mode	SPP	
Parallel Port IRQ	7	
Parallel Port DMA	N/A	
OnBoard Game Port	Auto	
OnBoard MIDI Port	300h	
MIDI Port IRQ	10	
OnBoard PCI IDE	Both	
Ultra DMA Support	Disabled	
OnChip Audio	Enabled	
OnChip Modem	Auto	
OnBoard LAN	Enabled	
USB Function	Disabled	
USB Function for DOS	Disabled	
		ESC : Quit ↑↓←→ : Select Item F1 : Help PU/PD/+/- : Modify F5 : Old Values (Shift)F2 : Color F6 : Load Optimal values F7 : Load Best performance values

OnBoard FDC	Use this item to enable or disable the onboard floppy disk drive interface.
OnBoard Serial PortA	Use this item to enable or disable the onboard COM1 serial port, and to assign a port address
OnBoard IR Port	Use this item to define the protocol for an infrared port if you have installed an optional IR port. The choices are IrDA and ASKIR.
Onboard Parallel Port	Use this item to enable or disable the onboard LPT1 parallel port, and to assign a port address. The Auto setting will detect and available address.
Parallel Port Mode	Use this item to set the parallel port mode. You can select SPP (Standard Parallel Port), ECP (Extended Capabilities Port), EPP (Enhanced Parallel Port), or ECP + EPP.
Parallel Port IRQ	Use this item to assign either IRQ 5 or 7 to the parallel port.
Parallel Port DMA	Use this item to assign a DMA channel to the parallel port. The options are 0, 1 and 3.

3: BIOS Setup Utility

OnBoard Game Port	Use this item to enable or disable the onboard game port, and to assign a port address.
OnBoard MIDI Port	Use this item to enable or disable the onboard MIDI port, and to assign a port address.
MIDI Port IRQ	Use this item to assign an IRQ to the MIDI port.
Onboard PCI IDE	Use this item to enable or disable either or both of the onboard Primary and Secondary IDE channels.
Ultra DMA Support	Use this item to set Ultra DMA support for IDE devices on the Primary or Secondary IDE channels. You must enable this or UDMA devices will not work at their intended speed.
OnChip Audio	This item enables or disables the onboard audio chip.
OnChip Modem	This item enables or disables the onboard modem chip.
OnBoard LAN	This item enables or disables the onboard network interface.
USB Function	Enable this item if you plan to use the USB ports on this mainboard.
USB Function for DOS	Enable this item if you plan to use the USB ports on this mainboard in a DOS environment.

Mainboard User's Manual

CPU PnP Setup Page

This page lets you manually configure the mainboard for the CPU. The system will automatically detect the kind of CPU that you have installed and make the appropriate adjustments to the items on this page.

Note: If you manually set the wrong speed and the system won't run properly, press the **Page Up** key while the system is booting and a default setting will replace the incorrect CPU setting.

AMIBIOS SETUP - CPU PnP SETUP	
(C)1998 American Megatrends, Inc. All Rights Reserved	
CPU Speed	400MHZ
CPU/DRAM Freq.	66/66Mhz
CPU Multiplier Freq.	86
ESC : Quit ↑↓↔ : Select Item	
F1 : Help PU/PD/+/- : Modify	
F5 : Old Values <Shift>F2 : Color	
F6 : Load BIOS Defaults	
F7 : Load Setup Defaults	

CPU Speed	The item displays the internal clock speed of the CPU, based on the next two items.
CPU/SDRAM Frequency	Use this item to sets the external clock frequency for the CPU and the memory bus frequency. The options include combinations of 66 and 100MHz. Set the CPU clock based on the requirements of the CPU installed on the board. Select the memory frequency based on the speed of the memory installed on the board.
CPU Multiple Freq.	Use this item to set a multiplier for the CPU external frequency. The multiplier times the external CPU frequency sets the internal clock speed of the CPU, e.g. 100 MHz (external clock or "FSB") x 4.5 (multiplier) = 450 MHz (internal clock speed of the installed CPU).

3: BIOS Setup Utility

Hardware Monitor Page

This page sets some of the parameters for the hardware monitoring function of this mainboard.

AMIBIOS SETUP - HARDWARE MONITOR	
<C>1998 American Megatrends, Inc. All Rights Reserved	
--= Hardware Monitor =--	
Slot 1	30°C/86°F
Socket 370	
FAN#1 Speed	5192 RPM
FAN#2 Speed	5273 RPM
Ucore	2.002 V
+ 1.8000	1.808 V
Ucc3	3.328 V
Ucc	5.026 V
+12V	11.968 V
SBSU	4.999 V
ESC : Quit ↑↓↔ : Select Item	
F1 : Help PU/PD/+/- : Modify	
F5 : Old Values (Shift)F2 : Color	
F6 : Load BIOS Defaults	
F7 : Load Setup Defaults	

Slot 1, Socket 370 These items display CPU temperature measurement. The system will alert you if a safe temperature is exceeded.

FAN#1, 2 Speed & Voltage Measurements These items indicate cooling fan speeds in RPM and the various system voltage measurements. If the values deviate beyond certain limits, the hardware monitoring feature will alert you with a warning.

Note: The CPU temperature appears for the CPU socket used. If the Socket 370 socket is used, a CPU temperature will display on that line instead of the Slot 1 line as shown here.

Mainboard User's Manual

Change Password

If you highlight this item and press **Enter**, a dialog box appears which lets you enter a Supervisor password. You can enter no more than six letters or numbers. Press **Enter** after you have typed in the password. A second dialog box asks you to retype the password for confirmation. Press **Enter** after you have retyped it correctly. The password is then required to access the Setup Utility or for that and at start-up, depending on the setting of the Password Check item in Advanced Setup.

Change or Remove the Password

Highlight this item, press **Enter** and type in the current password. At the next dialog box, type in the new password, or just press **Enter** to disable password protection.

Exit

Highlight this item and press **Enter** to save the changes that you have made in the Setup Utility configuration and exit the program. When the Save and Exit dialog box appears, press **Y** to save and exit, or press **N** to exit without saving.

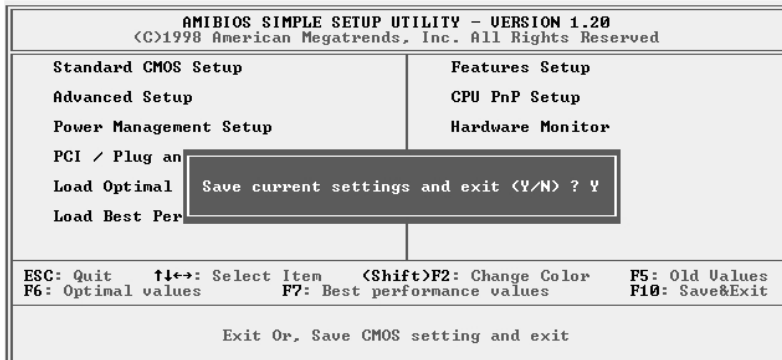

Chapter 4

Software & Applications

Introduction

The support software CD-ROM that is included in the mainboard package contains all the drivers and utility programs needed to properly run our products. Below you can find a brief description of each software program, and the location for your mainboard version. More information on some programs is available in a README file, located in the same directory as the software.

If the operating system used in your system is Windows 98, it will automatically install all the drivers and utilities for your board. See the Installing under Windows 98 section.

Installing Support Software

The software on the support CD-ROM is for Windows 95/NT/2000 and Windows 98/Me. The installation procedure differs depending on which Operating System you have, but the automatic installation is now for Win98/Me only.

Installing Under Windows 95/NT/2000

To install support software for Windows 95/NT/2000 follow this general procedure:

1. Insert the support CD-ROM disc in the CD-ROM drive.
(The system might get an error message from the PnP function. Don't care the message. You don't really need that file to install the drivers)
2. Use My Computer or Windows Explorer to look at the directory structure. You must use the Open command in the right-button menu. Double-clicking on the drive icon will result in an error message because the disc's AutoRun feature doesn't work in Windows 95/NT/2000.
3. Execute the EXE file name given in the description below.

Mainboard User's Manual

*Note: The correct path name for each software driver is provided, where **D:** identifies the CD-ROM drive letter – modify if necessary.*

Bus Master IDE Driver

The IDE Bus Master Drivers allows the system to properly manage the IDE channels on the mainboard. You only need to install an IDE driver if you are running Windows 95. Use the default Windows driver on the Windows CD-ROM disc.

Display Drivers and Software

Find the Display drivers and software here:

- ◆ D:\VGA\SiS630\

Audio Driver

The Audio driver allows the system to use the onboard audio circuitry. Find the driver and audio application here:

- ◆ D:\SOUND\Driver\SiS\
- ◆ D:\SOUND\Gamut\

Network Adapter Driver

Find the network interface driver here:

- ◆ D:\LAN\SiS900

USB Driver

The USB Driver allows the system to recognize the USB ports on the mainboard. You need to install this driver if you are running Windows 95. Windows 95 OSR2 does not require this driver.

This driver is available for:

- ◆ Win95 – D:\USB\EUSBSUPP\USBSUPP.EXE
- ◆ Win95 (Chinese) – D:\USB\CUSBSUPP\CUSBSUPP.EXE

3Deep Software

Find the software here:

- ◆ D:\3Deep\3Deep 3.3\Setup.EXE

AMR Modem Driver

Find the driver here:

- ◆ D:\Modem\Driver\AMR\PCtel\

4: Software & Applications

BIOS Update Utility

The BIOS Update utility allows you to update the BIOS file on the mainboard to a newer version. You can download the latest version of the BIOS setup available for your mainboard from the website.

- ◆ D:\UTILITY\AMINF324.EXE

PC-Cillin Software

The PC-cillin software program provides anti-virus protection for your system.

This program is available for:

- ◆ DOS – D:\PC-CILLIN\DOS\PCSCAN.EXE
- ◆ Windows 9x – D:\PC-CILLIN\WIN98\SETUP.EXE

Installing Under Windows 98

The support software CD-ROM disc loads automatically under Windows 98/Me. When you insert the CD-ROM disc in the system CD-ROM drive the Autorun feature will automatically bring up the install screen. The screen has three buttons on it, Setup, Browse CD and Exit. See the following screen illustration.

When you click on the **Setup** button the software installation program will run and you can select what kind of installation you want to do, as explained later in this section.

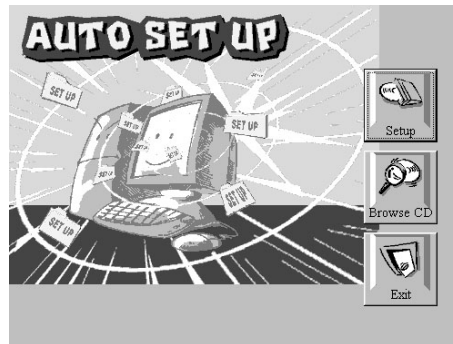

Mainboard User's Manual

The **Browse CD** button is the standard Windows command that allows you to examine the contents of the disc using the Windows 98 file browsing interface.

The **Exit** button closes the Auto Setup window. To run the program again, reinsert the CD-ROM disc in the drive or click on AutoRun in the context sensitive menu for the CD-ROM drive icon in a file browser window.

Installing Software with Auto Setup

To install support software for the system board follows this procedure:

1. Click on the **Setup** button. The install program will load and display the following screen. Click the **Next** button.



2. Select the items that you want to setup by clicking on it (the default options are recommended). Click the **Next** button to proceed.

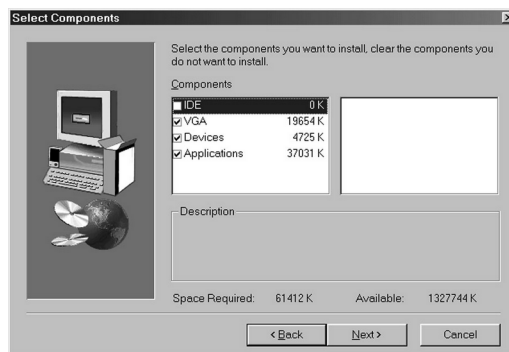

4: Software & Applications

3. The support software will automatically install.

Once any of the installation procedures start, software is automatically installed in sequence. You will need to follow the onscreen instructions, confirm commands and allow the computer to restart as few times as is needed to complete installing whatever software you selected to install. When the process is finished, all the support software will be installed and working.

There are some utilities that you have to manually install if you need, check to the above section.