

LI6BM
Pentium II 440BX/Apollo Pro Plus
JumperFree Motherboard

User's Manual

Version 1.0



The brand names, product names and trade names in this manual are trademarks or registered trademarks of their respective holders.

This publication is protected by copyright and all rights are reserved. No part of it may be reproduced or transmitted by any means or in any form, without prior consent in writing from the manufacturer.

The information in this document has been carefully checked and is believed to be accurate. However, the manufacturer assumes no responsibility for any inaccuracies that may appear in this manual. In no event will the manufacturer be liable for direct, indirect, special, exemplary, incidental or consequential damages resulting from any defect or omission in this manual, even if advised of the possibility of such damages. The material contained herein is for informational purposes only.

Contents

Chapter 1 Introduction.....	1
Chapter 2 Specifications.....	3
Chapter 3 Hardware Description.....	7
3.1 Processor.....	9
3.2 L2 Cache.....	9
3.3 BIOS.....	9
3.4 Main Memory.....	10
3.5 I/O Port Address Map.....	11
3.6 DMA Channels.....	11
3.7 Onboard PCI-IDE.....	11
3.8 Interrupt Request (IRQ) Lines.....	12
3.9 Onboard Multi-I/O.....	12
3.10 Onboard VGA.....	13
3.11 Onboard Audio.....	13
3.12 Onboard Ethernet Controller (option).....	14
3.13 Hardware Monitoring IC.....	14
Chapter 4 Configuring the Motherboard.....	15
4.1 CPU Frequency Selection.....	17
4.2 Keyboard Power On Function: JP8, J10.....	17
4.3 Clear CMOS Select: JP11.....	18
4.4 TV-Out Hardware Compliance Setting: JP12.....	18
4.5 CPU Host Frequency Force Selector: JP3.....	18
Chapter 5 Installation.....	19
5.1 I/O Connectors.....	21
5.2 J1: S-VHS Connector.....	21
5.3 J2: RCA Connector.....	21
5.4 J3: Panel Link Connector (option).....	22
5.5 J4: CRT Connector.....	22
5.6 J5: USB Connector.....	23
5.7 J6: PS/2 Keyboard and PS/2 Mouse Connectors.....	23
5.8 J7: Serial Ports.....	24
5.9 J8: Parallel Port Connector.....	24
5.10 J9: RJ45 Connector (option).....	25
5.11 J10, J11, J12: Line Out, Line In, Mic Connectors.....	25

5.12	J22: Game Port Connector.....	25
5.13	J14: AMC Connector.....	26
5.14	J15: CPU Fan Power Connector.....	26
5.15	J16: Chassis Fan Power Connector.....	27
5.16	J17: BL21PI Riser Card Connector.....	27
5.17	J18: IrDA Connector.....	27
5.18	J19: Front Bezel Connectors.....	27
5.19	J20: Floppy Drive Connector.....	28
5.20	J21: ATX Power Supply Connector.....	28
5.21	J23, J24: IDE1 and IDE2 Connectors.....	29
5.22	J25, J26: CD-ROM Audio In Connectors.....	30
5.23	J27: Auxiliary Audio In Connector.....	30
Chapter 6 BIOS and System Setup.....		31
6.1	BIOS Introduction.....	34
6.2	BIOS Setup.....	34
6.3	Standard CMOS Setup.....	36
6.4	BIOS Features Setup.....	39
6.5	Chipset Features Setup.....	43
6.6	Power Management Setup.....	46
6.7	PNP/PCI Configuration.....	50
6.8	Load BIOS Defaults.....	53
6.9	Load Setup Defaults.....	53
6.10	CPU Speed Setting / CPU Features Setup.....	54
6.11	Integrated Peripherals.....	57
6.12	Supervisor / User Password.....	60
6.13	IDE HDD Auto Detection.....	61
6.14	Save & Exit Setup.....	62
6.15	Exit Without Saving.....	62
Chapter 7 Audio Driver Installation Guide.....		63
Chapter 8 VGA Driver Installation Guide.....		73
Chapter 9 LAN Driver Installation Guide.....		79
Chapter 10 System Monitor Utility User's Guide.....		95
Appendix.....		102
A.	Slot 1 Retention Mechanism.....	102
B.	Technical Information regarding TV-Out.....	103
C.	Additions & Errata.....	104

Chapter 1 Introduction

This manual is designed to give you information on the LI6BM motherboard. It is divided into the following sections:

- **Introduction**
- **Specifications**
- **Hardware Description**
- **Configuring the Motherboard**
- **Installation**
- **BIOS and System Setup**
- **Audio Driver Installation Guide**
- **VGA Driver Installation Guide**
- **LAN Driver Installation Guide**
- **System Monitor Utility User's Guide**

The LI6BM comes in five variations: LI6BM, LI6BMW, LI6BMN, LI6BMNP, and LI6BMP. The following table shows the main differences among the three models.

	LI6BM	LI6BMW	LI6BMN
Chipset	Intel 440BX	Intel 440BX	Intel 440BX
Panel Link	No	Yes	No
Ethernet	No	Intel 82558B	Intel 82558B
Audio	Yes	Yes	Yes
VGA	Yes	Yes	Yes

	LI6BMNP	LI6BMP	Remarks
Chipset	Apollo Pro Plus	Apollo Pro Plus	W: full function
Panel Link	No	No	N: LAN on board
Ethernet	Intel 82558B	No	P: Apollo Pro Plus
Audio	Yes	Yes	
VGA	Yes	Yes	

Checklist

Please check that your package is complete and contains the items below. If you discover damaged or missing items, please contact your dealer.

- The LI6BM Motherboard with the BL21PI Riser Card
- 1 40-pin IDE ribbon cable (14 cm)
- 1 40-pin CD-ROM ribbon cable (8 cm)
- 1 34-pin FDD ribbon cable (20 cm)
- 1 16-pin game port cable
- 1 CD containing *System Monitor* utility, PIIx4 Bus Master IDE driver and utilities. *Intel's LANDesk Client Manger* software is optional.

Chapter 2 Specifications

The LI6BM is a high-performance Pentium® II motherboard that offers flexibility in terms of CPU frequency and bus speeds. The main features of the motherboard consist of the following:

CPU Socket

Slot 1

Processor

Intel Pentium II 233/266/300MHz (66MHz / Klamath)

Intel Pentium II 333MHz (66MHz / Deschutes)

Intel Pentium II 300/350/400/450/500MHz (100MHz / Deschutes)

Intel Celeron 266/300/300A/333MHz (66MHz)

Intel Katmai 450/500MHz (100MHz)

L2 Cache

CPU integrated L2 cache

CPU Voltage

Switching voltage regulator on board supporting multiple voltage ranging 1.8V-3.5V

Main Memory

64MB SDRAM on board and two 168-pin DIMM sockets

Memory types: SDRAM (Synchronous DRAM)

Maximum memory configuration: 320MB

- NOTE:**
1. Only use SDRAM modules that support SPD (Serial Presence Detect).
 2. Use PC100 modules when running 100MHz CPU bus speed and use PC66 modules when running 66MHz CPU bus speed.

Chipset

Intel 82440BX or VIA Apollo Pro Plus (82C693) with built-in PCI-IDE

Year 2000 Compliant BIOS

The onboard Award BIOS is Year 2000 Compliant and will pass software applications that have the tendency to invoke INT1AH function 04H such as year2000.exe utility released by NSTL. The BIOS comes with ISA Plug and Play (PnP) extension, DMI, bootable CD-ROM and power-management features.

Power Connector

ATX power supply connector (*Use an ATX power supply with 3.3V power.*)

Onboard Audio

The onboard audio consists of the Creative Labs ES1373 Chip + AC97. With a PCI Bus Mastering interface with DOS compatibility, it supports 32 voices wavetable, surround sound, 3D audio, and audio effects such as reverb and chorus. Creative Labs ES1373 uses single, shareable PCI interrupt and is PC97 compliant. AMC operation consists of a 16-bit, bi-directional video port that allows direct connection to popular video upgrades such as video capture/video conferencing, hardware MPEG-2/DVD player, TV tuner with Intercast support and interface to ATI's ImpacTV chip.

Onboard VGA

The onboard *ATI 3D RAGE LT PRO* utilizes AGP (Accelerated Graphics Port) bus to achieve rich 3D and video graphics display. It enables 3D graphics capabilities including support for z-buffering, alpha blending and faster texture mapping. Onboard TV-out connectors support S-VHS and RCA specifications.

Panel Link Support (option)

The optional panel link connector supports the new industry-standard digital video interface called digital flat panel port (DFPP). It allows connection to a flat panel monitor with over several meters of cable without the need for analog-to-digital conversion. It is also compatible with VESA standards such as VESA Display Data Channel (DDC) and VESA Extended Display Identification Data (EDID).

Onboard Ethernet Controller (option)

The onboard Intel 82558B Ethernet controller is compatible with both the traditional 10Mbps and advanced 100Mbps LAN facilities. An RJ45 connector and Wake on LAN are supported by LI6BM.

Hardware Monitoring

The Winbond 83781D Hardware Monitor IC checks system parameters such as CPU temperature, system temperature, voltage levels, CPU fan and chassis fan speeds in order to prevent system hang-ups even before they happen. The IC is used in conjunction with the bundled System Monitor utility. The LANdesk Client Manager software CD is optional.

DMI BIOS Support

Desktop Management Interface (DMI) allows users to download system hardware-level information such as CPU type, CPU speed, internal/external frequencies and memory size.

PCI Bus Master IDE Controller (Ultra DMA/33)

Supports two connectors for up to four IDE devices in two channels such as Tape Backup and CD-ROM drives, PIO Mode 3/4 and Bus Mastering Ultra DMA/33.

Super I/O

Onboard super I/O is a Winbond W83977TF that provides:

- Two 16550 UART compatible serial ports
- One parallel port (ECP/EPP compatible)
- One floppy controller (2.88MB compatible)
- One IrDA port
- Keyboard Controller (**keyboard power-on supported**)

Keyboard and Mouse Connectors

PS/2 type

USB Connector

2 ports onboard

Win95-shut-off

Allows shut-off control from within Windows 95

Modem-ring-on

Supports PC powering on through an external modem.

Expansion Slots on Riser Card BL21PI

Two PCI 32-bit slots

One ISA 16-bit slot

Board Dimensions

11.93" x 12.48" (30.3cm x 31.7cm)

This page was intentionally left blank.

Chapter 3 Hardware Description

This chapter briefly describes each of the major features of the LI6BM motherboard. The layout of the board in Figure 1 shows the location of the key components. The topics covered in this chapter are as follows:

3.1 Processor.....	10
3.2 L2 Cache.....	10
3.3 BIOS.....	10
3.4 Main Memory.....	11
3.5 I/O Port Address Map.....	12
3.6 DMA Channels.....	12
3.7 Onboard PCI-IDE.....	12
3.8 Interrupt Request (IRQ) Lines.....	13
3.9 Onboard Multi-I/O.....	13
3.10 Onboard VGA.....	14
3.11 Onboard Audio.....	14
3.12 Onboard Ethernet Controller (option).....	15
3.13 Hardware Monitoring IC.....	15

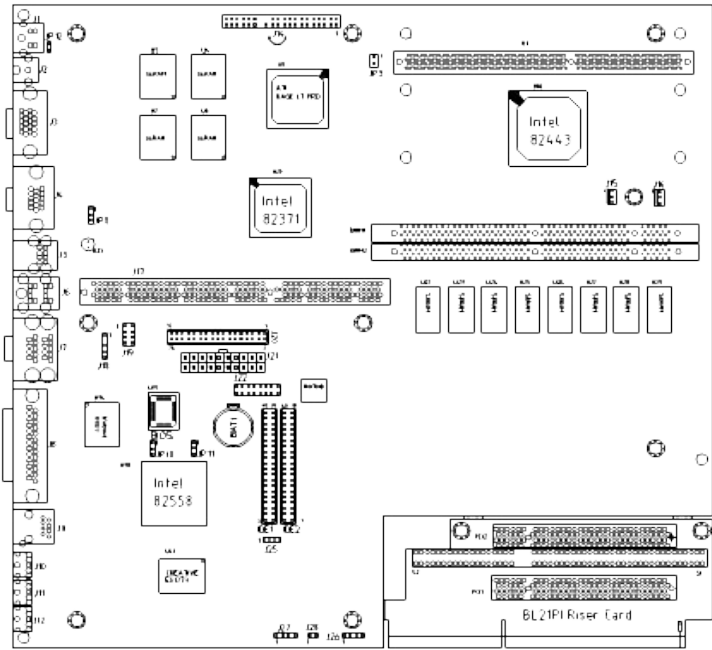

Figure 1: Layout of the LI6BM Motherboard

3.1 Processor

The LI6BM motherboard is designed to take a Pentium II processor running 233MHz/266MHz/300/333MHz at 66MHz CPU bus speed or 300/350/400/450/500MHz at 100MHz CPU bus speed with its Slot 1 processor connector.

3.2 L2 Cache

The L2 cache is integrated in the Pentium II processor. The private L2 cache bus is not connected to package pins; rather its signals are routed between the two cavities using standard package techniques.

3.3 BIOS

The BIOS on the LI6BM motherboard provides the standard BIOS functions plus the following additional features:

1. ISA Plug and Play (PnP) Extension

Unlike PCI cards that are Plug and Play, ISA cards require setting jumpers to resolve hardware conflicts. To make a computer system PnP, an ISA PnP standard is established and supported by new operating systems, such as Windows 95. Under Windows 95, the motherboard BIOS must have an ISA PnP extension to support new ISA PnP cards.

2. Power Management

The power management feature provides power savings by slowing down the CPU clock, turning off the monitor screen and stopping the HDD spindle motor. The BIOS fully conforms to ACPI (Advanced Configuration and Power Interface) specification.

3.4 Main Memory

The LI6BM motherboard supports 64MB of DRAM memory on board and two 168-pin DIMM (Dual In-line Memory Module) sockets to form an additional memory of 256MB. Refer to the following table on how to configure the memory.

168-pin DIMM (3.3V) SDRAM

Onboard DRAM	DIMM1	DIMM2	Total Memory
64MB	-----	-----	64MB
64MB	8MB	-----	72MB
64MB	8MB	8MB	80MB
64MB	8MB	16MB	88MB
64MB	8MB	32MB	104MB
64MB	8MB	64MB	136MB
64MB	8MB	128MB	200MB
64MB	16MB	-----	80MB
64MB	16MB	16MB	96MB
64MB	16MB	32MB	112MB
64MB	16MB	64MB	144MB
64MB	16MB	128MB	208MB
64MB	32MB	-----	96MB
64MB	32MB	32MB	128MB
64MB	32MB	64MB	160MB
64MB	32MB	128MB	224MB
64MB	64MB	-----	128MB
64MB	64MB	64MB	192MB
64MB	64MB	128MB	256MB
64MB	128MB	-----	192MB
64MB	128MB	128MB	320MB
64MB	256MB	-----	320MB
64MB	256MB	256MB	576MB

For 440BX only

NOTE: Use SDRAM modules with PC100 specification when running 100MHz CPU bus speed. With 66MHz CPU bus speed, SDRAM modules with PC66 or PC100 specification can be used.

3.5 I/O Port Address Map

Each peripheral device in the system is assigned a set of I/O port addresses, which also becomes the identity of the device. There is a total of 1K port address space available. The following table lists the I/O port addresses used on the motherboard.

Address	Device Description
000h - 01Fh	DMA Controller #1
020h - 03Fh	Interrupt Controller #1
040h - 05Fh	Timer
060h - 06Fh	Keyboard Controller
070h - 07Fh	Real Time Clock,, NMI
080h - 09Fh	DMA Page Register
0A0h - 0BFh	Interrupt Controller #2
0C0h - 0DFh	DMA Controller #2
0F0h	Clear Math Coprocessor Busy Signal
0F1h	Reset Math Coprocessor
1F0h - 1F7h	IDE Interface
2F8h - 2FFh	Serial Port #2(COM2)
378h - 3FFh	Parallel Port #1(LPT1)
3F0h - 3F7h	Floppy Disk Controller
3F8h - 3FFh	Serial Port #1(COM1)

3.6 DMA Channels

There are seven DMA channels available on the motherboard. Only DMA2 is used by the floppy controller. In the case that ECP mode on the parallel port is utilized, DMA1 or DMA3 will be used.

3.7 Onboard PCI-IDE

The PCI-IDE controller is a part of the Intel 82440BX or VIA Apollo Pro Plus (82C693) chipset. It supports PIO mode 3/4 and bus mastering Ultra DMA/33. The peak transfer rate of PIO mode 3/4 can be as high as 17MB/sec. Using HDDs that support Ultra DMA/33, the peak transfer rate can reach 33MB/sec. There are two IDE connectors - primary IDE and secondary IDE. With two devices per connector, up to four IDE devices can be supported.

3.8 Interrupt Request (IRQ) Lines

There are a total of 15 IRQ lines available on the motherboard. Peripheral devices use an interrupt request to notify the CPU for the service required. The following table shows the IRQ lines used by the devices on the motherboard:

<u>Level</u>	<u>Function</u>
IRQ0	System Timer Output
IRQ1	Keyboard
IRQ2	Interrupt Cascade
	Real Time Clock
	Software Redirected to Int 0Ah or PCI Slot
Int#	
	Reserved or PCI Slot Int#
	Reserved or PCI Slot Int#
	PS/2 Mouse or PCI Slot Int#
	Co-Processor
	Primary IDE
	Secondary IDE
IRQ3	Serial Port #2
IRQ4	Serial Port #1
IRQ5	Parallel Port #2 or PCI Slot Int#
IRQ6	Floppy Disk Controller
IRQ7	Parallel Port #1

3.9 Onboard Multi-I/O

The onboard multi-I/O chip, W83977TF, supports a keyboard controller (AMI copyright), two serial ports, one parallel port, one floppy controller and one IrDA port. The serial ports are 16550 UART compatible. The parallel port features high-speed EPP/ECP mode. The floppy controller supports up to 2.88 MB format.

The multi-I/O also features **keyboard power-on** that is configured in the Power On Function field of the Integrated Peripherals section in the BIOS. It allows users to enter a password of a maximum of five characters (0~9, A~Z). Hot keys to power on supported are the function keys (Ctrl-F1~Ctrl-F12).

3.10 Onboard VGA

The onboard *3D RAGE LT PRO* is a highly integrated Multimedia/3D Graphics Controller that has the following unique features:

- **TV-Out**
An integrated TV encoder with on-chip triple-DAC allows simultaneous CRT/LCD/TV output.
- **Dual CRT Controller Support**
Two independent CRT controllers support two asynchronous simultaneous displays (LCD/CRT, CRT/TV).
- **Floating-Point Set-up Engine**
The *3D RAGE LT PRO* integrates a floating-point set-up engine capable of processing up to 1.2 million triangles per second. By off-loading the set-up function from the CPU, allowing it to focus on 3D geometry and lighting transformations, the *3D RAGE LT PRO* dramatically improves the performance of the entire 3D pipeline.
- **DVD and Video Support**
DVD and video features include enhanced motion compensation acceleration and a 4-tap horizontal and 2-tap vertical high quality DVD video scaler, providing smooth images without the “jaggies” (jagged edges) common to today’s video products. The scaler provides true color video display, independent of the graphics mode used.
- **AGP 2X mode**
The DVD enabled *3D RAGE LT PRO* AGP 2X support the AGP 2X (133MHz) mode that offers a peak bandwidth in excess of 500MB/s. It supports AGP’s pipeline and sideband protocols critical to the enhanced 3D and video performance.
- **Panel Link Support (option)**
The optional panel link connector supports new compact LCD (Liquid Crystal Display) monitors that not only emit less radiation and consume less power but take less space.

3.11 Onboard Audio

The onboard ES1373 is a Creative Labs AC97 digital controller, which provides the next generation of audio performance to the Sound Blaster™ AudioPCI™ product line. It includes a complete audio recording and playback system. The ES1373 interfaces to the PCI bus and to AC97, an industry standard codec/mixer. This solution is Sound Blaster PCI compatible utilizing a patented method of Sound Blaster emulation. In addition, it is compliant to AC97 interface, Microsoft PC97 and PC98, and Multimedia PC Level II and III specifications.

3.12 Onboard Ethernet Controller (option)

The onboard Intel 82558B Ethernet controller features the following:

- PCI local bus
- IEEE802.3u auto-negotiation for automatic speed selection
- 10/100Mbps operation in a single port PCI bus master architecture
- Wake On LAN function support

3.13 Hardware Monitoring IC



The LI6BM comes with the Winbond W83781D hardware monitoring IC. It monitors several hardware parameters including power supply voltages, fan speeds, and temperatures, which are very important for a high-end computer system to work stable and properly.

Chapter 4 Configuring the Motherboard

The following sections describe the necessary procedures and proper jumper settings to configure the LI6BM motherboard. For the locations of the jumpers, refer to Figure 2.

4.1 CPU Frequency Selection.....	18
4.2 Keyboard Power On Function: JP8, J10.....	18
4.3 Clear CMOS Select: JP11.....	20
4.4 TV-Out Hardware Compliance Setting: JP12.....	20
4.5 CPU Host Frequency Force Selector: JP3.....	20

The following examples show the conventions used in this chapter.

	Jumper Open
	Jumper Closed/Short

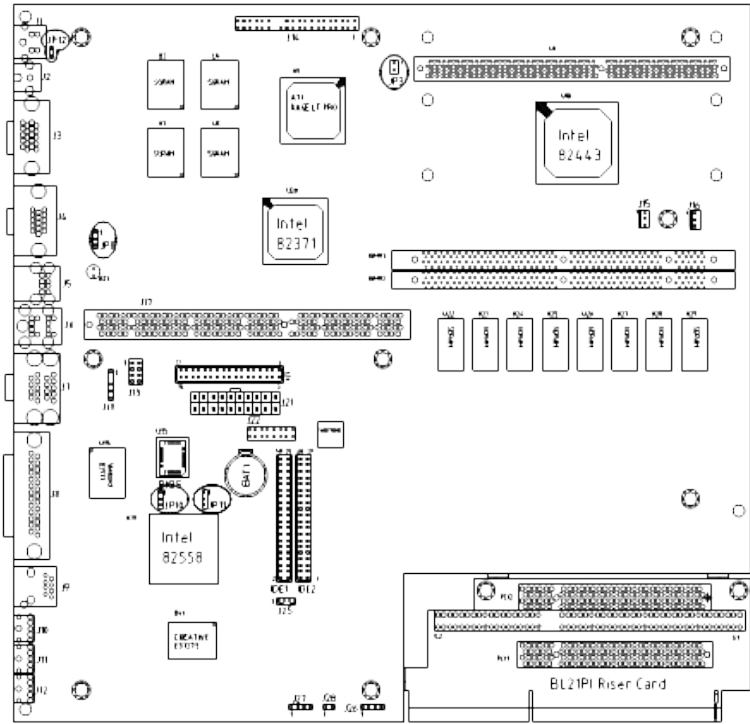

Figure 2: Jumper Location on the LI6BM

4.1 CPU Frequency Selection

Setting CPU Speed in the BIOS Setup



The LI6BM motherboard allows users to set the CPU speed through the BIOS Setup. The parameters used in configuring the CPU speed include *CPU Clock Multiplier* (X3, X3.5, X4, X4.5, X5) and *CPU Clock* (66MHz, 68MHz, 75MHz, 83MHz or 100MHz, 103MHz, 112MHz, 133MHz).

In the initial setup, the system automatically detects the base Frequency of the CPU (66MHz or 100MHz). Under the under *CPU Speed Setting* section, use the ↑ and ↓ keys to easily change the CPU speed or press the PageUp or PageDown key to see more options.

Overclocking could cause the system not to boot in the process of setting the CPU speed. When this happens, turn off the computer by pressing the power button and turn it on again by pressing the **Insert** key and the power button simultaneously. When the system is turned on, press the **Delete** key to enter BIOS Setup and configure the CPU speed.

4.2 Keyboard Power On Function: JP8, J10

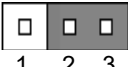
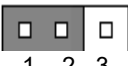
The keyboard can be used as a switch to power on the system. Use JP8 and JP10 to configure this function as shown in the table below.

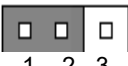
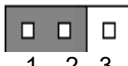
JP8	JP10	Keyboard Power On Function
 1 2 3	1-2 short or 2-3 short	Disabled
 1 2 3	 1 2 3	Power on by any method (power button, keyboard password or a hot key)
 1 2 3	 1 2 3	Power on by keyboard password or hot key as set in the BIOS. When password or hot key is configured, power button can only turn off but not turn on the system. When password or hot key is not configured, power button can be used to turn on the system.

The **keyboard power on** can be configured in the Power On Function field of the Integrated Peripherals section in the BIOS. See page 59 for more details.

4.3 Clear CMOS Select: JP11

Use JP11, to clear the contents of the CMOS RAM. Do not clear the CMOS RAM unless it is absolutely necessary. Before clearing CMOS, you should disconnect the ATX-power connector from the motherboard.

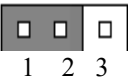
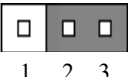
JP11	Jumper Setting	Function
 <p>1 2 3</p>	pin 1-2: short	Normal
 <p>1 2 3</p>	pin 2-3: short	Clear CMOS



4.4 TV-Out Hardware Compliance Setting: JP12

The 2-pin JP12 jumper for TV-Out hardware compliance setting is *relevant only to the S-Video connector and not to the RCA connector*. Although S-Video provides better TV output quality, specifications of TV sets in the market are not consistent. The LI6BM motherboard comes with the ATI RAGE LT PRO VGA controller that auto detects TV signals. It is able to determine if there is a TV set connected to the computer or not.

When the S-Video connector is used to connect the computer to the TV set, your computer monitor and the TV set will show images after you have turned them on. However, if your computer is functioning properly but the TV screen is blank, then you have to *short/close* the JP12 jumper located just at the back of the S-Video connector on the LI6BM. After doing so, restart your computer. *The default setting of JP12 is OPEN.*

4.5 CPU Host Frequency Force Selector: JP3

The LI6BM is able to detect the host frequency (66MHz or 100MHz) of the installed CPU. The JP3 jumper, however, can be set to **OPEN** to override the detection and force the host frequency to run at 100MHz.

JP3	Function	JP3	Function
 <p>SHORT</p>	Host Frequency Auto-detect (default)	 <p>OPEN</p>	Host Frequency set to 100MHz

Chapter 5 Installation

This chapter describes the interface that the LI6BM provides for creating a working system. Refer to Figure 3 for the location of the connectors.

The following items are covered in this chapter:

5.1 I/O Connectors.....	24
5.2 J1: S-VHS Connector.....	24
5.3 J2: RCA Connector.....	24
5.4 J3: Panel Link Connector (option).....	25
5.5 J4: CRT Connector.....	25
5.6 J5: USB Connector.....	26
5.7 J6: PS/2 Keyboard and PS/2 Mouse Connectors.....	26
5.8 J7: Serial Ports.....	27
5.9 J8: Parallel Port Connector.....	27
5.10 J9: RJ45 Connector (option).....	28
5.11 J10, J11, J12: Line Out, Line In, Mic Connectors.....	28
5.12 J22: Game Port Connector.....	28
5.13 J14: AMC Connector.....	29
5.14 J15: CPU Fan Power Connector.....	29
5.15 J16: Chassis Fan Power Connector.....	30
5.16 J17: BL21PI Riser Card Connector.....	30
5.17 J18: IrDA Connector.....	30
5.18 J19: Front Bezel Connectors.....	30
5.19 J20: Floppy Drive Connector.....	31
5.20 J21: ATX Power Supply Connector.....	31
5.21 J23, J24: IDE1 and IDE2 Connectors.....	32
5.22 J25, J26: CD-ROM Audio In Connectors.....	33
5.23 J27: Auxiliary Audio In Connector.....	33

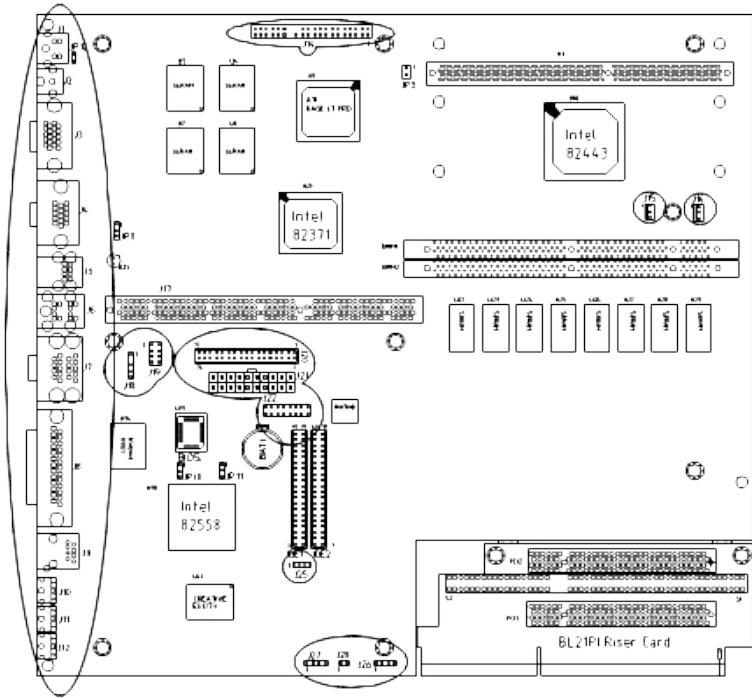

Figure 3: Connector Location on the LI6BM

5.1 I/O Connectors

The I/O connectors connect the LI6BM to the most common peripherals. To attach cables to these connectors, carefully align Pin 1 of the cables to that of the connectors. Refer to Figure 4 for the location and orientation of the connectors.

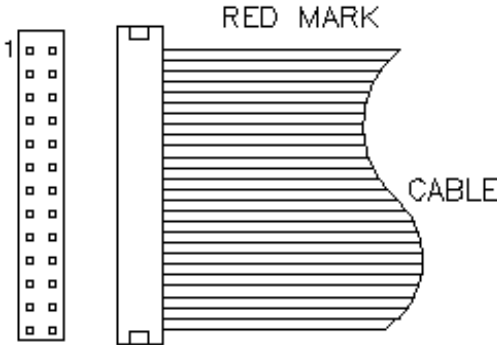
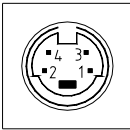

Figure 4: Orientation of the I/O Connector

5.2 J1: S-VHS Connector

The J1 S-VHS connector is for the TV-Out feature of the onboard *ATI 3D RAGE LT PRO* VGA controller. Below are the pin-out assignments of the connectors.



Pin #	Signal Name
1	Ground
2	Ground
3	Luminance Signal
4	Composite Signal

5.3 J2: RCA Connector

The J2 RCA connector is for the TV-Out feature of the onboard *ATI 3D RAGE LT PRO* VGA controller.



5.4 J3: Panel Link Connector (option)

Below are the pin-out assignments of the connectors.

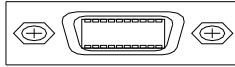

Signal Name	Pin #	Pin #	Signal Name
TXOUT 1+	1	11	TXOUT 2+
TXOUT 1-	2	12	TXOUT 2-
Ground	3	13	Ground
Ground	4	14	Ground
TXCLKOUT+	5	15	TXOUT 0+
TXCLKOUT-	6	16	TXOUT 0-
Ground	7	17	No Connect
Vcc	8	18	No Connect
No Connect	9	19	GPI013
No Connect	10	20	GPI012s

5.5 J4: CRT Connector

J4 is a DB-15 VGA connector. The following table shows the pin-out assignments of this connector.

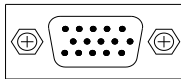

Signal Name	Pin #	Pin #	Signal Name
Red	1	2	Green
Blue	3	4	N.C.
Ground	5	6	Ground
Ground	7	8	Ground
N.C.	9	10	Ground
N.C.	11	12	N.C.
HSYNC	13	14	VSYNC
NC	15		

5.6 J5: USB Connector

J5 is the standard USB external connector consisting of two ports. USB support allows connections of up to 64 plug and play external peripherals per channel. The following table shows the pin outs of these ports.

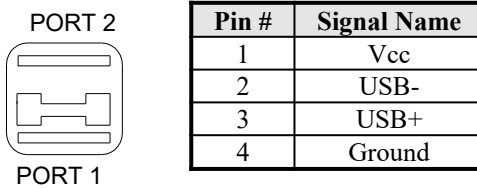

5.7 J6: PS/2 Keyboard and PS/2 Mouse Connectors

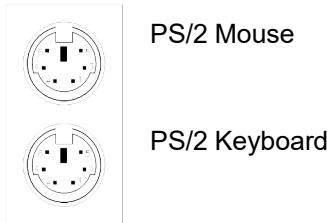

Below are the pin-out assignments of the connectors.

Signal Name	Keyboard	Mouse	Signal Name
Keyboard data	1	1	Mouse data
No Connect	2	2	No Connect
Ground	3	3	No Connect
5V	4	4	5V
Keyboard clock	5	5	Mouse Clock
No Connect	6	6	No Connect

5.8 J7: Serial Ports

The onboard serial ports of the LI6BM are two DB-9 external connectors.

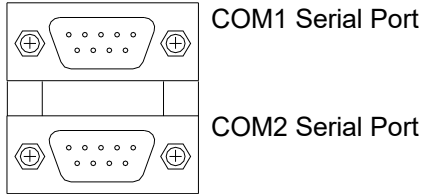

The table below shows the pin-out assignments of these connectors.

Signal Name	Pin #	Pin #	Signal Name
DCD, Data carrier detect	1	6	DSR, Data set ready
RXD, Receive data	2	7	RTS, Request to send
TXD, Transmit data	3	8	CTS, Clear to send
DTR, Data terminal ready	4	9	RI, Ring indicator
GND, ground	5	10	Not Used

5.9 J8: Parallel Port Connector

J8 is a DB-25 external connector as seen in the above figure. The following table describes the pin-out assignments of this connector.

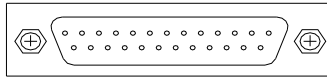

Signal Name	Pin #	Pin #	Signal Name
Line printer strobe	1	14	AutoFeed
PD0, parallel data 0	2	15	Error
PD1, parallel data 1	3	16	Initialize
PD2, parallel data 2	4	17	Select
PD3, parallel data 3	5	18	Ground
PD4, parallel data 4	6	19	Ground
PD5, parallel data 5	7	20	Ground
PD6, parallel data 6	8	21	Ground
PD7, parallel data 7	9	22	Ground
ACK, acknowledge	10	23	Ground
Busy	11	24	Ground
Paper empty	12	25	Ground
Select	13	N/A	N/A

5.10 J9: RJ45 Connector (option)

This connector is for the 10/100Mbps Ethernet capability of the CPU card. The figure below shows the pin out assignments of this connector and its corresponding input jack.

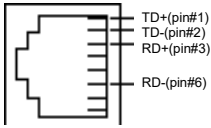

5.11 J10, J11, J12: Line Out, Line In, Mic Connectors

The Line Out (J10), Line In (J11) and Mic (J12) connectors, as shown in the figure below, are used in conjunction with the audio function of the onboard audio controller.

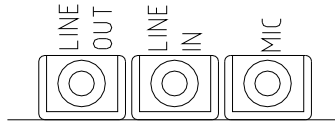

5.12 J22: Game Port Connector

J22 is a 16-pin header connector for the game port cable that comes with the motherboard. It is part of the functions provided by the onboard audio controller.

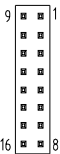

Signal Name	Pin #	Pin #	Signal Name
Vcc	1	9	Vcc
JOY4	2	10	JOY6
JOYTIME0	3	11	JOYTIME2
Ground	4	12	MIDI OUT
Ground	5	13	JOYTIME3
JOYTIME1	6	14	JOY7
JOY5	7	15	MIDI IN
Vcc	8	16	No Connect

5.13 J14: AMC Connector

The AMC (ATI Multimedia Channel) connector facilitates the use of ATI products for multimedia applications and supports DVS for video input into the graphics controller, MPP for video input and output from the graphics controller and I2C for controlling attached devices.

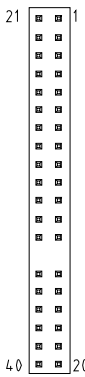

Signal Name	Pin #	Pin #	Signal Name
ZVPORT0	1	2	Ground
ZVPORT1	3	4	Ground
ZVPORT2	5	6	Ground
ZVPORT3	7	8	GPIO8
ZVPORT4	9	10	GPIO9
ZVPORT5	11	12	GPIO10
ZVPORT6	13	14	GPIO11
ZVPORT7	15	16	GPIO12
ZVPORT18	17	18	Ground
GPIO0	19	20	Ground
GPIO1	21	22	Ground
GPIO2	23	24	GPIO13
Ground	25	26	No Connect
No Connect	27	28	No Connect
GPIO3	29	30	+5V
GPIO7	31	32	Reset
GPIO5	33	34	GPIO6
REV	35	36	GPIO4
+12V	37	38	Ground
No Connect	39	40	No Connect

5.14 J15: CPU Fan Power Connector

J15 is a 3-pin header for the CPU fan power connector. The fan must be a 12V fan.

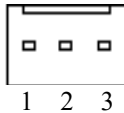

Pin #	Signal Name
1	Rotation
2	+12V
3	Ground

5.15 J16: Chassis Fan Power Connector

J16 is a 3-pin header for the chassis fan power connector. The fan must be a 12V fan.

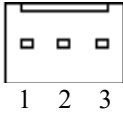

Pin #	Signal Name
1	Rotation
2	+12V
3	Ground

5.16 J17: BL21PI Riser Card Connector

J17 is a slot connector for the BL21PI riser card that comes with the LI6BM motherboard. The riser card comes with two PCI and one ISA slots.

5.17 J18: IrDA Connector

This connector is used for an IrDA connector that supports infrared wireless communication.

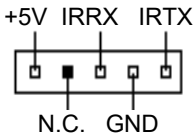

Pin #	Signal Name
1	+5V
2	No connect
3	Ir RX
4	Ground
5	Ir TX

5.18 J19: Front Bezel Connectors

The front bezel of the case has a control panel that provides light indication of the computer activities and switches to change the computer status. J19 is an 8-pin header that provides the interfaces.

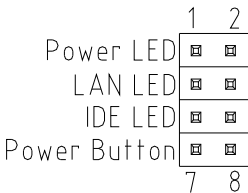

Pin #	Signal Name
1	+5V
2	Ground
3	5VSB
4	LAN Active LED
5	+5V
6	IDE LED
7	Ground
8	Power Button

5.19 J20: Floppy Drive Connector

J20 of the LI6BM is a 34-pin header and will support up to 2.88MB floppy drives. The following table shows its pin-out assignments.

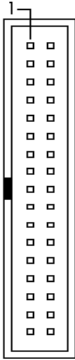

Signal Name	Pin #	Pin #	Signal Name
Ground	1	2	RM/LC
Ground	3	4	No connect
Ground	5	6	No connect
Ground	7	8	Index
Ground	9	10	Motor enable 0
Ground	11	12	Drive select 1
Ground	13	14	Drive select 0
Ground	15	16	Motor enable 1
Ground	17	18	Direction
Ground	19	20	Step
Ground	21	22	Write data
Ground	23	24	Write gate
Ground	25	26	Track 00
Ground	27	28	Write protect
Ground	29	30	Read data
Ground	31	32	Side 1 select
Ground	33	34	Diskette change

5.20 J21: ATX Power Supply Connector

J21 should be used with an ATX power supply with 3.3V specification. Refer to the table below for the pin out assignments.

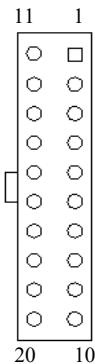

Signal Name	Pin #	Pin #	Signal Name
3.3V	11	1	3.3V
-12V	12	2	3.3V
Ground	13	3	Ground
PS-ON	14	4	+5V
Ground	15	5	Ground
Ground	16	6	+5V
Ground	17	7	Ground
-5V	18	8	Power good
+5V	19	9	5VSB
+5V	20	10	+12V

5.21 J23, J24: IDE1 and IDE2 Connectors

J23: Primary IDE Connector

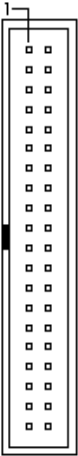

Signal Name	Pin #	Pin #	Signal Name
Reset IDE	1	2	Ground
Host data 7	3	4	Host data 8
Host data 6	5	6	Host data 9
Host data 5	7	8	Host data 10
Host data 4	9	10	Host data 11
Host data 3	11	12	Host data 12
Host data 2	13	14	Host data 13
Host data 1	15	16	Host data 14
Host data 0	17	18	Host data 15
Ground	19	20	Key
DRQ0	21	22	Ground
Host IOW	23	24	Ground
Host IOR	25	26	Ground
IOCHRDY	27	28	Host ALE
DACK0	29	30	Ground
IRQ14	31	32	No connect
Address 1	33	34	No connect
Address 0	35	36	Address 2
Chip select 0	37	38	Chip select 1
Activity	39	40	Ground

J24: Secondary IDE Connector

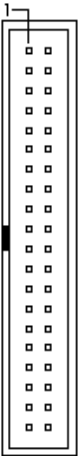

Signal Name	Pin #	Pin #	Signal Name
Reset IDE	1	2	Ground
Host data 7	3	4	Host data 8
Host data 6	5	6	Host data 9
Host data 5	7	8	Host data 10
Host data 4	9	10	Host data 11
Host data 3	11	12	Host data 12
Host data 2	13	14	Host data 13
Host data 1	15	16	Host data 14
Host data 0	17	18	Host data 15
Ground	19	20	Key
DRQ0	21	22	Ground
Host IOW	23	24	Ground
Host IOR	25	26	Ground
IOCHRDY	27	28	Host ALE
DACK1	29	30	Ground
MIRQ0	31	32	No connect
Address 1	33	34	No connect
Address 0	35	36	Address 2
Chip select 0	37	38	Chip select 1
Activity	39	40	Ground

5.22 J25, J26: CD-ROM Audio In Connectors

J25 and J26 are the onboard CD-ROM audio in connectors. Below are their pin assignments.

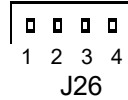
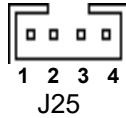

Signal Name	Pin #	Pin #	Signal Name
Ground	1	1	Left
Left	2	2	Ground
Ground	3	3	Ground
Right	4	4	Right

5.23 J27: Auxiliary Audio In Connector

J27 is the auxiliary audio-in connector. The table below shows the pin assignments of this connector.

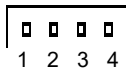

Pin #	Signal Name
1	Left
2	Ground
3	Ground
4	Right

Chapter 6 BIOS and System Setup

This chapter describes the different settings available in the Award BIOS. The topics covered in this chapter are as follows:

6.1 BIOS Introduction.....	37
6.2 BIOS Setup.....	37
6.3 Standard CMOS Setup.....	39
Date.....	39
Time.....	40
Primary HDDs / Secondary HDDs.....	40
Drive A / Drive B.....	41
Video.....	41
Halt On.....	41
6.4 BIOS Features Setup.....	42
Virus Warning.....	43
CPU Internal Cache / External Cache.....	43
CPU L2 Cache ECC Checking.....	43
Quick Power On Self Test.....	43
Boot Sequence.....	43
Swap Floppy Drive.....	43
Boot Up Floppy Seek.....	44
Boot Up NumLock Status.....	44
Boot Up System Speed.....	44
IDE HDD Block Mode.....	44
Gate A20 Option.....	44
Typematic Rate Setting.....	44
Typematic Rate (Chars/Sec).....	44
Typematic Delay (Msec).....	44
Security Option.....	44
PCI/VGA Palette Snoop.....	45
OS Select for DRAM > 64MB.....	45
HDD S.M.A.R.T. Capability.....	45
Report No FDD For WIN 95.....	45
Video BIOS Shadow.....	45
C8000 - CBFFF Shadow/DC000 - DFFFF Shadow.....	45
6.5 Chipset Features Setup.....	46
SDRAM RAS-to-CAS Delay.....	46
SDRAM RAS Precharge Time.....	47
SDRAM CAS Latency Time.....	47

Bank DRAM Timing.....	47
SDRAM Cycle Length.....	47
DRAM Clock Select.....	47
DRAM Data Integrity Mode.....	47
Read Around Write.....	47
Concurrent PCI/Host.....	47
System BIOS Cacheable.....	47
Video BIOS Cacheable.....	47
Video RAM Cacheable.....	48
8 Bit I/O Recovery Time.....	48
16 Bit I/O Recovery Time.....	48
Memory Hole at 15MB - 16MB.....	48
Passive Release.....	48
Delayed Transaction.....	48
AGP Aperture Size (MB).....	48
Auto Detect DIMM/PCI Clk.....	48
Spread Spectrum.....	49
OnChip USB.....	49
USB Keyboard Support.....	49
6.6 Power Management Setup.....	49
ACPI Function.....	50
Power Management.....	50
PM Control by APM.....	50
Video Off Method.....	51
Video Off After.....	51
Modem Use IRQ.....	51
Doze Mode.....	51
Standby Mode.....	51
Suspend Mode.....	51
HDD Power Down.....	51
Throttle Duty Cycle.....	51
PCI/VGA Active Monitor.....	51
Soft-Off by PWR-BTTN.....	52
PWR-ON by Modem/LAN.....	52
Resume by Alarm.....	52
IRQ 8 Break Suspend.....	52
Reload Global Timer Events.....	52
6.7 PNP/PCI Configuration.....	53
PNP OS Installed.....	54
Resources Controlled by.....	54
Reset Configuration Data.....	54

IRQ3/4/5/7/9/10/11/12/14/15, DMA0/1/3/5/6/7 assigned to	..54
CPU to PCI Write Buffer.....	54
PCI Dynamic Bursting.....	54
PCI Master 0 WS Write.....	54
PCI Delay Transaction.....	54
PCI#2 Access #1 Retry.....	54
AGP Master 1 WS Write.....	55
AGP Master 1 WS Read.....	55
PCI IRQ Activated by.....	55
Assign IRQ for USB/VGA.....	55
6.8 Load BIOS Defaults.....	56
6.9 Load Setup Defaults.....	56
6.10 CPU Speed Setting / CPU Features Setup.....	57
CPU Speed, CPU Clock Multiplier, CPU/PCI Clock Select...	58
CPU Warning Temperature.....	58
Current System/ CPU/Chips / VGA Temperatures.....	58
Current CPU Fan Speed/Chassis Fan Speed.....	59
VCCP / VTT / VCC3.....	59
Shutdown Temperature.....	59
CPU/Chassis Fan Monitor.....	59
6.11 Integrated Peripherals.....	60
IDE HDD Block Mode.....	61
IDE Primary/Secondary Master/Slave PIO.....	61
IDE Primary/Secondary Master/Slave UDMA.....	61
On-Chip Primary/Secondary PCI IDE.....	61
OnChip IDE Channel0/1.....	61
USB Keyboard Support.....	61
Init AGP Display First.....	61
Power On Function.....	62
Onboard FDC Controller.....	62
Onboard Serial/Parallel Port.....	62
UART Mode Select.....	62
Parallel Port Mode.....	62
6.12 Supervisor / User Password.....	63
6.13 IDE HDD Auto Detection.....	64
6.14 Save & Exit Setup.....	65
6.15 Exit Without Saving.....	65

6.1 BIOS Introduction

The Award BIOS (Basic Input/Output System) installed in your computer system's ROM supports Intel Pentium II processors. The BIOS provides critical low-level support for standard devices such as disk drives, serial and parallel ports. It also adds virus and password protection as well as special support for detailed fine-tuning of the chipset controlling the entire system.

6.2 BIOS Setup

The Award BIOS provides a Setup utility program for specifying the system configurations and settings. The BIOS ROM of the system stores the Setup utility. When you turn on the computer, the Award BIOS is immediately activated. Pressing the key immediately allows you to enter the Setup utility. If you are a little bit late pressing the key, POST (Power On Self Test) will continue with its test routines, thus preventing you from invoking the Setup. If you still wish to enter Setup, restart the system by pressing the "Reset" button or simultaneously pressing the <Ctrl>, <Alt> and <Delete> keys. You can also restart by turning the system Off and back On again. The following message will appear on the screen:

```
Press <DEL> to Enter Setup
```

In general, you press the arrow keys to highlight items, <Enter> to select, the <PgUp> and <PgDn> keys to change entries, <F1> for help and <Esc> to quit.

When you enter the Setup utility, the Main Menu screen will appear on the screen. The Main Menu allows you to select from various setup functions and exit choices.

ROM PCI/ISA BIOS
CMOS SETUP UTILITY
AWARD SOFTWARE, INC.

STANDARD CMOS SETUP	CPU SPEED SETTING
BIOS FEATURES SETUP	INTEGRATED PERIPHERALS
CHIPSET FEATURES SETUP	SUPERVISOR PASSWORD
POWER MANAGEMENT SETUP	USER PASSWORD
PNP/PCI CONFIGURATION	IDE HDD AUTO DETECTION
LOAD BIOS DEFAULTS	SAVE & EXIT SETUP
LOAD SETUP DEFAULTS	EXIT WITHOUT SAVING
ESC : Quit	↑ ↓ → ← : Select Item
F10 : Save & Exit Setup	(Shift) F2 : Change Color
Time, Date, Hard Disk Type	

The section below the setup items of the Main Menu displays the control keys for this menu. Another section at the bottom of the Main Menu just below the control keys section displays information on the currently highlighted item in the list.

NOTE: *After making and saving system changes with Setup, you find that your computer cannot boot, the Award BIOS supports an override to the CMOS settings that resets your system to its default.*

We strongly recommend that you avoid making any changes to the chipset defaults. These defaults have been carefully chosen by both Award and your system manufacturer to provide the absolute maximum performance and reliability.

6.3 Standard CMOS Setup

“Standard CMOS Setup” choice allows you to record some basic hardware configurations in your computer system and set the system clock and error handling. If the motherboard is already installed in a working system, you will not need to select this option. You will need to run the Standard CMOS option, however, if you change your system hardware configurations, the onboard battery fails, or the configuration stored in the CMOS memory was lost or damaged.

ROM PCI/ISA BIOS STANDARD CMOS SETUP AWARD SOFTWARE, INC.									
Date (mm:dd:yy) : Wed, Mar 4 1998									
Time (hh:mm:ss) : 00 : 00 : 00									
HARD DISKS	TYPE	SIZE	CYLS	HEAD	PRECOMP	LANDZ	SECTOR	MODE	
Primary Master	Auto	0	0	0	0	0	0	Auto	
Primary Slave	Auto	0	0	0	0	0	0	Auto	
Secondary Master	Auto	0	0	0	0	0	0	Auto	
Secondary Slave	Auto	0	0	0	0	0	0	Auto	
Drive A	: 1.44M, 3.5in				Base Memory :			640K	
Drive B	: None				Extended Memory :			15360K	
Video	: EGA / VGA				Other Memory :			384K	
Halt On	: All Errors				Total Memory :			16384K	
ESC : Quit			↑ ↓ → ← : Select			Item			PU / PD / + / - : Modify
F1 : Help			(Shift) F2 : Change Color						

At the bottom of the menu are the control keys for use on this menu. If you need any help in each item field, you can press the <F1> key. It will display the relevant information to help you. The memory display at the lower right-hand side of the menu is read-only. It will adjust automatically according to the memory changed. The following describes each item of this menu.

Date

The date format is:

Day : Sun to Sat
Month : 1 to 12
Date : 1 to 31
Year : 1994 to 2079

To set the date, highlight the “Date” field and use the PageUp/ PageDown or +/- keys to set the current time.

Time

The time format is: **Hour** : 00 to 23
 Minute : 00 to 59
 Second : 00 to 59

To set the time, highlight the “Time” field and use the <PgUp>/<PgDn> or +/- keys to set the current time.

Primary HDDs / Secondary HDDs

The onboard PCI IDE connectors provide Primary and Secondary channels for connecting up to four IDE hard disks or other IDE devices. Each channel can support up to two hard disks; the first is the “Master” and the second is the “Slave”.

To enter the specifications for a hard disk drive, you must select first a “Type”. There are 45 predefined types and 4 user definable types are for Enhanced IDE BIOS. Type 1 to 45 are predefined. Type “User” is user-definable. For the Primary Master/Slave as well as Secondary Master/Slave, you can select “Auto” under the TYPE and MODE fields. This will enable auto detection of your IDE drives and CD-ROM drive during POST.

Press <PgUp>/<PgDn> to select a numbered hard disk type or type the number and press the <Enter> key. The hard disk will not work properly if you enter incorrect information for this field. If your hard disk drive type is not matched or listed, you can use Type User to define your own drive type manually. If you select Type User, related information is asked to be entered to the following items.

CYLS : Number of cylinders
HEAD : Number of read/write heads
PRECOMP : Write precompensation
LANDZ : Landing zone
SECTOR : Number of sectors
SIZE : Automatically adjust according to the configuration
MODE (for IDE HDD only) : Auto
 Normal (HD < 528MB)
 Large (for MS-DOS only)
 LBA (HD > 528MB and
 supports Logical Block
 Addressing)

NOTE: The specifications of your drive must match with the drive table. The hard disk will not work properly if you enter incorrect information in these fields. If your hard disk drive type is not matched or listed, you can use Type User to define your own drive type manually.

Drive A / Drive B

These fields identify the types of floppy disk drive A or drive B that has been installed in the computer. The available specifications are:

360KB	1.	2MB	720KB	1.	44M	2.	88M
5.25 in.		5.25 in.	3.5 in.		B		B
					3.5 in.		3.5 in.

Video

This field selects the type of video display card installed in your system. You can choose the following video display cards:

EGA/VGA	For EGA, VGA, SEGA, SVGA or PGA monitor adapters. (default)
CGA 40	Power up in 40 column mode.
CGA 80	Power up in 80 column mode.
MONO	For Hercules or MDA adapters.

Halt On

This field determines whether or not the system will halt if an error is detected during power up.

No errors	The system boot will not be halted for any error that may be detected.
All errors	Whenever the BIOS detects a non-fatal error, the system will stop and you will be prompted.
All, But Keyboard	The system boot will not be halted for a keyboard error; it will stop for all other errors
All, But Diskette	The system boot will not be halted for a disk error; it will stop for all other errors.
All, But Disk/Key	The system boot will not be halted for a keyboard or disk error; it will stop for all others.

6.4 BIOS Features Setup

This section allows you to configure and improve your system and allows you to set up some system features according to your preference.

ROM / PCI ISA BIOS
BIOS FEATURES SETUP
AWARD SOFTWARE, INC.

Virus Warning	: Disabled	Video BIOS Shadow	: Enabled
CPU Internal Cache	: Enabled	C8000-CBFFF Shadow	: Disabled
External Cache	: Enabled	CC000-CFFFF Shadow	: Disabled
CPU L2 Cache ECC Checking	: Enabled	D0000-D3FFF Shadow	: Disabled
Quick Power On Self Test	: Enabled	D4000-D7FFF Shadow	: Disabled
Boot Sequence	: A, C, SCSI	D8000-DBFFF Shadow	: Disabled
Swap Floppy Drive	: Disabled	DC000-DFFF Shadow	: Disabled
Boot Up Floppy Seek	: Enabled		
Boot Up Numlock Status	: On		
Gate A20 Option	: Fast		
Typematic Rate Setting	: Disabled		
Typematic Rate (chars/Sec)	: 6		
Typematic Delay (Msec)	: 250		
Security Option	: Setup		
PCI /VGA Palette Snoop	: Disabled		
OS Select For DRAM>64MB	: Non-OS2	ESC : Quit	↑ ↓ → ← : Select Item
HDD S.M.A.R.T. Capability	: Enabled	F1 : Help	PU/PD/+/- : Modify
Report No FDD For WIN 95	: No	F5 : Old Values	(Shift) F2 : Color
		F6 : Load BIOS Defaults	
		F7 : Load Setup Defaults	

For Intel 82440BX chipset

ROM / PCI ISA BIOS
BIOS FEATURES SETUP
AWARD SOFTWARE, INC.

Virus Warning	: Disabled	Video BIOS Shadow	: Enabled
CPU Internal Cache	: Enabled	C8000-CBFFF Shadow	: Disabled
External Cache	: Enabled	CC000-CFFFF Shadow	: Disabled
CPU L2 Cache ECC Checking	: Enabled	D0000-D3FFF Shadow	: Disabled
Quick Power On Self Test	: Enabled	D4000-D7FFF Shadow	: Disabled
Boot Sequence	: A, C, SCSI	D8000-DBFFF Shadow	: Disabled
Swap Floppy Drive	: Disabled	DC000-DFFF Shadow	: Disabled
Boot Up Floppy Seek	: Enabled		
Boot Up Numlock Status	: On		
IDE HDD Block Mode	: Enabled		
Gate A20 Option	: Fast		
Typematic Rate Setting	: Disabled		
Typematic Rate (chars/Sec)	: 6		
Typematic Delay (Msec)	: 250		
Security Option	: Setup		
PCI /VGA Palette Snoop	: Disabled	ESC : Quit	↑ ↓ → ← : Select Item
OS Select For DRAM>64MB	: Non-OS2	F1 : Help	PU/PD/+/- : Modify
HDD S.M.A.R.T. Capability	: Enabled	F5 : Old Values	(Shift) F2 : Color
		F6 : Load BIOS Defaults	
		F7 : Load Setup Defaults	

For VIA Apollo Pro Plus (82C693) chipset

Virus Warning

This item protects the boot sector and partition table of your hard disk against accidental modifications. If an attempt is made, the BIOS will halt the system and display a warning message. If this occurs, you can either allow the operation to continue or run an anti-virus program to locate and remove the problem.

***NOTE:** Many disk diagnostic programs, which attempt to access the boot sector table, can cause the virus warning. If you will run such a program, disable the Virus Warning feature.*

CPU Internal Cache / External Cache

Cache memory is additional memory that is much faster than conventional DRAM (system memory). CPUs from 486-type on up contain internal cache memory, and most, but not all, modern PCs have additional (external) cache memory. When the CPU requests data, the system transfers the requested data from the main DRAM into cache memory, for even faster access by the CPU. These items allow you to enable (speed up memory access) or disable the cache function. By default, these items are *Enabled*.

CPU L2 Cache ECC Checking

When enabled, this allows ECC checking of the CPU's L2 cache. By default, this field is *Enabled*.

Quick Power On Self Test

When enabled, this field speeds up the Power On Self Test (POST) after the system is turned on. If it is set to *Enabled*, BIOS will skip some items.

Boot Sequence

This field determines the drive that the system searches first for an operating system. The default value is **A, C, SCSI**. The options are :

A, C, SCSI	D, A, SCSI	SCSI, C, A
C, A, SCSI	E, A, SCSI	C only
C, CDROM, A	F, A, SCSI	LS/ZIP, C
CDROM, C, A	SCSI, A, C	

Swap Floppy Drive

This item allows you to determine whether or not to enable Swap Floppy Drive. When enabled, the BIOS swaps floppy drive assignments so that Drive A becomes Drive B, and Drive B becomes Drive A. By default, this field is set to *Disabled*.

Boot Up Floppy Seek

When enabled, the BIOS will seek whether or not the floppy drive installed has 40 or 80 tracks. 360K type has 40 tracks while 760K, 1.2M and 1.44M all have 80 tracks. By default, this field is set to *Enabled*.

Boot Up NumLock Status

This allows you to activate the NumLock function after you power up the system. By default, the system boots up with *NumLock On*.

Boot Up System Speed

This has no function and selects the default system speed (*High*).

IDE HDD Block Mode

This field allows your hard disk controller to use the fast block mode to transfer data to and from your hard disk drive.

Gate A20 Option

This field allows you to select how Gate A20 is worked. Gate A20 is a device used to address memory above 1 MB. The default setting is *Fast*.

Typematic Rate Setting

When disabled, continually holding down a key on your keyboard will generate only one instance. When enabled, you can set the two typematic controls listed next. By default, this field is set to *Disabled*.

Typematic Rate (Chars/Sec)

When the typematic rate is enabled, the system registers repeated keystrokes speeds. Settings are from 6 to 30 characters per second.

Typematic Delay (Msec)

When the typematic rate is enabled, this item allows you to set the time interval for displaying the first and second characters. By default, this item is set to *250msec*.

Security Option

This field allows you to limit access to the System and Setup. The default value is *Setup*. When you select *System*, the system prompts for the User Password every time you boot up. When you select *Setup*, the system always boots up and prompts for the Supervisor Password only when the Setup utility is called up.

PCI/VGA Palette Snoop

Some non-standard VGA display cards may not show colors properly. This field allows you to set whether or not MPEG ISA/VESA VGA Cards can work with PCI/VGA. When this field is enabled, a PCI/VGA can work with an MPEG ISA/VESA VGA card. When this field is disabled, a PCI/VGA cannot work with an MPEG ISA/VESA Card.

OS Select for DRAM > 64MB

This option allows the system to access greater than 64MB of DRAM memory when used with OS/2 that depends on certain BIOS calls to access memory. The default setting is *Non-OS/2*.

HDD S.M.A.R.T. Capability

This option enables and disables the S.M.A.R.T. (Self-Monitoring, Analysis, and Reporting Technology) capability of the hard disks.

Report No FDD For WIN 95

This option allows Windows 95 to share with other peripherals IRQ6, which is assigned to a floppy disk drive if the drive is not existing.

Video BIOS Shadow

This item allows you to change the Video BIOS location from ROM to RAM. Video Shadow will increase the video speed.

C8000 - CBFFF Shadow/DC000 - DFFFF Shadow

Shadowing a ROM reduces the memory available between 640KB to 1024KB. These fields determine whether or not optional ROM will be copied to RAM.

6.5 Chipset Features Setup

This Setup menu controls the configuration of the motherboard chipset.

ROM PCI/ISA BIOS
 CHIPSET FEATURES SETUP
 AWARD SOFTWARE INC.

SDRAM RAS-to-CAS Delay : 3	
SDRAM RAS Precharge Time : 3	
SDRAM CAS Latency Time : 3	
SDRAM Precharge Control : Disabled	
DRAM Integrity Mode : Non-ECC	
System BIOS Cacheable : Disabled	
Video BIOS Cacheable : Enabled	
Video RAM Cacheable : Disabled	
8 Bit I/O Recovery Time : 3	
16 Bit I/O Recovery Time : 2	
Memory Hole At 15MB-16MB : Disabled	
Passive Release : Enabled	
Delayed Transaction : Enabled	
AGP Aperture Size (MB) : 64	
Auto Detect DIMM/PCI Clk : Disabled	ESC : Quit
Spread Spectrum : Disabled	F1 : Help
	F5 : Old Values
	F6 : Load BIOS Defaults
	F7 : Load Setup Defaults
	↑ ↓ → ← : Select Item
	PU/PD/+/- : Modify (Shift) F2 : Color

For Intel 82440BX chipset

ROM PCI/ISA BIOS
 CHIPSET FEATURES SETUP
 AWARD SOFTWARE INC.

Bank 0/1 DRAM Timing : SDRAM 10ns	OnChip USB : Enabled
Bank 2/3 DRAM Timing : SDRAM 10ns	USB Keyboard Support : Disabled
Bank 4/5 DRAM Timing : SDRAM 10ns	
SDRAM Cycle Length : 3	
DRAM CLOCK : Host CLK	
Memory Hole : Disabled	
Read Around Write : Disabled	
Concurrent PCI/Host : Disabled	
Video RAM Cacheable : Disabled	
AGP Aperture Size : 64M	
Auto Detect DIMM/PCI Clk : Disabled	ESC : Quit
Spread Spectrum : Disabled	F1 : Help
	F5 : Old Values
	F6 : Load BIOS Defaults
	F7 : Load Setup Defaults
	↑ ↓ → ← : Select Item
	PU/PD/+/- : Modify (Shift) F2 : Color

For VIA Apollo Pro Plus (82C693) chipset

SDRAM RAS-to-CAS Delay

When DRAM is refreshed, both rows and columns are addressed separately. This field allows you to determine the timing of transition from Row Address Strobe (RAS) to Column Address Strobe (CAS). The default setting is 3.

SDRAM RAS Precharge Time

The precharge time is the number of cycles it takes for the RAS to accumulate its charge before DRAM refresh. If insufficient time is allowed, refresh may be incomplete and the DRAM may fail to retain data. The default setting is **3**.

SDRAM CAS Latency Time

When synchronous DRAM is installed, the number of clock cycles of CAS latency depends on the DRAM timing. The default setting is **3**.

Bank DRAM Timing

These fields define the speed of the DRAM memory onboard. The options are *Normal*, *Medium*, *Fast*, *Turbo*, *SDRAM 8ns* and *SDRAM10ns*. By default, these fields are set to **SDRAM 10ns**.

SDRAM Cycle Length

This field sets the SDRAM cycle length to either 2 or 3. The default setting is **3**.

DRAM Clock Select

The DRAM clock can be set to Host CLK or the CPU clock itself and to *66MHz*. By default, this field is set to **Host CLK**.

DRAM Data Integrity Mode

This field sets the integrity mode of the DRAM memory onboard. The default setting is **Non-ECC**.

Read Around Write

DRAM optimization feature: If a memory read is addressed to a location whose latest write is being held in a buffer before being written to memory, the read is satisfied through the buffer contents, and the read is not sent to the DRAM.

Concurrent PCI/Host

This field enables or disables the concurrent PCI/Host. The default setting is **Disabled**.

System BIOS Cacheable

When enabled, access to the system BIOS ROM addressed at F0000H-FFFFFH is cached, provided that the cache controller is disabled.

Video BIOS Cacheable

When enabled, access to video BIOS addressed at C0000H to C7FFFH is cached, provided that the cache controller is disabled.

Video RAM Cacheable

Selecting *Enabled* allows caching of the video BIOS ROM at C0000h to C7FFFh, resulting in better video performance. However, if any program writes to this memory area, a memory access error may result.

8 Bit I/O Recovery Time

This option specifies the length of the delay (in sysclks) inserted between consecutive 8-bit I/O operations. The settings are 1, 2, 3, 4, 5, 6, 7, or 8. The default setting is 3.

16 Bit I/O Recovery Time

This option specifies the length of the delay (in sysclks) inserted between consecutive 16-bit I/O operations. The settings are 1, 2, 3, 4, 5, 6, 7, or 8. The default setting is 2.

Memory Hole at 15MB - 16MB

In order to improve performance, certain space in memory can be reserved for ISA cards. This field allows you to reserve 15MB to 16MB of memory address space to ISA expansion cards. This makes memory from 15MB and up unavailable to the system. Expansion cards can only access memory up to 16MB. By default, this field is set to *Disabled*.

Passive Release

When enabled, CPU to PCI bus accesses are allowed during passive release. Otherwise, the arbiter only accepts another PCI master access to local DRAM.

Delayed Transaction

The chipset has an embedded 32-bit posted write buffer to support delay transactions cycles. Select *Enabled* to support compliance with PCI specification version 2.1. The default setting is *Enabled*.

AGP Aperture Size (MB)

The field sets aperture size of the graphics. The aperture is a portion of the PCI memory address range dedicated for graphics memory address space. Host cycles that hit the aperture range are forwarded to the AGP without any translation. The options available are 4, 8, 16, 32, 64, 128M and 256. The default setting is *64*.

Auto Detect DIMM/PCI Clk

When enabled, the system automatically shuts off clocks of unused DIMM/PCI slots. The default setting is *Disabled*. This field is for CE testing use only.

Spread Spectrum

This field sets the value of the spread spectrum. Options are Disabled, 1.8% (CNTR), 0.6% (CNTR), 1.8% (DOWN), and 0.6% (DOWN). The default setting is **Disabled**. This field is for CE testing use only.

OnChip USB

The OnChip USB can be enabled to allow support for USB keyboards. See next field.

USB Keyboard Support

When the OnChip USB field is enabled, the USB Keyboard Support field can be either enabled or disabled. The default setting is **Disabled**.

6.6 Power Management Setup

The Power Management Setup allows you to save energy of your system effectively. It will shut down the hard disk and turn off video display after a period of inactivity.

ROM PCI/ISA BIOS
POWER MANAGEMENT SETUP
AWARD SOFTWARE, INC.

ACPI Function	: Disabled	** Reload Global Timer Events **
Power Management	: User Define	IRQ3 (3-7, 9-15), NMI : Disabled
PM Control by APM	: Yes	Primary IDE 0 : Enabled
Video Off Method	: V/H SYNC +Blank	Primary IDE 1 : Enabled
Video Off After	: Standby	Secondary IDE 0 : Disabled
MODEM Use IRQ	: 3	Secondary IDE 1 : Disabled
Doze Mode	: Disabled	Floppy Disk : Disabled
Standby Mode	: Disabled	Serial Port : Enabled
Suspend Mode	: Disabled	Parallel Port : Disabled
HDD Power Down	: Disabled	
Throttle Duty Cycle	: 62.5%	
PCI/VGA Act- Monitor	: Disabled	
Soft-Off by PWR-BTTN	: Instant-Off	
PWR-ON by Modem/LAN	: Disabled	
Resume by Alarm	: Disabled	
IRQ 8 Break Suspend	: Disabled	ESC : Quit ↑ ↓ → ← : Select Item
		F1 : Help PU/PD/+/- : Modify
		F5 : Old Values (Shift) F2 : Color
		F6 : Load BIOS Defaults
		F7 : Load Setup Defaults

For Intel 82440BX chipset

ROM PCI/ISA BIOS
POWER MANAGEMENT SETUP
AWARD SOFTWARE, INC.

ACPI Function	: Enabled	Primary INTR	: ON
Power Management	: User Define	IRQ3 (COM2)	: Primary
PM Control by APM	: Yes	IRQ4 (COM1)	: Primary
Video Off Option	: Suspend	IRQ5 (LPT 2)	: Primary
Video Off Method	: V/H SYNC +Blank	IRQ6 (Floppy Disk)	: Primary
Modem Use IRQ	: 3	IRQ6 (Floppy Disk)	: Primary
Soft-Off by PWRBTN	: Instant-Off	IRQ7 (LPT 1)	: Primary
** PM Timers **		IRQ8 (RTC Alarm)	: Disabled
HDD Power Down	: Disabled	IRQ9 (IRQ2 Redir)	: Secondary
Doze Mode	: Disabled	IRQ10 (Reserved)	: Secondary
Suspend Mode	: Disabled	IRQ11 (Reserved)	: Secondary
** PM Events **		IRQ12 (PS/2 Mouse)	: Primary
VGA	: OFF	IRQ13 (Coproprocessor)	: Primary
LPT & COM	: LPT / COM	IRQ14 (Hard Disk)	: Primary
HDD & FDD	: ON	IRQ15 (Reserved)	: Disabled
DMA / master	: OFF	ESC : Quit	↑ ↓ → ← : Select Item
PWR-On by Modem/LAN	: Disabled	F1 : Help	PU/PD/+/- : Modify
RTC Alarm Resume	: Disabled	F5 : Old Values	(Shift) F2 : Color
		F6 : Load BIOS Defaults	
		F7 : Load Setup Defaults	

For VIA Apollo Pro Plus (82C693) chipset

ACPI Function

This field allows you to enable or disable the ACPI (Advanced Configuration Power Interface) function on the motherboard.

Power Management

This field allows you to select the type of power saving management modes. There are four selections for Power Management.

- Min. Power Saving Minimum power management
- Max. Power Saving Maximum power management.
- User Define Each of the ranges is from 1 min. to 1hr.
Except for HDD Power Down which ranges from 1 min. to 15 min. (Default)

NOTE: In order to enable the CPU overheat protection feature, the Power Management field should not be set to Disabled.

PM Control by APM

This field allows you to use the Advanced Power Management device to enhance the Max. Power Saving mode and stop the CPU's internal clock. If the Max. Power Saving is not enabled, this will be preset to NO.

Video Off Method

This field defines the Video Off features. There are three options.

V/H SYNC + Blank Default setting, blank the screen and turn off vertical and horizontal scanning.

DPMS Allows the BIOS to control the video display card if it supports the DPMS feature.

Blank Screen This option only writes blanks to the video buffer.

Video Off After

As the system moves from lesser to greater power-saving modes, select the mode in which you want the monitor to blank.

Modem Use IRQ

This field names the interrupt request (IRQ) line assigned to the modem (if any) on your system. Activity of the selected IRQ always awakens the system. By default, the IRQ is set to 3.

Doze Mode

When enabled, and after the set time of system inactivity, the CPU clock will run at a slower speed while all other devices still operate at full speed.

Standby Mode

After the selected period of system inactivity, the fixed disk drive and the video shut off while all other devices still operate at full speed.

Suspend Mode

When enabled, and after the set time of system inactivity, all devices except the CPU will be shut off.

HDD Power Down

When enabled, and after the set time of system inactivity, the hard disk drive will be powered down while all other devices remain active.

Throttle Duty Cycle

When the system enters Doze mode, the CPU clock runs only part of the time. You may select the percent of time that the clock runs.

PCI/VGA Active Monitor

When enabled, any video activity restarts the global timer for Standby mode.

Soft-Off by PWR-BTTN

This field defines the power-off mode when using an ATX power supply. The Instant-Off mode allows powering off immediately upon pressing the power button. In the Delay 4 Sec mode, the system powers off when the power button is pressed for more than four seconds or places the system in a very low-power-usage state, with only enough circuitry receiving power to detect power button activity when pressed for less than 4 seconds. The default value is *Instant-Off*.

PWR-ON by Modem/LAN

An input signal on the serial Ring Indicator (RI) line (in other words, an incoming call on the modem or incoming signal from LAN) awakens the system from a soft off state.

Resume by Alarm

This allows a computer to be turned on automatically through the timer set in the BIOS to make the system more scheduleable. By default, this field is set to *Disabled*.

IRQ 8 Break Suspend

You can enable or disable the monitoring of IRQ 8 (Real Time Clock) so it does not awaken the system from Suspend mode.

Reload Global Timer Events

This section determines the reloading of the ‘timers’ after entering the Full On You can enable or disable the monitoring of IRQ 8 (Real Time Clock) so it does not awaken the system from Suspend mode.

6.7 PNP/PCI Configuration

This option configures the PCI bus system. All PCI bus systems on the system use INT#, thus all installed PCI cards must be set to this value.

ROM PCI/ISA BIOS
PNP/PCI CONFIGURATION
AWARD SOFTWARE INC.

PNP OS Installed	: No	Used MEM base addr	: N/A
Resources Controlled by	: Manual		
Reset Configuration Data	: Disabled		
IRQ-3 assigned to	: Legacy ISA		
IRQ-4 assigned to	: Legacy ISA		
IRQ-5 assigned to	: PCI/ISA PnP		
IRQ-7 assigned to	: Legacy ISA		
IRQ-9 assigned to	: PCI/ISA PnP		
IRQ-10 assigned to	: PCI/ISA PnP		
IRQ-11 assigned to	: PCI/ISA PnP		
IRQ-12 assigned to	: PCI/ISA PnP		
IRQ-14 assigned to	: PCI/ISA PnP		
IRQ-15 assigned to	: PCI/ISA PnP		
DMA-0 assigned to	: PCI/ISA PnP		
DMA-1 assigned to	: PCI/ISA PnP		
DMA-3 assigned to	: PCI/ISA PnP		
DMA-5 assigned to	: PCI/ISA PnP		
DMA-6 assigned to	: PCI/ISA PnP		
DMA-7 assigned to	: PCI/ISA PnP		
		ESC : Quit	↑ ↓ ← : Select Item
		F1 : Help	PU/PD/+/- : Modify
		F5 : Old Values	(Shift) F2 : Color
		F6 : Load BIOS Defaults	
		F7 : Load Setup Defaults	

For Intel 82440BX chipset

ROM PCI/ISA BIOS
PNP/PCI CONFIGURATION
AWARD SOFTWARE INC.

PNP OS Installed	: No	CPU to PCI Write Buffer	: Enabled
Resources Controlled by	: Manual	PCI Dynamic Bursting	: Enabled
Reset Configuration Data	: Disabled	PCI Master 0 WS Write	: Enabled
		PCI Delay Transaction	: Enabled
IRQ-3 assigned to	: Legacy ISA	PCI#2 Access #1 Retry	: Disabled
IRQ-4 assigned to	: Legacy ISA	AGP Master 1 WS Write	: Enabled
IRQ-5 assigned to	: PCI/ISA PnP	AGP Master 1 WS Read	: Disabled
IRQ-7 assigned to	: Legacy ISA		
IRQ-9 assigned to	: PCI/ISA PnP	PCI IRQ Activated By	: Level
IRQ-10 assigned to	: PCI/ISA PnP	Assign IRQ For USB	: Enabled
IRQ-11 assigned to	: PCI/ISA PnP	Assign IRQ For VGA	: Enabled
IRQ-12 assigned to	: PCI/ISA PnP		
IRQ-14 assigned to	: PCI/ISA PnP		
IRQ-15 assigned to	: PCI/ISA PnP		
DMA-0 assigned to	: PCI/ISA PnP		
DMA-1 assigned to	: PCI/ISA PnP	ESC : Quit	↑ ↓ ← : Select Item
DMA-3 assigned to	: PCI/ISA PnP	F1 : Help	PU/PD/+/- : Modify
DMA-5 assigned to	: PCI/ISA PnP	F5 : Old Values	(Shift) F2 : Color
DMA-6 assigned to	: PCI/ISA PnP	F6 : Load BIOS Defaults	
DMA-7 assigned to	: PCI/ISA PnP	F7 : Load Setup Defaults	

For VIA Apollo Pro Plus (82C693) chipset

PNP OS Installed

This field allows you to specify if the operating system installed in your system is plug and play aware.

NOTE: Operating systems such as DOS, OS/2, and Windows 3.x do not use PnP

Resources Controlled by

This PnP BIOS can configure all of the boot and compatible devices automatically. However, this capability needs you to use a PnP operating system such as Windows 95. The default value is *Manual*.

Reset Configuration Data

This field allows you to determine whether to reset the configuration data or not. The default value is *Disabled*.

IRQ3/4/5/7/9/10/11/12/14/15, DMA0/1/3/5/6/7 assigned to

These fields allow you to determine the IRQ/DMA assigned to the ISA bus and is not available to any PCI slot.

Used MEM base addr

Select a base address for the memory area used by any peripheral that requires high memory. The default setting is *N/A*.

CPU to PCI Write Buffer

When enabled, this option increases the efficiency of the PCI bus to and speed up the execution in the processor. By default, this field is set to *Enabled*.

PCI Dynamic Bursting

When enabled, this option combines several PCI cycles into one. By default, this field is set to *Disabled*.

PCI Master 0 WS Write

When enabled, this option increases the write cycle speed.

PCI Delay Transaction

When enabled, this option delays PCI data transaction. By default, this field is set to *Enabled*.

PCI#2 Access #1 Retry

This item enables PC#2 Access #1 attempts. By default, this field is set to *Disabled*.

AGP Master 1 WS Write

When enabled, writes to the AGP bus are executed with 1 wait states. By default, this field is set to *Enabled*.

AGP Master 1 WS Read

When enabled, reads to the AGP bus are executed with 1 wait states. By default, this field is set to *Enabled*.

PCI IRQ Activated by

This field allows you to select the method by which the PCI bus recognizes that an IRQ service is being requested by a device. The default value is *Level*.

Assign IRQ for USB/VGA

These fields allow you to enable or disable the IRQ for USB and VGA. By default, these fields are enabled.

6.8 Load BIOS Defaults

This option allows you to load the troubleshooting default values permanently stored in the BIOS ROM. These default settings are non-optimal and disable all high-performance features.

ROM PCI/ISA BIOS
CMOS SETUP UTILITY
AWARD SOFTWARE, INC.

STANDARD CMOS SETUP	CPU SPEED SETTING
BIOS FEATURES SETUP	INTEGRATED PERIPHERALS
CHIPSET FEATURES SETUP	SUPERVISOR PASSWORD
POWER MANAGE	D
PNP/PCI CONF	TECTION
LOAD BIOS DE	UP
LOAD SETUP D	EXIT WITHOUT SAVING
ESC : Quit	↑ ↓ → ← : Select Item
F10 : Save & Exit Setup	(Shift) F2 : Change Color
Load BIOS Defaults except Standard CMOS Setup	

To load BIOS defaults value to CMOS SRAM, enter “Y”. If not, enter “N”.

6.9 Load Setup Defaults

This option allows you to load the default values to your system configuration. These default settings are optimal and enable all high performance features.

ROM PCI/ISA BIOS
CMOS SETUP UTILITY
AWARD SOFTWARE, INC.

STANDARD CMOS SETUP	CPU SPEED SETTING
BIOS FEATURES SETUP	INTEGRATED PERIPHERALS
CHIPSET FEATURES SETUP	SUPERVISOR PASSWORD
POWER MANAGE	D
PNP/PCI CONF	TECTION
LOAD BIOS DE	UP
LOAD SETUP DEF	EXIT WITHOUT SAVING
ESC : Quit	↑ ↓ → ← : Select Item
F10 : Save & Exit Setup	(Shift) F2 : Change Color
Load BIOS Defaults except Standard CMOS Setup	

To load SETUP defaults value to CMOS SRAM, enter “Y”. If not, enter “N”.

6.10 CPU Speed Setting / CPU Features Setup

This Setup menu controls the configuration of the motherboard chipset.

ROM PCI/ISA BIOS
CPU SPEED SETTING
AWARD SOFTWARE INC.

CPU Speed	: Manual		:
CPU Clock Multiplier	: X 3		:
CPU Clock Select	: 66 MHz		:
CPU Warning Temperature	: 66°C/151°F		:
Current System Temp.	: 41°C/ 105°F		:
Current CPU/Chips Temp.	: 27°C/ 80°F		:
Current System VGA Temp.	: 34°C/ 93°F		:
Current CPU Fan Speed	: 2789 RPM		:
Current Chassis Fan Speed	: 2045 RPM		:
VTT (V):	: 1.48 V	VCCP (V)	: 1.98 V
VCC3 (V)	: 3.45 V	+ 5 V	: 4.99 V
+12 V	: 12.46 V	-12 V	: -12.54V
-5V	: - 5.21 V		:
Shutdown Temperature	: 75°C/ 167°F	ESC : Quit	↑ ↓ → ← : Select Item
CPU Fan Monitor	: Disabled	F1 : Help	PU/PD/+/- : Modify
Chassis Fan Monitor	: Disabled	F5 : Old Values	(Shift) F2 : Color
		F6 : Load BIOS Defaults	
		F7 : Load Setup Defaults	

For Intel 82440BX chipset

ROM PCI/ISA BIOS
CPU SPEED SETTING
AWARD SOFTWARE INC.

CPU Speed	: Manual		:
CPU Clock Multiplier	: X 3		:
CPU Clock Select	: 66 MHz		:
CPU Warning Temperature	: 66°C/151°F		:
Current System Temp.	: 41°C/ 105°F		:
Current CPU/Chips Temp.	: 27°C/ 80°F		:
Current System VGA Temp.	: 34°C/ 93°F		:
Current CPU Fan Speed	: 2789 RPM		:
Current Chassis Fan Speed	: 2045 RPM		:
VCCP (V):	: 1.95 V	VTT (V)	: 1.52 V
VCC3 (V)	: 3.28 V	+ 5 V	: 4.97 V
+12 V	: 12.03 V	-12 V	: -11.92V
-5V	: - 5.09 V		:
Shutdown Temperature	: 75°C/ 167°F	ESC : Quit	↑ ↓ → ← : Select Item
CPU Fan Monitor	: Disabled	F1 : Help	PU/PD/+/- : Modify
Chassis Fan Monitor	: Disabled	F5 : Old Values	(Shift) F2 : Color
		F6 : Load BIOS Defaults	
		F7 : Load Setup Defaults	

For VIA Apollo Pro Plus (82C693) chipset

CPU Speed, CPU Clock Multiplier, CPU/PCI Clock Select

The LI6BM motherboard allows users to set the CPU speed through the BIOS. The parameters in setting the CPU speed include *CPU Clock Multiplier* (see examples below) and *CPU Clock* (66MHz, 75MHz, 83MHz or 100MHz, 103MHz, 112MHz, 133MHz, 150MHz).

In the initial setup, the system automatically detects the base Frequency of the CPU (66MHz or 100MHz). Press the ↑ and ↓ keys to change the CPU speed or press the PageUp or PageDown key to see the selections for CPU Clock Multiplier and CPU Clock.

CPU speed configuration examples:

A. CPU-frequency auto-detect

CPU Speed	: 300MHz (100x3)
-----------	------------------

Parameters:
CPU Clock Multiplier = 3/3.5/4/4.5/5/5.5/6
CPU Clock Select = 100MHz (fixed)

CPU Speed	: 233MHz (66x3.5)
-----------	-------------------

Parameters:
CPU Clock Multiplier = 3/3.5/4/4.5/5/5.5/6
CPU Clock Select = 66MHz (fixed)

B. Manual

CPU Speed	Manual
CPU Clock Multiplier	: X 3
CPU/PCI Clock Select	: 100 MHz

Parameters:
CPU Clock Multiplier = 3 ~ 6.5 (BX chipset)
CPU Clock Multiplier = 3 ~ 8 (82C693 chipset)
CPU Clock Select = 100 MHz
103 MHz
112 MHz
133 MHz
150 MHz

CPU Speed	Manual
CPU Clock Multiplier	: X 3.5
CPU/PCI Clock Select	: 66 MHz

Parameters:
CPU Clock Multiplier = 3 ~ 6.5 (BX chipset)
CPU Clock Multiplier = 3 ~ 8 (82C693 chipset)
CPU Clock Select = 66 MHz
75 MHz
83 MHz

NOTE: *Overclocking could cause the system not to boot. When this happens, turn off the computer by pressing the power button and turn it on again by pressing the **Insert** key and the power button simultaneously. Then press the **Delete** key to enter BIOS Setup and configure the CPU speed.*

CPU Warning Temperature

This field sets the threshold value for the CPU warning temperature. An alert is sounded through the system's speaker when the CPU temperature exceeds the set value. The function prevents overheating and damage on the CPU.

Current System/ CPU/Chips / VGA Temperatures

These read-only fields reflect the functions of the hardware thermal sensor that monitors the chip blocks and system temperatures to ensure the system is stable.

Current CPU Fan Speed/Chassis Fan Speed

These read-only fields show the current speeds in RPM (revolution per minute) for the CPU fan and chassis fan as monitored by the hardware monitoring IC.

VCCP / VTT / VCC3

These read-only fields show the current voltages in the voltage regulators and power supply as monitored by the To clear CMOS, the ATX-power connector should be disconnected from the motherboard hardware monitoring IC.

Shutdown Temperature

This field allows you to set the temperature at which the system automatically shuts down once it is reached, in order to avoid damage to system components.

CPU/Chassis Fan Monitor

The CPU Fan Monitor and Chassis Fan Monitor fields allow the user to set the threshold value of the fans' rotation. When the rotation falls below the set value, the systems sounds out an alarm through the speaker. RPM options are *3,000rpm*, *3,500rpm* and *4,000rpm*.

6.11 Integrated Peripherals

This option sets your hard disk configuration, mode and port.

ROM PCI/ISA BIOS
INTEGRATED PERIPHERALS
AWARD SOFTWARE INC.

IDE HDD Block Mode	: Enabled	Onboard FDC Controller	: Enabled
IDE Primary Master PIO	: Auto	Onboard Serial Port 1	: 3F8/IRQ4
IDE Primary Slave PIO	: Auto	Onboard Serial Port 2	: 2F8/IRQ3
IDE Secondary Master PIO	: Auto	UART Mode Select	: Normal
IDE Secondary Slave PIO	: Auto		
IDE Primary Master UDMA	: Auto	Onboard Parallel Port	: 378/IRQ7
IDE Primary Slave UDMA	: Auto	Parallel Port Mode	: SPP
IDE Secondary Master UDMA	: Auto		
On-Chip Primary PCI IDE	: Enabled		
On-Chip Secondary PCI IDE	: Enabled		
USB Keyboard Support	: Disabled		
Init Display First	: AGP		
POWER ON Function	: Button Only		
		ESC : Quit	↑ ↓ ← : Select Item
		F1 : Help	PU/PD/+/- : Modify
		F5 : Old Values	(Shift) F2 : Color
		F6 : Load BIOS Defaults	
		F7 : Load Setup Defaults	

For Intel 82440BX chipset

ROM PCI/ISA BIOS
INTEGRATED PERIPHERALS
AWARD SOFTWARE INC.

On-Chip IDE Channel 0	: Enabled	Onboard FDC Controller	: Enabled
On-Chip IDE Channel 1	: Enabled	Onboard Serial Port 1	: 3F8/IRQ4
IDE Prefetch Mode	: Disabled	Onboard Serial Port 2	: 2F8/IRQ3
IDE HDD Block Mode	: Enabled	UART Mode Select	: Normal
Primary Master PIO	: Auto		
Primary Slave PIO	: Auto	Onboard Parallel Port	: 378/IRQ7
Secondary Master PIO	: Auto	Parallel Port Mode	: SPP
Secondary Slave PIO	: Auto		
Primary Master UDMA	: Auto		
Primary Slave UDMA	: Auto		
Secondary Master UDMA	: Auto		
Secondary Slave UDMA	: Auto		
Init AGP Display First	: AGP		
POWER ON Function	: Button Only		
		ESC : Quit	↑ ↓ ← : Select Item
		F1 : Help	PU/PD/+/- : Modify
		F5 : Old Values	(Shift) F2 : Color
		F6 : Load BIOS Defaults	
		F7 : Load Setup Defaults	

For VIA Apollo Pro Plus (82C693) chipset

IDE HDD Block Mode

This field allows your hard disk controller to use the fast block mode to transfer data to and from your hard disk drive.

IDE Primary/Secondary Master/Slave PIO

These fields allow your system hard disk controller to work faster. Rather than have the BIOS issue a series of commands that transfer to or from the disk drive, PIO (Programmed Input/Output) allows the BIOS to communicate with the controller and CPU directly.

The system supports five modes, numbered from 0 (default) to 4, which primarily differ in timing. When Auto is selected, the BIOS will select the best available mode.

IDE Primary/Secondary Master/Slave UDMA

These fields allow your system to improve disk I/O throughput to 33Mb/sec with the Ultra DMA/33 feature. The options are *Auto* and *Disabled*.

On-Chip Primary/Secondary PCI IDE

The integrated peripheral controller contains an IDE interface with support for two IDE channels. Select *Enabled* to activate each channel separately.

OnChip IDE Channel0/1

The integrated peripheral controller contains an IDE interface with support for two IDE channels. Select *Enabled* to activate each channel separately.

USB Keyboard Support

Select *Enabled* if your system contains a Universal Serial Bus (USB) controller and you have a USB keyboard.

Init AGP Display First

This field allows the system to initialize first the VGA card in the AGP slot on the motherboard when system is turned on.

Power On Function

The default for this field is **BUTTON ONLY**. When set to *KB Power ON Password*, the user is allowed to set a password with a maximum of 5 characters. The system recognizes the size (lowercase/uppercase) of the characters entered. The third option is *Hot Key Power ON*. The keys Ctrl-F1 to Ctrl-F12 can be set to power on the system.

- Notes:
1. After setting the password or hot key, do not turn off the system immediately. The system can be turned off only after the memory test has been finished in order that the keyboard-power -on settings to take effect.
 2. If you forget your password and you cannot turn on the system, you have to clear the CMOS content.
 3. USB keyboards do not support Keyboard Power On Function.
 4. Keyboard Power On Function (password or hot keys) is enabled only when the jumper JP8 is **1-2 short**. Setting it to **2-3 short** disables the Keyboard Power On Function. See page 17.

Onboard FDC Controller

Select *Enabled* if your system has a floppy disk controller (FDC) installed on the system board and you wish to use it. If you install an add-in FDC or the system has no floppy drive, select *Disabled* in this field. This option allows you to select the onboard FDD port.

Onboard Serial/Parallel Port

These fields allow you to select the onboard serial and parallel ports and their addresses. The default values for these ports are:

Serial Port 1	3F8/IRQ4
Serial Port 2	2F8/IRQ3
Parallel Port	378H/IRQ7

UART Mode Select

This field determines the UART mode in your computer. The settings are *Normal*, *IrDA* and *ASKIR*. The default value is *Normal*.

Parallel Port Mode

This field allows you to determine parallel port mode function.

SPP	Normal Printer Port
EPP	Enhanced Parallel Port
ECP	Extended Capabilities Port

6.12 Supervisor / User Password

These two options set the system password. Supervisor Password sets a password that will be used to protect the system and Setup utility. User Password sets a password that will be used exclusively on the system. To specify a password, highlight the type you want and press <Enter>. The Enter Password: message prompts on the screen. Type the password, up to eight characters in length, and press <Enter>. The system confirms your password by asking you to type it again. After setting a password, the screen automatically returns to the main screen.

To disable a password, just press the <Enter> key when you are prompted to enter the password. A message will confirm the password to be disabled. Once the password is disabled, the system will boot and you can enter Setup freely.

ROM PCI/ISA BIOS CMOS SETUP UTILITY AWARD SOFTWARE, INC.	
STANDARD CMOS SETUP BIOS FEATURES SETUP CHIPSET FEATURES SETUP POWER MANAGE PNP/PCI CONF LOAD BIOS DEF LOAD SETUP D	CPU SPEED SETTING INTEGRATED PERIPHERALS SUPERVISOR PASSWORD D ETECTION UP AVING
<div style="border: 1px solid black; padding: 5px; display: inline-block;"> Enter Password: </div>	
ESC : Quit F10 : Save & Exit Setup	↑ ↓ → ← : Select Item (Shift) F2 : Change Color
Change / Set / Disable Password	

6.13 IDE HDD Auto Detection

This option detects the parameters of an IDE hard disk drive, and automatically enters them into the Standard CMOS Setup screen.

ROM PCI/ISA BIOS
STANDARD CMOS SETUP
AWARD SOFTWARE, INC.

HARD DISKS	TYPE	SIZE	CYLS	HEAD	PRECOMP	LANDZ	SECTOR	MODE
Primary Master:								
Select Primary Master Option (N=SKIP) : N								
OPTIONS	TYPE	SIZE	CYLS	HEAD	PRECOMP	LANDZ	SECTOR	MODE
1 (Y)	0	0	0	0	0	0	0	NORMAL
NOTE: Some OSes (like SCO-UNIX) must use "NORMAL" for installation								
ESC: SKIP								

Up to four IDE drives can be detected, with parameters for each appearing in sequence inside a box. To accept the displayed entries, press the “Y” key; to skip to the next drive, press the “N” key. If you accept the values, the parameters will appear listed beside the drive letter on the screen.

6.14 Save & Exit Setup

This option allows you to determine whether or not to accept the modifications. If you type “Y”, you will quit the setup utility and save all changes into the CMOS memory. If you type “N”, you will return to Setup utility.

ROM PCI/ISA BIOS
CMOS SETUP UTILITY
AWARD SOFTWARE, INC.

STANDARD CMOS SETUP	CPU SPEED SETTING
BIOS FEATURES SETUP	INTEGRATED PERIPHERALS
CHIPSET FEATURES SETUP	SUPERVISOR PASSWORD
POWER MANAGE	D
PNP/PCI CONF	TECTION
LOAD BIOS DEF	UP
LOAD SETUP DEFAULTS	EXIT WITHOUT SAVING
ESC : Quit	↑ ↓ → ← : Select Item
F10 : Save & Exit Setup	(Shift) F2 : Change Color
Save Data to CMOS & Exit Setup	

6.15 Exit Without Saving

Select this option to exit the Setup utility without saving the changes you have made in this session. Typing “Y” will quit the Setup utility without saving the modifications. Typing “N” will return you to Setup utility.

ROM PCI/ISA BIOS
CMOS SETUP UTILITY
AWARD SOFTWARE, INC.

STANDARD CMOS SETUP	CPU SPEED SETTING
BIOS FEATURES SETUP	INTEGRATED PERIPHERALS
CHIPSET FEATURES SETUP	SUPERVISOR PASSWORD
POWER MANAGE	D
PNP/PCI CONF	TECTION
LOAD BIOS DEF	UP
LOAD SETUP DEFAULTS	EXIT WITHOUT SAVING
ESC : Quit	↑ ↓ → ← : Select Item
F10 : Save & Exit Setup	(Shift) F2 : Change Color
Abandon all Data & Exit Setup	

Chapter 7 Audio Driver Installation Guide

This chapter describe the audio driver installation procedure for the onboard audio chipset The onboard audio consists of the Creative Labs ES1373 Chip + AC97. With a PCI Bus Mastering interface with DOS compatibility, it supports 32 voices wavetable, surround sound, 3D audio, and audio effects such as reverb and chorus. Creative Labs ES1373 uses single, shareable PCI interrupt and is PC97 compliant.

For normal operations and to maximize the audio functions of the motherboard, follow the audio driver installation procedure below.

Installing The Audio Drivers For Windows 95/98

1. Under Windows 95/98, click **START** => **Setting** => **Control Panel**.

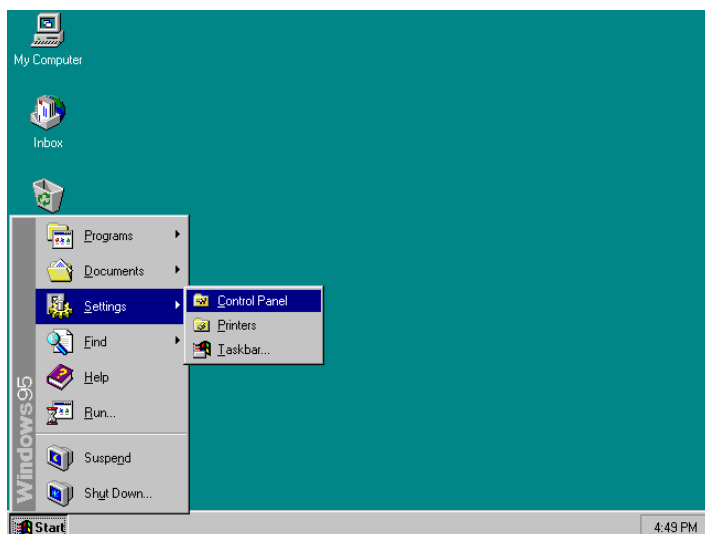

2. Under the Control Panel window, click the System icon.



3. Click Device Manager.

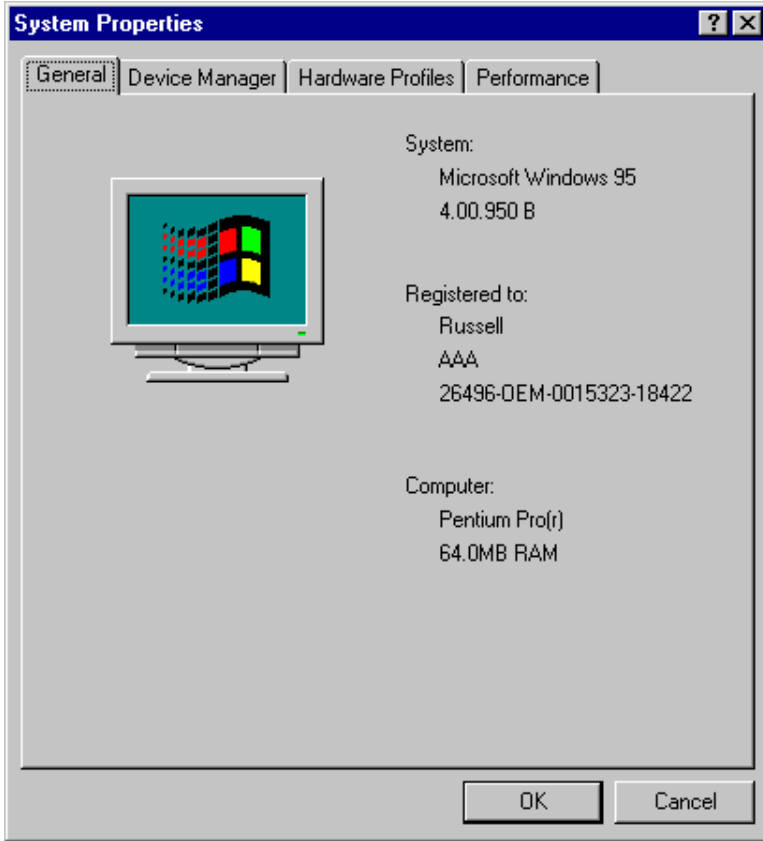

4. Click Other Device, then select PCI Multimedia Audio Device and click the Remove icon.

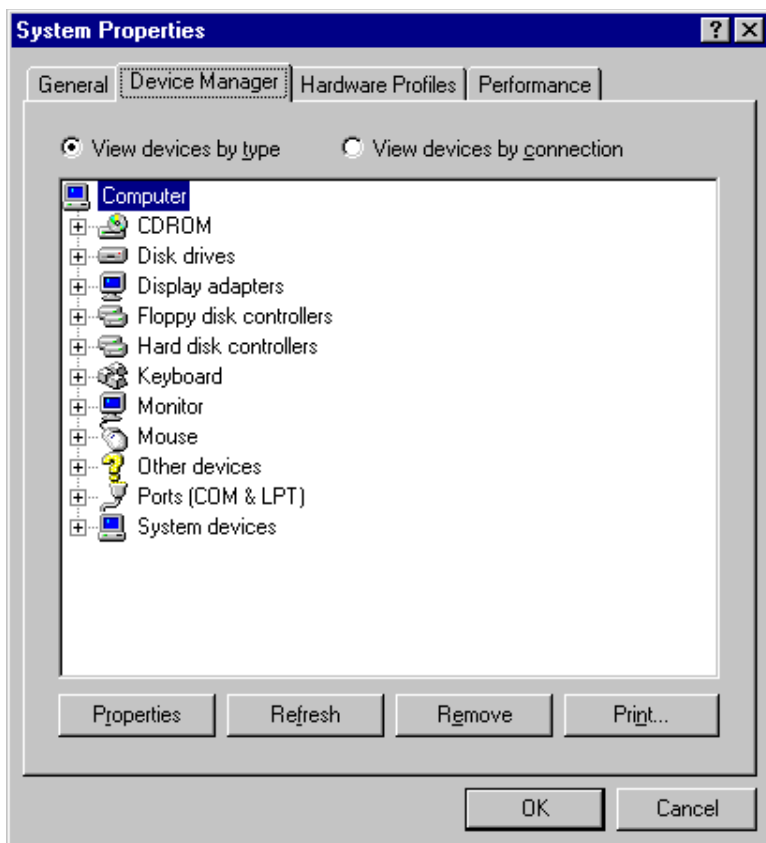

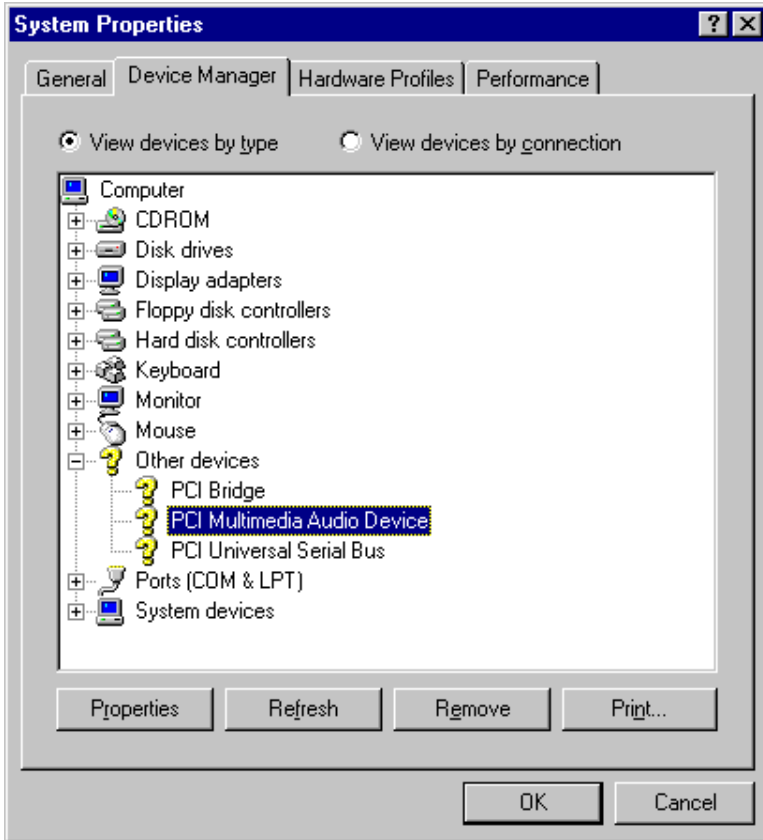

Confirm the remove command by clicking OK.

6. Click Close.

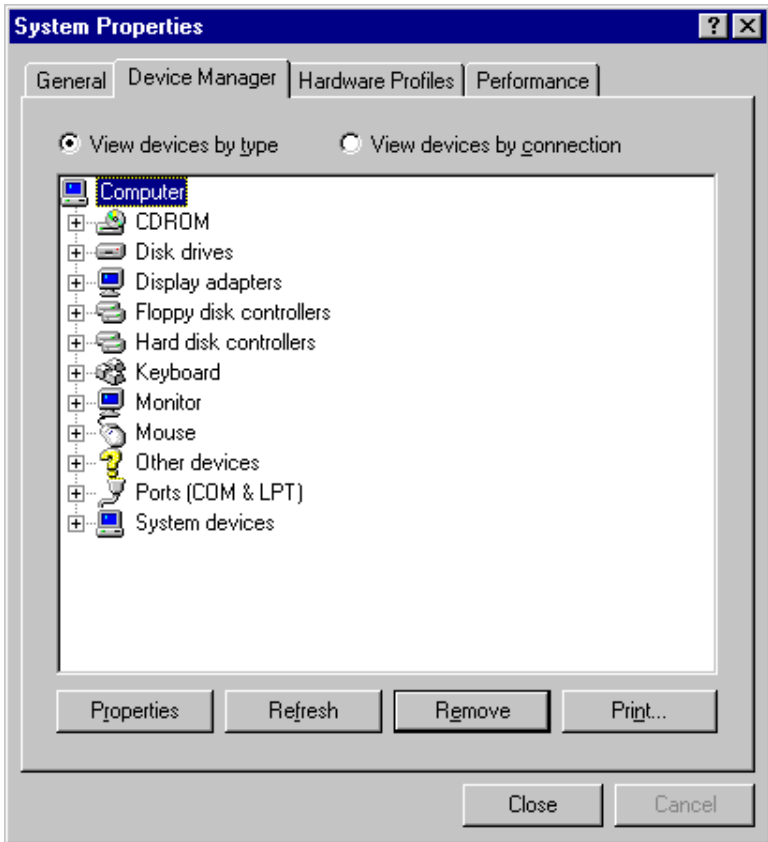

7. Insert the CD that comes with your motherboard into your CD-ROM drive. The following screen will appear.

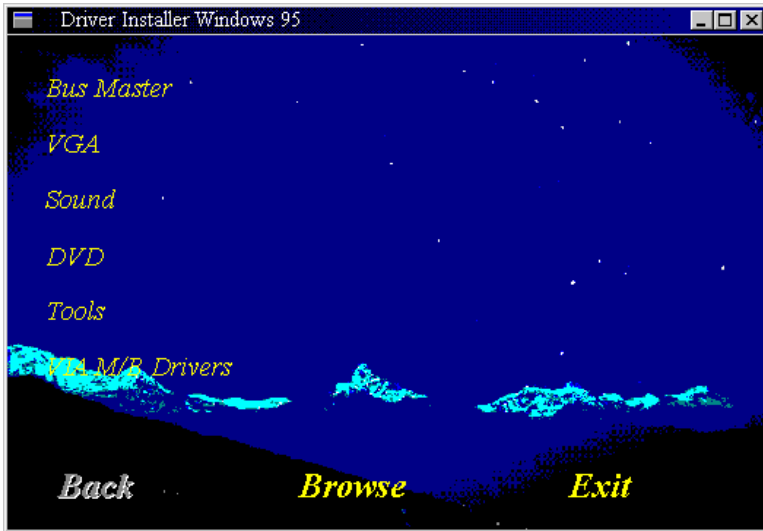

Now click Sound.

8. Click Creative Labs 1373, and then Install.

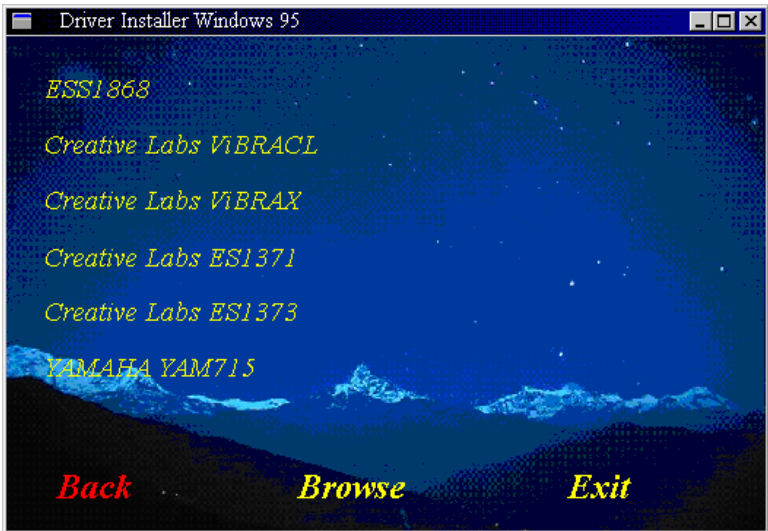

10. Follow the procedure in each screen until you arrive the Setup Option screen as shown below, then select Full Installation.

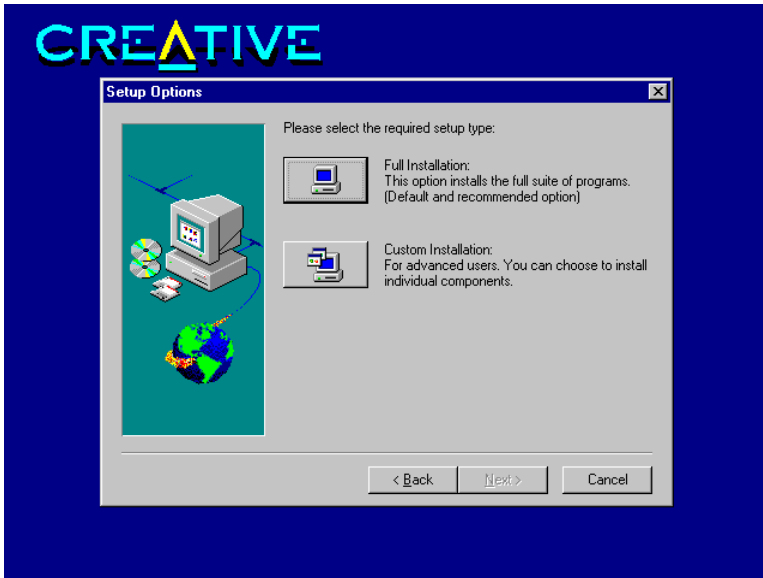

11. Proceed with Setup to install the Windows 95/98 Drivers, Legacy DOS Drivers into your system.

12. After installation, the system will ask you to restart your computer for the changes to take effect.

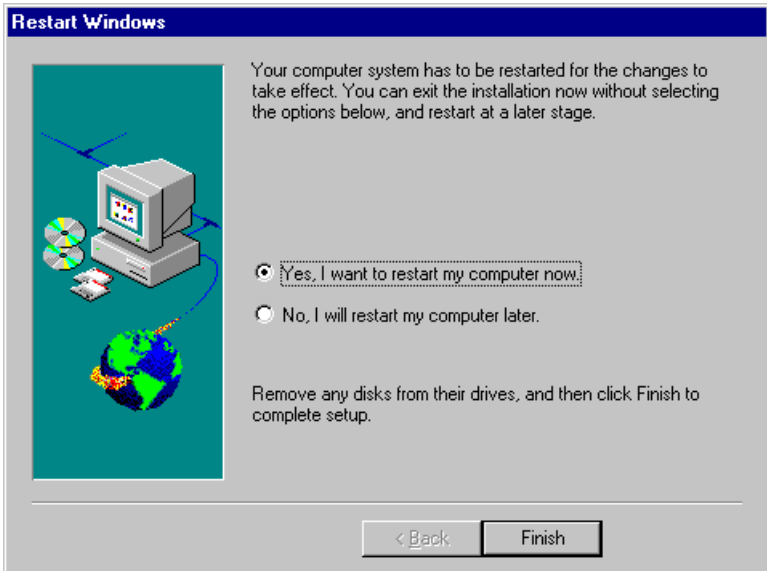

Chapter 8 VGA Driver Installation Guide

This chapter describes the VGA onboard with the installation procedures necessary to take advantage of the features of the ATI 3D RAGE LT PRO. The topics covered in this chapter are as follows:

8.1 Introduction.....	77
8.2 Windows 95/98 Driver Installation.....	78
8.3 Windows NT 4.0 Driver Installation.....	83

8.1 Introduction

The onboard *ATI 3D RAGE LT PRO* utilizes AGP (Accelerated Graphics Port) bus to achieve rich 3D and video graphics display. It enables 3D graphics capabilities including support for z-buffering, alpha blending and faster texture mapping. Onboard TV-out connectors support S-VHS and RCA specifications. The unique features of the *3D RAGE LT PRO* are as follows:

- **TV-Out.** An integrated TV encoder with on-chip triple-DAC allows simultaneous CRT/LCD/TV output.
- **Dual CRT Controller Support.** Two independent CRT controllers support two asynchronous simultaneous displays (LCD/CRT, CRT/TV)
- **Floating-Point Set-up Engine.** The *3D RAGE LT PRO* integrates a floating-point set-up engine capable of processing up to 1.2 million triangles per second. By off-loading the set-up function from the CPU, allowing it to focus on 3D geometry and lighting transformation, the *3D RAGE LT PRO* dramatically improves the performance of the entire 3D pipeline.
- **DVD and Video Support.** DVD and video features include enhanced motion compensation acceleration and a 4-tap horizontal and 2-tap vertical high quality DVD video scaler, providing smooth images without the jagged edges common to today's video products. The scaler provides true color video display, independent of the graphics mode used.
- **AGP 2X mode.** With AGP 2X (133MHz) mode support, the *3D RAGE LT PRO* offers a peak bandwidth in excess of 500MB/s, which is twice the output of the AGP 1X (66MHz) mode. It also supports AGP's pipeline and sideband protocols that significantly improved the sustained bandwidth that is critical to the enhanced 3D and video performance.

8.2 Windows 95/98 Driver Installation

In order to attain higher performance, additional resolutions and special features not available in standard VGA drivers, you must install the enhanced drivers. A CD containing the VGA drivers for *3D RAGE LT PRO* is provided with the motherboard. Follows the steps below to proceed with the VGA driver installation for Windows 95/98.

Step 1. Insert the CD containing the VGA drivers. Under Windows 95/98, the CD autoruns and shows the following screen.

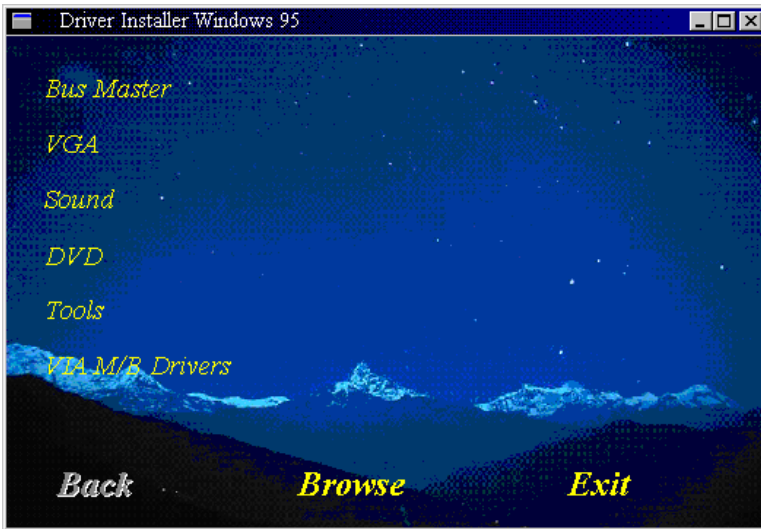

Step 2. Click on VGA to select the correct VGA driver as shown in the following screen.

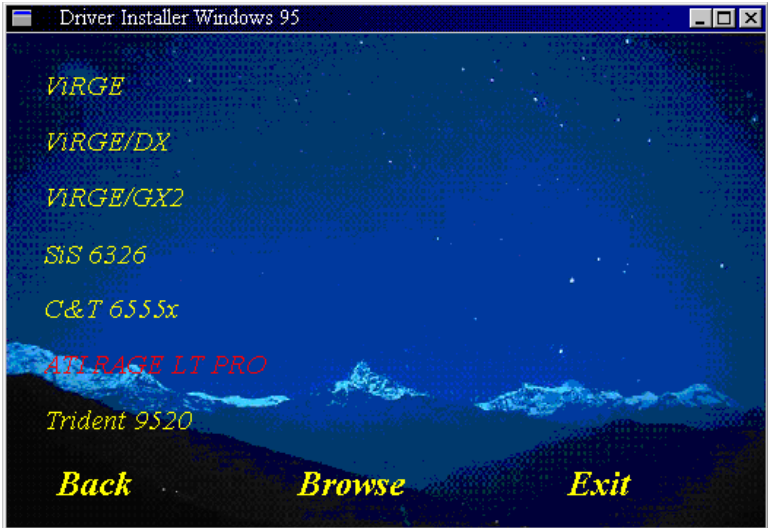

Step 2. Click on *ATI RAGE LT PRO* to start the VGA driver installation. The following welcoming screen appears. Click on Finish to start the driver installation.



Step. 3 When file copying is completed, restart Windows in order for the changes to take effect.

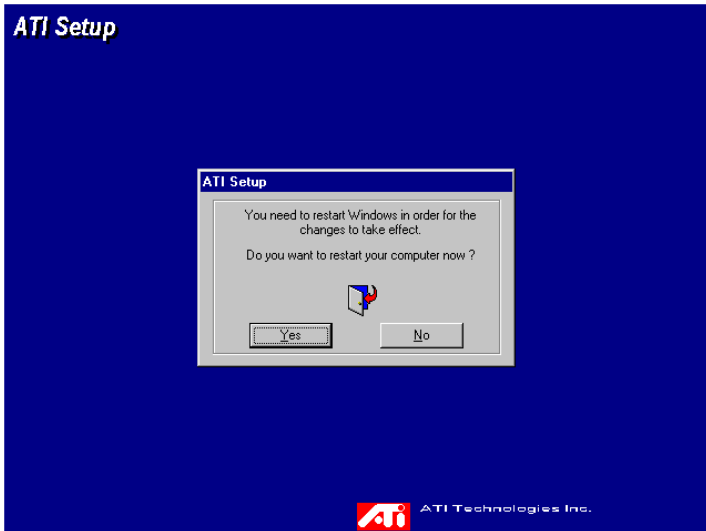

Step. 4 When Windows has restarted the following ATI Desktop Help screen appears to provide you with more information.

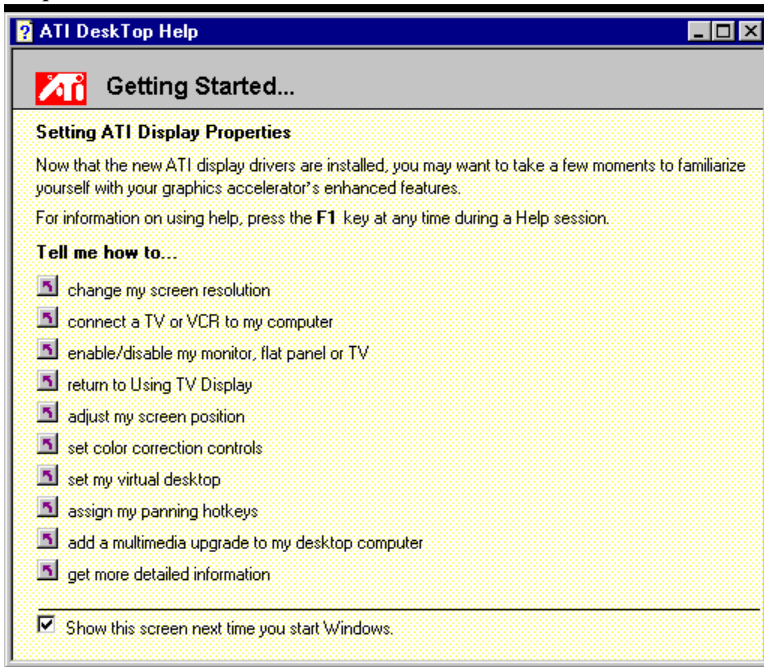

8.3 Windows NT 4.0 Driver Installation

IMPORTANT: You should install the Windows NT 4.0 Service Pack 3 first before installing the *ATI 3D RAGE LT PRO* VGA drivers. If you don't have the Windows NT 4.0 Service Pack 3, please contact your software vendor or download it from Microsoft's web site.

Follows the steps below to proceed with the VGA driver installation for Windows NT 4.0

- Step 1. Run the **Display** program located in the Control Panel, under Settings in the Start menu. Alternatively, position the cursor on the background of the desktop, click the right mouse button, and then select Properties from the popup menu.
- Step 2. Select the **Settings** page.
- Step 3. Select **Display Type....**
- Step 4. Select **Change...** from the display options.
- Step 5. Select **Have Disk...**
- Step 6. Windows NT 4.0 will prompt you for the correct path. Enter **D:\VGA\LT-PRO\WINNT40** (if D: is your CD-ROM drive) or **A:** (if you are using floppy diskettes)
- Step 7. A list of ATI graphics accelerators will be displayed. Select **ATI Technologies Inc. 3D Rage LT Pro xxxx** (xxxx refers to the language.), and then click the **OK** button.
- Step 8. Windows NT 4.0 will once again prompt for confirmation. All appropriate files are then copied to the hard disk.
- Step 9. Restart Windows NT 4.0. Windows NT 4.0 will start up using the ATI drivers.
- Step 10. NT 4.0 will boot into a default mode and start the Display applet allowing for mode selection.

NOTE: If you select a color depth or resolution not supported by your card, NT 4.0 will substitute 640x480 in 256 colors for the display.

Chapter 9 LAN Driver Installation Guide

This chapter gives a brief introduction to the Intel 82558 Fast Ethernet PCI controller.

The following items are covered in this chapter:

9.1 Introduction.....	
9.2 Features.....	
9.3 Software Drivers Support.....	
9.4 LAN Driver Installation for Windows 95.....	81
9.5 LAN Driver Installation for Windows NT 4.0.....	90
9.6 Running Diagnostics.....	91

9.1 Introduction

Intel 82558B is a 32-bit 10/100Mbps Ethernet controller for PCI local bus-compliant PCs. It supports the bus mastering architecture, and Auto-negotiation feature which make it possible to combine one common type of Ethernet cabling – an RJ-45 connector for twisted-pair cabling that can be used for both 10Mbps and 100Mbps connection. Extensive driver support for commonly used network operating systems is also provided.

9.2 Features

- Conforms to the Ethernet IEEE 802.3u standard
- Compatible with PCI Local Bus Revision 2.1 specification
- IEEE 802.3u Auto-Negotiation for automatic speed selection
- Supports Full-Duplex/Half-Duplex Operation
- Provides 32-bit bus mastering data transfer
- Supports 10Mbps and 100Mbps operation in a single port
- Supports remote wake-up (Magic Packet*) in APM and ACPI mode

* *Requires ATX power supply with 5VSB, 720mA*

9.3 Software Drivers Support

NetWare ODI Drivers

Novell NetWare 3.x, 4.x, NetWare LAN WorkPlace TCP/IP, Novell LAN Analyzer for NetWare

Packet Drivers

FTP PC/TCP, NCSA TCP/IP

NDIS Drivers

Microsoft LAN Manager V2.x, Windows 3.x, Windows NT 4.0, Windows NT 3.51, Windows 98, Windows 95, SCO3, SCO5; IBM LAN Server 4.0 for DOS and OS/2, and Linux

9.4 LAN Driver Installation for Windows 95

The LI6BM comes with a diskette labeled Intel 82558B LAN Windows 95/98 & Windows NT 4.0 Drivers that is to be used in conjunction with the LAN drivers installation. You must use the correct drivers in order for LAN to function properly. Follow the steps below to install the drivers for Windows 95.

1. Click Start ⇒ Select Settings ⇒ Select Control Panel.

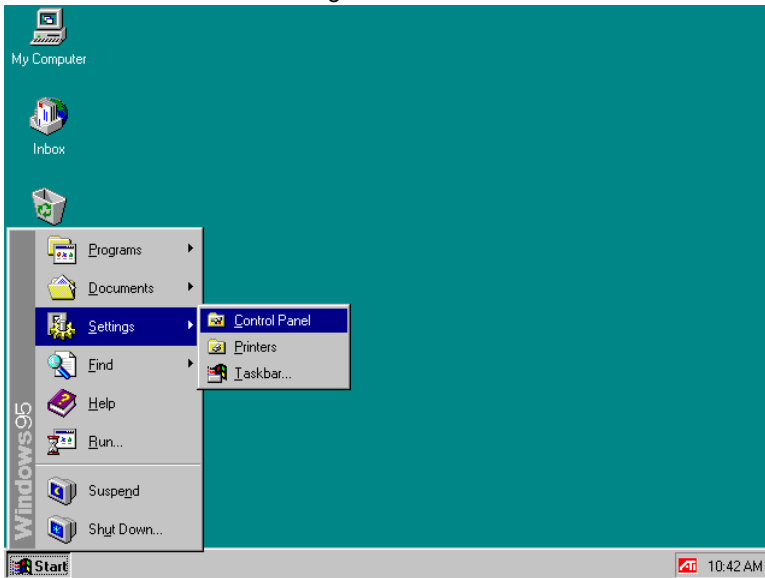

2. Click System.



3. Click Device Manager.

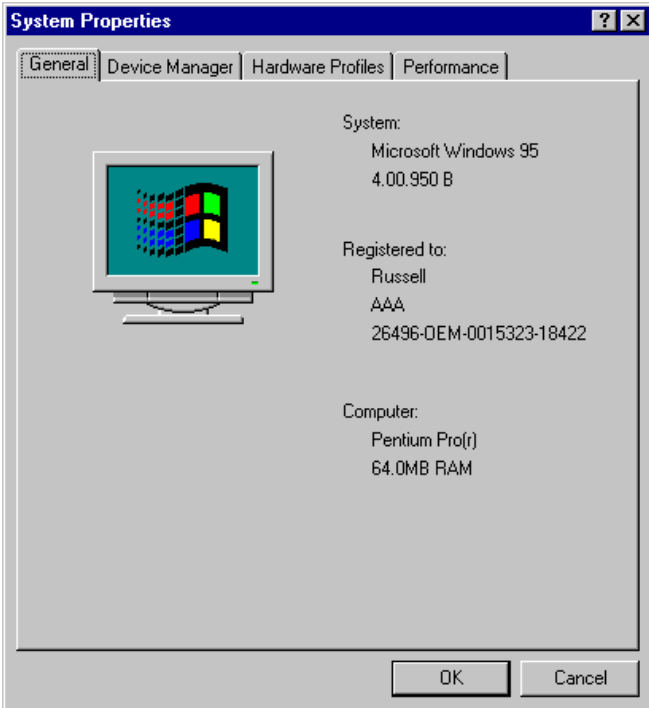

4. Expand Other Devices.

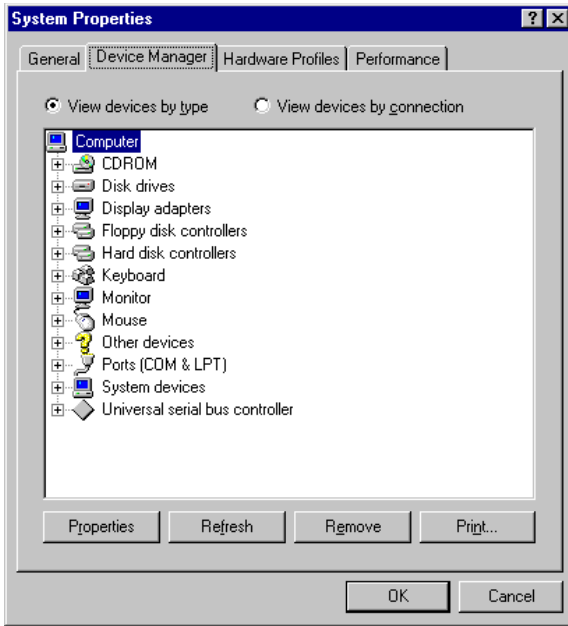

5. Select PCI Ethernet Controller, then click Properties.

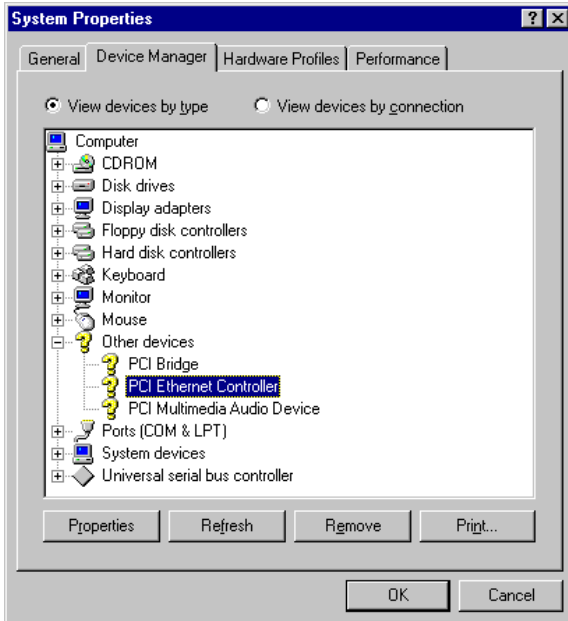

6. Click Driver.

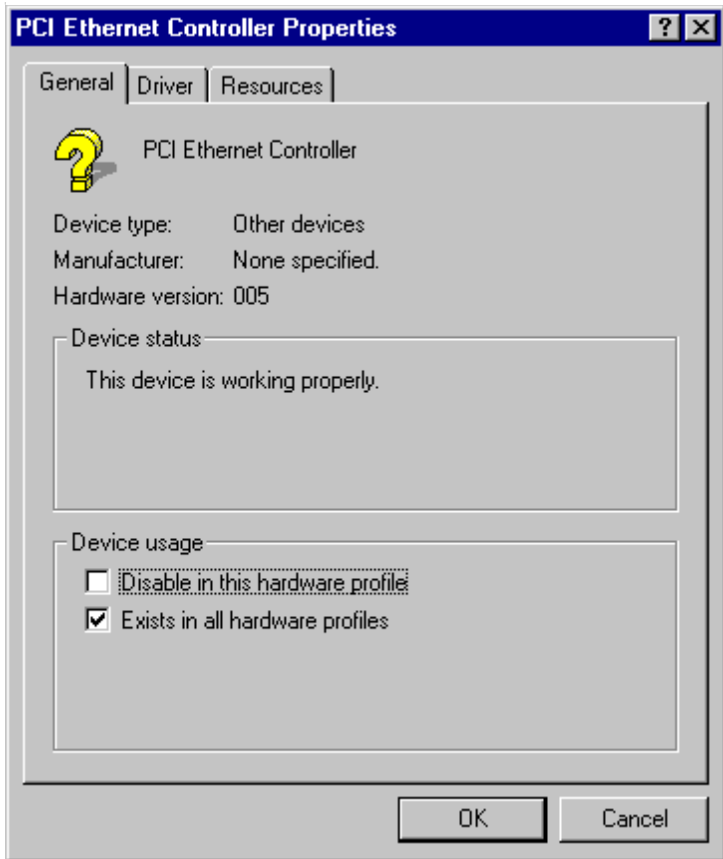

7. Click Update Driver.

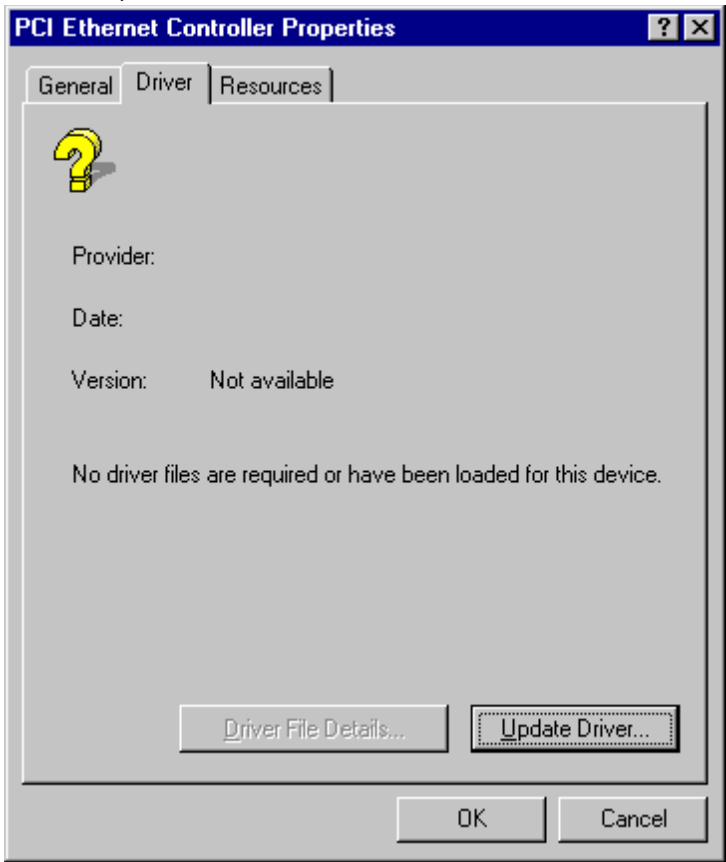

8. Insert the diskette labeled Intel 82558B LAN Windows 95/98 & Windows NT 4.0 Drivers into the floppy disk drive, then click Next.



9. Click Finish. Ensure the updated driver mentioned is for Intel 82558 Fast Ethernet.

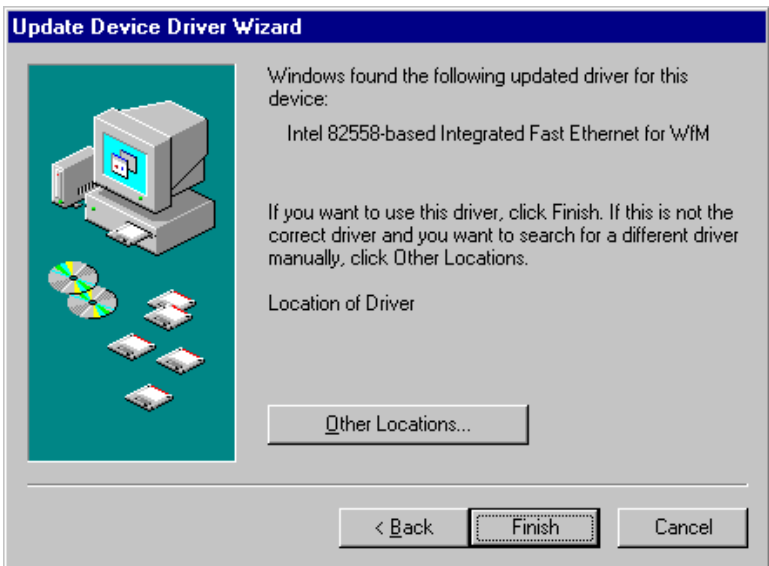

10. Click OK.

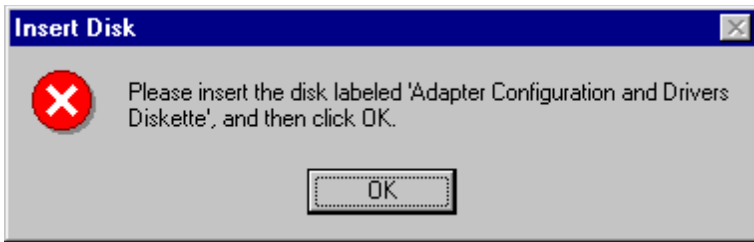

11. Type A:\, then click OK.

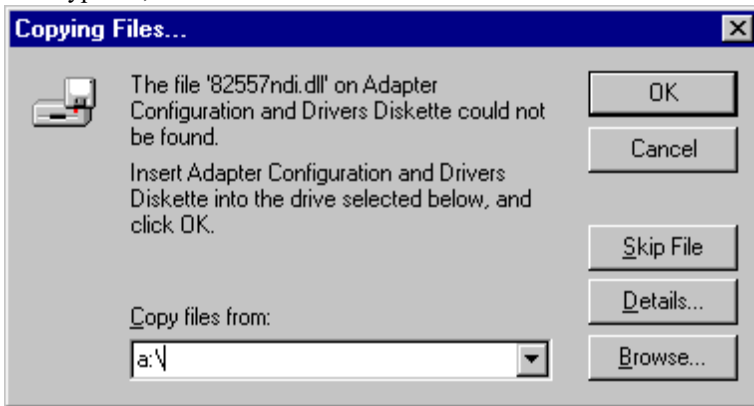

12. Click OK.

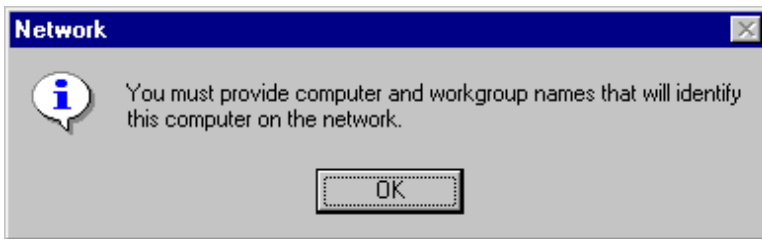

13. Type the Computer Name and Workgroup, then click Close.

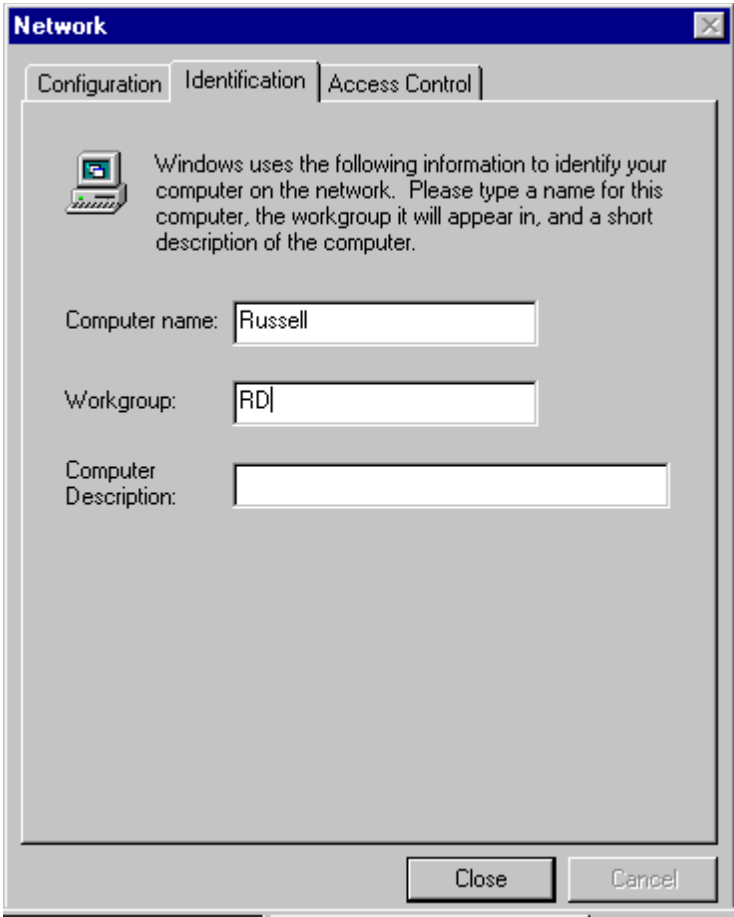

14. Insert the Windows 95 CD ROM, then click OK.

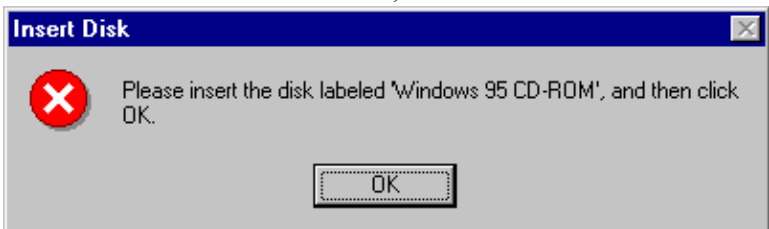

15. Type D:\Win95 (Assuming D:\Win95 is the directory location of the Windows 95 files), then click OK.

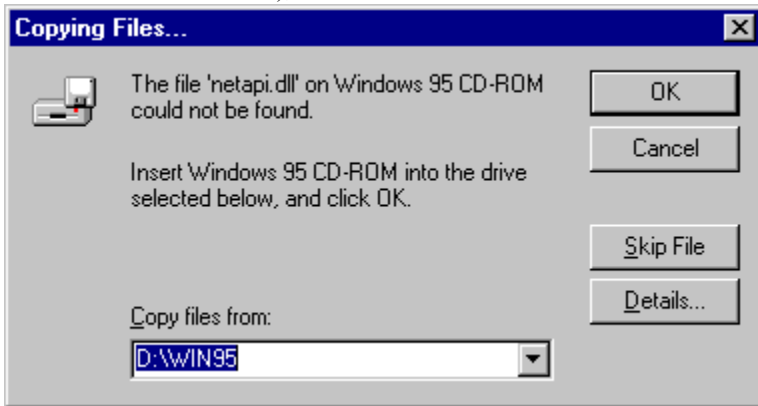

16. Click Yes to restart the computer and for the settings to take effect.



9.5 LAN Driver Installation for Windows NT 4.0

LI6BM comes with a diskette labeled Intel 82558B LAN Windows 95/98 & Windows NT 4.0 Drivers that is to be used in conjunction of the LAN drivers installation. Follow the steps below to install the drivers for Windows NT 4.0.

1. Click Start ⇒ Settings ⇒ Control Panel.
2. Click Network.
3. Click Yes.
4. Select Wired to the network, then click Next.
5. Click from the list.
6. Click Have Disk.
7. Insert the diskette labeled Intel 82558B LAN Windows 95/98 & Windows NT 4.0 Drivers into the floppy disk drive then click OK.
8. Click OK.
9. Click Next.
10. Select the Protocol that you want then click Next.
11. Select Network Services then click Next.
12. Click Next.
13. Insert the Windows NT 4.0 CD into the CD-ROM drive. Type d:\ then click Continue.
14. Click OK.
15. Click Next.
16. Click Next.
17. Type your Workgroup then click Next.
18. Click Finish.
19. Click Yes to restart the computer and for the settings to take effect.

9.6 Running Diagnostics

The LI6BM comes with a diskette containing a diagnostic software supporting the Intel 82558B Ethernet controller. Follow the steps below to use the *Setup Utility*.

1. Run the file SETUP.EXE typing `a:\setup` in the DOS prompt, assuming your floppy disk drive is drive A. Upon doing so, the system starts the *Setup Utility* and shows the following screen.

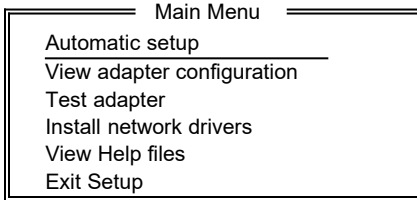
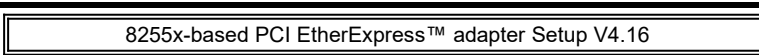

Choose AUTOMATIC SETUP to view the adapter's configuration, make sure it works properly, and install the software needed to connect to your network.

Help = F1 Exit = Esc Select = ↑↓ Action = ↵

2. Selecting View adapter configuration will show the following.

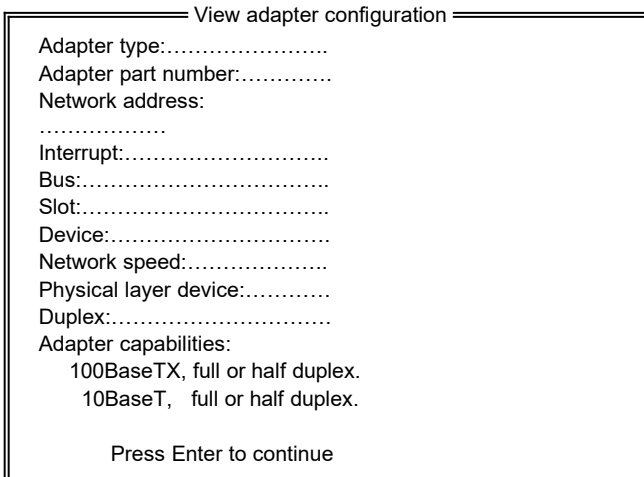
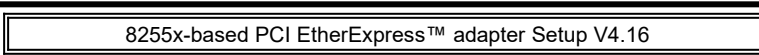

Help = F1 Previous = Esc Continue = Enter PCI Advanced = F5

3. Selecting Test adapter will show the following screen.

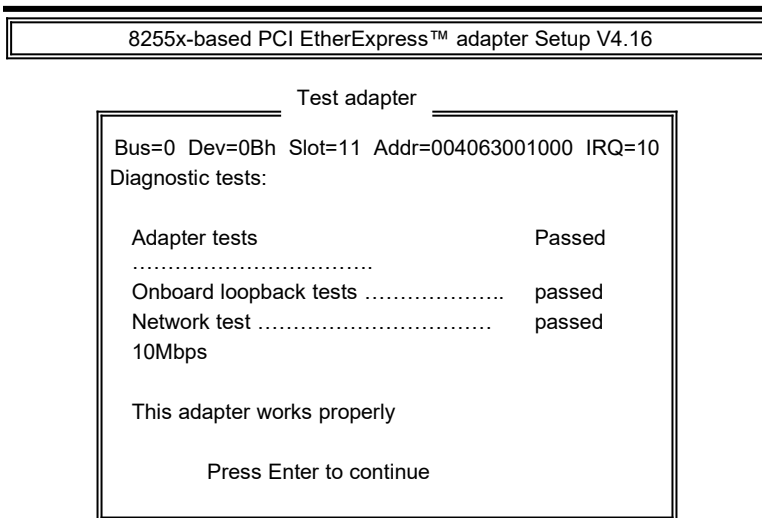

Help = F1 Press Enter to continue

4. Selecting Install network drivers will show the following screen.

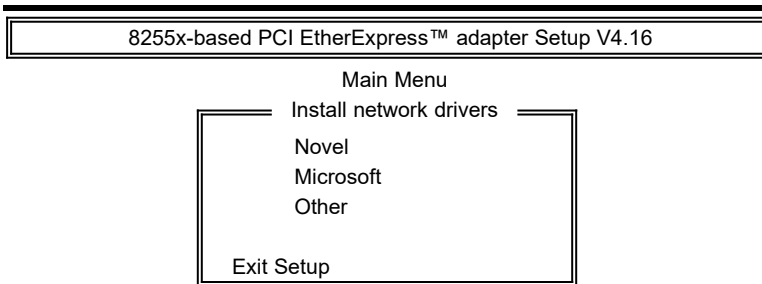

Choose OTHER if you use a network operating system from a manufacturer not on this list (such as Banyan or UNIX).

Help = F1 Press Enter to continue

Chapter 9 LAN Driver Installation Guide

5. Upon selecting Others under the Install network drivers main menu screen, the following screen will appear.

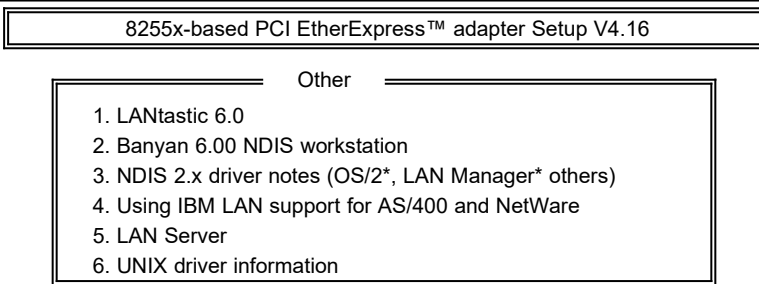

Choose OTHER if you use a network operating system from a manufacturer not on this list (such as Banyan or UNIX).

Help = F1 Previous = Esc Select = ↑↓ Accept = ↵

6. Selecting View Help files under the Main menu will show the following screen.

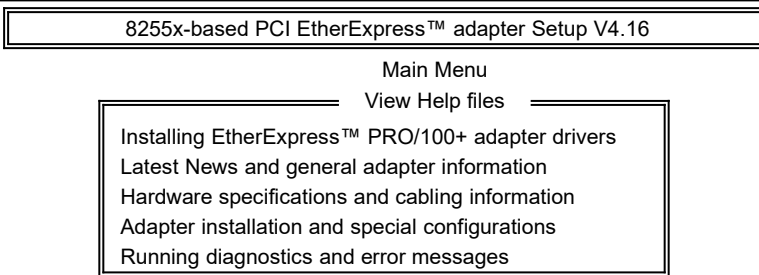

Help = F1 Previous = Esc Select = ↑↓ Display Choices = ↵

This page was intentionally left blank.

Chapter 10 System Monitor Utility User's Guide

This chapter introduces System Monitor Utility that comes with the motherboard in conjunction with the onboard hardware monitoring IC. The sections below give the functions of the utility.

System Monitor is a software utility that oversees the general performance of systems, covering areas like system temperature, system voltage, CPU and system fan rotational speeds. If conditions become adverse, that is, when voltages are erratic or CPU temperature exceeds the safe limits, an alarm will be sounded; thereby preventing system crashing and ensuring overall stability.

***NOTE:** System Monitor currently supports English and Chinese under Windows 95 and Windows NT. English will be used for other language environments.*

When System Monitor is initiated, the icon below appears in the task bar in the Windows environment.



The following screen appears upon clicking on the System Monitor icon.

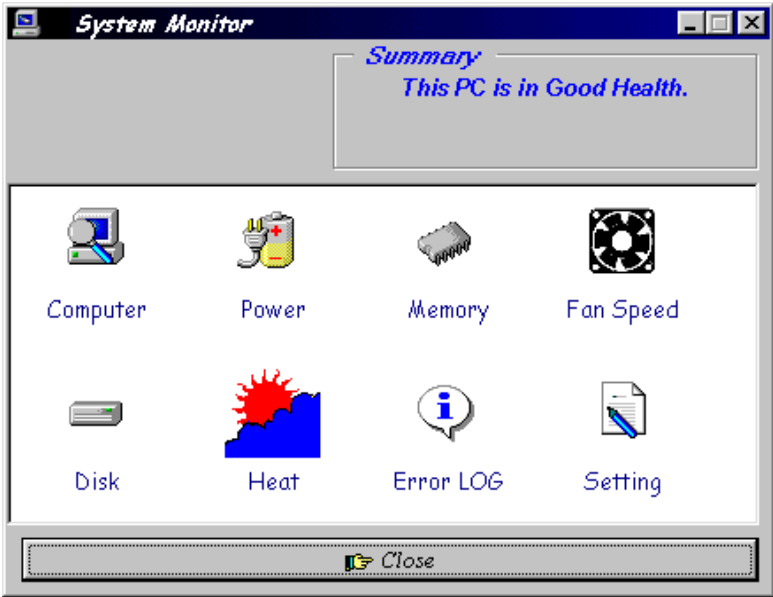

Clicking on the upper left corner button would show you the latest company information. "Summary" provides the current system status.

The section below describes the different functions of System Monitor.

1. Computer - displays the current working system version and processor type.

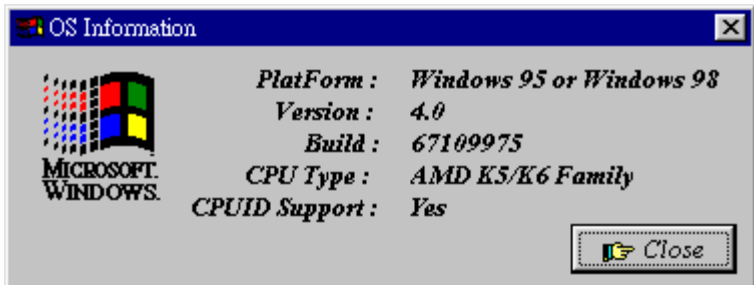

2. Power - displays the current voltage status.

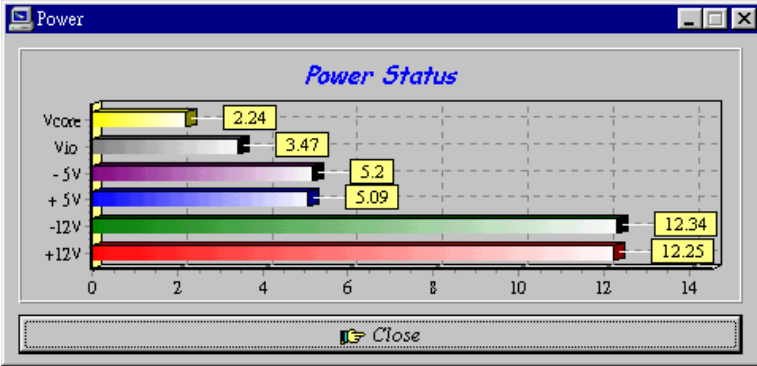

3. Memory - displays the current memory usage status.

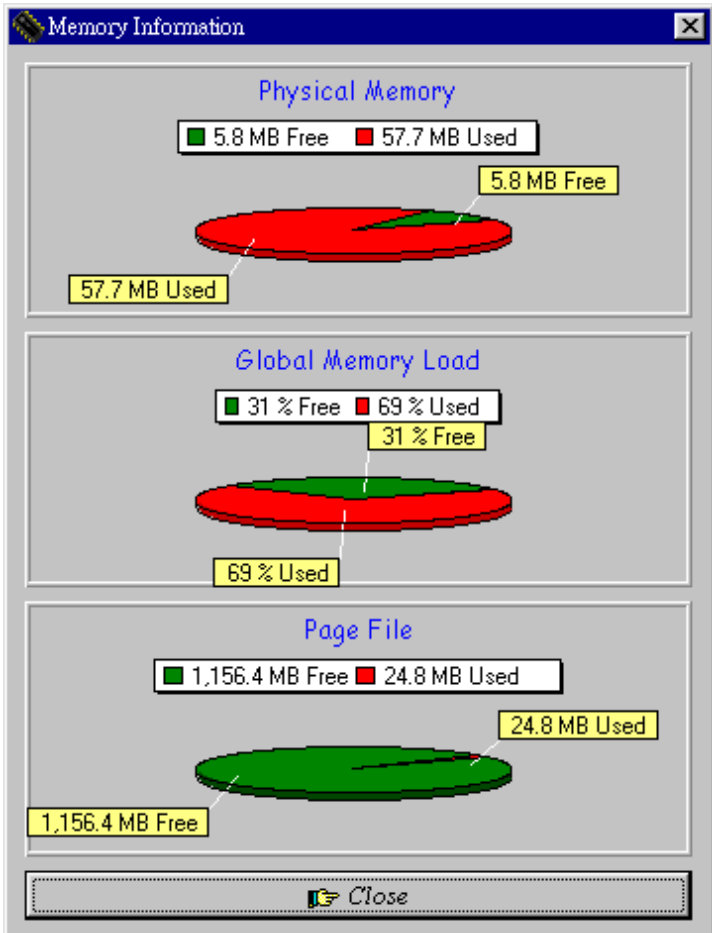

- 4. Fan Speed - displays the current rotational speeds of CPU and Chassis fans.

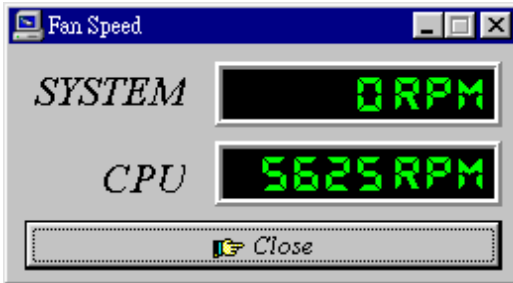

- 5. Disk - displays the supported disk formats and disk space.

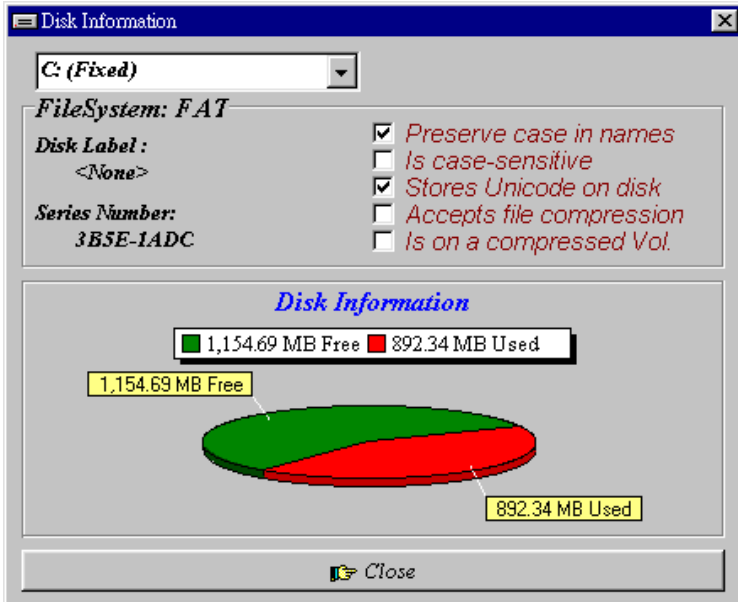

- Heat - displays the CPU and system temperatures.

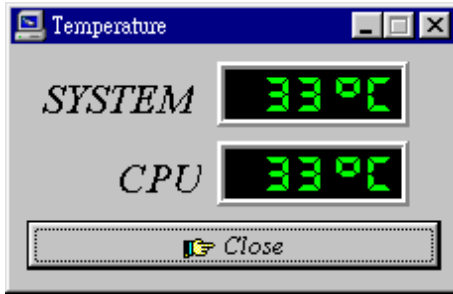

- Error Log - displays errors occurring after System Monitor is started.

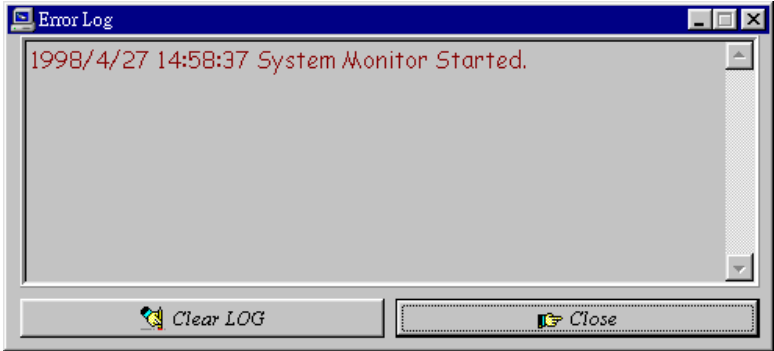

8. Setting - sets the values at which an alarm is sounded.

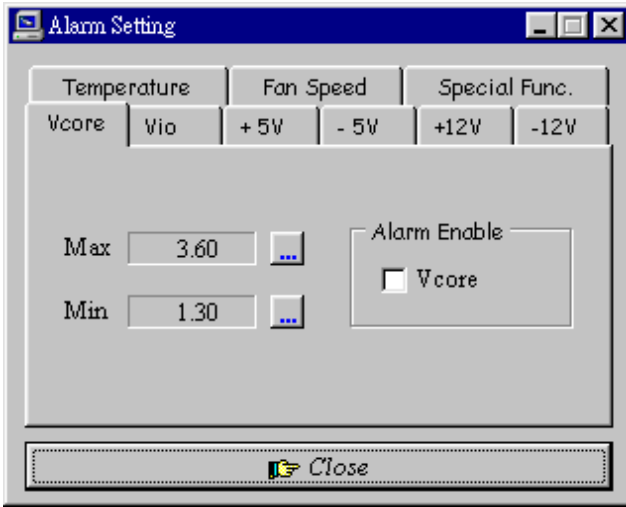

Voltage : the acceptable voltage range between the "MAX" and "MIN" value.

Temperature : temperature threshold.

Fan Rotation Speed : the minimum rotation speed.

NOTE: Intel has defined a margin of difference for the voltages as below:

12 Volts - 10% (10.8V ~ 13.2V)

5 Volts - 5% (4.75 ~ 5.25%)

Vio - 5% (Vio for P54C CPU is 3.5V. Vio for P55C is 3.3V.)

Vcore- 5%

Appendix

A. Slot 1 Retention Mechanism

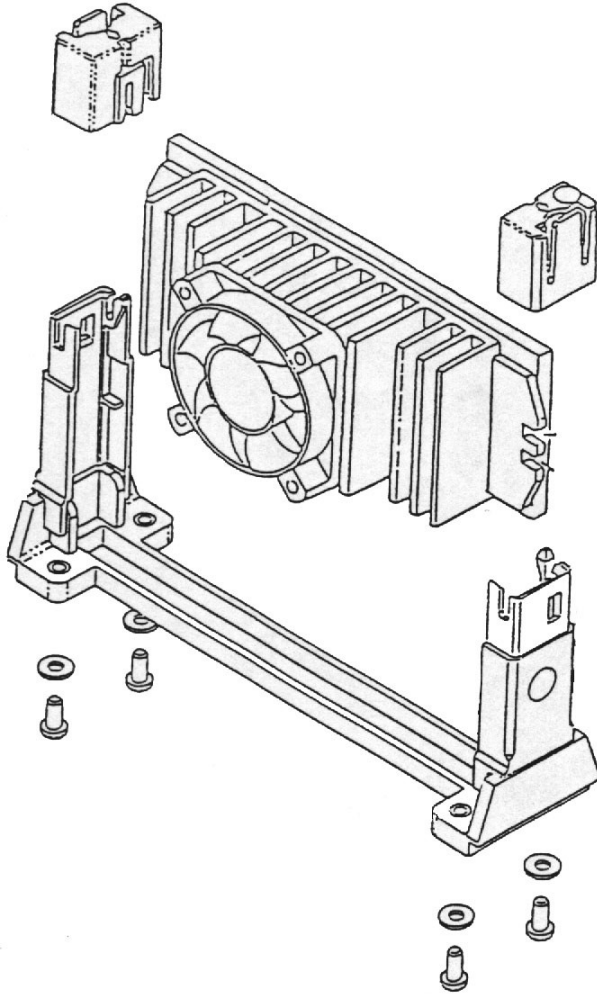

The retention mechanism that comes with your motherboard, as seen in the above figure, accommodates all kinds of Pentium II processors. For **Celeron** processors, place the two caps supplied on both ends after installing the processor to secure the installation.

B. Technical Information regarding TV-Out

The LI6BM motherboard has connectors for RCA (J2) and S-Video (J1) standards supporting the TV-Out function on the motherboard. In order to use the TV-Out function, you should use the appropriate cables to connect your TV set to the computer. Your TV set should also have the corresponding connectors.

When the connection between the computer and TV has been done, you may turn on the system. Remember to set the TV to receive RCA or S-Video signals. The computer system will then determine if there is a TV connected to it and automatically enable the *TV signal output*.

The system will not enable the *TV signal output* if it is not connected to a TV set. Therefore, if you have not done so, turn off the computer, connect the TV set to the computer, and restart the computer to enable the *TV signal output* from the computer.

C. Additions & Errata

This section is allotted for future page inserts containing any additional information or correction that the users should know.