

IPMTB-GS

Motherboard Reference Guide

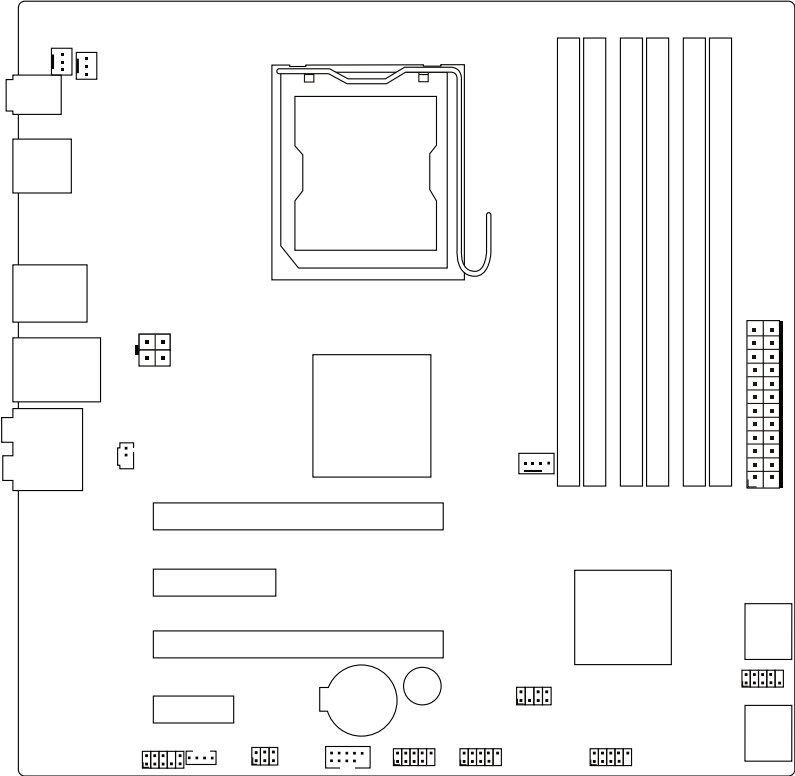

Contents

- Contents2**
- Notices.....3**
- Safety information4**
- Specifications summary5**
- Hardware Installation**
 - 1 Before you proceed 6**
 - Package contents.....6
 - 2 Motherboard layout 7**
 - Top view7
 - Rear panel connectors7
 - 3 Central Processing Unit (CPU) 8**
 - Installing the CPU8
 - Installing the CPU heatsink and fan 10
 - Uninstalling the CPU heatsink and fan..... 11
 - 4 System memory 12**
 - Memory types.....12
 - Memory module rules and configurations12
 - Installing a DIMM.....14
 - Removing a DIMM.....14
 - 5 Expansion slots 15**
 - Installing an expansion card.....15
 - 6 Selectors..... 16**
 - 7 Connectors..... 17**
 - 8 BIOS Setup reference..... 23**
 - Main.....23
 - Advanced24
 - Power25
 - Security26
 - Boot.....28
 - Exit29

Notices

Federal Communications Commission Statement

This device complies with Part 15 of the FCC Rules. Operation is subject to the following two conditions:

- This device may not cause harmful interference, and
- This device must accept any interference received including interference that may cause undesired operation.

This equipment has been tested and found to comply with the limits for a Class B digital device, pursuant to Part 15 of the FCC Rules. These limits are designed to provide reasonable protection against harmful interference in a residential installation. This equipment generates, uses and can radiate radio frequency energy and, if not installed and used in accordance with manufacturer's instructions, may cause harmful interference to radio communications. However, there is no guarantee that interference will not occur in a particular installation. If this equipment does cause harmful interference to radio or television reception, which can be determined by turning the equipment off and on, the user is encouraged to try to correct the interference by one or more of the following measures:

- Reorient or relocate the receiving antenna.
- Increase the separation between the equipment and receiver.
- Connect the equipment to an outlet on a circuit different from that to which the receiver is connected.
- Consult the dealer or an experienced radio/TV technician for help.

NOTE: The use of shielded cables for connection of the monitor to the graphics card is required to assure compliance with FCC regulations. Changes or modifications to this unit not expressly approved by the party responsible for compliance could void the user's authority to operate this equipment.

Canadian Department of Communications Statement

This digital apparatus does not exceed the Class B limits for radio noise emissions from digital apparatus set out in the Radio Interference Regulations of the Canadian Department of Communications.

This class B digital apparatus complies with Canadian ICES-003.

Safety information

Electrical safety

- To prevent electrical shock hazard, disconnect the power cable from the electrical outlet before relocating the system.
- When adding or removing devices to or from the system, ensure that the power cables for the devices are unplugged before the signal cables are connected. If possible, disconnect all power cables from the existing system before you add a device.
- Before connecting or removing signal cables from the motherboard, ensure that all power cables are unplugged.
- Seek professional assistance before using an adapter or extension cord. These devices could interrupt the grounding circuit.
- Make sure that your power supply is set to the correct voltage in your area. If you are not sure about the voltage of the electrical outlet you are using, contact your local power company.
- If the power supply is broken, do not try to fix it by yourself. Contact a qualified service technician or your retailer.

Operation safety

- Before installing the motherboard and adding devices on it, carefully read all the manuals that came with the package.
- Before using the product, make sure all cables are correctly connected and the power cables are not damaged. If you detect any damage, contact your dealer immediately.
- To avoid short circuits, keep paper clips, screws, and staples away from connectors, slots, sockets and circuitry.
- Avoid dust, humidity, and temperature extremes. Do not place the product in any area where it may become wet.
- Place the product on a stable surface.
- If you encounter technical problems with the product, contact a qualified service technician or your retailer.



IMPORTANT: This symbol of the crossed out wheeled bin indicates that the product (electrical and electronic equipment) should not be placed in municipal waste. Check local regulations for disposal of electronic products.

Specifications summary

CPU	Socket : Intel LGA1366 Supports : Bloomfield FSB : Intel QPI
Chipset	North bridge : Intel X58 IOH South bridge : Intel ICH10R
Memory	Triple channels, 6 slots, ECC, 240-pin DDR3, Max. 24GB Types : 800/PC3-6400, 1066/PC3-8500
Expansion slots	2x PCI express slots (x16) 1x PCI express slot (x4) 1x PCI express slot (x1)
Audio	Realtek ALC888S CODEC (8 Channels)
LAN	Intel 82567-V Gigabit LAN
Storage	4x SATA ports (4 onboard headers) SATA300/150 2x eSATA ports
USB	10x USB 2.0 ports (6 onboard, 4 on rear panel)
1394	Via VT6315N
Rear panel I/O ports	1x SPDIF output port 2x eSATA ports (optional) 1x 1394 port + 2x USB ports 1x LAN port + 2x USB ports 6x Audio ports
Internal connectors	1x ATX power connector 1x ATX +12V power connector 1x CPU fan connector 1x System fan connector 1x Chassis fan connector 1x Line-In connector (optional) 1x Front panel audio connector 1x SPDIF output connector 1x IEEE1394 connector 3x USB2.0 connectors 1x ROM recovery connector 1x Front panel connector
BIOS	AMI 8Mb SPI
Form factor	microATX: 9.6 in. x 9.6 in.

*The specifications are subject to change without notice.

Hardware Installation

1 Before you proceed

Take note of the following precautions before you install motherboard components or change any motherboard settings.

- **Unplug the power cord from the wall socket before touching any component.**
 - **Use a grounded wrist strap or touch a safely grounded object or to a metal object, such as the power supply case, before handling components to avoid damaging them due to static electricity.**
 - **Hold components by the edges to avoid touching the ICs on them.**
 - **Whenever you uninstall any component, place it on a grounded antistatic pad or in the bag that came with the component.**
 - **Before you install or remove any component, ensure that the ATX power supply is switched off or the power cord is detached from the power supply. Failure to do so may cause severe damage to the motherboard, peripherals, and/or components.**
 - **Before you install the motherboard, study the configuration of your chassis to ensure that the motherboard fits into it.**
 - **Make sure to unplug the power cord before installing or removing the motherboard. Failure to do so can cause you physical injury and damage motherboard components.**
-

Package contents

Check your package for the following items.

Motherboard	1x IPMTB-GS
Cables	
Accessories	1x I/O shield
Support disc	1x Drivers & Utilities
Documentation	1x This Motherboard Reference Guide

2 Motherboard layout

Top view

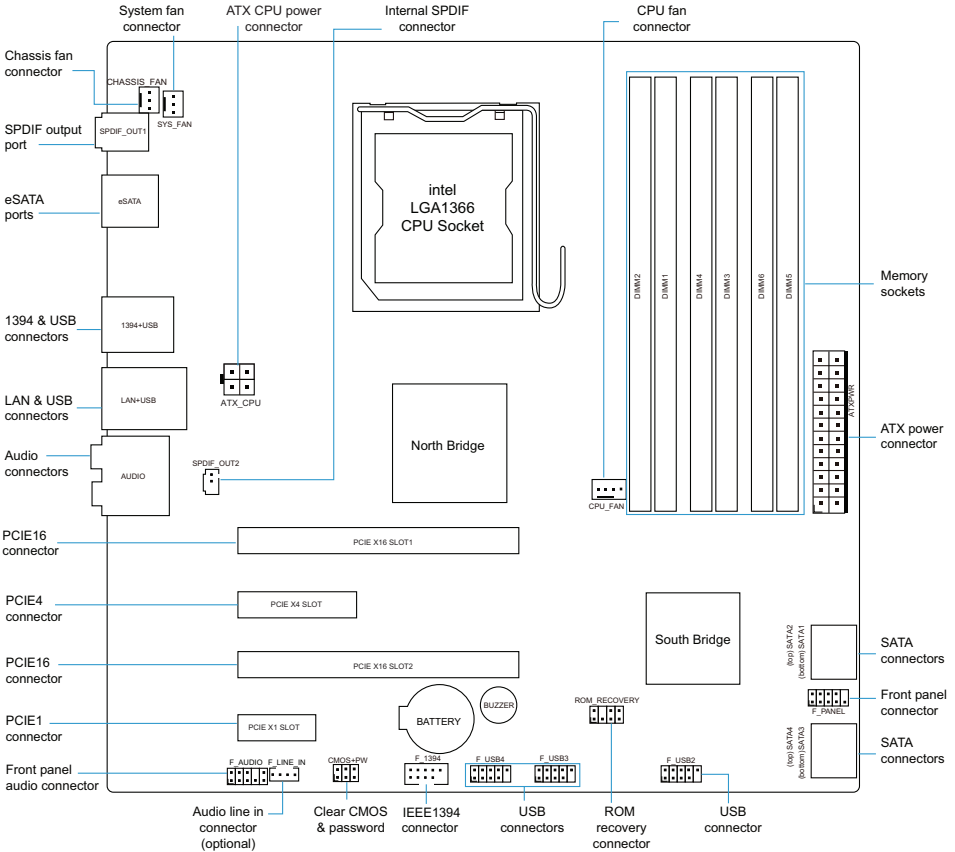

Rear panel connectors

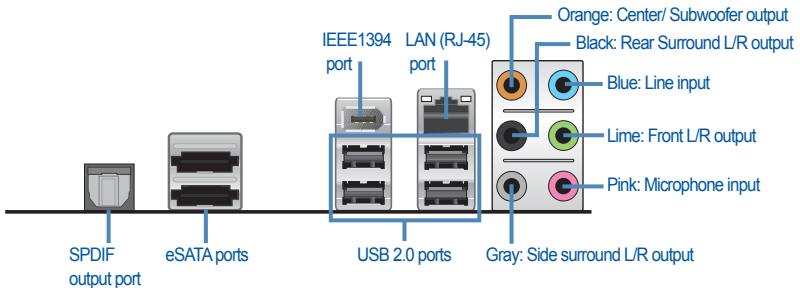

3 Central Processing Unit (CPU)

The motherboard comes with a surface mount socket designed for various processors.

NOTE: Your boxed processor package should come with installation instructions for the CPU, fan and heatsink assembly. If the instructions in this section do not match the CPU documentation, follow the latter.

NOTE: Upon purchase of the motherboard, make sure that the socket cap is on the socket and the socket pins are not bent. Contact your retailer immediately if the socket cap is missing, or if you see any damage to the socket cap/socket pins/motherboard components.

NOTE: Keep the cap after installing the motherboard. It is required for product returns or repairs.

NOTE: The product warranty does not cover damage to the socket pins resulting from incorrect CPU installation/removal, or misplacement/loss/incorrect removal of the socket cap.

Installing the CPU

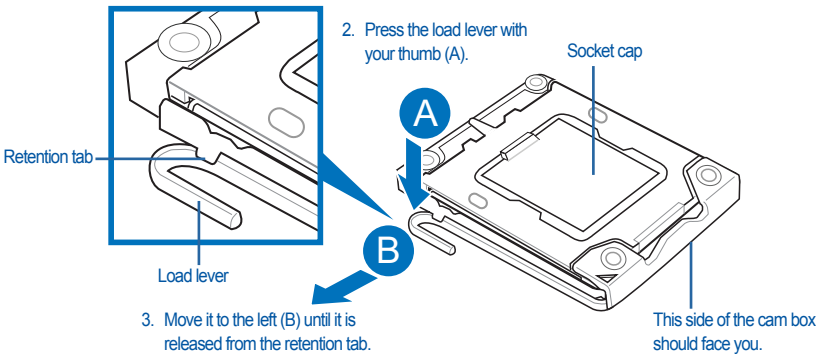
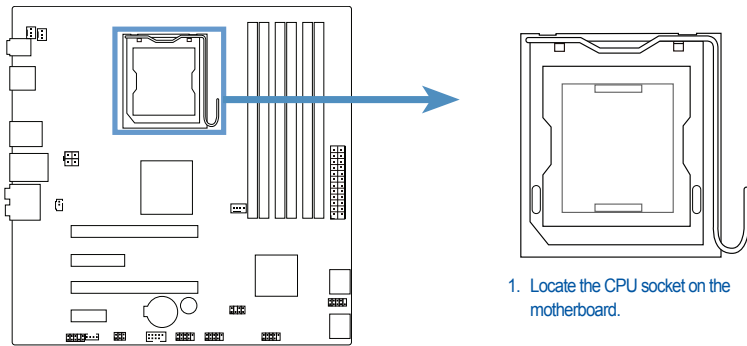

NOTE: To prevent damage to the socket pins, do not remove the socket cap unless you are installing a CPU.

3 Central Processing Unit (CPU)

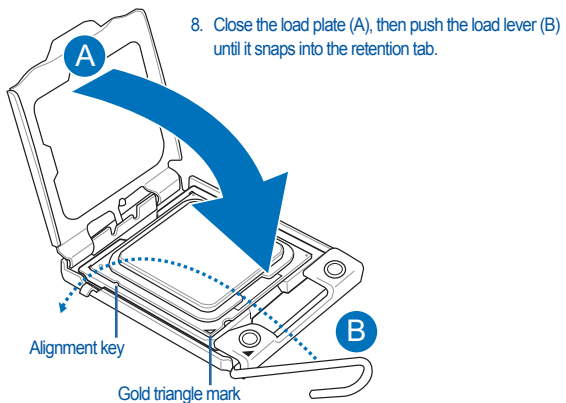
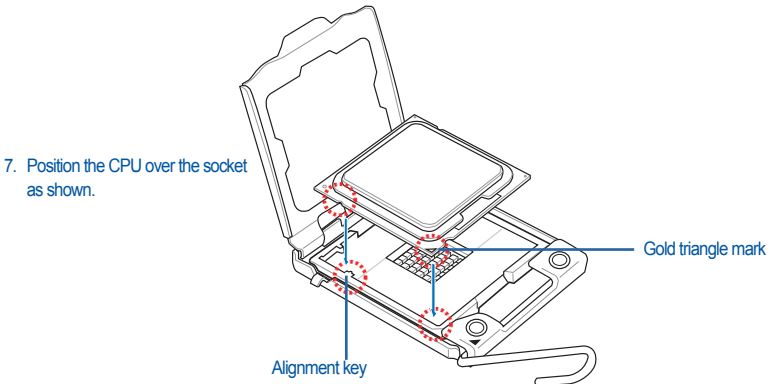
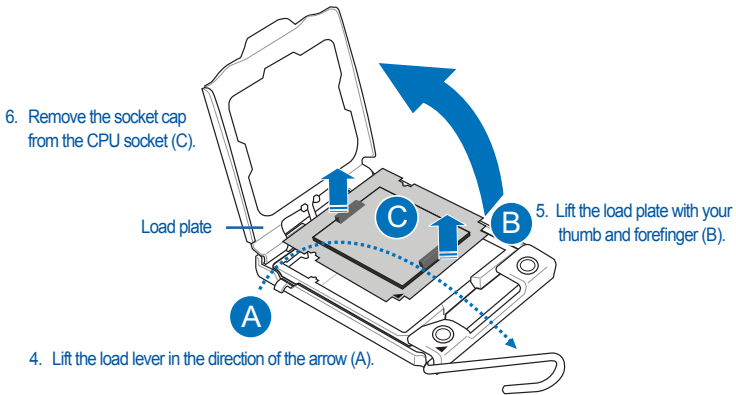

NOTE: The CPU fits in only one correct orientation. DO NOT force the CPU into the socket to prevent damaging the delicate CPU!

3 Central Processing Unit (CPU)

Installing the CPU heatsink and fan

The processor require a specially designed heatsink and fan assembly to ensure optimum thermal condition and performance. When you buy a boxed processor, the package includes the CPU fan and heatsink assembly.

NOTE: Install the motherboard to the chassis before you install the CPU fan and heatsink assembly

NOTE: If you buy a CPU separately, make sure that you use only Intel®-certified multi-directional heatsink and fan and make sure that a Thermal Interface Material is properly applied to the CPU heatsink or CPU before you install the the heatsink and fan assembly.

1. Place the heatsink on top of the installed CPU, making sure that the four fasteners match the holes on the motherboard.

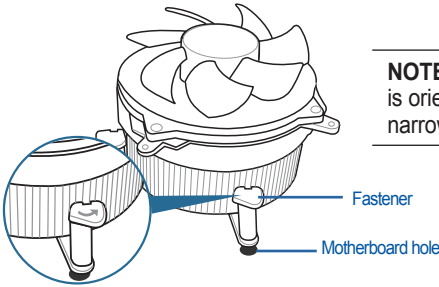

NOTE: Make sure each fastener is oriented as shown, with the narrow groove directed outward.

2. Push down two fasteners at a time in a diagonal sequence to secure the heatsink and fan assembly in place.

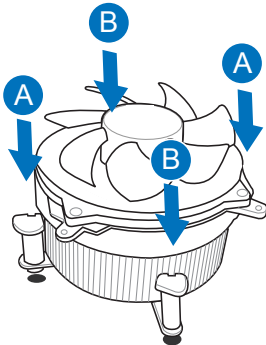

3. When the fan and heatsink assembly is in place, connect the CPU fan cable to the connector on the motherboard.

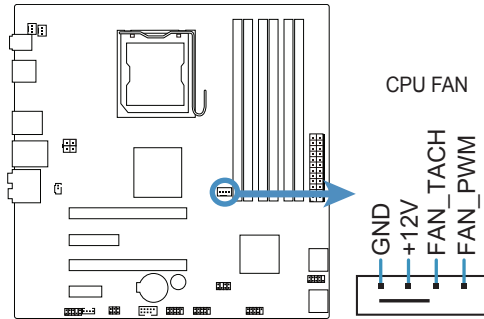

3 Central Processing Unit (CPU)

Uninstalling the CPU heatsink and fan

1. Disconnect the CPU fan cable from the connector on the motherboard.
2. Rotate each fastener counterclockwise.

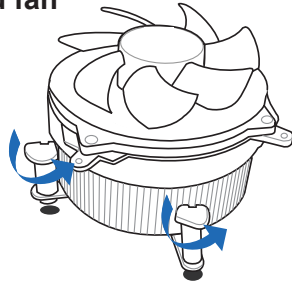

3. Pull up two fasteners at a time in a diagonal sequence to disengage the heatsink and fan assembly from the motherboard.

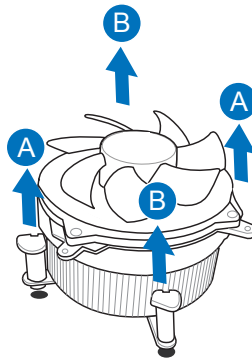

4. Remove the heatsink and fan assembly from the motherboard.

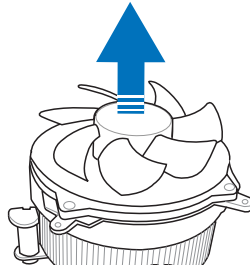

5. Rotate each fastener clockwise to reset the orientation.

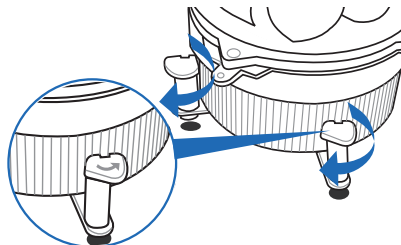

NOTE: The narrow end of the groove should point outward after resetting.

4 System memory

Memory types

The motherboard comes with Double Data Rate 3 (DDR3) Dual Inline Memory Modules (DIMM) sockets.

WARNING: Only DDR3 RAM modules can be used on this motherboard.

The figure illustrates the location of the DDR3 DIMM sockets:

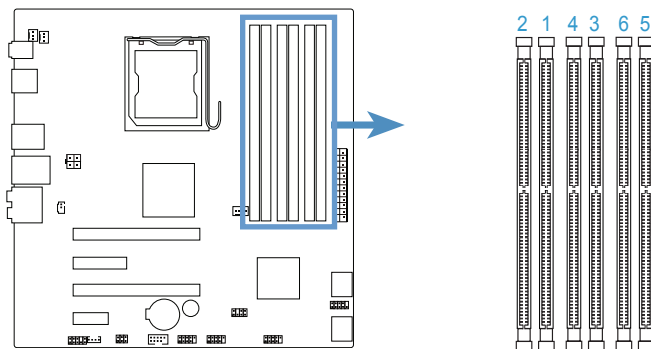

IMPORTANT: Always install DIMMs with the same CAS latency. For optimum compatibility, it is recommended that you obtain memory modules from the same vendor.

Memory module rules and configurations

DIMM Socket Labeling

Socket Color and Channel					
DIMM2 Black	DIMM1 Blue	DIMM4 Black	DIMM3 Blue	DIMM6 Black	DIMM5 Blue
(Channel A)	(Channel A)	(Channel B)	(Channel B)	(Channel C)	(Channel C)

Note: DIMM2 is the socket closest to the CPU and DIMM5 is the socket farthest from the CPU.

Memory Module Insertion Rule

1. Insert modules starting from the DIMM closest to the CPU.
2. Insert 2GB modules first, then 1GB modules if both are used.
3. Fill each channel (two sockets) with modules to fully utilize triple channel performance.

IMPORTANT: One of the blue sockets (DIMM1/3/5) must be populated.

4 System memory

Possible Memory Configurations

System Memory	Memory Channel Configuration	DIMM 2 (Ch A, Black)	DIMM 1 (Ch A, Blue)	DIMM 4 (Ch B, Black)	DIMM 3 (Ch B, Blue)	DIMM 6 (Ch C, Black)	DIMM 5 (Ch C, Blue)
2GB	Dual	-	1GB	-	1GB	-	-
3GB	Triple	-	1GB	-	1GB	-	1GB
4GB	Dual	-	2GB	-	2GB	-	-
4GB	Triple (unbalanced)	-	2GB	-	1GB	-	1GB
5GB	Triple (unbalanced)	-	2GB	-	2GB	-	1GB
6GB	Triple	-	2GB	-	2GB	-	2GB
7GB	Triple (unbalanced)	1GB	2GB	-	2GB	-	2GB
8GB	Triple (unbalanced)	2GB	2GB	-	2GB	-	2GB
9GB	Triple	1GB	2GB	1GB	2GB	1GB	2GB
9GB	Triple (unbalanced)	2GB	2GB	1GB	2GB	-	2GB
10GB	Triple (unbalanced)	2GB	2GB	2GB	2GB	-	2GB
11GB	Triple (unbalanced)	2GB	2GB	2GB	2GB	1GB	2GB
12GB	Triple	2GB	2GB	2GB	2GB	2GB	2GB

4 System memory

Installing a DIMM

WARNING: Unplug the power supply before adding or removing DIMMs or other system components. Failure to do so can cause severe damage to both the motherboard and the components.

To install a DIMM:

1. Unlock a DIMM socket by pressing the retaining clips outward.
2. Align a DIMM on the socket such that the notch on the DIMM matches the break on the socket.
3. Firmly insert the DIMM into the socket until the retaining clips snap back in place and the DIMM is properly seated.

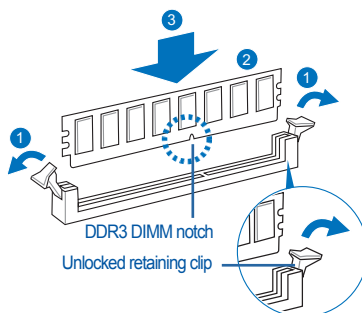

NOTE: A DDR3 DIMM is keyed with a notch so that it fits in only one direction. Do not force a DIMM into a socket to avoid damaging the DIMM.

NOTE: The DDR3 DIMM sockets do not support non-DDR3 DIMMs.

Removing a DIMM

Follow these steps to remove a DIMM:

1. Simultaneously press the retaining clips outward to unlock the DIMM.
2. Remove the DIMM from the socket.

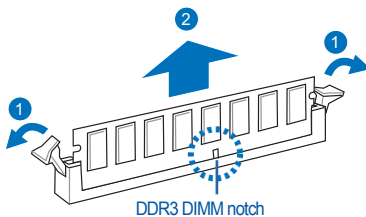

TIP: Support the DIMM lightly with your fingers when pressing the retaining clips. The DIMM might get damaged when it flips out with extra force.

5 Expansion slots

In the future, you may need to install expansion cards. The following shows the slots and the expansion cards that they support.

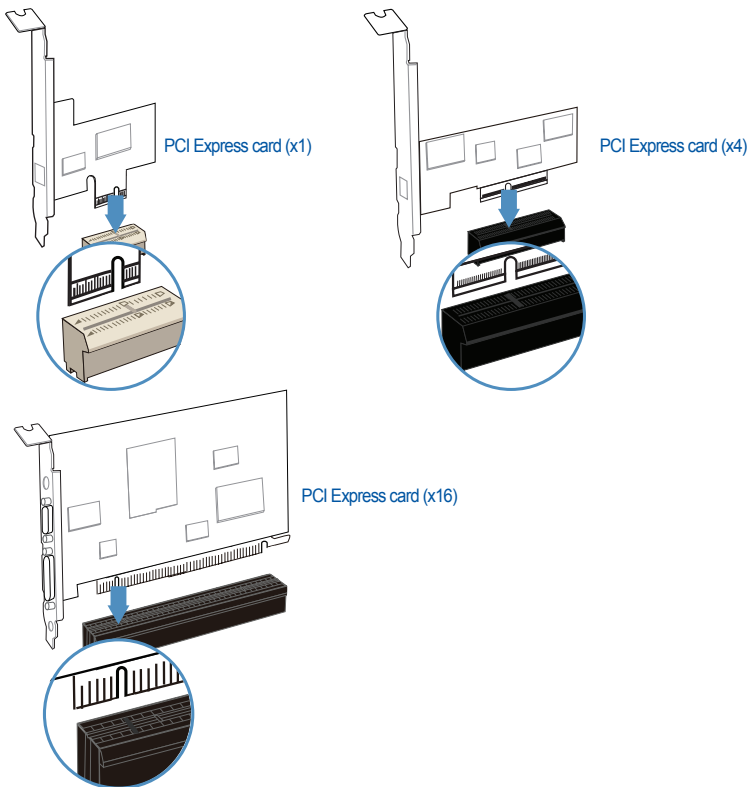

Installing an expansion card

IMPORTANT: Make sure to unplug the power cord before adding or removing expansion cards. Failure to do so may cause you physical injury and damage motherboard components.

To install an expansion card:

1. Before installing the expansion card, read the documentation that came with it and make the necessary hardware settings for the card.
2. Remove the system unit cover (if your motherboard is installed in a chassis).
3. Remove the bracket opposite the slot that you intend to use.
4. Align the card connector with the slot and press firmly until the card is completely seated on the slot.
5. Secure the card to the chassis with the screw you removed earlier.
6. Replace the system cover.

6 Selectors

Clear RTC RAM (CMOS)

This selector allows you to clear the Real Time Clock (RTC) RAM in CMOS. You can clear the CMOS memory of date, time, system setup parameters, and passwords by erasing the CMOS RTC RAM data.

IMPORTANT: Except when using this function, do not remove the jumper cap from the default position or else there may be a system boot failure!

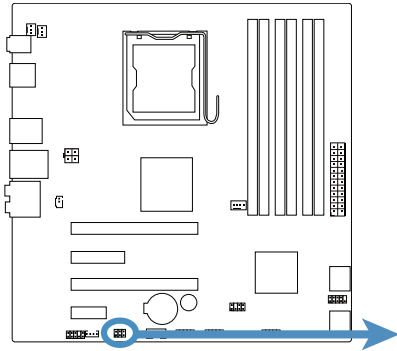

- To erase the CMOS RTC RAM user settings:**
1. Turn OFF the computer and unplug the power cord.
 2. Move the cap to clear for 5 to 10 secs, then move the cap back to default.
 3. Plug the power cord and the computer will turn on automatically.
 4. During the boot process, enter BIOS setup to re-enter user settings.

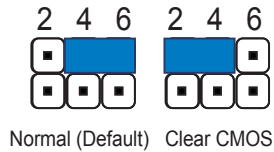

Clear password

This selector allows you to clear the password in CMOS.

IMPORTANT: Except when using this function, do not remove the jumper cap from the default position or else there may be a system boot failure!

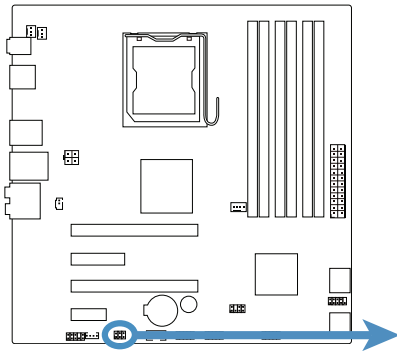

- To clear the password:**
1. Turn OFF the computer.
 2. Move the cap to **Clear**.
 3. Turn ON the computer to POST screen.
 4. Turn OFF the computer.
 5. Move the cap back to **Default**.
 6. Enter BIOS setup to verify or configure new settings.

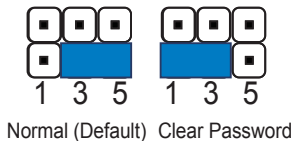

7 Connectors

ATX power connectors (24-pin ATXPOWER and 4-pin ATX_CPU)

These connectors are for ATX power supply plugs. The power supply plugs are designed to fit these connectors in only one orientation. Find the proper orientation and push down firmly until the connectors completely fit.

NOTE: Do not forget to connect the 4-pin ATX +12 V power plug; otherwise, the system will not boot.

NOTE: Use of a PSU with a higher power output is recommended when configuring a system with more power-consuming devices. The system may become unstable or may not boot up if the power is inadequate.

NOTE: Make sure that your power supply unit (PSU) can provide at least the minimum power required by your system.

NOTE: If you intent to use a PSU with 20-pin and 4-pin power plugs, make sure that the 20-pin power plug can provide at least 15A on +12V and that the PSU has a minimum power rating of 350 W. The system may become unstable or may not boot up if the power is inadequate.

NOTE: You must install a PSU with a higher power rating if you intend to install additional devices.

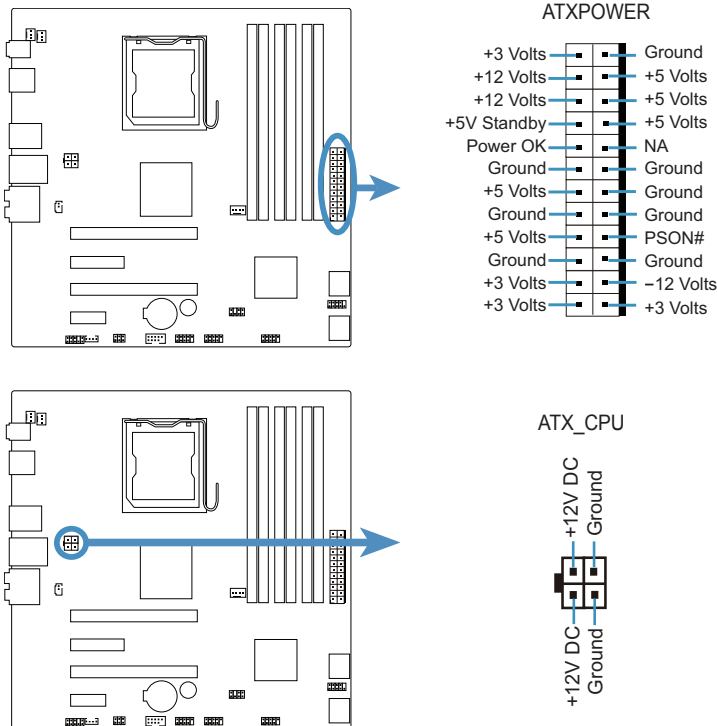

7 Connectors

Chassis/ System fan connector

Connect the fan cables to the fan connectors on the motherboard, making sure that the black wire of each cable matches the ground pin of the connector.

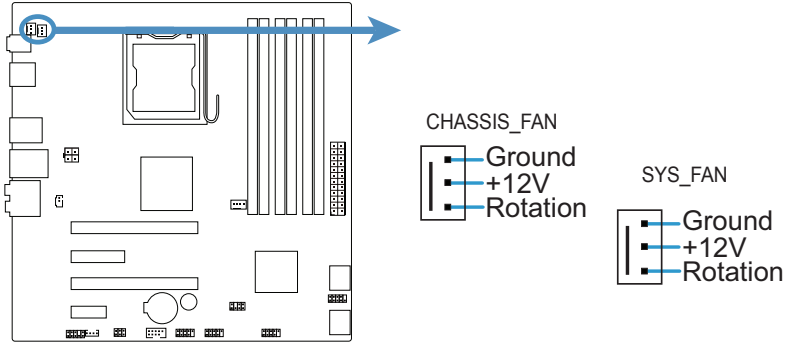

Audio line in connector (optional)

This connector allows you to receive stereo audio input from sound sources such as an optical disc drive, a TV tuner, or a specialized audio/sound-processing card.

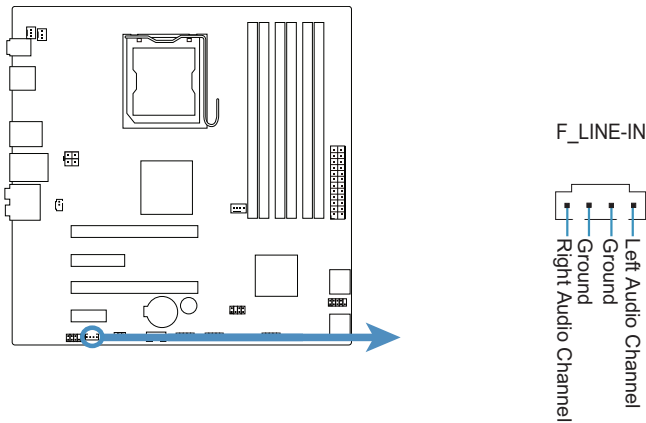

7 Connectors

Serial ATA connectors

These connectors are for the Serial ATA signal cables for Serial ATA devices.

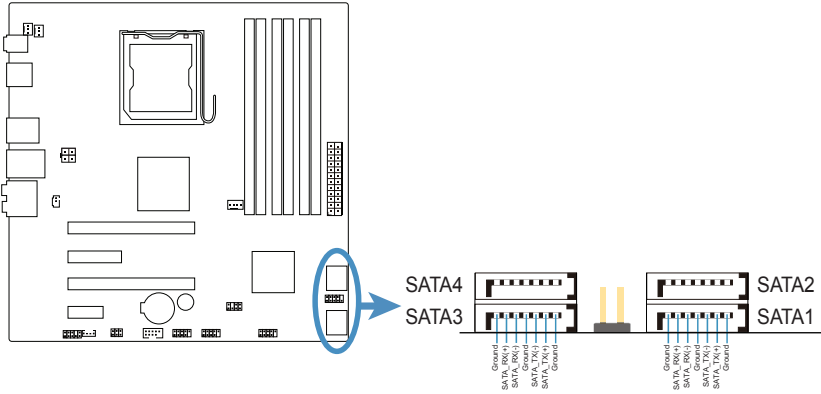

USB connectors

These connectors are for USB 2.0 ports. Connect a USB module cable to any of these connectors, then install the module to a slot opening at the back of the system chassis. These USB connectors comply with USB 2.0 specification that supports up to 480 Mbps connection speed.

WARNING: Never connect a 1394 cable to the USB connectors. Doing so will damage the motherboard!

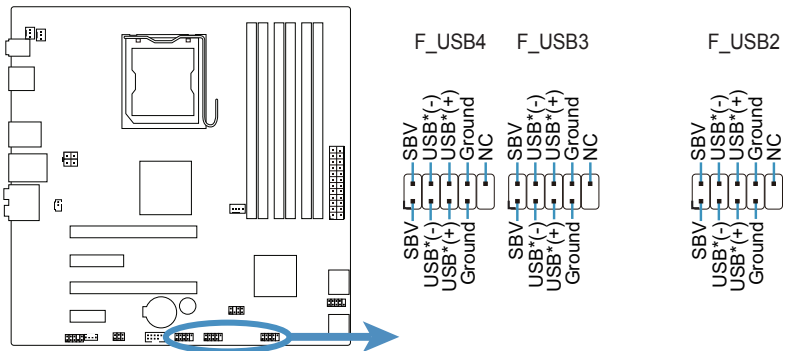

7 Connectors

IEEE 1394 port connector

This connector is for a 1394 port. Connect the 1394 cable from the system front panel to this connector.

WARNING: Never connect a USB cable to the IEEE 1394 connector. Doing so will damage the motherboard!

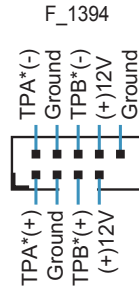
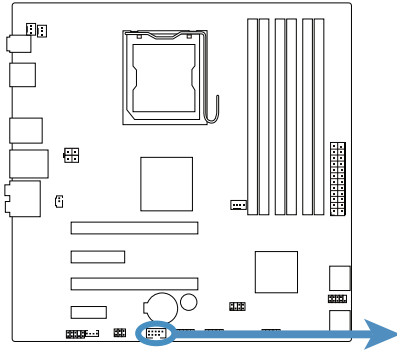

Digital Audio connector

This connector is for the S/PDIF audio module to allow digital sound output. Connect one end of the S/PDIF audio cable to this connector and the other end to the S/PDIF module (may require separate purchase).

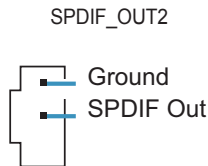
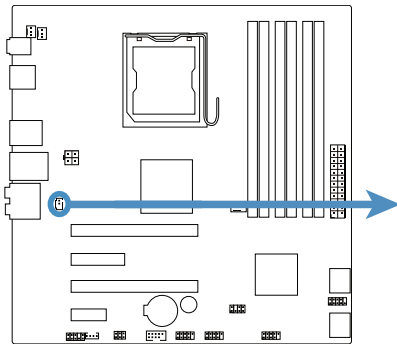

7 Connectors

Front panel audio connector

This connector is for a chassis-mounted front panel audio I/O module that supports HD Audio.

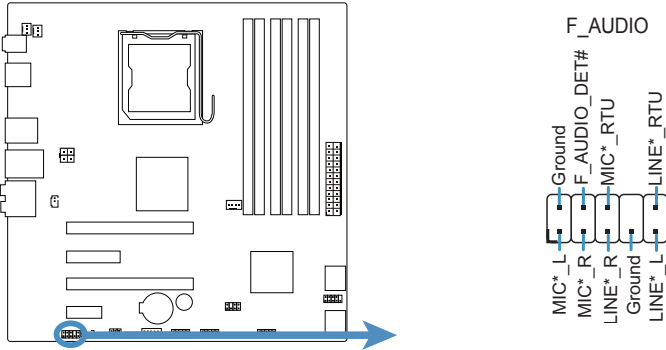

NOTE: It is recommended that you connect a high-definition front panel audio module to this connector to utilize this motherboard's high-definition audio capability.

ROM Recovery connector

This connector allows qualified technicians to reload firmware into the SPI boot flash in case there is problem with the data.

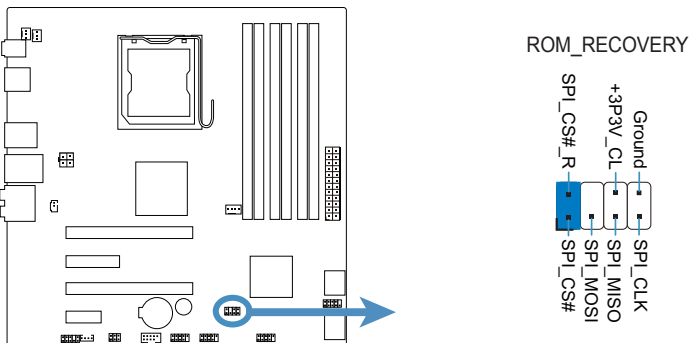

7 Connectors

System panel connector

These connectors support several chassis-mounted functions.

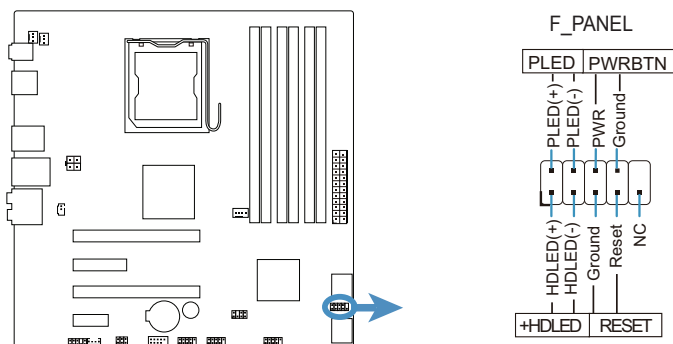

System power LED (2-pin PLED)

This 2-pin connector is for the system power LED. Connect the chassis power LED cable to this connector. The system power LED lights up when you turn on the system power.

Hard disk drive activity LED (2-pin +HDLED)

This 2-pin connector is for the HDD Activity LED. Connect the HDD Activity LED cable to this connector. The IDE LED lights up or flashes when data is read from or written to the HDD.

ATX power button/soft-off button (2-pin PWRBTN)

This connector is for the system power button. Pressing the power button turns the system on or puts the system in sleep or soft-off mode depending on the BIOS settings. Pressing the power switch for more than four seconds while the system is ON turns the system OFF.

Reset button (2-pin RESET)

This 2-pin connector is for the chassis-mounted reset button for system reboot without turning off the system power.

8 BIOS Setup reference

BIOS setup program

Just when the computer first starts up (before entering your operating system), press and hold the key to enter the BIOS setup program. (Press <Ctrl+Alt+Delete> to restart if you missed the opportunity.)

NOTE: Default BIOS settings apply for most conditions to ensure optimum performance. If this system becomes unstable after changing any BIOS settings, load the default settings to ensure system compatibility and stability. Find the load default options under the Exit Menu.

IMPORTANT: The BIOS settings are subject to change without notice

Main

The Main menu items provide an overview of basic system information.

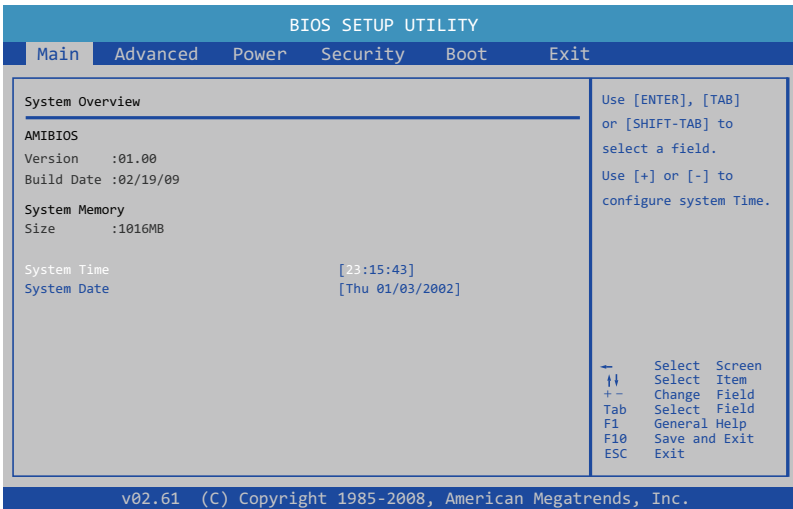

Note: The BIOS setup screens shown in this section are for reference purposes only, and may not exactly match what you see on your screen.

AMIBIOS

Displays the auto-detected BIOS information.

System Memory

Displays the auto-detected system memory information.

System Time [xx:xx:xx]

This item allows you to set the system time.

System Date [Day xx/xx/xxxx]

This item allows you to set the system date.

8 BIOS Setup reference

Advanced

The Advanced menu items provide advanced information and configuration options to allow enabling or disabling of motherboard chipset features.

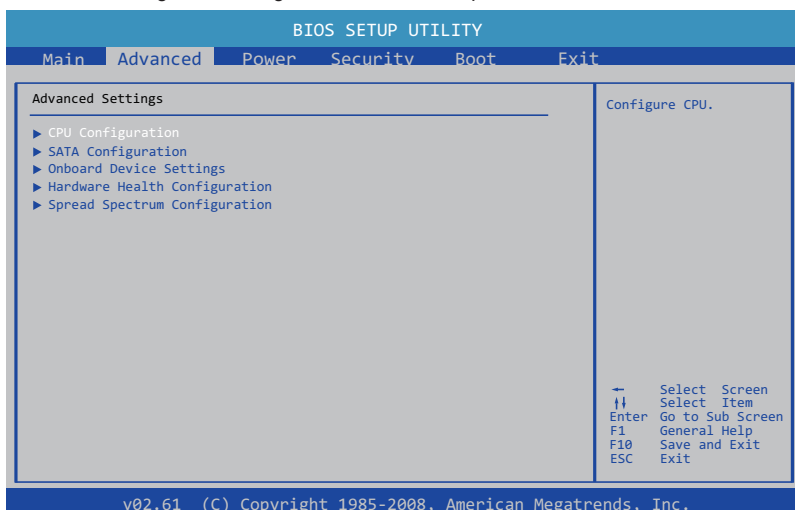

▶ CPU Configuration

The items in this menu show the CPU-related information that the BIOS automatically detects.

▶ SATA Configuration

The items in this menu allow you to view or change SATA device settings.

▶ Onboard Device Settings

The items in this menu allow you to view or change onboard device settings.

▶ Hardware Health Configuration

The items in this menu allow you to view or change hardware health settings such as voltages, cooling fan performance, temperatures, hard drive status. Actual items vary by system.

▶ Spread Spectrum Configuration

The items in this menu allow you to view or change spread spectrum configurations.

8 BIOS Setup reference

Power

The power menu items allow you to view or change system power management preferences.

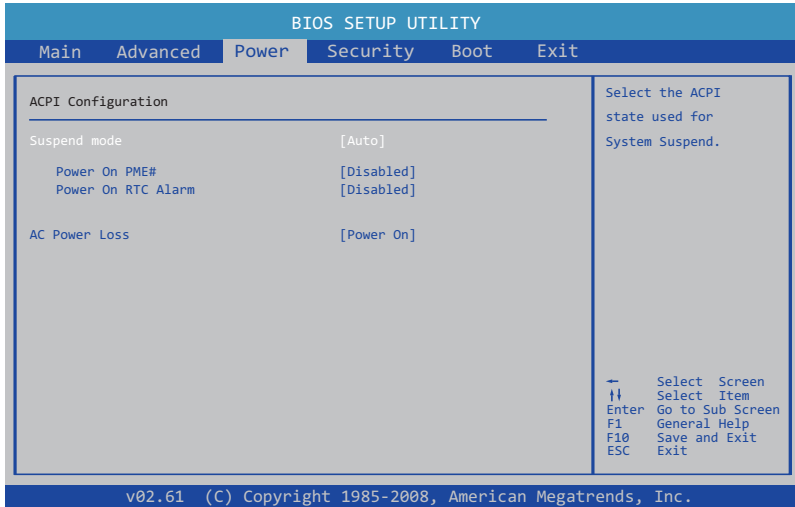

▶ ACPI Configuration

Suspend Mode

This item allows you to select the Advanced Configuration and Power Interface (ACPI) state to be used for system suspend.

Default: [Auto]

Power On By PME#

This item allows you to change the Power On By PME# setting.

Default: [Disabled] / Options: [Disabled] [Enabled]

Power On RTC Alarm

This item allows you to change the Power On RTC Alarm setting.

Default: [Disabled] / Options: [Disabled] [Enabled]

AC Power Loss

When set to [Power Off], the system goes into off state after an AC power loss. When set to [Power On], the system goes on after an AC power loss. When set to [Last State], the system goes into either off or on state, whatever the system state was before the AC power loss.

Default: [Power On]

8 BIOS Setup reference

Security

The security items allow you to view or change system security settings.

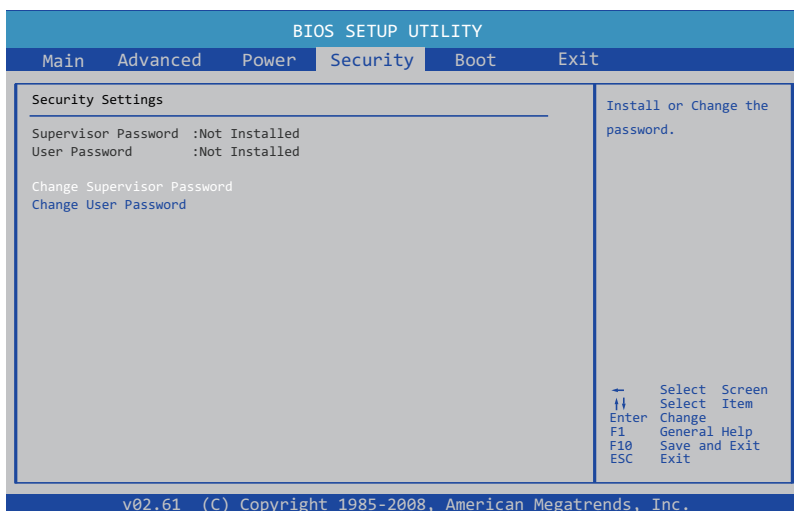

► Change Supervisor Password

Select this item to set or change the supervisor password. The **Supervisor Password** item on top of the screen shows the default **Not Installed**. After you set a password, this item shows **Installed**.

To set a Supervisor Password:

1. Select the **Change Supervisor Password** item and press <Enter>.
2. From the password box, type a password composed of at least six letters and/or numbers, then press <Enter>.
3. Confirm the password when prompted.

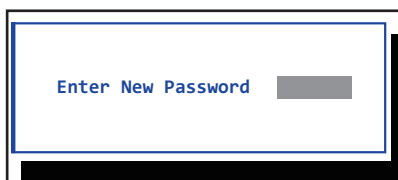

The message “Password Installed” appears after you successfully set your password. To change the supervisor password, follow the same steps as in setting a user password. To clear the supervisor password, select the **Change Supervisor Password** then press <Enter>. The message “Password Uninstalled” appears.

NOTE: If you forget your BIOS password, you can clear it by erasing the CMOS Real Time Clock (RTC) RAM. See your hardware documentation for information on how to erase the RTC RAM.

8 BIOS Setup reference

Security

After you have set a supervisor password, the other items appear to allow you to change other security settings.

▶ User Access Level

This item allows you to select the access restriction to the Setup items. Configuration options: [No Access] [View Only] [Limited] [Full Access]

[No Access] prevents user access to the Setup utility.

[View Only] allows access but does not allow change to any field.

[Limited] allows changes only to selected fields, such as Date and Time.

[Full Access] allows viewing and changing all the fields in the Setup utility.

▶ Change User Password

Select this item to set or change the user password. The **User Password** item on top of the screen shows the default **Not Installed**. After you set a password, this item shows Installed.

To set a User Password

1. Select the **Change User Password** item and press <Enter>.
2. On the password box that appears, type a password composed of at least six letters and/or numbers, then press <Enter>.
3. Confirm the password when prompted.

The message "Password Installed" appears after you set your password successfully. To change the user password, follow the same steps as in setting a user password.

Clear User Password

Select this item to clear the user password.

Password Check

When set to [Setup], BIOS checks for user password when accessing the Setup utility. When set to [Always], BIOS checks for user password both when accessing Setup and booting the system.

Default: [Setup] / Options: [Setup] [Always]

8 BIOS Setup reference

Boot

The Boot menu items allow you to view or change your boot device features.

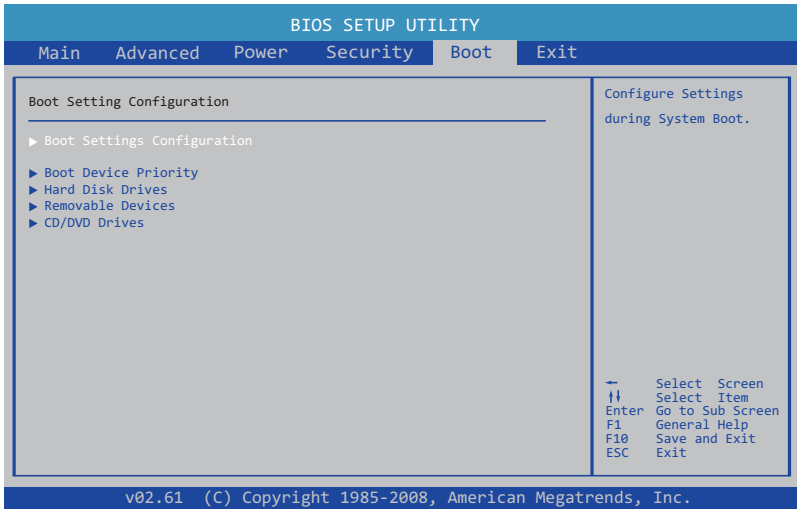

▶ Boot Settings Configuration

The items in this menu allow you to view or change the boot device settings.

▶ Boot Device Priority

The items in this menu allow you to view or change the priority of boot devices.

▶ Hard Disk Drives

The items in this menu allow you to view or change the hard disk devices settings.

▶ Removable Drives

The items in this menu allow you to view or change the removable devices settings.

▶ CD/DVD Drives

The items in this menu allow you to view or change the CD/DVD devices settings.

8 BIOS Setup reference

Exit

The Exit menu items allow you to load default values for BIOS items, and save or discard your changes to the BIOS items.

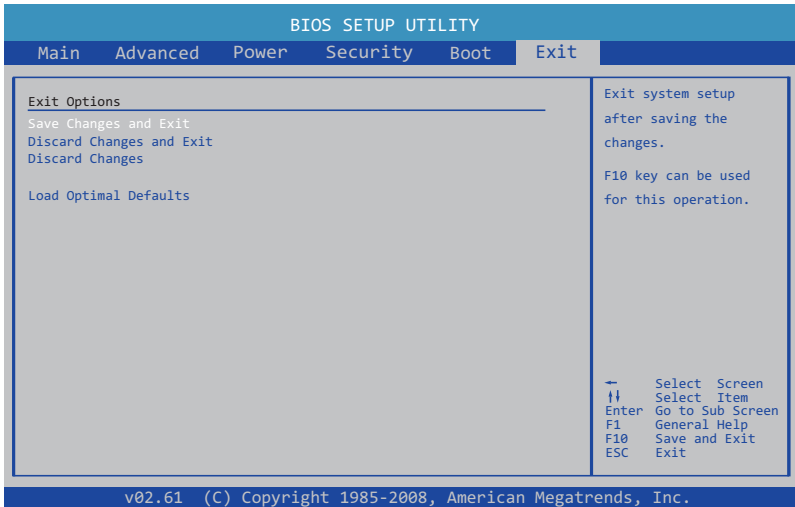

Pressing <Esc> does not immediately exit this menu. Select one of the options from this menu or <F10> from the legend bar to exit.

Save Changes and Exit

Once you are finished making your selections, choose this option from the Exit menu to ensure the values you selected are saved to the CMOS RAM. An onboard backup battery sustains the CMOS RAM so it stays on even when the PC is turned off. When you select this option, a confirmation window appears. Select **Ok** to save changes and exit.

NOTE: If you attempt to exit the Setup program without saving your changes, the program prompts you with a message asking if you want to save your changes before exiting. Press <Enter> to save the changes while exiting.

Discard Changes and Exit

Select this option only if you do not want to save the changes that you made to the Setup program. If you made changes to fields other than System Date, System Time, and Password, the BIOS asks for a confirmation before exiting.

Discard Changes

This option allows you to discard the selections you made and restore the previously saved values. After selecting this option, a confirmation appears. Select **Ok** to discard any changes and load the previously saved values.

8 BIOS Setup reference

Exit

Load Optimal Default

This option allows you to load the optimal default values for each of the parameters on the Setup items. When you select this option, a confirmation window appears. Select **Yes** to load the optimal default values. Select **Save Changes and Exit** or make other changes before saving.