

## **FCC Information and Copyright**

This equipment has been tested and found to comply with the limits of a Class B digital device, pursuant to Part 15 of the FCC Rules. These limits are designed to provide reasonable protection against harmful interference in a residential installation. This equipment generates, uses, and can radiate radio frequency energy and, if not installed and used in accordance with the instructions, may cause harmful interference to radio communications. There is no guarantee that interference will not occur in a particular installation.

The vendor makes no representations or warranties with respect to the contents here and specially disclaims any implied warranties of merchantability or fitness for any purpose. Further the vendor reserves the right to revise this publication and to make changes to the contents here without obligation to notify any party beforehand.

Duplication of this publication, in part or in whole, is not allowed without first obtaining the vendor's approval in writing.

The content of this user's manual is subject to be changed without notice and we will not be responsible for any mistakes found in this user's manual. All the brand and product names are trademarks of their respective companies.

---

---

## Table of Contents

---

---

<b>Chapter 1: Introduction</b> .....	<b>1</b>
<b>1.1 Before You Start</b> .....	1
<b>1.2 Package Checklist</b> .....	1
<b>1.3 Motherboard Features</b> .....	2
<b>1.4 Rear Panel Connectors</b> .....	3
<b>1.5 Motherboard Layout</b> .....	4
<b>Chapter 2: Hardware Installation</b> .....	<b>5</b>
<b>2.1 Installing Central Processing Unit (CPU)</b> .....	5
<b>2.2 FAN Headers</b> .....	7
<b>2.3 Installing System Memory</b> .....	8
<b>2.4 Connectors and Slots</b> .....	10
<b>Chapter 3: Headers &amp; Jumpers Setup</b> .....	<b>13</b>
<b>3.1 How to Setup Jumpers</b> .....	13
<b>3.2 Detail Settings</b> .....	13
<b>Chapter 4: CrossFire Function</b> .....	<b>21</b>
<b>4.1 Requirements</b> .....	21
<b>4.2 Installing CrossFire-Ready Graphics Cards</b> .....	21
<b>Chapter 5: RAID Functions</b> .....	<b>23</b>
<b>5.1 Operation System</b> .....	23
<b>5.2 Raid Arrays</b> .....	23
<b>5.3 How RAID Works</b> .....	23
<b>Chapter 6: T-Power BIOS &amp; Software</b> .....	<b>27</b>
<b>6.1 T-Power BIOS</b> .....	27
<b>6.2 T-Power Software</b> .....	35
<b>Chapter 7: Useful Help</b> .....	<b>45</b>
<b>7.1 Driver Installation Note</b> .....	45
<b>7.2 Extra Information</b> .....	46
<b>7.3 AMI BIOS Beep Code</b> .....	47
<b>7.4 AMI BIOS Post Code</b> .....	48
<b>7.5 Troubleshooting</b> .....	50
<b>Appendencies: SPEC In Other Language</b> .....	<b>52</b>
<b>German</b> .....	52
<b>France</b> .....	54
<b>Italian</b> .....	56
<b>Spanish</b> .....	58
<b>Portuguese</b> .....	60
<b>Polish</b> .....	62
<b>Russian</b> .....	64
<b>Arabic</b> .....	66
<b>Japanese</b> .....	68

---

---









## **CHAPTER 1: INTRODUCTION**

### **1.1 BEFORE YOU START**

Thank you for choosing our product. Before you start installing the motherboard, please make sure you follow the instructions below:

- Prepare a dry and stable working environment with sufficient lighting.
- Always disconnect the computer from power outlet before operation.
- Before you take the motherboard out from anti-static bag, ground yourself properly by touching any safely grounded appliance, or use grounded wrist strap to remove the static charge.
- Avoid touching the components on motherboard or the rear side of the board unless necessary. Hold the board on the edge, do not try to bend or flex the board.
- Do not leave any unfastened small parts inside the case after installation. Loose parts will cause short circuits which may damage the equipment.
- Keep the computer from dangerous area, such as heat source, humid air and water.

### **1.2 PACKAGE CHECKLIST**

-  HDD Cable X 1
-  Serial ATA Cable X 6
-  Serial ATA Power Cable X 6
-  Rear I/O Panel for ATX Case X 1
-  User's Manual X 1
-  Fully Setup Driver CD X 1
-  FDD Cable X 1 (optional)
-  USB 2.0 Cable X1 (optional)
-  S/PDIF out Cable X 1 (optional)

**Note:** The package contents may differ by area or your motherboard version.

### 1.3 MOTHERBOARD FEATURES

SPEC		
CPU	LGA 775 Intel Core2Duo / Core2Quad / Pentium Dual-Core / Celeron Dual-Core / Celeron 4xx processor	Supports Execute Disable Bit / Enhanced Intel SpeedStep® / Intel Architecture-64 / Extended Memory 64 Technology / Virtualization Technology
FSB	Support 800 / 1066 / 1333 / 1600 MHz	
Chipset	Intel P45 Intel ICH10R	
Super I/O	Fintek F71887F Provides the most commonly used legacy Super I/O functionality. Low Pin Count Interface	Environment Control initiatives, Hardware Monitor Controller Fan Speed Controller ITE's "Smart Guardian" function
Main Memory	DIMM Slots x 4 Each DIMM supports 256MB / 512MB / 1GB / 2GB DDR2 Max Memory Capacity 8GB	Dual Channel Mode DDR2 memory module Supports DDR2 1066 / 800 / 667 Registered DIMM and ECC DIMM is not supported
IDE	Marvell 88SE6121	Ultra DMA 33 / 66 / 100 / 133 Bus Master Mode supports PIO Mode 0~4
SATA II	ICH10R	Data transfer rates up to 3 Gb/s. SATA Version 2.0 specification compliant. RAID 0 / 1 / 5 / 1+0 support
eSATA	Marvell 88SE6121	Data transfer rates up to 3 Gb/s. SATA Version 2.0 specification compliant. Port-Multiplier/RAID 0,1 support
LAN	Realtek RTL 8111C	10 / 100 Mb/s / 1Gb/s auto negotiation Half / Full duplex capability
Sound Codec	ALC888S	7.1 channels audio out High Definition Audio
Slots	PCI slot x2 PCI Express Gen2 x16 slot (x16/x8) x1 PCI Express Gen2 x16 slot (x8) x1 PCI Express x1 slot x2	Supports PCI expansion cards Supports PCI-E Gen2 x16 expansion cards Supports PCI-E Gen2 x16 expansion cards Supports PCI-E x1 expansion cards
On Board Connector	Floppy connector x1 Serial port Connector x1 IDE Connector x1 SATA Connector x6 Front Panel Connector x1	Each connector supports 2 Floppy drives Connects to RS-232 Port Each connector supports 2 IDE device Each connector supports 1 SATA devices Supports front panel facilities

SPEC			
	Front Audio Connector	x1	Supports front panel audio function
	CD-in Connector	x1	Supports CD audio-in function
	S/PDIF out connector	x2	Supports digital audio out function
	S/PDIF in connector	x1	Supports digital audio-in function
	CPU Fan header	x1	CPU Fan power supply (with Smart Fan function)
	System Fan header	x2	System Fan Power supply
	Clear CMOS header	x1	Restore CMOS data to factory default
	USB connector	x3	Each connector supports 2 front panel USB ports
	Power Connector (24pin)	x1	Connects to Power supply
	Power Connector (8pin)	x1	Connects to Power supply
	Power Connector (4pin)	x1	Connects to Power supply
Back Panel I/O	PS/2 Keyboard	x1	Connects to PS/2 Keyboard
	PS/2 Mouse	x1	Connects to PS/2 Mouse
	LAN port	x1	Connect to RJ-45 ethernet cable
	USB Port	x6	Connect to USB devices
	Audio Jack	x6	Provide Audio-In/Out and microphone connection
	eSATA Port	x2	Connect to SATA devices
Board Size	244 (W) x 305 (L) mm		ATX
OS Support	Windows 2000 / XP / VISTA		Biostar Reserves the right to add or remove support for any OS with or without notice

### 1.4 REAR PANEL CONNECTORS

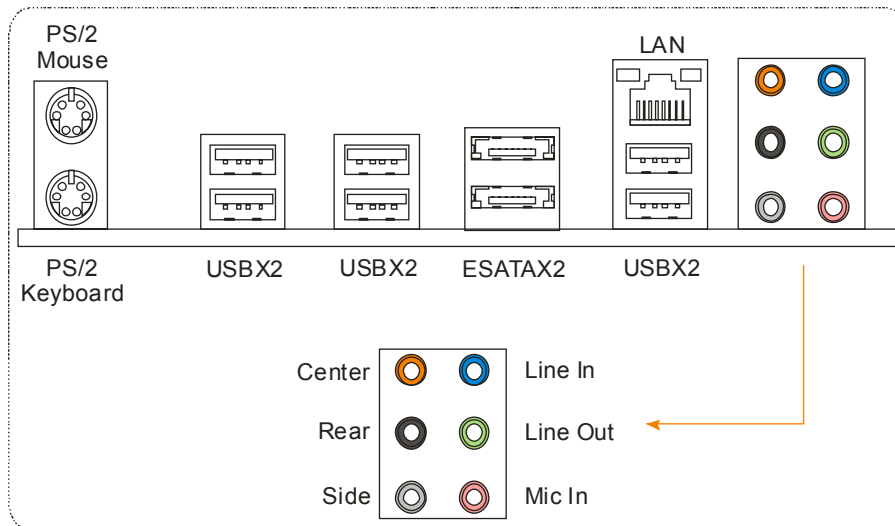

## 1.5 MOTHERBOARD LAYOUT

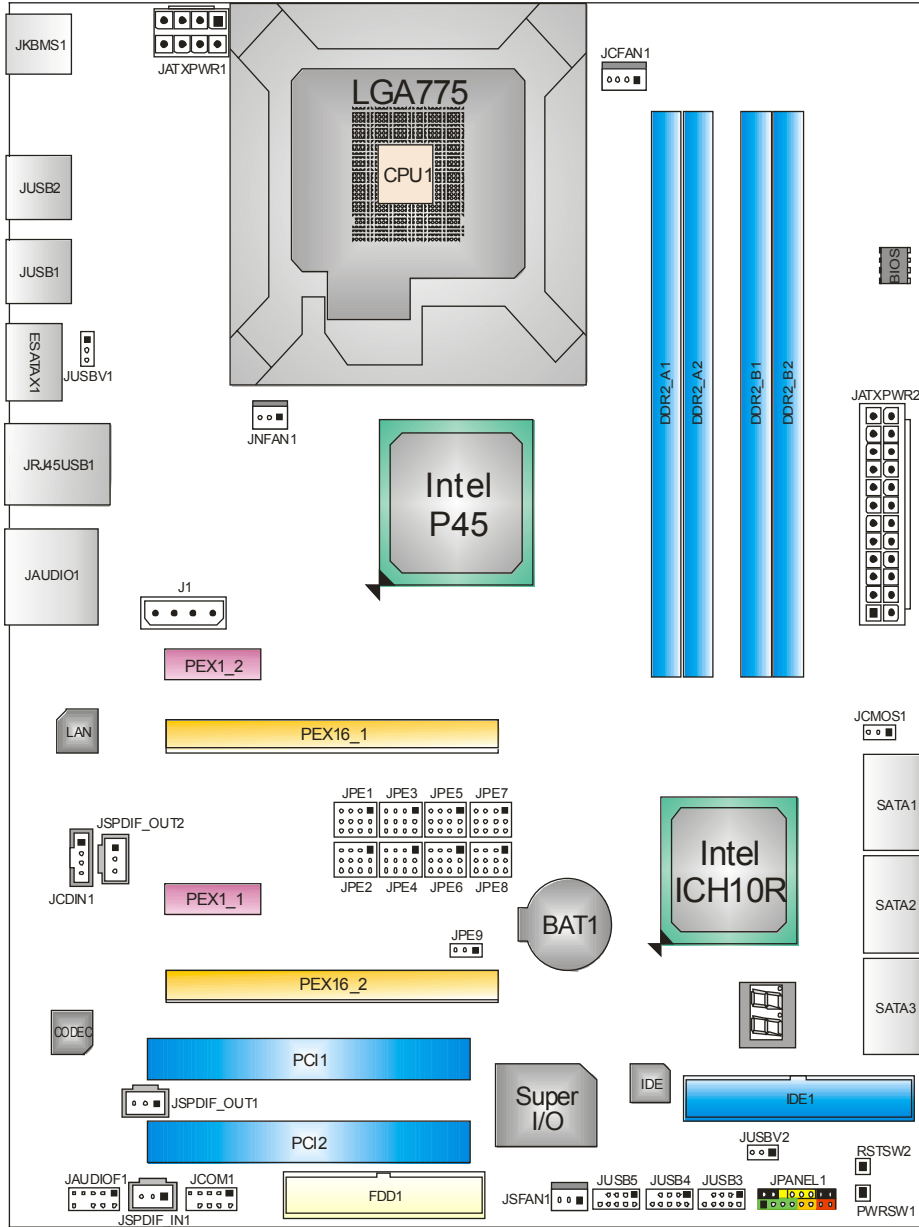

**Note:** ■ represents the 1<sup>st</sup> pin.

## CHAPTER 2: HARDWARE INSTALLATION

### 2.1 INSTALLING CENTRAL PROCESSING UNIT (CPU)

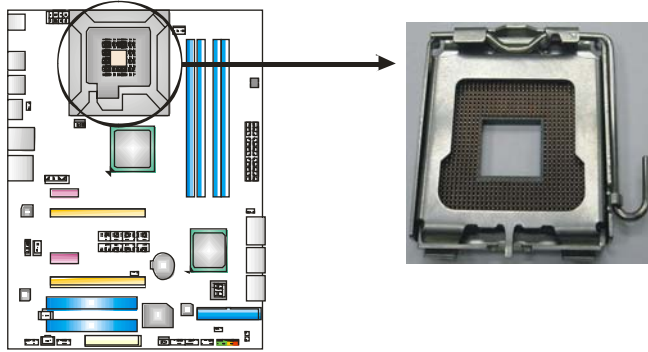

*Special Notice:*

Remove Pin Cap before installation, and make good preservation for future use. When the CPU is removed, cover the Pin Cap on the empty socket to ensure pin legs won't be damaged.

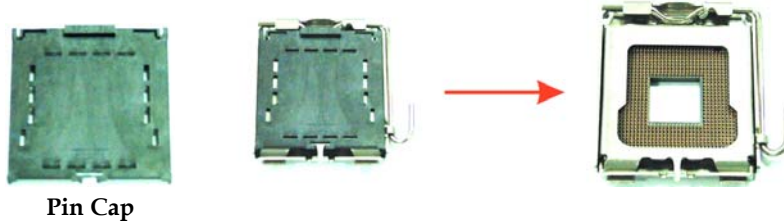

**Step 1:** Pull the socket locking lever out from the socket and then raise the lever up to a 90-degree angle.

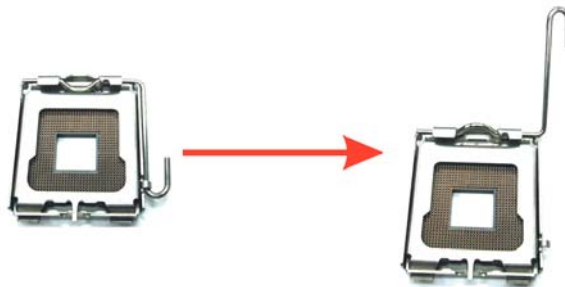

## Motherboard Manual

---

**Step 2:** Look for the triangular cut edge on socket, and the golden dot on CPU should point forwards this triangular cut edge. The CPU will fit only in the correct orientation.

*Step 2-1:*

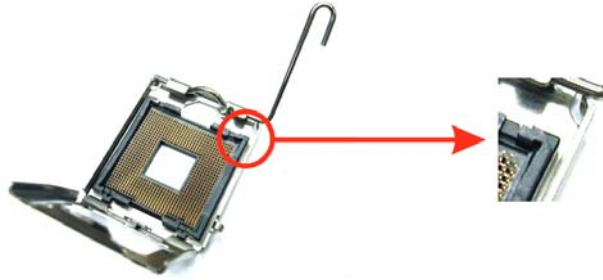

*Step 2-2:*

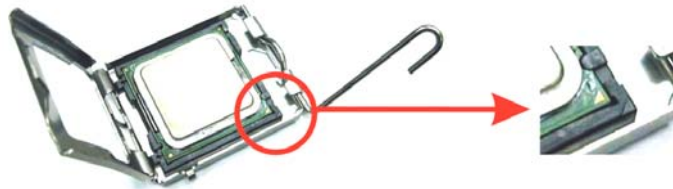

**Step 3:** Hold the CPU down firmly, and then lower the lever to locked position to complete the installation.



**Step 4:** Put the CPU Fan and heatsink assembly on the CPU and buckle it on the retention frame. Connect the CPU FAN power cable into the JCFAN1. This completes the installation.



## 2.2 FAN HEADERS

These fan headers support cooling-fans built in the computer. The fan cable and connector may be different according to the fan manufacturer. Connect the fan cable to the connector while matching the black wire to pin#1.

### JCFAN1: CPU Fan Header

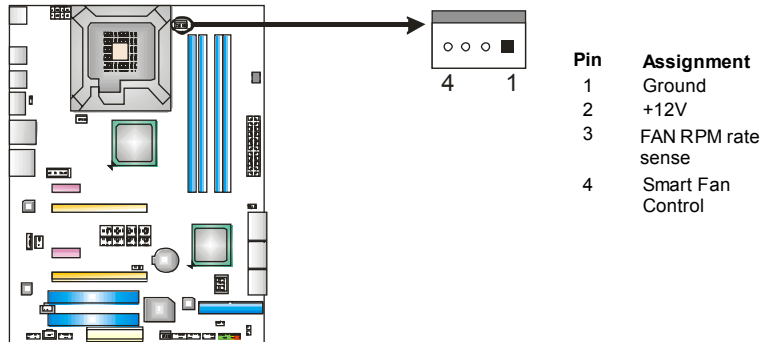

### JNFAN1: NorthBridge Fan Header

### JSFAN1: System Fan Header

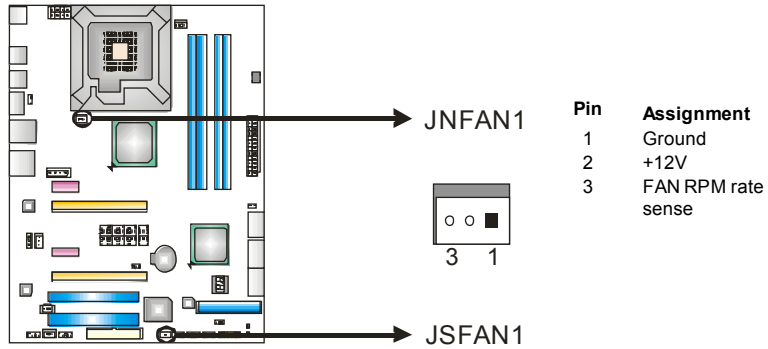

**Note:**

The JNFAN1/JSFAN1 support 3-pin head connectors, and the JCFAN1 supports 4-pin head connector. When connecting with wires onto connectors, please note that the red wire is the positive and should be connected to pin#2, and the black wire is Ground and should be connected to GND.

## 2.3 INSTALLING SYSTEM MEMORY

### A. Memory Modules

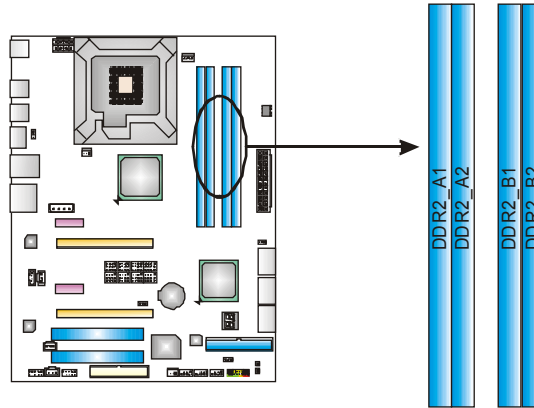

1. Unlock a DIMM slot by pressing the retaining clips outward. Align a DIMM on the slot such that the notch on the DIMM matches the break on the Slot.

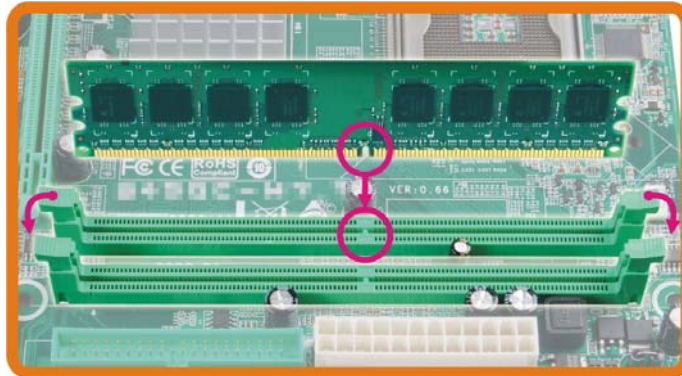

2. Insert the DIMM vertically and firmly into the slot until the retaining chip snap back in place and the DIMM is properly seated.

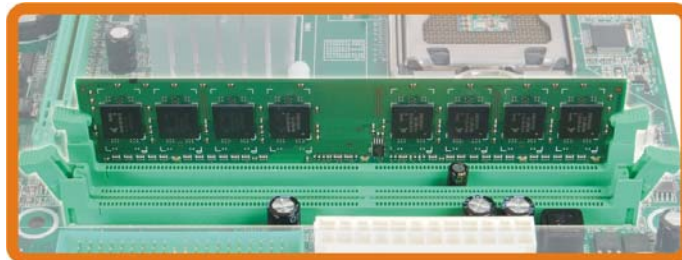

### B. Memory Capacity

DIMM Socket Location	DDR2 Module	Total Memory Size
DDR2_A1	256MB/512MB/1GB/2GB	Max is 8GB.
DDR2_A2	256MB/512MB/1GB/2GB	
DDR2_B1	256MB/512MB/1GB/2GB	
DDR2_B2	256MB/512MB/1GB/2GB	

### C. Dual Channel Memory installation

To trigger the Dual Channel function of the motherboard, the memory module must meet the following requirements:

Install memory module of the same density in pairs, shown in the following table.

Dual Channel Status	DDR2_A1	DDR2_A2	DDR2_B1	DDR2_B2
Enabled	O	X	O	X
Enabled	X	O	X	O
Enabled	O	O	O	O

(O means memory installed, X means memory not installed.)

The DRAM bus width of the memory module must be the same (x8 or x16)

## 2.4 CONNECTORS AND SLOTS

### FDD1: Floppy Disk Connector

The motherboard provides a standard floppy disk connector that supports 360K, 720K, 1.2M, 1.44M and 2.88M floppy disk types. This connector supports the provided floppy drive ribbon cables.

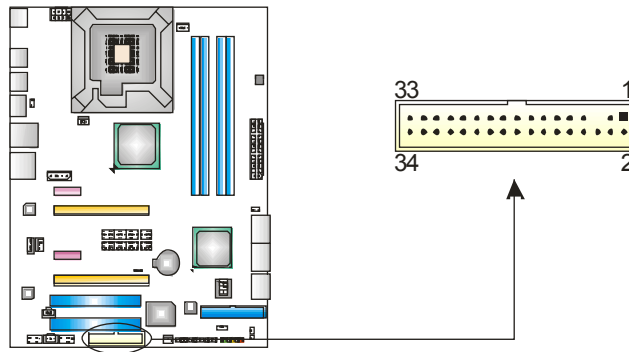

### IDE1: IDE/ATAPI Connector

The motherboard has a 32-bit Enhanced PCI IDE Controller that provides PIO Mode 0~4, Bus Master, and Ultra DMA 33/66/100/133 functionality.

The IDE connector can connect a master and a slave drive, so you can connect up to two devices.

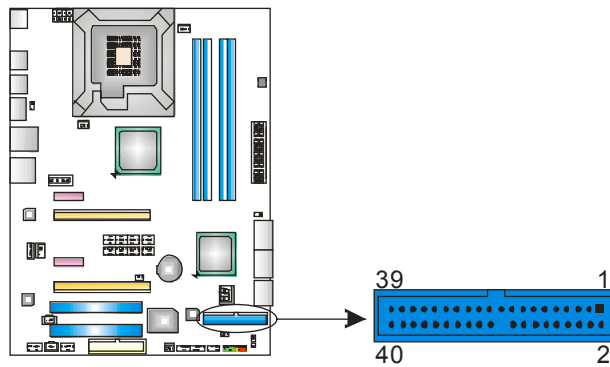

### SATA1~SATA3: Serial ATA Connectors

The motherboard has a PCI to SATA Controller with 6 channels SATA interface, it satisfies the SATA 2.0 spec and with transfer rate of 3.0Gb/s.

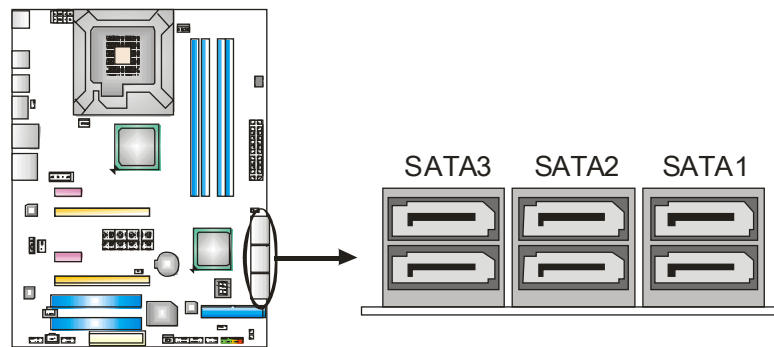

### PCI1/PCI2: Peripheral Component Interconnect Slots

This motherboard is equipped with 2 standard PCI slots. PCI stands for Peripheral Component Interconnect, and it is a bus standard for expansion cards. This PCI slot is designated as 32 bits.

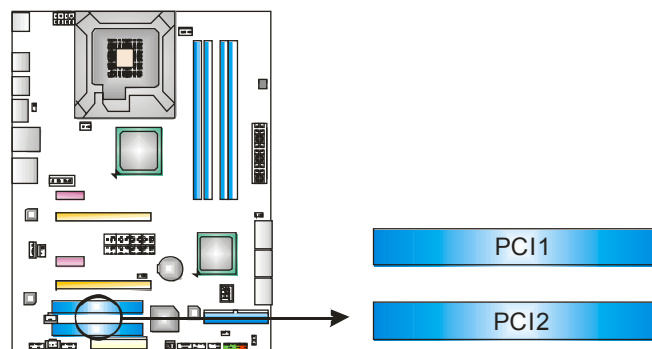

**PEX16\_1: PCI-Express Gen2 x16(x16/CrossFire x8 Speed) Slot**

- PCI-Express 2.0 compliant.
- Maximum theoretical realized bandwidth of 8GB/s(4GB/s CrossFire) simultaneously per direction, for an aggregate of 16GB/s(8GB/s CrossFire) totally.
- PEX16\_1 slot is reserved for graphics or video cards. The design of this motherboard supports dual PCI-Express graphics cards using CrossFire technology with multiple displays. When using CrossFire, this slot is master and runs with x8 speed.
- To configure for CrossFire, please refer to the instructions of configuring JPE1~JPE9.

**PEX16\_2: PCI-Express Gen2 x16(NC/CrossFire x8 Speed) Slot**

- PCI-Express 2.0 compliant.
- Maximum theoretical realized bandwidth of 4GB/s simultaneously per direction, for an aggregate of 8GB/s totally.
- PEX16\_2 slot is reserved for graphics or video cards. The design of this motherboard supports dual PCI-Express graphics cards using CrossFire technology with multiple displays. This slot is slave when using CrossFire. If PEX16\_1 is set to x16 speed, then PEX16\_2 would not be functional.

**PEX1\_1/PEX1\_2: PCI-Express x1 Slots**

- PCI-Express 1.0a compliant.
- Data transfer bandwidth up to 250MB/s per direction; 500MB/s in total.
- PCI-Express supports a raw bit-rate of 2.5Gb/s on the data pins.
- 2X bandwidth over the traditional PCI architecture.

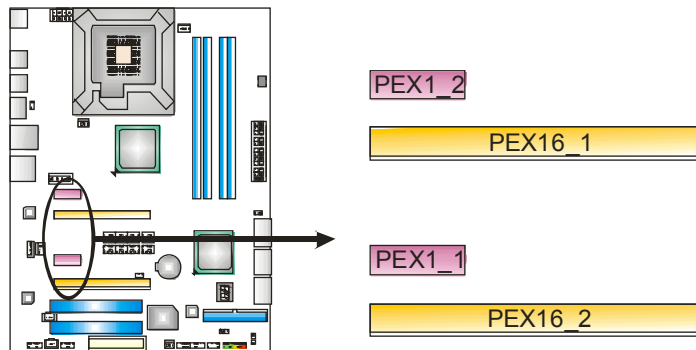

## CHAPTER 3: HEADERS & JUMPERS SETUP

### 3.1 HOW TO SETUP JUMPERS

The illustration shows how to set up jumpers. When the jumper cap is placed on pins, the jumper is “close”, if not, that means the jumper is “open”.



### 3.2 DETAIL SETTINGS

#### JPANEL1: Front Panel Header

This 16-pin connector includes Power-on, Reset, HDD LED, Power LED, and speaker connection. It allows user to connect the PC case’s front panel switch functions.

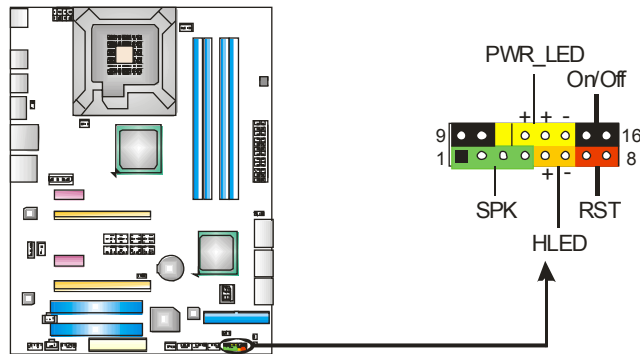

Pin	Assignment	Function	Pin	Assignment	Function
1	+5V	Speaker Connector	9	N/A	N/A
2	N/A		10	N/A	N/A
3	N/A		11	N/A	N/A
4	Speaker	Hard drive LED	12	Power LED (+)	Power LED
5	HDD LED (+)		13	Power LED (+)	
6	HDD LED (-)	Reset button	14	Power LED (-)	
7	Ground		15	Power button	
8	Reset control		16	Ground	

### JATXPWR2: ATX Power Source Connector

This connector allows user to connect 24-pin power connector on the ATX power supply.

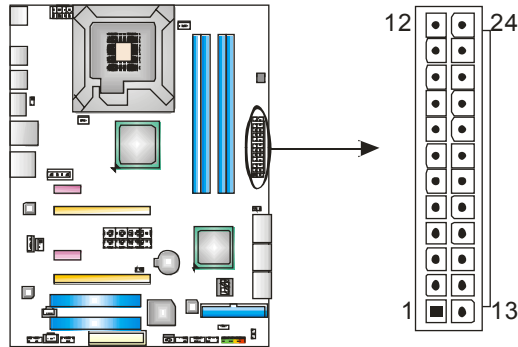

Pin	Assignment	Pin	Assignment
13	+3.3V	1	+3.3V
14	-12V	2	+3.3V
15	Ground	3	Ground
16	PS_ON	4	+5V
17	Ground	5	Ground
18	Ground	6	+5V
19	Ground	7	Ground
20	NC	8	PW_OK
21	+5V	9	Standby Voltage+5V
22	+5V	10	+12V
23	+5V	11	+12V
24	Ground	12	+3.3V

### JATXPWR1: ATX Power Source Connector

By connecting this connector, it will provide +12V to CPU power circuit.

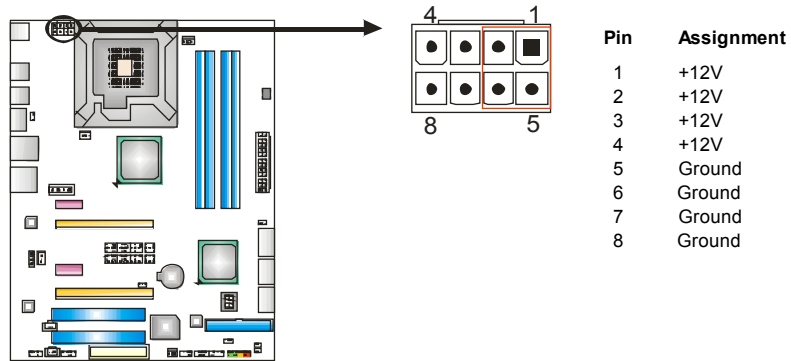

Pin	Assignment
1	+12V
2	+12V
3	+12V
4	+12V
5	Ground
6	Ground
7	Ground
8	Ground

**Note:**

Before power on the system, please make sure that both JATXPWR1 and JATXPWR2 connectors have been plugged-in.

**If the CPU power plug is 4-pin, please plug it into Pin 1-2-5-6 of JATXPWR1.**



**J1: Auxiliary Power for Graphics**

This connector is an auxiliary power connection for graphics cards. Exclusive power for the graphics card provides better graphics performance.

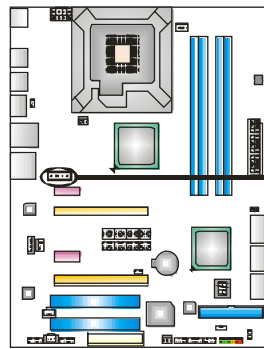

Pin	Assignment
1	+12V
2	Ground
3	Ground
4	VCC

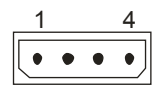

**JUSB3/JUSB4/JUSB5: Headers for USB 2.0 Ports at Front Panel**

This header allows user to connect additional USB cable on the PC front panel, and also can be connected with internal USB devices, like USB card reader.

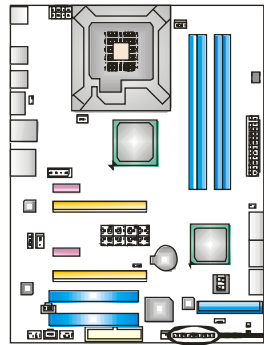

Pin	Assignment
1	+5V (fused)
2	+5V (fused)
3	USB-
4	USB-
5	USB+
6	USB+
7	Ground
8	Ground
9	Key
10	NC

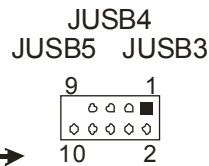

**JAUDIOF1: Front Panel Audio Header**

This header allows user to connect the front audio output cable with the PC front panel. This header allows only HD audio front panel connector; AC'97 connector is not acceptable.

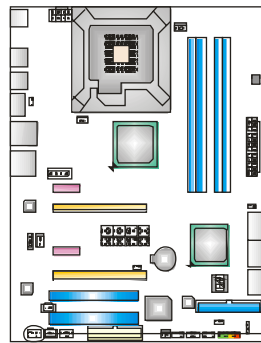

Pin	Assignment
1	Mic Left in
2	Ground
3	Mic Right in
4	GPIO
5	Right line in
6	Jack Sense
7	Front Sense
8	Key
9	Left line in
10	Jack Sense

**JCDIN1: CD-ROM Audio-in Connector**

This connector allows user to connect the audio source from the variety devices, like CD-ROM, DVD-ROM, PCI sound card, PCI TV turner card etc..

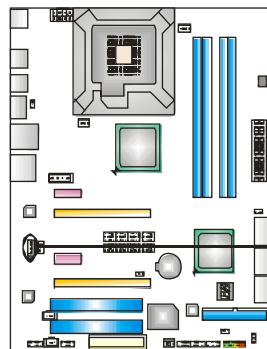

Pin	Assignment
1	Left Channel Input
2	Ground
3	Ground
4	Right Channel Input

**JSPDIF\_OUT1/JSPDIF\_OUT2: Digital Audio-out Connectors**

JSPDIF\_OUT1 is for connecting the PCI bracket SPDIF output, and JSPDIF\_OUT2 is for connecting to the HDMI audio of VGA card.

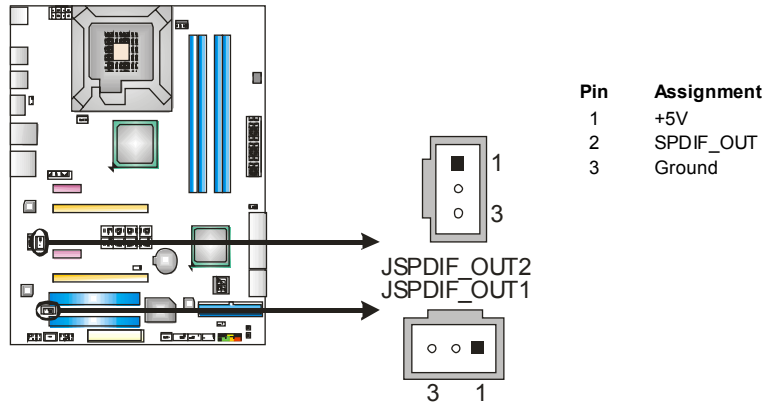

**JSPDIF\_IN1: Digital Audio-in Connector**

This connector allows user to connect the PCI bracket SPDIF input header.

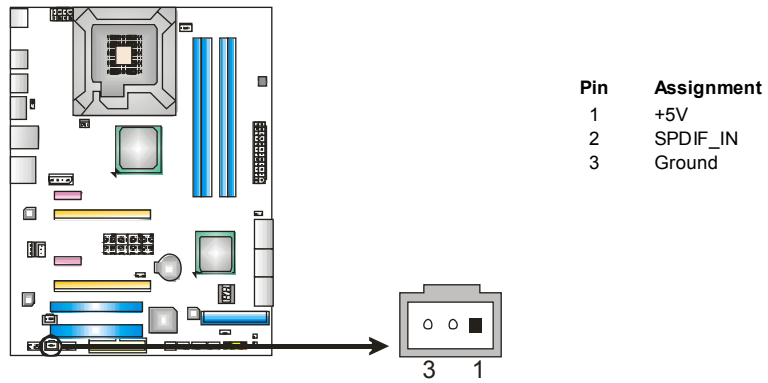

### JCOM1: Serial port Connector

The motherboard has a Serial Port Connector for connecting RS-232 Port.

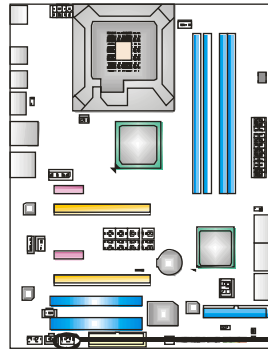

Pin	Assignment
1	Carrier detect
2	Received data
3	Transmitted data
4	Data terminal ready
5	Signal ground
6	Data set ready
7	Request to send
8	Clear to send
9	Ring indicator
10	Key

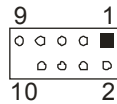

### JCMOS1: Clear CMOS Header

By placing the jumper on pin2-3, it allows user to restore the BIOS safe setting and the CMOS data, please carefully follow the procedures to avoid damaging the motherboard.

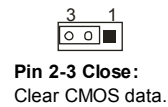
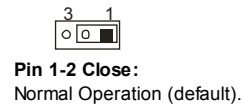
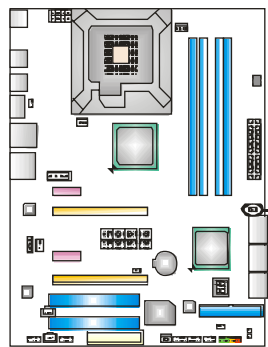

#### ※ Clear CMOS Procedures:

1. Remove AC power line.
2. Set the jumper to "Pin 2-3 close".
3. Wait for five seconds.
4. Set the jumper to "Pin 1-2 close".
5. Power on the AC.
6. Reset your desired password or clear the CMOS data.

### JUSBV1/JUSBV2: Power Source Headers for USB Ports

**Pin 1-2 Close:**

JUSBV1: +5V for USB ports at JUSB1/JUSB2/JRJ45USB1.

JUSBV2: +5V for USB ports at JUSB3/JUSB4/JUSB5.

**Pin 2-3 Close:**

JUSBV1: +5V STB for USB ports at JUSB1/JUSB2/ JRJ45USB1.

JUSBV2: +5V STB for USB ports at JUSB3/JUSB4/JUSB5.

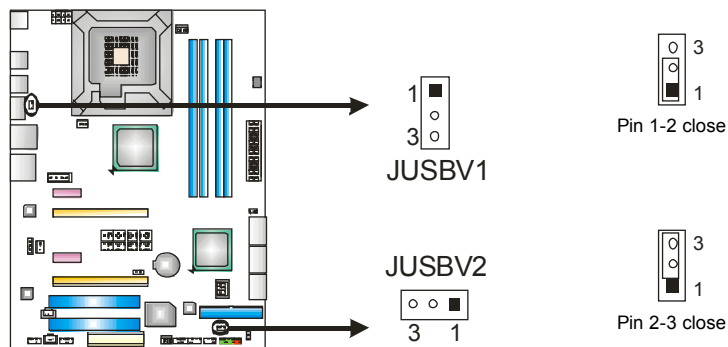

### On-Board Buttons

There are 2 on-board buttons.

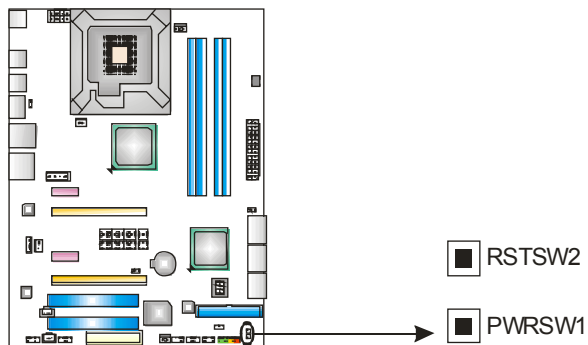

**PWRSW1:**

This is an on-board Power Switch button.

**RSTSW2:**

This is an on-board Reset button.

### BIOS POST Code/CPU Temperature Indicator

This indicator will show POST code while booting; after the booting sequence, it will show current CPU temperature. Please refer to Chapter 7.4 for all the BIOS POST codes.

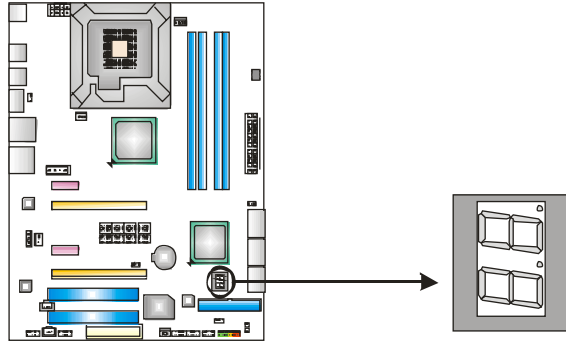

### JPE1~JPE9: CrossFire Switch Jumpers

The setting of these jumpers determines the operation mode of PEX16\_1 and PEX16\_2. If you want to use the CrossFire function, these jumpers should be set to Pin 2-3 close; and PEX16\_1 and PEX16\_2 will both run with x8 speed. If these jumpers are set to Pin 1-2 close, PEX16\_1 will run with x16 speed and PEX16\_2 will not be functional.

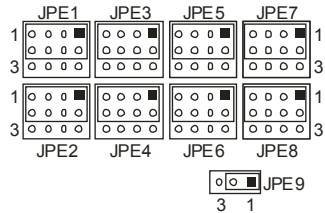
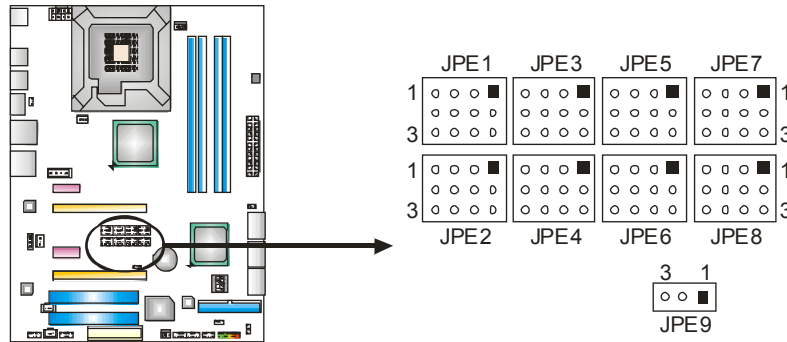

**Pin 1-2 Close**  
 Normal Operation  
 PEX16\_1: x16 Speed  
 PEX16\_2: Not Functional

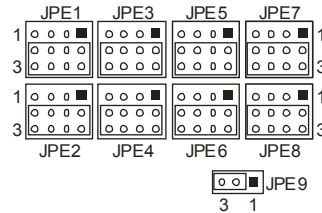

**Pin 2-3 Close:**  
 CrossFire Operation  
 PEX16\_1: x8 Speed  
 PEX16\_2: x8 Speed

## CHAPTER 4: CROSSFIRE FUNCTION

### 4.1 REQUIREMENTS

- Only Windows XP/Vista supports CrossFire (Dual Video) function.
- Two identical CrossFire-ready graphics cards that are ATI certified.
- The graphics card driver should support CrossFire technology.
- The power supply unit must provide at least the minimum power required by the system, or the system will be unstable. A power supply above 500W is recommended under CrossFire mode.

### 4.2 INSTALLING CROSSFIRE-READY GRAPHICS CARDS

**Step 1:** Power off the computer and set JPE1~JPE9 to Pin2-3 close.

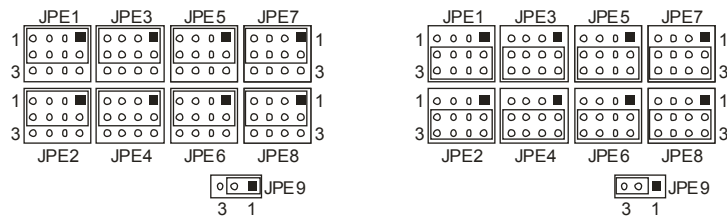
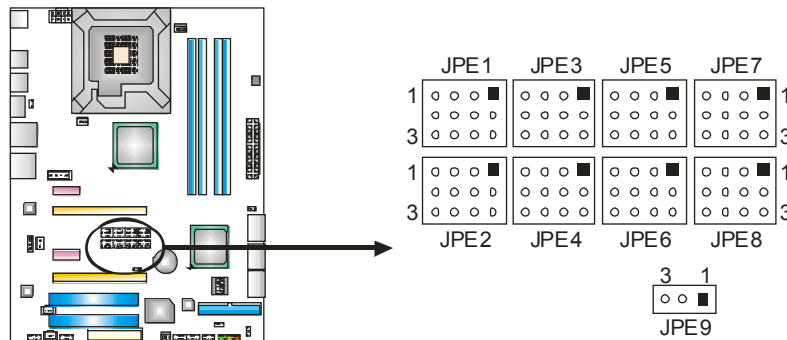

**Pin 1-2 Close**  
 Normal Operation  
 PEX16\_1: x16 Speed  
 PEX16\_2: Not Functional

**Pin 2-3 Close:**  
 CrossFire Operation  
 PEX16\_1: x8 Speed  
 PEX16\_2: x8 Speed

**Step 2:** Insert the two CrossFire-Ready graphics cards into PEX16\_1 (Master) and PEX16\_2 (Slave)

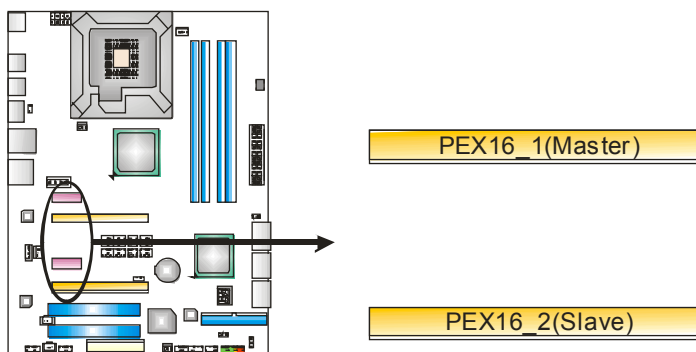

**Notice:** Make sure both the graphics cards are seated into slots completely.

**Step 3:** Connect a 4-pin ATX power cable to Auxiliary Power Connector (J1), this will ensure the stabilization of your system.

**Step 4:** Connect the CrossFire Bridge with two graphics cards. Installation completes.

**NOTE**

For more detail information of hardware/software installation and configuration of CrossFire function, please visit following web-sites:

<http://ati.amd.com/technology/crossfire/tutorials.html>

<http://ati.amd.com/technology/crossfire/howitworksdemo.html>



## CHAPTER 5: RAID FUNCTIONS

### 5.1 OPERATION SYSTEM

Supports Windows 2000 Professional, Windows XP, and Windows VISTA.

### 5.2 RAID ARRAYS

RAID supports the following types of RAID arrays:

**RAID 0:** RAID 0 defines a disk striping scheme that improves disk read and write times for many applications.

**RAID 1:** RAID 1 defines techniques for mirroring data.

**RAID 1+0 (Onboard):** RAID 1+0 combines the techniques used in RAID 0 and RAID 1.

**RAID 5 (Onboard):** RAID 5 provides fault tolerance and better utilization of disk capacity.

### 5.3 How RAID WORKS

#### **RAID 0:**

The controller “stripes” data across multiple drives in a RAID 0 array system. It breaks up a large file into smaller blocks and performs disk reads and writes across multiple drives in parallel. The size of each block is determined by the stripe size parameter, which you set during the creation of the RAID set based on the system environment. This technique reduces overall disk access time and offers high bandwidth.

#### **Features and Benefits**

- **Drives:** Minimum 2, and maximum is up to 6 or 8. Depending on the platform.
- **Uses:** Intended for non-critical data requiring high data throughput, or any environment that does not require fault tolerance.
- **Benefits:** provides increased data throughput, especially for large files. No capacity loss penalty for parity.
- **Drawbacks:** Does not deliver any fault tolerance. If any drive in the array fails, all data is lost.
- **Fault Tolerance:** No.

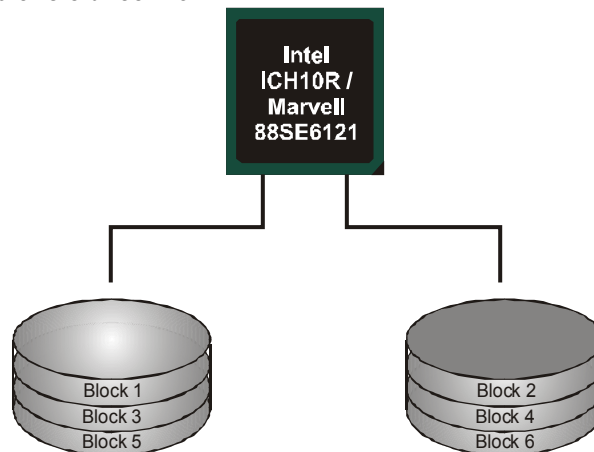

**RAID 1:**

Every read and write is actually carried out in parallel across 2 disk drives in a RAID 1 array system. The mirrored (backup) copy of the data can reside on the same disk or on a second redundant drive in the array. RAID 1 provides a hot-standby copy of data if the active volume or drive is corrupted or becomes unavailable because of a hardware failure. RAID techniques can be applied for high-availability solutions, or as a form of automatic backup that eliminates tedious manual backups to more expensive and less reliable media.

**Features and Benefits**

- **Drives:** Minimum 2, and maximum is 2.
- **Uses:** RAID 1 is ideal for small databases or any other application that requires fault tolerance and minimal capacity.
- **Benefits:** Provides 100% data redundancy. Should one drive fail, the controller switches to the other drive.
- **Drawbacks:** Requires 2 drives for the storage space of one drive. Performance is impaired during drive rebuilds.
- **Fault Tolerance:** Yes.

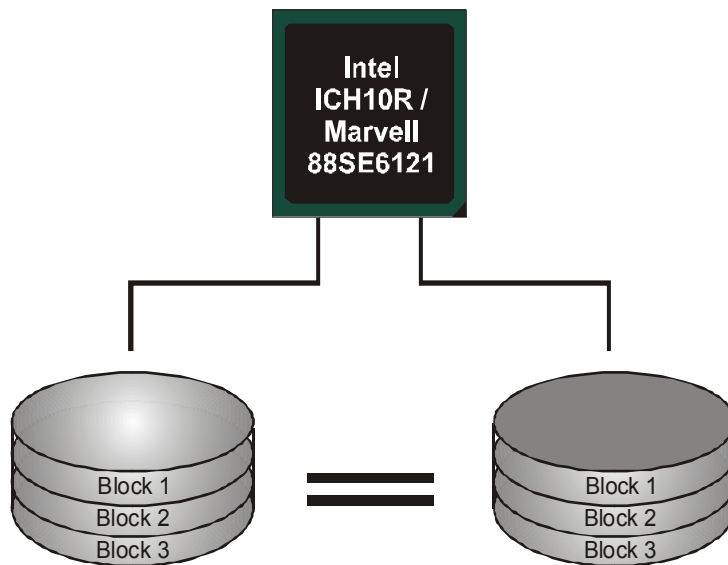

**RAID 1+0 (For Onboard SATA Only):**

RAID 1 drives can be striped using RAID 0 techniques. Resulting in a RAID 1+0 solution for improved resiliency, performance and rebuild performance.

**Features and Benefits**

- **Drives:** Minimum 4, and maximum is 6 or 8, depending on the platform.
- **Benefits:** Optimizes for both fault tolerance and performance, allowing for automatic redundancy. May be simultaneously used with other RAID levels in an array, and allows for spare disks.
- **Drawbacks:** Requires twice the available disk space for data redundancy, the same as RAID level 1.
- **Fault Tolerance:** Yes.

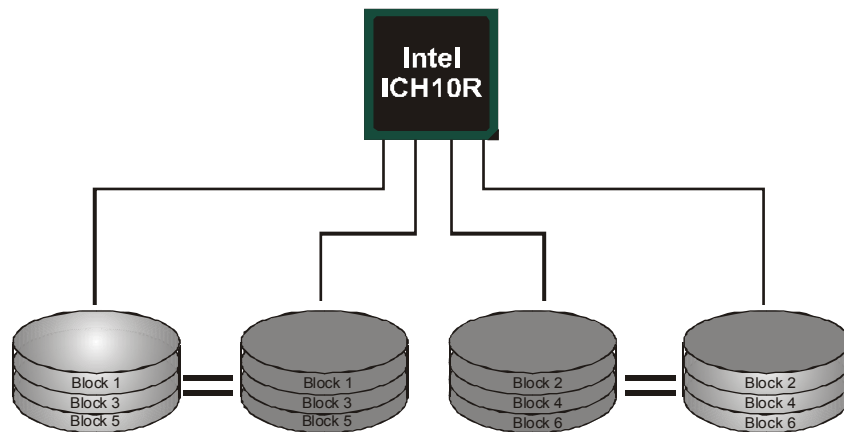

**RAID 5 (For Onboard SATA Only):**

RAID 5 stripes both data and parity information across three or more drives. It writes data and parity blocks across all the drives in the array. Fault tolerance is maintained by ensuring that the parity information for any given block of data is placed on a different drive from those used to store the data itself.

**Features and Benefits**

- **Drives:** Minimum 3.
- **Uses:** RAID 5 is recommended for transaction processing and general purpose service.
- **Benefits:** An ideal combination of good performance, good fault tolerance, and high capacity and storage efficiency.
- **Drawbacks:** Individual block data transfer rate same as a single disk. Write performance can be CPU intensive.
- **Fault Tolerance:** Yes.

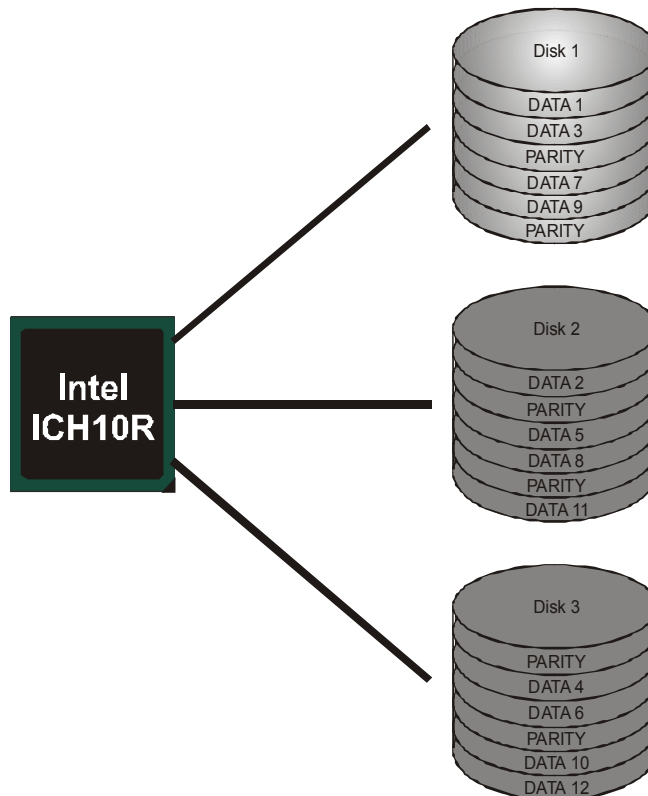

## CHAPTER 6: T-POWER BIOS & SOFTWARE

### 6.1 T-POWER BIOS

#### T-Power BIOS Features

- Overclocking Navigator Engine (O.N.E.)
- Memory Integration Test (M.I.T., under Overclock Navigator Engine)
- BIO-Flasher: Update BIOS file from USB Flash Drive or FDD
- Self Recovery System (S.R.S)
- Smart Fan Function
- CMOS Reloading Program

#### **!! WARNING !!**

For better system performance, the BIOS firmware is being continuously updated. The BIOS information described below in this manual is for your reference only and the actual BIOS information and settings on board may be different from this manual. For further information of setting up the BIOS, please refer to the BIOS Manual in the Setup CD.

#### A. Overclocking Navigator Engine (O.N.E.)

ONE provides two powerful overclocking engines: MOS and AOS for both Elite and Casual overclockers.

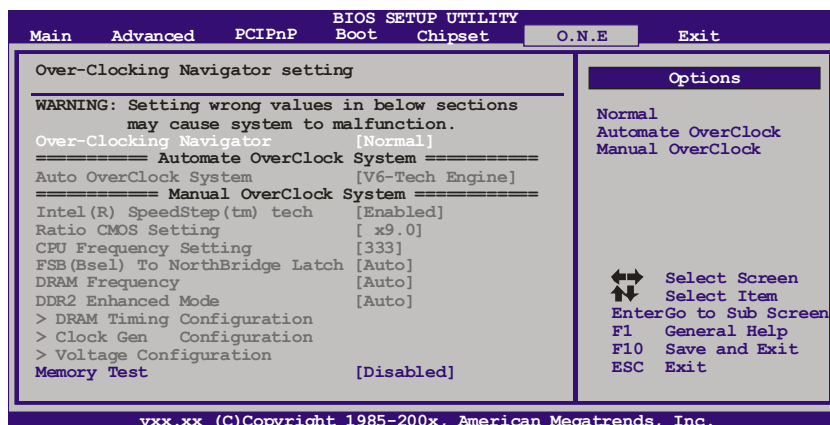

## Manual Overclock System (M.O.S.)

MOS is designed for experienced overclock users. It allows users to customize personal overclock settings.

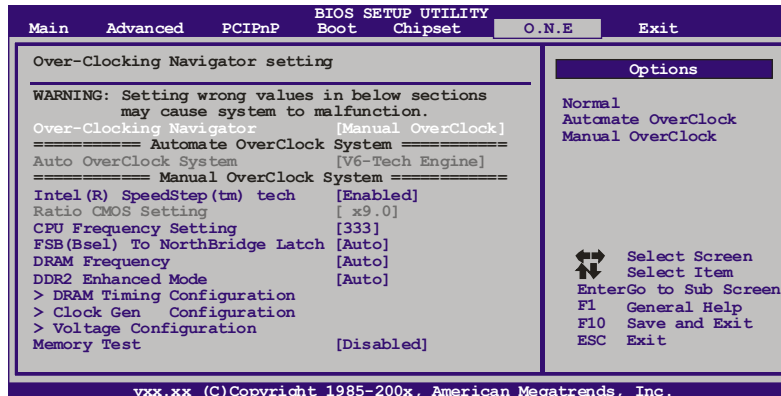
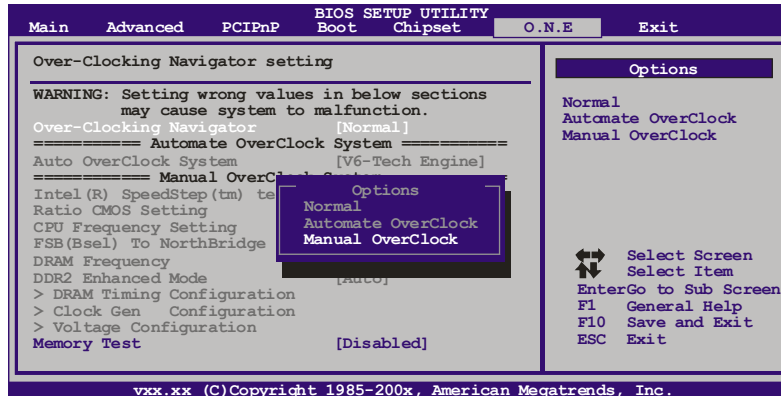

### Intel(R) SpeedStep(tm) Tech

This item allows you to enable SpeedStep technology for better power saving. SpeedStep is a technology built into some Intel processors that allows the clock speed of the processor to be dynamically changed by software.

### Ratio CMOS Setting

This item allows you to set the CPU ratio frequency. This item is adjustable only when SpeedStep Tech is set to Disabled.

### CPU Frequency Setting

CPU Frequency is directly in proportion to system performance. To maintain the system stability, CPU voltage needs to be increased also when raising CPU frequency.

**FSB(Bsel) To NorthBridge Latch**

This item allows you to select the FSB Frequency.

**DRAM Frequency**

To get better system performance, sometimes downgrading the memory frequency is necessary when CPU frequency is adjusted over the upper limit.

**DDR2 Enhanced Mode**

This item allows you to control the DDR2 ram enhanced mode.

**DRAM Timing Configuration**

Enter this item for more advanced DRAM timing settings.

**Clock Gen Configuration**

Enter this item for more advanced Clock Gen settings.

**Voltage Configuration**

Enter this item for more advanced voltage settings.

**NOTE**

Overclock is an optional process, but not a “must-do” process; it is not recommended for inexperienced users. Therefore, we will not be responsible for any hardware damage which may be caused by overclocking. We also would not guarantee any overclocking performance.

**Automatic Overclock System (A.O.S.)**

For beginners in overclock field, BET had developed an easy, fast, and powerful feature to increase the system performance, named A.O.S. Based on many tests and experiments, A.O.S. provides 3 ideal overclock configurations that are able to raise the system performance in a single step.

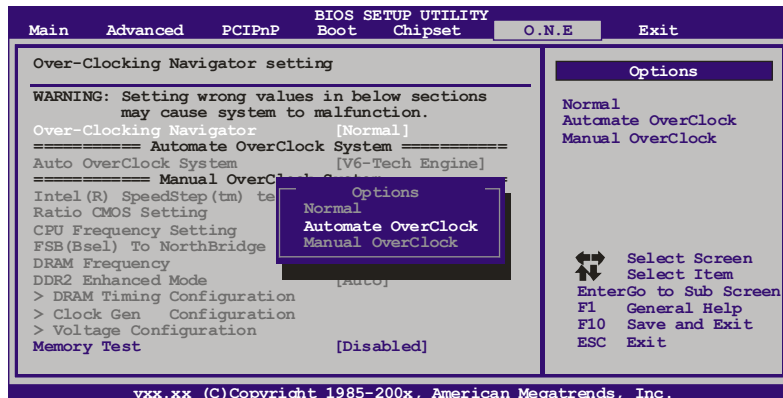

### V6 Tech Engine

This engine will make a good over-clock performance.

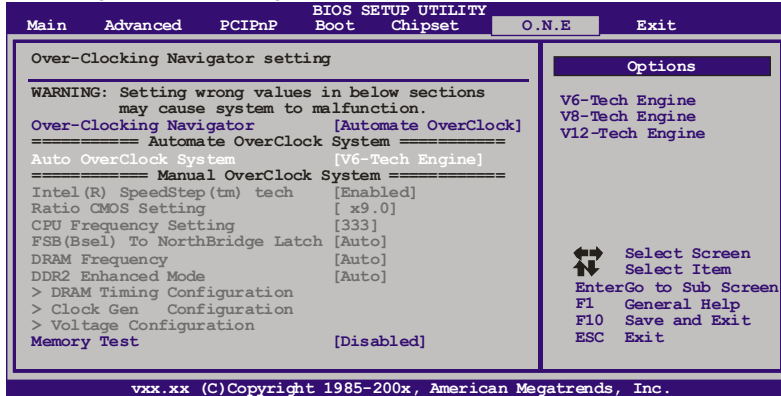

### V8 Tech Engine

This engine will make a better over-clock performance.

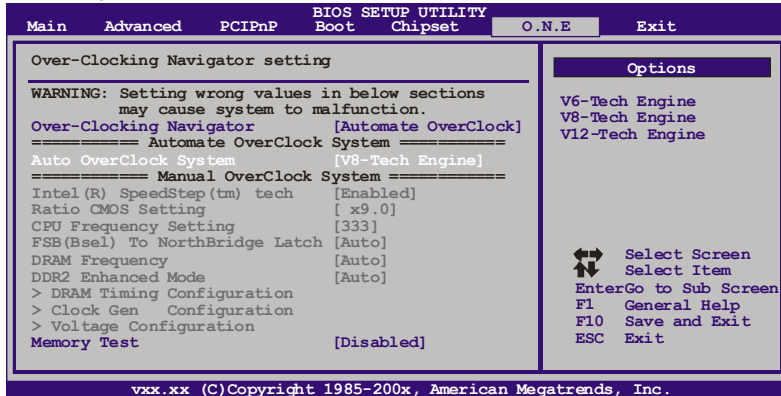

### V12 Tech Engine

This engine will make a best over-clock performance.

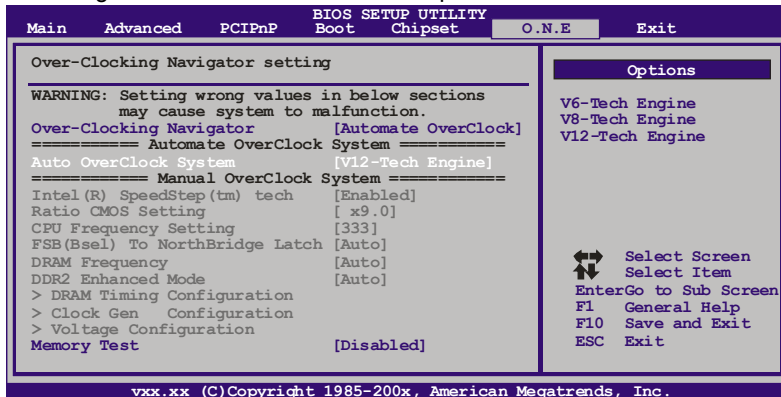



**Notices:**

Not all types of Intel CPU perform above overclock setting ideally; the difference will be based on the selected CPU model.

**B. Memory Integration Test (M.I.T.)**

This function is under “Overclocking Navigator Engine” item.

MIT allows users to test memory compatibilities, and no extra devices or software are needed.

**Step 1**

The default setting under this item is “Disabled”; the condition parameter should be changed to “Enable” to proceed this test.

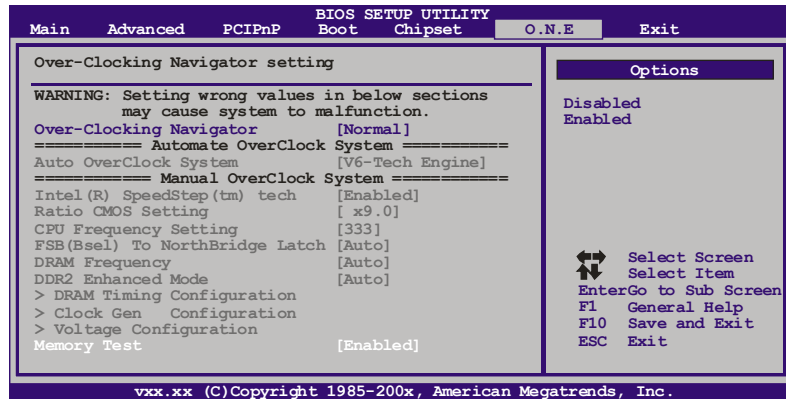
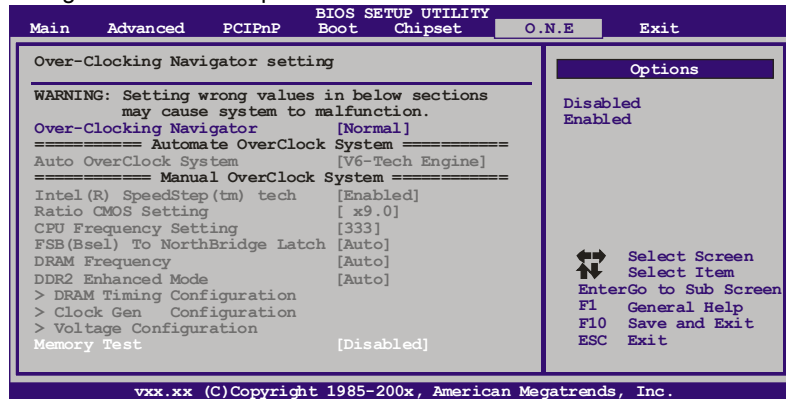

**Step 2**

Save and Exit from CMOS setup and reboot the system to activate this test.

Run this test for 5 minutes (minimum) to ensure the memory stability.

**Step 3**

When the process is done, change the setting back from “Enable” to “Disable” to complete the test.

### C. BIO-Flasher

BIO-Flasher is a BIOS flashing utility providing you an easy and simple way to update your BIOS via USB pen drive or floppy disk.

The BIO-Flasher is built in the BIOS chip. To enter the utility, **press <F12>** during the **Power-On Self Tests (POST)** procedure while booting up.

#### Updating BIOS with BIO-Flasher

1. Go to the website to download the latest BIOS file for the motherboard.
2. Then, save the BIOS file into a USB pen drive or a floppy disk.
3. Insert the USB pen drive or the floppy disk that contains the BIOS file to the USB port or the floppy disk drive.
4. Power on or reset the computer and then press **<F12>** during the **POST** process. A select dialog as the picture on the right appears. Select the device contains the BIOS file and press **<Enter>** to enter the utility.

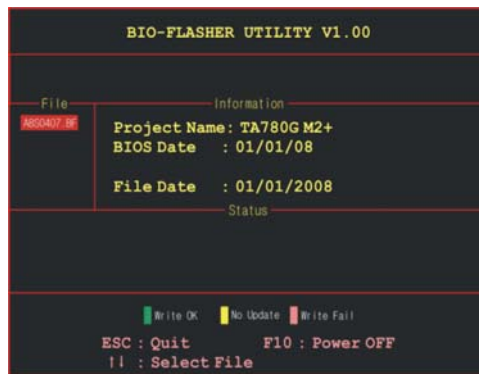

5. The utility will show the BIOS files and their respective information. Select the proper BIOS file and press **<Enter>** then **<Y>** to perform the BIOS update process.

6. After the update process, the utility will ask you to reboot the system. Press **<Y>** to proceed. BIOS update completes.



- This utility only allows storage device with FAT32/16 format and single partition.
- Shutting down or resetting the system while updating the BIOS will lead to system boot failure.

### D. Self Recovery System (S.R.S.)

This function can't be seen under BIOS setup; and is always on whenever the system starts up.

However, it can prevent system hang-up due to inappropriate overclock actions.

When the system hangs up, S.R.S. will automatically log in the default BIOS setting, and all overclock settings will be re-configured.

### E. Smart Fan Function

Smart Fan Function is under "Smart Fan Configuration" in "Advanced Menu".

This is a brilliant feature to control CPU/System Temperature vs. Fan speed.

When enabling Smart Fan function, Fan speed is controlled automatically by CPU/System temperature.

This function will protect CPU/System from overheat problem and maintain the system temperature at a safe level.

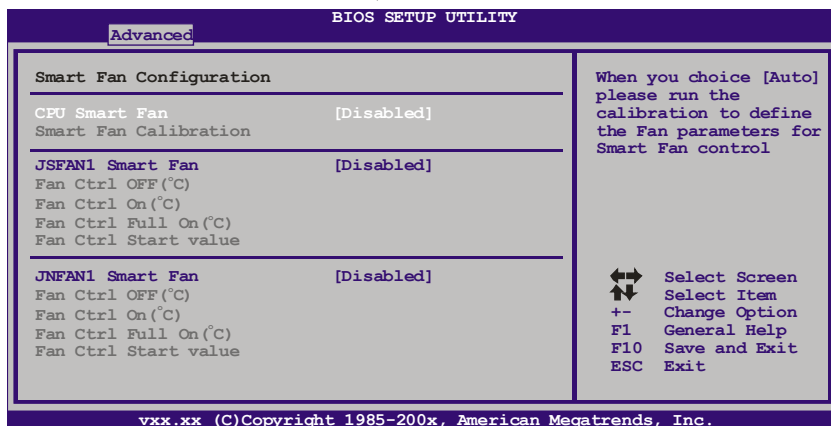
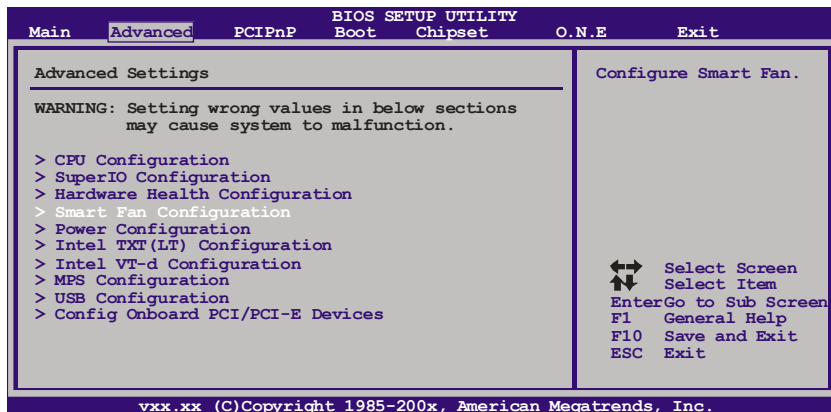

### Smart Fan Calibration

Choose this item and then the BIOS will automatically test and detect the CPU/System fan functions and show CPU/System fan speed.

### Fan Ctrl OFF(°C)

If the CPU/System temperature is lower than the set value, the CPU/System fan will turn off. The range is from 0~127, with an interval of 1.

### Fan Ctrl On(°C)

The CPU/System fan starts to work when CPU/System temperature arrives to this set value. The range is from 0~127, with an interval of 1.

### Fan Ctrl Full On(°C)

If the System Temperature reaches the set value, FAN will run in full speed. The range is from 0~127, with an interval of 1.

### Fan Ctrl Start Value

When CPU/System temperature arrives to the set value, the CPU/System fan will work under Smart Fan Function mode. The range is from 0~127, with an interval of 1.

## F. CMOS Reloading Program

It allows users to save different CMOS settings into BIOS-ROM.

Users are able to reload any saved CMOS setting for customizing system configurations. Moreover, users are able to save an ideal overclock setting during overclock operation.

There are 10 sets of record addresses in total, and users are able to name the CMOS data according to personal preference.

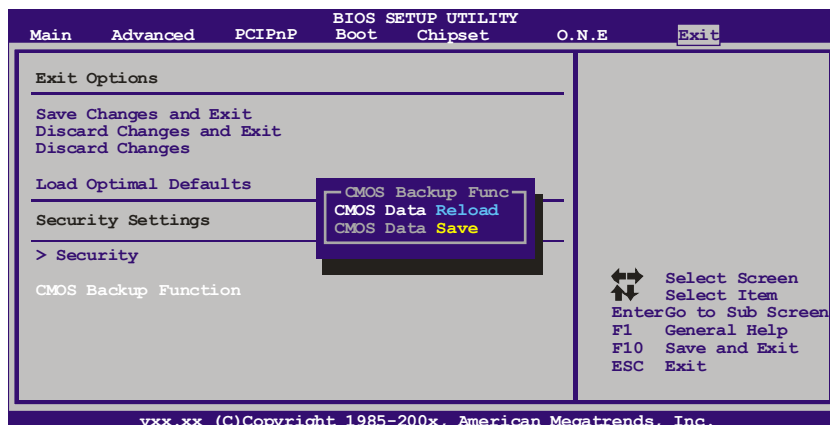

## 6.2 T-POWER SOFTWARE

T-Power2 is an integration of four functions: **OC Tweaker** for over-clock, **eHot-Line** for technical support, **BIOS-watch** for system monitor, and **Biostar Flash** for BIOS update.

### Installing T-Power2

1. Insert the Setup CD to the optical drive. The drivers installation program would appear if the Autorun function has been enabled.
2. Select **Software Installation**, and then click on **T-Power2**.
3. Follow the on-screen instructions to complete the installation.

### Launching T-Power2

After the installation process, you will see a “TPower2” icon appears on the desktop. Double-click the **TPower2** icon to launch T-Power2 utility.



### Main Panel

The main panel provides OC Tweaker, eHot-Line, BIO-watch, and Biostar Flash buttons for launching the respective programs. Besides you can also change the skin of the main panel.



## OC Tweaker



On the main panel, you can click on the OC Tweaker button to launch this function. The OC Tweaker provides automatic/manual over-clock function for BIOSTAR motherboard, and even for some BIOSTAR VGA card (VR8xxx series only) which is powered by V-Ranger.

This area shows clock information of the VGA card

This area shows clock/voltage information of the CPU/motherboard

V3/V6/V9/V12/V15 Fixed mode over-clock

- Test the system
- Auto over-clock
- Delete current setting file
- Save current setting into file
- Restore hardware default setting
- Load previously saved setting file

If you are not using a nVIDIA VGA card, this window will not show.

The left window will show like this only when you are using a VR8xxx series BIOSTAR VGA card.

- Test the VGA card
- Manual over-clock
- Restore VGA card default setting
- Power Saving Mode
- Save current VGA setting into file
- Delete current VGA setting file
- Load previous saved VGA setting file

If you have installed a V-Ranger powered BIOSTAR VGA card, then the left window of the VGA card information would show like this. VGA card over-clock function will be enabled.

<Auto Over-clock>

By this function, the utility will set the best and stable performance and frequency automatically.



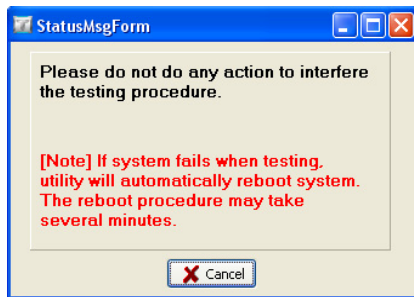
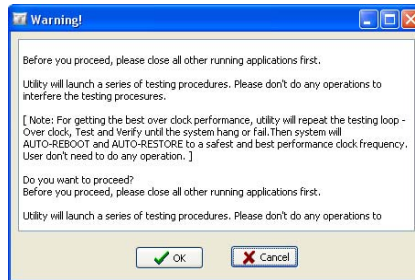



Click on  then a Warning dialog will show. This dialog tells that all running applications should be closed before the auto over-clock procedure. The utility will do a series of test continually; do not do any operation during the test procedure. Click **OK** to proceed or **Cancel** to stop.



After proceeding the tests would start, and a warning message would continually show telling that do not do any action to interfere the testing procedure. The testing procedure takes minutes; you can stop the procedure by clicking **Cancel**.

For getting the best performance, the utility will repeat the test continually until the system hang or fail, and then the system will auto-reboot. After that, launch the T-Power2 and enter the OC Tweaker again, you will find the setting has been restored to a safest and best performance status. Save this setting is recommended.

<Manual Over-clock>

To manually adjust the clock and voltage, just click the  or  beside the number. (For V-Ranger powered VGA card, click  then the   beside the VGA values will show.) After the adjustment, click  to verify the supplied value is recommended. If the test passes, following dialog will show; click OK to proceed.

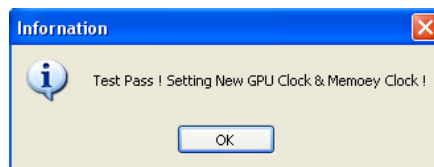
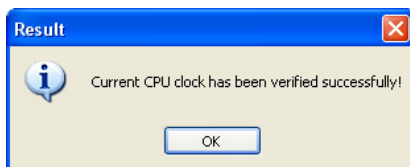

<V3/V6/V9/V12/V15 Engine>

By clicking , the utility would over-clock the system with certain fixed percentage. When the V3/V6/V9/V12/V15 engine is activated, you will see the green light bar on the left rising to the top of the button. This function is recommended for any inexperienced users.

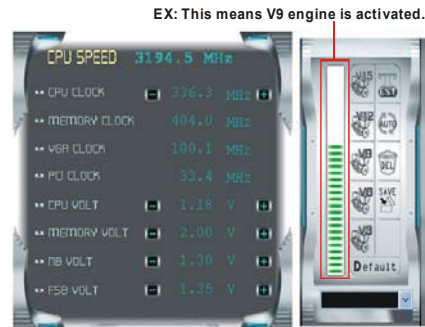

<Save/Load/Delete Setting>

You can save current setting to a file by clicking , then a dialog as bellow will show.



Enter file name and click "Save", and then the current setting would be saved.

To load a previously saved file, click on , and the saved files would show as bellow. Click on the file name and then choose "Yes" to load the setting.

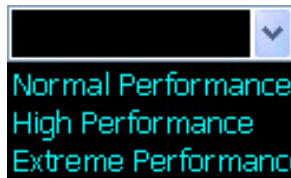

To delete a previously saved file; load the setting first → click on  (for VGA setting is **Delete**) → choose "Yes", and the setting file will be deleted.

(Be aware of that VGA setting for V-Ranger powered VGA card must be saved/loaded/deleted respectively.)

 Over-clock is an optional process but not a "must-do" process, and actual over-clock result varies by every individual PC system. Therefore, we will neither guarantee any over-clock performance nor be responsible for any system damage that may be caused by over-clock. Any values or performance shown above are for reference only.



## BIO-watch



BIO-watch is a control and monitor utility that helps you to maintain the health of the PC. It provides real-time information of CPU/GPU/System temperature, fan speed, and voltage; and fan control function.

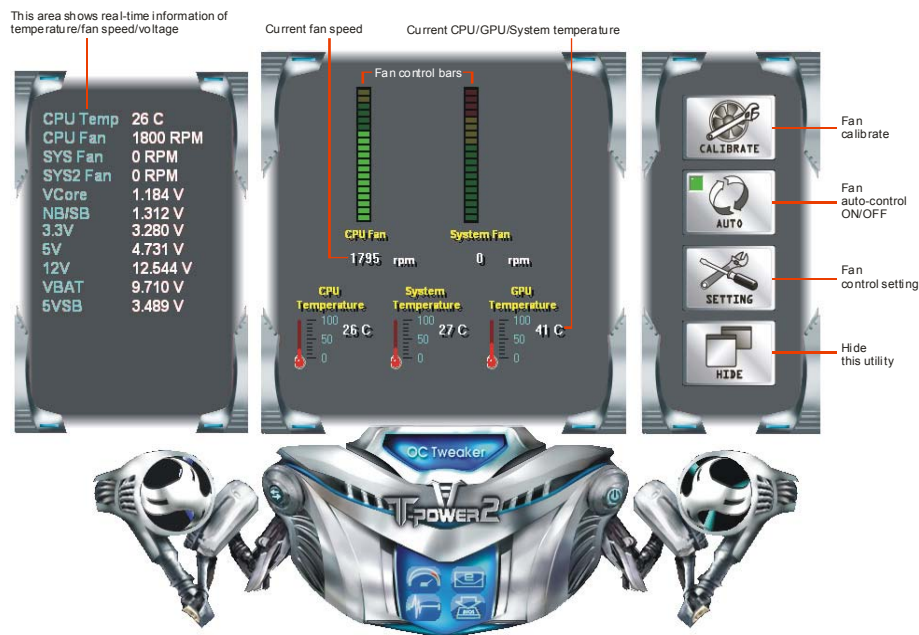

### <Fan Calibrate>

At the very first time entering this utility, fan calibrate will be made automatically.



After that you can also click **CALIBRATE** to manually calibrate the fan.



### <Fan Auto/Manual Control>

When the "AUTO" button looks like  , it means fans are under

auto-control. Click the button to  then you can manually adjust fan speed.

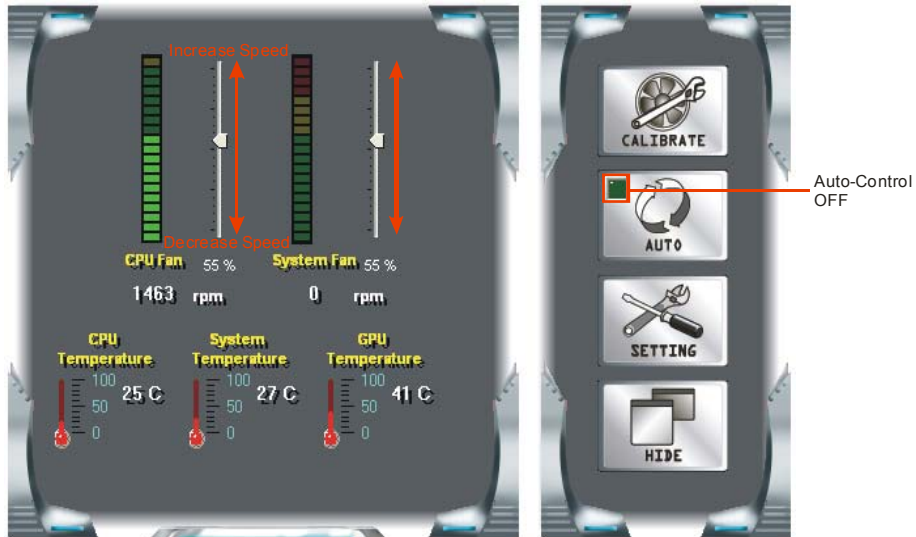

Click the auto-control off and then the adjust level will show; use the level to increase/decrease the fan speed. Be aware if the fan level been down to 0%, the fan will still not completely stop; this is for your system's protection.

**<Fan Control Settings>**

Click  to enter the fan control setting dialog. Here you can set CPU temperature to control the fan; including target CPU temperature, CPU temperature for full fan speed, and CPU temperature for shutdown system. Besides, you can also see system information in this dialog.

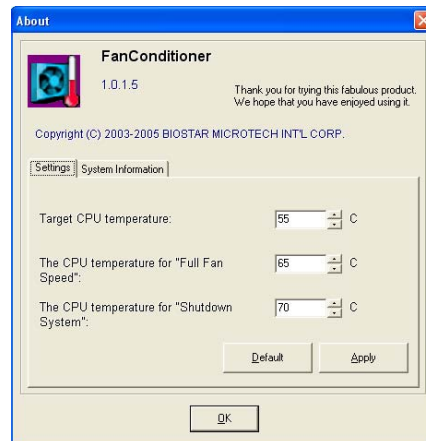

## eHot-Line

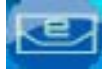

eHot-Line is a convenient utility that helps you to contact with our Tech-Support system. This utility will collect the system information which is useful for analyzing the problem you may have encountered, and then send these information to our tech-support department to help you fix the problem.

**⚠ Before you use this utility, please set Outlook Express as your default e-mail client application program.**

The main panel of eHot-Line shows BIOS information, motherboard model name, and chipset information, click on **"SETTING"** to enter.



The Privacy Statement shows; and please read through it. If you agree with the statement, click **"Yes"** to proceed; If not, click **"No"** to leave.

After agreeing with the privacy statement, fill up the table in the following dialog.

**\* represents important information that you must provide. Without this information, you may not be able to send out the mail.**

**\*Describe condition of your system.**

**\*Select your area or the area close to you.**

**Provide the e-mail address that you would like to send the copy to.**

**\*Provide the name of the memory module manufacturer.**

**Provide the name of the power supply manufacturer and the model no.**

**Exit this dialog.**

**Send the mail out.**

**Save these information to a .txt file**

**This block will show the information which would be collected in the mail.**

Symptom Description :  
System can not wake up after S3 sleep.

Region :  
United States

E Mail CC :  
xxxx@xxx.xxx.xxx.xx

Memory Module Manufacture :  
xxx DDR II

Power Supply Manufacture/model :  
xxx 500W Power

Base board information :  
Caption : Base Board  
CreationClassName : Win32\_BaseBoard  
Description : Base Board  
HostingBoard : TRUE  
Manufacturer : Biostar Group  
Name : Base Board  
PoweredOn : TRUE

Buttons: Send, Save As..., Exit

After filling up this information, click **“Send”** to send the mail out. A warning dialog would appear asking for your confirmation; click **“Send”** to confirm or **“Do Not Send”** to cancel.

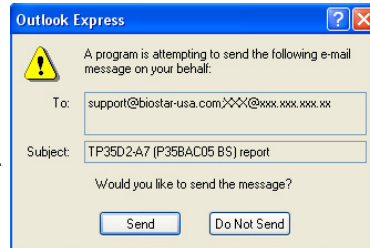

If you want to save this information to a .txt file, click **“Save As...”** and then you will see a saving dialog appears asking you to enter file name.

Enter the file name and then click **“Save”**. Your system information will be saved to a .txt file.

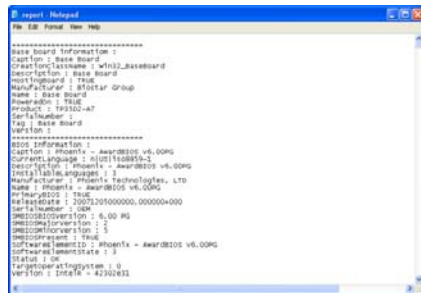
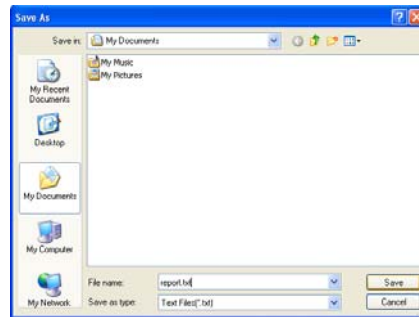

Open the saved .txt file, you will see your system information including motherboard/BIOS/CPU/video/device/OS information. This information is also concluded in the sent mail.



**We will not share customer's data with any other third parties, so please feel free to provide your system information while using eHot-Line service.**



If you are not using Outlook Express as your default e-mail client application, you may need to save the system information to a .txt file and send the file to our tech support with other e-mail application. Go to the following web <http://www.biostar.com.tw/app/en-us/about/contact.php> for getting our contact information.

## Biostar Flash



Biostar Flash is a convenient utility which allows you to update your motherboard BIOS under Windows system.

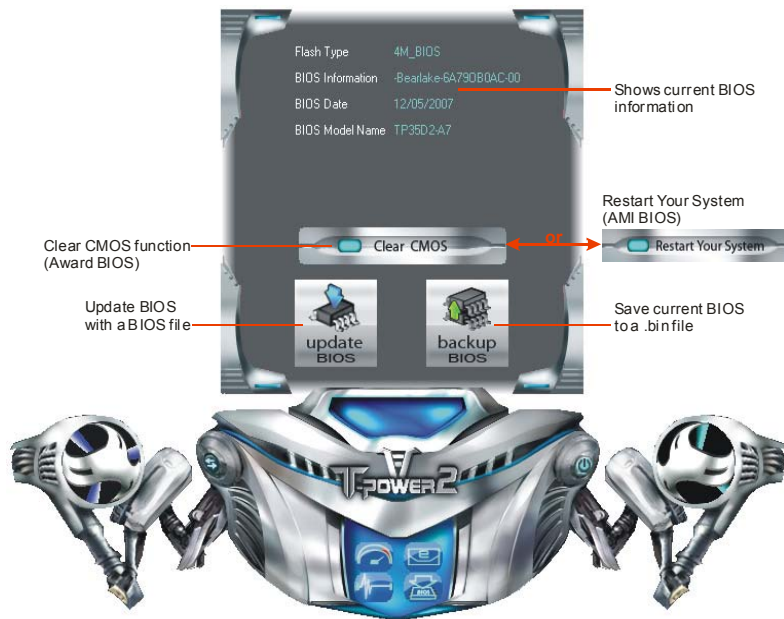

### <Backup BIOS>

Once click on this button, the saving dialog will show. Choose the position to save file and enter file name. (We recommend that the file name should be English/number and no longer than 7 characters.) Then click **Save**.

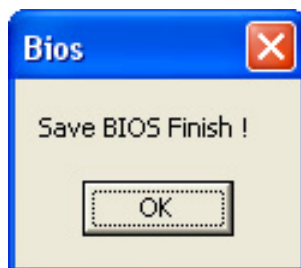
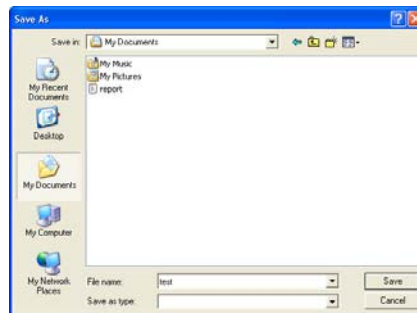

After the saving process, finish dialog will show. Click on **OK** to complete the BIOS Backup procedure.

### <Update BIOS>

Before doing this, please download the proper BIOS file from our website:  
[www.biostar.com.tw](http://www.biostar.com.tw)

Update BIOS procedure should be run with Clear CMOS (or Restart) function, so please check on Clear CMOS (or Restart) first.

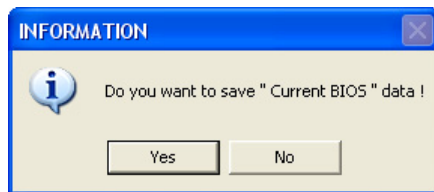

Then click Update BIOS button, a dialog will show for asking you backup current BIOS. Click **Yes** for BIOS backup and refer to the Backup BIOS procedure; or click **No** to skip this procedure.

After the BIOS Backup procedure, the open dialog will show for requesting the BIOS file which is going to be updated. Please choose the proper BIOS file for updating, then click on **Open**.

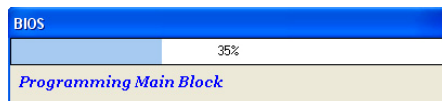
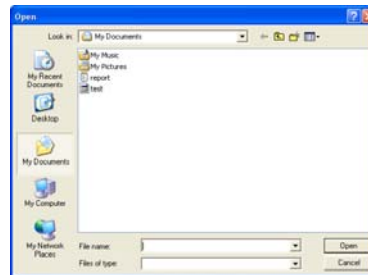

The utility will update BIOS with the proper BIOS file.

After the BIOS Update process, click on **OK** to restart the system.

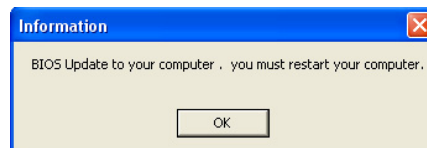

While the system boots up and the full screen logo shows, press  <Delete> key to enter BIOS setup.

In the BIOS setup, choose **Load Optimized Defaults** and press **<Enter>→<Y>→<Enter>**. After that use **Save and Exit Setup** to exit BIOS setup. BIOS Update is completed.



All the information and content above about the T-Power 2 utility are subject to be changed without notice. For better performance, the utility is being continuously updated. The information and pictures described above are for your reference only. The actual information and settings on board may be slightly different from this manual.

## CHAPTER 7: USEFUL HELP

### 7.1 DRIVER INSTALLATION NOTE

After you installed your operating system, please insert the Fully Setup Driver CD into your optical drive and install the driver for better system performance.

You will see the following window after you insert the CD



The setup guide will auto detect your motherboard and operating system.

**Note:**

If this window didn't show up after you insert the Driver CD, please use file browser to locate and execute the file **SETUP.EXE** under your optical drive.

#### A. Driver Installation

To install the driver, please click on the Driver icon. The setup guide will list the compatible driver for your motherboard and operating system. Click on each device driver to launch the installation program.

#### B. Software Installation

To install the software, please click on the Software icon. The setup guide will list the software available for your system, click on each software title to launch the installation program.

#### C. Manual

Aside from the paperback manual, we also provide manual in the Driver CD. Click on the Manual icon to browse for available manual.

**Note:**

You will need Acrobat Reader to open the manual file. Please download the latest version of Acrobat Reader software from <http://www.adobe.com/products/acrobat/readstep2.html>

## 7.2 EXTRA INFORMATION

### ***CPU Overheated***

If the system shutdown automatically after power on system for seconds, that means the CPU protection function has been activated.

When the CPU is over heated, the motherboard will shutdown automatically to avoid a damage of the CPU, and the system may not power on again.

In this case, please double check:

1. The CPU cooler surface is placed evenly with the CPU surface.
2. CPU fan is rotated normally.
3. CPU fan speed is fulfilling with the CPU speed.

After confirmed, please follow steps below to relief the CPU protection function.

1. Remove the power cord from power supply for seconds.
2. Wait for seconds.
3. Plug in the power cord and boot up the system.

Or you can:

1. Clear the CMOS data.  
(See "Close CMOS Header: JCMOS1" section)
2. Wait for seconds.
3. Power on the system again.



## 7.3 AMI BIOS BEEP CODE

### Boot Block Beep Codes

Number of Beeps	Description
1	No media present. (Insert diskette in floppy drive A:)
2	"AMIBOOT.ROM" file not found in root directory of diskette in A:
3	Insert next diskette if multiple diskettes are used for recovery
4	Flash Programming successful
5	File read error
7	No Flash EPROM detected
10	Flash Erase error
11	Flash Program error
12	"AMIBOOT.ROM" file size error
13	BIOS ROM image mismatch (file layout does not match image present in flash device)

### POST BIOS Beep Codes

Number of Beeps	Description
1	Memory refresh timer error
3	Base memory read/write test error
6	Keyboard controller BAT command failed
7	General exception error (processor exception interrupt error)
8	Display memory error (system video adapter)

### Troubleshooting POST BIOS Beep Codes

Number of Beeps	Troubleshooting Action
1, 3	Reseat the memory, or replace with known good modules.
6, 7	<p>Fatal error indicating a serious problem with the system. Consult your system manufacturer. Before declaring the motherboard beyond all hope, eliminate the possibility of interference by a malfunctioning add-in card. Remove all expansion cards except the video adapter.</p> <ul style="list-style-type: none"> <li>● If beep codes are generated when all other expansion cards are absent, consult your system manufacturer's technical support.</li> <li>● If beep codes are not generated when all other expansion cards are absent, one of the add-in cards is causing the malfunction. Insert the cards back into the system one at a time until the problem happens again. This will reveal the malfunctioning card.</li> </ul>
8	If the system video adapter is an add-in card, replace or reseat the video adapter. If the video adapter is an integrated part of the system board, the board may be faulty.

## 7.4 AMI BIOS POST CODE

Checkpoint	Description
03	Disable NMI, Parity, video for EGA, and DMA controllers. Initialize BIOS, POST, Runtime data area. Also initialize BIOS modules on POST entry and GPNV area. Initialized CMOS as mentioned in the Kernel Variable "wCMOSFlags."
04	Check CMOS diagnostic byte to determine if battery power is OK and CMOS checksum is OK. Verify CMOS checksum manually by reading storage area. If the CMOS checksum is bad, update CMOS with power-on default values and clear passwords. Initialize status register A. Initializes data variables that are based on CMOS setup questions. Initializes both the 8259 compatible PICs in the system
05	Initializes the interrupt controlling hardware (generally PIC) and interrupt vector table.
06	Do RW test to CH-2 count reg. Initialize CH-0 as system timer. Install the POSTINT1Ch handler. Enable IRQ-0 in PIC for system timer interrupt. Traps INT1Ch vector to "POSTINT1ChHandlerBlock."
07	Fixes CPU POST interface calling pointer.
08	Initializes the CPU. The BAT test is being done on KBC. Program the keyboard controller command byte is being done after Auto detection of KB/MS using AMI KB-5.
C0	Early CPU Init Start -- Disable Cache -- Init Local APIC.
C1	Set up boot strap processor Information.
C2	Set up boot strap processor for POST.
C5	Enumerate and set up application processors.
C6	Re-enable cache for boot strap processor.
C7	Early CPU Init Exit.
0A	Initializes the 8042 compatible Key Board Controller.
0B	Detects the presence of PS/2 mouse.
0C	Detects the presence of Keyboard in KBC port.
0E	Testing and initialization of different Input Devices. Also, update the Kernel Variables. Traps the INT09h vector, so that the POST INT09h handler gets control for IRQ1. Uncompress all available language, BIOS logo, and Silent logo modules.
13	Early POST initialization of chipset registers.
20	Relocate System Management Interrupt vector for all CPU in the system.
24	Uncompress and initialize any platform specific BIOS modules. GPNV is initialized at this checkpoint.
2A	Initializes different devices through DIM. See DIM Code Checkpoints section of document for more information.
2C	Initializes different devices. Detects and initializes the video adapter installed in the system that have optional ROMs.
2E	Initializes all the output devices.
31	Allocate memory for ADM module and uncompress it. Give control to ADM module for initialization. Initialize language and font modules for ADM. Activate ADM module.
33	Initializes the silent boot module. Set the window for displaying text information.

Checkpoint	Description
37	Displaying sign-on message, CPU information, setup key message, and any OEM specific information.
38	Initializes different devices through DIM. See DIM Code Checkpoints section of document for more information. USB controllers are initialized at this point.
39	Initializes DMAC-1 & DMAC-2.
3A	Initialize RTC date/time.
3B	Test for total memory installed in the system. Also, Check for DEL or ESC keys to limit memory test. Display total memory in the system.
3C	Mid POST initialization of chipset registers.
40	Detect different devices (Parallel ports, serial ports, and coprocessor in CPU, etc.) successfully installed in the system and update the BDA, EBDA...etc.
52	Updates CMOS memory size from memory found in memory test. Allocates memory for Extended BIOS Data Area from base memory. Programming the memory hole or any kind of implementation that needs an adjustment in system RAM size if needed.
60	Initializes NUM-LOCK status and programs the KBD typematic rate.
75	Initialize Int-13 and prepare for IPL detection.
78	Initializes IPL devices controlled by BIOS and option ROMs.
7C	Generate and write contents of ESCD in NVRam.
84	Log errors encountered during POST.
85	Display errors to the user and gets the user response for error.
87	Execute BIOS setup if needed / requested. Check boot password if installed.
8C	Late POST initialization of chipset registers.
8D	Build ACPI tables (if ACPI is supported).
8E	Program the peripheral parameters. Enable/Disable NMI as selected.
90	Initialization of system management interrupt by invoking all handlers. Please note this checkpoint comes right after checkpoint 20h.
A1	Clean-up work needed before booting to OS.
A2	Takes care of runtime image preparation for different BIOS modules. Fill the free area in F000h segment with 0FFh. Initializes the Microsoft IRQ Routing Table. Prepares the runtime language module. Disables the system configuration display if needed.
A4	Initialize runtime language module. Display boot option popup menu.
A7	Displays the system configuration screen if enabled. Initialize the CPU's before boot, which includes the programming of the MTRR's.
A9	Wait for user input at config display if needed.
AA	Uninstall POST INT1Ch vector and INT09h vector.
AB	Prepare BBS for Int 19 boot. Init MP tables.
AC	End of POST initialization of chipset registers. De-initializes the ADM module.
B1	Save system context for ACPI. Prepare CPU for OS boot including final MTRR values.
00	Passes control to OS Loader (typically INT19h).

## 7.5 TROUBLESHOOTING

Probable	Solution
<ol style="list-style-type: none"> <li>1. No power to the system at all. Power light don't illuminate, fan inside power supply does not turn on.</li> <li>2. Indicator light on keyboard does not turn on.</li> </ol>	<ol style="list-style-type: none"> <li>1. Make sure power cable is securely plugged in.</li> <li>2. Replace cable.</li> <li>3. Contact technical support.</li> </ol>
<p>System inoperative. Keyboard lights are on, power indicator lights are lit, and hard drive is spinning.</p>	<p>Using even pressure on both ends of the DIMM, press down firmly until the module snaps into place.</p>
<p>System does not boot from hard disk drive, can be booted from optical drive.</p>	<ol style="list-style-type: none"> <li>1. Check cable running from disk to disk controller board. Make sure both ends are securely plugged in; check the drive type in the standard CMOS setup.</li> <li>2. Backing up the hard drive is extremely important. All hard disks are capable of breaking down at any time.</li> </ol>
<p>System only boots from optical drive. Hard disk can be read and applications can be used but booting from hard disk is impossible.</p>	<ol style="list-style-type: none"> <li>1. Back up data and applications files.</li> <li>2. Reformat the hard drive. Re-install applications and data using backup disks.</li> </ol>
<p>Screen message says "Invalid Configuration" or "CMOS Failure."</p>	<p>Review system's equipment. Make sure correct information is in setup.</p>
<p>Cannot boot system after installing second hard drive.</p>	<ol style="list-style-type: none"> <li>1. Set master/slave jumpers correctly.</li> <li>2. Run SETUP program and select correct drive types. Call the drive manufacturers for compatibility with other drives.</li> </ol>

This page is intentionally left blank.

## APPENDENCIES: SPEC IN OTHER LANGUAGE

### GERMAN

<i>Spezifikationen</i>		
CPU	LGA 775 Intel Intel Core2Duo / Core2Quad / Pentium Dual-Core / Celeron Dual-Core / Celeron 4xx Prozessoren	Unterstützt Execute Disable Bit / Enhanced Intel SpeedStep® / Intel Architecture-64 / Extended Memory 64 Technology / Virtualization Technology
FSB	800 / 1066 / 1333 / 1600 MHz	
Chipsatz	Intel P45 Intel ICH10R	
Super E/A	Fintek F71887F Bietet die häufig verwendeten alten Super E/A-Funktionen. Low Pin Count-Schnittstelle	Umgebungskontrolle, Hardware-Überwachung Lüfterdrehzahl-Controller/-Überwachung "Smart Guardian"-Funktion von ITE
Arbeitsspeicher	DDR2 DIMM-Steckplätze x 4 Jeder DIMM unterstützt 256MB / 512MB / 1GB / 2GB DDR2. Max. 8GB Arbeitsspeicher	Dual-Kanal DDR2 Speichermodul Unterstützt DDR2 1066 / 800 / 667 registrierte DIMMs. ECC DIMMs werden nicht unterstützt.
IDE	Marvell 88SE6121	Ultra DMA 33 / 66 / 100 / 133 Bus Master-Modus Unterstützt PIO-Modus 0~4,
SATA II	ICH10R	Datentransferrate bis zu 3Gb/s Konform mit der SATA-Spezifikation Version 2.0. Unterstützt RAID 0 / 1 / 5 / 1+0
eSATA	Marvell 88SE6121	Datentransferrate bis zu 3Gb/s Konform mit der SATA-Spezifikation Version 2.0. Unterstützt Port-Multiplier/RAID 0,1
LAN	Realtek RTL 8111C	10 / 100 / 1000 Mb/s Auto-Negotiation Halb-/ Vollduplex-Funktion
HD Audio-Unterstützung	ALC888S	Unterstützt High-Definition Audio 7.1-Kanal-Audioausgabe
Steckplätze	PCI-Steckplatz x2 PCI Express Gen2 x16 Steckplatz (x16/x8) x1 PCI Express Gen2 x16 Steckplatz (x8) x1 PCI Express x1 Steckplatz x2	

<b>Spezifikationen</b>			
Onboard-Anschluss	Diskettenlaufwerkanschluss	x1	Jeder Anschluss unterstützt 2 Diskettenlaufwerke
	Serieller Anschluss	x1	
	IDE-Anschluss	x1	Jeder Anschluss unterstützt 2 IDE-Laufwerke
	SATA-Anschluss	x6	Jeder Anschluss unterstützt 1 SATA-Laufwerk
	Fronttafelanschluss	x1	Unterstützt die Fronttafel-Funktionen
	Front-Audioanschluss	x1	Unterstützt die Fronttafel-Audioanschlussfunktion
	CD-IN-Anschluss	x1	Unterstützt die CD Audio-In-Funktion
	S/PDIF Ausgangsanschluss	x2	Unterstützt die digitale Audioausgabefunktion
	S/PDIF Eingangsanschluss	x1	Unterstützt die digitale Audioeingabefunktion
	CPU-Lüfter-Sockel	x1	CPU-Lüfterstromversorgungsanschluss (mit Smart Fan-Funktion)
	System-Lüfter-Sockel	x2	System-Lüfter-Stromversorgungsanschluss
	"CMOS löschen"-Sockel	x1	
	USB-Anschluss	x3	Jeder Anschluss unterstützt 2 Fronttafel-USB-Anschlüsse
Stromanschluss (24-polig)	x1		
Stromanschluss (8-polig)	x1		
Stromanschluss (4-polig)	x1		
Rückseiten-E/A	PS/2-Tastatur	x1	
	PS/2-Maus	x1	
	LAN-Anschluss	x1	
	USB-Anschluss	x6	
	Audioanschluss	x6	
	eSATA Anschluss	x2	
Platinengröße	244 mm (B) X 305 mm (L)		ATX
OS-Unterstützung	Windows 2000 / XP / VISTA		Biostar behält sich das Recht vor, ohne Ankündigung die Unterstützung für ein Betriebssystem hinzuzufügen oder zu entfernen.

**FRANCE**

SPEC		
UC	LGA 775 Processeurs Intel Core2Duo / Core2Quad / Pentium Dual-Core / Celeron Dual-Core / Celeron 4xx	Prend en charge les technologies d'exécution de bit de désactivation / Intel SpeedStep® optimisée/ d'architecture Intel 64 / de mémoire étendue 64 / de virtualisation
Bus frontal	800 / 1066 / 1333 / 1600 MHz	
Chipset	Intel P45 Intel ICH10R	
Super E/S	Fintek F71887F Fournit la fonctionnalité de Super E/S patrimoniales la plus utilisée. Interface à faible compte de broches	Initiatives de contrôle environnementales, Moniteur de matériel Contrôleur /moniteur de vitesse de ventilateur Fonction "Gardien intelligent" de l'ITE
Mémoire principale	Fentes DDR2 DIMM x 4 Chaque DIMM prend en charge des DDR2 de 256Mo / 512Mo / 1Go / 2Go Capacité mémoire maximale de 8Go	Module de mémoire DDR2 à mode à double voie Prend en charge la DDR2 1066 / 800 / 667 Les DIMM à registres et DIMM avec code correcteurs d'erreurs ne sont pas prises en charge
IDE	Marvell 88SE6121	Mode principale de Bus Ultra DMA 33 / 66 / 100 / 133 Prend en charge le mode PIO 0~4,
SATA II	ICH10R	Taux de transfert jusqu'à 3 Go/s. Conforme à la spécification SATA Version 2.0 Prise en charge RAID 0 / 1 / 5 / 1+0
eSATA	Marvell 88SE6121	Taux de transfert jusqu'à 3 Go/s. Conforme à la spécification SATA Version 2.0 Prise en charge Port-Multiplier/ RAID 0,1
LAN	Realtek RTL 8111C	10 / 100 / 1000 Mb/s négociation automatique Half / Full duplex capability
Prise en charge audio HD	ALC888S	Prise en charge de l'audio haute définition Sortie audio à 7.1 voies
Fentes	Fente PCI x2 Fente PCI Express Gen2 x16 (x16/x8) x1 Fente PCI Express Gen2 x16 (x8) x1 Fente PCI Express x1 x2	



<b>SPEC</b>			
Connecteur embarqué	Connecteur de disquette	x1	Chaque connector prend en charge 2 lecteurs de disquettes
	Port série	x1	
	Connecteur IDE	x1	Chaque connecteur prend en charge 2 périphériques IDE
	Connecteur SATA	x6	Chaque connecteur prend en charge 1 périphérique SATA
	Connecteur du panneau avant	x1	Prend en charge les équipements du panneau avant
	Connecteur Audio du panneau avant	x1	Prend en charge la fonction audio du panneau avant
	Connecteur d'entrée CD	x1	Prend en charge la fonction d'entrée audio de CD
	Connecteur de sortie S/PDIF	x2	Prend en charge la fonction de sortie audio numérique
	Connecteur d'entrée S/PDIF	x1	Prend en charge la fonction d'entrée audio numérique
	Embase de ventilateur UC	x1	Alimentation électrique du ventilateur UC (avec fonction de ventilateur intelligent)
	Embase de ventilateur système	x2	Alimentation électrique du ventilateur système
	Embase d'effacement CMOS	x1	
	Connecteur USB	x3	Chaque connecteur prend en charge 2 ports USB de panneau avant
	Connecteur d'alimentation (24 broches)	x1	
	Connecteur d'alimentation (8 broches)	x1	
Connecteur d'alimentation (4 broches)	x1		
E/S du panneau arrière	Clavier PS/2	x1	
	Souris PS/2	x1	
	Port LAN	x1	
	Port USB	x6	
	Fiche audio	x6	
	Port eSATA	x2	
Dimensions de la carte	244 mm (l) X 305 mm (H)	ATX	
Support SE	Windows 2000 / XP / VISTA		Biostar se réserve le droit d'ajouter ou de supprimer le support de SE avec ou sans préavis.

**ITALIAN**

<b>SPECIFICA</b>		
CPU	LGA 775 Processore Intel Core2Duo / Core2Quad / Pentium Dual-Core / Celeron Dual-Core / Celeron 4xx	Supporto di Execute Disable Bit / Enhanced Intel SpeedStep® / Architettura Intel 64 / Tecnologia Extended Memory 64 / Tecnologia Virtualization
FSB	800 / 1066 / 1333 / 1600 MHz	
Chipset	Intel P45 Intel ICH10R	
Super I/O	Fintek F71887F Fornisce le funzionalità legacy Super I/O usate più comunemente. Interfaccia LPC (Low Pin Count)	Funzioni di controllo dell'ambiente: Monitoraggio hardware Controller / Monitoraggio velocità ventolina Funzione "Smart Guardian" di ITE
Memoria principale	Alloggi DIMM DDR2 x 4 Ciascun DIMM supporta DDR2 256MB / 512MB / 1GB / 2GB Capacità massima della memoria 8GB	Modulo di memoria DDR2 a canale doppio Supporto di DDR2 1066 / 800 / 667 DIMM registrati e DIMM ECC non sono supportati
IDE	Marvell 88SE6121	Modalità Bus Master Ultra DMA 33 / 66 / 100 / 133 Supporto modalità PIO Mode 0-4
SATA II	ICH10R	Velocità di trasferimento dei dati fino a 3 Gb/s. Compatibile specifiche SATA Versione 2.0. Supporto RAID 0 / 1 / 5 / 1+0
eSATA	Marvell 88SE6121	Velocità di trasferimento dei dati fino a 3 Gb/s. Compatibile specifiche SATA Versione 2.0. Supporto Port-Multiplier/RAID 0,1
LAN	Realtek RTL 8111C	Negoziazione automatica 10 / 100 / 1000 Mb/s Capacità Half / Full Duplex
Supporto audio HD	ALC888S	Supporto audio High-Definition (HD) Uscita audio 7.1 canali
Alloggi	Alloggio PCI x2 Alloggio PCI Express Gen2 x16 (x16/x8) x1 Alloggio PCI Express Gen2 x16 (x8) x1 Alloggio PCI Express x1 x2	

<b>SPECIFICA</b>			
Connettori su scheda	Connettore floppy	x1	Ciascun connettore supporta 2 unità Floppy
	Porta seriale	x1	
	Connettore IDE	x1	Ciascun connettore supporta 2 unità IDE
	Connettore SATA	x6	Ciascun connettore supporta 1 unità SATA
	Connettore pannello frontale	x1	Supporta i servizi del pannello frontale
	Connettore audio frontale	x1	Supporta la funzione audio pannello frontale
	Connettore CD-in	x1	Supporta la funzione input audio CD
	Connettore output SPDIF	x2	Supporta la funzione d'output audio digitale
	Connettore input S/PDIF	x1	Supporta la funzione d'input audio digitale
	Collettore ventolina CPU	x1	Alimentazione ventolina CPU (con funzione Smart Fan)
	Collettore ventolina sistema	x2	Alimentazione ventolina di sistema
	Collettore cancellazione CMOS	x1	
	Connettore USB	x3	Ciascun connettore supporta 2 porte USB pannello frontale
Connettore alimentazione (24 pin)	x1		
Connettore alimentazione (8 pin)	x1		
Connettore alimentazione (4 pin)	x1		
I/O pannello posteriore	Tastiera PS/2	x1	
	Mouse PS/2	x1	
	Porta LAN	x1	
	Porta USB	x6	
	Connettore audio	x6	
Porta eSATA	x2		
Dimensioni scheda	244 mm (larghezza) x 305 mm (altezza)	ATX	
Sistemi operativi supportati	Windows 2000 / XP / VISTA	Biostar si riserva il diritto di aggiungere o rimuovere il supporto di qualsiasi sistema operativo senza preavviso.	

**SPANISH**

<i>Especificación</i>		
CPU	LGA 775 Procesador Intel Core2Duo / Core2Quad / Pentium Dual-Core / Celeron Dual-Core / Celeron 4xx	Admite Bit de deshabilitación de ejecución / Intel SpeedStep® Mejorado / Intel Architecture-64 / Tecnología Extended Memory 64 / Tecnología de virtualización
FSB	800 / 1066 / 1333 / 1600 MHz	
Conjunto de chips	Intel P45 Intel ICH10R	
Súper E/S	Fintek F71887F Le ofrece las funcionalidades heredadas de uso más común Súper E/S. Interfaz de cuenta Low Pin	Iniciativas de control de entorno, Monitor hardware Controlador/monitor de velocidad de ventilador Función "Guardia inteligente" de ITE
Memoria principal	Ranuras DIMM DDR2 x 4 Cada DIMM admite DDR de 256MB / 512MB / 1GB / 2GB Capacidad máxima de memoria de 8GB	Módulo de memoria DDR2 de canal Doble Admite DDR2 de 1066 / 800 / 667 No admite DIMM registrados o DIMM compatibles con ECC
IDE	Marvell 88SE6121	Modo bus maestro Ultra DMA 33 / 66 / 100 / 133 Soporte los Modos PIO 0~4,
SATA II	ICH10R	Tasas de transferencia de hasta 3 Gb/s. Compatible con la versión SATA 2.0. Admite RAID 0 / 1 / 5 / 1+0
eSATA	Marvell 88SE6121	Tasas de transferencia de hasta 3 Gb/s. Compatible con la versión SATA 2.0. Admite Port-Multiplier/RAID 0,1
Red Local	Realtek RTL 8111C	Negociación de 10 / 100 / 1000 Mb/s Funciones Half / Full dúplex
Soporte de sonido HD	ALC888S	Soporte de sonido de Alta Definición Salida de sonido de 7.1 canales
Ranuras	Ranura PCI X2 Ranura PCI Express Gen2 x16 (x16/x8) X1 Ranura PCI Express Gen2 x16 (x8) X1 Ranura PCI Express x1 X2	

<b>Especificación</b>			
Conectores en placa	Conector disco flexible	X1	Cada conector soporta 2 unidades de disco flexible
	Puerto serie	X1	
	Conector IDE	X1	Cada conector soporta 2 dispositivos IDE
	Conector SATA	X6	Cada conector soporta 1 dispositivos SATA
	Conector de panel frontal	X1	Soporta instalaciones en el panel frontal
	Conector de sonido frontal	X1	Soporta funciones de sonido en el panel frontal
	Conector de entrada de CD	X1	Soporta función de entrada de sonido de CD
	Conector de salida S/PDIF	X2	Soporta función de salida de sonido digital
	Conector de entrada S/PDIF	X1	Soporta función de entrada de sonido digital
	Cabecera de ventilador de CPU	X1	Fuente de alimentación de ventilador de CPU (con función Smart Fan)
	Cabecera de ventilador de sistema	X2	Fuente de alimentación de ventilador de sistema
	Cabecera de borrado de CMOS	X1	
	Conector USB	X3	Cada conector soporta 2 puertos USB frontales
Conector de alimentación (24 patillas)	X1		
Conector de alimentación (8 patillas)	X1		
Conector de alimentación (4 patillas)	X1		
Panel trasero de E/S	Teclado PS/2	X1	
	Ratón PS/2	X1	
	Puerto de red local	X1	
	Puerto USB	X6	
	Conector de sonido	X6	
	Puerto eSATA	X2	
Tamaño de la placa	244 mm. (A) X 305 Mm. (H)	ATX	
Soporte de sistema operativo	Windows 2000 / XP / VISTA		Biostar se reserva el derecho de añadir o retirar el soporte de cualquier SO con o sin aviso previo.

**PORTUGUESE**

<b>ESPECIFICAÇÕES</b>		
CPU	LGA 775 Processador Intel Core2Duo / Core2Quad / Pentium Dual-Core / Celeron Dual-Core / Celeron 4xx	Suporta as tecnologias Execute Disable Bit / Enhanced Intel SpeedStep® / Intel Architecture -64 / Extended Memory 64 / Virtualization
FSB	800 / 1066 / 1333 / 1600 MHz	
Chipset	Intel P45 Intel ICH10R	
Especificação do Super I/O	Fintek F71887F Proporciona as funcionalidades mais utilizadas em termos da especificação Super I/O. Interface LPC (Low Pin Count).	Iniciativas para controlo do ambiente Monitorização do hardware Controlador/Monitor da velocidade da ventoinha Função "Smart Guardian" da ITE
Memória principal	Ranuras DIMM DDR2 x 4 Cada módulo DIMM suporta uma memória DDR2 de 256 MB / 512 MB / 1GB / 2GB Capacidade máxima de memória:8 GB	Módulo de memória DDR2 de canal duplo Suporta módulos DDR2 1066 / 800 / 667 Os módulos DIMM registados e os DIMM ECC não são suportados
IDE	Marvell 88SE6121	Modo Bus master Ultra DMA 33 / 66 / 100 / 133 Suporta o modo PIO 0~4,
SATA II	ICH10R	Velocidades de transmissão de dados até 3 Gb/s. Compatibilidade com a especificação SATA versão 2.0. Suporta as funções RAID 0 / 1 / 5 / 1+0
eSATA	Marvell 88SE6121	Velocidades de transmissão de dados até 3 Gb/s. Compatibilidade com a especificação SATA versão 2.0. Suporta as funções Port-Multiplier/RAID 0,1
LAN	Realtek RTL 8111C	Auto negociação de 10 / 100 / 1000 Mb/s Capacidade semi/full-duplex
Suporte para áudio de alta definição	ALC888S	Suporta a especificação High-Definition Audio Saída de áudio de 7.1 canais
Ranuras	Ranhura PCI x2 Ranhura PCI Express Gen2 x16 (x16/x8) x1 Ranhura PCI Express Gen2 x16 (x8) x1 Ranhura PCI Express x1 x2	

<b>ESPECIFICAÇÕES</b>			
Conectores na placa	Conector da unidade de disquetes	x1	Cada conector suporta 2 unidades de disquetes
	Porta série	x1	
	Conector IDE	x1	Cada conector suporta 2 dispositivos IDE
	Conector SATA	x6	Cada conector suporta 1 dispositivo SATA
	Conector do painel frontal	x1	Para suporte de várias funções no painel frontal
	Conector de áudio frontal	x1	Suporta a função de áudio no painel frontal
	Conector para entrada de CDs	x1	Suporta a entrada de áudio a partir de CDs
	Conector de saída S/PDIF	x2	Suporta a saída de áudio digital
	Conector de entrada S/PDIF	x1	Suporta a entrada de áudio digital
	Conector da ventoinha da CPU	x1	Alimentação da ventoinha da CPU (com a função Smart Fan)
	Conector da ventoinha do sistema	x2	Alimentação da ventoinha do sistema
	Conector para limpeza do CMOS	x1	
	Conector USB	x3	Cada conector suporta 2 portas USB no painel frontal
Conector de alimentação (24 pinos)	x1		
Conector de alimentação (8 pinos)	x1		
Conector de alimentação (4 pinos)	x1		
Entradas/Saídas no painel traseiro	Teclado PS/2	x1	
	Rato PS/2	x1	
	Porta LAN	x1	
	Porta USB	x6	
	Tomada de áudio	x6	
	Porta eSATA	x2	
Tamanho da placa	244 mm (L) X 305 mm (A)		ATX
Sistemas operativos suportados	Windows 2000 / XP / VISTA		A Biostar reserva-se o direito de adicionar ou remover suporte para qualquer sistema operativo com ou sem aviso prévio.

**POLISH**

<i>SPEC</i>		
Procesor	LGA 775 Procesor Intel Core2Duo / Core2Quad / Pentium Dual-Core / Celeron Dual-Core / Celeron 4xx	Obsługa Execute Disable Bit / Enhanced Intel SpeedStep® / Intel Architecture-64 / Extended Memory 64 Technology / Virtualization Technology
FSB	800 / 1066 / 1333 / 1600 MHz	
Chipset	Intel P45 Intel ICH10R	
Pamięć główna	Gniazda DDR2 DIMM x 4 Każde gniazdo DIMM obsługuje moduły 256MB / 512MB / 1GB / 2GB Maks. wielkość pamięci 8GB	Moduł pamięci DDR2 z trybem podwójnego kanału Obsługa DDR2 1066 / 800 / 667 Brak obsługi Registered DIMM oraz ECC DIMM
Super I/O	Fintek F71887F Zapewnia najbardziej powszechne funkcje Super I/O. Interfejs Low Pin Count	Funkcje kontroli warunków pracy, Monitor H/W Kontroler/Monitor prędkości wentylatora Funkcja ITE "Smart Guardian"
IDE	Marvell 88SE6121	Ultra DMA 33 / 66 / 100 / 133 Tryb Bus Master obsługa PIO tryb 0~4,
SATA II	ICH10R	Transfer danych do 3 Gb/s. Zgodność ze specyfikacją SATA w wersji 2.0. Obsługa RAID 0 / 1 / 5 / 1+0
eSATA	Marvell 88SE6121	Transfer danych do 3 Gb/s. Zgodność ze specyfikacją SATA w wersji 2.0. Obsługa Port-Multiplier/RAID 0,1
LAN	Realtek RTL 8111C	10 / 100 / 1000 Mb/s z automatyczną negocjacją szybkości Działanie w trybie połowicznego / pełnego duplexu
Obsługa audio HD	ALC888S	Obsługa High-Definition Audio 7.1 kanałowe wyjście audio
Gniazda	Gniazdo PCI x2 Gniazdo PCI Express Gen2 x16 (x16/x8) x1 Gniazdo PCI Express Gen2 x16 (x8) x1 Gniazdo PCI Express x1 x2	



<b>SPEC</b>			
Złącza wbudowane	Złącze napędu dyskietek	x1	Każde złącze obsługuje 2 napędy dyskietek
	Port szeregowy	x1	
	Złącze IDE	x1	Każde złącze obsługuje 2 urządzenia IDE
	Złącze SATA	x6	Każde złącze obsługuje 1 urządzenie SATA
	Złącze panela przedniego	x1	Obsługa elementów panela przedniego
	Przednie złącze audio	x1	Obsługa funkcji audio na panelu przednim
	Złącze wejścia CD	x1	Obsługa funkcji wejścia audio CD
	Złącze wyjścia S/PDIF	x2	Obsługa funkcji cyfrowego wyjścia audio
	Złącze wejścia S/PDIF	x1	Obsługa funkcji cyfrowego wejścia audio
	Złącze główkowe wentylatora procesora	x1	Zasilanie wentylatora procesora (z funkcją Smart Fan)
	Złącze główkowe wentylatora systemowego	x2	Zasilanie wentylatora systemowego
	Złącze główkowe kasowania CMOS	x1	
	Złącze USB	x3	Każde złącze obsługuje 2 porty USB na panelu przednim
	Złącze zasilania (24 pinowe)	x1	
	Złącze zasilania (8 pinowe)	x1	
Złącze zasilania (4 pinowe)	x1		
Back Panel I/O	Klawiatura PS/2	x1	
	Mysz PS/2	x1	
	Port LAN	x1	
	Port USB	x6	
	Gniazdo audio	x6	
	Port eSATA	x2	
Wymiary płyty	244 mm (S) X 305 mm (W)		ATX
Obsługa systemu operacyjnego	Windows 2000 / XP / VISTA		Biostar zastrzega sobie prawo dodawania lub odwoływania obsługi dowolnego systemu operacyjnego bez powiadomienia.

**RUSSIAN**

<b>СПЕЦ</b>		
CPU (центральный процессор)	LGA 775 Процессор Intel Core2Duo / Core2Quad / Pentium Dual-Core / Celeron Dual-Core / Celeron 4xx	Поддержка технологий Execute Disable Bit / Enhanced Intel SpeedStep® / Intel Architecture-64 / Extended Memory 64 Technology / технологии виртуализация
FSB	800 / 1066 / 1333 / 1600 МГц	
Набор микросхем	Intel P45 Intel ICH10R	
Основная память	Слоты DDR2 DIMM x 4 Каждый модуль DIMM поддерживает 256 МБ / 512МБ / 1ГБ / 2ГБ DDR2 Максимальная ёмкость памяти 8ГБ	Модуль памяти с двухканальным режимом DDR2 Поддержка DDR2 1066 / 800 / 667 Не поддерживает зарегистрированные модули DIMM and ECC DIMM
Super I/O	Fintek F71887F Обеспечивает наиболее используемые действующие функциональные возможности Super I/O. Интерфейс с низким количеством выводов	Инициативы по охране окружающей среды, Аппаратный монитор Регулятор скорости вентилятора/ монитор Функция ITE "Smart Guardian" (Интеллектуальная защита)
IDE	Marvell 88SE6121	Режим "хозяина" шины Ultra DMA 33 / 66 / 100 / 133 Поддержка режима PIO 0~4,
SATA II	ICH10R	скорость передачи данных до 3 гигабит/с. Соответствие спецификации SATA версия 2.0. Поддержка RAID 0 / 1 / 5 / 1+0
eSATA	Marvell 88SE6121	скорость передачи данных до 3 гигабит/с. Соответствие спецификации SATA версия 2.0. Поддержка Port-Multiplier/RAID 0,1
Локальная сеть	Realtek RTL 8111C	Автоматическое согласование 10 / 100 / 1000 Мб/с Частичная / полная дуплексная способность
Звуковая поддержка жесткого диска	ALC888S	Звуковая поддержка High-Definition 7.1канальный звуковой выход
Слоты	Слот PCI x2 Слот PCI Express Gen2 x16 (x16/x8) x1 Слот PCI Express Gen2 x16 (x8) x1 Слот PCI Express x1 x2	

СПЕЦ			
Встроенны й разъём	Разъём НГМД	x1	Каждый разъём поддерживает 2 накопителя на гибких магнитных дисках
	Последовательный порт	x1	
	Разъём IDE	x1	Каждый разъём поддерживает 2 встроенных интерфейса накопителей
	Разъём SATA	x6	
	Разъём на лицевой панели	x1	Поддержка устройств на лицевой панели
	Входной звуковой разъём	x1	
	Разъём ввода для CD	x1	Поддержка функции ввода для CD
	Разъём вывода для S/PDIF	x2	
	Разъём ввода для S/PDIF	x1	Поддержка вывода цифровой звуковой функции
	Контактирующее приспособление вентилятора центрального процессора	x1	
	Контактирующее приспособление вентилятора системы	x2	Источник питания для вентилятора центрального процессора (с функцией интеллектуального вентилятора)
	Открытое контактирующее приспособление CMOS	x1	
	USB-разъём	x3	Каждый разъём поддерживает 2 USB-порта на лицевой панели
	Разъём питания (24 вывод)	x1	
Разъём питания (8 вывод)	x1		
	Разъём питания (4 вывод)	x1	
Задняя панель средств ввода-выв ода	Клавиатура PS/2	x1	
	Мышь PS/2	x1	
	Порт LAN	x1	
	USB-порт	x6	
	Гнездо для подключения наушников	x6	
	eSATA порт	x2	
Размер панели	244 мм (Ш) X 305 мм (В)		ATX
Поддержка OS	Windows 2000 / XP / VISTA		Biostar сохраняет за собой право добавлять или удалять средства обеспечения для OS с или без предварительного уведомления.

## ARABIC

المواصفات		
Execute Disable Bit / Enhanced Intel SpeedStep® / Intel Architecture-64 / Extended Memory 64 Technology / Virtualization Technology	LGA 775 Intel Core2Duo / Core2Quad / Pentium Dual-Core / Celeron Dual-Core / Celeron 4xx	وحدة المعالجة المركزية يتردد يصل إلى
	800 / 1066 / 1333 / 1600	ميجا هرتز تردد
	Intel P45 Intel ICH10R	مجموعة الشرائح
مزدوجة القناة DDR2 وحدة ذاكرة سعة 1066 / 800 / 667 ميجا بليت DDR2 تدعم الذاكرة من نوع ECC وتلك التي لا تتوافق مع DIMM لا تدعم رفلق الذاكرة	عدد 4 قناة DDR2 DIMM ميجا 256/512 سعة DDR2 تدعم ذاكرة من نوع DIMM كل قناة بليت 2 و بليت 1 جيجا بليت سعة ذاكرة قصوى 8 جيجا بليت	الذاكرة الرئيسية
وسائل التحكم في البيئة: مراقب لمعرفة حالة الأجهزة مراقب في سرعة المروحة ITE من "Smart Guardian" ووظيفة	Fintek F71887F الأكثر استخداماً. Super I/O ووفر وظيفة Low Pin Count Interface تدعم تقنية	Super I/O
وضع رئيسي Ultra DMA 33 / 66 / 100 / 133 نقل بتقنية PIO Mode 0~4 دعم وضع	Marvell 88SE6121	منفذ IDE
نقل البليت بسرعة تصل إلى 3 جيجابت/ثانية. الإصدار SATA مطابقة لمواصفات RAID 0 / 1 / 5 / 1+0 تدعم تقنية	ICH10R	SATA II
نقل البليت بسرعة تصل إلى 3 جيجابت/ثانية. الإصدار SATA مطابقة لمواصفات RAID 0,1 /Port-Multiplier تدعم تقنية	Marvell 88SE6121	eSATA
تفاوض تلقائي 100/10 ميجا بليت / ثانية و 1 جيجا بليت/ثانية إمكانية النقل المزدوج الكامل/النصفي	Realtek RTL 8111C	شبكة داخلية
تدعم تقنية الصوت عالي التعريف من 7.1 قنوات لخرج الصوت	ALC888S	دعم الصوت عالي التعريف
	عدد 2 قناة PCI Express Gen2 x16 (x8/x8) عدد 1 قناة PCI Express Gen2 x16 (x8) عدد 2 قناة PCI Express x1	القنوات

المواصفات		
منفذ محرك أقراص مرنة	عدد 1	منفذ محرك أقراص مرنة
منفذ تسلسلي	عدد 1	منفذ تسلسلي
منفذ IDE	عدد 1	منفذ IDE
منفذ SATA يدعم كل منفذ واحد من أجهزة SATA	عدد 6	منفذ SATA
منفذ اللوحة الأمامية	عدد 1	منفذ اللوحة الأمامية
منفذ الصوت الأمامي	عدد 1	منفذ الصوت الأمامي
منفذ CD-IN	عدد 1	منفذ CD-IN
منفذ خرج S/PDIF	عدد 2	منفذ خرج S/PDIF
منفذ دخل S/PDIF	عدد 1	منفذ دخل S/PDIF
وصلة مروحة وحدة المعالجة المركزية	عدد 1	وصلة مروحة وحدة المعالجة المركزية
وصلة مروحة النظام	عدد 2	وصلة مروحة النظام
وصلة مسح CMOS	عدد 1	وصلة مسح CMOS
منفذ USB	عدد 3	منفذ USB
منفذ توصيل الطاقة (24 دبوس)	عدد 1	منفذ توصيل الطاقة (24 دبوس)
منفذ توصيل الطاقة (8 دبوس)	عدد 1	منفذ توصيل الطاقة (8 دبوس)
منفذ توصيل الطاقة (4 دبوس)	عدد 1	منفذ توصيل الطاقة (4 دبوس)
لوحة مفاتيح PS/2	عدد 1	لوحة مفاتيح PS/2
ملوس PS/2	عدد 1	ملوس PS/2
منفذ شبكة اتصال محلية	عدد 1	منفذ شبكة اتصال محلية
منافذ USB	عدد 6	منافذ USB
مقيس صوت	عدد 6	مقيس صوت
منفذ eSATA	عدد 2	منفذ eSATA
حجم اللوحة	244 مم (عرض) X 305 مم (الارتفاع)	حجم اللوحة
دعم أنظمة التشغيل	Windows 2000 / XP / VISTA	دعم أنظمة التشغيل
احتفظ بـ Biostar	بحقها في إضافة أو إزالة الدعم لأي نظام تشغيل بلخطار Biostar احتفظ أو بدون إخطار .	

**JAPANESE**

仕様		
CPU	LGA 775 Intel Core2Duo / Core2Quad / Pentium Dual-Core / Celeron Dual-Core / Celeron 4xx processor	Execute Disable Bit / Enhanced Intel SpeedStep® / Intel Architecture-64 / Extended Memory 64 Technology / Virtualization Technologyをサポートします
FSB	800 / 1066 / 1333 / 1600 MHz	
チップセット	Intel P45 Intel ICH10R	
メインメモリ	DDR2 DIMMスロット x 4 各DIMMは 256MB / 512MB / 1GB / 2GB DDR2をサポート 最大メモリ容量8GB	デュアル チャンネルモードDDR2 メモリモジュール DDR2 1066 / 800 / 667をサポート 登録済みDIMMとECC DIMMはサポートされません
Super I/O	Fintek F71887F もつとも一般に使用されるレガシーSuper I/O 機能を採用しています。 低ピンカウントインターフェイス	環境コントロールイニシアチブ、 H/Wモニター ファン速度コントローラ/ モニター ITEの「スマートガーディアン」機能
IDE	Marvell 88SE6121	Ultra DMA 33 / 66 / 100 / 133バスマスタモード PIO Mode 0~4のサポート
SATA II	ICH10R	最高3 Gb/秒のデータ転送速度 SATAバージョン2.0仕様に準拠。 RAID 0 / 1 / 5 / 1+0のサポート
eSATA	Marvell 88SE6121	最高3 Gb/秒のデータ転送速度 SATAバージョン2.0仕様に準拠。 RAID 0,1 /Port-Multiplierのサポート
LAN	Realtek RTL 8111C	10 / 100 / 1000 Mb/秒のオートネゴシエーション 半/全二重機能
HDオーディオのサポート	ALC888S	ハイデフィニションオーディオのサポート 7.1 チャンネルオーディオアウト
スロット	PCIスロット x2 PCI Express Gen2 x16スロット (x16/x8) x1 PCI Express Gen2 x16スロット (x8) x1 PCI Express x1スロット x2	

仕様			
オンボードコネクタ	フロッピーコネクタ	x1	各コネクタは2つのフロッピードライブをサポートします
	シリアルポート	x1	
	IDEコネクタ	x1	各コネクタは2つのIDEデバイスをサポートします
	SATAコネクタ	x6	各コネクタは1つのSATAデバイスをサポートします
	フロントパネルコネクタ	x1	フロントパネル機能をサポートします
	フロントオーディオコネクタ	x1	フロントパネルオーディオ機能をサポートします
	CDインコネクタ	x1	CDオーディオイン機能をサポートします
	S/PDIFアウトコネクタ	x2	デジタルオーディオアウト機能をサポートします
	S/PDIFインコネクタ	x1	デジタルオーディオイン機能をサポートします
	CPUファンヘッダ	x1	CPUファン電源装置(スマートファン機能を搭載)
	システムファンヘッダ	x2	システムファン電源装置
	CMOSクリアヘッダ	x1	
	USBコネクタ	x3	各コネクタは2つのフロントパネルUSBポートをサポートします
電源コネクタ(24ピン)	x1		
電源コネクタ(8ピン)	x1		
電源コネクタ(4ピン)	x1		
背面パネル I/O	PS/2キーボード	x1	
	PS/2マウス	x1	
	LANポート	x1	
	USBポート	x6	
	オーディオジャック	x6	
	eSATAポート	x2	
ボードサイズ	244 mm (幅) X 305 mm (高さ)	ATX	
OSサポート	Windows 2000 / XP / VISTA		Biostarは事前のサポートなしにOSサポートを追加または削除する権利を留保します。

2008/04/23