



Disposal Instruction (US)

For better protection of our earth, please don't throw this electronic device into municipal trash bin when discarding. To minimize pollution and ensure utmost protection of the global environment, please recycle the product. For more information about the collection and recycling of Waste Electrical and Electronic Equipment (WEEE), you are invited to visit our homepage at www.aopen.com under "Green Products"

廃棄上の指示

より良い地球保護のために、電子機器を廃棄処分にする時は、ゴミ箱に捨てないで下さい。汚染を最小限に抑え、地球環境の最大限の保護のために、製品をリサイクルして下さい。廃電気電子機器（WEEE）の回収とリサイクルについての情報は、弊社ホームページwww.aopen.comの“Green Products”（環境に優しい製品）をご覧ください。

廢棄及回收處理

為了保護環境，請勿將本產品當作一般廢棄物處理。為減少環境污染，維護地球資源，本產品報廢時，請回收本產品。

Instruktion til bortskaffelse (Danish)

Af hensyn til vores miljø bedes De ikke bortskaffe denne elektroniske enhed i en almindelig affaldsspand. For at mindske forurening og sikre beskyttelse af miljøet bedes De genbruge produktet. For yderligere information vedrørende indsamling og genbrug af elektronik-affald (Waste Electrical and Electronic Equipment (WEEE)) er De velkommen til at besøge vores website www.aopen.com og læse nærmere under "Green Products".

Verwijderingsinstructie (Dutch)

Om mogelijke schade aan het milieu of de menselijke gezondheid door ongecontroleerde afvalverwijdering te voorkomen, moet u dit elektronisch product scheiden van andere soorten afval en op een verantwoorde manier recyclen. Verwijder dit product dan ook alstublieft niet samen met ander huishoudelijk afval. Voor meer informatie over de verzameling en recycling van elektrisch afval en elektronische apparatuur (WEEE), nodigen we u uit om onze homepage te bezoeken www.aopen.com onder "Green Products".

Instruction de Disposition (French)

Pour une meilleure protection de la terre, ne jetez pas ce dispositif électronique dans la poubelle municipale lors de la disposition. Pour éliminer la pollution et assurer la plus grande protection de l'environnement global, réutilisez s'il vous plaît le produit. Pour plus d'informations sur la gestion des déchets d'Equipements Electriques et Electroniques (DEEE ou WEEE), vous êtes invité à visiter notre site à www.aopen.com sous " Green Products".

Entsorgungsanleitung (German)

Zum besseren Schutze unseres Planeten, schmeissen Sie elektrische Geräte bitte nicht in öffentliche Mülleimer. Zur Verringerung der Verschmutzung und zur Sicherstellung grösstmöglichen Schutzes der Umwelt recyceln Sie bitte das Produkt. Für mehr Informationen zum Sammeln und Recyceln von elektrischen und elektronischen Müll (WEEE) besuchen Sie bitte unsere Homepage unter www.aopen.com unter dem Punkt "Green Products".

Istruzioni per lo smaltimento (Italian)

Per una migliore salvaguardia del nostro pianeta, si prega di non gettare questo dispositivo elettronico nei normali rifiuti al momento dell'eliminazione. Per ridurre al minimo l'inquinamento ed assicurare la massima protezione dell'ambiente, si prega di riciclare il prodotto. Per maggiori informazioni riguardanti la raccolta ed il riciclaggio delle apparecchiature elettriche ed elettroniche residue (WEEE), siete invitati a visitare la nostra homepage www.aopen.com alla voce "Green Products".

Instruksjoner for Resirkulering og Oppsamling (Norwegian)

For å beskytte vår planet, kast ikke dette elektroniske utstyret sammen med vanlig avfall. For å beskytte vår natur og miljø, vennligst resirkuler dette produktet. For mer informasjon om oppsamling og resirkulering i henhold til Waste Electrical and Electronic Equipment (WEEE), se vår hjemmeside på www.aopen.com under "Green Products".

Programa de Tratamento de Resíduos de Equipamentos Eléctricos e Electrónicos (Portugese)

Para melhor protecção ambiental do nosso planeta terra, não coloque o dispositivo electrónico no receptáculo de lixo municipal. Para minimizar a poluição e garantir protecção máxima do ambiente global, recicle o produto. Para mais informações sobre acerca da recolha e reciclagem de Equipamento Eléctrico e Electrónico (WEEE), convidamos-lhe a visitar nossa página na Internet em www.aopen.com sobre "Green Products".

Instrucciones para depositar los productos electrónicos (Spanish)

Para proteger mejor el medio ambiente, por favor, no deposite los productos electrónicos en los contenedores de basura tradicionales. Para reducir la contaminación y proteger el medio ambiente se recomienda que los recicle. Para más información acerca de dónde depositar y cómo reciclar Equipos Electrónicos y Desperdicios Electrónicos (WEEE), por favor, visite la página web www.aopen.com y entre en la sección Productos Ecológicos ("Green Products").

Kassering (Swedish)

För att bättre värna om vår jord bör denna elektroniska utrustning ej kasseras tillsammans med vanligt avfall. För att minimera mängden föroreningar och så långt som möjligt skydda den globala miljön bör produkten återvinnas. För vidare information om insamling och återvinning av uttjänta elektriska och elektroniska produkter (Waste Electrical and Electronic Equipment, WEEE), besök avsnittet "Green Products" på vår hemsida, www.aopen.com.

Contents

Disposal Instructions	i
Welcome	1
Copyright © 2007 AOpen Inc. All Right Reserved	1
Notes and Warning labels used in the manual	2
Safety Information	2
Chapter 1 Introduction	3
1.1 Board and I/O Layout	3
1.2 Rear I/O Ports	4
1.3 System Block Diagram	5
Chapter 2 Hardware Installation	7
2.1 Installation Overview	7
2.2 Installing the CPU	8
2.3 Installing CPU Cooler	9
2.4 Installing CPU and System Fans	10
2.5 Installing System Memory Modules	11
2.6 Installing IDE Cable	12
2.7 Connecting Serial ATAII	13
2.8 Connecting Front Panel Cable	14
2.9 Power Consumption	15
2.10 Mini PCI and PCI x 1 Installation	17
2.11 Gigabit LAN	18
2.12 Connecting USB 2.0	19
2.13 Channel Audio	20
2.14 Connecting Front Audio	21
2.15 Connect CD_IN	22
2.16 Connecting COM2 Port	23
2.17 Connecting Case Open "Chassis Intrusion"	24
2.18 24 bits LVDS Connector (Option)	25
2.19 COM2 Port (Option)	26
2.20 JP14 Clear CMOS Jumper	27

Chapter 3 Setting the BIOS	29
3.1 Introduction	29
3.2 How to use the Phoenix-Award BIOS Setup Program	29
3.3 How to Enter the BIOS Setup	30
3.4 Standard CMOS Features	31
3.5 Advanced BIOS Features	33
3.6 Advanced Chipset Features	35
3.7 Integrated Peripherals	36
3.8 Power Management Setup	38
3.9 PC health status	39
3.10 Load Optimized Defaults	40
3.11 Set Password	41
3.12 Save & Exit Setup	42
3.13 Exit without saving	42
3.14 BIOS Upgrade under Windows Environment	43
Chapter 4 Installing Drivers	45
4.1 Driver Install Utility	45
4.2 Other useful Features	46
4.3 Useful Utilities	47
Chapter 5 Troubleshooting	48
Troubleshooting Steps	48
Chapter 6 Technical Support and Contact	49
AOpen Technical Support Team Global Locations	50
AOpen Technical Support	51

Welcome

First of all, we would like to express our gratitude for purchasing AOpen products. This motherboard is designed to meet all your personal needs with industry-leading features, the newest components and a strong focus on quality manufacturing and the testing and service that brings a positive computing experience that lasts for years.

This manual will introduce how this motherboard is installed. Please keep it well for your future reference. If you lose your printed manual, you may also go to our website at <http://www.aopen.com> to download an updated file in PDF format. Now, we would like to invite you to experience this user-friendly manual and all of the powerful functions this AOpen product offers.

Copyright © 2007 AOpen Inc. All Right Reserved

This document is based on the copyright laws in order to protect our company and reserve all rights. Under no circumstances are any types of duplicating and loading this brochure in any databases and media permitted without the express written permission of AOpen Inc.

Products and corporate names appearing in this manual may or may not be registered trademarks or copyrights of their respective companies, and are used only for identification or explanation and to the owners' benefit, without intent to infringe.

The logos of Adobe and Acrobat are the registered trademarks of Adobe Systems Incorporated.

The logos of AMD, Athlon, and Duron are the registered trademarks of Advanced Micro Devices, Inc.

The logos of Intel, Intel Celeron, Pentium II, III, Pentium 4, Pentium M and Core 2 Duo are the registered trademarks of Intel Corporation.

The logos of nVIDIA are the registered trademarks of nVIDIA Corporation.

The logos of Microsoft, Windows are the registered trademarks of Microsoft Corporation in America and other countries.

All the titles of the products and the trademarks mentioned in this manual are for the purpose of illustrative conveniences and are possessed by their respective firms.

We regret not informing about any changes in usage standards and other related information. AOpen reserves the right to alter or modify the content of this manual. In case of any mistakes or incorrect descriptions, which include those on the products, AOpen makes no guarantee or commitments.

Notes and Warning labels used in the manual

Please pay attention when you see the following symbols. They point out useful information for this motherboard and make users aware of certain conditions.

Warning: 	Please be careful when you see this mark. Can possibly injure yourself or the motherboard if you do not follow instructions.
--	--

Note: 	This contains knowledge you should know when assembling or using this AOpen product, or some helpful tip.
---	---

Tip: 	This Tip tells you some useful information that will make your installation go smoothly.
--	--

Caution: 	Highlights where mistakes often occur during assembly or use.
--	---

Safety Information

Warning: 	<ol style="list-style-type: none">1. Please wear a wrist strap and attach it to a metal part of the system unit before handling a component. You can also touch a metal object that has a ground connection or another metal surface.2. Always unplug the power before you make any jumper settings.3. Before you install or remove any components on the motherboard, please make sure to disconnect the power first to prevent damage to the motherboard or other components.
--	---

Chapter 1 Introduction

1.1 Board and I/O Layout

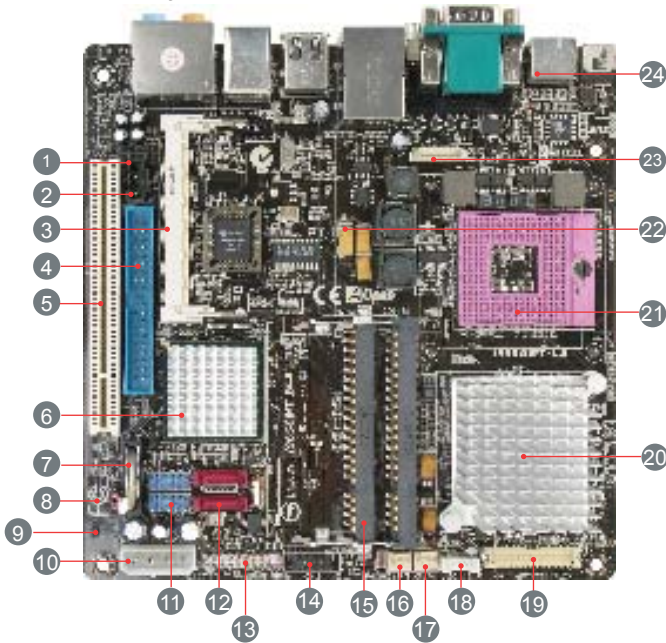

Table 1.1 Board Components

Item	Item
01. Front Audio Connector	14. COM2 Connector
02. CD Audio in Connector	15. 200-pin SO-DIMM x 2, support DDRII 533/667 MHz
03. Mini PCI slot	16. System Fan Connector
04. IDE Connector	17. CPU Fan Connector
05. PCI Slot	18. LVDS_INV Connector (Option)
06. Intel ICH8M chipset	19. 24 bits LVDS Connector (Option)
07. Battery	20. Intel GM965 Chipset
08. JP14 CMOS clear jumper	21. Socket P support Intel Core 2 Extreme Core 2 Duo (Merom) processor.
09. Case Open Connector	22. Stand by LED
10. 4-pin DC Power Output Connector	23. VGA2 Connector (Option)
11. USB 2.0 Connector x 2	24. Chrontel 7307C DVI DEC (i965GMt-LA)
12. SATA II Connector x 2	25. Chrontel 7307 DVI + LVDS DEL (Option)
13. Front Panel Connector	

1.2 Rear I/O Ports

Figure 1.1 Board I/O Layout

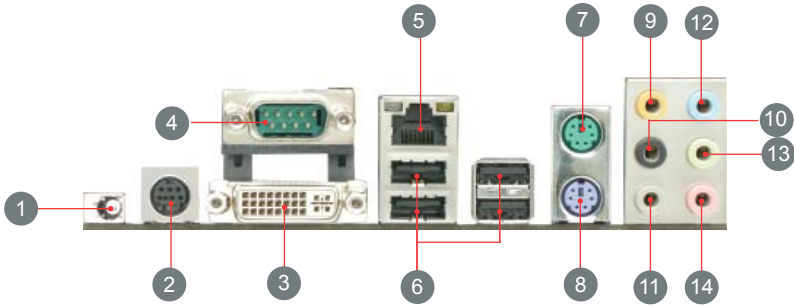

Table 1.2: Real I/O

Item	Item
01. 19V DC Adapter Connector	08. PS/2 Keyboard Connector
02. S-Video Out Connector	09. Rear Surround (S/PDIF_Out)
03. DVI Port	10. Center/Subwoofer
04. COM1 Port	11. Side Surround
05. RJ45 LAN Port	12. Line-In (S/PDIF_In)
06. USB 2.0 Port x 4	13. Speaker Out
07. PS/2 Mouse Connector	14. Mic-In

Table 1.3: i965GMt-LA Specifications

Model	i965GMt-LA
CPU	Core 2 Duo / Celeron Processor FSB 533 / 667 / 800 MHz
Chipset	Intel® GM965 / ICH8M
Main Memory	Dual Channel Mode Support SO-DIMM DDRII 533 / 667 MHz DDRII SO-DIMM x 2 DIMM Type : 256 / 512MB / 1GB / 2GB Max Memory : 4GB
Graphics	Integrated Intel® GMA X3100 (Graphics Media Accelerator) in Chipset
Storage	Integrated Serial ATA and ATA 100 Controller
LAN	Integrated Realtek Gigabit PCI LAN Controller
Sound	Intel High Definition Audio on-board Support 7.1 Channel and above
USB	Integrated in Chipset, USB 2.0 x 8
Slots	PCI Slot x 1 Mini PCI x 1
Back Panel I/O	Power DC-in Jack x 1 PS/2 Keyboard x 1, PS/2 Mouse x 1 DVI Port x 1, COM Port x 1, S-Video Out Port x 1 USB Port x 4, LAN Port x 1, Speaker_Out x 1, Line_In (S/PDIF_In) x 1, Mic_In x 1 Side Surround x 1, Rear Surround (S/PDIF_Out) x 1, Center/Subwoofer x 1
On-Board Connector	4-pin Power Output Connector for HDD / ODD IDE Connector x 1 Serial ATA II Channel x 2 Front Panel Connector x 1 Front Audio Connector x 1 CPU FAN Connector x 1, System FAN Connector x 1 Case Open Connector x 1 CD_IN Connector x 1 COM Connector x 1 USB 2.0 Connector x 2 (Support USB Port x4) LVDS_INV Connector (Option) 24 bits LVDS Connector (Option) VGA2 Connector (Option)
BIOS	Award PnP 4Mb Flash ROM BIOS
Board Size	170 mm x 170 mm

Note:

1. Specifications are subject to change without notice.
2. Max Memory: 4GB, but can't be detected 4GB due Intel chipset limitation.

1.3 System Block Diagram

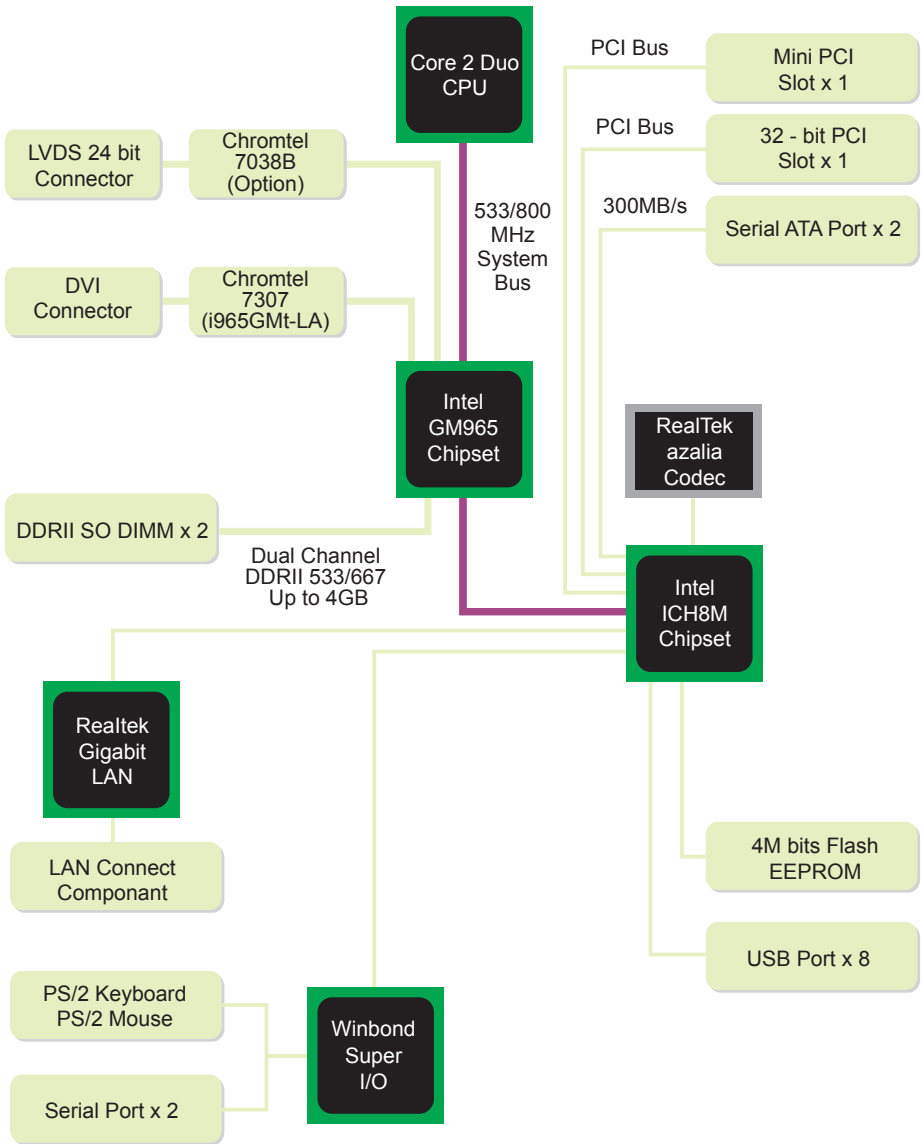

Chapter 2 Hardware Installation

2.1 Installation Overview

Generally, when installing a new motherboard and peripherals into a chassis, people typically follow a certain order of steps for the installation. The list below are the general steps:

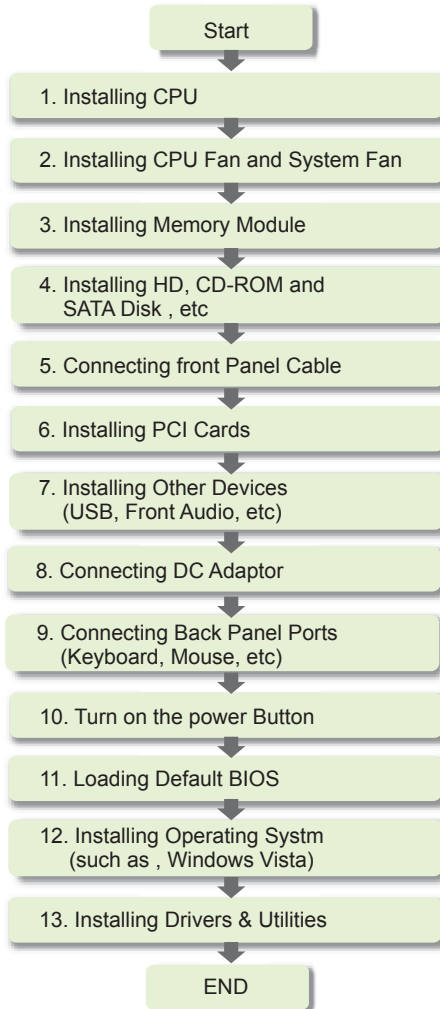

2.2 Installing the CPU

This socket supports uFCPGA package CPU, which is the latest CPU package developed by Intel. Other forms of CPU package are impossible to be fitted in.

1. Unscrew socket screw counter- clockwise.
2. Locate Pin 1 in the socket and look for a golden arrow on the CPU upper interface. Match Pin 1 and golden arrow. Then insert the CPU into the socket.
3. Lock the socket screw clockwise to fasten CPU.

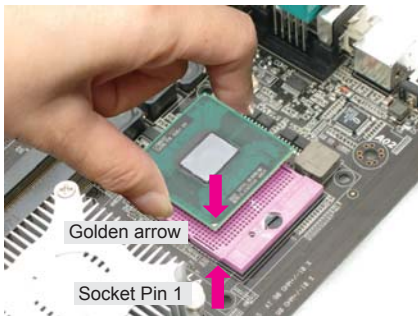
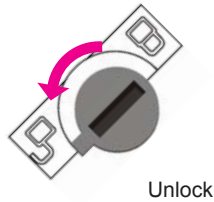
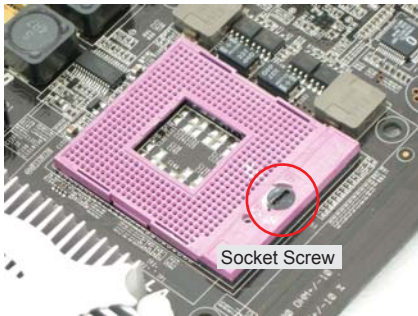

Warning:	If you do not match the CPU socket Pin 1 and CPU golden arrow well, you may damage the CPU.

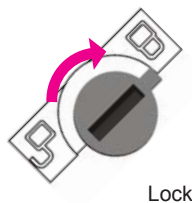
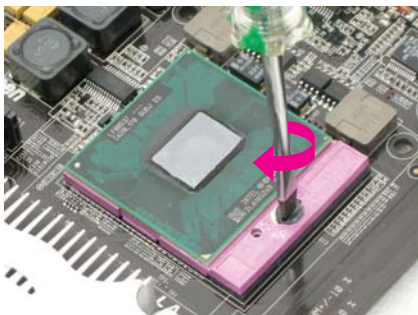

Support CPU Table

Processor Number	Architecture	Clock Speed	Front Side Bus	L2 Cache
Merom				
Core 2 Duo T7800	65nm	2.60 GHz	800 MHz	4MB
Core 2 Duo T7700	65nm	2.40 GHz	800 MHz	4MB
Core 2 Duo T7500	65nm	2.20 GHz	800 MHz	4MB
Core 2 Duo T7300	65nm	2.00 GHz	800 MHz	4MB
Core 2 Duo T7250	65nm	2.00 GHz	800 MHz	2MB
Core 2 Duo T7100	65nm	1.80 GHz	800 MHz	2MB
Celeron 550	65nm	2.00 GHz	533 MHz	1MB
Celeron 550	65nm	1.86 GHz	533 MHz	1MB
Celeron 550	65nm	1.73 GHz	533 MHz	1MB

* GM965 Support front side BUS 533MHz / 800MHz.

	<p>Note: With CPU speed changing rapidly, there may be faster CPU on the market by the time you received this installation guide. This table is kindly for your reference only.</p>
--	--

2.3 Installing CPU Cooler

1. Remove the four screws of the CPU heatsink and take the bracket from heatsink.
2. Tear off the label from bracket for easily pasted on the bottom of main board.
3. Place bracket properly on the back side as picture.
4. Smear over the thermal compound under the center of heatsink smoothly and let it be well mixed.
5. Please follow concave of direction on bottom of heatsink, Put the CPU Fan & heatsink on the processor and lock the four screws of the heatsink with bracket (on the MB back side). Please make sure the screws are well tied between the motherboard and heatsink.

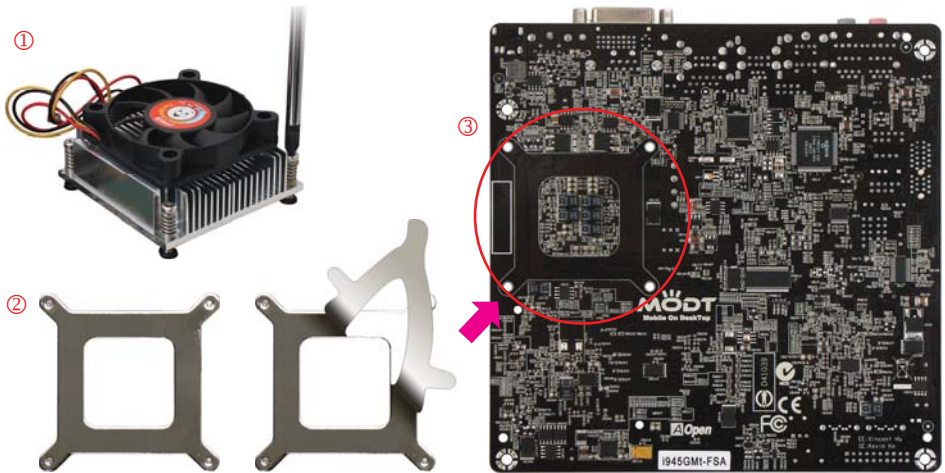

Warning:



Always use the correct amount of thermal grease when mounting the CPU cooler. Follow the instructions closely.

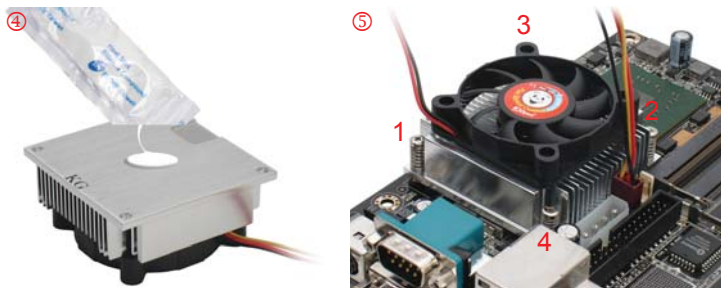

Note:



This cooler and picture shown might be different from your purchased product.

2.4 Installing CPU and System Fans

Plug the CPU fan cable to the CPU FAN connector.

If you have a chassis fan, you can also plug it into the SYSFAN connector.

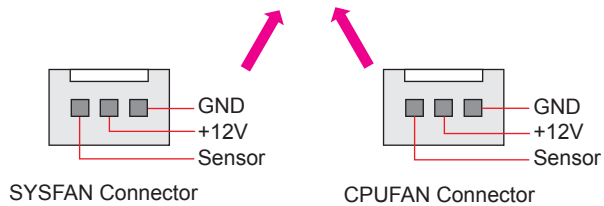

Note:



Some fans do not have a sensor pin, so fan monitoring is not supported.

2.5 Installing Memory Module

The motherboard provide SODIMM type memory support. There're two SODIMM memory slots which motherboard provided. The installation of memory module as below.

1. Put the memory module with correct direction. Notice there's one stick to make sure direction is correct.
2. Plug in memory module into SODIMM slot with angle 20~30°. Make sure memory module plug into slot completely.
3. There're tabs which located in the side of SODIMM holder. Use finger to push memory module vertically until the tabs lock memory module tightly.
4. Now, the memory modules have been plugged properly with horizontal flat.

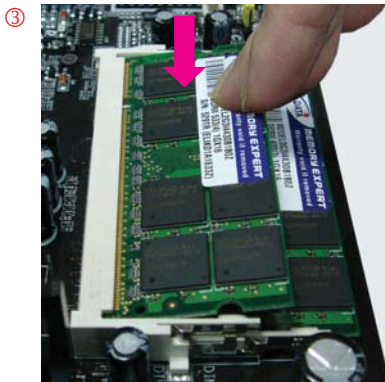
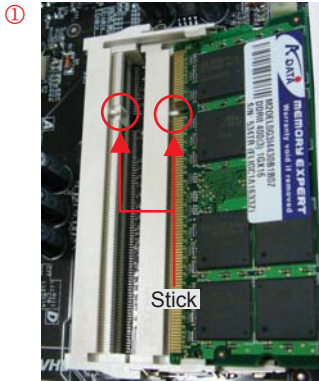

Note:

Pay careful attention to align the slot in the middle of the memory module. The tabs of the DIMM slot will clip to hold the DIMM in place when the DIMM touches the slot's bottom. You can hear it click into place.



2.6 Installing IDE Cable

The motherboard provides one IDE connector which allow you to connect two ATA 33/66/100 IDE devices like HDD.

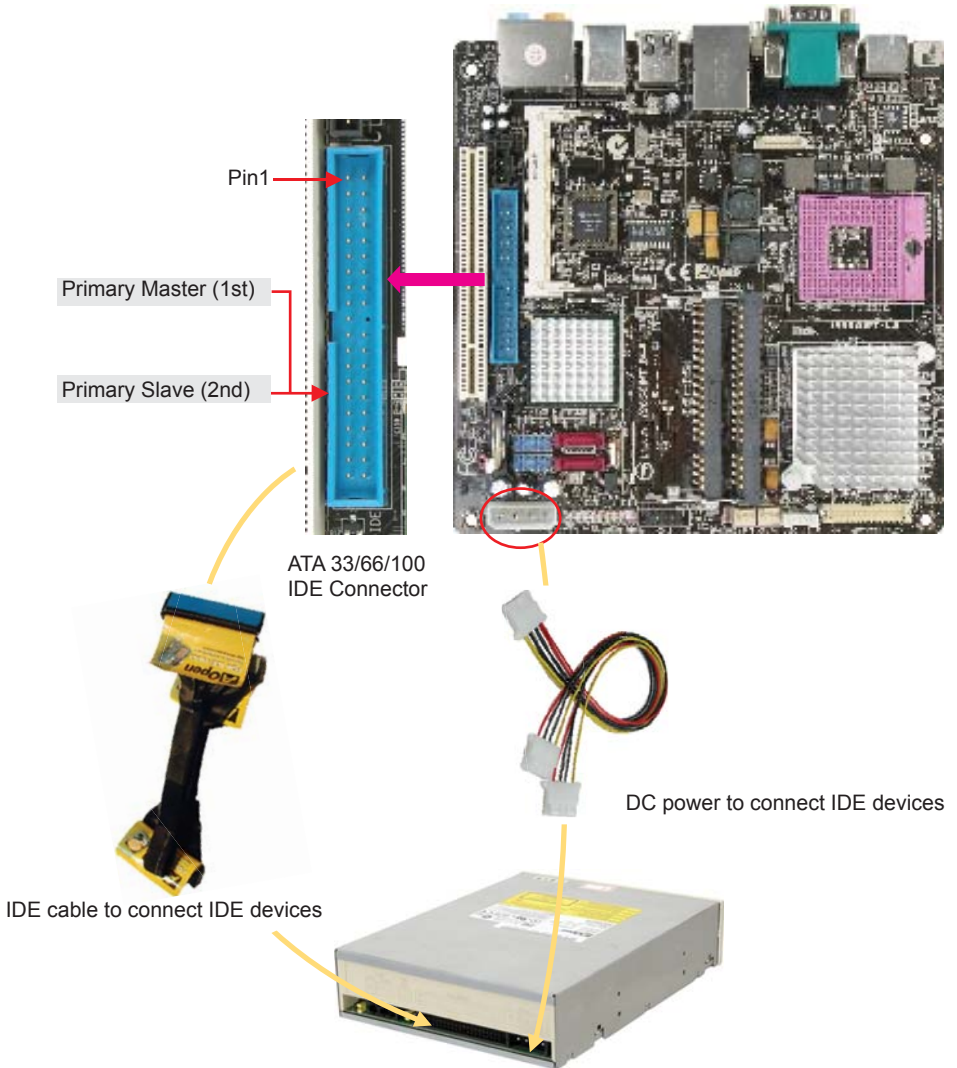

2.7 Installing SATA Cable

The mother board provides two SATA connectors.
Connect SATA cable to the on board SATA connector.
You can find SATA cable in our package. (this is SATA signal cable)
And please also connect 5V power connector with SATA power cable.

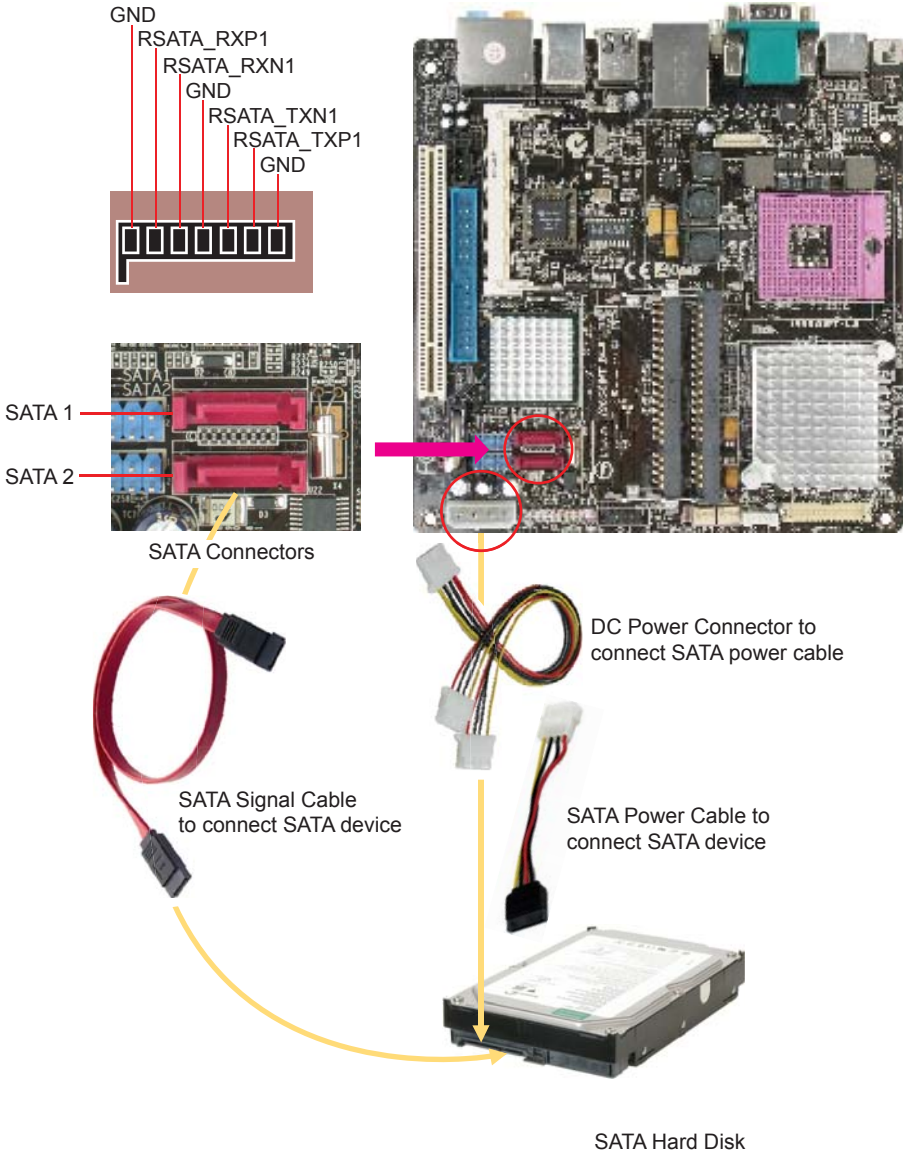

2.8 Connecting Front Panel Cable

Attach the power LED, speaker and reset switch connectors to the corresponding pins. If you enable “Suspend Mode” item in BIOS Setup, the ACPI & Power LED will keep flashing while the system is in suspend mode.

Locate the power switch cable from your housing, which is a 2-pin female connector from the housing front panel. Plug this connector to the soft-power switch connector marked SPWR.

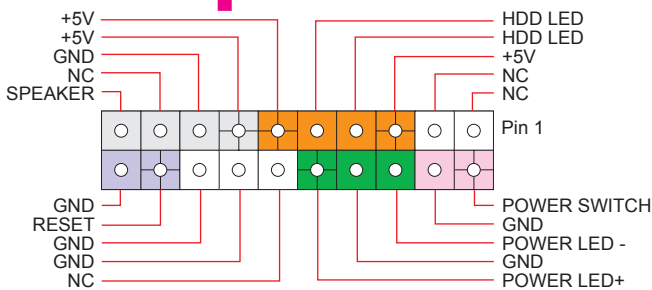

Front Panel Connector

2.9 Power Consumption

The Mother board design provides:

Parts	Voltage	Current	Power
CPU	1.3x V	43A Max.	60W Max.
Memory	1.8 V	9A Max.	16.2W Max.
North & South Bridge	1.5 V 1.05 V	6A Max. 8A Max.	9W Max. 8.4W Max.
DC 5V devices	5 V	7A Max.	35W Max.
DC 12V devices	12 V	3A Max.	36W Max.

The power consumption — 90 W provides basic system configuration as below.

- i965GMt-LA Flex ATX board
- Intel® Core 2 Duo CPU T7800 x1
- 256MB SODIMM memory Module x 2
- IDE 3.5" hard disk x 1
- USB keyboard x 1
- USB Mouse x 1
- CPU Fan + Heatsink x 1



The motherboard had bundle one 90W AC to DC power adaptor, it's specification as

- INPUT AC100-240V ~ 1.5A
- OUTPUT DC 19V ~ 4.74A

Note:



Please notice on the power, AOpen mother board provided, is 90W AC-DC adaptor. And the board can offer 145W to connect different peripherals. But it needs to be careful while connecting many peripherals and cause power over 90W. It will causes the system cannot boot-up or cannot work smoothly base on the loading your system has. If your system over 90W please change it to larger power supply: 19V AC-DC adaptor.

2.10 Mini PCI and PCI x 1 Installation

The motherboard provides one Mini PCI slot and one 1x PCI slot for users to upgrade his PC functions. Now, the Mini PCI can have digital TV tuner and Video MPEG4 decoder card ...etc. for expansion. The 1x PCI cards have SATA II and Firewire and USB cards ... etc. for expansion.



Ex.
MPEG4 encoder
Mini PCI card

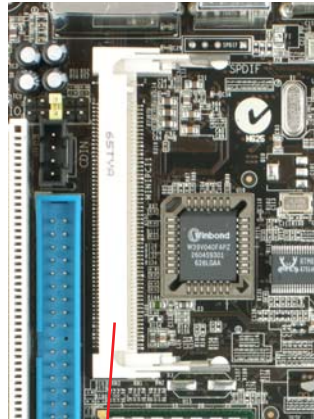

Mini PCI Slot



Ex.
PCI to SATA
PCI card

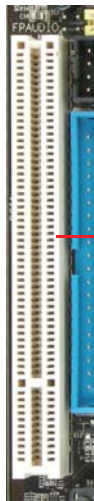

PCI Slot

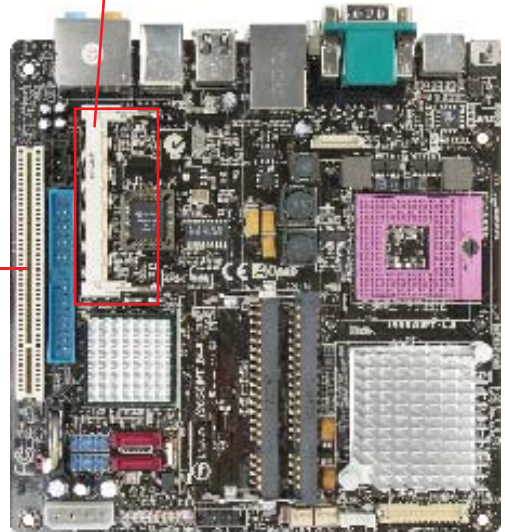

2.11 Gigabit LAN

One of the strengths is the Intel Gigabit LAN controller on board, this mother board provides 10/100/1000Mbps Ethernet for office and home use. The Ethernet RJ45 connector is located above the USB connectors. The right hand side LED indicates link mode; it lights in yellow when linking to a network. The left hand side LED indicates the transfer mode and will light in green when data is transferring at 100Mbps (never lights while at 10Mbps), and will light in orange when transferring in Gigabit mode. To enable or disable this function, you simply adjust it through the BIOS. To enable the LAN wakeup function, you have to set the “Wake on PCI Card” to enable in the BIOS “Power Management Setup” section.

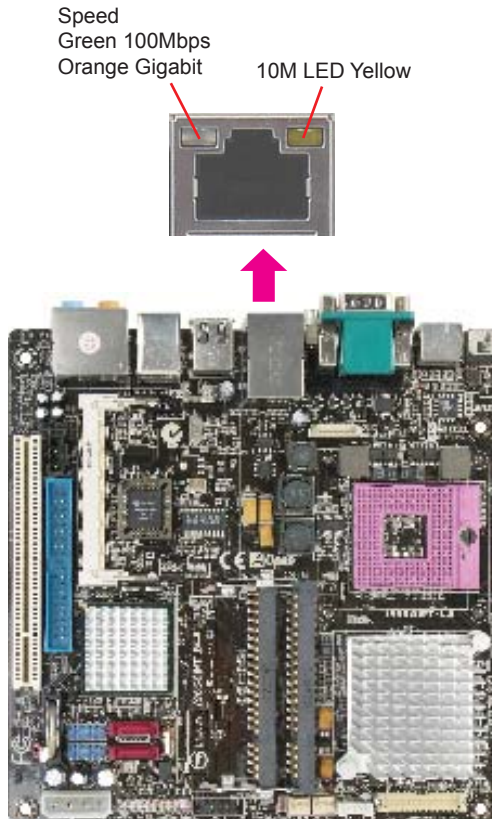

2.12 Connecting USB 2.0

This motherboard provides eight USB 2.0 ports to connect USB devices such as mouse, keyboard, modem, printer, etc. There are four ports on the back panel. You can use proper cables to connect Front USB connector to USB modules or chassis front panel.

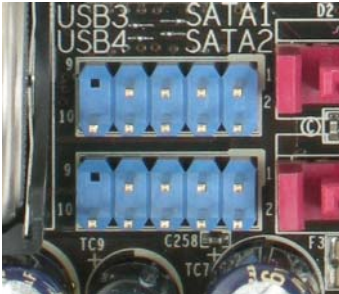
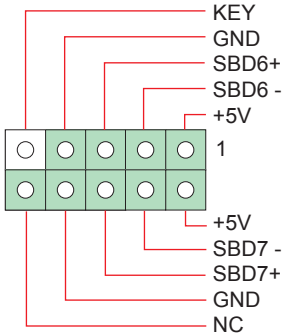

USB 2.0 Connector

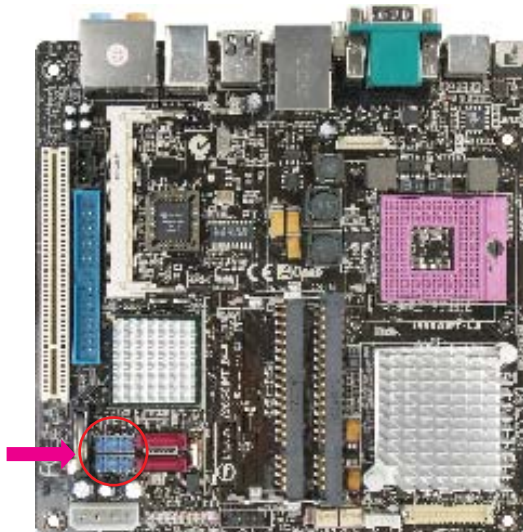

2.13 Channel Audio

This motherboard comes with an Azalia (Realtek ALC888) codec, which supports the latest 7.1 Channel sound with high quality audio effects, bringing you an excellent audio experience. This motherboard provides 7.1 Channel ports as shown below. The diagram represents the standard location of all speakers for 7.1 Channel sound use. Please connect the plug of your front speakers to the green “Speaker out” port, rear surround speakers to orange port, side surround speakers to gray port and both of the center and subwoofer speakers to the black port on the back panel.

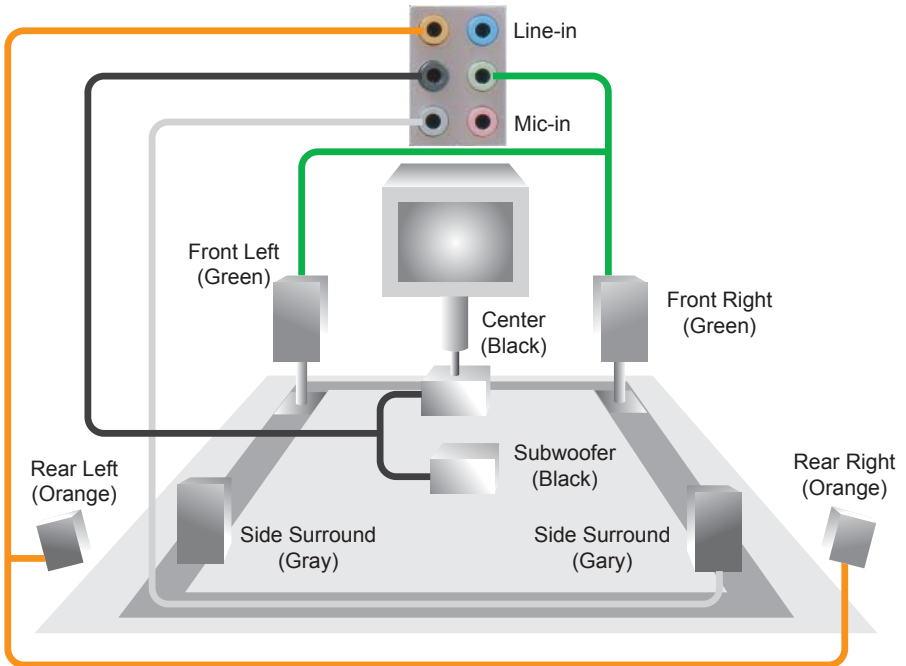

2.14 Connecting Front Audio

If the chassis is designed with an audio port on the front panel, you'll be able to connect onboard audio to the front panel through this connector. Please remove the jumper cap from the Front Audio Connector before you connect the cable. Do not remove this yellow jumper cap if your housing doesn't have an audio port on the front panel.

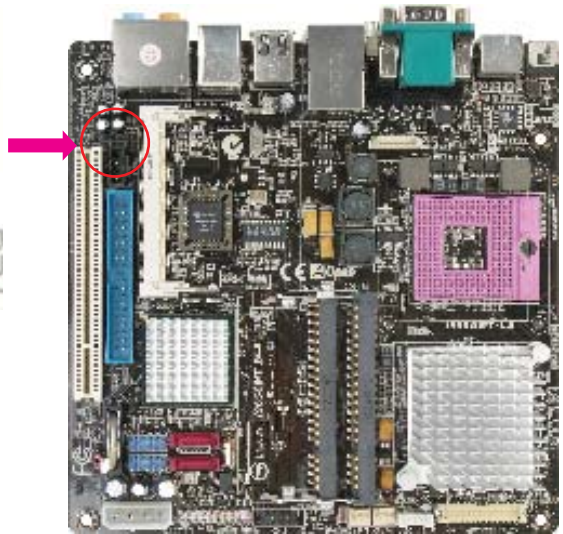
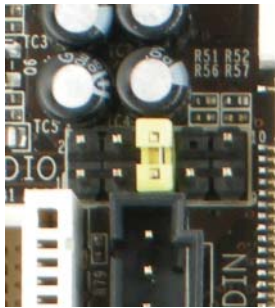

Front Audio Connector

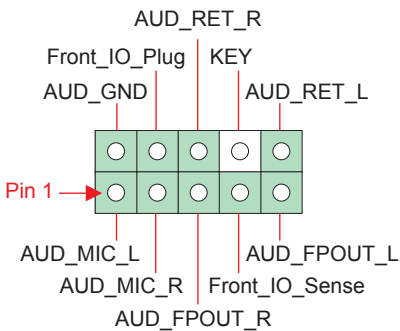

2.15 Connect CD_IN

This connector is designed to connect a CD Audio cable from CDROM or DVD drive to onboard sound.

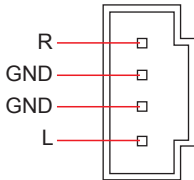
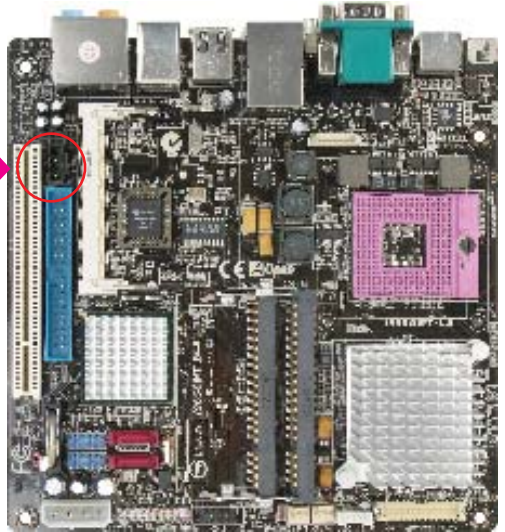
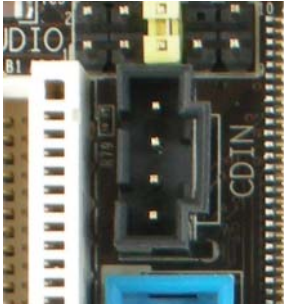

CD-IN Connector

2.16 Connect COM2 Connector

This motherboard provides two serial ports. one is on the back panel, and the other one is on the motherboard. with the proper cable, you can connect it to the back panel of chassis.

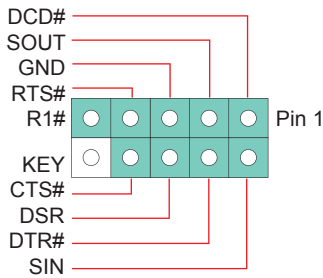

COM2 Connector



Note:



You could contact AOpen, if you don't have suitable cable.

2.17 Connecting Case Open “Chassis Intrusion”

The “CASE OPEN” header provides a chassis intrusion-monitoring function. To make this function work, you have to enable it in the system BIOS, and connect this header to a sensor somewhere on the chassis. So, whenever the sensor is triggered by lights or by the opening of the chassis, the system will beep to inform you. Please be informed that this useful function only applies to an advanced chassis; you may purchase an extra sensor, attach it on your chassis and use of this function.

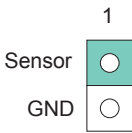

Chassis intrusion Connector

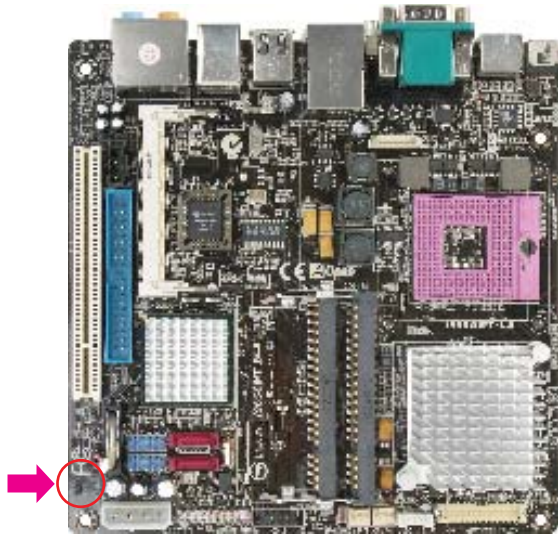

2.18 24 bits LVDS Connector (Option)

The LVDS connector supports to connect LCD modules, you could follow below LVDS pin define to connect your LCD modules.

Besidem, we provide inveter output connector to connect back light of LCD modules.

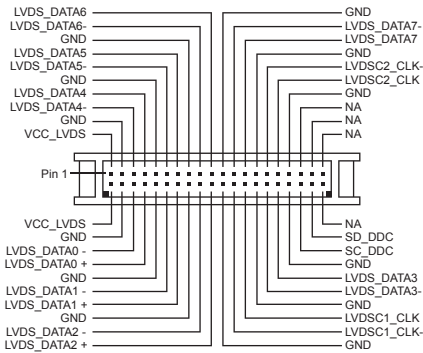
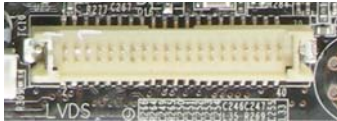

LVDS Connector (Option)

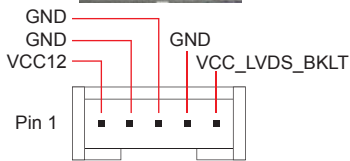
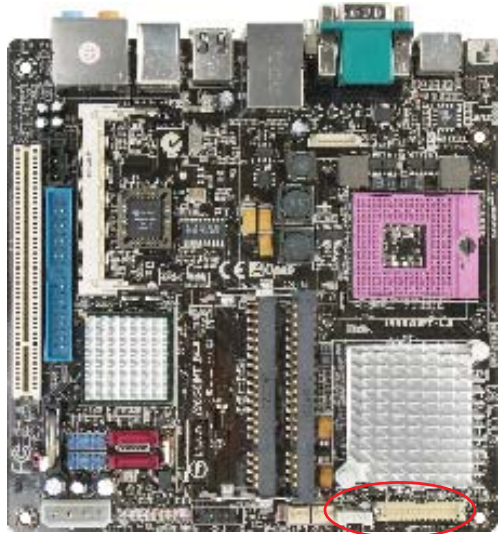

LVDS_INV Connector (Option)

PC graphic resolution table

Resolution	Color depth
2048 x 1536	256/ 16bit/ 32bit
1680 x 1050	256/ 16bit/ 32bit
1600 x 1200	256/ 16bit/ 32bit
1400 x 1050	256/ 16bit/ 32bit
1440 x 900	256/ 16bit/ 32bit
1280 x 1024	256/ 16bit/ 32bit
1280 x 720	256/ 16bit/ 32bit
1024 x 768	256/ 16bit/ 32bit
640 x 480	256/ 16bit/ 32bit

Special resolution 16:9 support

Note:

You could contact AOpen, if you don't have suitable cable.



AUO 32" 16:9 Panel: 1366 x 768
(Users need to check with your TV panels vender about it)

2.19 VGA2 Connector (Option) COM2 Port (Option)

For industrial customer, we also provide slave COM port.

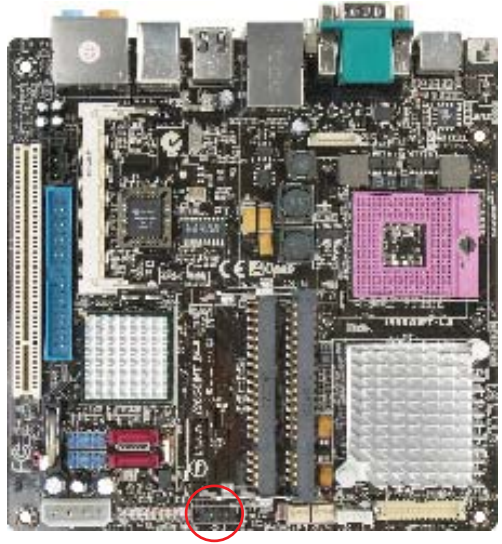
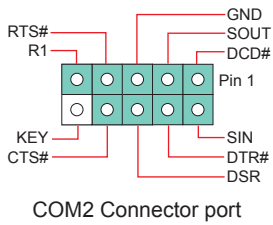

2.20 JP14 Clear CMOS Jumper

You can clear CMOS to restore system default settings. To clear the CMOS, follow the procedure below.

1. Turn off the system and unplug the AC power.
2. Locate JP14 and short pins 2-3 for a few seconds.
3. Return JP14 to its normal setting by connecting it to Pin 1-2 again.
4. Connect ATX power cable back to connector PWR3.

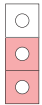

1

Normal (Default)

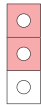

1

Clear CMOS

JP14 Clear CMOS Jumper

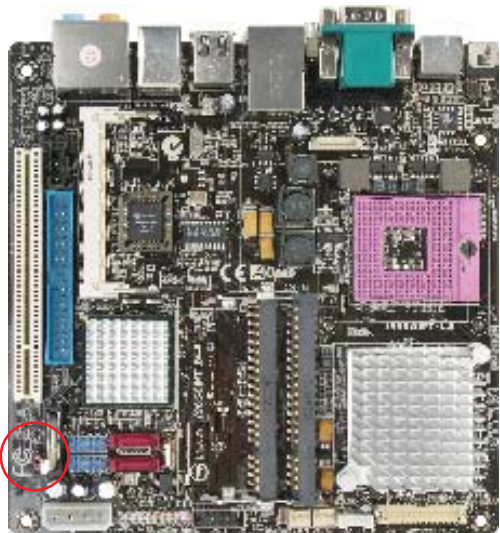
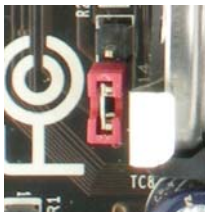

Tip:



When should I clear CMOS?

1. Boot fail
2. Forget password
3. Trouble shooting

Chapter 3 Setting the BIOS

3.1 Introduction

System parameters can be modified by going into BIOS Setup menu; this menu allows you to configure the system parameters and save the configuration into the 128 byte CMOS area (normally in the RTC chip or in the main chipset).

The Phoenix-Award BIOS™ that is installed in the Flash ROM of the motherboard is a custom version of an industry standard BIOS. The BIOS provides critical low-level support for standard devices such as hard disk drives, serial and parallel ports.

AOpen's R&D engineering team has optimized most BIOS settings of this motherboard. However, some default settings of the BIOS cannot fine-tune items that are controlled by chipset. Therefore, this chapter is intended to guide you and help you to configure some other settings. To enter the BIOS setup menu, press when POST (Power-On Self Test) screen is shown on your monitor.

Note:



Because BIOS code is the most often changed part on motherboard, the BIOS information contained in this manual may be different from the BIOS version that comes with your motherboard.

3.2 How to use the Phoenix-Award BIOS Setup Program

Generally, you can use arrow keys to highlight items that you want to choose, press <Enter> key to select, and use <Page Up> and <Page Down> keys to change setting values. You can press <Esc> key to quit Phoenix-Award™ BIOS setup program. The following table provides details about how to use the keyboard in the Phoenix-Award™ BIOS setup program.

Key	Description
Page Up or +	Change setting to next value or increase the value.
Page Down or -	Change setting to previous value or decrease value.
Enter	Select the item.
Esc In main menu	Quit without saving any changes.
Up Arrow	Highlight previous item.
Down Arrow	Highlight next item.
Left Arrow	Move the light bar to left side of menu.
Right Arrow	Move the light bar to right side of menu.
F6	Load Setup Default setting value from CMOS.
F7	Load turbo setting value from CMOS.
F10	Save changed settings and exit setup program.

3.3 How to Enter the BIOS Setup

After finishing the jumper settings and connecting cables, you can power on and enter the BIOS Setup. Press during POST (Power-On Self Test) and choose “Load Optimized Defaults” for recommended optimal performance.

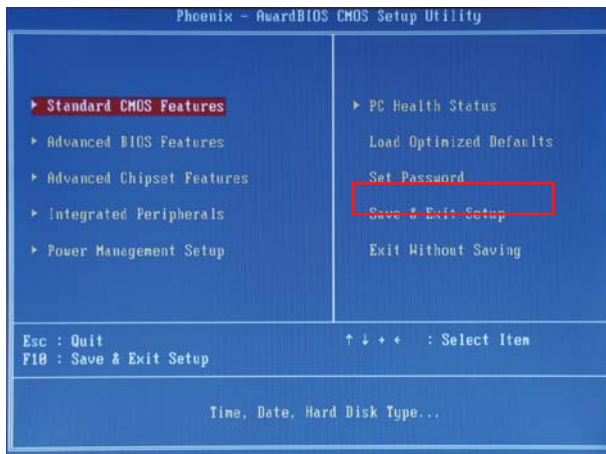

Caution:



1. Please avoid of using “Load Optimized Defaults”, unless you are certain your system components (CPU, SDRAM, HDD, etc.) have been proven acceptable for use.
2. AOpen reserves the right to change the content of this publication with out obligation to notify any party of such changes or revisions.
3. The screen above may look different from the product you purchased, BIOS screen for your reference only.

3.4 Standard CMOS Features

The “Standard CMOS Setup” sets the basic system parameters such as the date, time, and the hard disk type. Use the arrow keys to highlight an item and <PgUp> or <PgDn> to select the value for each item.



Standard CMOS Features > Date

To set the date, highlight the Date parameter. Press <PgUp> or <PgDn> to set the current date. The date format is month, date, and year.

Standard CMOS Features > Time

To set the time, highlight the Time parameter. Press <PgUp> or <PgDn> to set the current time in hour, minute, and second format. The time is based on the 24 hour military clock.

Standard CMOS features > IDE Channel 0 Master

Standard CMOS features > IDE Channel 0 Slave

Standard CMOS features > IDE Channel 1 Master

Standard CMOS features > IDE Channel 1 Slave

Standard CMOS features > IDE Channel 2 Master

Standard CMOS features > IDE Channel 2 Slave

Standard CMOS features > IDE Channel 3 Master

This item lets you select the IDE hard disk parameters that your system supports. These parameters are Size, Number of Cylinder, Number of Head, Start Cylinder for Pre-compensation, Cylinder number of Head Landing Zone and Number of Sector per Track. The default setting is Auto, which enables BIOS to automatically detect the parameters of installed HDD (Hard Disk Drive) at POST (Power-On Self Test). If you prefer to enter HDD parameters manually, select Manual.



Standard CMOS Features > IDE Channel 0 Master > IDE HDD Auto-Detection

Press “Enter” to auto-detect parameters of HDD.

Standard CMOS Features > IDE Channel 0 Master > IDE Channel 0 Master

Define the parameters of IDE devices in Channel 0 (Master or Slave).

Available options:

None: If there is no device, please select “None” for speeding boot up.

Auto: This will enable BIOS to auto-detect parameters of IDE device. (Default)

Manual: Allow users to define parameter of IDE device.

Standard CMOS Features > IDE Channel 0 Master > Access Mode

Set the using mode of HDD. Available options: **CHS / LBA / Large / Auto (default)**. User can select the mode according to the label on HDD.

Cylinder: Enter cylinder number

Head: Enter head number

Precomp: Write precompensation

Landing Zone: Location of head

Sector: Sector number

Standard CMOS Features > HaltOn

This parameter enables you to stop the system in case of Power-On Self Test (POST) error. Available items: **All errors / No errors / All, But Keyboard**

3.5 Advanced BIOS Features

This screen appears when you select the option “Advanced BIOS Features” from the main menu.



Advanced BIOS Features > CPU Feature

Can select delay time periods to enable thermal monitoring, TM2 Bus Ratio/VID, Virtualization, Disable bit

This parameter allows you to specify the system boot up search sequence.

Advanced BIOS Features > First Boot Device

Advanced BIOS Features > Second Boot Device

Advanced BIOS Features > Third Boot Device

Allows you to specify the system boot sequence.

Available options:

Removable: Floppy, USB, ZIP...etc

Hard Disk: Hard Disk Drives

CD-ROM: CD-ROM, DVD-ROM...etc

LAN: LAN Card with boot ROM

Advanced BIOS Feature > Boot Other Device

This parameter allows you to specify other boot devices not listed above.

Advanced BIOS Features > Security Option

The “System” option limits access to both the System boot and BIOS setup. A prompt asking you to enter your password appears on the screen every time you boot the system. The “Setup” option limits access only to BIOS setup. To disable the security option, select Password Setting from the main menu, don't type anything and just press <Enter>.

Advanced BIOS Features > Full Screen Logo Show

This item allows user to select to show or hide “Full Screen logos” or “Vivid BIOS logos”. Available options: Disabled, Enabled

3.6 Advanced Chipset Features

The “Advanced Chipset Features” include settings for the chipset dependent features. These features are related to system performance.



Advanced Chipset features > On-Chip Frame Buffer size

Available options: **1MB or 8MB**

Advanced Chipset features > DVMT Mode

This object is used to set DVMT mode.

Available options: **Fixed or DVMT**

Advanced Chipset features > DVMT/Fixed Memory Size

This object is used to set DVMT/Fixed memory size.

Available options: **128MB**

3.7 Integrated Peripherals

This submenu appears if you select the option “Integrated Peripherals” from the main menu. This option allows you to configure the I/O features.



Integrated Peripherals > OnChip IDE Device

Integrated Peripherals > Onboard Device

Integrated Peripherals > SuperIO Device > Power On Function

Power ON Function: This item is used to select Wake on Keyboard/Mouse mode.

Password: When disable the function of the power button, the system can only be powered on through the preset keys (like a password).

Hot Key: If selecting this option, you will need to specify the hot key from the “Hot Key Power On” item.

Mouse Left: This function allows you to wake up the system by clicking left mouse button twice.

Mouse Right: This function allows you to wake up the system by clicking right mouse button twice.

Any Key: This function allows you wake up the system by clicking any key.

Button only: Disable Wake on KB/MS function. You can boot up your system by power button only.

Keyboard 98: If this option is selected, you can boot up the system by power button and the “Wake” key on Keyboard 98.

Note:

1. Whenever you change this item, it will only take effect after you restart the system and successfully boot Windows or DOS.
2. Wake on Mouse function applies to a PS/2 mouse only.
3. If you set a password but forget it, please clear CMOS. If you want to use Wake on Mouse function in DOS, it is necessary to install the DOS driver of the mouse.

Integrated Peripherals > SuperIO Device > KB Power On Password

You can specify 1-5 keys as a password.

Integrated Peripherals > SuperIO Device > Hot Key Power On

If you selected “Hot Key” option in “Power On Function” Item, you need to specify a hot key here.

Integrated Peripherals > SuperIO Device > Onboard Serial Port 1

Available options: Disable 3F8/IRQ4 2F8/3IRQ3 3E8/IRQ4 2E8/3IRQ3 Auto

Integrated Peripherals > SuperIO Device > Onboard Serial Port 2

Available options: Disable 3F8/IRQ4 2F8/3IRQ3 3E8/IRQ4 2E8/3IRQ3 Auto

Integrated Peripherals > SuperIO Device > Power After PWR-Fail

Available options: Off On

Integrated Peripherals > USB Device Setting > USB 1.0 Controller

This item lets you enable or disable the USB 2.0 controller.

Integrated Peripherals > USB Device Setting > USB 2.0 Controller

This item lets you enable or disable the USB 2.0 controller.

3.8 Power Management Setup

The Power Management Setup screen enables you to control the motherboard green features.

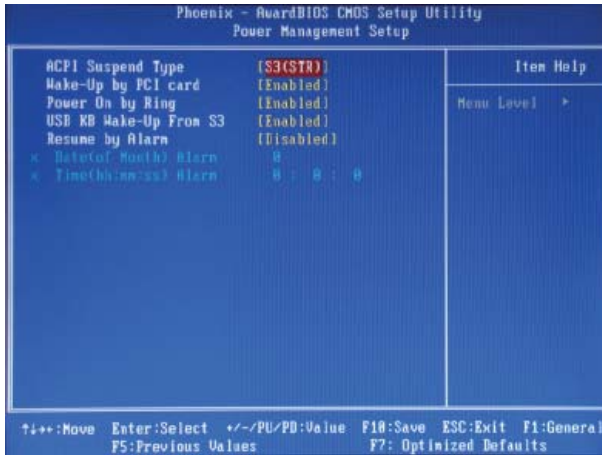

Power Management > ACPI Suspend Type

This function allows you to select suspend types. S1 is Power On Suspend and S3 is Suspend to RAM. Available Options: **S1(POS), S3(STR), S1 & S3**

Power Management > Wake-up by PCI Card

This is a function of PCI specification 2.2. PCI bus supports standby current to PCI card and PCI card can wakeup system if it detects certain activity. Available options: **Disable, Enable**

Power Management > Power On by Ring

The option lets you specify enable or disable Wake on Modem Ring function. Available Options: **Enable, Disable**

Power Management > USB KB Wake-Up From S3

The USB KB Wake-Up from S3 support USB keyboard wake up under S3 mode. Available Options: **Enable, Disable**

Power Management > Resume by Alarm

The Wake Up Timer is more like an alarm, which wakes up and powers on your system at a predefined time for a specific application. It can be set to wake up everyday or on a specific date within a month. The date/time is accurate to within a second. This option lets you enable or disable the RTC Wake Up function. Available options: By **Date**, By **Week**, **Disabled**

3.9 PC health status

The Power Management Setup screen enables you to control the motherboard green features.



Pc Health Status > System Smart Fan

Available options: Enable, Disable

Pc Health Status > CPU Smart Fan

Available options: Enable, Disable

3.10 Load Optimized Defaults

The “Load Optimized Defaults” is used to load the factory defaults for BIOS and Chipset features that are detected by the system.

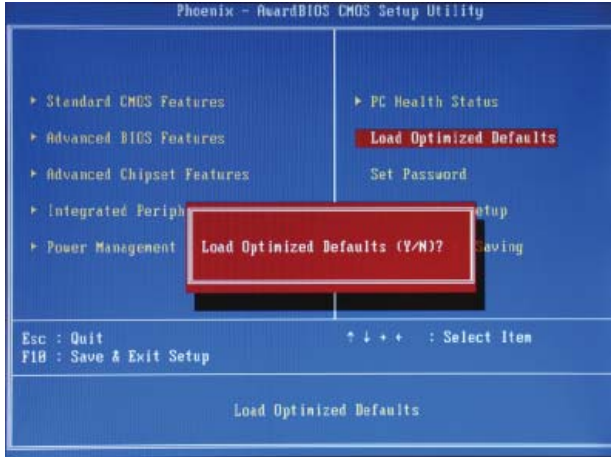

3.11 Set Password

A Password prevents unauthorized use of your computer. If you set a password, the system prompts for the correct password before boot or access to Setup.



To set a password:

1. At the prompt, type your password. Your password can be up to 8 alphanumeric characters. When you type the characters, they appear as asterisks on the password screen box.
2. After typing the password, press the “Enter” key.
3. At the next prompt, re-type your password and press the “Enter” key again to confirm the new password. After the password was typed-in, the screen automatically reverts to the main screen. To disable the password, press “Enter” when being prompted to input the password.

3.12 Save & Exit Setup

A Password prevents unauthorized use of your computer. If you set a password, the system prompts for the correct password before boot or access to Setup.

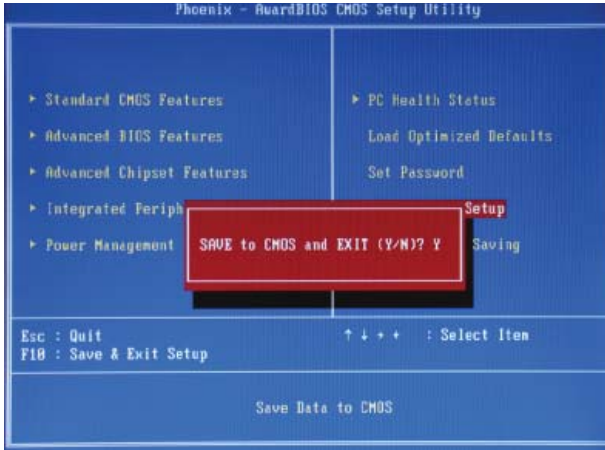

3.13 Exit Without Saving

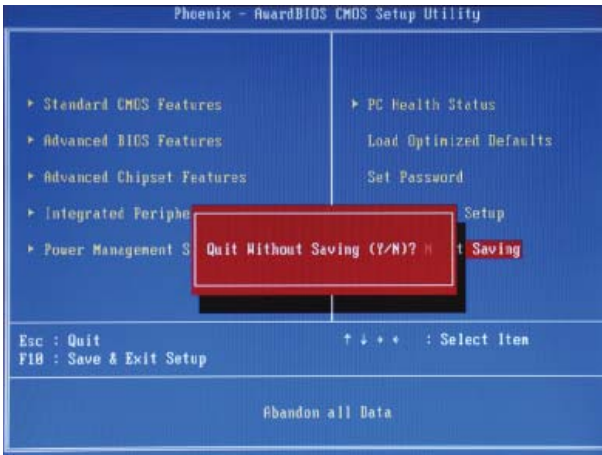

3.14 BIOS Upgrade under Windows Environment



With outstanding R&D ability of AOpen, we now bring you the EzWinFlash BIOS wizard. With an eye on convenience for users, EzWinFlash combines the BIOS binary code and flash module together, so the only thing you have to do is just click on the utility and downloaded from web and let it help you complete the flash process automatically. EzWinFlash detects your motherboard and checks the BIOS version to prevent your system from any possible failure. Moreover, EzWinFlash takes into consideration any Windows platform you might be using, no matter if you're using Windows 95/98, 98SE/ME, NT4.0/2000, or Windows XP.

In order to provide a much more user-friendly operating environment, AOpen EzWinFlash is natively designed to have multi-language function to make it easier way for users to change the BIOS setting.

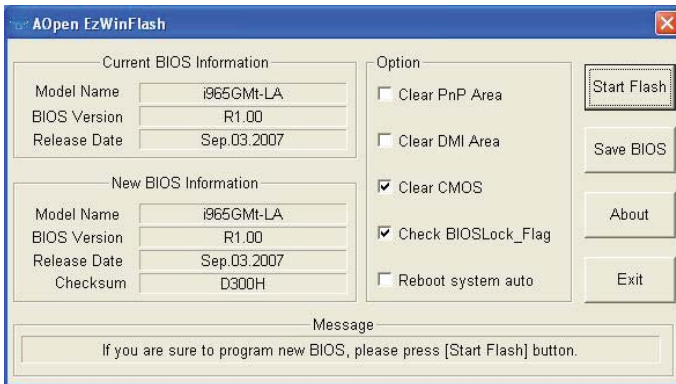

Caution: 	<p>You are taking a risk of BIOS flash failure when you update your system. If your motherboard is working stable, and there are no major bugs to be fixed by a latter BIOS revision, we recommend that you DO NOT upgrade your BIOS. If you intent on upgrade PLEASE MAKE SURE you get the right BIOS revision for your motherboard model so as to avoid any possible failure.</p>
---------------------	---

Note: 	<p>The model name on this BIOS picture is for reference only. It may not be the same model with your motherboard.</p>
------------------	---

You may accomplish BIOS upgrade procedure with EzWinFlash according to following steps, and it's **STRONGLY RECOMMENDED** to close all applications before you start the upgrades.

Download the latest version of BIOS package zip file from AOpen official web site. (Ex: <http://english.aopen.com.tw/>)

Unzip the downloaded BIOS package (ex: WSGMAXII102.ZIP) with WinZip (<http://www.winzip.com>) in Windows environment.

Save the unzipped files into a folder, for example, WSGMAXII102.EXE & WSG-MAXII102.BIN.

Double click WSGMAXII102.EXE; EzWinFlash will detect the model name and BIOS version of your motherboard. If you got the wrong BIOS, you will not be allowed to proceed with the flash steps.

You may select a preferred language in main menu, then click [Start Flash] to begin the BIOS upgrade procedure.

EzWinFlash will complete all the process automatically, and a dialogue box will pop up to ask you to restart Windows. Click [YES] to reboot Windows.



Press at POST to enter BIOS setup screen; choose “ Load Setup Defaults ”, then “ Save & Exit Setup ”. Done!

It is strongly recommended NOT to turn off the power or run any applications during FLASH PROCESS.

Warning: 	The new BIOS upgrade will permanently replace your original BIOS setting when flashing. You may need to reconfigure the BIOS setting before your system works normally again.
---	---

Chapter 4 Installing Drivers

4.1 Driver Install Utility



You may think that installing drivers and utilities would be a repeated task of going through these installation wizards and step-by-step. You will be surprised how using EzInstall makes it so easy. Without wizards or steps, all you have to do is to do is click and then it's done. Click and it is done. EzInstall makes installation easy and even foolproof!

After putting in the CD, you will be prompted with the AOpen welcome page and our branch information.

First, click on the install driver ICON on the left side for necessary drivers. Second, click on the install utility ICON on the left side for preferred utilities. You may also browse CD contents, and Readme to get more information, or just exit the CD installation.

Install Driver

Install Utility

Browse CD Contents

Read me

Exit CD



4.2 Other useful Features

Press the Icon to go to the “Install Driver” page. You may press “Back” to return to the main page.

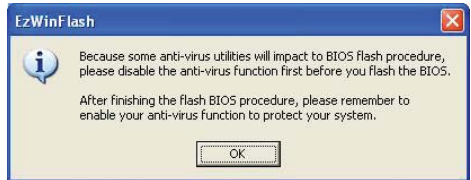

Once clicking “GO”, EzInstall will run the installing procedure automatically, and prompt a reboot dialog (Some drivers or utilities may skip the reboot part).

Note:



Due to the limitation of Intel chipsets driver, Windows 2000 is needed to be updated to service pack 4 for installing the audio driver correctly.

4.3 Useful Utilities

Installing Utilities is virtually the same as installing drivers. AOpen provides you with many friendly and powerful utilities to manage your system. You will find a lot of fabulous utilities listed here, and all you have to do is to click on “GO”, then it will install the utilities to your system right away without complicated steps.

Press the icon to go to the “Install Utilities” page for your selection. You may also press “Back” to get back to the Main page.

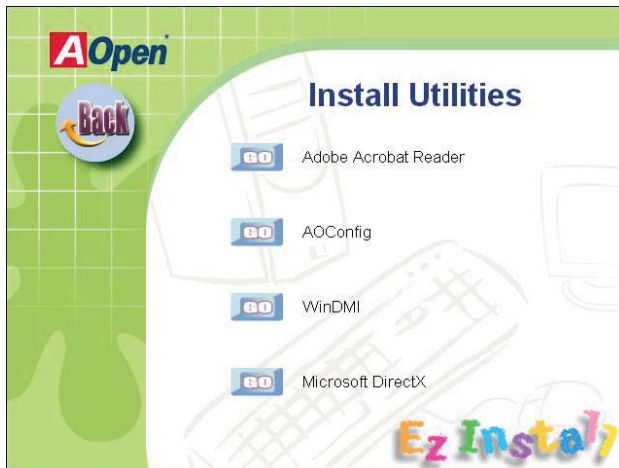

Chapter 5 Troubleshooting

5.1 Troubleshooting Steps

You are welcome to visit our technical website to learn more about these features.

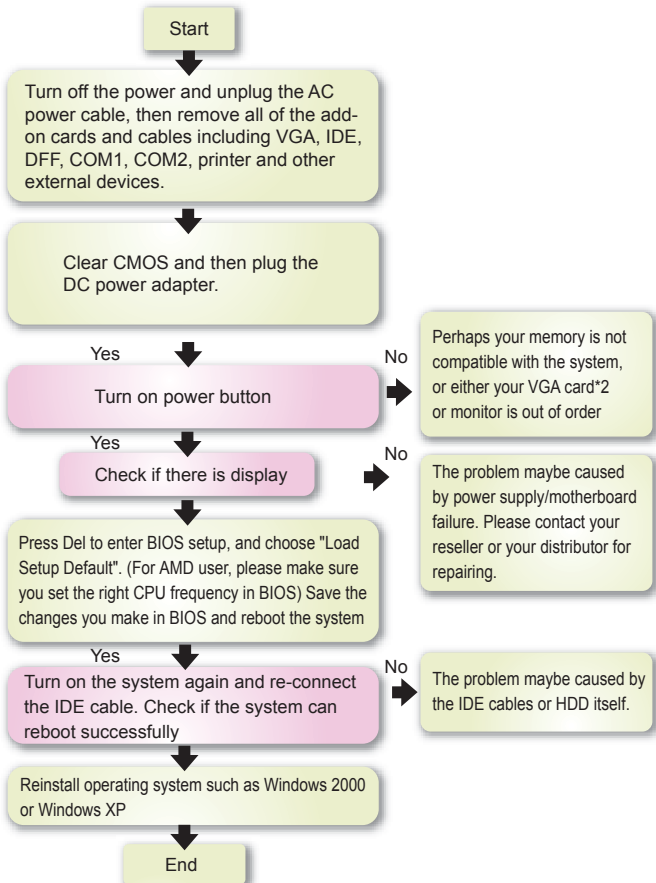

Chapter 6 Technical Support and Contact

Dear Customer,

Thanks for choosing AOpen products. We invite you to register at <http://www.aopen.com> to become a Gold Member of Club AOpen so as to ensure quality service in the future. In order to maintain the best service to every customer, we recommend you to follow the procedures below and seek help from our branches according to the region you purchased the product. With your help, we can then continue to provide efficient and high quality service to every customer.

Thank very much for your understanding!

AOpen Technical Support Team Global Locations

Europe

AOpen Computer b.v.
Email: Support@AOpen.NL

Germany

AOpen Computer GmbH.
E-mail :support@aopen.de

China

艾爾鵬國際貿易(上海)有限公司
Tel: 86-21-6225-8622
Fax: 86-21-6225-7926

Pacific Rim

AOpen Inc.
Tel: 886-2-7710-1195
Fax: 886-2-7710-1187

America

AOpen America Inc.
Tel: 1-408-586-1201
Fax: 1-408-586-1210

Japan

AOpen Japan Inc.
Fax: +81-048-288-0955



Europe Email: Support@AOpen.NL
 Pacific Rim: <http://www.aopen.com.tw>
 China: <http://www.aopen.com.cn/tech/default.htm>
 Germany: <http://www.aopencom.de/tech/default.htm>
 America: <http://usa.aopen.com>
 Japan: <http://aopen.jp/tech/index.html>

Model Name and BIOS Version

Model name and BIOS version can be found on upper left corner of first boot screen (POST screen). For example: i965GMt-LA is model name of motherboard; R1.00 is BIOS version

Register Your Motherboard

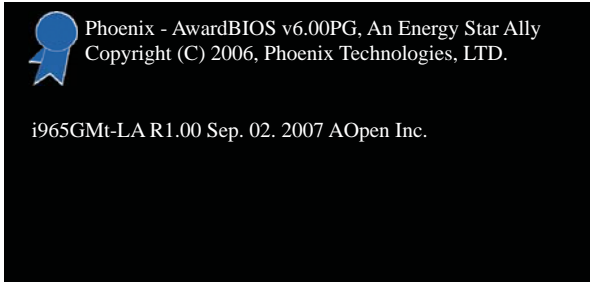

You can find this bar code label on the outside packing or on the component side of the PCB.

For example:



P/N: 9188110201 is part number, S/N: 91949378KN73 is the serial number.

Phoenix-Award BIOS ERROR Message	
Beep Sound	Message.
1 short(Beep)	System booting is normally.
1 long - 1 short(Beep)	DRAM ERROR
1 long - 2 short(Beep)	Display card or monitor connected error
1 long - 3 short(Beep)	Keyboard Error
Long(Beep) continuous	DRAM hasn't inset correctly.

AOpen Technical Support

Online Manuals: To download a manual, please log on and then select your preferred language. Under “Type” directly, choose “Manuals” to go to our manual database. You can also find the manual and EIG in AOpen Bonus Pack.

<http://www.aopen.com> > Chose Territory > Download

RCL: We recommend you to choose board/ card/device from the compatibility test reports for assembling your PC. It may prevent incompatibility problems.

<http://www.aopen.com> > Chose Territory > RCL

FAQ: Here we list problems that users often encounter and FAQ (Frequently Asked Questions). You may select your preferred language after log on, and may be able to find a solution to your problem.

<http://www.aopen.com> > Chose Territory > Tech.FAQ

Download Software: After log on and selecting language, you may get the latest updated BIOS/ utility and drivers that you need under “Type” directly. In most cases, newer versions of drivers and BIOS have solved earlier bugs, or compatibility problems.

<http://www.aopen.com> > Chose Territory > Download