

## **FCC Information and Copyright**

This equipment has been tested and found to comply with the limits of a Class B digital device, pursuant to Part 15 of the FCC Rules. These limits are designed to provide reasonable protection against harmful interference in a residential installation. This equipment generates, uses and can radiate radio frequency energy and, if not installed and used in accordance with the instructions, may cause harmful interference to radio communications. There is no guarantee that interference will not occur in a particular installation.

The vendor makes no representations or warranties with respect to the contents here and specially disclaims any implied warranties of merchantability or fitness for any purpose. Further the vendor reserves the right to revise this publication and to make changes to the contents here without obligation to notify any party beforehand.

Duplication of this publication, in part or in whole, is not allowed without first obtaining the vendor's approval in writing.

The content of this user's manual is subject to be changed without notice and we will not be responsible for any mistakes found in this user's manual. All the brand and product names are trademarks of their respective companies.

---

---

## Table of Contents

---

---

<b>Chapter 1: Introduction</b> .....	<b>1</b>
1.1 Before You Start.....	1
1.2 Package Checklist.....	1
1.3 Motherboard Features.....	2
1.4 Rear Panel Connectors (for Ver 6.x).....	4
1.5 Rear Panel Connectors (for Ver 5.x).....	4
1.6 Motherboard Layout (for Ver 6.x).....	5
1.7 Motherboard Layout (for Ver 5.x).....	6
<b>Chapter 2: Hardware Installation</b> .....	<b>7</b>
2.1 Installing Central Processing Unit (CPU).....	7
2.2 FAN Headers.....	9
2.3 Installing System Memory.....	10
2.4 Connectors and Slots.....	12
<b>Chapter 3: Headers &amp; Jumpers Setup</b> .....	<b>14</b>
3.1 How to Setup Jumpers.....	14
3.2 Detail Settings.....	14
<b>Chapter 4: Useful Help</b> .....	<b>20</b>
4.1 Driver Installation Note .....	20
4.2 Award BIOS Beep Code.....	21
4.3 Extra Information.....	21
4.4 Troubleshooting.....	23
<b>Chapter 5: WarpSpeeder™</b> .....	<b>24</b>
5.1 Introduction.....	24
5.2 System Requirement.....	24
5.3 Installation .....	25
5.4 WarpSpeeder™.....	26
<b>Appendices: SPEC In Other Language</b> .....	<b>32</b>
German.....	32
France.....	34
Italian.....	36
Spanish.....	38
Portuguese.....	40
Polish.....	42
Russian.....	44
Arabic.....	46
Japanese .....	48

## **CHAPTER 1: INTRODUCTION**

### **1.1 BEFORE YOU START**

Thank you for choosing our product. Before you start installing the motherboard, please make sure you follow the instructions below:

- Prepare a dry and stable working environment with sufficient lighting.
- Always disconnect the computer from power outlet before operation.
- Before you take the motherboard out from anti-static bag, ground yourself properly by touching any safely grounded appliance, or use grounded wrist strap to remove the static charge.
- Avoid touching the components on motherboard or the rear side of the board unless necessary. Hold the board on the edge, do not try to bend or flex the board.
- Do not leave any unfastened small parts inside the case after installation. Loose parts will cause short circuits which may damage the equipment.
- Keep the computer from dangerous area, such as heat source, humid air and water.

### **1.2 PACKAGE CHECKLIST**

- ✦ FDD Cable X 1
- ✦ HDD Cable X 1
- ✦ Rear I/O Panel for ATX Case X 1
- ✦ User's Manual X 1
- ✦ Fully Setup Driver CD X 1
- ✦ Serial ATA Cable X 1
- ✦ Serial ATA Power Cable X 1 (optional)
- ✦ USB 2.0 Cable X1 (optional)
- ✦ S/PDIF out Cable X 1 (optional)

### 1.3 MOTHERBOARD FEATURES

	<i>Ver 5.x</i>	<i>Ver 6.x</i>
CPU	LGA 775 Intel Core2Duo / Pentium 4 / Pentium D / Celeron D processor up to 3.8 GHz (*It is recommended to use processors with 95W power consumption ) Supports Hyper-Threading Execute Disable Bit Enhanced Intel SpeedStep Extended Memory 64 Technology	LGA 775 Intel Core2Duo / Pentium 4 / Pentium D / Celeron D processor up to 3.8 GHz (*It is recommended to use processors with 95W power consumption ) Supports Hyper-Threading Execute Disable Bit Enhanced Intel SpeedStep Extended Memory 64 Technology
FSB	533 / 800 MHz	533 / 800 MHz
Chipset	Intel 945GZ Intel ICH7	Intel 945GZ Intel ICH7
Graphics	Intel GMA 950 Max Shared Video Memory is 192MB	Intel GMA 950 Max Shared Video Memory is 192MB
Super I/O	ITE IT8712F H/W Monitor Fan Speed Controller ITE's "Smart Guardian" function	ITE IT8712F H/W Monitor Fan Speed Controller ITE's "Smart Guardian" function
Main Memory	DIMM Slots x 2 Each DIMM supports 256/512MB & 1GB DDR2 Max Memory Capacity 2GB Dual Channel Mode DDR2 memory module Supports DDR2 400 / 533 Registered DIMM and ECC DIMM is not supported	DIMM Slots x 2 Each DIMM supports 256/512MB & 1GB DDR2 Max Memory Capacity 2GB Dual Channel Mode DDR2 memory module Supports DDR2 400 / 533 Registered DIMM and ECC DIMM is not supported
IDE	Integrated IDE Controller Ultra DMA 33~100 Bus Master Mode supports PIO Mode 0~4,	Integrated IDE Controller Ultra DMA 33~100 Bus Master Mode supports PIO Mode 0~4,
SATA	Integrated Serial ATA Controller Data transfer rates up to 3.0 Gb/s. SATA Version 2.0 specification compliant.	Integrated Serial ATA Controller Data transfer rates up to 3.0 Gb/s. SATA Version 2.0 specification compliant.
10/100 LAN	Realtek RTL 8100C / 8110SC (optional) 10 / 100 Mb/s / 1Gb/s auto negotiation (Ggabit	Realtek RTL 8100C / 8110SC (optional) 10 / 100 Mb/s / 1Gb/s auto negotiation (Ggabit

	Ver 5.x	Ver 6.x
	bandwidth is for RTL 8110SC only) Half / Full duplex capability	bandwidth is for RTL 8110SC only) Half / Full duplex capability
Sound Codec	ALC888 7.1 channels audio out High Definition Audio	ALC861VD 5.1 channels audio out High Definition Audio
Slots	PCI Express x16 slot (x4 Speed) x1 PCI slot x3	PCI Express x16 slot (x4 Speed) x1 PCI slot x3
On Board Connector	Floppy connector x1 IDE Connector x1 Printer Port Connector x1 SATA Connector x4 Front Panel Connector x1 Front Audio Connector x1 CD-in Connector x1 SPDIF in connector (optional) x1 S/PDIF out connector (optional) x1 CPU Fan header x1 System Fan header x1 Chassis open header (optional) x1 Clear CMOS header x1 USB connector x2 Power Connector (24pin) x1 Power Connector (4pin) x1	Floppy connector x1 IDE Connector x1 Printer Port Connector x1 SATA Connector x4 Front Panel Connector x1 Front Audio Connector x1 CD-in Connector x1 SPDIF in connector (optional) x1 S/PDIF out connector (optional) x1 CPU Fan header x1 System Fan header x1 Chassis open header (optional) x1 Clear CMOS header x1 USB connector x2 Power Connector (24pin) x1 Power Connector (4pin) x1
Back Panel I/O	PS/2 Keyboard x1 PS/2 Mouse x1 Serial Port x1 VGA port x1 LAN port x1 USB Port x4 Audio Jack x6	PS/2 Keyboard x1 PS/2 Mouse x1 Serial Port x1 VGA port x1 LAN port x1 USB Port x4 Audio Jack x3
Board Size	219 (W) x 235 (L) mm	219 (W) x 235 (L) mm
OS Support	Windows 2000 / XP / VISTA Biostar Reserves the right to add or remove support for any OS with or without notice.	Windows 2000 / XP / VISTA Biostar Reserves the right to add or remove support for any OS with or without notice.

### 1.4 REAR PANEL CONNECTORS (FOR VER 6.X)

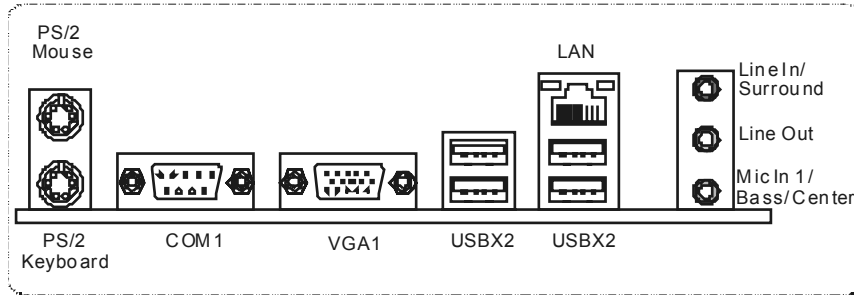

### 1.5 REAR PANEL CONNECTORS (FOR VER 5.X)

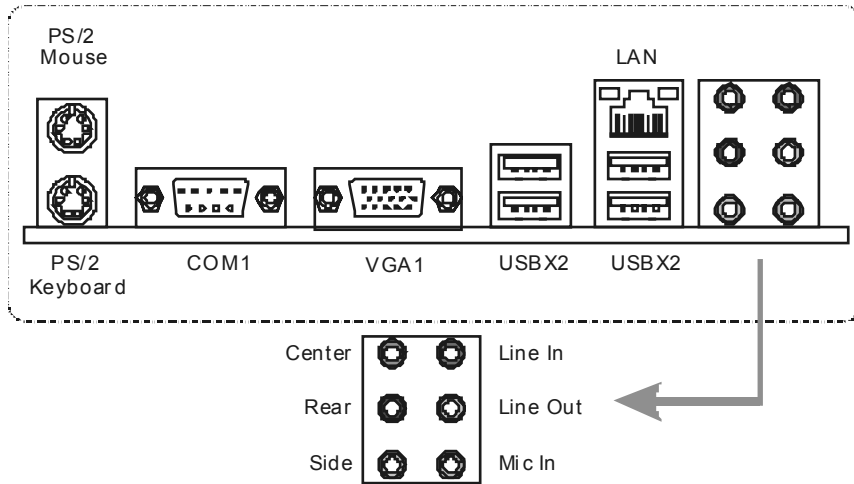

Since the audio chip supports High Definition Audio Specification, the function of each audio jack can be defined by software. The input / output function of each audio jack listed above represents the default setting. However, when connecting external microphone to the audio port, please use the Line In (blue) and Mic In (Pink) audio jack.

## 1.6 MOTHERBOARD LAYOUT (FOR VER 6.X)

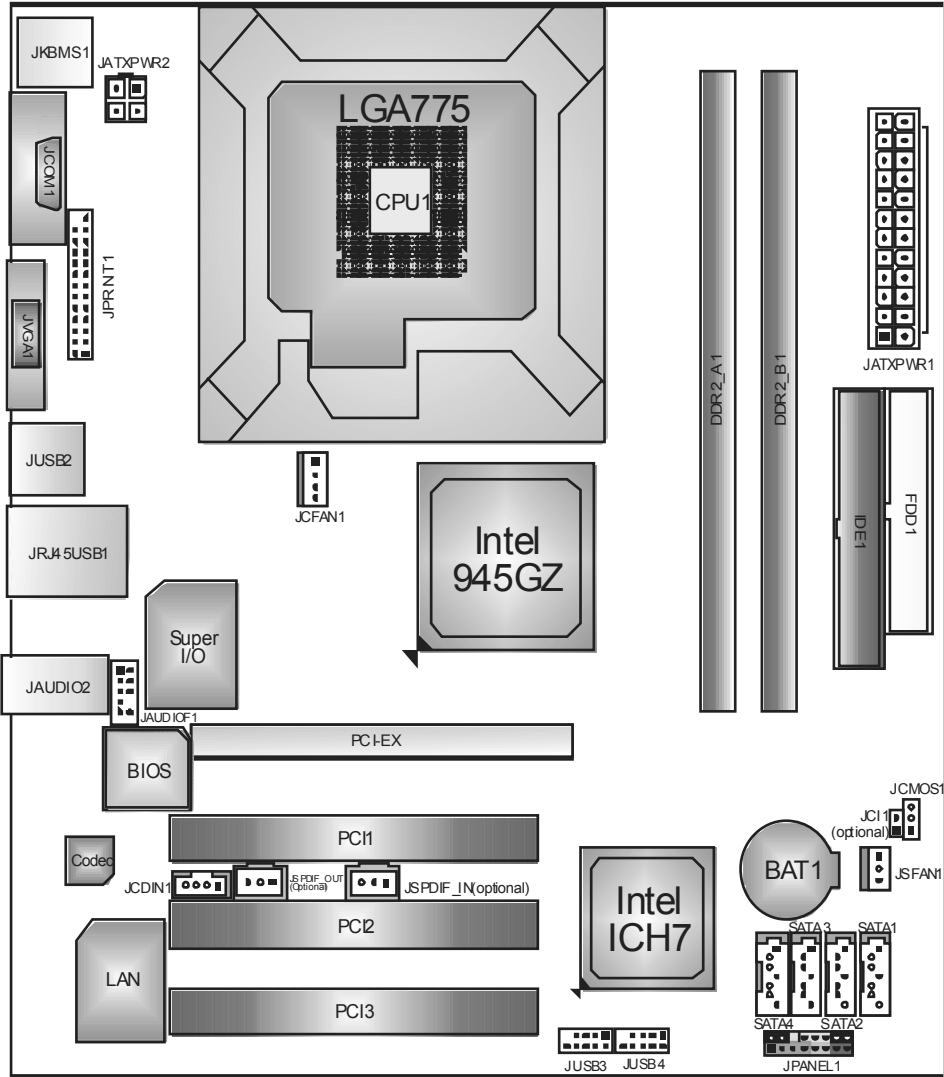

**Note:** ■ represents the 1<sup>st</sup> pin.

## 1.7 MOTHERBOARD LAYOUT (FOR VER 5.x)

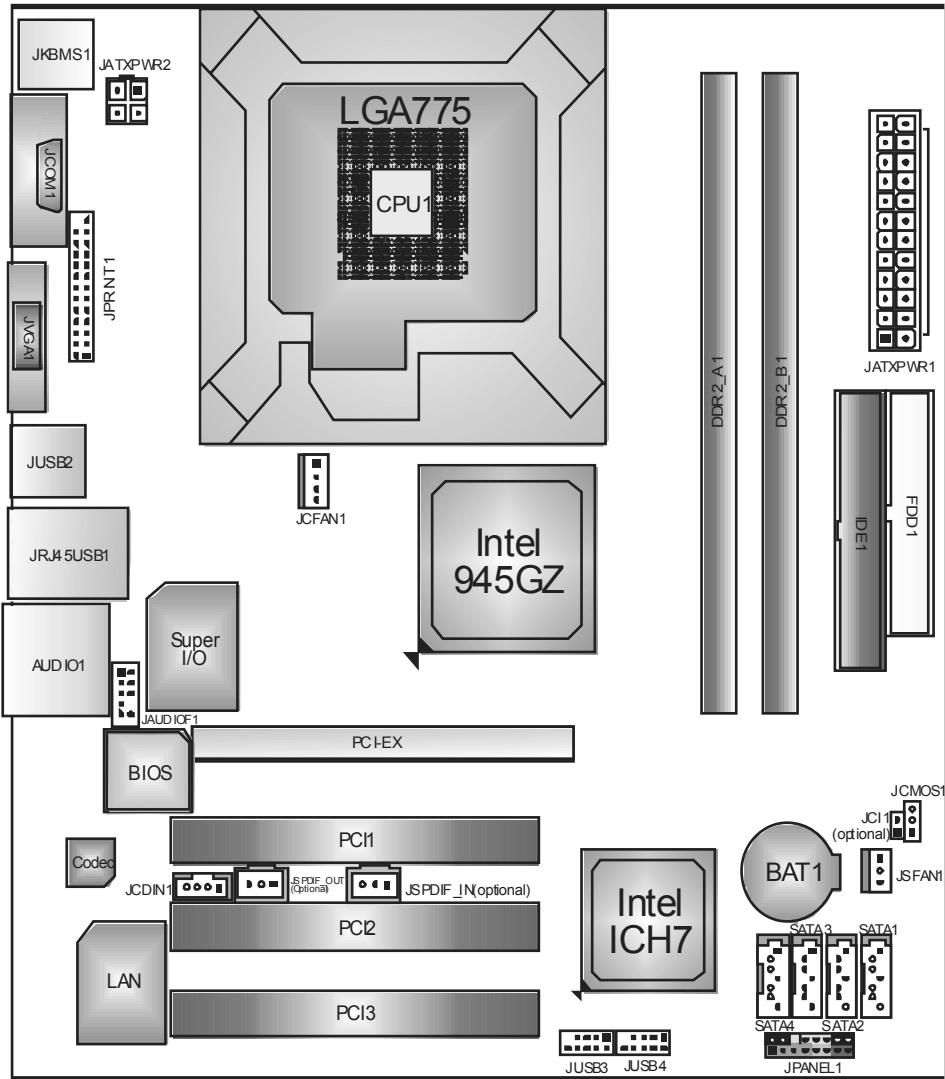

**Note:** ■ represents the 1<sup>st</sup> pin.



## CHAPTER 2: HARDWARE INSTALLATION

### 2.1 INSTALLING CENTRAL PROCESSING UNIT (CPU)

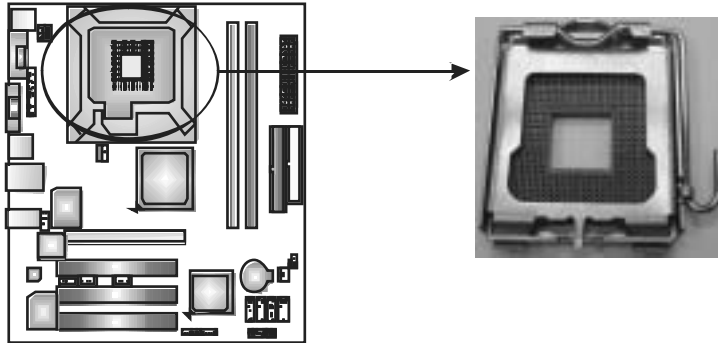

***Special Notice***

**Remove Pin Cap before installation, and make good preservation for future use. When the CPU is removed, cover the Pin Cap on the empty socket to ensure pin legs won't be damaged.**



**Pin-Cap**

**Step 1:** Pull the socket locking lever out from the socket and then raise the lever up to a 90-degree angle.

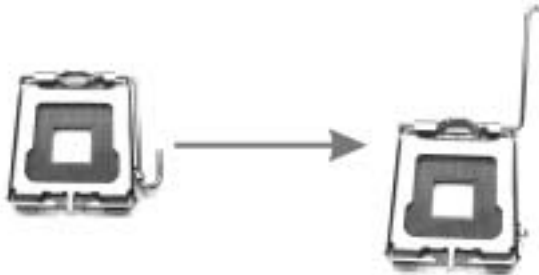

**Step 2:** Look for the triangular cut edge on socket, and the golden dot on CPU should point forwards this triangular cut edge. The CPU will fit only in the correct orientation.

*Step 2-1:*



*Step 2-2:*

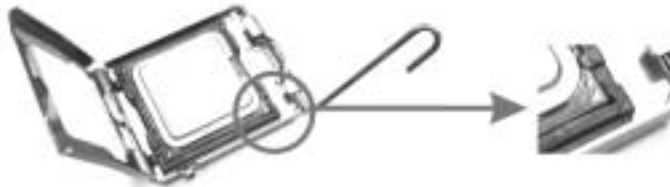

**Step 3:** Hold the CPU down firmly, and then lower the lever to locked position to complete the installation.



**Step 4:** Put the CPU Fan and heatsink assembly on the CPU and buckle it on the retention frame. Connect the CPU FAN power cable into the JCFAN1. This completes the installation.

## 2.2 FAN HEADERS

These fan headers support cooling-fans built in the computer. The fan cable and connector may be different according to the fan manufacturer. Connect the fan cable to the connector while matching the black wire to pin#1.

### JCFAN1: CPU Fan Header

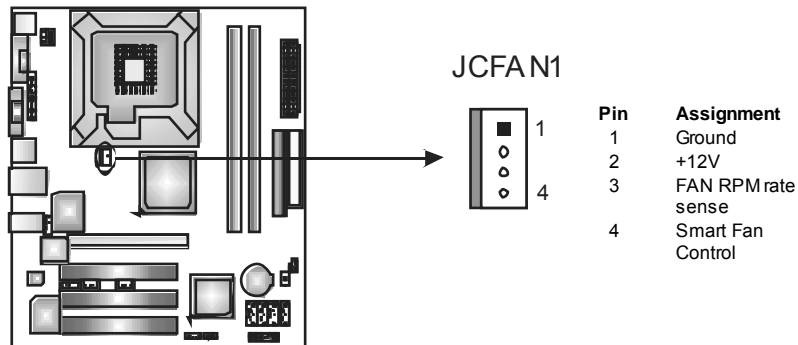

### JSFAN1: System Fan Header

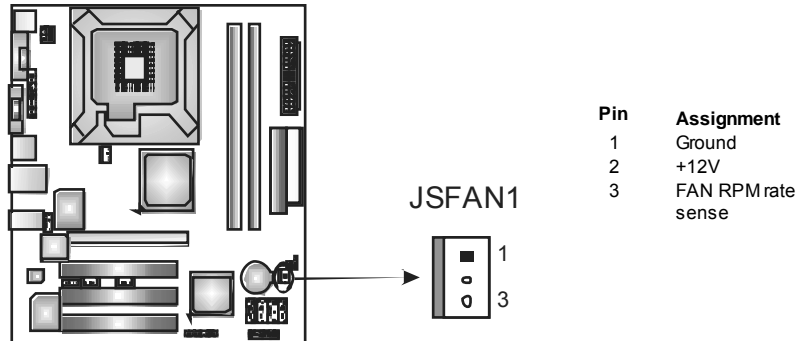

**Note:**

The JCFAN1 and JSFAN1 support 4-pin and 3-pin head connector. When connecting with wires onto connectors, please note that the red wire is the positive and should be connected to pin#2, and the black wire is Ground and should be connected to GND.

## 2.3 INSTALLING SYSTEM MEMORY

### A. DDR2 module

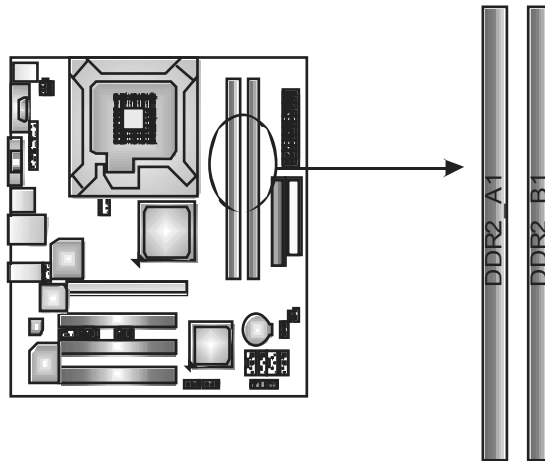

1. Unlock a DIMM slot by pressing the retaining dips outward. Align a DIMM on the slot such that the notch on the DIMM matches the break on the Slot.

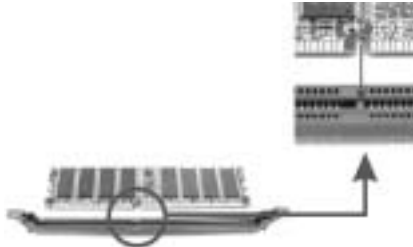

2. Insert the DIMM vertically and firmly into the slot until the retaining chip snap back in place and the DIMM is properly seated.



### B. Memory Capacity

DIMM Socket Location	DDR2 Module	Total Memory Size
DDR2_A1	256MB/512MB/1GB *1	Max memory 2GB.
DDR2_B1	256MB/512MB/1GB *1	

### C. Dual Channel Memory installation

To trigger the Dual Channel function of the motherboard, the memory module must meet the following requirements:

Install memory module of the same density in pairs, shown in the following table.

Dual Channel Status	DDR2_A1	DDR2_B1
Disabled	O	X
Disabled	X	O
Enabled	O	O

(O means memory installed, X means memory not installed.)

The DRAM bus width of the memory module must be the same (x8 or x16)

## 2.4 CONNECTORS AND SLOTS

### FDD1: Floppy Disk Connector

The motherboard provides a standard floppy disk connector that supports 360K, 720K, 1.2M, 1.44M and 2.88M floppy disk types. This connector supports the provided floppy drive ribbon cables.

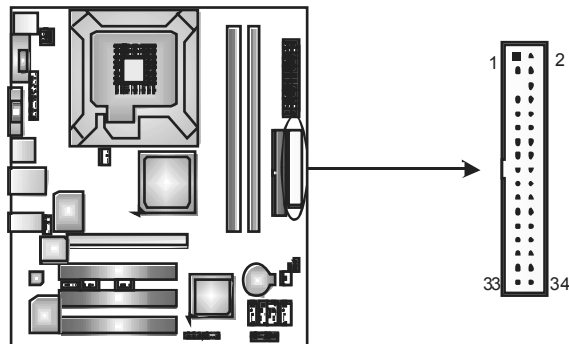

### IDE1: Hard Disk Connector

The motherboard has a 32-bit Enhanced PCI IDE Controller that provides PIO Mode 0~4, Bus Master, and Ultra DMA 33/66/100 functionality.

The IDE connector can connect a master and a slave drive, so you can connect up to two hard disk drives.

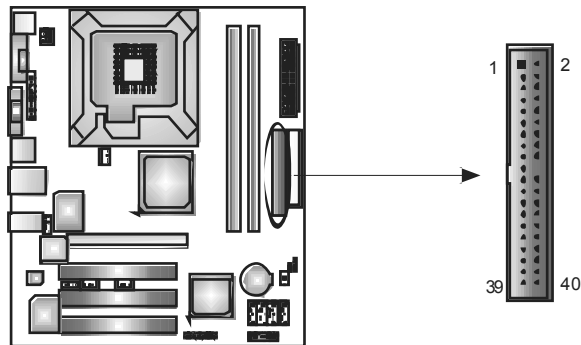

**PCI-EX: PCI-Express x16 Slot (x4 Speed)**

- PCI-Express 1.0a compliant.
- Maximum theoretical realized bandwidth of 1GB/s simultaneously per direction, for an aggregate of 2GB/s totally.

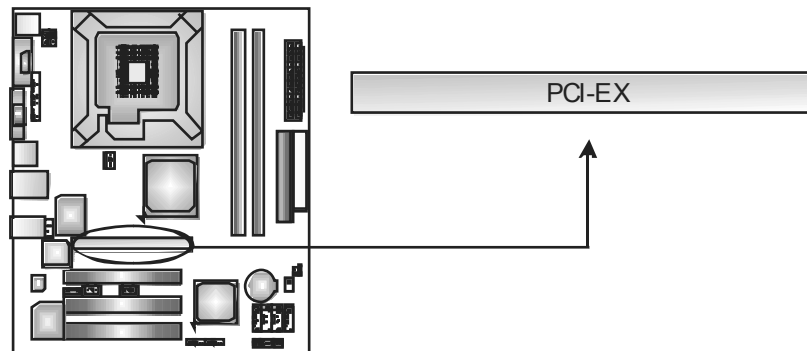

**PCI1~PCI3: Peripheral Component Interconnect Slots**

The motherboard is equipped with 3 PCI standard PCI Slots. PCI stands for Peripheral Component Interconnect, and it is a bus standard for expansion cards. This PCI slot is designated as 32 bits.

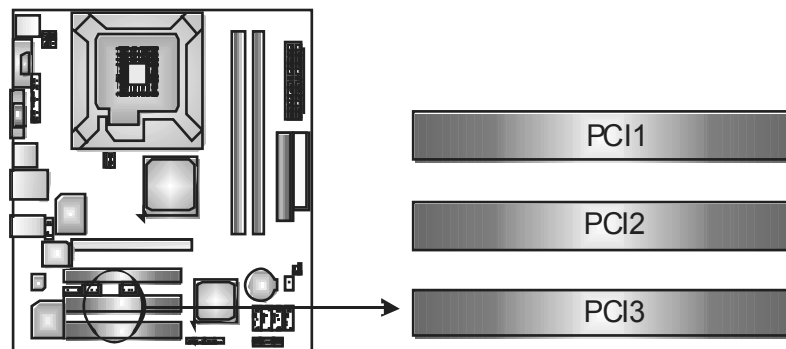

## CHAPTER 3: HEADERS & JUMPERS SETUP

### 3.1 HOW TO SETUP JUMPERS

The illustration shows how to set up jumpers. When the jumper cap is placed on pins, the jumper is “close”, if not, that means the jumper is “open”.



Pin opened



Pin closed



Pin1-2 closed

### 3.2 DETAIL SETTINGS

#### JPANEL1: Front Panel Header

This 16-pin connector includes Power-on, Reset, HDD LED, Power LED, Sleep button, and speaker. It allows user to connect the PC case's front panel switch functions.

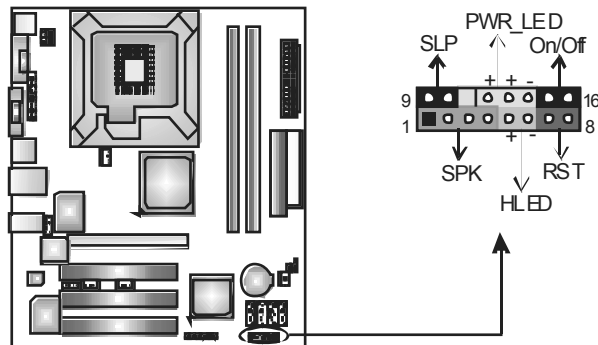

Pin	Assignment	Function	Pin	Assignment	Function
1	+5V	Speaker Connector	9	Sleep control	Sleep button
2	N/A		10	Ground	N/A
3	N/A		11	N/A	
4	Speaker	Hard drive LED	12	Power LED (+)	Power LED
5	HDD LED (+)		13	Power LED (+)	
6	HDD LED (-)	Reset button	14	Power LED (-)	
7	Ground		15	Power button	Power-on button
8	Reset control	16	Ground		



**JATXPWR1: ATX Power Source Connector**

This connector allows user to connect 24-pin power connector on the ATX power supply.

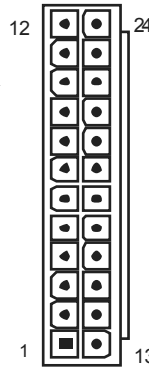
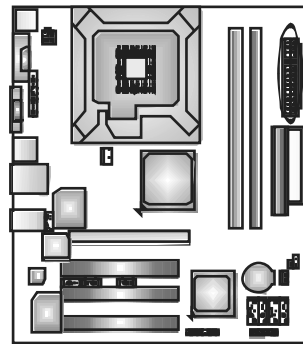

Pin	Assignment
1	+3.3V
2	+3.3V
3	Ground
4	+5V
5	Ground
6	+5V
7	Ground
8	PW_OK
9	Standby Voltage +5V
10	+12V
11	+12V
12	2 x 12 Detect
13	+3.3V
14	-12V
15	Ground
16	PS_ON
17	Ground
18	Ground
19	Ground
20	-5V
21	+5V
22	+5V
23	+5V
24	Ground

**JATXPWR2: ATX Power Source Connector**

By connecting this connector, it will provide +12V to CPU power circuit.

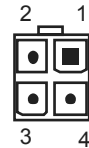
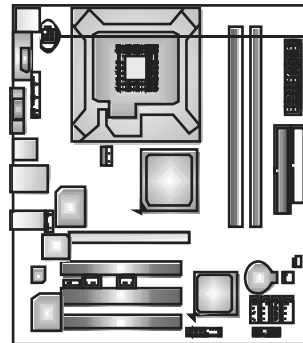

Pin	Assignment
1	+12V
2	+12V
3	Ground
4	Ground

### JUSB3/JUSB4: Headers for USB 2.0 Ports at Front Panel

This motherboard provides 2 USB 2.0 headers, which allows user to connect additional USB cable on the PC front panel, and also can be connected with internal USB devices, like USB card reader.

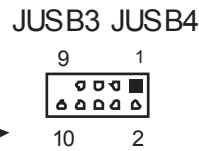
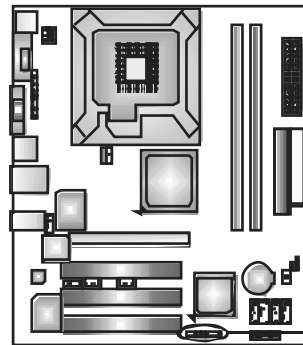

Pin	Assignment
1	+5V (fused)
2	+5V (fused)
3	USB-
4	USB-
5	USB+
6	USB+
7	Ground
8	Ground
9	Key
10	NC

### JAUDIOF1: Front Panel Audio Header

This header allows user to connect the front audio output cable with the PC front panel. It will disable the output on back panel audio connectors.

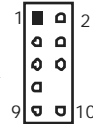
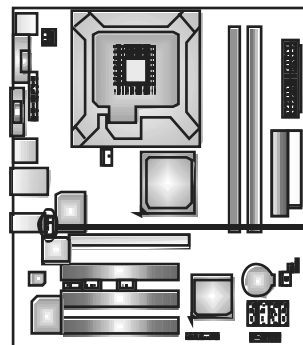

Pin	Assignment
1	Mic Left in
2	Ground
3	Mic Right in
4	GPIO
5	Right line in
6	Jack Sense
7	Front Sense
8	Key
9	Left line in
10	Jack Sense

**JCDIN1: CD-ROM Audio-in Connector**

This connector allows user to connect the audio source from the variety devices, like CD-ROM, DVD-ROM, PCI sound card, PCI TV turner card etc..

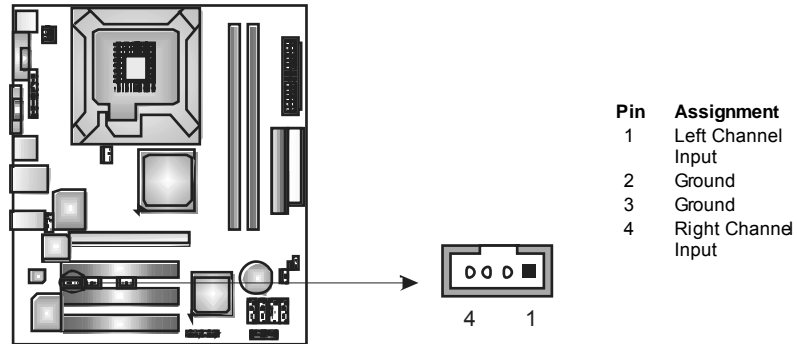
**JCMOS1: Clear CMOS Header**

By placing the jumper on pin2-3, it allows user to restore the BIOS safe setting and the CMOS data, please carefully follow the procedures to avoid damaging the motherboard.

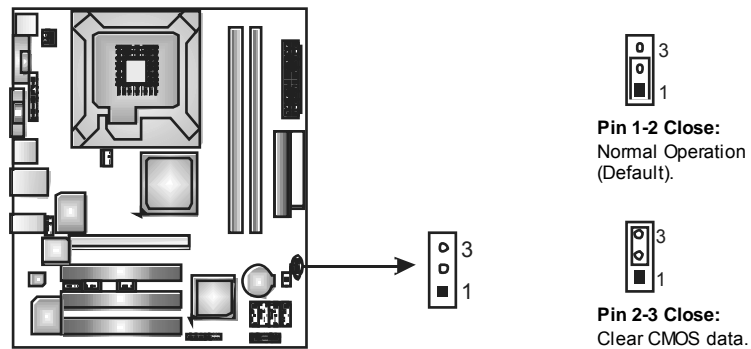
**※ Clear CMOS Procedures:**

1. Remove AC power line.
2. Set the jumper to "Pin 2-3 close".
3. Wait for five seconds.
4. Set the jumper to "Pin 1-2 close".
5. Power on the AC.
6. Reset your desired password or clear the CMOS data.

**JCI1: Chassis Open Header (Optional)**

This connector allows system to monitor PC case open status. If the signal has been triggered, it will record to the CMOS and show the message on next boot-up.

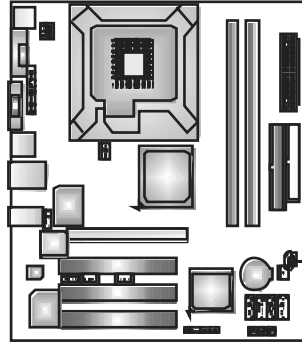

Pin	Assignment
1	Case open signal
2	Ground



**SATA1~SATA4: Serial ATA Connectors**

The motherboard has a PCI to SATA Controller with 4channels SATA interface, it satisfies the SATA 2.0 spec and with transfer rate of 3Gb/s.

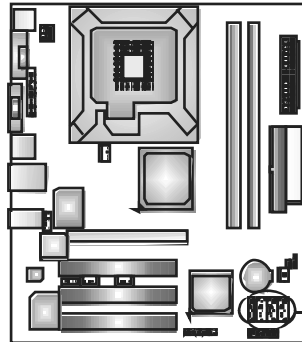

SATA4 SATA2  
SATA3 SATA1

Pin	Assignment
1	Ground
2	TX+
3	TX-
4	Ground
5	RX-
6	RX+
7	Ground

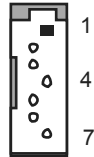

**JSPDIF\_OUT: Digital Audio out Connector (Optional)**

This connector allows user to connect the PCI bracket SPDIF output header.

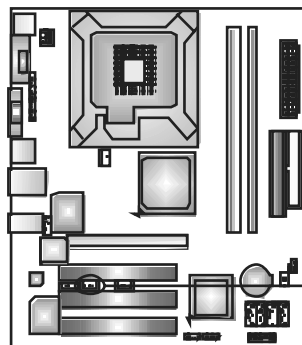

Pin	Assignment
1	+5V
2	SPDIF_OUT
3	Ground

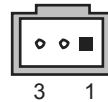

**JSPDIF\_IN: Digital Audio in Connector (Optional)**

This connector allows user to connect the PCI bracket SPDIF input header.

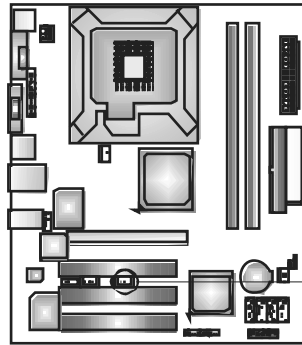

Pin	Assignment
1	+5V
2	SPDIF_IN
3	Ground

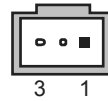

**JPRNT1: Printer Port Connector**

This header allows you to connector printer on the PC.

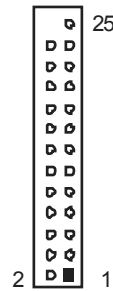
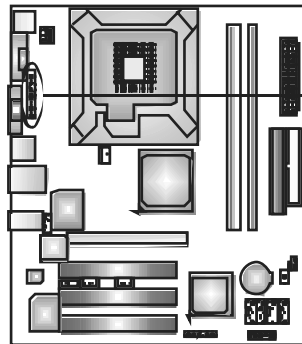

Pin	Assignment	Pin	Assignment
1	-Strobe	14	Ground
2	-ALF	15	Data 6
3	Data 0	16	Ground
4	-Error	17	Data 7
5	Data 1	18	Ground
6	-Init	19	-ACK
7	Data 2	20	Ground
8	-Scltin	21	Busy
9	Data 3	22	Ground
10	Ground	23	PE
11	Data 4	24	Ground
12	Ground	25	SCLT
13	Data 5	26	Key

## CHAPTER 4: USEFUL HELP

### 4.1 DRIVER INSTALLATION NOTE

After you installed your operating system, please insert the Fully Setup Driver CD into your optical drive and install the driver for better system performance.

You will see the following window after you insert the CD

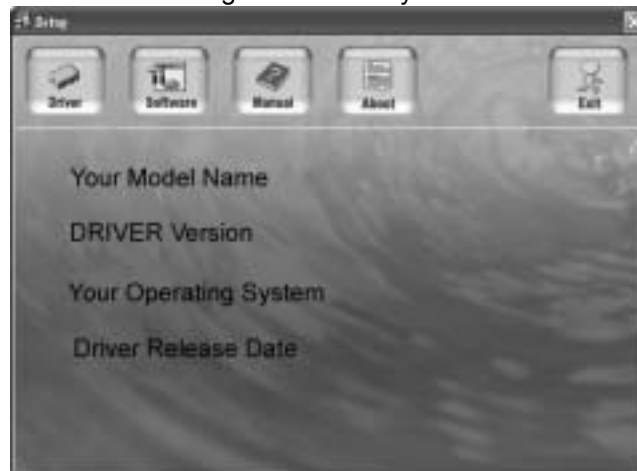

The setup guide will auto detect your motherboard and operating system.

**Note:**

If this window didn't show up after you insert the Driver CD, please use file browser to locate and execute the file **SETUP.EXE** under your optical drive.

#### **A. Driver Installation**

To install the driver, please click on the Driver icon. The setup guide will list the compatible driver for your motherboard and operating system. Click on each device driver to launch the installation program.

#### **B. Software Installation**

To install the software, please click on the Software icon. The setup guide will list the software available for your system, click on each software title to launch the installation program.

#### **C. Manual**

Aside from the paperback manual, we also provide manual in the Driver CD. Click on the Manual icon to browse for available manual.

**Note:**

You will need Acrobat Reader to open the manual file. Please download the latest version of Acrobat Reader software from <http://www.adobe.com/products/acrobat/readstep2.html>

## 4.2 AWARD BIOS BEEP CODE

Beep Sound	Meaning
One long beep followed by two short beeps	Video card not found or video card memory bad
High-low siren sound	CPU overheated System will shut down automatically
One Short beep when system boot-up	No error found during POST
Long beeps every other second	No DRAM detected or install

## 4.3 EXTRA INFORMATION

### A. BIOS Update

After you fail to update BIOS or BIOS is invaded by virus, the Boot-Block function will help to restore BIOS. If the following message is shown after boot-up the system, it means the BIOS contents are corrupted.

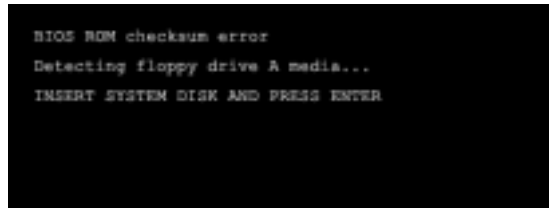

In this Case, please follow the procedure below to restore the BIOS:

1. Make a bootable floppy disk.
2. Download the Flash Utility "AWDFLASH.exe" from the Biostar website: [www.biostar.com.tw](http://www.biostar.com.tw)
3. Confirm motherboard model and download the respectively BIOS from Biostar website.
4. Copy "AWDFLASH.exe" and respectively BIOS into floppy disk.
5. Insert the bootable disk into floppy drive and press Enter.
6. System will boot-up to DOS prompt.
7. Type "*Awdflash xxxx.bf/sn/py/r*" in DOS prompt.  
(xxxx means BIOS name.)
8. System will update BIOS automatically and restart.
9. The BIOS has been recovered and will work properly.

### **B. CPU Overheated**

If the system shutdown automatically after power on system for seconds, that means the CPU protection function has been activated.

When the CPU is over heated, the motherboard will shutdown automatically to avoid a damage of the CPU, and the system may not power on again.

In this case, please double check:

1. The CPU cooler surface is placed evenly with the CPU surface.
2. CPU fan is rotated normally.
3. CPU fan speed is fulfilling with the CPU speed.

After confirmed, please follow steps below to relief the CPU protection function.

1. Remove the power cord from power supply for seconds.
2. Wait for seconds.
3. Plug in the power cord and boot up the system.

Or you can:

1. Clear the CMOS data.  
(See "Close CMOS Header: JCMOS1" section)
2. Wait for seconds.
3. Power on the system again.



## 4.4 TROUBLESHOOTING

Probable	Solution
1. No power to the system at all Power light don't illuminate, fan inside power supply does not turn on. 2. Indicator light on key board does not turn on.	1. Make sure power cable is securely plugged in. 2. Replace cable. 3. Contact technical support.
System inoperative. Keyboard lights are on, power indicator lights are lit, and hard drive is spinning.	Using even pressure on both ends of the DIMM, press down firmly until the module snaps into place.
System does not boot from hard disk drive, can be booted from optical drive.	1. Check cable running from disk to disk controller board. Make sure both ends are securely plugged in; check the drive type in the standard CMOS setup. 2. Backing up the hard drive is extremely important. All hard disks are capable of breaking down at any time.
System only boots from optical drive. Hard disk can be read and applications can be used but booting from hard disk is impossible.	1. Back up data and applications files. 2. Reformat the hard drive. Re-install applications and data using backup disks.
Screen message says "Invalid Configuration" or "CMOS Failure."	Review system's equipment. Make sure correct information is in setup.
Cannot boot system after installing second hard drive.	1. Set master/slave jumpers correctly. 2. Run SETUP program and select correct drive types. Call the drive manufacturers for compatibility with other drives.

## **CHAPTER 5: WARPSPEEDER™**



### **5.1 INTRODUCTION**

[WarpSpeeder™], a new powerful control utility, features three user-friendly functions including Overclock Manager, Overvoltage Manager, and Hardware Monitor.

With the Overclock Manager, users can easily adjust the frequency they prefer or they can get the best CPU performance with just one click. The Overvoltage Manager, on the other hand, helps to power up CPU core voltage and Memory voltage. The cool Hardware Monitor smartly indicates the temperatures, voltage and CPU fan speed as well as the chipset information. Also, in the About panel, you can get detail descriptions about BIOS model and chipsets. In addition, the frequency status of CPU, memory, AGP and PCI along with the CPU speed are synchronically shown on our main panel.

Moreover, to protect users' computer systems if the setting is not appropriate when testing and results in system fail or hang, [WarpSpeeder™] technology assures the system stability by automatically rebooting the computer and then restart to a speed that is either the original system speed or a suitable one.

### **5.2 SYSTEM REQUIREMENT**

OS Support: Windows 98 SE, Windows Me, Windows 2000, Windows XP  
DirectX: DirectX 8.1 or above. (The Windows XP operating system includes DirectX 8.1. If you use Windows XP, you do not need to install DirectX 8.1.)

## 5.3 INSTALLATION

1. Execute the setup execution file, and then the following dialog will pop up. Please click "Next" button and follow the default procedure to install.

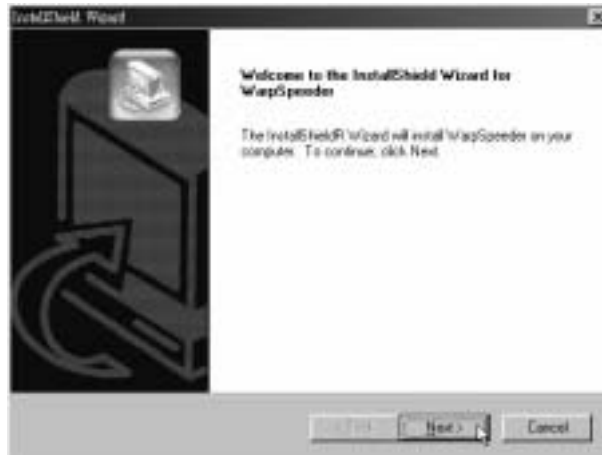

2. When you see the following dialog in setup procedure, it means setup is completed. If the "Launch the WarpSpeeder Tray Utility" checkbox is checked, the Tray Icon utility and [WarpSpeeder™] utility will be automatically and immediately launched after you click "Finish" button.



### Usage:

The following figures are just only for reference, the screen printed in this user manual will change according to your motherboard on hand.

## 5.4 WARPSPEDER™

### 1. **Tray Icon:**

Whenever the Tray Icon utility is launched, it will display a little tray icon on the right side of Windows Taskbar.

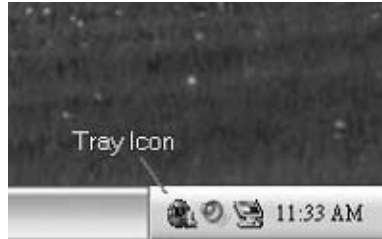

This utility is responsible for conveniently invoking [WarpSpeeder™] Utility. You can use the mouse by clicking the left button in order to invoke [WarpSpeeder™] directly from the little tray icon or you can right-click the little tray icon to pop up a popup menu as following figure. The “Launch Utility” item in the popup menu has the same function as mouse left-click on tray icon and “Exit” item will close Tray Icon utility if selected.



## 2. Main Panel

If you click the tray icon, [WarpSpeeder™] utility will be invoked. Please refer to the following figure; the utility's first window you will see is Main Panel.

### Main Panel contains features as follows:

- Display the CPU Speed, CPU external dock, Memory dock, AGP dock, and PCI dock information.
- Contains About, Voltage, Overclock, and Hardware Monitor Buttons for invoking respective panels.
- With a user-friendly Status Animation, it can represent 3 overclock percentage stages:

Man walking → overclock percentage from 100% ~ 110 %

Panther running → overclock percentage from 110% ~ 120%

Car racing → overclock percentage from 120% ~ above

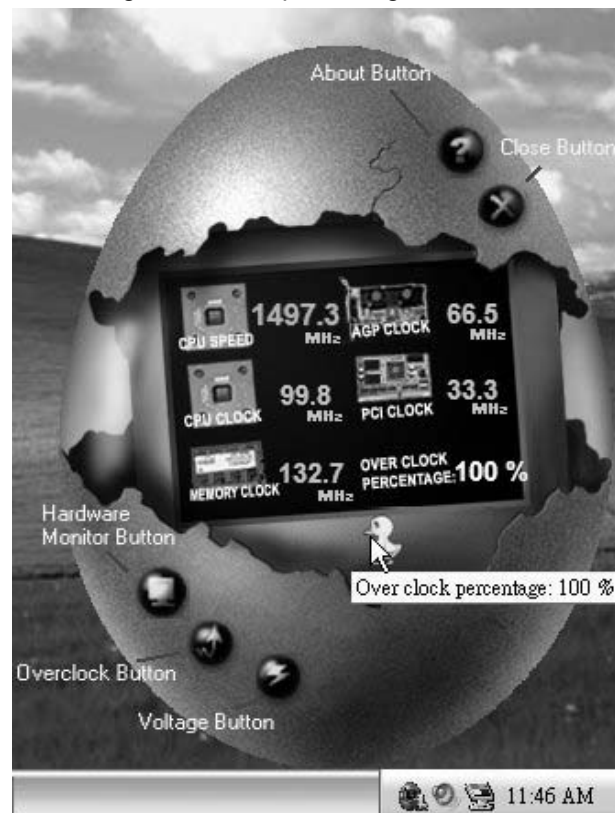

### 3. Voltage Panel

Click the Voltage button in Main Panel, the button will be highlighted and the Voltage Panel will slide out to up as the following figure.

In this panel, you can decide to increase CPU core voltage and Memory voltage or not. The default setting is "No". If you want to get the best performance of overlocking, we recommend you click the option "Yes".



#### 4. Overclock Panel

Click the Overclock button in Main Panel, the button will be highlighted and the Overclock Panel will slide out to left as the following figure.

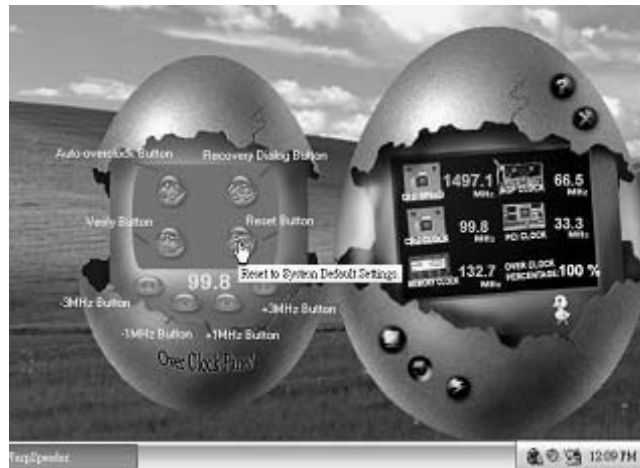

**Overclock Panel contains the these features:**

- “-3MHz button”, “-1MHz button”, “+1MHz button”, and “+3MHz button”:  
provide user the ability to do real-time overclock adjustment.

**Warning:**

Manually overclock is potentially dangerous, especially when the overlocking percentage is over 110 %. We strongly recommend you verify every speed you overclock by click the Verify button. Or, you can just click Auto overclock button and let [WarpSpeeder™] automatically gets the best result for you.

- “Recovery Dialog button”: Pop up the following dialog. Let user select a restoring way if system need to do a fail-safe reboot.



- c. “Auto-overclock button”: User can click this button and [WarpSpeeder™] will set the best and stable performance and frequency automatically. [WarpSpeeder™] utility will execute a series of testing until system fail. Then system will do fail-safe reboot by using Watchdog function. After reboot, the [WarpSpeeder™] utility will restore to the hardware default setting or load the verified best and stable frequency according to the Recovery Dialog's setting.
- d. “Verify button”: User can click this button and [WarpSpeeder™] will proceed a testing for current frequency. If the testing is ok, then the current frequency will be saved into system registry. If the testing fail, system will do a fail-safe rebooting. After reboot, the [WarpSpeeder™] utility will restore to the hardware default setting or load the verified best and stable frequency according to the Recovery Dialog's setting.

**Note:**

Because the testing programs, invoked in Auto-overclock and Verify, include DirectDraw, Direct3D and DirectShow tests, the DirectX 8.1 or newer runtime library is required. And please make sure our display card's color depth is High color (16 bit) or True color ( 24/32 bit ) that is required for Direct3D rendering.

**5. Hardware Monitor Panel**

Click the Hardware Monitor button in Main Panel, the button will be highlighted and the Hardware Monitor panel will slide out to left as the following figure.

In this panel, you can get the real-time status information of your system. The information will be refreshed every 1 second.





## 6. About Panel

Click the “about” button in Main Panel, the button will be highlighted and the About Panel will slide out to up as the following figure.

In this panel, you can get model name and detail information in hints of all the chipset that are related to overclocking. You can also get the mainboard’s BIOS model and the Version number of [WarpSpeeder™] utility.

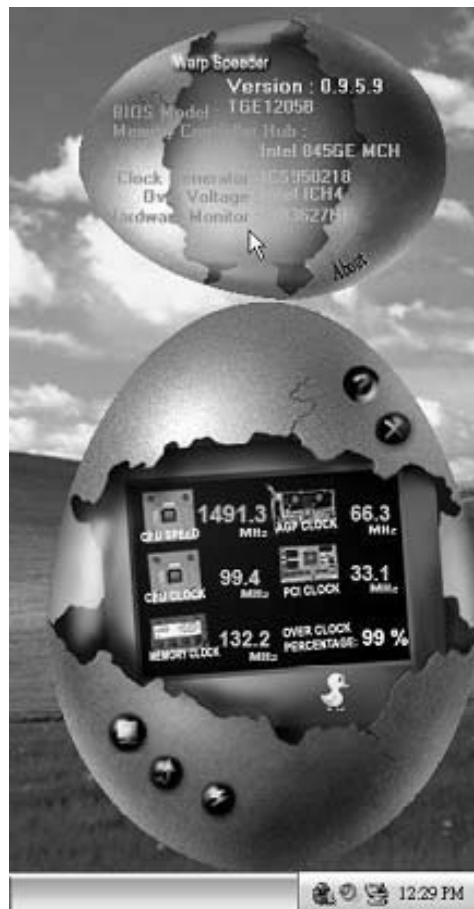

### Note:

Because the overclock, overvoltage, and hardware monitor features are controlled by several separate chipset, [WarpSpeeder™] divide these features to separate panels. If one chipset is not on board, the correlative button in Main panel will be disabled, but will not interfere other panels’ functions. This property can make [WarpSpeeder™] utility more robust.

**APPENDENCIES: SPEC IN OTHER LANGUAGE****GERMAN**

	<i>Ver 5.x</i>	<i>Ver 6.x</i>
CPU	LGA 775 Intel Core2Duo / Pentium 4 / Pentium D / Celeron D Prozessoren mit bis zu 3,8 GHz (*It is recommended to use processors with 95W power consumption ) Unterstützt Hyper-Threading Execute Disable Bit Enhanced Intel SpeedStep® Extended Memory 64 Technology	LGA 775 Intel Core2Duo / Pentium 4 / Pentium D / Celeron D Prozessoren mit bis zu 3,8 GHz (*It is recommended to use processors with 95W power consumption ) Unterstützt Hyper-Threading Execute Disable Bit Enhanced Intel SpeedStep® Extended Memory 64 Technology
FSB	533 / 800 MHz	533 / 800 MHz
Chipsatz	Intel 945GZ Intel ICH7	Intel 945GZ Intel ICH7
Grafik	Intel GMA 950 Max. 192MB gemeinsam benutzter Videospeicher	Intel GMA 950 Max. 192MB gemeinsam benutzter Videospeicher
Super E/A	ITE 8712F Hardware-Überwachung Lüfterdrehzahl-Controller "Smart Guardian"-Funktion von ITE	ITE 8712F Hardware-Überwachung Lüfterdrehzahl-Controller "Smart Guardian"-Funktion von ITE
Arbeitsspeicher	DDR2 DIMM-Steckplätze x 2 Jeder DIMM unterstützt 256/512MB & 1GB DDR Max. 2GB Arbeitsspeicher Dual-Kanal DDR2 Speichermodul Unterstützt DDR2 400 / 533 DIMMs. ECC DIMMs werden nicht unterstützt.	DDR2 DIMM-Steckplätze x 2 Jeder DIMM unterstützt 256/512MB & 1GB DDR Max. 2GB Arbeitsspeicher Dual-Kanal DDR2 Speichermodul Unterstützt DDR2 400 / 533 DIMMs. ECC DIMMs werden nicht unterstützt.
IDE	Integrierter IDE-Controller Ultra DMA 33 / 66 / 100 Bus Master-Modus Unterstützt PIO-Modus 0~4	Integrierter IDE-Controller Ultra DMA 33 / 66 / 100 Bus Master-Modus Unterstützt PIO-Modus 0~4
SATA	Integrierter Serial ATA-Controller Datenübertragungsraten bis zu 3Gb/s Konform mit der SATA-Spezifikation Version 2.0	Integrierter Serial ATA-Controller Datenübertragungsraten bis zu 3Gb/s Konform mit der SATA-Spezifikation Version 2.0
LAN	Realtek RTL 8100C / RTL 8110SC (optional) 10 / 100 / 1000 Mb/s Auto-Negotiation (Gigabit-Bandbreite nur beim RTL 8110SC) Halb-/Voll duplex-Funktion	Realtek RTL 8100C / RTL 8110SC (optional) 10 / 100 / 1000 Mb/s Auto-Negotiation (Gigabit-Bandbreite nur beim RTL 8110SC) Halb-/Voll duplex-Funktion

	Ver 5.x		Ver 6.x	
Audio-Codec	ALC 888		ALC 861VD	
	7.1-Kanal-Audioausgabe		5.1-Kanal-Audioausgabe	
	Unterstützt High-Definition Audio		Unterstützt High-Definition Audio	
Steckplätze	PCI Express x16 Steckplatz (x4)	x1	PCI Express x16 Steckplatz (x4)	x1
	PCI-Steckplatz	x3	PCI-Steckplatz	x3
Onboard-Anschluss	Diskettenlaufwerkanschluss	x1	Diskettenlaufwerkanschluss	x1
	IDE-Anschluss	x1	IDE-Anschluss	x2
	Druckeranschluss Anschluss	x1	Druckeranschluss Anschluss	x1
	SATA-Anschluss	x4	SATA-Anschluss	x4
	Fronttafelanschluss	x1	Fronttafelanschluss	x1
	Front-Audioanschluss	x1	Front-Audioanschluss	x1
	CD-IN-Anschluss	x1	CD-IN-Anschluss	x1
	S/PDIF-Ausgangsanschluss (optional)	x1	S/PDIF-Ausgangsanschluss (optional)	x1
	S/PDIF Eingangsanschluss (optional)	x1	S/PDIF Eingangsanschluss (optional)	x1
	CPU-Lüfter-Sockel	x1	CPU-Lüfter-Sockel	x1
	System-Lüfter-Sockel	x1	System-Lüfter-Sockel	x1
	"Gehäuse offen"-Sockel (optional)	x1	"Gehäuse offen"-Sockel (optional)	x1
	"CMOS löschen"-Sockel	x1	"CMOS löschen"-Sockel	x1
	USB-Anschluss	x2	USB-Anschluss	x2
Stromanschluss (24-polig)	x1	Stromanschluss (24-polig)	x1	
Stromanschluss (4-polig)	x1	Stromanschluss (4-polig)	x1	
Rückseiten-E/A	PS/2-Tastatur	x1	PS/2-Tastatur	x1
	PS/2-Maus	x1	PS/2-Maus	x1
	Serieller Anschluss	x1	Serieller Anschluss	x1
	VGA-Anschluss	x1	VGA-Anschluss	x1
	LAN-Anschluss	x1	LAN-Anschluss	x1
	USB-Anschluss	x4	USB-Anschluss	x4
	Audioanschluss	x6	Audioanschluss	x3
Platinengröße	219 mm (B) X 235 mm (L)		219 mm (B) X 235 mm (L)	
OS-Unterstützung	Windows 2000 / XP / VISTA Biostar behält sich das Recht vor, ohne Ankündigung die Unterstützung für ein Betriebssystem hinzuzufügen oder zu entfernen.		Windows 2000 / XP / VISTA Biostar behält sich das Recht vor, ohne Ankündigung die Unterstützung für ein Betriebssystem hinzuzufügen oder zu entfernen.	

## FRANCE

	Ver 5.x	Ver 6.x
UC	LGA 775 Processeurs Intel Core2Duo / Pentium 4 / Pentium D / Celeron D jusqu'à 3,8 GHz (*It is recommended to use processors with 95W power consumption) Prend en charge les technologies Hyper-Threading d'exécution de bit de désactivation Intel SpeedStep® optimisée de mémoire étendue 64	LGA 775 Processeurs Intel Core2Duo / Pentium 4 / Pentium D / Celeron D jusqu'à 3,8 GHz (*It is recommended to use processors with 95W power consumption) Prend en charge les technologies Hyper-Threading d'exécution de bit de désactivation Intel SpeedStep® optimisée de mémoire étendue 64
Bus frontal	533 / 800 MHz	533 / 800 MHz
Chipset	Intel 945GZ Intel ICH7	Intel 945GZ Intel ICH7
Graphiques	Intel GMA 950 Mémoire vidéo partagée maximale de 192 Mo	Intel GMA 950 Mémoire vidéo partagée maximale de 192 Mo
Super E/S	ITE 8712F Moniteur de matériel Contrôleur de vitesse de ventilateur Fonction "Garden intelligent" de l'ITE	ITE 8712F Moniteur de matériel Contrôleur de vitesse de ventilateur Fonction "Garden intelligent" de l'ITE
Mémoire principale	Fentes DDR2 DIMM x 2 Chaque DIMM prend en charge des DDR2 de 256/512 Mo et 1Go Capacité mémoire maximale de 2 Go Module de mémoire DDR2 à mode à double voie Prend en charge la DDR2 400 / 533 Les DIMM à registres et DIMM avec code correcteurs d'erreurs ne sont pas prises en charge	Fentes DDR2 DIMM x 2 Chaque DIMM prend en charge des DDR2 de 256/512 Mo et 1Go Capacité mémoire maximale de 2 Go Module de mémoire DDR2 à mode à double voie Prend en charge la DDR2 400 / 533 Les DIMM à registres et DIMM avec code correcteurs d'erreurs ne sont pas prises en charge
IDE	Contrôleur IDE intégré Mode principale de Bus Ultra DMA 33 / 66 / 100 Prend en charge le mode PIO 0~4,	Contrôleur IDE intégré Mode principale de Bus Ultra DMA 33 / 66 / 100 Prend en charge le mode PIO 0~4,
SATA	Contrôleur Serial ATA intégré : Taux de transfert jusqu'à 3 Go/s. Conforme à la spécification SATA Version 2.0	Contrôleur Serial ATA intégré : Taux de transfert jusqu'à 3 Go/s. Conforme à la spécification SATA Version 2.0
LAN	Realtek RTL 8100C / RTL 8110SC (optional) 10 / 100 / 1000 Mb/s négociation automatique (La bande passante Gigabit est pour le RTL 8110SC uniquement) Half / Full duplex capability	Realtek RTL 8100C / RTL 8110SC (optional) 10 / 100 / 1000 Mb/s négociation automatique (La bande passante Gigabit est pour le RTL 8110SC uniquement) Half / Full duplex capability

	<i>Ver 5.x</i>		<i>Ver 6.x</i>	
Codec audio	ALC 888 Sortie audio à 7.1 voies Prise en charge de l'audio haute définition		ALC 861VD Sortie audio à 5.1 voies Prise en charge de l'audio haute définition	
Fentes	PCI Express x16 Steckplatz (x4)	x1	PCI Express x16 Steckplatz (x4)	x1
	Fente PCI	x3	Fente PCI	x3
Connecteur embarqué	Connecteur de disquette	x1	Connecteur de disquette	x1
	Connecteur IDE	x1	Connecteur IDE	x1
	Connecteur de Port d'imprimante	x1	Connecteur de Port d'imprimante	x1
	Connecteur SATA	x4	Connecteur SATA	x4
	Connecteur du panneau avant	x1	Connecteur du panneau avant	x1
	Connecteur Audio du panneau avant	x1	Connecteur Audio du panneau avant	x1
	Connecteur d'entrée CD	x1	Connecteur d'entrée CD	x1
	Connecteur d'entrée S/PDIF (en option)	x1	Connecteur d'entrée S/PDIF (en option)	x1
	Connecteur de sortie S/PDIF (en option)	x1	Connecteur de sortie S/PDIF (en option)	x1
	Embase de ventilateur UC	x1	Embase de ventilateur UC	x1
	Embase de ventilateur système	x1	Embase de ventilateur système	x1
	Embase d'ouverture de châssis (optional)	x1	Embase d'ouverture de châssis (optional)	x1
	Embase d'effacement CMOS	x1	Embase d'effacement CMOS	x1
Connecteur USB	x2	Connecteur USB	x2	
Connecteur d'alimentation (24 broches)	x1	Connecteur d'alimentation (24 broches)	x1	
Connecteur d'alimentation (4 broches)	x1	Connecteur d'alimentation (4 broches)	x1	
E/S du panneau arrière	Clavier PS/2	x1	Clavier PS/2	x1
	Souris PS/2	x1	Souris PS/2	x1
	Port série	x1	Port série	x1
	Port VGA	x1	Port VGA	x1
	Port LAN	x1	Port LAN	x1
	Port USB	x4	Port USB	x4
Fiche audio	x6	Fiche audio	x3	
Dimensions de la carte	219mm (l) X 235mm (H)		219mm (l) X 235mm (H)	
Support SE	Windows 2000 / XP / VISTA Biostar se réserve le droit d'ajouter ou de supprimer le support de SE avec ou sans préavis.		Windows 2000 / XP / VISTA Biostar se réserve le droit d'ajouter ou de supprimer le support de SE avec ou sans préavis.	

**ITALIAN**

	<i>Ver 5.x</i>	<i>Ver 6.x</i>
CPU	LGA 775 Processore Intel Core2Duo / Pentium 4 / Pentium D / Celeron D fino a 3.8 GHz (*It is recommended to use processors with 95W power consumption) Supporto di Hyper-Threading Execute Disable Bit Enhanced Intel SpeedStep® Tecnologia Extended Memory 64	LGA 775 Processore Intel Core2Duo / Pentium 4 / Pentium D / Celeron D fino a 3.8 GHz (*It is recommended to use processors with 95W power consumption) Supporto di Hyper-Threading Execute Disable Bit Enhanced Intel SpeedStep® Tecnologia Extended Memory 64
FSB	533 / 800 MHz	533 / 800 MHz
Chipset	Intel 945GZ Intel ICH7	Intel 945GZ Intel ICH7
Grafica	Intel GMA 950 La memoria videocondivisa massima è di 192MB	Intel GMA 950 La memoria videocondivisa massima è di 192MB
Super I/O	ITE 8712F Monitoraggio hardware Controller velocità ventolina Funzione "Smart Guardian" di ITE	ITE 8712F Monitoraggio hardware Controller velocità ventolina Funzione "Smart Guardian" di ITE
Memoria principale	Alloggi DIMM DDR 2 x 2 Ciascun DIMM supporta DDR2 256/512MB e 1GB Capacità massima della memoria a 2GB Modulo di memoria DDR2 a canale doppio Supporto di DDR2 400 / 533 DIMM registrati e DIMM ECC non sono supportati	Alloggi DIMM DDR 2 x 2 Ciascun DIMM supporta DDR2 256/512MB e 1GB Capacità massima della memoria a 2GB Modulo di memoria DDR2 a canale doppio Supporto di DDR2 400 / 533 DIMM registrati e DIMM ECC non sono supportati
IDE	Controller IDE integrato Modalità Bus Master Ultra DMA 33 / 66 / 100 Supporto modalità PIO Mode 0-4	Controller IDE integrato Modalità Bus Master Ultra DMA 33 / 66 / 100 Supporto modalità PIO Mode 0-4
SATA	Controller Serial ATA integrato Velocità di trasferimento dei dati fino a 3 Gb/s. Compatibile specifiche SATA Versione 2.0.	Controller Serial ATA integrato Velocità di trasferimento dei dati fino a 3 Gb/s. Compatibile specifiche SATA Versione 2.0.
LAN	Realtek RTL 8100C / RTL 8110SC (optional) Negoziazione automatica 10 / 100 / 1000 Mb/s (la larghezza di banda Gigabit è solo per RTL 8110SC) Capacità Half / Full Duplex	Realtek RTL 8100C / RTL 8110SC (optional) Negoziazione automatica 10 / 100 / 1000 Mb/s (la larghezza di banda Gigabit è solo per RTL 8110SC) Capacità Half / Full Duplex

	<i>Ver 5.x</i>		<i>Ver 6.x</i>	
Codec audio	ALC 888 Uscita audio 7.1 canali Supporto audio High-Definition (HD)		ALC 861VD Uscita audio 5.1 canali Supporto audio High-Definition (HD)	
Alloggi	Fente PCI Express x16 (x4)	x1	Fente PCI Express x16 (x4)	x1
	Alloggio PCI	x3	Alloggio PCI	x3
Connettori su scheda	Connettore floppy	x1	Connettore floppy	x1
	Connettore IDE	x1	Connettore IDE	x1
	Connettore Porta stampante	x1	Connettore Porta stampante	x1
	Connettore SATA	x4	Connettore SATA	x4
	Connettore pannello frontale	x1	Connettore pannello frontale	x1
	Connettore audio frontale	x1	Connettore audio frontale	x1
	Connettore CD-in	x1	Connettore CD-in	x1
	Connettore input S/PDIF (optional)	x1	Connettore input S/PDIF (optional)	x1
	Connettore output SPDIF (optional)	x1	Connettore output SPDIF (optional)	x1
	Collettore ventolina CPU	x1	Collettore ventolina CPU	x1
	Collettore ventolina sistema	x1	Collettore ventolina sistema	x1
	Collettore apertura telaio (optional)	x1	Collettore apertura telaio (optional)	x1
	Collettore cancellazione CMOS	x1	Collettore cancellazione CMOS	x1
Connettore USB	x2	Connettore USB	x2	
Connettore alimentazione (24 pin)	x1	Connettore alimentazione (24 pin)	x1	
Connettore alimentazione (4 pin)	x1	Connettore alimentazione (4 pin)	x1	
I/O pannello posteriore	Tastiera PS/2	x1	Tastiera PS/2	x1
	Mouse PS/2	x1	Mouse PS/2	x1
	Porta seriale	x1	Porta seriale	x1
	Porta VGA	x1	Porta VGA	x1
	Porta LAN	x1	Porta LAN	x1
	Porta USB	x4	Porta USB	x4
Connettore audio	x6	Connettore audio	x3	
Dimensioni scheda	219 mm (larghezza) x 235 mm (altezza)		219 mm (larghezza) x 235 mm (altezza)	
Sistemi operativi supportati	Windows 2000 / XP / VISTA Biostar si riserva il diritto di aggiungere o rimuovere il supporto di qualsiasi sistema operativo senza preavviso.		Windows 2000 / XP / VISTA Biostar si riserva il diritto di aggiungere o rimuovere il supporto di qualsiasi sistema operativo senza preavviso.	

**SPANISH**

	<i>Ver 5.x</i>	<i>Ver 6.x</i>
CPU	LGA 775 Procesador Intel Core2Duo / Pentium 4 / Pentium D / Celeron D hasta 3,8 GHz (*It is recommended to use processors with 95W power consumption ) Admite Hyper-Threading Bit de deshabilitación de ejecución Intel SpeedStep® Mejorado Tecnología Extended Memory 64	LGA 775 Procesador Intel Core2Duo / Pentium 4 / Pentium D / Celeron D hasta 3,8 GHz (*It is recommended to use processors with 95W power consumption ) Admite Hyper-Threading Bit de deshabilitación de ejecución Intel SpeedStep® Mejorado Tecnología Extended Memory 64
FSB	533 / 800 MHz	533 / 800 MHz
Conjunto de chips	Intel 945GZ Intel ICH7	Intel 945GZ Intel ICH7
Gráficos	Intel GMA 950 Memoria máxima de vídeo compartida de 192MB	Intel GMA 950 Memoria máxima de vídeo compartida de 192MB
Súper E/S	ITE 8712F Monitor hardware Controlador de velocidad de ventilador Función "Guarda inteligente" de ITE	ITE 8712F Monitor hardware Controlador de velocidad de ventilador Función "Guarda inteligente" de ITE
Memoria principal	Ranuras DIMM DDR2 x 2 Cada DIMM admite DDR2 de 256/512MB y 1GB Capacidad máxima de memoria de 2GB Módulo de memoria DDR2 de canal Doble Admite DDR2 de 400 / 533 No admite DIMM registrados o DIMM compatibles con ECC	Ranuras DIMM DDR2 x 2 Cada DIMM admite DDR2 de 256/512MB y 1GB Capacidad máxima de memoria de 2GB Módulo de memoria DDR2 de canal Doble Admite DDR2 de 400 / 533 No admite DIMM registrados o DIMM compatibles con ECC
IDE	Controlador IDE integrado Modo bus maestro Ultra DMA 33 / 66 / 100 Soporte los Modos PIO 0~4.	Controlador IDE integrado Modo bus maestro Ultra DMA 33 / 66 / 100 Soporte los Modos PIO 0~4.
SATA	Controlador ATA Serie Integrado Tasas de transferencia de hasta 3 Gb/s. Compatible con la versión SATA 2.0.	Controlador ATA Serie Integrado Tasas de transferencia de hasta 3 Gb/s. Compatible con la versión SATA 2.0.
Red Local	Realtek RTL 8100C / RTL 8110SC (opcional) Negociación de 10 / 100 / 1000 Mb/s (el ancho de banda Gigabit es únicamente para 8110SC) Funciones Half/ Full dúplex	Realtek RTL 8100C / RTL 8110SC (opcional) Negociación de 10 / 100 / 1000 Mb/s (el ancho de banda Gigabit es únicamente para 8110SC) Funciones Half/ Full dúplex



	Ver 5.x		Ver 6.x	
Códecs de sonido	ALC 888		ALC 861VD	
	Salida de sonido de 7.1 canales		Salida de sonido de 5.1 canales	
	Soporte de sonido Alta Definición		Soporte de sonido Alta Definición	
Ranuras	Ranura PCI Express x16 (x4)	X1	Ranura PCI Express x16 (x4)	X1
	Ranura PCI	X3	Ranura PCI	X3
Conectores en placa	Conector disco flexible	X1	Conector disco flexible	X1
	Conector IDE	X1	Conector IDE	X1
	Conector Puerto de impresora	X1	Conector Puerto de impresora	X1
	Conector SATA	X4	Conector SATA	X4
	Conector de panel frontal	X1	Conector de panel frontal	X1
	Conector de sonido frontal	X1	Conector de sonido frontal	X1
	Conector de entrada de CD	X1	Conector de entrada de CD	X1
	Conector de entrada S/PDIF (opcional)	x1	Conector de entrada S/PDIF (opcional)	x1
	Conector de salida S/PDIF (opcional)	X1	Conector de salida S/PDIF (opcional)	X1
	Cabecera de ventilador de CPU	X1	Cabecera de ventilador de CPU	X1
	Cabecera de ventilador de sistema	X1	Cabecera de ventilador de sistema	X1
	Cabecera de chasis abierto (opcional)	X1	Cabecera de chasis abierto (opcional)	X1
	Cabecera de borrado de CMOS	X1	Cabecera de borrado de CMOS	X1
	Conector USB	X2	Conector USB	X2
	Conector de alimentación (24 patillas)	X1	Conector de alimentación (24 patillas)	X1
	Conector de alimentación (4 patillas)	X1	Conector de alimentación (4 patillas)	X1
Panel trasero de E/S	Teclado PS/2	X1	Teclado PS/2	X1
	Ratón PS/2	X1	Ratón PS/2	X1
	Puerto serie	X1	Puerto serie	X1
	Puerto VGA	X1	Puerto VGA	X1
	Puerto de red local	X1	Puerto de red local	X1
	Puerto USB	X4	Puerto USB	X4
	Conector de sonido	X6	Conector de sonido	X3
Tamaño de la placa	219 mm. (A) X 235 mm. (H)		219 mm. (A) X 235 mm. (H)	
Soporte de sistema operativo	Windows 2000 / XP / VISTA Bióstar se reserva el derecho de añadir o retirar el soporte de cualquier SO con o sin aviso previo.		Windows 2000 / XP / VISTA Bióstar se reserva el derecho de añadir o retirar el soporte de cualquier SO con o sin aviso previo.	

**PORTUGUESE**

	<i>Ver 5.x</i>	<i>Ver 6.x</i>
CPU	LGA 775 Processador Intel Core2Duo / Pentium 4 / Pentium D / Celeron D até 3,8 GHz (*It is recommended to use processors with 95W power consumption.) Suporta as tecnologias Hyper-Threading Execute Disable Bit Enhanced Intel SpeedStep® Extended Memory 64	LGA 775 Processador Intel Core2Duo / Pentium 4 / Pentium D / Celeron D até 3,8 GHz (*It is recommended to use processors with 95W power consumption.) Suporta as tecnologias Hyper-Threading Execute Disable Bit Enhanced Intel SpeedStep® Extended Memory 64
FSB	533 / 800 MHz	533 / 800 MHz
Chipset	Intel 945GZ Intel ICH7	Intel 945GZ Intel ICH7
Placa gráfica	Intel GMA 950 Memória de vídeo máxima partilhada: 192 MB	Intel GMA 950 Memória de vídeo máxima partilhada: 192 MB
Especificação Super I/O	ITE 8712F Monitorização do hardware Controlador da velocidade da ventoinha Função "Smart Guardian" da ITE	ITE 8712F Monitorização do hardware Controlador da velocidade da ventoinha Função "Smart Guardian" da ITE
Memória principal	Ranuras DIMM DDR2 x2 Cada módulo DIMM suporta uma memória DDR2 de 256/512 MB & 1 GB Capacidade máxima de memória: 2 GB Módulo de memória DDR2 de canal duplo Suporta módulos DDR2 400 / 533 Os módulos DIMM registados e os DIMM ECC não são suportados	Ranuras DIMM DDR2 x2 Cada módulo DIMM suporta uma memória DDR2 de 256/512 MB & 1 GB Capacidade máxima de memória: 2 GB Módulo de memória DDR2 de canal duplo Suporta módulos DDR2 400 / 533 Os módulos DIMM registados e os DIMM ECC não são suportados
IDE	Controlador IDE integrado Modo Bus master Ultra DMA 33 / 66 / 100 Suporta o modo PIO 0~4.	Controlador IDE integrado Modo Bus master Ultra DMA 33 / 66 / 100 Suporta o modo PIO 0~4.
SATA	Controlador Serial ATA integrado Velocidades de transmissão de dados até 3 Gb/s. Compatibilidade com a especificação SATA versão 2.0.	Controlador Serial ATA integrado Velocidades de transmissão de dados até 3 Gb/s. Compatibilidade com a especificação SATA versão 2.0.
LAN	Realtek RTL 8100C / RTL 8110SC (opcional) Auto negociação de 10 / 100 / 1000 Mb/s (a largura de banda Ggabit refere-se apenas à especificação RTL 8110SC) Capacidade semi/full-duplex	Realtek RTL 8100C / RTL 8110SC (opcional) Auto negociação de 10 / 100 / 1000 Mb/s (a largura de banda Ggabit refere-se apenas à especificação RTL 8110SC) Capacidade semi/full-duplex

	<i>Ver 5.x</i>		<i>Ver 6.x</i>	
Codec de som	ALC 888 Saída de áudio de 7.1 canais Suporta a especificação High-Definition Audio		ALC 861VD Saída de áudio de 5.1 canais Suporta a especificação High-Definition Audio	
Ranhuras	Ranhura PCI Express x16 (x4)	x1	Ranhura PCI Express x16 (x4)	x1
	Ranhura PCI	x3	Ranhura PCI	x3
Conectores na placa	Conector da unidade de disquetes	x1	Conector da unidade de disquetes	x1
	Conector IDE	x1	Conector IDE	x1
	Conector da para impressora	x1	Conector da para impressora	x1
	Conector SATA	x4	Conector SATA	x4
	Conector do painel frontal	x1	Conector do painel frontal	x1
	Conector de áudio frontal	x1	Conector de áudio frontal	x1
	Conector para entrada de CDs	x1	Conector para entrada de CDs	x1
	Conector de entrada S/PDIF (opcional)	x1	Conector de entrada S/PDIF (opcional)	x1
	Conector de saída S/PDIF (opcional)	x1	Conector de saída S/PDIF (opcional)	x1
	Conector da verticinha da CPU	x1	Conector da verticinha da CPU	x1
	Conector da verticinha do sistema	x1	Conector da verticinha do sistema	x1
	Conector para detecção da abertura do chassis (opcional)	x1	Conector para detecção da abertura do chassis (opcional)	x1
	Conector para limpeza do CMOS	x1	Conector para limpeza do CMOS	x1
	Conector USB	x2	Conector USB	x2
	Conector de alimentação (24 pinos)	x1	Conector de alimentação (24 pinos)	x1
Conector de alimentação (4 pinos)	x1	Conector de alimentação (4 pinos)	x1	
Entradas/Saídas no painel traseiro	Teclado PS/2	x1	Teclado PS/2	x1
	Rato PS/2	x1	Rato PS/2	x1
	Porta série	x1	Porta série	x1
	Porta VGA	x1	Porta VGA	x1
	Porta LAN	x1	Porta LAN	x1
	Porta USB	x4	Porta USB	x4
	Tomada de áudio	x6	Tomada de áudio	x3
Tamanho da placa	219 mm (L) X 235 mm (A)		219 mm (L) X 235 mm (A)	
Sistemas operativos suportados	Windows 2000 / XP / VISTA A Biostar reserva-se o direito de adicionar ou remover suporte para qualquer sistema operativo com ou sem aviso prévio.		Windows 2000 / XP / VISTA A Biostar reserva-se o direito de adicionar ou remover suporte para qualquer sistema operativo com ou sem aviso prévio.	

**POLISH**

	<i>Ver 5.x</i>	<i>Ver 6.x</i>
Procesor	LGA 775 Procesor Intel Core2Duo / Pentium 4 / Pentium D / Celeron D do 3,8 GHz (*It is recommended to use processors with 95W power consumption ) Obsługa Hyper-Threading Execute Disable Bit Enhanced Intel SpeedStep® Extended Memory 64 Technology	LGA 775 Procesor Intel Core2Duo / Pentium 4 / Pentium D / Celeron D do 3,8 GHz (*It is recommended to use processors with 95W power consumption ) Obsługa Hyper-Threading Execute Disable Bit Enhanced Intel SpeedStep® Extended Memory 64 Technology
FSB	533 / 800 MHz	533 / 800 MHz
Chipset	Intel 945GZ Intel ICH7	Intel 945GZ Intel ICH7
Grafika	Intel GMA 950 Maks. wielkość współdzielonej pamięci video wynosi 192MB	Intel GMA 950 Maks. wielkość współdzielonej pamięci video wynosi 192MB
Pamięć główna	Gniazda DDR2 DIMM x 2 Każde gniazdo DIMM obsługuje moduły 256/512MB oraz 1GB DDR2 Maks. wielkość pamięci 2GB Moduł pamięci DDR2 z trybem podwójnego kanału Obsługa DDR2 400 / 533 Brak obsługi Registered DIMM oraz ECC DIMM	Gniazda DDR2 DIMM x 2 Każde gniazdo DIMM obsługuje moduły 256/512MB oraz 1GB DDR2 Maks. wielkość pamięci 2GB Moduł pamięci DDR2 z trybem podwójnego kanału Obsługa DDR2 400 / 533 Brak obsługi Registered DIMM oraz ECC DIMM
Super I/O	ITE 8712F Monitor H/W Kontroler prędkości wentylatora Funkcja ITE "Smart Guardian"	ITE 8712F Monitor H/W Kontroler prędkości wentylatora Funkcja ITE "Smart Guardian"
IDE	Zintegrowany kontroler IDE Ultra DMA 33 / 66 / 100 Tryb Bus Master obsługa PIO tryb 0~4	Zintegrowany kontroler IDE Ultra DMA 33 / 66 / 100 Tryb Bus Master obsługa PIO tryb 0~4
SATA	Zintegrowany kontroler Serial ATA Transfer danych do 3 Gb/s. Zgodność ze specyfikacją SATA w wersji 2.0.	Zintegrowany kontroler Serial ATA Transfer danych do 3 Gb/s. Zgodność ze specyfikacją SATA w wersji 2.0.
LAN	Realtek RTL 8100C / RTL 8110SC (opcja) 10 / 100 / 1000 Mb/s z automatyczną negocjacją szybkości (Pasmo gigabitowe wyłącznie dla RTL 8110SC) Działanie w trybie półowicznego / pełnego duplexu	Realtek RTL 8100C / RTL 8110SC (opcja) 10 / 100 / 1000 Mb/s z automatyczną negocjacją szybkości (Pasmo gigabitowe wyłącznie dla RTL 8110SC) Działanie w trybie półowicznego / pełnego duplexu

	Ver 5.x		Ver 6.x	
Kodek dźwiękowy	ALC 888 7.1 kanałowe wyjście audio Obsługa High-DefinitionAudio		ALC 861VD 5.1 kanałowe wyjście audio Obsługa High-DefinitionAudio	
Gniazda	Gniazdb PCI Express x16 (x4)	x1	Gniazdb PCI Express x16 (x4)	x1
	Gniazdb PCI	x3	Gniazdb PCI	x3
Złącza wbudowane	Złącze napędu dyskietek	x1	Złącze napędu dyskietek	x1
	Złącze IDE	x1	Złącze IDE	x1
	Złącze Port drukarki	x1	Złącze Port drukarki	x1
	Złącze SATA	x4	Złącze SATA	x4
	Złącze pętla przedniego	x1	Złącze pętla przedniego	x1
	Przednie złącze audio	x1	Przednie złącze audio	x1
	Złącze wejścia CD	x1	Złącze wejścia CD	x1
	Złącze wejścia S/PDIF (opcja)	x1	Złącze wejścia S/PDIF (opcja)	x1
	Złącze wyjścia S/PDIF (opcja)	x1	Złącze wyjścia S/PDIF (opcja)	x1
	Złącze główkowe wentylatora procesora	x1	Złącze główkowe wentylatora procesora	x1
	Złącze główkowe wentylatora systemowego	x1	Złącze główkowe wentylatora systemowego	x1
	Złącze główkowe otwarcia obudowy (opcja)	x1	Złącze główkowe otwarcia obudowy (opcja)	x1
	Złącze główkowe kasowania CMOS	x1	Złącze główkowe kasowania CMOS	x1
Złącze USB	x2	Złącze USB	x2	
Złącze zasilania (24 pinowe)	x1	Złącze zasilania (24 pinowe)	x1	
Złącze zasilania (4 pinowe)	x1	Złącze zasilania (4 pinowe)	x1	
Back Panel I/O	Klawiatura PS/2	x1	Klawiatura PS/2	x1
	Mysz PS/2	x1	Mysz PS/2	x1
	Port szeregowy	x1	Port szeregowy	x1
	Port VGA	x1	Port VGA	x1
	Port LAN	x1	Port LAN	x1
	Port USB	x4	Port USB	x4
	Gniazdb audio	x6	Gniazdb audio	x3
Wymiary płyty	219 mm (S) X 235 mm (W)		219 mm (S) X 235 mm (W)	
Obsługa systemu operacyjnego	Windows 2000 / XP / VISTA Biostar zastrzega sobie prawo dodawania lub odwoływania obsługi dowolnego systemu operacyjnego bez powiadomienia.		Windows 2000 / XP / VISTA Biostar zastrzega sobie prawo dodawania lub odwoływania obsługi dowolnego systemu operacyjnego bez powiadomienia.	

## RUSSIAN

	Ver 5.x	Ver 6.x
CPU (центральный процессор)	LGA 775 Процессор Intel Core2Duo / Pentium 4 / Pentium D / Celeron D до 3.8 ГГц (*It is recommended to use processors with 95W power consumption ) Поддержка технологий Hyper-Threading Execute Disable Bit Enhanced Intel SpeedStep® Extended Memory 64 Technology	LGA 775 Процессор Intel Core2Duo / Pentium 4 / Pentium D / Celeron D до 3.8 ГГц (*It is recommended to use processors with 95W power consumption ) Поддержка технологий Hyper-Threading Execute Disable Bit Enhanced Intel SpeedStep® Extended Memory 64 Technology
FSB	533 / 800 МГц	533 / 800 МГц
Набор микросхем	Intel 945GZ Intel ICH7	Intel 945GZ Intel ICH7
Графика	Intel GMA 950 Максимальная совместно используемая видеопамять составляет 192 МБ	Intel GMA 950 Максимальная совместно используемая видеопамять составляет 192 МБ
Основная память	Слоты DDR2 DIMM x 2 Каждый модуль DIMM поддерживает 256/512 МБ & 1 ГБ DDR2 Максимальная ёмкость памяти 2 ГБ Модуль памяти с двухканальным режимом DDR2 Поддержка DDR2 400 / 533 Не поддерживает зарегистрированные модули DIMM and ECC DIMM	Слоты DDR2 DIMM x 2 Каждый модуль DIMM поддерживает 256/512 МБ & 1 ГБ DDR2 Максимальная ёмкость памяти 2 ГБ Модуль памяти с двухканальным режимом DDR2 Поддержка DDR2 400 / 533 Не поддерживает зарегистрированные модули DIMM and ECC DIMM
Super I/O	ITE 8712F Аппаратный монитор Регулятор скорости Функция ITE "Smart Guardian" (Интеллектуальная защита)	ITE 8712F Аппаратный монитор Регулятор скорости Функция ITE "Smart Guardian" (Интеллектуальная защита)
IDE	Встроенное устройство управления встроенными интерфейсами устройств Режим "хвояина" шины Ultra DMA 33 / 66 / 100 Поддержка режима PIO 0~4,	Встроенное устройство управления встроенными интерфейсами устройств Режим "хвояина" шины Ultra DMA 33 / 66 / 100 Поддержка режима PIO 0~4,
SATA	Встроенное последовательное устройство управления ATA скорость передачи данных до 3 гигабит/с. Соответствие спецификации SATA версия 2.0.	Встроенное последовательное устройство управления ATA скорость передачи данных до 3 гигабит/с. Соответствие спецификации SATA версия 2.0.
Локальная сеть	Realtek RTL 8100C / RTL 8110SC (дополнительно) Автоматическое согласование 10 / 100 / 1000 Мб/с (гигабитная пропускная способность только для гигабитного физического уровня) Частичная / полная дуплексная способность	Realtek RTL 8100C / RTL 8110SC (дополнительно) Автоматическое согласование 10 / 100 / 1000 Мб/с (гигабитная пропускная способность только для гигабитного физического уровня) Частичная / полная дуплексная способность

	Ver 5.x		Ver 6.x	
Звуковой кодек	ALC888 Звуковая поддержка High-Definition 7.1 канальный звуковой выход		ALC861VD Звуковая поддержка High-Definition 5.1 канальный звуковой выход	
Слоты	Слот PCI Express x16 (x4)	x1	Слот PCI Express x16 (x4)	x1
	Слот PCI	x3	Слот PCI	x3
Встроенный разъем	Разъем НГМД	x1	Разъем НГМД	x1
	Разъем IDE	x1	Разъем IDE	x1
	Разъем Порт подключения принтера	x1	Разъем Порт подключения принтера	x1
	Разъем SATA	x4	Разъем SATA	x4
	Разъем на лицевой панели	x1	Разъем на лицевой панели	x1
	Входной звуковой разъем	x1	Входной звуковой разъем	x1
	Разъем ввода для CD	x1	Разъем ввода для CD	x1
	Разъем ввода для S/PDIF (дополнительно)	x1	Разъем ввода для S/PDIF (дополнительно)	x1
	Разъем вывода для S/PDIF (дополнительно)	x1	Разъем вывода для S/PDIF (дополнительно)	x1
	Контактирующее приспособление вентилятора центрального процессора	x1	Контактирующее приспособление вентилятора центрального процессора	x1
	Контактирующее приспособление вентилятора системы	x1	Контактирующее приспособление вентилятора системы	x1
	Шасси открытого контактирующего приспособления (дополнительно)	x1	Шасси открытого контактирующего приспособления (дополнительно)	x1
	Открытое контактирующее приспособление CMOS	x1	Открытое контактирующее приспособление CMOS	x1
	USB-разъем	x2	USB-разъем	x2
	Разъем питания (24 вывод)	x1	Разъем питания (24 вывод)	x1
Разъем питания (4 вывод)	x1	Разъем питания (4 вывод)	x1	
Задняя панель средств ввода-вывода	Клавиатура PS/2	x1	Клавиатура PS/2	x1
	Мышь PS/2	x1	Мышь PS/2	x1
	Последовательный порт	x1	Последовательный порт	x1
	Порт VGA	x1	Порт VGA	x1
	Порт LAN	x1	Порт LAN	x1
	USB-порт	x4	USB-порт	x4
Размер панели	219 мм (Ш) X 235 мм (В)		219 мм (Ш) X 235 мм (В)	
	219 мм (Ш) X 235 мм (В)		219 мм (Ш) X 235 мм (В)	
Поддержка OS	Windows 2000 / XP / VISTA Biostar сохраняет за собой право добавлять или удалять средства обеспечения для OS с или без предварительного уведомления.		Windows 2000 / XP / VISTA Biostar сохраняет за собой право добавлять или удалять средства обеспечения для OS с или без предварительного уведомления.	

## ARABIC

Ver 6.x	Ver 5.x	
LGA 775 Intel Core2Duo / Pentium 4 / Pentium D / Celeron D يتردد يصل إلى 3.8 جيجا هرتز (*It is recommended to use processors with 95W power consumption ) Hyper-Threading تدعم تنفيذ Execute Disable Bit Enhanced Intel SpeedStep® Extended Memory 64 Technology	LGA 775 Intel Core2Duo / Pentium 4 / Pentium D / Celeron D يتردد يصل إلى 3.8 جيجا هرتز (*It is recommended to use processors with 95W power consumption ) Hyper-Threading تدعم تنفيذ Execute Disable Bit Enhanced Intel SpeedStep® Extended Memory 64 Technology	وحدة المعالجة المركبة
ميغا هرتز 533 / 800 تردد	ميغا هرتز 533 / 800 تردد	النقل الأممي الجانبي
Intel 945GZ Intel ICH7	Intel 945GZ Intel ICH7	مجموعة لشراخ
Intel GMA 950 ميغا بايت 192 أقصى سعة لذاكرة لفيديو لمشوكة	Intel GMA 950 ميغا بايت 192 أقصى سعة لذاكرة لفيديو لمشوكة	بطاقة الرسومات
2 على DDR2 DIMM فتحة ميغا 256/512 سعة DDR2 تدعم ذاكرة من نوع DIMM تدعم كل فتحة بايت و 1 جيجا بايت سعة ذاكرة قصوى 2 جيجا بايت أحليبة مزوجة لفتحة DDR2 وحدة ذاكرة ميغا بايت 400 / 533 ساعات DDR2 تدعم الذاكرة من نوع ECC ونك التي لا تتوافق مع DIMM لا تدعم رقائق الذاكرة	2 على DDR2 DIMM فتحة ميغا 256/512 سعة DDR2 تدعم ذاكرة من نوع DIMM تدعم كل فتحة بايت و 1 جيجا بايت سعة ذاكرة قصوى 2 جيجا بايت أحليبة مزوجة لفتحة DDR2 وحدة ذاكرة ميغا بايت 400 / 533 ساعات DDR2 تدعم الذاكرة من نوع ECC ونك التي لا تتوافق مع DIMM لا تدعم رقائق الذاكرة	الذاكرة الرئيسية
ITE 8712F مرقب لمعومة حللة الأجهزة مرقب في سوعة لمروحة ITE من "Smart Guardian" وظيفة	ITE 8712F مرقب لمعومة حللة الأجهزة مرقب في سوعة لمروحة ITE من "Smart Guardian" وظيفة	Super I/O
متكامل IDE متحكم Ultra DMA 33 / 66 / 100 نقل بقتية وضع رئيسي PIO Mode 0~4 دعم وضع	متكامل IDE متحكم Ultra DMA 33 / 66 / 100 نقل بقتية وضع رئيسي PIO Mode 0~4 دعم وضع	منفذ IDE
متكامل Serial ATA متحكم قل البيانات بسرعات تصل إلى 3 جيجابت/ثانية. 2.0 الإصدار SATA مطابقة لمواصفات	متكامل Serial ATA متحكم قل البيانات بسرعات تصل إلى 3 جيجابت/ثانية. 2.0 الإصدار SATA مطابقة لمواصفات	SATA
Realtek RTL 8100C / RTL 8110SC (اختياري) قلووض قطني 100/10 ميغا بايت / ثنائية و 1 جيجابت/ثانية RTL 8110SC النطاق الترددي لجيجابت مقصور فقط على إمكانية النقل لمزوح الكامل/القصي	Realtek RTL 8100C / RTL 8110SC (اختياري) قلووض قطني 100/10 ميغا بايت / ثنائية و 1 جيجابت/ثانية RTL 8110SC النطاق الترددي لجيجابت مقصور فقط على إمكانية النقل لمزوح الكامل/القصي	شبكة داخلية 100/10



Ver 6.x		Ver 5.x			
ALC861VD	قنوات لخرج الصوت 1, 5.	ALC888	قنوات لخرج الصوت 1, 7.	كوديك الصوت	
تدعم تقنية لصوت علي تعريف من		تدعم تقنية لصوت علي تعريف من			
عدد 1	فتحة PCI Express x16 (x4)	عدد 1	فتحة PCI Express x16 (x4)	الفتحات	
عدد 3	فتحة PCI	عدد 3	فتحة PCI		
عدد 1	مقذ محرك أقراص مرنة	عدد 1	مقذ محرك أقراص مرنة	المنافذ على سطح اللوحة	
عدد 1	مقذ IDE	عدد 1	مقذ IDE		
عدد 1	مقذ طابعة	عدد 1	مقذ طابعة		
عدد 4	مقذ SATA	عدد 4	مقذ SATA		
عدد 1	مقذ اللوحة الأممية	عدد 1	مقذ اللوحة الأممية		
عدد 1	مقذ الصوت الأممي	عدد 1	مقذ الصوت الأممي		
عدد 1	مقذ CD-IN	عدد 1	مقذ CD-IN		
عدد 1	مقذ دخل S/PDIF (اختياري)	عدد 1	مقذ دخل S/PDIF (اختياري)		
عدد 1	مقذ خرج S/PDIF (اختياري)	عدد 1	مقذ خرج S/PDIF (اختياري)		
	وصلة مروحة وحدة المعالجة		وصلة مروحة وحدة المعالجة		
عدد 1	المركزية	عدد 1	المركزية		
عدد 1	وصلة مروحة للظلم	عدد 1	وصلة مروحة للظلم		
عدد 1	وصلة فتح الهيكل (اختياري)	عدد 1	وصلة فتح الهيكل (اختياري)		
عدد 1	وصلة مسح CMOS	عدد 1	وصلة مسح CMOS		
عدد 2	مقذ USB	عدد 2	مقذ USB		
عدد 1	مقذ توصيل الطاقة (24دوس)	عدد 1	مقذ توصيل الطاقة (24دوس)		
عدد 1	مقذ توصيل الطاقة (4دبليس)	عدد 1	مقذ توصيل الطاقة (4دبليس)		
عدد 1	لوحة مفاتيح PS/2	عدد 1	لوحة مفاتيح PS/2		منافذ دخل/خرج اللوحة الخلفية
عدد 1	مؤس PS/2	عدد 1	مؤس PS/2		
عدد 1	مقذ تسلسلي	عدد 1	مقذ تسلسلي		
عدد 1	مقذ VGA	عدد 1	مقذ VGA		
عدد 1	مقذ شبكة تصل محلية	عدد 1	مقذ شبكة تصل محلية		
عدد 4	منافذ USB	عدد 4	منافذ USB		
عدد 3	مقيس صوت	عدد 6	مقيس صوت		
219 مم (عرض) X 235 مم (ارتفاع)		219 مم (عرض) X 235 مم (ارتفاع)		حجم اللوحة	
Windows 2000 / XP / VISTA	بحقها في إضافة أو إزالة ادم ابي نظام تشغيل باخطل أو Biostar تحفظ بيون اخطل.	Windows 2000 / XP / VISTA	بحقها في إضافة أو إزالة ادم ابي نظام تشغيل باخطل أو Biostar تحفظ بيون اخطل.	دعم أنظمة تشغيل	

## JAPANESE

	Ver 5.x	Ver 6.x
CPU	LGA 775 Intel Core2Duo / Pentium 4 / Pentium D / Celeron D processor up to 3.8 GHz (*It is recommended to use processors with 95W power consumption ) Hyper-Threading Execute Disable Bit Enhanced Intel SpeedStep® Extended Memory 64 Technology	LGA 775 Intel Core2Duo / Pentium 4 / Pentium D / Celeron D processor up to 3.8 GHz (*It is recommended to use processors with 95W power consumption ) Hyper-Threading Execute Disable Bit Enhanced Intel SpeedStep® Extended Memory 64 Technology
FSB	533 / 800 MHz	533 / 800 MHz
チップセット	Intel 945GZ Intel ICH7	Intel 945GZ Intel ICH7
グラフィックス	Intel GMA 950 最大の共有ビデオメモリは192MBです	Intel GMA 950 最大の共有ビデオメモリは192MBです
メインメモリ	DDR2 DIMMスロット x 2 各DIMMは256/512MB & 1GB DDR2をサポート 最大メモリ容量2GB デュアルチャンネルモードDDR2メモリモジュール DDR2 400 / 533 をサポート 登録済みDIMMとECC DIMMはサポートされません	DDR2 DIMMスロット x 2 各DIMMは256/512MB & 1GB DDR2をサポート 最大メモリ容量2GB デュアルチャンネルモードDDR2メモリモジュール DDR2 400 / 533 をサポート 登録済みDIMMとECC DIMMはサポートされません
Super I/O	ITE 8712F H/Wモニター ファン速度コントローラ / モニター ITEの「スマートガーディアン」機能	ITE 8712F H/Wモニター ファン速度コントローラ / モニター ITEの「スマートガーディアン」機能
IDE	統合IDEコントローラ Ultra DMA 33 / 66 / 100バスマスタモード PIO Mode 0~4のサポート	統合IDEコントローラ Ultra DMA 33 / 66 / 100バスマスタモード PIO Mode 0~4のサポート
SATA	統合シリアルATAコントローラ 最高3 Gb/秒のデータ転送速度 SATAバージョン2.0仕様に準拠。	統合シリアルATAコントローラ 最高3 Gb/秒のデータ転送速度 SATAバージョン2.0仕様に準拠。
10/100 LAN	Realtek RTL 8100C / RTL 8110SC(オプション) 10 / 100 / 1000 Mb/秒のオートネゴシエーション (Gigabitバンド幅はRTL 8110SC専用です) 半/全二重機能	Realtek RTL 8100C / RTL 8110SC(オプション) 10 / 100 / 1000 Mb/秒のオートネゴシエーション (Gigabitバンド幅はRTL 8110SC専用です) 半/全二重機能

	Ver 5.x		Ver 6.x	
サウンド Codec	ALC 888 7.1チャンネルオーディオアウト ハイデフィニションオーディオのサポート		ALC 861VD 5.1チャンネルオーディオアウト ハイデフィニションオーディオのサポート	
スロット	PCI Express x16スロット(x4)	x1	PCI Express x16スロット(x4)	x1
	PCIスロット	x3	PCIスロット	x3
オンボードコ ネクタ	フロッピーコネクタ	x1	フロッピーコネクタ	x1
	IDEコネクタ	x1	IDEコネクタ	x1
	プリンタポートコネクタ	x1	プリンタポートコネクタ	x1
	SATAコネクタ	x4	SATAコネクタ	x4
	フロントパネルコネクタ	x1	フロントパネルコネクタ	x1
	フロントオーディオコネクタ	x1	フロントオーディオコネクタ	x1
	CDインコネクタ	x1	CDインコネクタ	x1
	S/PDIFインコネクタ (オプション)	x1	S/PDIFインコネクタ (オプション)	x1
	S/PDIFアウトコネクタ(オプション)	x1	S/PDIFアウトコネクタ(オプション)	x1
	CPUファンヘッダ	x1	CPUファンヘッダ	x1
	システムファンヘッダ	x1	システムファンヘッダ	x1
	シャーシオープンヘッダ(オプション)	x1	シャーシオープンヘッダ(オプション)	x1
	CMOS クリアヘッダ	x1	CMOS クリアヘッダ	x1
	USBコネクタ	x2	USBコネクタ	x2
	電源コネクタ(24ピン)	x1	電源コネクタ(24ピン)	x1
	電源コネクタ(4ピン)	x1	電源コネクタ(4ピン)	x1
背面パネル I/O	PS/2キーボード	x1	PS/2キーボード	x1
	PS/2マウス	x1	PS/2マウス	x1
	シリアルポート	x1	シリアルポート	x1
	VGAポート	x1	VGAポート	x1
	LANポート	x1	LANポート	x1
	USBポート	x4	USBポート	x4
	オーディオジャック	x6	オーディオジャック	x3
ボードサイズ	219 mm (幅) X 235 mm (高さ)		219 mm (幅) X 235 mm (高さ)	
OSサポート	Windows 2000 / XP / VISTA Biostarは事前のサポートなしにOSサポートを追加ま たは削除する権利を留保します。		Windows 2000 / XP / VISTA Biostarは事前のサポートなしにOSサポートを追加ま たは削除する権利を留保します。	

2006/12/18

## **945GZ Micro 775 SE BIOS SETUP**

---

---

<b>BIOS Setup</b> .....	<b>1</b>
1 Main Menu.....	3
2 Standard CMOS Features .....	6
3 Advanced BIOS Features .....	8
4 Advanced Chipset Features.....	14
5 Integrated Peripherals .....	18
6 Power Management Setup .....	23
7 PnP/PCI Configurations .....	28
8 PC Health Status.....	30
9 Performance Booster Zone.....	32

# BIOS Setup

### Introduction

This manual discussed Award™ Setup program built into the ROM BIOS. The Setup program allows users to modify the basic system configuration. This special information is then stored in battery-backed RAM so that it retains the Setup information when the power is turned off.

The Award BIOS™ installed in your computer system's ROM (Read Only Memory) is a custom version of an industry standard BIOS. This means that it supports Intel Pentium® 4 processor input/output system. The BIOS provides critical low-level support for standard devices such as disk drives and serial and parallel ports.

Adding important has customized the Award BIOS™, but nonstandard, features such as virus and password protection as well as special support for detailed fine-tuning of the chipset controlling the entire system.

The rest of this manual is intended to guide you through the process of configuring your system using Setup.

### Plug and Play Support

These AWARD BIOS supports the Plug and Play Version 1.0A specification. ESCD (Extended System Configuration Data) write is supported.

### EPA Green PC Support

This AWARD BIOS supports Version 1.03 of the EPA Green PC specification.

### APM Support

These AWARD BIOS supports Version 1.1&1.2 of the Advanced Power Management (APM) specification. Power management features are implemented via the System Management Interrupt (SMI). Sleep and Suspend power management modes are supported. Power to the hard disk drives and video monitors can be managed by this AWARD BIOS.

### ACPI Support

Award ACPI BIOS support Version 1.0b of Advanced Configuration and Power interface specification (ACPI). It provides ASL code for power management and device configuration capabilities as defined in the ACPI specification, developed by Microsoft, Intel and Toshiba.

---

## 945GZ Micro 775 SE

---

### PCI Bus Support

This AWARD BIOS also supports Version 3.0 of the Intel PCI (Peripheral Component Interconnect) local bus specification.

### DRAM Support

DDR2 SDRAM (Double Data Rate Two Synchronous DRAM) are supported.

### Supported CPUs

This AWARD BIOS supports the Intel CPU.

### Using Setup

In general, you use the arrow keys to highlight items, press <Enter> to select, use the <PgUp> and <PgDn> keys to change entries, press <F1> for help and press <Esc> to quit. The following table provides more detail about how to navigate in the Setup program by using the keyboard.

Keystroke	Function
Up arrow	Move to previous item
Down arrow	Move to next item
Left arrow	Move to the item on the left (menu bar)
Right arrow	Move to the item on the right (menu bar)
Move Enter	Move to the item you desired
PgUp key	Increase the numeric value or make changes
PgDn key	Decrease the numeric value or make changes
+ Key	Increase the numeric value or make changes
- Key	Decrease the numeric value or make changes
Esc key	Main Menu – Quit and not save changes into CMOS Status Page Setup Menu and Option Page Setup Menu – Exit Current page and return to Main Menu
F1 key	General help on Setup navigation keys
F5 key	Load previous values from CMOS
F7 key	Load the optimized defaults
F10 key	Save all the CMOS changes and exit

---

## 945GZ Micro 775 SE

---

### 1 Main Menu

Once you enter Award BIOS™ CMOS Setup Utility, the Main Menu will appear on the screen. The Main Menu allows you to select from several setup functions. Use the arrow keys to select among the items and press <Enter> to accept and enter the sub-menu.

**!! WARNING !!**

The information about BIOS defaults on manual (Figure 1,2,3,4,5,6,7,8,9) is just for reference, please refer to the BIOS installed on board, for update information.

■ **Figure 1. Main Menu**

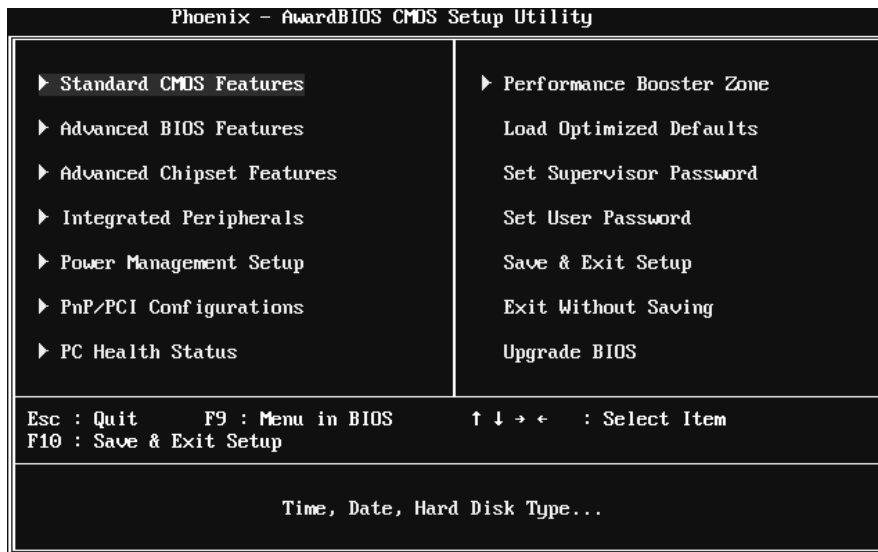

#### Standard CMOS Features

This submenu contains industry standard configurable options.

#### Advanced BIOS Features

This submenu allows you to configure enhanced features of the BIOS.

#### Advanced Chipset Features

This submenu allows you to configure special chipset features.

## 945GZ Micro 775 SE

---

### Integrated Peripherals

This submenu allows you to configure certain IDE hard drive options and Programmed Input/Output features.

### Power Management Setup

This submenu allows you to configure the power management features.

### PnP/PCI Configurations

This submenu allows you to configure certain “Plug and Play” and PCI options.

### PC Health Status

This submenu allows you to monitor the hardware of your system.

### Performance Booster Zone

This submenu allows you to change CPU Vcore Voltage and CPU/PCI clock. **(However, this function is strongly recommended not to use. Not properly change the voltage and clock may cause the CPU or M/B damage!)**

### Load Optimized Defaults

This selection allows you to reload the BIOS when the system is having problems particularly with the boot sequence. These configurations are factory settings optimized for this system. A confirmation message will be displayed before defaults are set.

```
Load Optimized Defaults <Y/N>? N
```

### Set Supervisor Password

Setting the supervisor password will prohibit everyone except the supervisor from making changes using the CMOS Setup Utility. You will be prompted with to enter a password.

```
Enter Password:
```



---

## 945GZ Micro 775 SE

---

### Set User Password

If the Supervisor Password is not set, then the User Password will function in the same way as the Supervisor Password. If the Supervisor Password is set and the User Password is set, the "User" will only be able to view configurations but will not be able to change them.

```
Enter Password:
```

### Save & Exit Setup

Save all configuration changes to CMOS (memory) and exit setup. Confirmation message will be displayed before proceeding.

```
SAVE to CMOS and EXIT <Y/N>? N
```

### Exit Without Saving

Abandon all changes made during the current session and exit setup. Confirmation message will be displayed before proceeding.

```
Quit Without Saving <Y/N>? N
```

### Upgrade BIOS

This submenu allows you to upgrade bios.

```
BIOS UPDATE UTILITY <Y/N>? N
```

## 945GZ Micro 775 SE

### 2 Standard CMOS Features

The items in Standard CMOS Setup Menu are divided into 10 categories. Each category includes no, one or more than one setup items. Use the arrow keys to highlight the item and then use the <PgUp> or <PgDn> keys to select the value you want in each item.

■ **Figure 2. Standard CMOS Setup**

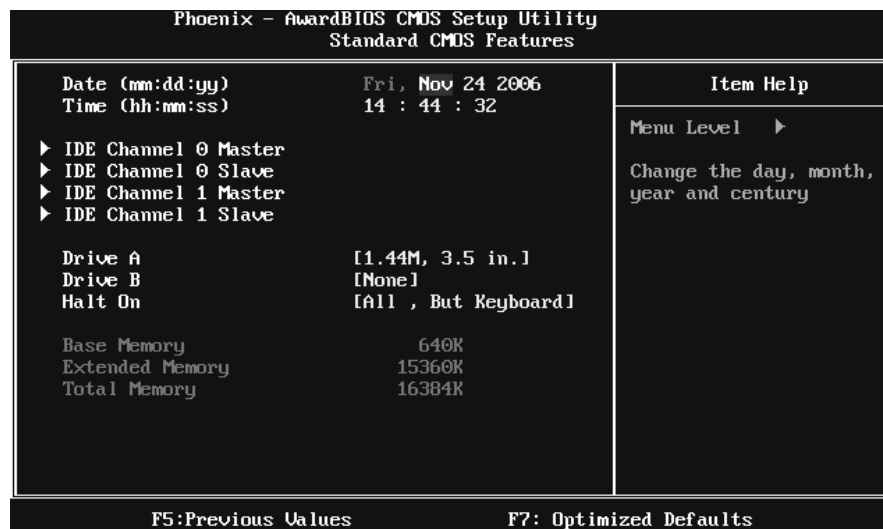

#### Main Menu Selections

This table shows the selections that you can make on the Main Menu.

Item	Options	Description
Date	mm : dd : yy	Set the system date. Note that the 'Day' automatically changes when you set the date.
Time	hh : mm : ss	Set the system internal clock.
IDE Channel 0 Master	Options are in its sub menu.	Press <Enter> to enter the sub menu of detailed options
IDE Channel 0 Slave	Options are in its sub menu.	Press <Enter> to enter the sub menu of detailed options.

---

## 945GZ Micro 775 SE

---

Item	Options	Description
IDE Channel 1 Master	Options are in its sub menu.	Press <Enter> to enter the sub menu of detailed options.
IDE Channel 1 Slave	Options are in its sub menu.	Press <Enter> to enter the sub menu of detailed options.
Drive A Drive B	360K, 5.25 in 1.2M, 5.25 in 720K, 3.5 in 1.44M, 3.5 in 2.88M, 3.5 in None	Select the type of floppy disk drive installed in your system.
Halt On	All Errors No Errors All, but Key board All, but Diskette All, but Disk/ Key	Select the situation in which you want the BIOS to stop the POST process and notify you.
Base Memory	N/A	Displays the amount of conventional memory detected during boot up.
Extended Memory	N/A	Displays the amount of extended memory detected during boot up.
Total Memory	N/A	Displays the total memory available in the system.

### 3 Advanced BIOS Features

■ Figure 3. Advanced BIOS Setup

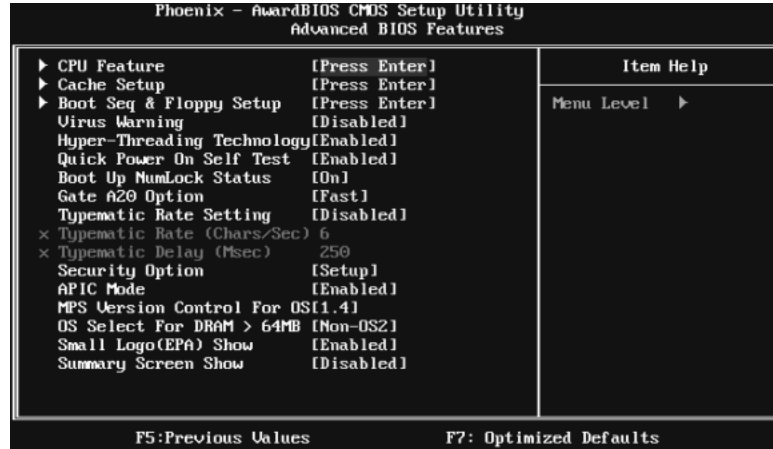

#### CPU FEATURE

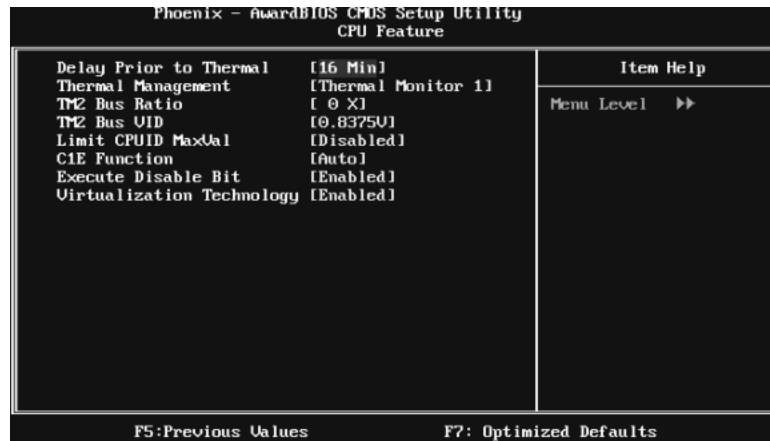

#### **Delay Prior to Thermal**

Set this item to enable the CPU Thermal function to engage after the specified time.

**The Choices:** 4 Min, 8 Min, 16 Min (default), 32 Min.

---

---

## 945GZ Micro 775 SE

---

---

### Thermal Management

This option allows you to choose the thermal management method of your monitor.

**The Choices:** Thermal Monitor 1 (default), Thermal Monitor 2.

**Notes:** The choices will be different according to your CPU features.

### TM2 Bus Ratio

This option represents the frequency. (Bus ratio of the throttled performance state that will be initiated when the on-die sensor goes from not hot to hot.)

Min=0 Max=255 Key in a DEC number.

**The Choices:** 0X (default).

### TM2 Bus VID

This option represents the voltage of the throttled performance state that will be initiated when the on-die sensor goes from not hot to hot.

**The Choices:** 0.8375V (default), 0.8375V-1.6000V.

### Limit CPUID MaxVal

Set limit CPUID MaxVal to 3, it should be "Disabled" for Win XP.

**The Choices:** Disabled (default), Enabled.

### C1E Function

This item allows you to choose the C1E function.

**The Choices:** Auto (default), Disabled.

### Execute Disable Bit

When disabled, forces the XD feature flag to always return 0.

**The Choices:** Enabled (default), Disabled.

### Virtualization Technology

When enabled, a VMM can utilize the additional hardware capabilities provided by Vanderpool Technology.

**The Choices:** Enabled (default), Disabled

---

## 945GZ Micro 775 SE

---

### Cache Setup

Phoenix - AwardBIOS CMOS Setup Utility	
Cache Setup	
CPU L3 Cache	[Enabled]
	Item Help
	Menu Level >>
F5: Previous Values      F7: Optimized Defaults	

### CPU L3 Cache

Depending on the CPU/chipset in use, you may be able to increase memory access time with this option.

**Enabled** (default)      Enable cache.  
Disabled                Disable cache.

### Boot Seq & Floppy Setup

This item allows you to setup Boot Seq & Floppy.

Phoenix - AwardBIOS CMOS Setup Utility	
Boot Seq & Floppy Setup	
▶ Hard Disk Boot Priority	[Press Enter]
First Boot Device	[Floppy]
Second Boot Device	[Hard Disk]
Third Boot Device	[CDROM]
Boot Other Device	[Enabled]
Swap Floppy Drive	[Disabled]
Boot Up Floppy Seek	[Enabled]
Report No FDD For WIN 95	[No]
	Item Help
	Menu Level >>
	Select Hard Disk Boot Device Priority
F5: Previous Values      F7: Optimized Defaults	

---

## 945GZ Micro 775 SE

---

### Hard Disk Boot Priority

These BIOS attempt to arrange the Hard Disk boot sequence automatically.

This will depend on which Hard Disk is installed.

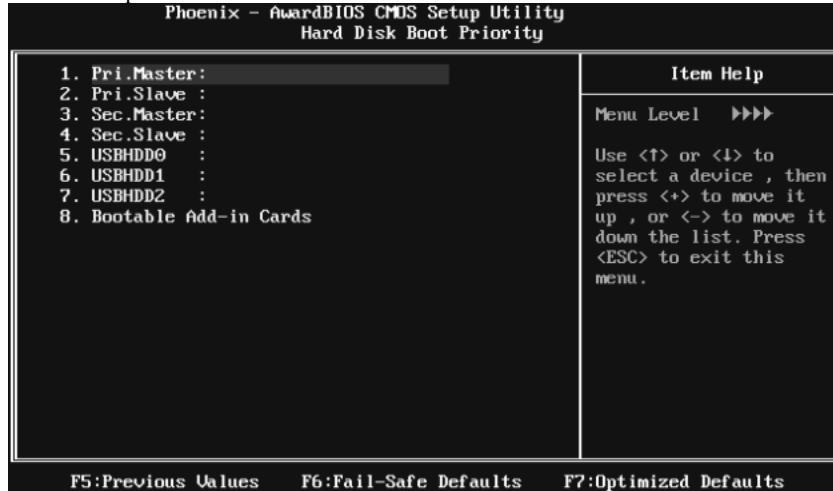

**The Choices:** Pri. Master, Pri.Slave, Sec.Master, Sec.Slave, USBHDD0, USBHDD1, USBHDD2 and Bootable Add-in Cards.

### First/Second/Third Boot Device

These BIOS attempt to load the operating system from the device in the sequence selected in these items.

**The Choices:** Floppy, LSI20, Hard Disk, CDROM, ZIP100, USB-FDD, USB-ZIP, USB-CDROM, LAN, Disabled.

### Boot Other Device

When enabled, BIOS will try to load the operating system from other device when it failed to load from the three devices above.

**The Choices:** Enabled (default), Disabled

### Swap Floppy Drive

For systems with two floppy drives, this option allows you to swap logical drive assignments.

**The Choices:** Disabled (default), Enabled.

### Boot Up Floppy Seek

Enabling this option will test the floppy drives to determine if they have 40 or 80 tracks. Disabling this option reduces the time it takes to boot-up.

**The Choices:** Disabled, Enabled (default).

---

## 945GZ Micro 775 SE

---

**Report NO FDD for Win95**  
**The Choices:** NO (default), YES.

### **Virus Warning**

This option allows you to choose the Virus Warning feature that is used to protect the IDE Hard Disk boot sector. If this function is enabled and an attempt is made to write to the boot sector, BIOS will display a warning message on the screen and sound an alarm beep.

<b>Disabled</b> (default)	Virus protection is disabled.
Enabled	Virus protection is activated.

### **Hyper-Threading Technology**

This option allows you to enable or disable CPU Hyper-Threading. "Enabled" for Windows XP and Linux 2.4.x (OS optimized for Hyper-Threading Technology.) "Disabled" for other OS (OS not optimized for Hyper-Threading Technology.)  
**The Choices:** Enabled (default), Disabled.

### **Quick Power On Self Test**

Enabling this option will cause an abridged version of the Power On Self Test (POST) to execute after you power up the computer.

Disabled	Normal POST.
<b>Enabled</b> (default)	Enable quick POST.

### **Boot Up NumLock Status**

Selects the NumLock State after power on.

<b>On</b> (default)	Numpad is arrow keys.
Off	Numpad is number keys.

### **Gate A20 Option**

Select if chipset or keyboard controller should control Gate A20.

Normal	A pin in the keyboard controller controls Gate A20.
<b>Fast</b> (default)	Lets chipset control Gate A20.

### **Typematic Rate Setting**

When a key is held down, the keystroke will repeat at a rate determined by the keyboard controller. When enabled, the typematic rate and typematic delay can be configured.

**The Choices:** Disabled (default), Enabled.

### **Typematic Rate (Chars/Sec)**

Sets the rate at which a keystroke is repeated when you hold the key down.

**The Choices:** 6 (default), 8, 10, 12, 15, 20, 24, 30



---

## 945GZ Micro 775 SE

---

### **Typematic Delay (Msec)**

Sets the delay time after the key is held down before it begins to repeat the keystroke.

**The Choices:** 250 (default), 500, 750, and 1000.

### **Security Option**

This option will enable only individuals with passwords to bring the system online and/or to use the CMOS Setup Utility.

**System** A password is required for the system to boot and is also required to access the Setup Utility.

**Setup (default)** A password is required to access the Setup Utility only.

*This will only apply if passwords are set from the Setup main menu.*

### **APIC Mode**

Selecting Enabled enables APIC device mode reporting from the BIOS to the operating system.

**The Choices:** Enabled (default), Disabled.

### **MPS Version Control For OS**

The BIOS supports version 1.1 and 1.4 of the Intel multiprocessor specification. Select version supported by the operation system running on this computer.

**The Choices:** 14 (default), 1.1.

### **OS Select For DRAM > 64MB**

A choice other than Non-OS2 is only used for OS2 systems with memory exceeding 64MB.

**The Choices:** Non-OS2 (default), OS2.

### **Small Logo (EPA) Show**

This item allows you to select whether the "Small Logo" shows.

**Enabled (default)** "Small Logo" shows when system boot up.

**Disabled** No "Small Logo" shows when system boots up.

### **Summary Screen Show**

This item allows you to enable/disable the summary screen. Summary screen means system configuration and PCI device listing.

**The Choices:** Enabled, Disabled (default).

### 4 Advanced Chipset Features

This submenu allows you to configure the specific features of the chipset installed on your system. This chipset manage bus speeds and access to system memory resources, such as DRAM. It also coordinates communications with the PCI bus. The default settings that came with your system have been optimized and therefore should not be changed unless you are suspicious that the settings have been changed incorrectly.

■ **Figure 4. Advanced Chipset Setup**

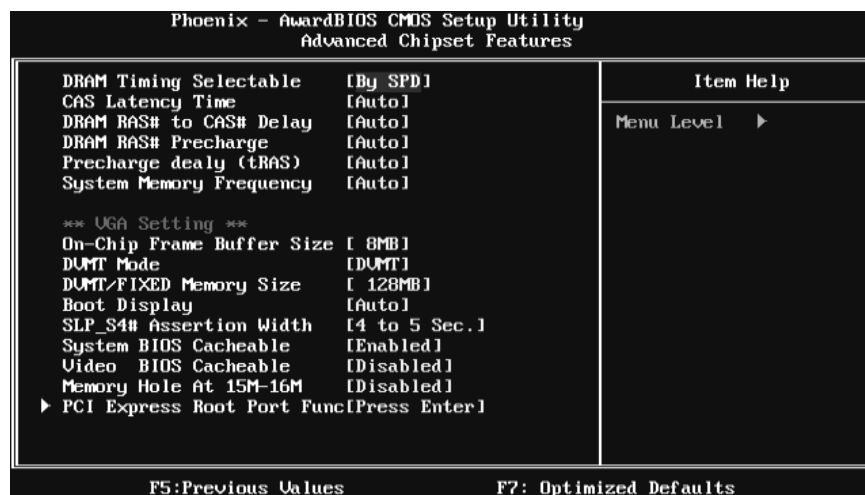

**DRAM Timing Selectable**

When synchronous DRAM is installed, the number of clock cycles of CAS latency depends on the DRAM timing.

**The Choices:** By SPD (default), Manual.

**CAS Latency Time**

When synchronous DRAM is installed, the number of clock cycles of CAS latency depends on the DRAM timing.

**The Choices:** Auto (default), 3, 4, 5, 6.

**DRAM RAS# to CAS# Delay**

This field let you insert a timing delay between the CAS and RAS strobe signals, used when DRAM is written to, read from, or refreshed. Fast gives faster performance; and slow gives more stable performance. This field applies only when synchronous DRAM is installed in the system.

**The Choices:** Auto (default), 2, 3, 4, 5, 6.

---

## 945GZ Micro 775 SE

---

### **DRAM RAS# Precharge**

If an insufficient number of cycles is allowed for RAS to accumulate its charge before DRAM refresh, the refresh may be incomplete, and the DRAM may fail to retain data. Fast gives faster performance; and Slow gives more stable performance. This field applies only when synchronous DRAM is installed in the system.

**The Choices:** Auto (default), 2, 3, 4, 5, 6.

### **Precharge Delay (TRAS)**

This item controls the number of DRAM clocks to activate the precharge delay.

**The Choices:** Auto (default), 4/5/6/7/8/9/10/11/12/13/14/15.

### **System Memory Frequency**

This item allows you to select the Memory Frequency.

**The Choices:** Auto (default), 400MHz, 533MHz, and 667MHz.

### **VGA Setting**

#### **On-Chip Frame Buffer Size**

This item will be different as your memory modules. When the memory size is decided, this frame buffer size will also be fixed.

**The Choices:** 8MB (default), 1MB.

#### **DVMT Mode**

**The Choices:** DVMT (default), FIXED, BOTH.

#### **DVMT/FIXED Memory Size**

DVMT stands for „Dynamic Video Memory Technology“. This is an enhancement of the unified memory architecture (UMA) concept. Where the optimum amount of memory is allocated for balanced graphics and system performance. DVMT dynamically responds to system requirements and applications demands, by allocating the proper amount of display, texturing and buffer memory after the operating system has booted.

**The Choices:** 128MB (Default), 64MB.

#### **Boot Display**

**The Choices:** Auto (default), CRT, TV, EFP.

#### **SLP S4# Assertion Width**

This item sets the minimum assertion width of the SLP-S4# signal to guarantee the DRAM has been safely power-cycled.

**The Choices:** 4 to 5 Sec. (default), 3 to 4 Sec., 2 to 3 Sec., 1 to 2 Sec.

## **945GZ Micro 775 SE**

---

### **System BIOS Cacheable**

Selecting Enabled allows you caching of the system BIOS ROM at F0000h~FFFFFh, resulting a better system performance. However, if any program writes to this memory area, a system error may result.

**The Choices:** Enabled (default), Disabled.

### **Video BIOS Cacheable**

Select Enabled allows caching of the video BIOS, resulting a better system performance. However, if any program writes to this memory area, a system error may result.

**The Choices:** Disabled (default), Enabled.

### **Memory Hole At 15M-16M**

You can reserve this area of system memory for ISA adapter ROM. When this area is reserved it cannot be cached. The user information of peripherals that need to use this area of system memory usually discussed their memory requirements.

**The Choices:** Disabled (default), Enabled.

---

## 945GZ Micro 775 SE

---

### PCI Express Root Port Func

Phoenix - AwardBIOS CMOS Setup Utility	
PCI Express Root Port Func	
PCI Express Port 1	[Auto]
PCI-E Compliancy Mode	[v1.0a]
	Item Help
	Menu Level >>

F5: Previous Values      F7: Optimized Defaults

#### **PCI Express Port 1**

This item allows you to select the PCI Express Port.

**The Choices:** Auto (default), Enabled, Disabled.

#### **PCI-E Compliancy Mode**

This item allows you to select the PCI-E Compliancy Mode.

**The Choices:** v1.0a (default), v1.0.

## 5 Integrated Peripherals

■ Figure 5. Integrated Peripherals

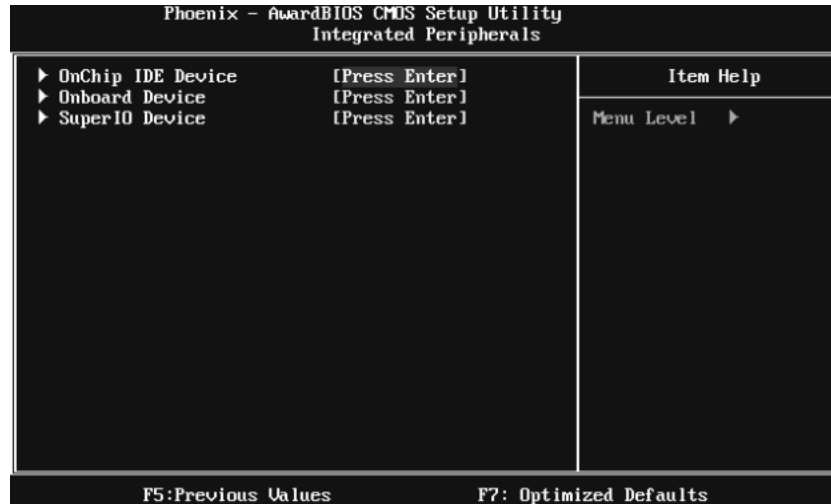

### OnChip IDE Device

If you highlight the literal “Press Enter” next to the “OnChip IDE Device” label and then press the enterkey, it will take you a submenu with the following options:

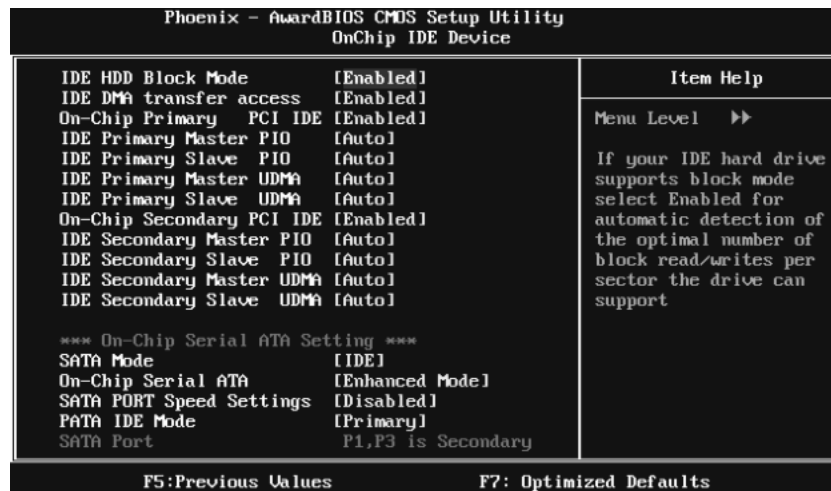

---

## 945GZ Micro 775 SE

---

### IDE HDD Block Mode

Block mode is also called block transfer, multiple commands, or multiple sector read / write. If your IDE hard drive supports block mode (most new drives do), select Enabled for automatic detection of the optimal number of block mode (most new drives do), select Enabled for automatic detection of the optimal number of block read / write per sector where the drive can support.

**The Choices:** Enabled (default), Disabled.

### IDE DMA Transfer Access

This item allows you to enable or disable the IDE transfer access.

**The Choices:** Enabled (default), Disabled.

### On-chip Primary/Secondary PCI IDE

This item allows you to enable or disable the primary/secondary IDE Channel.

**The Choices:** Enabled (default), Disabled.

### IDE Primary/Secondary Master/Slave PIO

The IDE PIO (Programmed Input / Output) fields let you set a PIO mode (0-4) for each of the IDE devices that the onboard IDE interface supports. Modes 0 to 4 will increase performance progressively. In Auto mode, the system automatically determines the best mode for each device.

**The Choices:** Auto (default), Mode0, Mode1, Mode2, Mode3, and Mode4.

### IDE Primary/Secondary Master/Slave UDMA

Ultra DMA/100 functionality can be implemented if it is supported by the IDE hard drives in your system. As well, your operating environment requires a DMA driver (Windows 95 OSR2 or a third party IDE bus master driver). If your hard drive and your system software both support Ultra DMA/100, select Auto to enable BIOS support.

**The Choices:** Auto (default), Disabled.

### SATA Mode

**The Choices:** IDE (default), RAID, AHCI.

### On-Chip Serial ATA

This item allows you to choose:

**Disabled:** disabled SATA Controller

**Combined Mode:** PATA and SATA are combined max of 2 IDE drivers in each channel.

**Enhanced Mode:** enabled both SATA and PATA max of 6 IDE drivers are supported.

**SATA Only:** SATA is operating in legacy mode.

**The Choices:** Disabled, Auto, Combined Mode, **Enhanced Mode** (default), and SATA only.

---

## 945GZ Micro 775 SE

---

### SATA PORT Speed Settings

The Choices: Disabled (default), Force GEN I, Force GEN II.

### PATA IDE Mode

The Choices: Primary (default), Secondary.

### Onboard Device

If you highlight the literal "Press Enter" next to the "Onboard Device" label and then press the enter key, it will take you a submenu with the following options:

Phoenix - AwardBIOS CMOS Setup Utility	
Onboard Device	
USB Controller	[Enabled]
USB 2.0 Controller	[Enabled]
USB Keyboard Support	[Disabled]
USB Mouse Support	[Disabled]
Onboard AC97 Audio	[Auto]
Onboard LAN	[Enabled]
Onboard Lan Boot ROM	[Disabled]
	Item Help
	Menu Level >>

F5: Previous Values      F7: Optimized Defaults

### USB Controller

Select Enabled if your system contains a Universal Serial Bus (USB) controller and you have USB peripherals.

The Choices: Enabled (default), Disabled

### USB 2.0 Controller

This entry is to enable or disable EHCI controller only. This BIOS itself may/ may not have high speed USB support. If the BIOS has high speed USB support built in, the support will automatically turn on, when high speed device were attached.

The Choices: Enabled (default), Disabled.

### USB Keyboard Support

This item allows you to enable or disable the USB Keyboard Legacy Support.

Enabled      Enable USB Keyboard Support.

Disabled (default)      Disable USB Keyboard Support.



## 945GZ Micro 775 SE

---

### USB Mouse Support

This item allows you to enable or disable the USB Mouse Legacy Support.

**Enabled** Enable USB Mouse Support.

**Disabled (default)** Disable USB Mouse Support.

### Onboard AC97 Audio

This item allows you to decide to enable or disable to support AC97 Audio.

**The Choices:** **Auto** (default), Disabled.

### Onboard LAN

This item allows you to enable or disable the Onboard LAN.

**The Choices:** **Enabled** (default), Disabled.

### Onboard LAN Boot ROM

This item allows you to enable or disable the Onboard LAN Boot ROM.

**The Choices:** **Disabled** (default), Enabled.

### Super IO Device

Press Enter to configure the Super I/O Device.

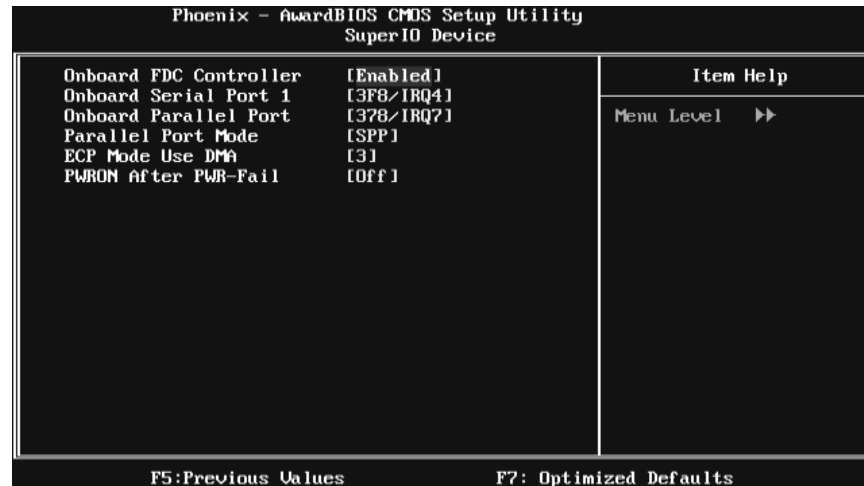

### Onboard FDC Controller

Select Enabled if your system has a floppy disk controller (FDC) installed on the system board and you wish to use it. If install and FDC or the system has no floppy drive, select Disabled in this field.

**The Choices:** **Enabled** (default), Disabled.

### Onboard Serial Port 1

Select an address and corresponding interrupt for the first and second serial ports.

**The Choices:** Disabled, **3F8/IRQ4** (default), 2F8/IRQ3, 3E8/IRQ4, 2E8/IRQ3, Auto.

---

---

## 945GZ Micro 775 SE

---

---

### Onboard Parallel Port

This item allows you to determine access onboard parallel port controller with which I/O Address.

**The Choices:** 378/IRQ 7 (default), 278/IRQ5, 3BC/IRQ7, Disabled.

### Parallel Port Mode

The default value is SPP.

**The Choices:**

SPP (default)	Using Parallel port as Standard Printer Port.
EPP	Using Parallel Port as Enhanced Parallel Port.
ECP	Using Parallel port as Extended Capabilities Port.
ECP+EPP	Using Parallel port as ECP & EPP mode.

### ECP Mode Use DMA

Select a DMA Channel for the port.

**The Choices:** 3 (default), 1.

### PWRON After PWR-Fail

This setting specifies whether your system will reboot after a power fail or interrupts occurs.

Off	Leaves the computer in the power off state.
On	Reboots the computer.
Former-Sts	Restores the system to the status before power failure or interrupt occurs.

**The Choices:** Off (default), On, Former-Sts.

## 6 Power Management Setup

The Power Management Setup Menu allows you to configure your system to utilize energy conservation and power up/power down features.

■ **Figure 6. Power Management Setup**

Phoenix - AwardBIOS CMOS Setup Utility		Item Help
Power Management Setup		Menu Level ▶
▶ ACPI & Wake Up Events	[Press Enter]	
▶ Reload Timer Events	[Press Enter]	
Power Management	[Min Saving]	
Video Off Method	[DPMS]	
Video Off In Suspend	[Yes]	
Suspend Type	[Stop Grant]	
MODEM Use IRQ	[3]	
Suspend Mode	1 Hour	
HDD Power Down	15 Min	
Soft-Off by PWR-BTN	[Instant-Off]	
HPET Support	[Enabled]	
HPET Mode	[32-bit mode]	

F5: Previous Values      F7: Optimized Defaults

### ACPI & Wake Up Events

Phoenix - AwardBIOS CMOS Setup Utility		Item Help
ACPI & Wake Up Events		Menu Level ▶
ACPI Function	[Enabled]	
ACPI Suspend Type	[S1(POS)]	
× Run UGABIOS if S3 Resume	Auto	
Wake-Up by PCI card	[Disabled]	
Power On by Ring	[Disabled]	
× USB KB/MS Wake-Up From S3	Disabled	
Resume by Alarm	[Disabled]	
× Date(of Month) Alarm	0	
× Time(hh:mm:ss) Alarm	0 : 0 : 0	
POWER ON Function	[BUTTON ONLY]	
KB Power ON Password	[Enter]	
Hot Key Power ON	[Ctrl-F1]	

F5: Previous Values      F7: Optimized Defaults

---

## 945GZ Micro 775 SE

---

### ACPI Function

This item displays the status of the Advanced Configuration and Power Management (ACPI).

**The Choices:** Enabled (default), Disabled.

### ACPI Suspend Type

The item allows you to select the suspend type under the ACPI operating system.

**The Choices:** S1 (POS) (default)      Power on Suspend  
S3 (STR)                                  Suspend to RAM  
S1 & S3                                      POS+STR

### Run VGABIOS if S3 Resume

Choosing Enabled will make BIOS run VGA BIOS to initialize the VGA card when system wakes up from S3 state. The system time is shortened if you disable the function, but system will need AGP driver to initialize the card. So, if the AGP driver of the VGA card does not support the initialization feature, the display may work abnormally or not function after S3.

**The Choices:** Auto (default), Yes, No.

### Wake-Up by PCI card

When you select "Enable", a PME signal from PCI card returns the system to Full On state.

**The Choices:** Enabled, Disabled (default).

### Power On by Ring

An input signal on the serial Ring Indicator (RI) line (in other words, an incoming call on the modem) awakens the system from a soft off state.

**The Choices:** Enabled, Disabled (default).

### USB KB/MS Wake-Up From S3

This item allows you to enable or disable USB keyboard wake up from S3.

**The Choices:** Disabled (default), Enabled.

### Resume by Alarm

This function is for setting date and time for your computer to boot up. During Disabled, you cannot use this function. During Enabled, Choose the Date and Time.

#### Date (of Month) Alarm

You can choose which month the system will boot up.

#### Time (hh:mm:ss) Alarm

You can choose what hour, minute and second the system will boot up.

**Note: If you have changed the setting, you must let the system boot up until it goes to the operating system, before this function will work.**

## 945GZ Micro 775 SE

### POWER ON Function

This item allows you to choose the power on function.

**The Choices:** **Button Only** (default), Password, Hot Key, Mouse Move/Click, Mouse Double Click, Any Key, Keyboard 98.

### KB POWER ON Password

Input password and press Enter to set the Keyboard power on password.

### Hot Key Power ON

Input password and press Enter to set the Keyboard power on password.

**The Choices:** **Ctrl-F1** (default), Ctrl-F2, Ctrl-F3, Ctrl-F4, Ctrl-F5, Ctrl-F6, Ctrl-F7, Ctrl-F8, Ctrl-F9, Ctrl-F10, Ctrl-F11, and Ctrl-F12.

### Reload Timer Events

Phoenix - AwardBIOS CMOS Setup Utility		
Reload Timer Events		
Primary IDE 0	[Disabled]	Item Help
Primary IDE 1	[Disabled]	
Secondary IDE 0	[Disabled]	Menu Level >>
Secondary IDE 1	[Disabled]	
FDD, COM, LPT Port	[Disabled]	
PCI PIRQ[A-D]#	[Disabled]	

F5: Previous Values      F7: Optimized Defaults

#### Primary/Secondary IDE 0/1

You can select to enable or disable Primary or Secondary RAID 0 or RAID 1 function under this item.

**The Choices:** **Disabled** (default), Enabled.

#### FDD, COM, LPT Port

You can select to enable or disable FDD, COM, and LPT port under this item.

**The Choices:** **Disabled** (default), Enabled.

#### PCI PIRQ [A-D]#

You can select to enable or disable PCI PIRQ [A-D]# under this item.

**The Choices:** **Disabled** (default), Enabled.

---

## 945GZ Micro 775 SE

---

### **Power Management**

This category allows you to select the type (or degree) of power saving and is directly related to the following modes:

1. HDD Power Down.
2. Suspend Mode.

There are four options of Power Management, three of which have fixed mode settings

#### **Min Saving** (default)

Minimum power management.

Suspend Mode = 1 hr.

HDD Power Down = 15 min

#### **Max. Saving**

Maximum power management only available for SL CPU's.

Suspend Mode = 1 min.

HDD Power Down = 1 min.

#### **User Define**

Allows you to set each mode individually.

When not disabled, each of the ranges is from 1 min. to 1 hr. Except for HDD Power Down which ranges from 1 min. to 15 min. and disable.

### **Video Off Method**

This option determines the manner in which the monitor is goes blank.

**The Choices:** DPMS (default), Blank Screen, V/H SYNC+Blank.

### **Video Off In Suspend**

This determines the manner in which the monitor is blanked.

**The Choices:** Yes (default), No.

### **Suspend Type**

Select the Suspend Type.

**The Choices:** Stop Grant (default), PwrOn Suspend.

### **Modem Use IRQ**

This determines the IRQ, which can be applied in MODEM use.

**The Choices:** 3 (default), 4 / 5 / 7 / 9 / 10 / 11 / NA.

---

## 945GZ Micro 775 SE

---

### Suspend Mode

The item allows you to select the suspend type under ACPI operating system.

**The Choices:** Disabled, 1 Min, 2 Min, 4 Min, 6 Min, 8 Min, 10 Min, 20 Min, 30 Min, 40 Min, **1 Hour** (default).

This selection will cause the system to turn off the vertical and horizontal synchronization ports and write blanks to the video buffer.

Blank Screen

This option only writes blanks to the video buffer.

### HDD Power Down

When enabled, the hard disk drive will power down and after a set time of system inactivity. All other devices remain active.

**The Choices:** Disabled, 1 Min, 2 Min, 3 Min, 4 Min, 5 Min, 6 Min, 7 Min, 8 Min, 9 Min, 10 Min, 11 Min, 12 Min, 13 Min, 14 Min, **15 Min** (default).

### Soft-Off by PWR-BTN

Pressing the power button for more than 4 seconds forces the system to enter the Soft-Off state when the system has "hung."

**The Choices:** Delay 4 Sec, **Instant-Off** (default).

### HPET Support

This item allows you to enable or disable HPET.

**The Choices:** **Enabled** (default), Disabled.

### HPET Mode

This item allows you to select the HPET mode.

**The Choices:** **32-bit mode** (default), 64-bit mode.

### 7 PnP/PCI Configurations

This section describes configuring the PCI bus system. PCI, or Personal Computer Interconnect, is a system which allows I/O devices to operate at speeds nearing the speed of the CPU itself uses when communicating with its own special components. This section covers some very technical items and it is strongly recommended that only experienced users should make any changes to the default settings.

■ **Figure 7. PnP/PCI Configurations**

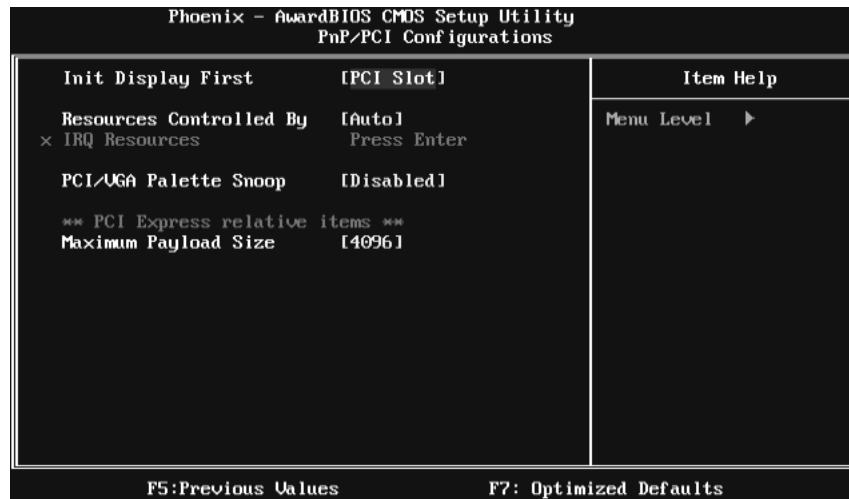

**Init Display First**

This item allows you to decide to activate whether PCI Slot or on-chip VGA first.  
**The Choices:** PCI Slot (default), PCIEx, Onboard.

**Resources Controlled By**

By Choosing “**Auto (ESCD)**” (default), the system BIOS will detect the system resources and automatically assign the relative IRQ and DMA channel for each peripheral. By Choosing “Manual”, the user will need to assign IRQ & DMA for add-on cards. Be sure that there are no IRQ/DMA and I/O port conflicts.  
**The Choices:** Auto (default), Manual.



---

## 945GZ Micro 775 SE

---

### IRQ Resources

This submenu will allow you to assign each system interrupt a type, depending on the type of device using the interrupt. When you press the “Press Enter” tag, you will be directed to a submenu that will allow you to configure the system interrupts. This is only configurable when “Resources Controlled By” is set to “Manual”.

IRQ-3	assigned to	PCI Device
IRQ-4	assigned to	PCI Device
IRQ-5	assigned to	PCI Device
IRQ-7	assigned to	PCI Device
IRQ-9	assigned to	PCI Device
IRQ-10	assigned to	PCI Device
IRQ-11	assigned to	PCI Device
IRQ-12	assigned to	PCI Device
IRQ-14	assigned to	PCI Device
IRQ-15	assigned to	PCI Device

### PCI / VGA Palette Snoop

Choose Disabled or Enabled. Some graphic controllers that are not VGA compatible take the output from a VGA controller and map it to their display as a way to provide boot information and VGA compatibility. However, the color information coming from the VGA controller is drawn from the palette table inside the VGA controller to generate the proper colors, and the graphic controller needs to know what is in the palette of the VGA controller. To do this, the non-VGA graphic controller watches for the Write access to the VGA palette and registers the snoop data. In PCI based systems, where the VGA controller is on the PCI bus and a non-VGA graphic controller is on an ISA bus, the Write Access to the palette will not show up on the ISA bus if the PCI VGA controller responds to the Write.

In this case, the PCI VGA controller should not respond to the Write, it should only snoop the data and permit the access to be forwarded to the ISA bus. The non-VGA ISA graphic controller can then snoop the data on the ISA bus. Unless you have the above situation, you should disable this option.

<b>Disabled</b> (default)	Disable the function.
Enabled	Enable the function.

### Maximum Payload Size

Set the maximum payload size for Transaction packets (TLP).

**The Choice: 4096** (default), 128, 256, 512, 1024, 2048.

### 8 PC Health Status

■ Figure 8. PC Health Status

Phoenix - AwardBIOS CMOS Setup Utility		Item Help
PC Health Status		Menu Level ▶
CPU Fan Control	[Smart]	
CPU Fan Off(°C)	[16]	
CPU Fan Start(°C)	[24]	
CPU Fan Full speed(°C)	[64]	
Start PWM Value	[32]	
Slope PWM	[ 1 PWM value/°C]	
Shutdown Temperature	[Disabled]	
Show H/W Monitor in POST	[Enabled]	
CPU Core		
NB/SB Voltage		
+ 3.3 V		
+ 5.0 V		
12.0 V		
5V(SB)		
Voltage Battery		
Current CPU Temp		
Current CPU FAN Speed		
Current SYS FAN Speed		

F5: Previous Values      F7: Optimized Defaults

#### CPU FAN Control

The Choice “smart” can make your CPU FAN to reduce noise.

**The Choices:** Smart (default), Always On.

#### CPU Fan Off<°C>

If the CPU Temperature is lower than the set value, FAN will turn off.

**The Choices:** Min=0, Max=127, Key in a DEC number.

#### CPU Fan Start<°C>

CPU fan starts to work under smart fan function when arrive this set value.

**The Choices:** Min=0, Max=127, Key in a DEC number.

#### CPU Fan Full speed <°C>

When CPU temperature is reach the set value, the CPU fan will work under Full Speed.

**The Choices:** Min=0, Max=127, Key in a DEC number.

#### Start PWM Value

When CPU temperature arrives to the set value, the CPU fan will work under Smart Fan Function mode. The range is from 0~127, with an interval of 1.

**The Choices:** Min=0, Max=127, Key in a DEC number.

---

## 945GZ Micro 775 SE

---

### Slope PWM

Increasing the value of slope PWM will raise the speed of CPU fan.

**The Choices:** 1 PWM Value/°C (default), 2 PWM Value/°C, 4 PWM Value/°C, 8 PWM Value/°C, 16 PWM Value/°C.

### SHUTDOWN TEMPERATURE

This item allows you to set up the CPU shutdown Temperature. This item only effective under Windows 98 ACPI mode

**The Choices:** 65°C/140°F, 70°C/149°F, 75°C/158°F, **Disabled** (default).

### SHOW H/W MONITOR IN POST

If your computer contains a monitoring system, it will show PC health status during POST stage. The item offers several delay times to select you want.

**The Choices:** Enabled (default), Disabled.

### CPU VCORE, NB/SB VOLTAGE, +3.3V, +5.0V, 12.0V, 5V(SB), VOLTAGE BATTERY

Detect the system's voltage status automatically.

### CURRENT CPU TEMP

This field displays the current temperature of CPU.

### CURRENT CPU FANSPEED

This field displays the current speed of CPU fan.

### CURRENT SYS FANSPEED

This field displays the current speed SYSTEM fan.

## 9 Performance Booster Zone

### ■ Figure 9. Performance Booster Zone

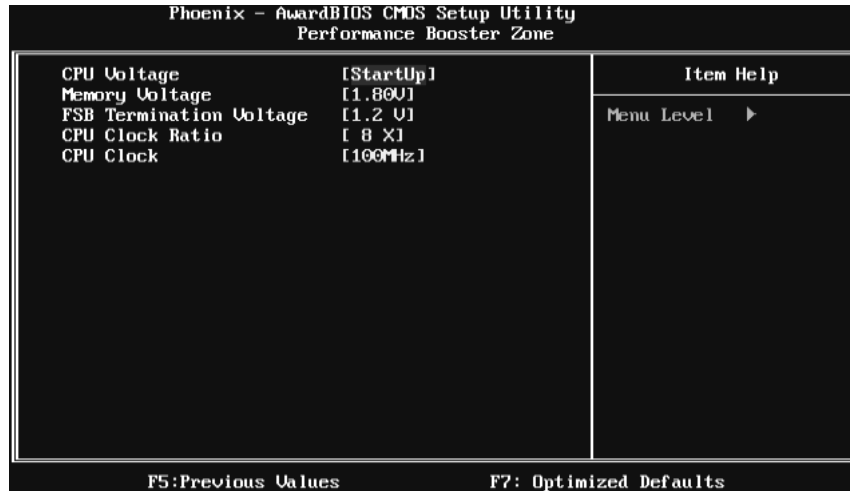

#### CPU Voltage

This item allows you to select CPU Voltage Control.  
The Choices: **StartUp** (default), +0.012V~+0.787V.

#### Memory Voltage

The Choices: **1.80V** (default), 1.90V, 2.00V, 2.10V, 2.20V, 2.30V, 2.40V, 2.50V.

#### FSB Termination Voltage

The Choices: **1.2V** (default), 1.3V, 1.4V, 1.5V.

#### CPU Clock Ratio

This item allows you to select the CPU Ratio.  
Min = 8    Max = 50    Key in a DEC number.  
The Choices: **8X** (default).

#### CPU Clock

This item allows you to select CPU Clock, and CPU over clocking.  
Min = 100    Max = 265    Key in a DEC number.  
The Choices: **100Mhz** (default).

## **945GZ Micro 775 SE**

---

**Special Notice:**

If unfortunately, the system's frequency that you are selected is not functioning, there are two methods of booting-up the system.

**Method 1:**

Clear the COMS data by setting the JCOMS1 ((2-3) closed) as "ON" status. All the CMOS data will be loaded as default setting.

**Method 2:**

Press the <Insert> key and Power button simultaneously, after that keep-on pressing the <Insert> key until the power-on screen showed. This action will boot-up the system according to FSB of the processor.

**It's strongly recommended to set CPU Vcore and dock in default setting. If the CPU Vcore and clock are not in default setting, it may cause CPU or M/B damage.**