

Table of Contents

Table of Contents	1
1.1 Thank-you Note Before You Get Start.....	4
1.2 Features of This Manual	5
1.3 Safety Information	5
Chapter 2 Introduction to This Motherboard	6
2.1 How does your motherboard look like?.....	6
2.2 Specification	7
2.3 Block Diagram	8
Chapter 3 Hardware Installation	9
3.1 Quick Installation Procedure	9
3.2 Installation You Have to Know.....	10
<i>Installing CPU</i>	10
<i>Installing CPU Fan</i>	11
<i>Connecting CPU and System Fans</i>	12
<i>Installing Memory Modules</i>	13
<i>Maximum The Performance of the Dual Channel</i>	14
<i>Connecting IDE and Floppy Cables</i>	15
<i>Connecting Front Panel Cable</i>	16
<i>Connecting ATX Power Cables</i>	17
3.3 Other Installation for Your Reference	18
<i>Setting CPU Voltage and Frequency</i>	18
<i>Connecting Serial ATA</i>	19
<i>Adjusting your Hard Disk Setting</i>	20
<i>Connecting PCI Express x 16 Graphics Slot</i>	22
<i>Connecting PCI Express x 1 Slot</i>	23
<i>Connecting IrDA</i>	24
<i>10/100/1000Mbps LAN Supported</i>	25



<i>Connecting USB2.0</i>	26
<i>Super 7.1 Channel Audio Effect</i>	27
<i>Connecting Front Audio</i>	28
<i>Connecting 1394</i>	29
<i>Connecting COM2 (for i915Ga-EFR11 only)</i>	30
<i>Connecting S/PDIF (Sony/Philips Digital Interface)</i>	31
<i>Connecting Game Port</i>	32
<i>Connecting CD_IN</i>	33
<i>Connecting Case Open</i>	34
<i>Colored Coded Back Panel (for i915Ga-EFR11)</i>	35
<i>Colored Coded Back Panel (for i915Pa-EFR11)</i>	36
<i>LED Indication</i>	37
3.4 Jumper Settings.....	38
Chapter 4 Special Features and Utilities	40
4.1 SATA RAID by ICH6R.....	40
<i>Arouse RAID function in BIOS</i>	40
<i>RAID Configuration Utility</i>	41
4.2 SATA RAID by Promise PDC20579.....	42
<i>RAID Configuration Utility</i>	43
4.3 SilentTek – Noise is Gone!.....	45
4.4 Other Useful Features.....	48
Chapter 5 Setting BIOS	49
<i>Introduction</i>	49
<i>How To Use Phoenix-Award™ BIOS Setup Program</i>	50
<i>How To Enter BIOS Setup</i>	50
<i>BIOS Upgrade under Windows environment</i>	51
<i>WinBIOS Utility</i>	53
<i>Vivid BIOS technology</i>	54

Chapter 6 Installing Drivers 55
6.1 Installing Drivers..... 56
6.2 Installing Utilities 57

Chapter 7 Troubleshooting 58

Chapter 8 Technical Support 59
Model Name and BIOS Version..... 60
Register Your Motherboard 60
Technical Support..... 61

1.1 Thank-you Note Before You Get Start

First of all, we would like to express our gratitude for purchasing AOpen products. Once again, this motherboard is designed uniquely to meet all your personal needs with our great industry-designing ability and our everlasting perseverance to the quality of all our products.

This manual will introduce you how this motherboard is installed. Please keep it well for your future reference. If you lost your printed manual, you may also go to our website at <http://www.aopen.com> to download the updated file.

Now, we would like to invite you to personally experience this user-friendly manual and all of the powerful functions this AOpen product offers.

The logos of Adobe and Acrobat are the registered trademarks of Adobe Systems Incorporated.

The logos of AMD, Athlon, and Duron are the registered trademarks of Advanced Micro Devices, Inc.

The logos of Intel, Intel Celeron, Pentium II, III and Pentium 4 are the registered trademarks of Intel Corporation.

The logos of nVidia are the registered trademarks of nVidia Corporation.

The logos of Microsoft, Windows are the registered trademarks of Microsoft Corporation in America and other countries.

All the titles of the products and the trademarks mentioned in this manual are for the purpose of illustrative conveniences and are possessed by their respective firms.

We regret not informing about any changes in usage standards and other related information. AOpen reserves the right of altering or modifying the content of this manual. In case of any mistakes or incorrect descriptions, which include those on the products, AOpen makes no guarantee or commitments.

This document is based on the copyright laws in order to protect our company and reserve all rights.

Under no circumstances are any types of duplicating and loading this brochure in any databases and media permitted except the permission signed on formal document by AOpen Company.

1996-2004 Copyrights, AOpen Ltd. All rights reserved.

1.2 Features of This Manual

To help you grab the useful information of this motherboard and aware of certain conditions that you might need to know, you will see the icons below frequently:



Note

This contains knowledge you should know in process of assembling, or some helpful tips.



Warning / Caution

Please be careful when you see this mark. It highlights mistakes that occur often during assembling, or something you need to pay attention to.



Tip

This tip tells you some useful information that will make your installation smoothly.

1.3 Safety Information



Please wear a wrist strap and attach it to a metal part of the system unit before handling a component. Alternatively, you can also touch an object that is of ground connection or with metal surface.



Always unplug the power before you make any jumper setting.



Before you install or remove any components on the motherboard, please make sure to disconnect the power first in case of damaging motherboard or other components.

Chapter 2 Introduction to This Motherboard

2.1 How does your motherboard look like?

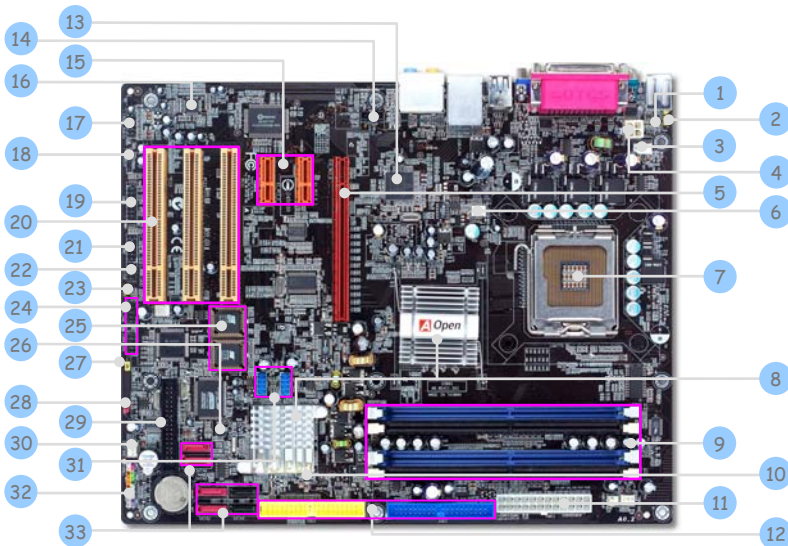

1. Resetable Fuse	18. S/PDIF Connector
2. JP28 PS2 KB/Mouse Wakeup Jumper	19. Game Port Connector
3. CPUFAN Connector	20. 32-bit PCI Expansion Slots x 3
4. 4-pin 12V ATX Power Connector	21. COM2 Connector
5. PCI Express x 16 Graphics Slot	22. IrDA Connector
6. SYSFAN1 Connector	23. JP24 BIOS Rescue Jumper
7. LGA775 CPU Socket supporting Intel CPU FC-LGA4	24. IEEE 1394 Connectors x 2
8. Intel 915G/ICH6R Intel 915P/ICH6R	25. Die-hard BIOS x 2
9. 240-pin DIMMs x 4	26. Case Open Connector
10. BOOT LED	27. JP2 Speaker Output Jumper
11. ATX Power Connector	28. JP14 CMOS Data Clear Jumper
12. IDE Connectors x 2	29. FDD Connector
13. Broadcom Gigabit PCI Express LAN Chip	30. SYSFAN2 Connector
14. CD_IN Connector	31. USB2.0 Connectors x 2
15. PCI Express x 1 slots x 2	32. Front Panel Connector
16. Onboard HD Audio Codec	33. Serial ATA Ports x 6
17. Front Audio Connector	

2.2 Specification

Here is the main function of your motherboard.

Models	i915Ga-EFR11	i915Pa-EFR11
CPU	Intel FC-LGA4 CPU Socket T 800MHz	Intel FC-LGA4 CPU Socket T 800MHz
Chipset	Intel 915G/ICH6R	Intel 915P/ICH6R
Main Memory	Dual Channel Mode DDR DDR2 533 DDR2 DIMM x 4 DIMM Type : 128/256/512MB & 1GB Max Memory : 4GB	Dual Channel Mode DDR DDR2 533 DDR2 DIMM x 4 DIMM Type : 128/256/512MB & 1GB Max Memory : 4GB
Graphics	Integrated VGA Engine in chipset PCI Express x 16 graphics slot, Support ADD2 card	PCI Express x 16 graphics slot,
IDE	Integrated ATA100 and Serial ATA Controller (support RAID 0 and 1) Promise ATA133 and Serial ATA Control Chip(support RAID0,1 and 0+1) Max Disk: 144,000,000GB [by 48 bits LBA Spec.]	Integrated ATA100 and Serial ATA Controller (support RAID 0 and 1) Promise ATA133 and Serial ATA Control Chip(support RAID0,1 and 0+1) Max Disk: 144,000,000GB [by 48 bits LBA Spec.]
LAN	Broadcom Gigabit PCI Express LAN Chip	Broadcom Gigabit PCI Express LAN Chip
Sound	HD Audio Codec on-Board Support Dolby Digital System, 7.1 Channel and above	HD Audio Codec on-Board Support Dolby Digital System, 7.1 Channel and above
USB	Integrated in chipset, USB 2.0 x 8	Integrated in chipset, USB 2.0 x 8
IEEE 1394	TI 1394 Control Chip, IEEE 1394 x 2	TI 1394 Control Chip, IEEE 1394 x 2
Slots	PCI Express x 1 slots x 2 PCI Express x 16 graphics slot x 1 PCI slots x 3	PCI Express x 1 slots x 2 PCI Express x 16 graphics slot x 1 PCI slots x 3
Back Panel I/O	PS/2 Keyboard x 1, PS/2 Mouse x 1 USB Port x 4, LAN Port x 1, VGA Port x 1 COM Port x 1, Printer Port x 1 Speaker_Out x 1, Line_In x 1, MIC_In x 1 Side SUR x 1, Rear SUR x 1 Center/Subwoofer x 1	PS/2 Keyboard x 1, PS/2 Mouse x 1 USB Port x 4, LAN Port x 1 COM Port x 2, Printer Port x 1 Speaker_Out x 1, Line_In x 1, MIC_In x 1 Side SUR x 1, Rear SUR x 1 Center/Subwoofer x 1
On Board Connector	Floppy Drive Connector x 1 IDE Channel: ATA100 x 1, ATA133 x 1 Serial ATA Channel x 6 Front Panel x 1 Front Audio x 1 CPU FAN x 1, System FAN x 1, Chassis FAN x 1 Power FAN x 1 Power Temperature Connector x 1 Game Port Connector x 1 Case Open Connector x 1 S/PDIF Connector x 1 CD_IN x 1, IrDA x 1, COM2 x 1, USB2.0 Connectors x 2 IEEE 1394 x 2	Floppy Drive Connector x 1 IDE Channel: ATA100 x 1, ATA133 x 1 Serial ATA Channel x 6 Front Panel x 1 Front Audio x 1 CPU FAN x 1, System FAN x 1, Chassis FAN x 1 Power FAN x 1 Power Temperature Connector x 1 Game Port Connector x 1 Case Open Connector x 1 S/PDIF Connector x 1 CD_IN x 1, IrDA x 1, USB2.0 Connectors x 2 IEEE 1394 x 2
BIOS	Award PnP 8Mb Flash ROM BIOS x 2	Award PnP 8Mb Flash ROM BIOS x 2
Board Size	305 mm x 244 mm	305 mm x 244 mm

2.3 Block Diagram

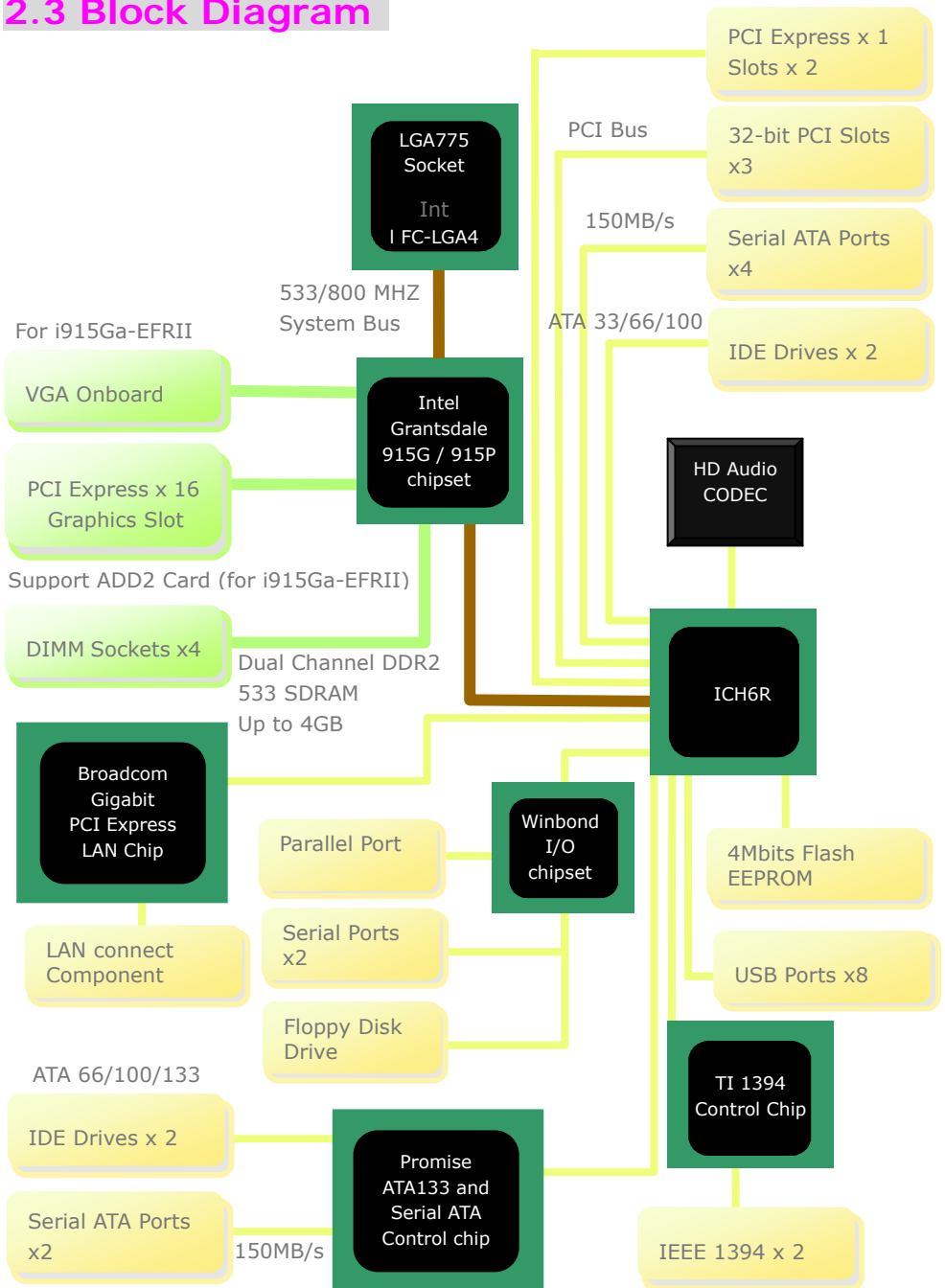

Chapter 3 Hardware Installation

3.1 Quick Installation Procedure

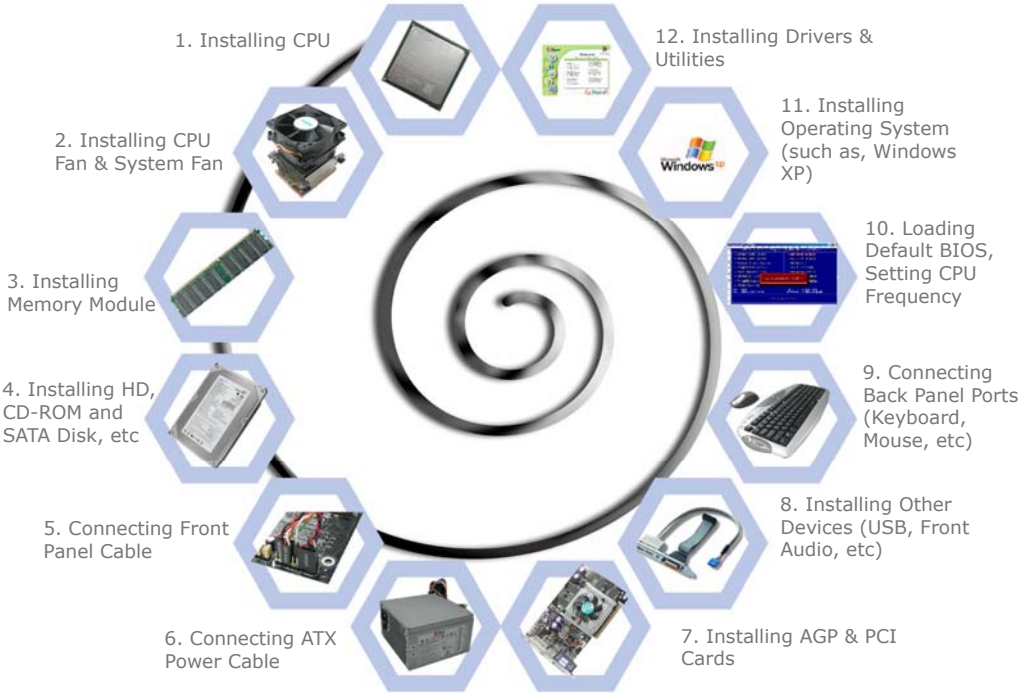

3.2 Installation You Have to Know

Installing CPU

This socket supports FC-LGA4 CPU, which is the latest CPU package developed by Intel. Other forms of CPU package are impossible to be fitted in.

1. Pull CPU socket lever and plate up.
2. Remove plastic cap from CPU socket plate.
3. Locate Pin 1 in the socket and look for a golden arrow on the CPU upper interface. Match Pin 1 and golden arrow. Then insert the CPU into the socket.
4. Press down the CPU socket plate and lever to finish CPU installation.

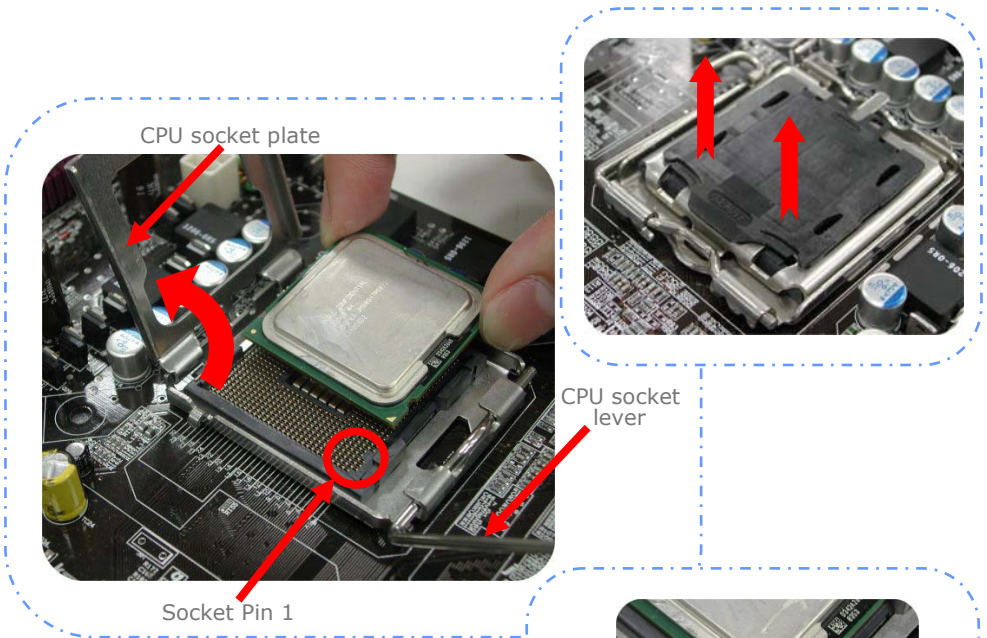

Warning: If you do not match the CPU socket Pin 1 and CPU golden arrow well, you may damage the CPU. And please don't touch CPU socket pins when installing CPU.



Note: It's strongly recommended by Intel to use thermal paste properly to avoid over-heat generated from Prescott CPU.

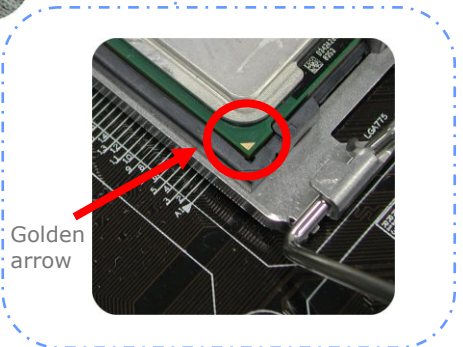



Installing CPU Fan

1. Gently put down the CPU fan on CPU socket with four sticks aiming correctly to the four mounting holes.

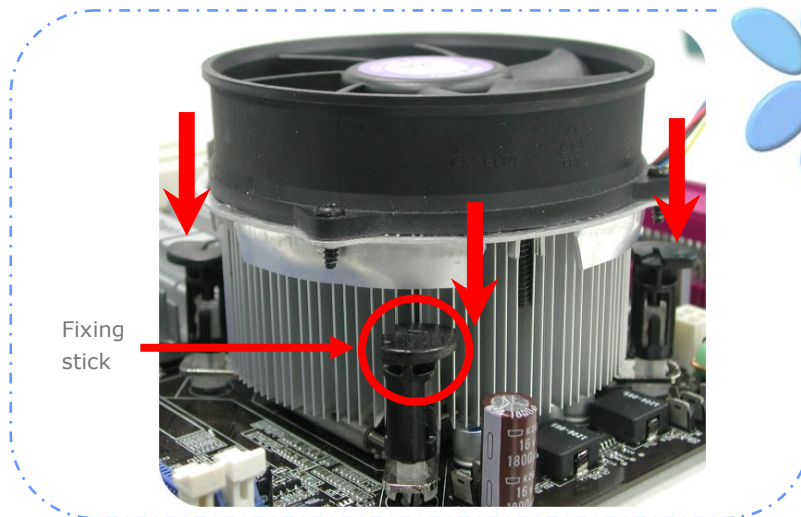

2. Press down four fixing sticks into the holes one by one. Make sure the sticks are firmly fixed into the holes.



 **Note:** The picture above may look different from the product you purchased.

Connecting CPU and System Fans

Plug the CPU fan cable to the 4-pin CPUFAN connector. If you have chassis fan, you can also plug chassis fan in SYSFAN1 or SYSFAN2 connector.

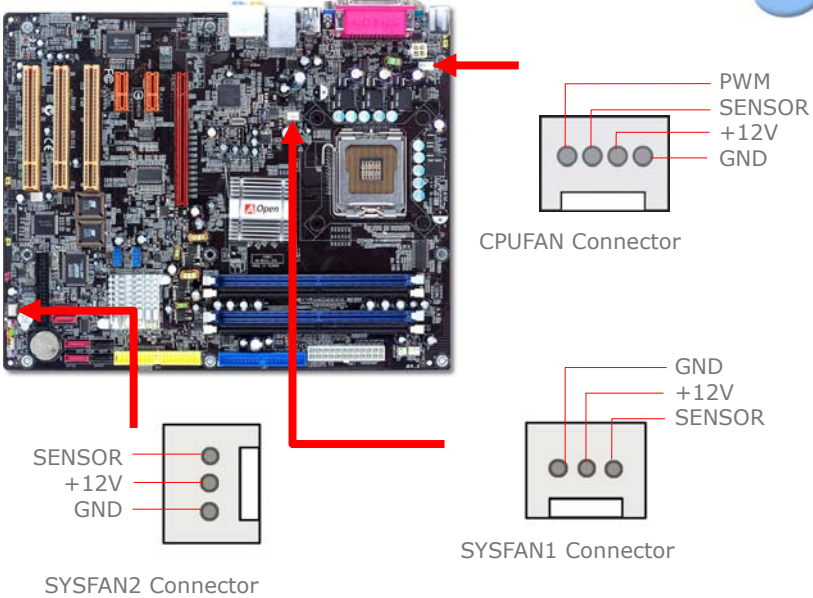

Note: Some CPU fans do not have sensor pin so that they cannot support fan monitoring.

Installing Memory Modules

DIMM slots are designed in black and navy blue which are very easy to recognize. Insert the module straight down to the DIMM slot with both hands and press down firmly until the DIMM module is securely in place.

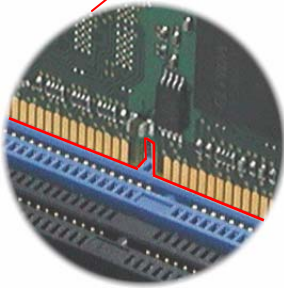
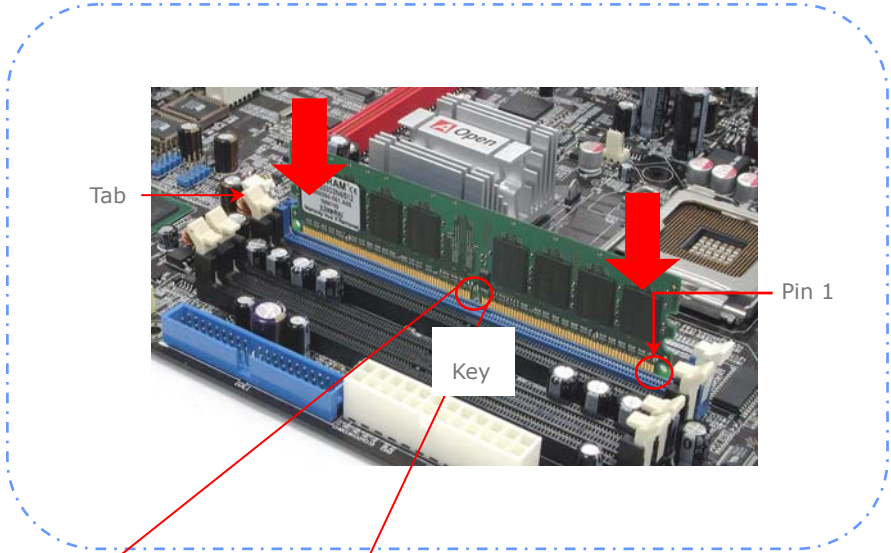

 **Note:** The tabs of the DIMM slot will clip to hold the DIMM in place when the DIMM touches the slot's bottom.

Maximum The Performance of the Dual Channel

To obtain the highest performance of Dual Channel, the configuration of DIMM must meet the following conditions.

Matched DIMM configuration in each channel

- Same density (128MB~1GB)

As long as you insert memory modules of same density into Channel 1 (DIMM A1 & DIMM A2) and Channel 2 (DIMM B1 & DIMM B2), dual channel mode will be enabled.

DIMM A1 + DIMM A2 = DIMM B1 + DIMM B2

Ex: if you insert 1GB memory module into DIMM A1 and DIMM A2, dual channel mode will be enabled when DIMM B1 + DIMM B2 = 1GB

- Same DRAM bus width (x8 or x16)
- Either single-sided or double-sided



Note: Using memory modules of different chip will cause system unstable.

When dual channel mode is successfully enabled, the screen will show "Dual Channel Mode Enabled" while entering POST screen.

```
Phoenix - AwardBIOS v6.00PG, An Energy Star Ally
Copyright (C) 2003, Phoenix Technologies, LTD

Feb.02.2004 AOpen Inc.

Main Processor : Intel Pentium(R) 4 2.80GHz(200x14.0)
Memory Testing : 1048576K OK
CPU Brand Name : Intel(R) Pentium(R) 4 CPU 2.80GHz

Press F10 to load default settings
Press F9 to load previous settings
Press F8 to load user settings
Press F7 to load optimized settings
Press F6 to load user settings
Press F5 to load user settings
Press F4 to load user settings
Press F3 to load user settings
Press F2 to load user settings
Press F1 to load user settings
Press DEL to enter SETUP
Press ESC to exit

Dual Channel Mode Enabled

CPU      200MHz / 200MHz      Default / Setting
DRAM     400MHz / 400MHz      AUTO / AUTO
AGP      66.67MHz / 66.67MHz   1.50 V / 1.50 V
PCI      33.33MHz / 33.33MHz   3.30 V / 3.30 V
IDE Channel 0 Master : WDC WD300AB-00CDB0 22.04A22
IDE Channel 0 Slave : None
IDE Channel 1 Master : None
IDE Channel 1 Slave : None
```



<http://www.aopen.com.tw>

Press DEL to enter SETUP
02/02/2004-Springdale-G-6A79AAB9C-00

Connecting IDE and Floppy Cables

Connect the 34-pin floppy cable and 40-pin, 80-wire IDE cable to floppy connector and IDE connector. Be careful of the pin1 orientation. Wrong orientation may cause system damage.

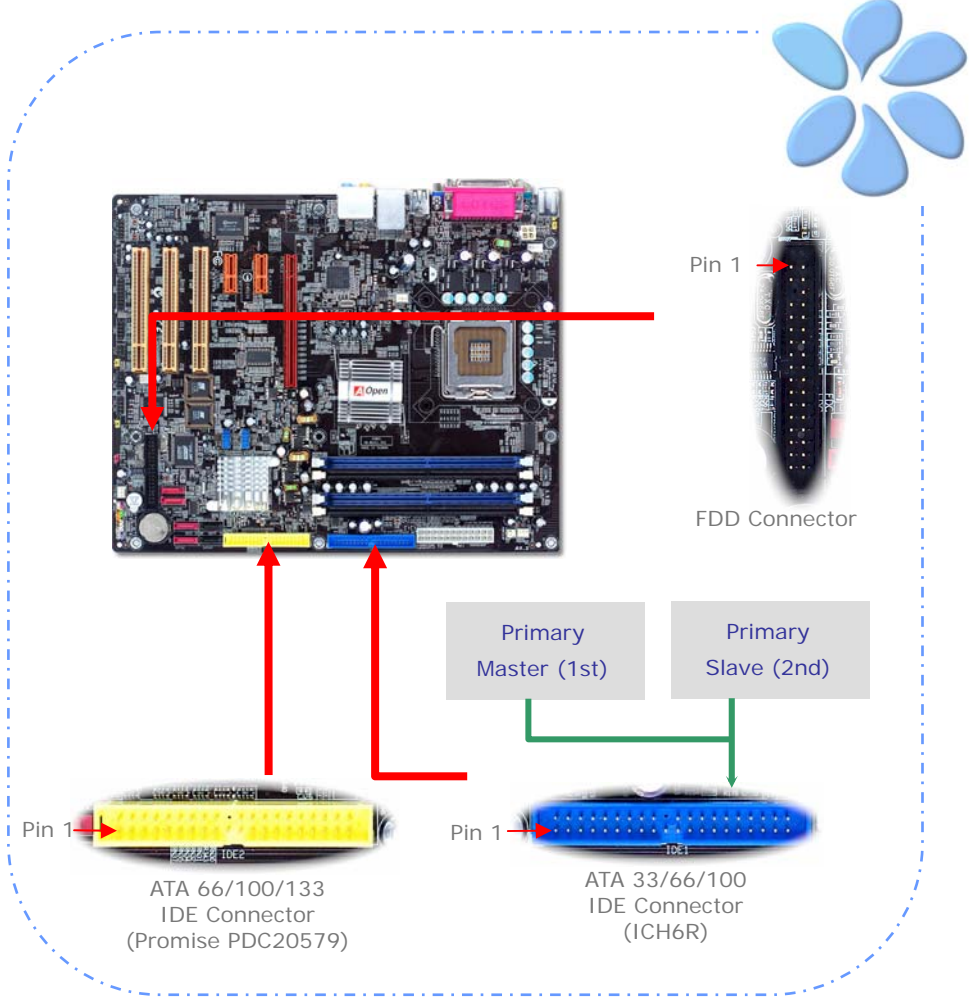

Connecting Front Panel Cable

Attach the power LED, speaker and reset switch connectors to the corresponding pins. If you enable "Suspend Mode" item in BIOS Setup, the ACPI & Power LED will keep flashing while the system is in suspend mode.

Locate the power switch cable from your ATX housing, which is a 2-pin female connector from the housing front panel. Plug this connector to the soft-power switch connector marked SPWR.

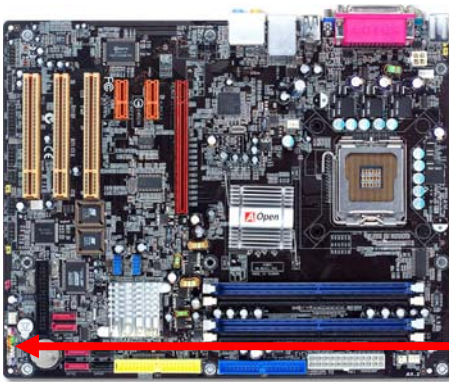

1	
NC	Power Switch
NC	GND
+5V	Power LED-
HDD LED	GND
HDD LED	Power LED+
+5V	NC
+5V	GND
GND	GND
NC	RESET
SPEAKER	GND

Front Panel Connector

Connecting ATX Power Cables

This motherboard comes with a 24-pin ATX power connector and 4-pin 12V ATX power connector as shown below. Make sure you plug them in the right direction. We strongly recommend you to insert the 4-pin connector before connecting the 24-pin connector.

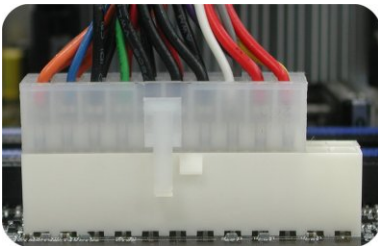
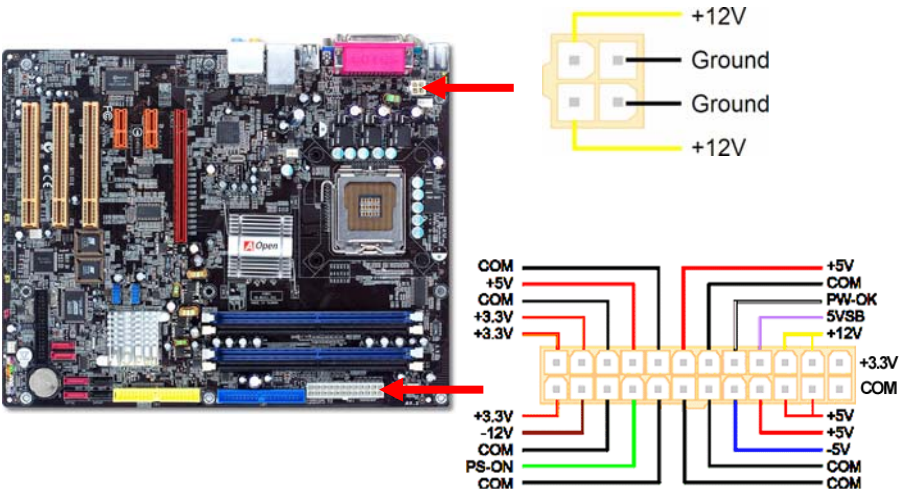

Note: If you don't have 24-pin ATX power cable, please plug your 20-pin ATX power cable leftwards into the ATX power connector as shown leftwards.

3.3 Other Installation for Your Reference

Setting CPU Voltage and Frequency

Setting CPU Core Voltage

This motherboard supports Voltage ID (VID) function to detect CPU voltage automatically during power-on and the range is from 0.8375V to 1.6V. It's not necessary to set CPU core voltage.

Setting CPU Frequency

This motherboard is CPU jumper-less design; you can set CPU frequency by 1MHz stepping CPU Overclocking in the BIOS. **CPU Core Frequency = CPU FSB clock x CPU Ratio**. However, all CPU now sold in market belong to "Fixed Multiplier". That means users can not adjust the CPU Ratio but change CPU FSB clock to achieve overclocking only.

BIOS Setup > Frequency / Voltage Control > CPU Speed Setup

(Users will do the overclocking at their own risks!!)

CPU Ratio	8x, 10x... 24x, 25x, 26x, 27x, 28x
CPU FSB (Adjustment manually)	FSB = 100MHz-400MHz by 1MHz Stepping CPU Overclocking

Processor Number	Processor Frequency	FSB	CPU Ratio	Cache
5 Series				
580	4.00G	800MHZ	20x	1MB L2
570	3.80G	800MHZ	19x	1MB L2
560	3.60G	800MHZ	18x	1MB L2
550	3.40G	800MHZ	17x	1MB L2
540	3.20G	800MHZ	16x	1MB L2
530	3.00G	800MHZ	15x	1MB L2
520	2.80G	800MHZ	14x	1MB L2
3 Series				
350	3.20G	533MHZ	24x	256K L2
345	3.06G	533MHZ	23x	256K L2
340	2.93G	533MHZ	22x	256K L2
335	2.80G	533MHZ	21x	256K L2



Note:
Some CPU fans do not have sensor pin so that they cannot support fan monitoring.

Note: With CPU speed changing rapidly, there might be faster CPU on the market by the time you received this installation guide. This table is kindly for your references only.



Warning: Intel Grantsdale 915G / Grantsdale 915P chipset support maximum 800MHz (200MHz*4) system; higher clock setting may cause serious system damage.



Connecting Serial ATA

To connect a serial ATA disk, you have to have a 7-pin serial ATA cable. Connect two ends of the serial ATA cable to the serial ATA header on the motherboard and the disk. Like every other traditional disk, you also have to connect a power cable. Please be noted that it is a jumper free implement; you don't need to set jumpers to define a master or slave disk. When serial ATA hard disks are installed on serial ATA ports, the one connected on SATA1 will be set as the first boot device automatically. **Please note that it doesn't support Hot-Plug function.**



SATA5
(Promise PDC20579)

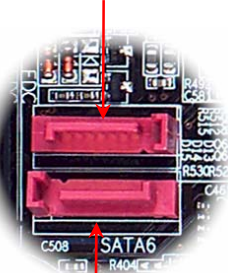

SATA6
(Promise PDC20579)



SATA1
(ICH6R)

SATA2
(ICH6R)



SATA3
(ICH6R)

SATA4
(ICH6R)



Adjusting your Hard Disk Setting

Except its original 1 set of parallel IDE, this motherboard supports the latest serial ATA hard disk. If you are unable to find your newly installed serial ATA hard disks on your operating system after having them installed, the problem may lie in the BIOS setting. You can simply adjust BIOS settings to have them work properly.

After installing your hard disks properly, you can directly go to BIOS setting screen for adjustment. Simply pressing **"Integrated Peripherals → OnChip IDE Device → On-Chip Serial ATA"** to choose your preferable mode. If you have no intention of changing its original setting, the default would be Auto.

Phoenix - AwardBIOS CMOS Setup Utility

- ▶ Standard CMOS Features
- ▶ Advanced BIOS Features
- ▶ Advanced Chipset Features
- ▶ **Integrated Peripherals**
- ▶ Power
- ▶ PnP/PS/2
- ▶ Siler
- ▶ Frequ

Load Setup Defaults
Load Turbo Defaults
Set Password
Save & Exit Setup

Phoenix - AwardBIOS CMOS Setup Utility
Integrated Peripherals

- ▶ OnChip IDE Device
- ▶ SuperIO Device
- ▶ USB Controller
- ▶ USB 2.0 Controller
- ▶ USB Keyboard Support
- ▶ Onboard Audio Codec
- ▶ Onboard LAN Control

Press Enter
Press Enter
Enabled
Enabled
Auto
Enabled
Enabled

Item Help
Menu Level ▶

Phoenix - AwardBIOS CMOS Setup Utility
OnChip IDE Device

- IDE HDD Block Mode Enabled
- On-Chip Primary PCI IDE Enabled
- IDE Primary Master PIO Auto
- IDE Primary Slave PIO Auto
- IDE Primary Master UDMA Auto
- IDE Primary Slave UDMA Auto
- On-Chip Secondary PCI IDE Enabled
- IDE Secondary Master PIO Auto
- IDE Secondary Slave PIO Auto
- IDE Secondary Master UDMA Auto
- IDE Secondary Slave UDMA Auto

Item Help
Menu Level ▶▶

[Disabled]: Disabled SATA Controller.
[Auto]: Auto arrange by BIOS.
[Combined Model]: PATA and SATA are combined ; Max.of 2 IDE drives in each channel.
[Enhanced Model]: Enable both SATA and PATA. Max.of 6 IDE drives are supported.
[SATA Only]: SATA is operating in legacy mode.

*** On-Chip Serial ATA Setting ***
On-Chip Serial ATA Auto

x PATA IDE Mode Primary
SATA Port SATA3,SATA4 Secondary

↑↓←→: Move Enter: Select +/-/PU/PD: Value F10: Save ESC: Exit F1: General Help
F2: Item Help F5: Previous Values F6: Setup Defaults F7: Turbo Defaults

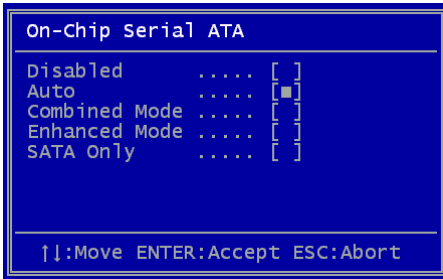

If you desire to change the default setting, press Enter for selection list:

Disabled: You can choose this item if there are only traditional IDE hard disks had been installed on your system. Disabling this item will also cancel the detection of serial ATA hard disks during POST, which will theoretically speed up your boot-up time a little bit; however,

please remember to re-adjust the setting here if you want to use serial ATA hard disk later.

Auto: This is factory default setting on this motherboard. Basically, if your system functions properly, there is no necessary to change it. The system will automatically recognize PATA (IDE) as primary.

Combined Mode: If you have traditional IDE hard disks and serial ATA hard disks installed at the same time, then you can choose this mode. Under this mode, you can randomly choose either IDE hard disks or serial ATA had disk as your first boot device. But please note, IDE will exist with serial ATA in a mapping way, which means it will occupy one of the serial Channel and leave you one serial Channel only. When PATA Mode is set to primary, SATA3 and SATA4 will be set to secondary, and when PATA Mode is set to secondary, SATA1 and SATA2 will be set to primary.

Enhanced Mode: If you are using the latest operating system (say, Windows XP, Windows.NET Server), it is highly recommended that you select Enhanced Mode. Under this mode the system will detect all six devices (traditional IDE x 2, Serial ATA x 4) completely and function perfectly. But please note that PATA Mode is set to primary under this mode.

Note: *According to practical lab tests of us, there are no obvious problems or mistakes happened when we set this mode under Windows2000 operating system; however, it is not recommended by Intel.*

SATA Only: You may select this mode if you install serial ATA hard disks only.

Connecting PCI Express x 16 Graphics Slot

i915Ga-EFR11 / i915Pa-EFR11 provides a PCI Express x 16 Graphics slot, a red slot having the latest PCI Express x 16 specification on motherboard. The PCI Express x 16 is a bus interface targeted for high-performance 3D graphic. Traditionally AGP used both rising and falling edge of the 66MHz clock for 8X AGP, and the data transfer rate could achieve 2.1GB/s. Now PCI Express x 16 is moving to higher data transfer rate, which is upgraded to 8.0GB/s (250MB/s x 16 x 2, it's 4.0GB/s per direction). For i915Ga-EFR11, the PCI Express x 16 graphics slot can automatically recognize a PCI Express x 16 Graphics card or a Multiplexed Intel DVO Output card depending on which cards being inserted, such as PCI Express x 16 Graphics, or ADD2 (AGP Digital Display 2) cards. With an ADD2 card implemented to this slot, Multiplexed Intel DVO output will provide high-speed digital connection for digital displays or TV-OUT functionality.

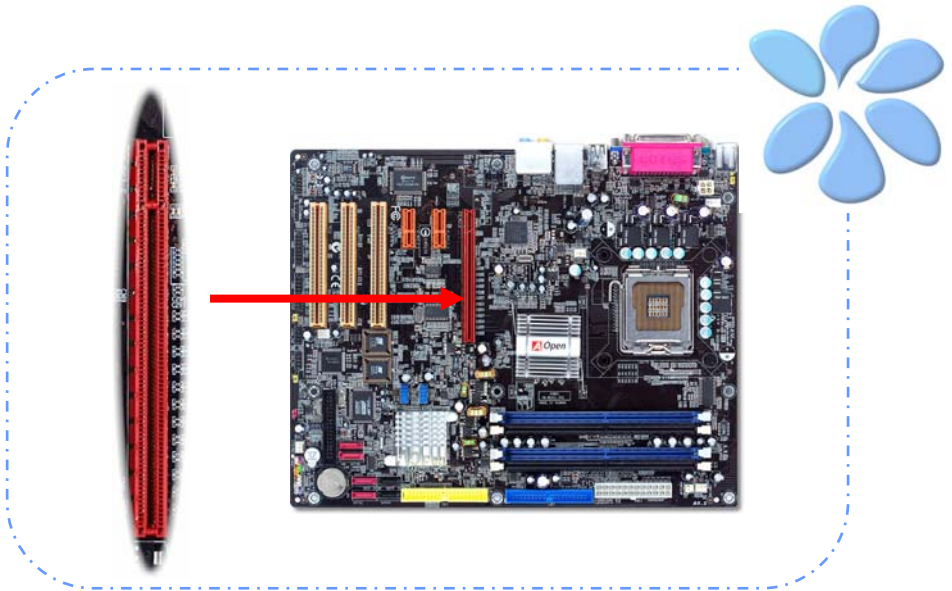

Connecting PCI Express x 1 Slot

This motherboard provides one PCI Express x 1 slot, which is located between the PCI Express x 16 and traditional PCI slot. In order to go with the step of today's and tomorrow's processors, PCI Express x 1 provides higher I/O bandwidth. The transfer data rate could achieve 500MB/s concurrently (it's 250MB/s per direction), which is nearly 4 times faster than the traditional PCI. You could install any PCI Express x 1 device in these slots for your preference.

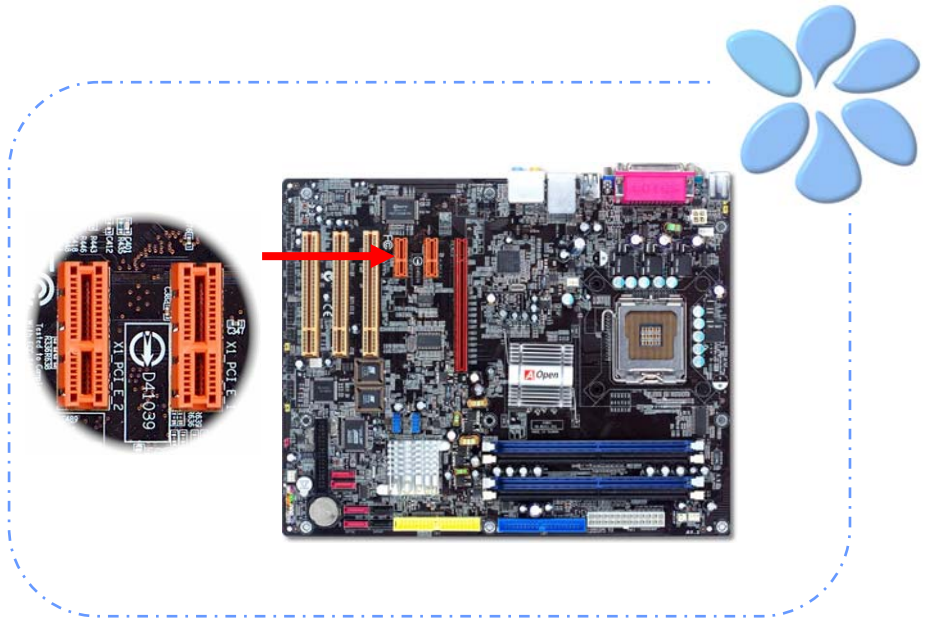

Connecting IrDA

The IrDA connector can be configured to support wireless infrared module, with this module and application software such as Laplink or Windows Direct Cable Connection, user can transfer files to or from laptops, notebooks, PDA devices and printers. This connector supports both HPSIR (115.2Kbps, 2 meters) and ASK-IR (56Kbps).

Install an infrared module onto the IrDA connector and enable the infrared function from BIOS Setup, UART Mode, you can use this function. Please make sure you connect correct orientation when plugging IrDA module.

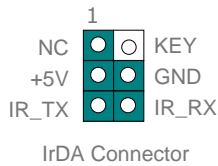
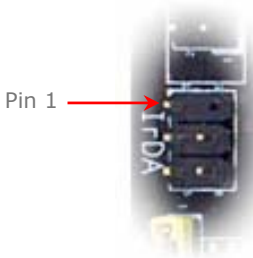

10/100/1000Mbps LAN Supported

On the strength of Broadcom Gigabit LAN controller on board, this motherboard provides 10/100/1000Mbps Ethernet for office and home use. The Ethernet RJ45 connector is located on the top of USB connectors. The right hand side LED indicates link mode; it lights in yellow when linking to network. The left hand side LED indicates the transfer mode and will light in green when data is transferring at 100Mbps (never lights while at 10Mbps), but will light in orange when transferring in Gigabit's mode. To enable or disable this function, you may simply adjust it through BIOS. To enable LAN wakeup function, you have to set the "Wake on PCI Card" enable in the BIOS "Power Management Setup" section.



Speed LED (Left)
Green 100Mbps
Orange Gigabit mode

ACT LED (Right)
Yellow

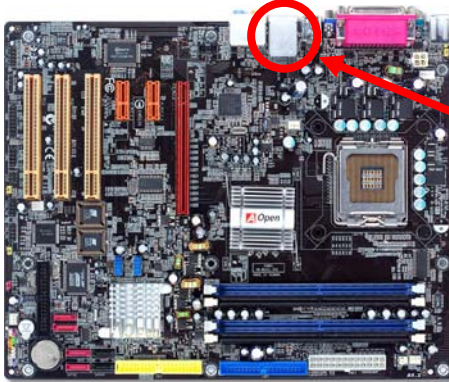

Connecting USB2.0

This motherboard provides eight USB 2.0 ports to connect USB devices such as mouse, keyboard, modem, printer, etc. There are four ports on the back panel. You can use proper cables to connect Front USB connector to USB modules or chassis front panel.

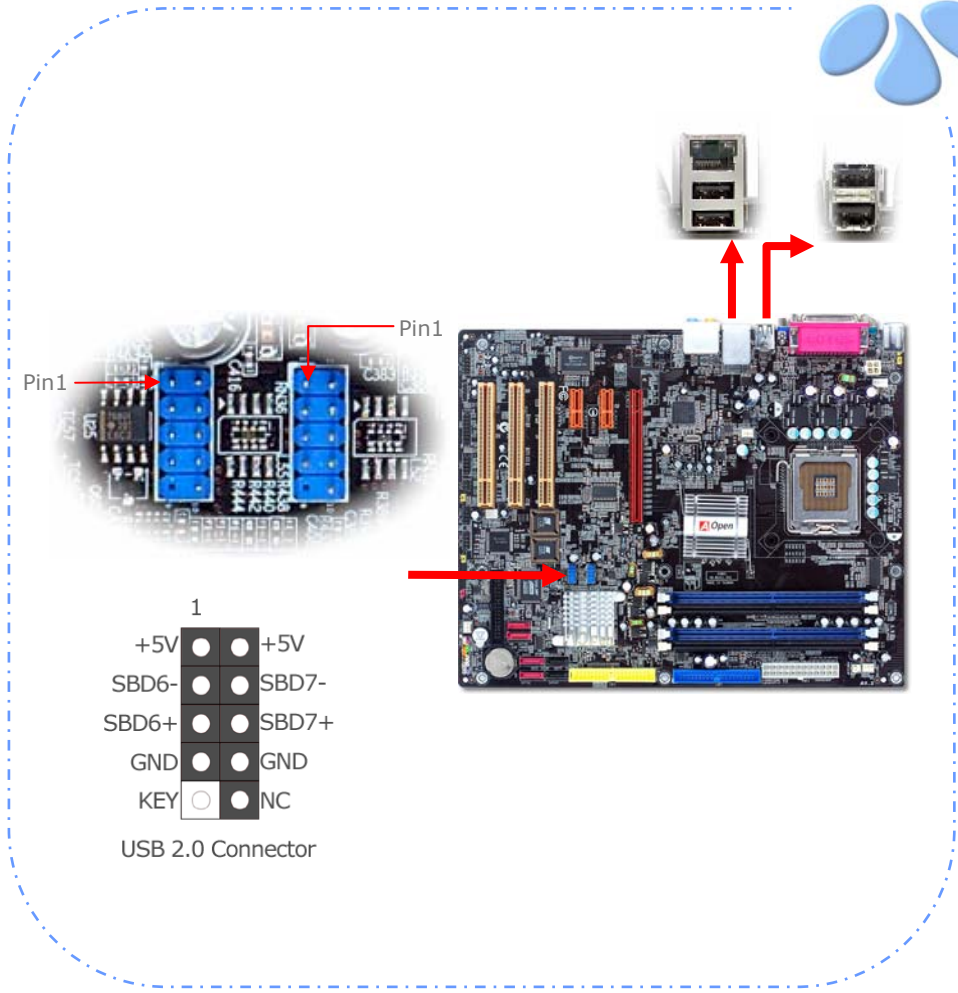

Super 7.1 Channel Audio Effect

This motherboard comes with an ALC880 or ALC850 CODEC, which supports the latest 7.1 Channel with high quality of audio effects, bringing you a brand new audio experience. This motherboard provides 7.1 Channel ports shown as below. Picture represents the standard location of all speakers in 7.1 Channel sound tracks. Please connect the plug of your front speakers to the green "Speaker out" port , rear surround speakers to orange port, side surround speakers to gray port and both of the center and subwoofer speakers to black port on the back panel..

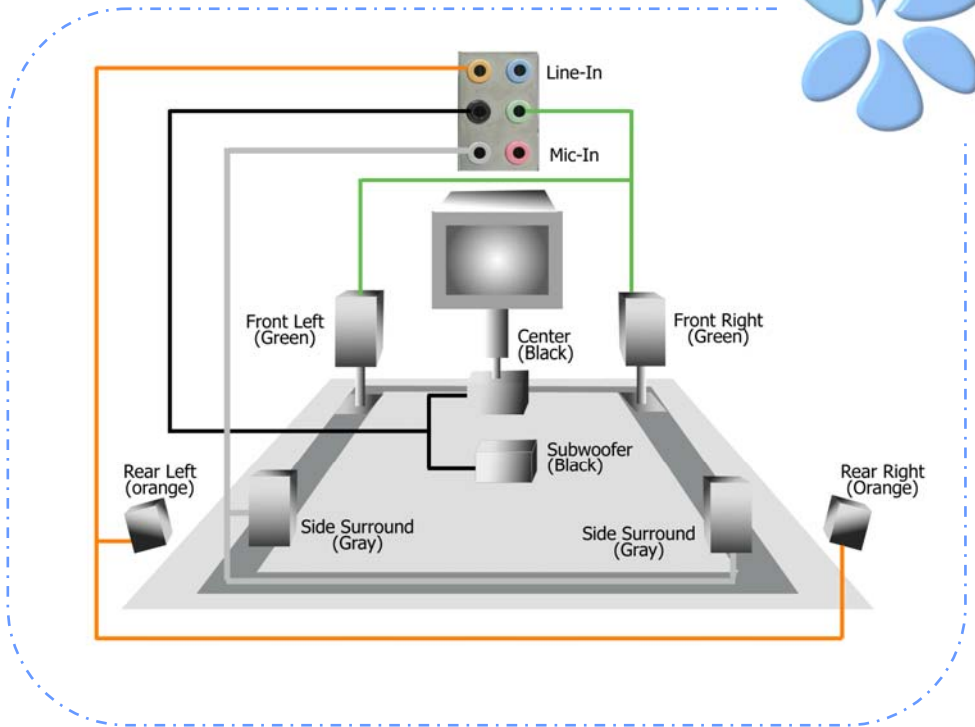

Connecting Front Audio

If the housing is designed with an audio port on the front panel, you'll be able to connect onboard audio to front panel through this connector. **Please be informed that to have front audio ports work properly, the front audio panel of the housing should be designed for High definition Audio jack. If the front audio panel is not designed for High Definition Audio jack, we strongly recommend you to connect the microphone to the back panel of the motherboard.**

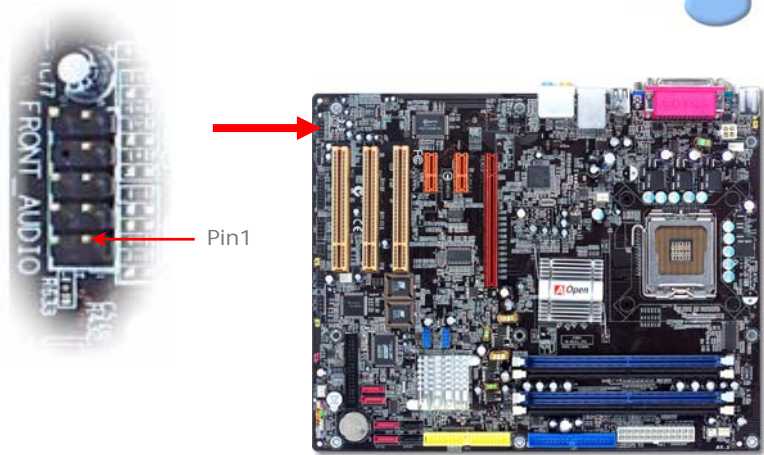

SENSE2_RETURN	●	●	PORT2L
KEY	○	●	SENSE_SEND
SENSE1_RETURN	●	●	PORT2R
PRESENCE#	●	●	PORT1R
GND	●	●	PORT1L
		1	

Connecting 1394

With IEEE1394 Chip on board (TI 1394), having its data transfer rate up to 400Mb/s, this interface can connect to devices that require high data transferring performance such as digital camera, scanner or others IEEE 1394 devices. Please use appropriate cables to connect IEEE1394 devices.

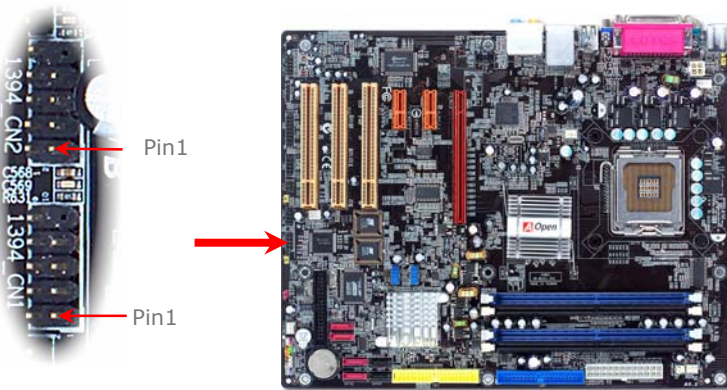

	10	9
SHIED GND	●	○
+12V(Fused)	●	●
TPB-	●	TPB+
GND	●	GND
TPA-	●	TPA+
	2	1
IEEE 1394 Connector		



Warning: Please note that Hot-Plug is not allowed on IEEE 1394 headers; doing so will burn the controller IC and damage the motherboard.

Connecting COM2 (for i915Ga-EFR11 only)

This motherboard provides two serial ports. One of them is on back panel connector, and the other is on the left of board. With proper cable, you can connect it to the back panel of chassis.

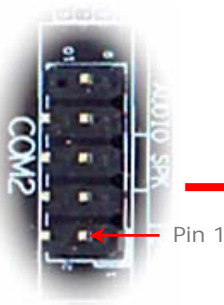

○	●	R1#
CTS#	●	RTS#
DSR#	●	GND
DTR#	●	SOUT
SIN	●	DCD#
	1	

Connecting S/PDIF (Sony/Philips Digital Interface)

S/PDIF (Sony/Philips Digital Interface) is a newest audio transfer file format, which provides impressive audio quality through optical fiber and allows you to enjoy digital audio instead of analog audio. Through a specific audio cable, you can connect the S/PDIF connector to other end of the S/PDIF audio module, which bears S/PDIF digital output. Normally there are two S/PDIF outputs as shown, one for RCA connector, the most common one used for consumer audio products, and the other for optical connector with better audio quality. Same as outputs, you can also connect RCA or optical audio products to input connectors on the module and have the voice or music come out from your computer. However, you must have a S/PDIF supported speaker/amplifier/decoder with S/PDIF digital input/output to connect to the S/PDIF digital input/output to make the most out of this function.

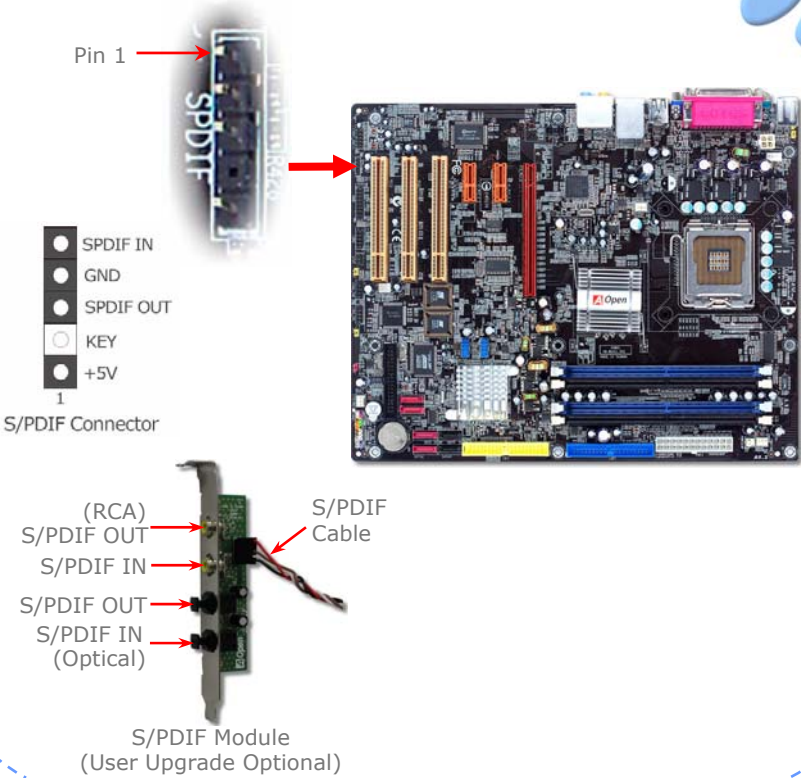

Connecting Game Port

This motherboard comes with a game port (Joystick-Midi) for you to connect any midi devices or joysticks. To use this function you have to have a joystick module and connect it with a game port cable to this port on the motherboard.



Pin1



	1	2	
+5V	●	●	+5V
JAB1	●	●	JBB1
JACX	●	●	JBCX
GND	●	●	MIDI_TXD
GND	●	●	JBCY
JACY	●	●	JBB2
JAB2	●	●	MIDI_RXD
+5V	●	○	KEY
	15	16	

Game Port Connector



(User Upgrade Optional)

Connecting CD_IN

This connector is designed to connect CD Audio cable from CDROM or DVD drive to onboard sound.

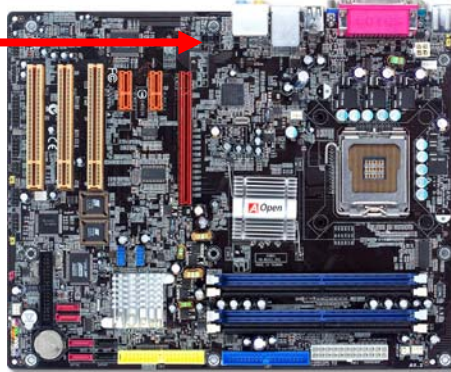
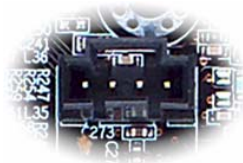

CD-IN Connector

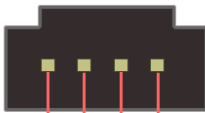

R GND GND L

Connecting Case Open

The "CASE OPEN" header provides chassis intrusion-monitoring function. To make this function work, you have to enable it in the system BIOS, connect this header to a sensor somewhere on the chassis. So, whenever the sensor is triggered by lights or by the opening of the chassis, the system will beep to inform you. Please be informed that this useful function only applies to advanced chassis; you may purchase an extra sensor, attach it on your chassis and make a good use of this function.

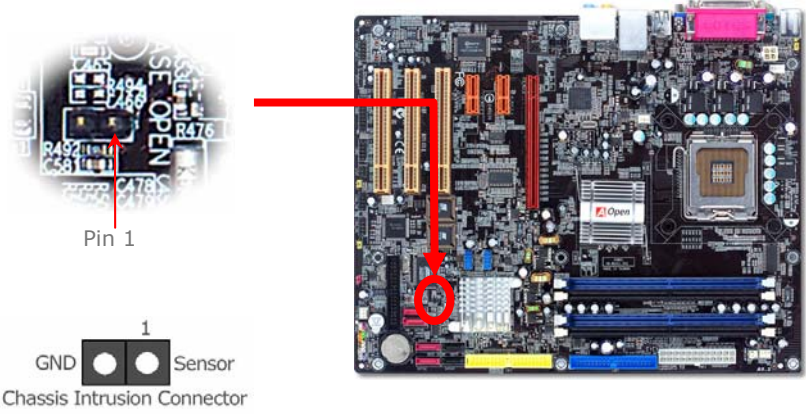

Colored Coded Back Panel (for i915Ga-EFR11)

The onboard I/O devices have PS/2 Keyboard, PS/2 Mouse, RJ-45 LAN Connector, COM1, VGA port, Printer, USB, Azalia sound and game ports. The view angle of drawing shown here is from the back panel of the housing.

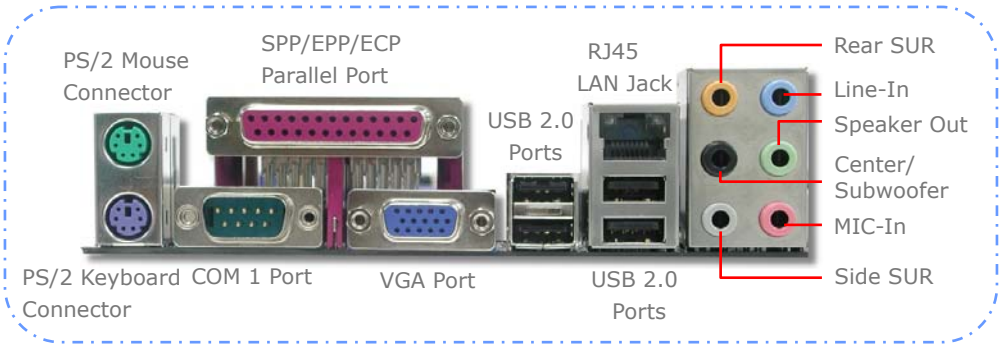

PS/2 Keyboard:

For standard keyboard, which use a PS/2 plug.

PS/2 Mouse:

For PC-Mouse, which use a PS/2 plug.

Parallel Port:

To connect with SPP/ECP/EPP printer.

COM1 Port:

To connect with pointing devices, modem or others serial devices.

VGA Port:

To connect with PC monitor.

RJ-45 LAN Port:

To connect Ethernet for home or office use.

USB Port:

Available for connecting USB devices.

Rear SUR:

For rear surround speaker.

Line-In:

Comes from the signal sources, such as CD/Tape player.

Center/Subwoofer:

For center & subwoofer speaker.

Speaker Out:

To External Speaker, Earphone or Amplifier.

Side SUR:

For side surround speaker.

MIC-In:

For Microphone.

Colored Coded Back Panel (for i915Pa-EFR11)

The onboard I/O devices have PS/2 Keyboard, PS/2 Mouse, RJ-45 LAN Connector, COM1, COM2, Printer, USB, Azalia sound and game ports. The view angle of drawing shown here is from the back panel of the housing.

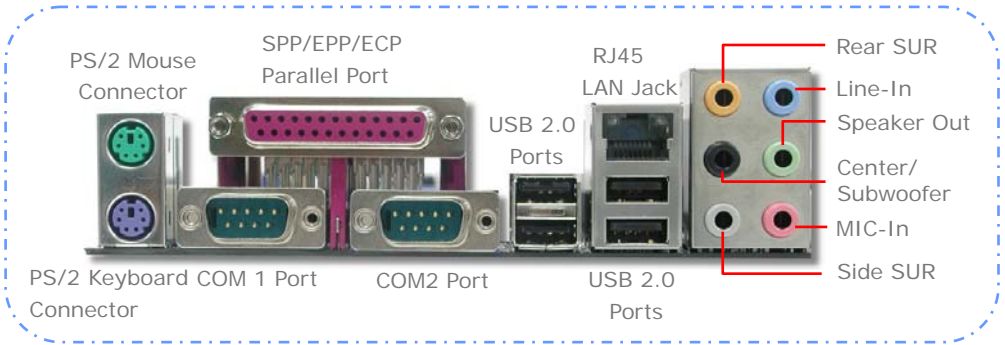

PS/2 Keyboard:

For standard keyboard, which use a PS/2 plug.

PS/2 Mouse:

For PC-Mouse, which use a PS/2 plug.

Parallel Port:

To connect with SPP/ECP/EPP printer.

COM1 Port:

To connect with pointing devices, modem or others serial devices.

COM2 Port:

To connect with pointing devices, modem or others serial devices.

RJ-45 LAN Port:

To connect Ethernet for home or office use.

USB Port:

Available for connecting USB devices.

Rear SUR:

For rear surround speaker.

Line-In:

Comes from the signal sources, such as CD/Tape player.

Center/Subwoofer:

For center & subwoofer speaker.

Speaker Out:

To External Speaker, Earphone or Amplifier.

Side SUR:

For side surround speaker.

MIC-In:

For Microphone.

LED Indication

LED indication including Boot LED and Standby LED are AOpen's considerate designs that aim at providing you friendly system information.

STBY LED will light up when power is provided to the motherboard, giving you a convenient indication check the system power status in circumstances such as power on/off, stand-by mode and RAM power status during Suspend to RAM mode.

BOOT LED will keep blinking when you power the system on and when your system is under POST (Power-On Self Test). After POST diagnoses everything all right and finishes the booting, the LED will stay on otherwise it will remain flashing to warn you that mistakes have occurred during POST

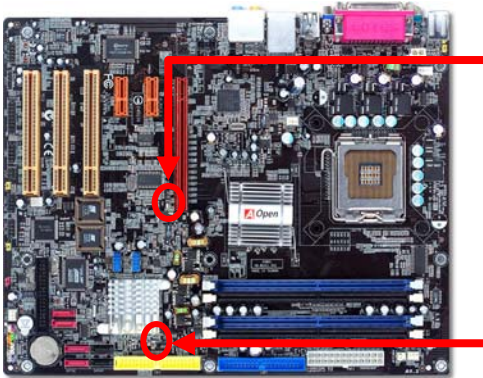

STBY LED



BOOT LED

3.4 Jumper Settings

JP28 Keyboard / Mouse Wakeup Jumper

This motherboard provides PS2 keyboard / mouse wake-up function.



JP28 KB/Mouse Wakeup Jumper

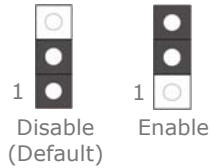

JP2 Speaker Output Jumper

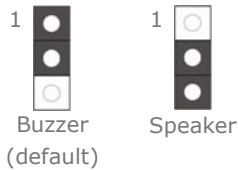

JP2 Speaker Output

Allows you to turn off the voice from buzzer or speaker. You can choose not to be bothered by the warning made from Dr. Voice when it detects any error in operating system.

JP24 BIOS Rescue Jumper

This motherboard provides DieHard BIOS II function to rescue your BIOS and protect BIOS from viruses. Once your BIOS were crashed, please set JP24 to Pin2-3 to boot up the system with BIOS 2. Then set the JP24 back to Pin1-2. You can go to our website (<http://download.aopen.com.tw/downloads>) to download your BIOS version suited for your motherboard, and have it flashed.

Moreover BIOS 2 is further enhanced with data saving function. DieHard BIOS II allows you to turn BIOS2 into a Read-and-write ROM with larger space provided.

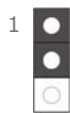

Normal
(default)



Rescue
(Boot from BIOS2)

JP24 BIOS Rescue Jumper

Chapter 4 Special Features and Utilities

4.1 SATA RAID by ICH6R

Arouse RAID function in BIOS

With Intel ICH6R integrated onboard, this motherboard supports RAID 0 and RAID 1 functions. For more RAID introduction, please visit our website:

<http://english.aopen.com.tw/tech/techinside/RAID.htm>

After having properly installed your Serial ATA hard disks, you may directly get into the BIOS setting screen for adjustment. You may simply press "*Integrated Peripherals* → *OnChip IDE Device* → *On-Chip Serial ATA*" to choose Combined Mode. In order to utilize Serial ATA function, please select RAID in SATA Mode. Finally, do save the changes and exit BIOS setup screen.



Warning: The Serial ATA RAID function can be supported under Windows XP and Windows .Net environments.



RAID Configuration Utility

In order to make sure your system can recognize and operate Serial ATA RAID device smoothly, we have to enter RAID Option ROM to do some configuration. After finishing the BIOS setup and reboot, you will see [Press CTRL + I to enter configuration Utility] about half way through the boot up. Please press these two buttons simultaneously. When you enter you will be presented with a screen as shown below:

1. Create RAID Volume

This section allows you to set up a name to identify the RAID volume and to choose the RAID level best suited to your usage mode.

```
Intel(R) Application Accelerator RAID Option ROM v4.0.0.6211
Copyright(C) 2003-04 Intel Corporation. All Rights Reserved.

[ MAIN MENU ]
1. Create RAID Volume
2. Delete RAID Volume
3. Reset Disks to Non-RAID
4. Exit

[ DISK/VOLUME INFORMATION ]

RAID Volumes:
None defined.

Physical Disks:
Port Drive Model Serial # Size Type/Status(Vol ID)
0 WDC WD360GD-00FN WD-WMAH91023400 34.4GB Non-RAID Disk
1 ST380023AS 3KB16H7H 74.5GB Non-RAID Disk
2 WDC WD360GD-00FN WD-WMAH91040501 34.4GB Non-RAID Disk
3 ST380023AS 3KB0USJU 74.5GB Non-RAID Disk

[↑↓]-Select [ESC]-Exit [ENTER]-Select Menu
```

2. Delete RAID Volume

This section allows you to delete a RAID volume. Please be noted that deleting a volume will destroy the volume data on the drive(s) and cause any member disks to become available as non-RAID disks.

```
Intel(R) Application Accelerator RAID Option ROM v4.0.0.6211
Copyright(C) 2003-04 Intel Corporation. All Rights Reserved.

[ MAIN MENU ]
1. Create RAID Volume
2. Delete RAID Volume
3. Reset Disks to Non-RAID
4. Exit

[ DISK/VOLUME INFORMATION ]

RAID Volumes:
ID Name Level Strip Size Status Bootable
0 RAID_Volume0 RAID0(Stripe) 128KB 68.9GB Normal Yes

Physical Disks:
Port Drive Model Serial # Size Type/Status(Vol ID)
0 WDC WD360GD-00FN WD-WMAH91023400 34.4GB Member Disk(0)
1 ST380023AS 3KB16H7H 74.5GB Non-RAID Disk
2 WDC WD360GD-00FN WD-WMAH91040501 34.4GB Member Disk(0)
3 ST380023AS 3KB0USJU 74.5GB Non-RAID Disk

[↑↓]-Select [ESC]-Exit [ENTER]-Select Menu
```

4.2 SATA RAID by Promise PDC20579

Apart from the RAID function offered by Intel ICH6R, this motherboard is also designed with Promise Serial ATA (PDC20579) controller onboard, which is capable of providing you additional RAID 0, 1, 0+1 through 1 ATA133 IDE connector and 2 SATA connectors.

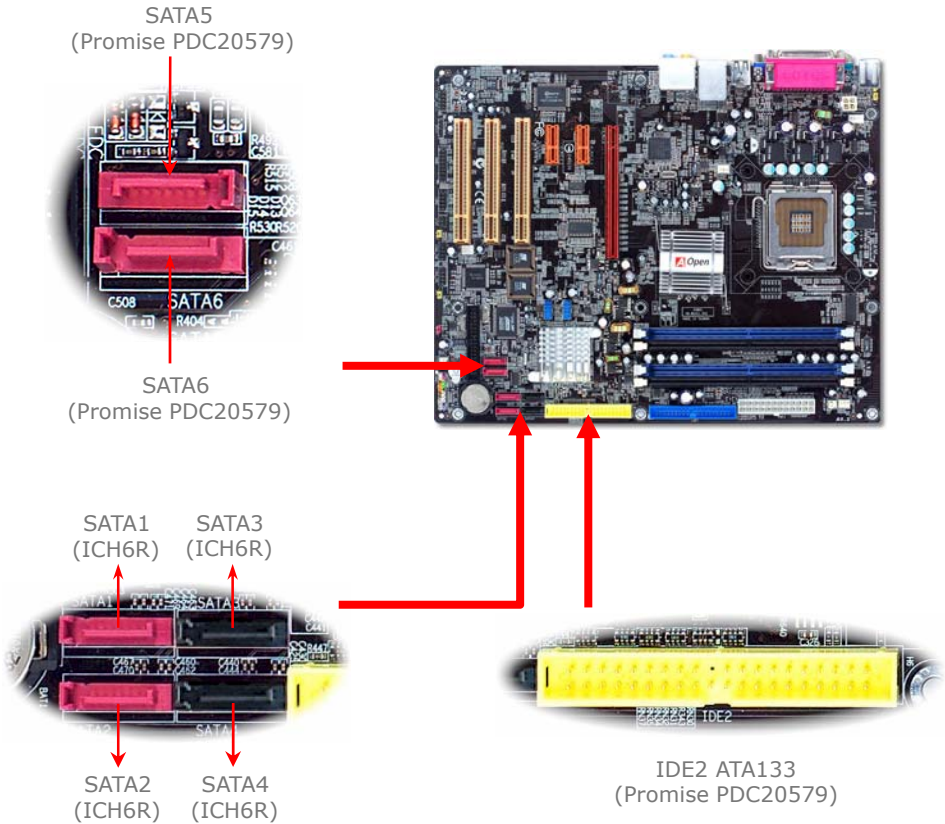

Channel	SATA 1/2/3/4	SATA 5/6 & IDE2
RAID Function	RAID 0, 1	RAID 0, 1, 0+1
Chipset	Intel ICH6R	Promise PDC20579



Note: Please be noted that the "1MHz stepping PCI overclocking" will automatically disabled when SATA device is being connected, for preventing any system instability.

RAID Configuration Utility

Promise PDC20579 is capable of creating RAID 0, 1, 0+1 by SATA5, 6 and IDE2. When driver is successfully installed, please press <Ctrl-F> in POST to enter FastBuild Utility to set up RAID arrays.

The Main Menu of FastBuild Utility

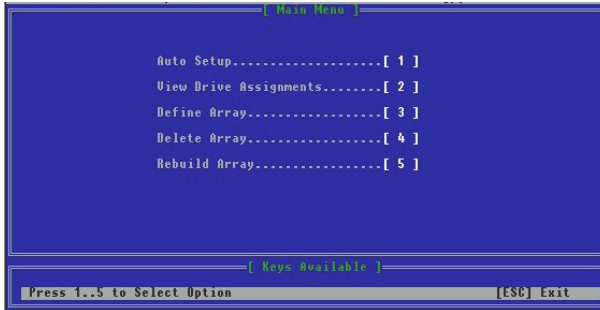

Auto Setup: Press 1 to enter Auto Setup and BIOS will automatically optimize your RAID array depending on your personal demand for data storage.

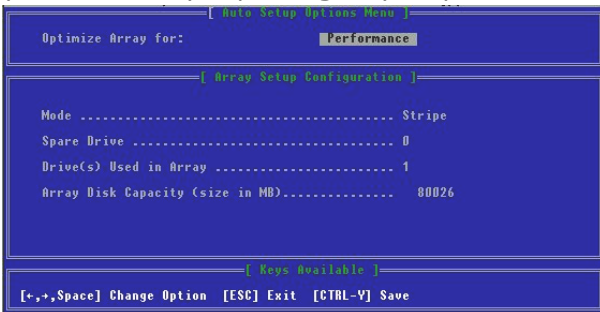

View Drive Assignments: Press 2 to enter View Drive Assignments and BIOS will show you the hard drive information by physical array.

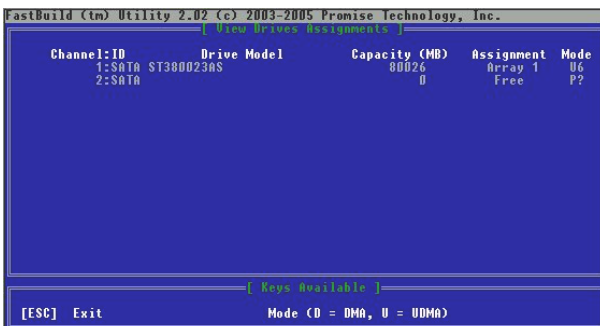

Define Array: Press 3 to enter Define Array and BIOS will allow you to set up a RAID array by choosing Array No, RAID Mode, and Total Drv.



Delete Array: Press 4 to enter Delete Array and BIOS will allow you to delete an existing RAID array.



Rebuild Array: Press 5 to enter Rebuild Array and BIOS will allow you to rebuild a crashed RAID array.



4.3 SilentTek – Noise is Gone!



As CPU clock keeps rocketing higher and higher, it has inevitably brought higher heat and system temperature in a relative way. The way we deal with this heat problem, however, is to spare no effort to add one fan after another to protect our pampered system, expecting these fans cool down our machine as much as they can.

But at the same time, we believe that some users are affected terribly by the irritating noises of these fans while working with their PC. As a matter of fact, we do not have to get our fans running at such a high speed in most cases; on the contrary, we discovered that having your fans running at appropriate time and speed not only reduces the noise, but also consumes the least power the system needs, so as to prevent over-wasting of energy resource.

Today, AOpen Motherboard is honored to bring you a new overall solution, SilentTek, to make your system quiet. To collocate with hardware circuit, BIOS and the utility under Windows, SilentTek combines "Hardware-Status Monitoring", "Overheat Warning" and "Fan Speed Control" in a user-friendly interface to provide you a perfect balance among noises, system performance and stability.

```
Phoenix - AwardBIOS CMOS Setup Utility
SilentTek Control
```

CPUFAN	Boot Speed	70%	2800 RPM
SYSFAN1	Boot Speed	70%	---- RPM
SYSFAN2	Boot Speed	70%	None
PWRFAN	Boot Speed	70%	None
Fan Mode		Full Speed	
x	CPUFAN	Fixed Speed	100% 4000 RPM
x	SYSFAN1	Fixed Speed	100% ---- RPM
x	SYSFAN2	Fixed Speed	100% None
x	PWRFAN	Fixed Speed	100% None
x	CPU	Set Temp.	40° C
x	SYS	Set Temp.	30° C
x	PWR	Set Temp.	30° C
	CPUFAN	OS Speed	100% 4000 RPM
	SYSFAN1	OS Speed	100% ---- RPM
	SYSFAN2	OS Speed	100% None
	PWRFAN	OS Speed	100% None

Item Help

Menu Level ▶▶

This is initial fan speed when power-on. "50%" means half of full speed, "100%" means full speed.

Note:
During POST stage, the fan will be controlled by the mode you specified in the item "Fan Mode".

```
↑↓←→:Move Enter:Select +/-/PU/PD:Value F10:Save ESC:Exit F1:General Help
F2:Item Help F5:Previous Values F6:Setup Defaults F7:Turbo Defaults
```



The first image you have here is Voltage Status page. You can find current status of all voltages here and set your expected margins of warning level.

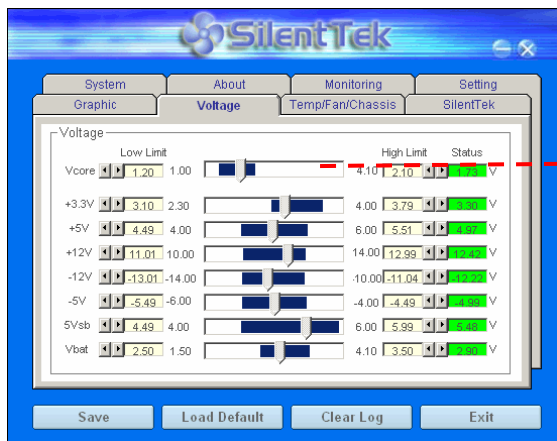

You may check your system voltage from the indicating bar here.

In "Temp/Fan/Case" page, you can get aware of the current temperature of CPU and the heat inside chassis. Also, you can check if fans are running properly.

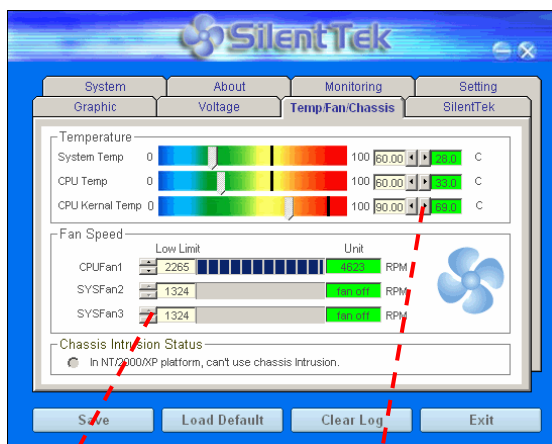

Of course, you can set your defaulted lowest margin for your fans and SilentTek will also pop up a message box to alarm you when the fan is rotating slower than this specified speed.

You can set the highest margin of your CPU and system temperature as default, and SilentTek will pop up a message box to alert you with an alarm when the temperature goes beyond the specified margin.

The following page is surely the most important part of this utility. You can control the rotation speed of specific fans that you have got the options inside this page.

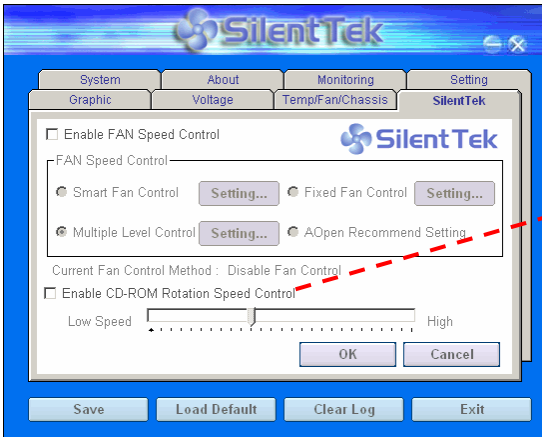

CD-ROM Rotation Speed Control: by enabling the CD-ROM Rotation Speed Control, you can adjust the rotation speed of your CD-ROM. When you set the speed to high level, the CD-ROM will work at its fastest speed and it will run at basic required speed while you set the value to low speed.

Smart FAN Control: This is the default setting of SilentTek and can be used for any branded computer housing. With a special algorithm developed by AOpen, the fan speed is automatically adjusted by the parameters of CPU and ambient temperature which is ease-of-use and trouble free at your service.

Fixed FAN Control: Under this setting, a desired fan speed is set fixed when operating.

Multiple Level Controls: This is the most versatile setting that allows you to set fan speed in relation to temperature. You may find that this setting fits you best.

AOpen Recommend Setting: This setting is designed specifically for AOpen housing. A series of lab tests were conducted under the real world scenario to determine optimum fan speed to reduce noise level within CPU working condition and temperature. Most of the time, the fan would remain still when CPU is not fully utilized.



Note: Due to hundreds brands of fans on market, inaccuracy may happen in some cases when you have your rotation speed adjusted. It is still under the criterion and please rest assured that it won't cause any problem to your system.

4.4 Other Useful Features

With excellent design ability of R&D team, AOpen boasts for its various powerful and handy features that come with our product like follows. You are welcomed to visit our technical website to learn more about those features.

<http://english.aopen.com.tw/tech/techinside>



Chapter 5 Setting BIOS

Introduction

System parameters can be modified by going into BIOS Setup menu; this menu allows you to configure the system parameters and save the configuration into the 128 bytes CMOS area (normally in the RTC chip or in the main chipset).

The Phoenix-Award BIOS™ that installed in the Flash ROM of the motherboard is a custom version of an industry standard BIOS. The BIOS provides critical low-level support for standard devices such as hard disk drives, serial and parallel ports.

AOpen's R&D engineering team had optimized most BIOS settings of this motherboard. However, some default settings of BIOS cannot fine-tune those sections that controlled by chipset. Therefore, this chapter is intended to guide you and help you to configure some other settings.

To enter BIOS setup menu, press when POST (Power-On Self Test) screen is shown on your monitor.



Note: Because BIOS code is the most often changed part on motherboard, the BIOS information contained in this manual may be different from the BIOS version that comes with your motherboard.



How To Use Phoenix-Award™ BIOS Setup Program

Generally, you can use arrow keys to highlight items that you want to choose, press <Enter> key to select, and use <Page Up> and <Page Down> keys to change setting values. You can press <Esc> key to quit Phoenix-Award™ BIOS setup program. The following table provides details about how to use keyboard in the Phoenix-Award™ BIOS setup program. Alternatively, it's strongly recommended to install AOpen's newest WinBIOS Utility to get more detailed description, further powerful functions and advanced setting of BIOS.

Key	Description
Page Up or +	Change setting to next value or increase the value.
Page Down or -	Change setting to previous value or decrease value.
Enter	Select the item.
Esc	In main menu: Quit without saving any changes. In sub menu: Exit current menu to main menu.
Up Arrow	Highlight previous item.
Down Arrow	Highlight next item.
Left Arrow	Move the light bar to left side of menu.
Right Arrow	Move the light bar to right side of menu.
F6	Load Setup Default setting value from CMOS.
F7	Load turbo setting value from CMOS.
F10	Save changed settings and exit setup program.

How To Enter BIOS Setup

After finishing the jumper settings and connecting cables, you can power on and enter the BIOS Setup. Press during POST (Power-On Self Test) and choose "Load Setup Defaults" for recommended optimal performance.

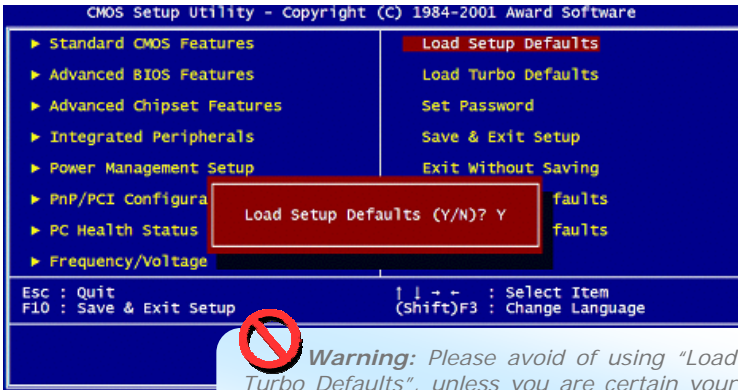

Warning: Please avoid of using "Load Turbo Defaults", unless you are certain your system components (CPU, SDRAM, HDD, etc.) are good enough for turbo setting.

BIOS Upgrade under Windows environment



With outstanding R&D ability of AOpen, we now bring you a whole new BIOS Flash wizard ---- EzWinFlash. With an eye to convenience for users, EzWinFlash combines the BIOS binary code and flash module together, so the only thing you have to do is just clicking on the utility you downloaded from web and let it help you complete the flash process automatically. EzWinFlash detects your motherboard and checks the BIOS version cleverly to prevent your system from any possible failure. Moreover, EzWinFlash has been taken into consideration to go with any windows platform you might be using, no matter if you're using Windows 95/98, 98SE/ME, NT4.0/2000, or Windows XP.

In the meanwhile, in order to provide a much more user-friendly operating environment, AOpen EzWinFlash is natively designed to have multi-language function to provide easier way for user in changing BIOS setting.



Caution: You are taking a risk of BIOS flash failure when you update your system. If your motherboard is working stable, and there are no major bugs to be fixed by a latter BIOS revision, we recommend that you **DO NOT** upgrade your BIOS. If you intent on upgrade **PLEASE MAKE SURE** you get the right BIOS revision for your motherboard model so as to avoid any possible failure.

Note: The model name on this BIOS picture is for reference only. It may not be the same model with your motherboard.



You may accomplish BIOS upgrade procedure with EzWinFlash according to following steps, and it's STRONGLY RECOMMENDED to close all applications before you start the upgrades.

Download the latest version of BIOS package zip file from AOpen official web site. (Ex: <http://english.aopen.com.tw/>)

Unzip the downloaded BIOS package (ex: WSGMAXII102.ZIP) with WinZip (<http://www.winzip.com>) in Windows environment.

Save the unzipped files into a folder, for example, WSGMAXII102.EXE & WSGMAXII102.BIN.

Double click WSGMAXII102.EXE; EzWinFlash will detect the model name and BIOS version of your motherboard. If you collect wrong BIOS, you will not be allowed to proceed with the flash steps.

You may select a preferred language in main menu, then click [Start Flash] to begin the BIOS upgrade procedure.

EzWinFlash will complete all the process automatically, and a dialogue box will pop up to ask you to restart Windows. Click [YES] to reboot Windows.

Press at POST to enter BIOS setup screen; choose "Load Setup Defaults", then "Save & Exit Setup". Done!

It is strongly recommended NOT to turn off the power or run any applications during FLASH PROCESS.



Warning: *The new BIOS upgrade will permanently replace your original BIOS setting when flashing. You may need to reconfigure the BIOS setting before your system goes back to work as normal.*



In the past, users have to keep punching the DEL key during POST (Power-On-Self-Test) screen to get into the BIOS, which is inconvenient and clumsy. From now on, AOpen provides an easier way to configure your BIOS. WinBIOS is a customized utility, running exclusively on AOpen motherboards, to allow you setting up BIOS under Windows environment. Designed to remain traditional-BIOS-alike interface, you can adjust BIOS parameter with clear descriptions for every item.

WinBIOS is natively designed with multi-language support. There are various widely-used languages provided on our website for you to download, which also helps to prevent wrong settings caused by misunderstanding of the languages. The only thing you have to do is to visit our official website and download your respective language pack (of few KB size), then double-click on it to activate the support with your chosen language.

Moreover, with high scalability, either for newly bought motherboard or the latest BIOS version with new function, you don't have to re-install the whole program again and again. All you have to do is to grab the latest profile from our website, double-click on the profile. You don't have to spend any extra effort to have your motherboard supported by WinBIOS.

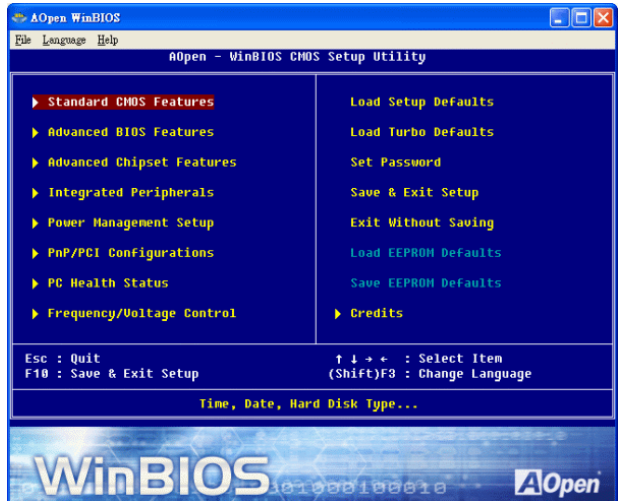

Vivid BIOS technology



Have you been fed up with the conservative and immutable POST screen? Let's rule out the tradition idea that POST screen are stiff and frigid, and let AOpen show you the newly developed VividBIOS to experience the lively vivid colorful POST screen!

Unlike earlier graphic POST screen which could occupy the whole screen and mask text information during POST, AOpen VividBIOS deals with graphics and texts separately, and makes them running simultaneously during POST. With this innovative design, VividBIOS now brings you a beautiful and sleek 256 colors screen without missing any important information shown on POST screen.

In addition, the limited space of BIOS ROM is another big issue. When all of the traditional BIOS can only show space-consuming and uncompressed Bitmap, AOpen has considerably tuned the BIOS to next generation, to recognize the smaller-sized GIF format and even dynamic-showing GIF animation.



Vivid BIOS shares the same fundamental technology with Open JukeBox CD Player, you may use the same EzSkin utility to change your VividBIOS screen or to download your favorite Open JukeBox skin. If you see this little logo shown beside



your model name on the motherboard download page, <http://english.aopen.com.tw/tech/ezskin/vivid.htm>, it is assured that your motherboard supports this innovative feature!

Chapter 6 Installing Drivers



You may think that installing drivers and utilities would be a repeated task of going through those installation wizards and steps-by-steps. Now, you will be surprised with how “Ez” EzInstall could do. Without wizards or steps, all you have to do is to do one click and then it’s done. Click and done. Yes. EzInstall makes installation easy and even foolproof!

After putting in the CD, you will be prompted with AOpen welcome page and our branches information.

First, click on the install driver ICON at left side for necessary drivers.

Second, click on the install utility ICON at left side for preferred utilities.

Practically, it’s done. But you may also browse CD contents, Readme to get more information or just exit the CD installation.

The screenshot shows the AOpen EzInstall welcome screen. On the left side, there is a vertical menu with five icons: a CD, a person with a laptop, a globe, a document, and a CD case. Callout boxes point to these icons with the following labels: "Install driver", "Install utility", "Browse CD Contents", "Readme", and "Exit CD". The main area of the screen displays the AOpen logo, a "Welcome" message, and contact information for various branches. A callout box points to a "Install User manual of your motherboard" icon in the top right corner with the text "Click to install online manual". Another callout box points to the contact information area with the text "AOpen branches information".

AOpen Inc. http://www.aopen.com.tw TEL: +886-2-3789-6888 FAX: +886-2-3789-6899	AOpen Computer GmbH. http://www.aopen.com.de TEL: +49-2131-1243-710 FAX: +49-2131-1243-999
AOpen America Inc. http://english.aopen.com.tw TEL: +1-408-232-1200 FAX: +1-408-232-1280	AOpen Japan Inc. http://www.aopen.co.jp TEL: +81-048-290-1800 FAX: +81-048-290-1820
AOpen Computer B.V. http://www.aopen.nl TEL: +31-73-645-9516 FAX: +31-73-645-9604	AOpen International Co., Ltd. http://www.aopen.com.cn TEL: +86-21-6225-8822 FAX: +86-21-6225-7826

6.1 Installing Drivers

As you may see from the Installing driver page, EzInstall had picked up necessary for your motherboard. All you have to do is just click on the "GO", and no more steps afterward, of all listed drivers, grey checks indicate necessary drivers; you cannot click them off. Red checks can be disabled if you don't want to install them now.



Press the icon will prompt the "Install Driver" page. You may also press "Back" to return to the Main page.

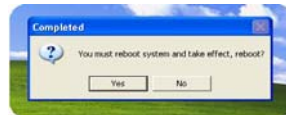

Once clicking "GO", EzInstall will run the installing procedure automatically, and prompt a reboot dialog (Some drivers or utilities may skip the reboot part).



Note: Due to the limitation of Intel chipsets driver, Windows 2000 is needed to be updated to service pack 4 for installing Audio driver correctly.

6.2 Installing Utilities

Installing Utilities is virtually the same as installing drivers. AOpen provides you many friendly and powerful utilities to manage your system. You may find lots of fabulous utilities listed there, and all you have to do is to click on the "GO", then it will install the utilities to your system right away without complicated steps.



Press the icon will prompt the "Install Utilities" page for your selection. You may also press "Back" to get back to the Main page.

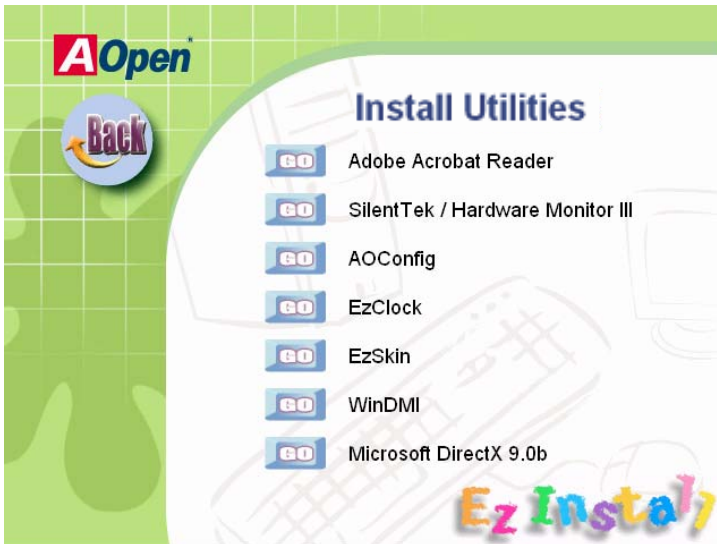



Troubleshooting

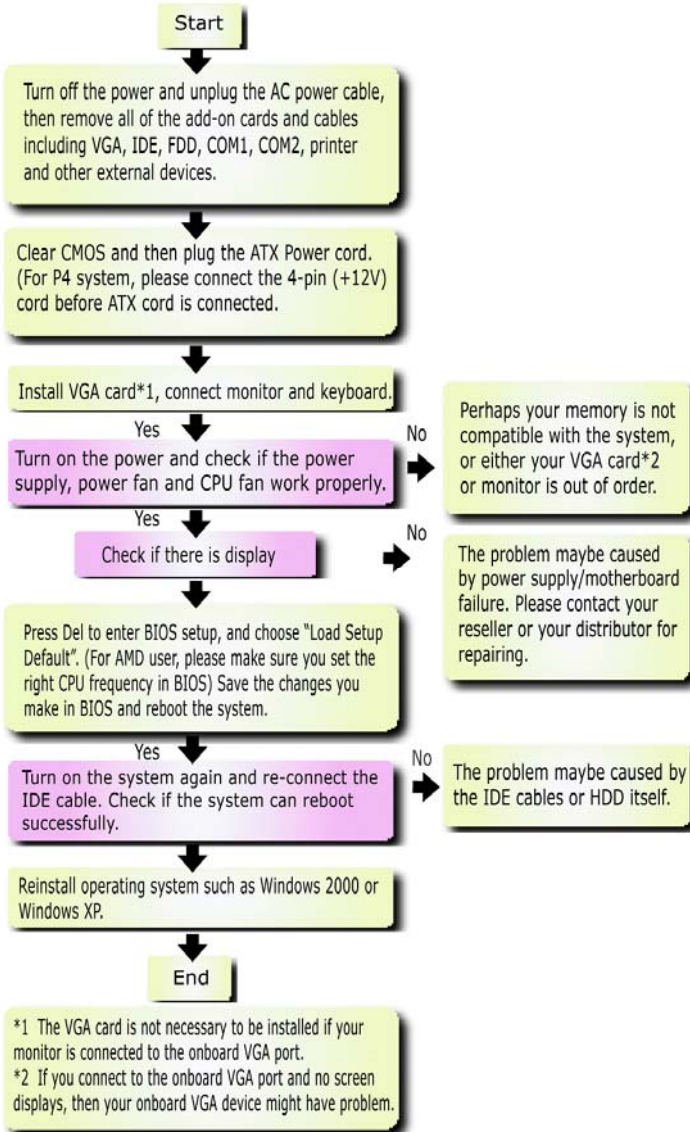

Chapter 8 Technical Support

Dear Customer,

Thanks for choosing AOpen products. We invite you to register at <http://www.aopen.com> to become a Gold Member of Club AOpen so as to ensure quality service in the future. In order to maintain the best service to every customer of us, we recommend you to follow the procedures below and seek help from our branches according to the region you buy the product. With your help, we can then continue to provide efficient and the best quality service to every customer.

Thanks very much for your understanding!

AOpen Technical Supporting Team

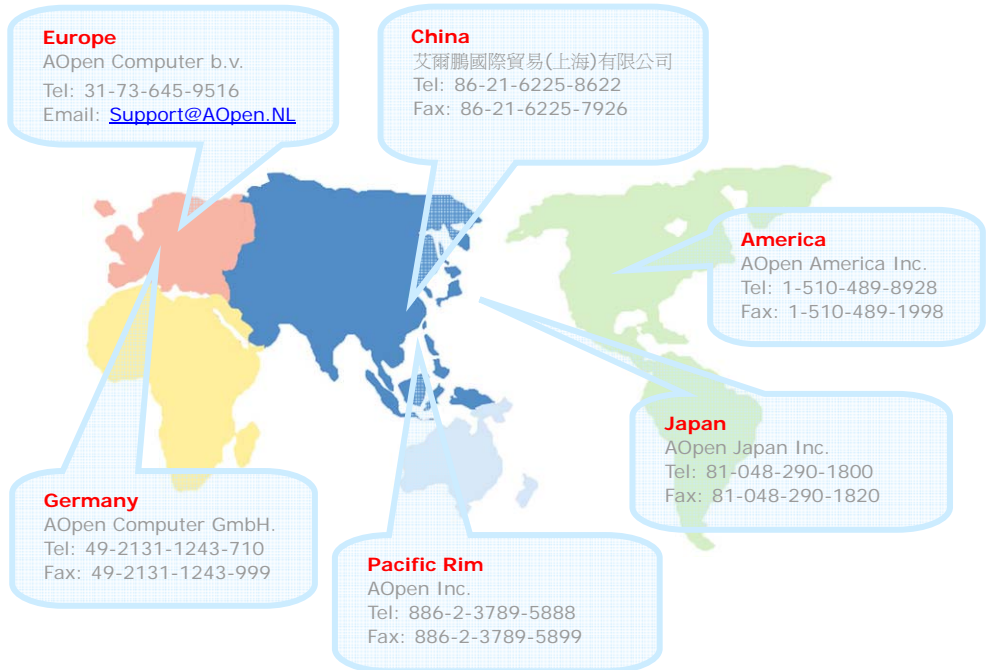

Europe Email: Support@AOpen.NL
Pacific Rim: <http://www.aopen.com.tw/tech/default.htm>
China: <http://www.aopen.com.cn/tech/default.htm>
Germany: <http://www.aopencom.de/tech/default.htm>
America: <http://usa.aopen.com/tech/default.htm>
Japan: <http://aopen.jp/tech/index.html>

Model Name and BIOS Version

Model name and BIOS version can be found on upper left corner of first boot screen (POST screen). For example:



I915Ga-EFRII is the model name of motherboard; R1.02 is BIOS version

Register Your Motherboard

Thanks for choosing AOpen product, please register this motherboard at <http://club.aopen.com.tw/productreg/> to become a Gold member of Club AOpen, and to ensure high service quality and priority from AOpen. You will also have a chance to play slot machine game to win prize from AOpen. Please prepare the following information before you start: Model Name, Part Number (P/N), Serial Number (S/N) and Purchase Date. The Part Number and Serial number are printed on bar code label. You can find this bar code label on the outside packing or on component side of PCB. For example:



Part No.

Serial No.

P/N: 91.88110.201 is part number, S/N: 91949378KN73 is serial number.

Phoenix-Award BIOS ERROR Message

Beep Sound	Message
1 short(Beep)	System booting is working normally.
1 long - 1 short(Beep)	DRAM error
1 long - 2 short(Beep)	Display card or monitor connection error
1 long - 3 short(Beep)	Keyboard error
Long(Beep) continuous	DRAM isn't installed correctly.



Technical Support

Online Manual: To download manual, please log on and then select your preferred language. Under "Type" directory, choose "Manuals" to go to our manual database. You can also find the manual and EIG in AOpen Bonus Pack.
<http://download.aopen.com.tw/downloads>

Test Report: We recommend you to choose board/card/device from the compatibility test reports for assembling your PC. It may prevent incompatibility problems.
<http://english.aopen.com.tw/tech/report/default.htm>

FAQ: Here we list problems that users often encounter and FAQ (Frequently Asked Questions). You may select your preferred language after log on, and may be able to find a solution to your problem.
<http://club.aopen.com.tw/faq/>

Download Software: After log on and having language selected, you may get the latest updated BIOS/utility and drivers you need under "Type" directory. In most case, newer versions of drivers and BIOS have solved earlier bugs or compatibility problems.
<http://download.aopen.com.tw/downloads>

eForum: AOpen eForum is provided to discuss our products with other users, in which your problem probably had been discussed before or will be answered. After log on, you may select your preferred language under "Multi-language".
<http://club.aopen.com.tw/forum>

Contact Us: Please prepare detail system configuration and error symptom before contacting us. The part number, serial number and BIOS version are also very helpful.

Contact Distributors/Resellers: We sell our products through resellers and integrators. They should know your system configuration very well and should be able to solve your problem efficiently and provide important reference for you.