

## **FCC Information and Copyright**

This equipment has been tested and found to comply with the limits of a Class B digital device, pursuant to Part 15 of the FCC Rules. These limits are designed to provide reasonable protection against harmful interference in a residential installation. This equipment generates, uses, and can radiate radio frequency energy and, if not installed and used in accordance with the instructions, may cause harmful interference to radio communications. There is no guarantee that interference will not occur in a particular installation.

The vendor makes no representations or warranties with respect to the contents here and specially disclaims any implied warranties of merchantability or fitness for any purpose. Further the vendor reserves the right to revise this publication and to make changes to the contents here without obligation to notify any party beforehand.

Duplication of this publication, in part or in whole, is not allowed without first obtaining the vendor's approval in writing.

The content of this user's manual is subject to be changed without notice and we will not be responsible for any mistakes found in this user's manual. All the brand and product names are trademarks of their respective companies.



### **Dichiarazione di conformità sintetica**

Ai sensi dell'art. 2 comma 3 del D.M. 275 del 30/10/2002

Si dichiara che questo prodotto è conforme alle normative vigenti e soddisfa i requisiti essenziali richiesti dalle direttive

2004/108/CE, 2006/95/CE e 1999/05/CE

quando ad esso applicabili

### **Short Declaration of conformity**

We declare this product is complying with the laws in force and meeting all the essential requirements as specified by the directives

2004/108/CE, 2006/95/CE and 1999/05/CE

whenever these laws may be applied

---

---

## Table of Contents

---

---

<b>Chapter 1: Introduction</b> .....	<b>1</b>
<b>1.1 Before You Start</b> .....	1
<b>1.2 Package Checklist</b> .....	1
<b>1.3 Motherboard Features</b> .....	2
<b>1.4 Rear Panel Connectors</b> .....	4
<b>1.5 Motherboard Layout</b> .....	5
<b>Chapter 2: Hardware Installation</b> .....	<b>6</b>
<b>2.1 Installing Central Processing Unit (CPU)</b> .....	6
<b>2.2 FAN Headers</b> .....	8
<b>2.3 Installing System Memory</b> .....	9
<b>2.4 Connectors and Slots</b> .....	11
<b>Chapter 3: Headers &amp; Jumpers Setup</b> .....	<b>14</b>
<b>3.1 How to Setup Jumpers</b> .....	14
<b>3.2 Detail Settings</b> .....	14
<b>Chapter 4: RAID / AHCI Functions</b> .....	<b>19</b>
<b>4.1 Operating System</b> .....	19
<b>4.2 Raid Arrays</b> .....	20
<b>4.3 How RAID Works</b> .....	21
<b>4.4 Intel Smart Response Technology</b> .....	25
<b>Chapter 5: UEFI BIOS &amp; Software</b> .....	<b>26</b>
<b>5.1 UEFI BIOS</b> .....	26
<b>5.2 Software</b> .....	29
<b>5.3 BIOS Update</b> .....	42
<b>Chapter 6: Useful Help</b> .....	<b>47</b>
<b>6.1 Driver Installation Note</b> .....	47
<b>6.2 Extra Information</b> .....	48
<b>6.3 AMI BIOS Post Code</b> .....	49
<b>6.4 Troubleshooting</b> .....	51
<b>Appendix: SPEC In Other Languages</b> .....	<b>52</b>
<b>German</b> .....	52
<b>French</b> .....	54
<b>Italian</b> .....	56
<b>Spanish</b> .....	58
<b>Portuguese</b> .....	60
<b>Polish</b> .....	62
<b>Russian</b> .....	64
<b>Arabic</b> .....	66
<b>Japanese</b> .....	68

## **CHAPTER 1: INTRODUCTION**

### **1.1 BEFORE YOU START**

Thank you for choosing our product. Before you start installing the motherboard, please make sure you follow the instructions below:

- Prepare a dry and stable working environment with sufficient lighting.
- Always disconnect the computer from power outlet before operation.
- Before you take the motherboard out from anti-static bag, ground yourself properly by touching any safely grounded appliance, or use grounded wrist strap to remove the static charge.
- Avoid touching the components on motherboard or the rear side of the board unless necessary. Hold the board on the edge, do not try to bend or flex the board.
- Do not leave any unfastened small parts inside the case after installation. Loose parts will cause short circuits which may damage the equipment.
- Keep the computer from dangerous area, such as heat source, humid air and water.
- The operating temperatures of the computer should be 0 to 45 degrees Celsius.

### **1.2 PACKAGE CHECKLIST**

- ✚ Serial ATA Cable x4
- ✚ Rear I/O Panel for ATX Case x1
- ✚ User's Manual x1
- ✚ Fully Setup Driver DVD x1
- ✚ SLI Bridge x1
- ✚ CFX Bridge x1
- ✚ Calibration Microphone x1

<b>Note:</b> The package contents may be different due to area or your motherboard version.
---

### 1.3 MOTHERBOARD FEATURES

SPEC		
CPU	Socket 1155 Intel Core i7 / i5 / i3 / Pentium / Celeron processor (TDP: 95W)	Supports Execute Disable Bit / Enhanced Intel SpeedStep® / Intel Architecture-64 / Extended Memory 64 Technology / Virtualization Technology / Hyper Threading
Chipset	Intel Z77	
Super I/O	IT8728F Provides the most commonly used legacy Super I/O functionality. Low Pin Count Interface	Environment Control initiatives, Hardware Monitor Controller Fan Speed Controller ITE's "Smart Guardian" function
Main Memory	DDR3 DIMM Slots x 4 Max Memory Capacity 32GB Each DIMM supports 512MB/ 1GB/2GB/4GB/8GB DDR3	Dual Channel Mode DDR3 memory module Supports DDR3 1066 / 1333 / 1600 Supports DDR3(OC) 1800/ 1866/ 2000/ 2133/ 2200/ 2400/ 2600 Registered DIMM and ECC DIMM is not supported
SATA 2 & 3	Integrated Serial ATA Controller	Data transfer rates up to 3.0 Gb/s / 6.0 Gb/s. SATA Version 2.0 / 3.0 specification compliant RAID 0,1,5,10, SRT support
LAN	Realtek RTL 8111F	10 / 100 Mb/s / 1Gb/s auto negotiation Half / Full duplex capability
Sound Codec	ALC898	7.1 channels audio out High Definition Audio, Biostar Hi-Fi
USB3.0	Z77	Data transfer rates up to 600 MB/s
Slots	PCI Express Gen3 x 16 slot (Depending on CPU) x2 PCI Express Gen2 x 16 slot(x4) x1 PCI Express Gen2 x 1 slot x3	Supports PCI-E Gen3 x16 expansion card Supports SLI / CFX (x8, x8) Supports PCI-E Gen2 x16 expansion card Supports PCI-E Gen2 x1 expansion cards

<i>SPEC</i>			
On Board Connectors	SATA3 Connector	x2	Each connector supports 1 SATA3 devices
	SATA2 Connector	x4	Each connector supports 1 SATA2 devices
	Front Panel Connector	x1	Supports front panel facilities
	Front Audio Connector	x1	Supports front panel audio function
	CPU Fan Header	x1	CPU Fan power supply (with Smart Fan function)
	System Fan Header	x2	System Fan Power supply
	Clear CMOS Header	x1	Restore CMOS data to factory default
	USB2.0 Connector	x2	Each connector supports 2 front panel USB2.0 ports
	USB3.0 Connector	x1	Each connector supports 2 front panel USB3.0 ports
	Consumer IR Connector	x1	Supports infrared function
	Serial Port Connector	x1	Connects to RS-232 Port
	S/PDIF out Connector	x1	Supports digital audio out function
	Power Connector (24pin)	x1	Connects to Power supply
Power Connector (8pin)	x1	Connects to Power supply	
Back Panel I/O	PS/2 Keyboard/ Mouse	x1	Connects to PS/2 Keyboard/ Mouse
	HDMI Port	x1	Connects to HDMI cable
	VGA Port	x1	Connect to D-SUB monitor
	DVI Port	x1	Connect to DVI monitor
	LAN port	x1	Connect to RJ-45 ethernet cable
	USB2.0 Port	x4	Connect to USB2.0 devices
	USB3.0 Port	x2	Connect to USB3.0 devices
Audio Jack	x6	Provide Audio-In/Out and Mic. connection	
Board Size	244 (W) x 305 (L) mm		ATX
OS Support	Windows XP / Vista / 7/ 8		Biostar reserves the right to add or remove support for any OS with or without notice

## 1.4 REAR PANEL CONNECTORS

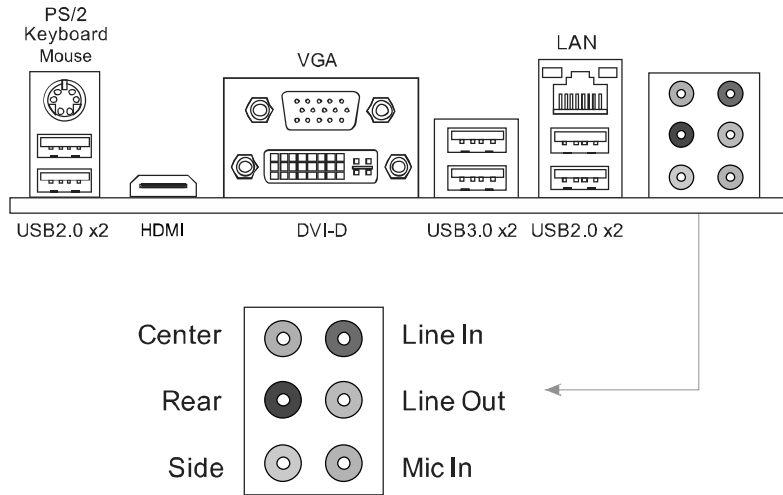

**Note1:** HDMI, DVI-D & VGA ports only work with an Intel integrated Graphics Processor

**Note2:** USB3.0 ports (only supported by Windows 7/8) are backward compatible with USB2.0/USB1.X devices.

**Note3:** Maximum resolution:  
 HDMI: 1920 x 1200 @60Hz, compliant with HDMI 1.4a  
 DVI: 1920 x 1200 @60Hz  
 VGA: 2048 x 1536 @75Hz

**Note4:** This motherboard supports dual video output:

Display Devices	VGA	DVI-D	HDMI
VGA	X	O	O
DVI-D	O	X	O
HDMI	O	O	X

## 1.5 MOTHERBOARD LAYOUT

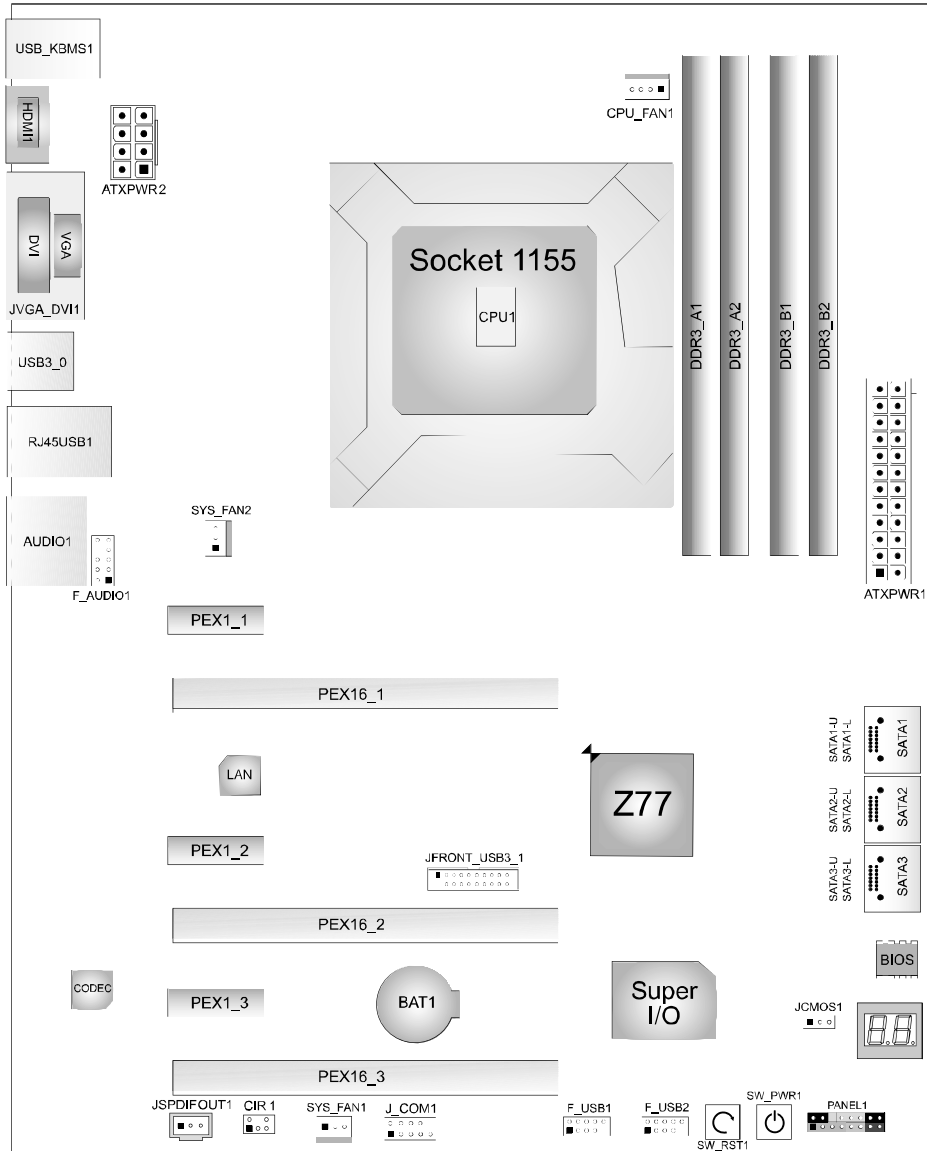

Note: ■ represents the 1<sup>st</sup> pin.

## CHAPTER 2: HARDWARE INSTALLATION

### 2.1 INSTALLING CENTRAL PROCESSING UNIT (CPU)

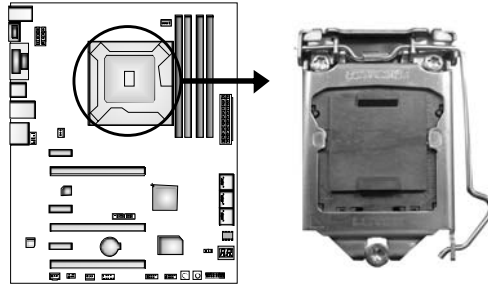

**Notice:**

1. Remove Pin Cap before installation, and make good preservation for future use. When the CPU is removed, cover the Pin Cap on the empty socket to ensure pin legs won't be damaged.
2. The motherboard might equip with two different types of pin cap. Please refer below instruction to remove the pin cap.

**Step 1:** Pull the socket locking lever out from the socket and then raise the lever up.

Type A

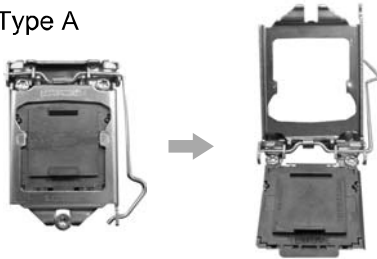

Type B

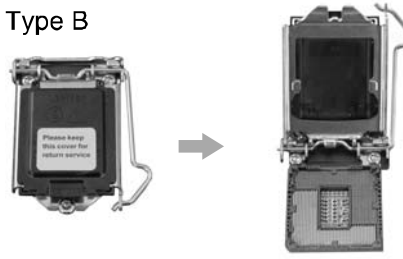

**Step 2:** Remove the Pin Cap.

Type A

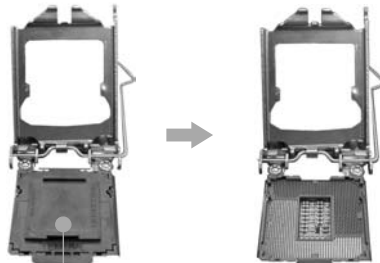

Pin Cap

Type B

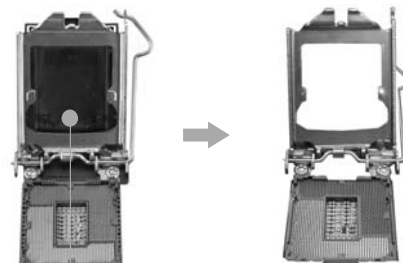

Pin Cap



**Step 3:** Hold processor with your thumb and index fingers, oriented as shown. Align the notches with the socket. Lower the processor straight down without tilting or sliding the processor in the socket.



**Step 4:** Hold the CPU down firmly, and then lower the lever to locked position to complete the installation.



**Step 5:** Put the CPU Fan and heatsink assembly on the CPU and buckle it on the retention frame. Connect the CPU FAN power cable into the CPU\_FAN1 to complete the installation.

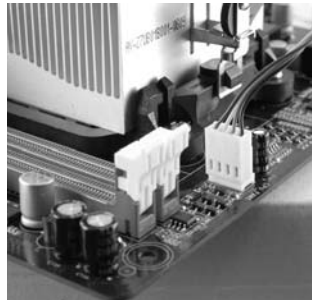

## 2.2 FAN HEADERS

These fan headers support cooling-fans built in the computer. The fan cable and connector may be different according to the fan manufacturer. Connect the fan cable to the connector while matching the black wire to pin#1.

### CPU\_FAN1: CPU Fan Header

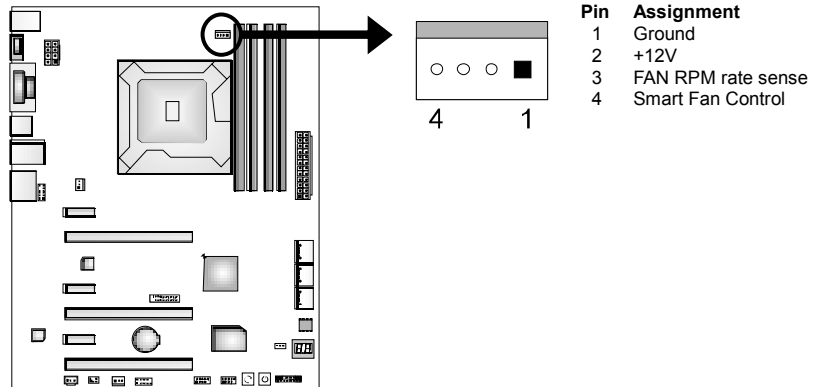

### SYS\_FAN1/SYS\_FAN2: System Fan Headers

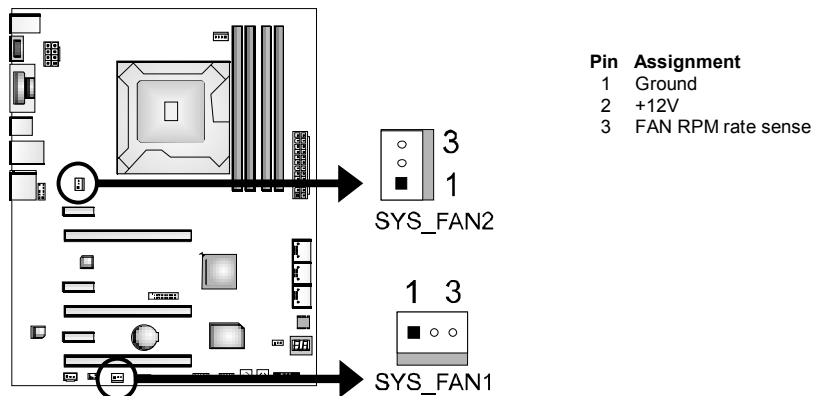

**Note:**

The SYS\_FAN1/SYS\_FAN2 support 3-pin head connectors; the CPU\_FAN1 supports 4-pin head connector. When connecting with wires onto connectors, please note that the red wire is the positive and should be connected to pin#2, and the black wire is Ground and should be connected to GND.

## 2.3 INSTALLING SYSTEM MEMORY

### A. Memory Modules

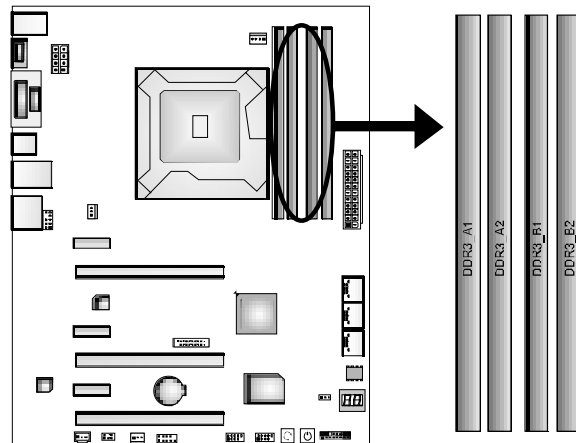

1. Unlock a DIMM slot by pressing the retaining clips outward. Align a DIMM on the slot such that the notch on the DIMM matches the break on the Slot.

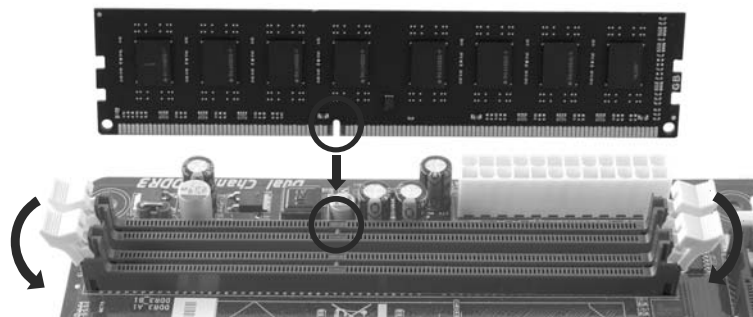

## Motherboard Manual

2. Insert the DIMM vertically and firmly into the slot until the retaining chip snap back in place and the DIMM is properly seated.

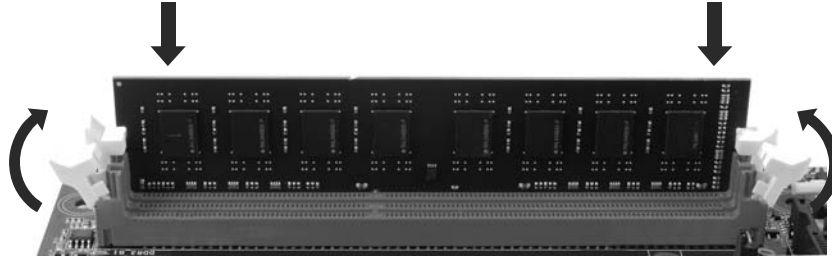

**Note:** If the DIMM does not go in smoothly, do not force it. Pull it all the way out and try again.

### B. Memory Capacity

DIMM Socket Location	DDR3 Module	Total Memory Size
DDR3_A1	512MB/1GB/2GB/4GB/8GB	Max is 32GB.
DDR3_A2	512MB/1GB/2GB/4GB/8GB	
DDR3_B1	512MB/1GB/2GB/4GB/8GB	
DDR3_B2	512MB/1GB/2GB/4GB/8GB	

### C. Dual Channel Memory Installation

Please refer to the following requirements to activate Dual Channel function:

Install memory module of the same density in pairs, shown in the table.

Dual Channel Status	DDR3_A1	DDR3_A2	DDR3_B1	DDR3_B2
Enabled	O	X	O	X
Enabled	X	O	X	O
Enabled	O	O	O	O
Enabled	O	X	X	O
Enabled	X	O	O	X

(O means memory installed, X means memory not installed.)

**Note:** The DRAM bus width of the memory module must be the same (x8 or x16)

## 2.4 CONNECTORS AND SLOTS

### SATA1: Serial ATA3.0 Connectors

These connectors connect to SATA hard disk drives via SATA cables. Those satisfy the SATA 3.0 spec and with transfer rate of 6.0Gb/s.

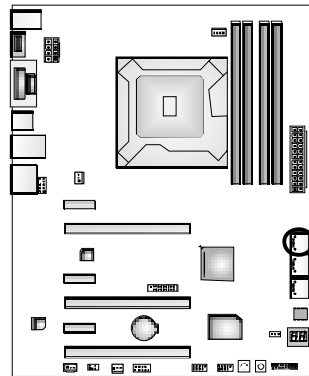

Pin	Assignment
1	Ground
2	TX+
3	TX-
4	Ground
5	RX-
6	RX+
7	Ground

### SATA2/3: Serial ATA2.0 Connectors

These connectors connect to SATA hard disk drives via SATA cables. Those satisfy the SATA 2.0 spec and with transfer rate of 3.0Gb/s.

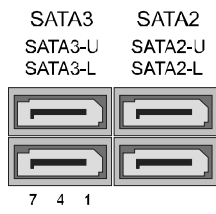
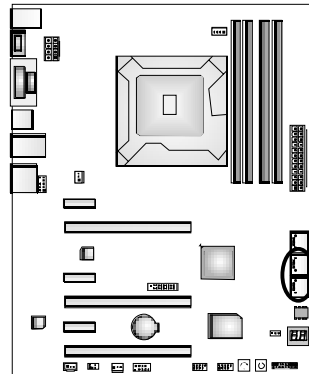

Pin	Assignment
1	Ground
2	TX+
3	TX-
4	Ground
5	RX-
6	RX+
7	Ground

**PEX16\_1/ PEX16\_2: PCI-Express Gen3 x16 (x16 / x8) (Nvidia SLI and AMD CrossFireX) Slots**

- PCI-Express 3.0 compliant.
- Maximum theoretical realized bandwidth of 8GB/s simultaneously per direction, for an aggregate of 16GB/s totally.
- The speed of PEX16\_1 is x16 or x8 when SLI or CFX is enabled. The speed of PEX16\_2 is x8.
- PCI-E 3.0 is supported by Core i7-3xxx / i5-3xxx CPU.

**Note:** For more details about Nvidia SLI and AMD CrossFireX, please access the website, respectively: <http://www.nvidia.com/page/support.html>, and <http://support.amd.com/us/Pages/AMDSupportHub.aspx>.

**PEX16\_3: PCI-Express Gen2 x4 Slot**

- PCI-Express 2.0 compliant.
- Maximum theoretical realized bandwidth of 2GB/s simultaneously per direction, for an aggregate of 4GB/s totally.

**PEX1\_1/PEX1\_2/PEX1\_3: PCI-Express Gen2 x1 Slot**

- PCI-Express 2.0 compliant.
- Data transfer bandwidth up to 500MB/s per direction; 1GB/s in total.

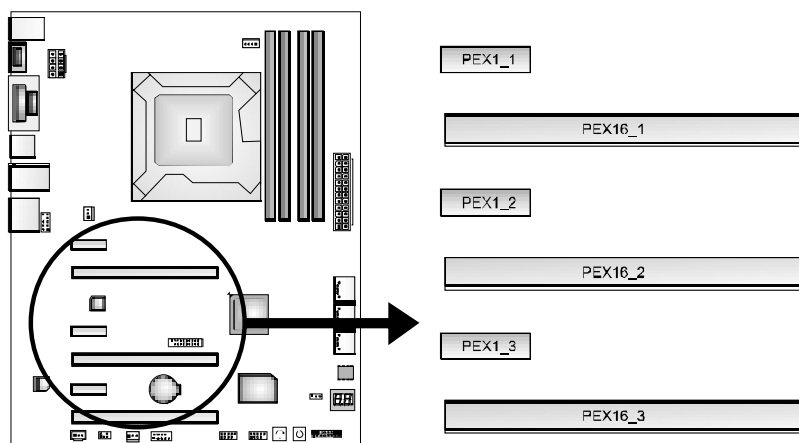

### ATXPWR2: ATX Power Source Connectors

These connectors provide +12V to CPU power circuit. If the CPU power plug is 4-pin, please plug it into Pin 1-2-5-6 of ATXPWR2.

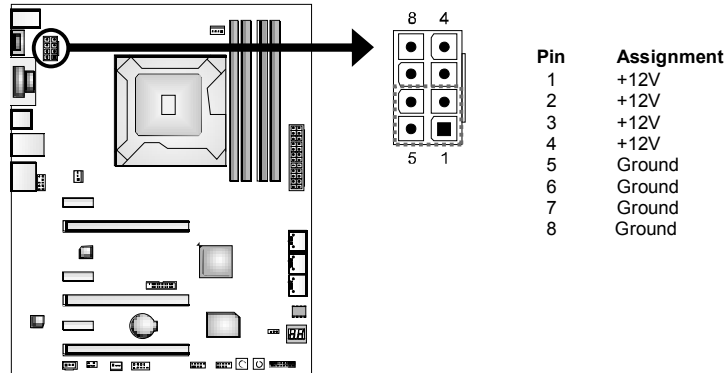

### ATXPWR1: ATX Power Source Connector

This connector allows user to connect 24-pin power connector on the ATX power supply.

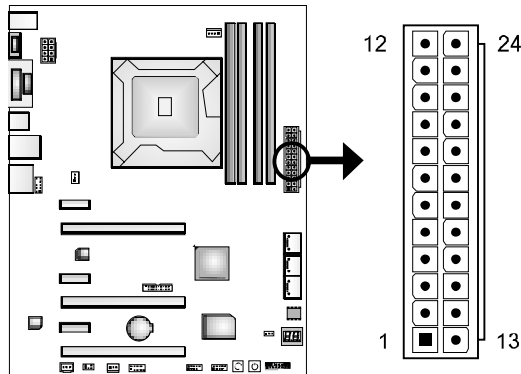

Pin	Assignment	Pin	Assignment
13	+3.3V	1	+3.3V
14	-12V	2	+3.3V
15	Ground	3	Ground
16	PS_ON	4	+5V
17	Ground	5	Ground
18	Ground	6	+5V
19	Ground	7	Ground
20	NC	8	PW_OK
21	+5V	9	Standby Voltage+5V
22	+5V	10	+12V
23	+5V	11	+12V
24	Ground	12	+3.3V

**Note:** Before you power on the system, please make sure that ATXPWR1 and ATXPWR2 connectors have been well plugged-in.

## CHAPTER 3: HEADERS & JUMPERS SETUP

### 3.1 HOW TO SETUP JUMPERS

The illustration shows how to set up jumpers. When the jumper cap is placed on pins, the jumper is “close”, if not, that means the jumper is “open”.



### 3.2 DETAIL SETTINGS

#### PANEL1: Front Panel Header

This 16-pin connector includes Power-on, Reset, HDD LED, Power LED, and speaker connection. It allows user to connect the PC case’s front panel switch functions.

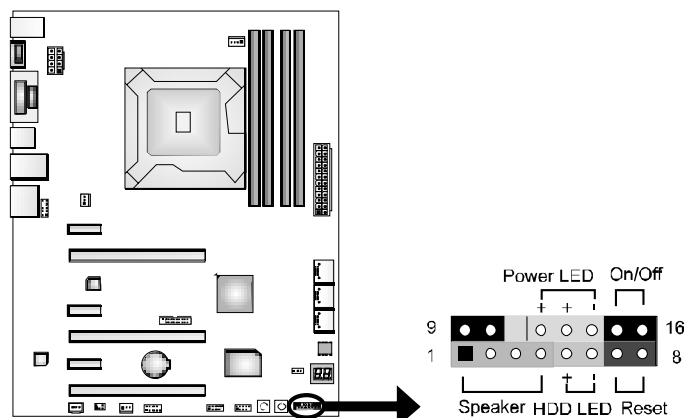

Pin	Assignment	Function	Pin	Assignment	Function
1	+5V	Speaker Connector	9	N/A	N/A
2	N/A		10	N/A	N/A
3	N/A		11	N/A	N/A
4	Speaker	Hard drive LED	12	Power LED (+)	Power LED
5	HDD LED (+)		13	Power LED (+)	
6	HDD LED (-)		14	Power LED (-)	
7	Ground	Reset button	15	Power button	Power-on button
8	Reset control		16	Ground	



**F\_USB1/F\_USB2: Headers for USB 2.0 Ports at Front Panel**

These headers allow user to connect additional USB cable on the PC front panel, and also can be connected with internal USB devices, like USB card reader.

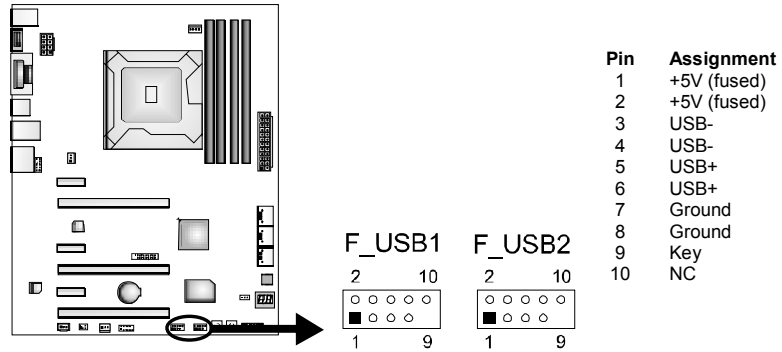

**JFRONT\_USB3\_1: Header for USB 3.0 Ports at Front Panel**

This header allows user to connect additional USB cable on the PC front panel, and also can be connected with internal USB devices, like USB card reader.

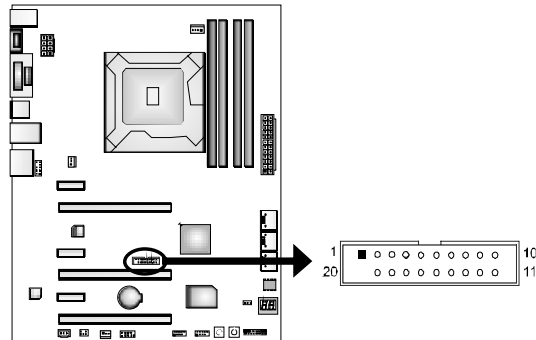

Pin	Assignment	Pin	Assignment
1	VBUS0	11	D2+
2	SSRX1-	12	D2-
3	SSRX1+	13	Ground
4	Ground	14	SSTX2+
5	SSTX1-	15	SSTX2-
6	SSTX1+	16	Ground
7	Ground	17	SSRX2+
8	D1-	18	SSRX2-
9	D1+	19	VBUS1
10	ID	20	Key

**Note:** USB3.0 is only supported by Windows 7/8.

### F\_AUDIO1: Front Panel Audio Header

This header allows user to connect the front audio output cable with the PC front panel. This header supports HD and AC'97 audio front panel connector.

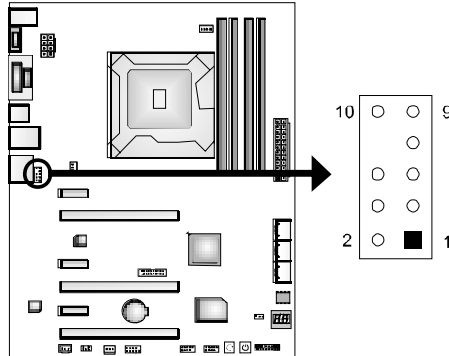

HD Audio		AC'97	
Pin	Assignment	Pin	Assignment
1	Mic Left in	1	Mic In
2	Ground	2	Ground
3	Mic Right in	3	Mic Power
4	GPIO	4	Audio Power
5	Right line in	5	RT Line Out
6	Jack Sense	6	RT Line Out
7	Front Sense	7	Reserved
8	Key	8	Key
9	Left line in	9	LFT Line Out
10	Jack Sense	10	LFT Line Out

**Note1:** It is recommended that you connect a high-definition front panel audio module to this connector to avail of the motherboard's high definition audio capability.  
**Note2:** Please try to disable the "Front Panel Jack Detection" if you want to use an AC'97 front audio output cable. The function can be found via O.S. Audio Utility.

### JSPDIFOUT1: Digital Audio-out Connector

This connector allows user to connect the PCI bracket SPDIF output header.

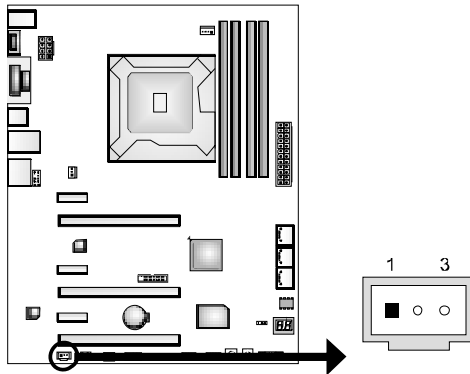

Pin	Assignment
1	+5V
2	SPDIF_OUT
3	Ground

### CIR1: Consumer IR Connector

This header is for infrared remote control and communication.

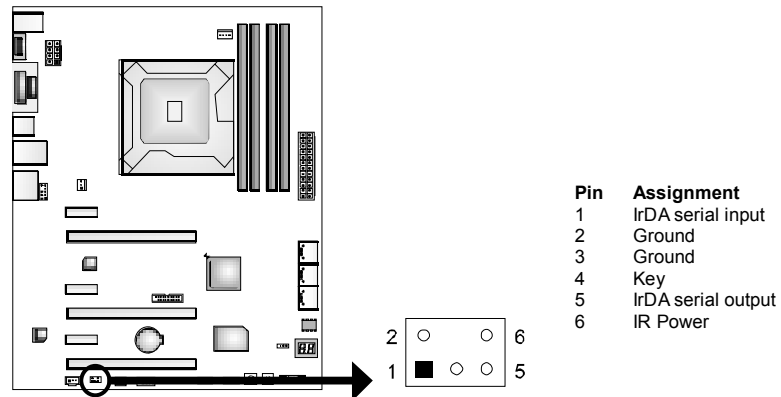

### JCMOS1: Clear CMOS Header

Placing the jumper on pin2-3 allows user to restore the BIOS safe setting and the CMOS data. Please carefully follow the procedures to avoid damaging the motherboard.

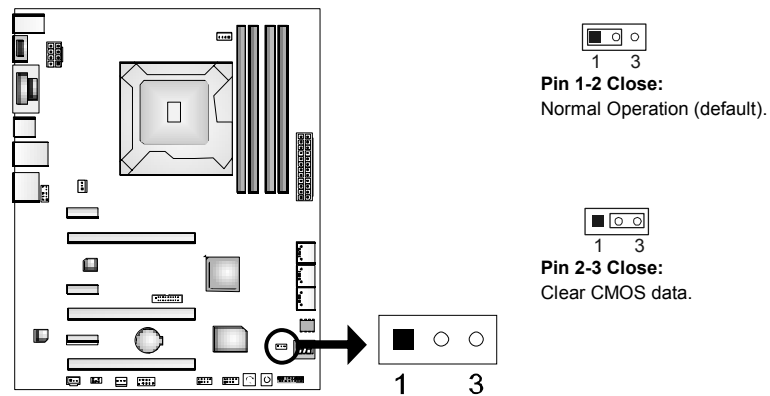

#### ※ Clear CMOS Procedures:

1. Remove AC power line.
2. Set the jumper to "Pin 2-3 close".
3. Wait for five seconds.
4. Set the jumper to "Pin 1-2 close".
5. Power on the AC.
6. Reset your desired password or clear the CMOS data.

### J\_COM1: Serial Port Connector

The motherboard has a Serial Port Connector for connecting RS-232 Port.

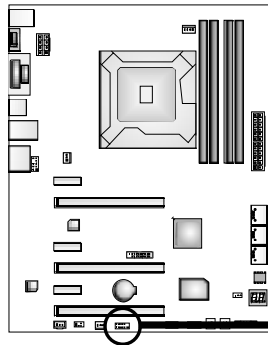

Pin	Assignment
1	Carrier detect
2	Received data
3	Transmitted data
4	Data terminal ready
5	Signal ground
6	Data set ready
7	Request to send
8	Clear to send
9	Ring indicator
10	NC

### BIOS POST Code/CPU Temperature Indicator

This indicator will show POST code while booting. After the booting sequence, it will show current CPU temperature. Please refer to Chapter 6.3 for all the BIOS POST codes.

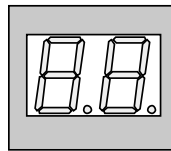
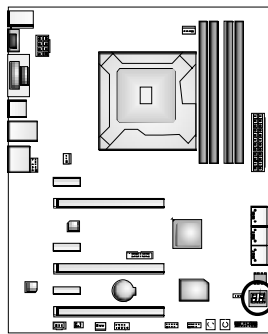

### On-Board Buttons

There are 2 on-board buttons.

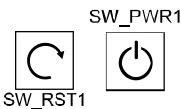
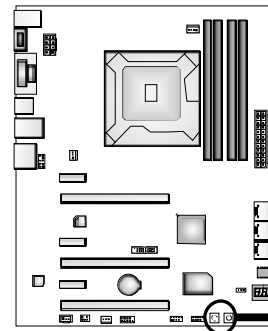

**SW\_RST1:** Reset button.  
**SW\_PWR1:** Power Switch button.

## CHAPTER 4: RAID / AHCI FUNCTIONS

### 4.1 OPERATING SYSTEM

CHIP	SATA Controller Configuration	OS
Intel Z77 SATA1-U/SATA1-L/ SATA2-U/SATA2-L/ SATA3-U/SATA3-L/	AHCI	Windows XP SP2 (32 and 64 bit) Windows Vista SP2 (32 and 64 bit) Windows 7/8 (32 and 64 bit)
Intel Z77 SATA1-U/SATA1-L/ SATA2-U/SATA2-L/ SATA3-U/SATA3-L/	RAID	Windows XP SP2 (32 and 64 bit) Windows Vista SP2 (32 and 64 bit) Windows 7/8 (32 and 64 bit)

#### The 'F6 Method'+ to enable RAID / AHCI Driver when installing Windows XP

1. Before you start Windows installation, copy the proper files for the Windows version on USB floppy.

	Windows XP 32	Windows XP 64
SATA1-U/SATA1-L/ SATA2-U/SATA2-L/ SATA3-U/SATA3-L/ AHCI/RAID Driver Path	x:\Driver\Chipset\Intel\SATA\7\F6flpy32\Driver\	x:\Driver\Chipset\Intel\SATA\7\F6flpy64\Driver\

2. When the operating system installation starts, follow Windows indication by pressing F6 to load the driver.

## Motherboard Manual

### Enable RAID / AHCI Driver when installing Windows 8/7/Vista

1. Before you start Windows installation, copy the proper files for the Windows version to any USB storage.

	Windows 7/ Vista 32	Windows 7/ Vista 64	Windows 8 32	Windows 8 64
SATA1-U/SATA1-L/ SATA2-U/SATA2-L/ SATA3-U/SATA3-L/ AHCI/RAID Driver Path	x:\Driver\Chipset\ Intel\SATA\7\ F6flpy32\Driver\ 	x:\Driver\Chipset\ Intel\SATA\7\ F6flpy64\Driver\ 	x:\Driver\Chipset\ Intel\SATA\ Win8\F6flpy32\ Driver\ 	x:\Driver\Chipset\ Intel\SATA\ Win8\F6flpy64\ Driver\ 

2. Follow Window 7 / Vista indication to load the driver in the installation process.

## 4.2 RAID ARRAYS

CONNECTOR	BY CHIP	SPEED	Support
SATA1-U/SATA1-L	Intel Z77	6 Gb/s.	RAID 0 / 1 / 5 / 10
SATA2-U/SATA2-L SATA3-U/SATA3-L	Intel Z77	3 Gb/s.	RAID 0 / 1 / 5 / 10

RAID supports the following types of RAID arrays:

**RAID 0:** RAID 0 defines a disk striping scheme that improves disk read and write times for many applications.

**RAID 1:** RAID 1 defines techniques for mirroring data.

**RAID 10:** RAID 10 combines the techniques used in RAID 0 and RAID 1.

**RAID 5:** RAID 5 provides fault tolerance and better utilization of disk capacity.

### 4.3 How RAID WORKS

#### **RAID 0:**

The controller “stripes” data across multiple drives in a RAID 0 array system. It breaks up a large file into smaller blocks and performs disk reads and writes across multiple drives in parallel. The size of each block is determined by the stripe size parameter, which you set during the creation of the RAID set based on the system environment. This technique reduces overall disk access time and offers high bandwidth.

#### **Features and Benefits**

- **Drives:** Minimum 2, and maximum is up to 6 or 8. Depending on the platform.
- **Uses:** Intended for non-critical data requiring high data throughput, or any environment that does not require fault tolerance.
- **Benefits:** provides increased data throughput, especially for large files. No capacity loss penalty for parity.
- **Drawbacks:** Does not deliver any fault tolerance. If any drive in the array fails, all data is lost.
- **Fault Tolerance:** No.
- **Total Capacity:** (Minimal. HDD Capacity) x (Connected HDDs Amount)

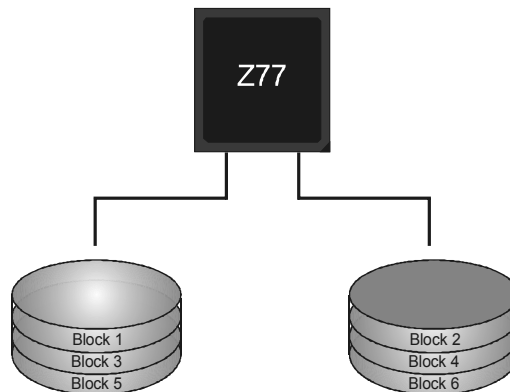

**RAID 1:**

Every read and write is actually carried out in parallel across 2 disk drives in a RAID 1 array system. The mirrored (backup) copy of the data can reside on the same disk or on a second redundant drive in the array. RAID 1 provides a hot-standby copy of data if the active volume or drive is corrupted or becomes unavailable because of a hardware failure. RAID techniques can be applied for high-availability solutions, or as a form of automatic backup that eliminates tedious manual backups to more expensive and less reliable media.

**Features and Benefits**

- **Drives:** Minimum 2, and maximum is 2.
- **Uses:** RAID 1 is ideal for small databases or any other application that requires fault tolerance and minimal capacity.
- **Benefits:** Provides 100% data redundancy. Should one drive fail, the controller switches to the other drive.
- **Drawbacks:** Requires 2 drives for the storage space of one drive. Performance is impaired during drive rebuilds.
- **Fault Tolerance:** Yes.

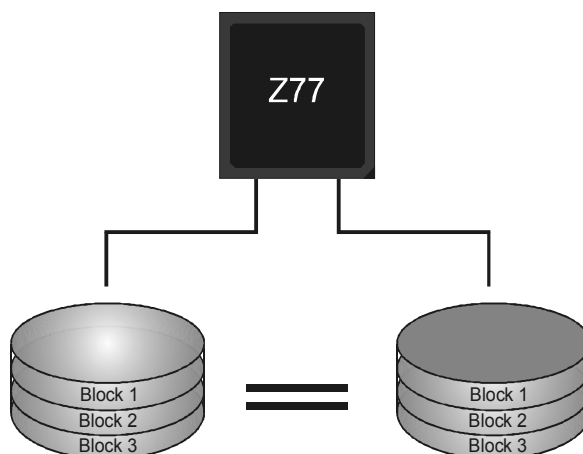



**RAID 10:**

RAID 1 drives can be striped using RAID 0 techniques. Resulting in a RAID 10 solution for improved resiliency performance and rebuild performance.

**Features and Benefits**

- **Drives:** Minimum 4, and maximum is 6 or 8, depending on the platform.
- **Benefits:** Optimizes for both fault tolerance and performance, allowing for automatic redundancy. May be simultaneously used with other RAID levels in an array, and allows for spare disks.
- **Drawbacks:** Requires twice the available disk space for data redundancy, the same as RAID level 1.
- **Fault Tolerance:** Yes.

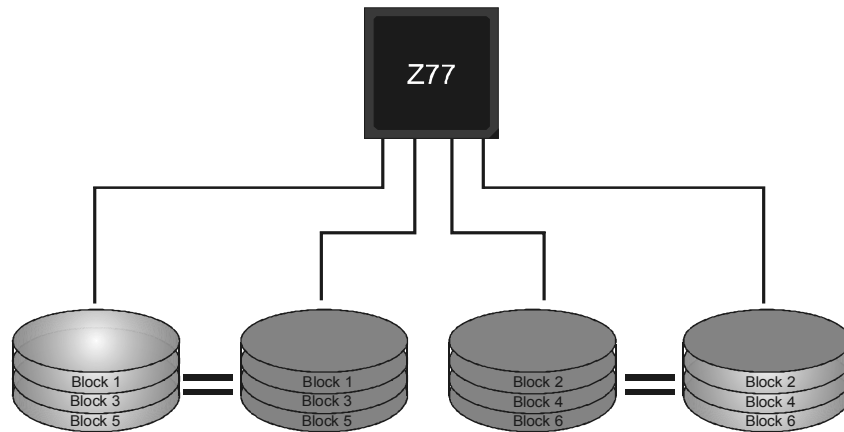

**RAID 5:**

RAID 5 stripes both data and parity information across three or more drives. It writes data and parity blocks across all the drives in the array. Fault tolerance is maintained by ensuring that the parity information for any given block of data is placed on a different drive from those used to store the data itself.

**Features and Benefits**

- **Drives:** Minimum 3.
- **Uses:** RAID 5 is recommended for transaction processing and general purpose service.
- **Benefits:** An ideal combination of good performance, good fault tolerance, and high capacity and storage efficiency.
- **Drawbacks:** Individual block data transfer rate same as a single disk. Write performance can be CPU intensive.
- **Fault Tolerance:** Yes.

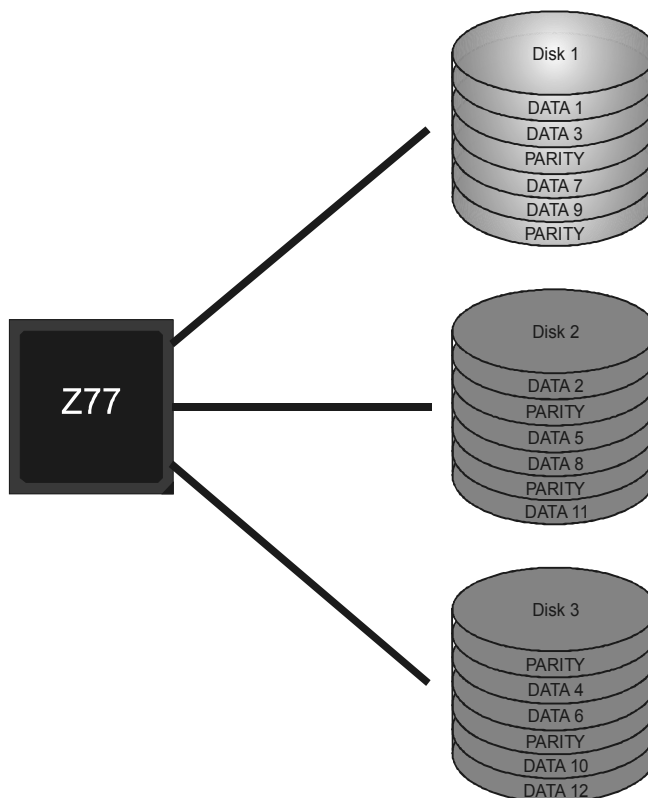

#### **4.4 INTEL SMART RESPONSE TECHNOLOGY**

With Intel(R) Smart Response Technology, the performance of RAID with an Intel SSD drive can be improved better.

##### ***Installing Smart Response Technology***

1. Install RAID drives (RAID 0, 1, 5) and an Intel SSD.
2. Activate RAID mode from BIOS, and install operating system.
3. Insert the Setup DVD to the optical drive, and Install all drivers (including Intel(R) Smart Response Technology Driver). After all processes finish, reboot the system.
4. Intel(R) SRT service icon will show in notification area. Double click it to open the main windows.
5. Select "Accelerate" page, and make sure the status of accelerated device has been enabled accelerated.

## CHAPTER 5: UEFI BIOS & SOFTWARE

### 5.1 UEFI BIOS

#### UEFI BIOS Features

- Overclocking Navigator Engine (O.N.E.)
- Self Recovery System (S.R.S)
- Smart Fan Function
- BIO-Flasher: Update UEFI BIOS file from USB Flash Drive

#### !! WARNING!!

For better system performance, the UEFI BIOS firmware is being continuously updated. The UEFI BIOS information described below in this manual is for your reference only and the actual UEFI BIOS information and settings on board may be different from this manual. For further information of setting up the UEFI BIOS, please refer to the UEFI BIOS Manual in the Setup DVD.

#### A. Overclocking Navigator Engine (O.N.E.)

O.N.E provides 4 systems allowing users to customize personal overclock settings: Manual CPU System, Manual Memory System, Manual PWM System, and Manual Voltage System.



**Note1:** Not all types of CPU perform above overclock setting ideally; the difference will be based on the selected CPU model.

**Note2:** Overclock is an optional process, but not a "must-do" process; it is not recommended for inexperienced users. Therefore, we will not be responsible for any hardware damage which may be caused by overclocking. We also would not guarantee any overclocking performance.

### B. Self Recovery System (S.R.S.)

This function can't be seen under UEFI BIOS setup, and is always on whenever the system starts up.

However, it can prevent system hang-up due to inappropriate overclock actions.

When the system hangs up, S.R.S. will automatically log in the default UEFI BIOS setting, and all overclock settings will be re-configured.

### C. Smart Fan Function

Smart Fan Function is under "Smart Fan Control" in "Advanced Menu".

This is a brilliant feature to control CPU/System Temperature vs. Fan speed.

When enabling Smart Fan function, Fan speed is controlled automatically by CPU/System temperature.

This function will protect CPU/System from overheat problem and maintain the system temperature at a safe level.



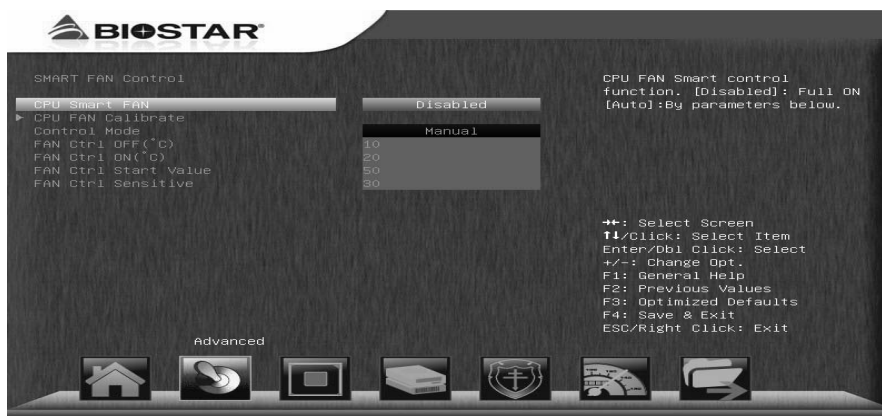

### CPU Smart FAN

This item allows you to control the CPU Smart Fan function.

### CPU FAN Calibrate

Press [ENTER] to calibrate CPU FAN.

### Control Mode

This item provides several operation modes of the fan.

### Fan Ctrl OFF(°C)

When CPU temperature is lower than this value, the CPU fan will keep lowest RPM. The range is from 0~50, with an interval of 1.

### Fan Ctrl On(°C)

When CPU temperature is higher than this value, the CPU fan controller will turn on. The range is from 0~70, with an interval of 1.

### Fan Ctrl Start Value

This item sets CPU FAN Start Speed Value. The range is from 0~255, with an interval of 1.

### Fan Ctrl Sensitive

The bigger the numeral is, the higher the FAN speed is. The range is from 1~255, with an interval of 1.

## 5.2 SOFTWARE

### *Installing Software*

1. Insert the Setup DVD to the optical drive. The driver installation program would appear if the Auto-run function has been enabled.
2. Select **Software Installation**, and then click on the respective software title.
3. Follow the on-screen instructions to complete the installation.

### *Launching Software*

After the installation process is completed, you will see the software icon showing on the desktop. Double-click the icon to launch it.

### *TOverclocker*

TOverclocker presents a simple Windows-based system performance enhancement and manageability utility. It features several powerful and easy to use tools such as Overclocking for enhancing system performance, also for special enhancement on CPU and Memory. Smart-Fan management and PC health are for monitoring system status. This utility also allows you to make overclocking profiles saving unlimitedly, and pre-set OC modes are for easy OC. (The illustration below is for reference only)

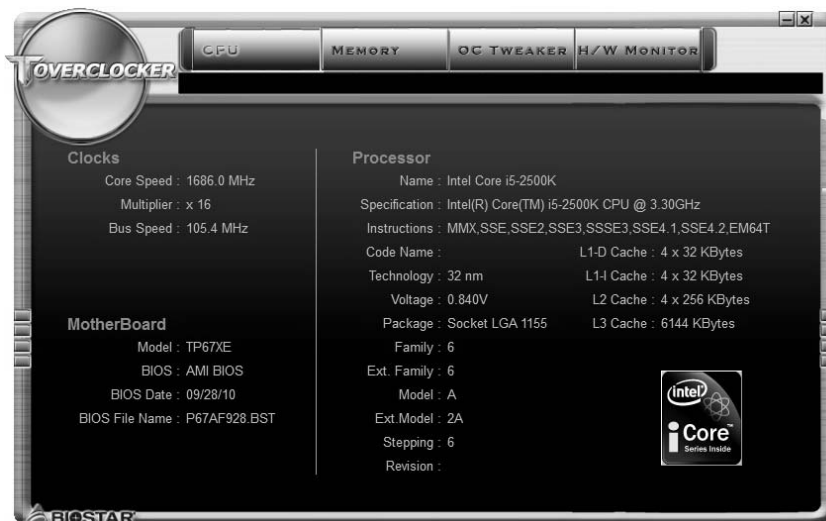

## Motherboard Manual

---



The **CPU** tab provides information on the CPU and motherboard.



The **Memory** tab provides information on the memory module(s).

You can select memory module on a specific slot to see its information.



The **OC Tweaker** tab allows you to change system clock settings and voltages settings. It also provides six pre-set modes for you:





**3 Pre-set Modes: V6, V12, AUTO for different overclocking experience.**

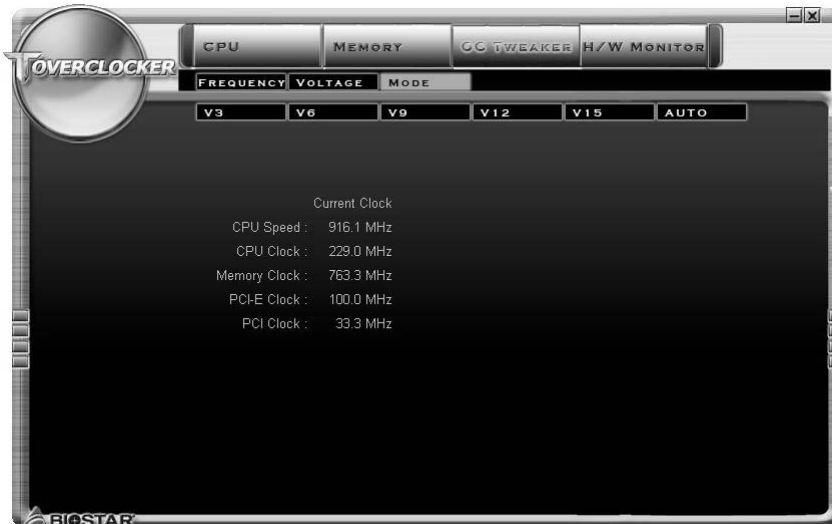

The **HW Monitor** tab allows you to monitor hardware voltage, fan speed, and temperature. Besides, you also can set related values for CPU Smart Fan.





Pressing **TOVERCLOCKER** logo displays information about manufacturer and software version. You can update current version by clicking the button “Live Update.”

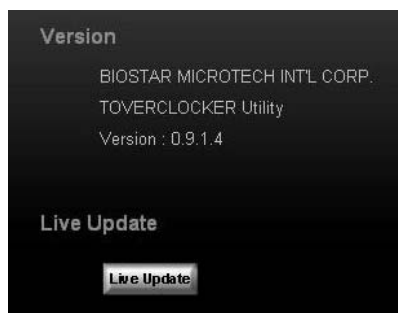

### Green Power II Utility

BIOSTAR G.P.U II (Green Power Utility) is a new function. The utility enhances energy efficiency by disabling extra phases while CPU is on light loading; it features 4+1 power phases, current power saving, and total power saving. This tool integrates a friendly GUI to monitor your CPU Usage, CPU Watt, and CPU Temperature. Moreover, it optimizes power saving and best power efficiency on your system. (The illustration below is for reference only)

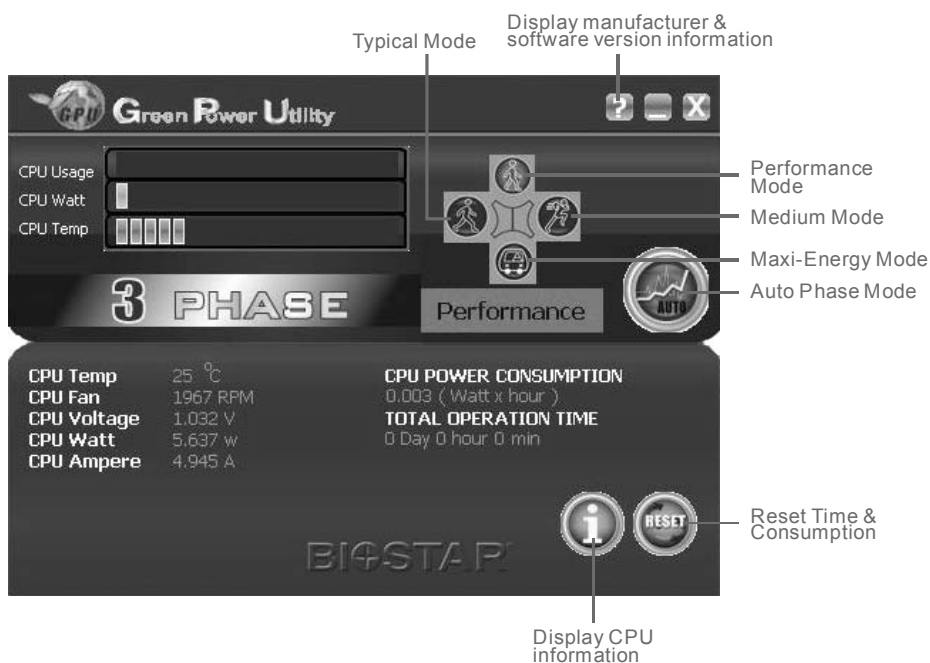

### **G.P.U Mode Setting**

This utility provides five modes, upon your requirements, to improve system performance or to save power consumption.

**Note:** Even if the modes saving more power consumption are chosen, the system still can keep excellent performance.

- **Auto Phase Mode**

System switches the mode automatically according to current system loading condition.

- **Performance Mode**

This is the mode saving power consumption most. Least energy will be used in the system.

- **Typical Mode**

Compared with that in Performance Mode, energy consumption in this mode is a little bit more.

- **Medium Mode**

This is the standard system power saving mode.

- **Maxi-Energy Mode**

This is the best system performance mode.

### Smart EAR

Smart EAR is a windows-based audio utility which allows you to easily adjust system volume. With its user-friendly GUI, you can also adjust impedance setting (Low/High Gain) to optimize your headphone performance.

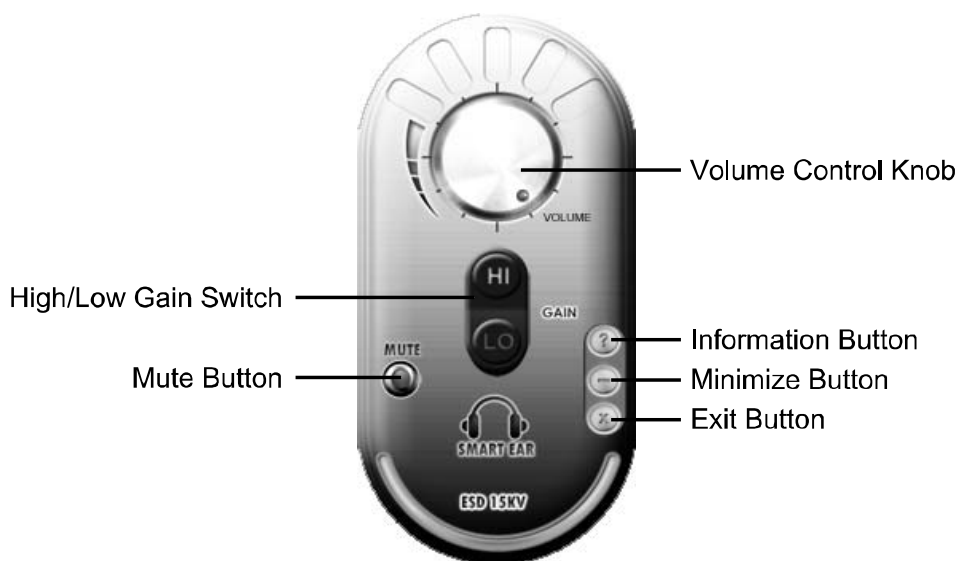

- **High/Low Gain Switch:** Keep the gain switch to low for low impedance headphone and set to high for high impedance headphone.
- **Mute Button:** To disable system sound
- **Volume Control Knob:** The volume can be finely adjusted by turning the knob either clockwise or anti-clockwise to increase or decrease system volume accordingly.
- **Information Button:** Get information of the application
- **Minimize Button:** Minimize the application window to the taskbar
- **Exit Button:** Exit the application

**Note:**

1. Smart EAR is only supported by Windows 7/8 and BIOSTAR Hi-Fi series motherboards.
2. High/Low Gain Switch is only for "Front Panel Audio Header", please make sure you are connecting your headphone to the front panel I/O.

### Multi Channels Calibration (MCC)

Multi Channels Calibration (MCC) can transform any room into the ideal listening environment. With Multi Channels Calibration(MCC), audio performance is automatically calibrated according to the dimensions of your room.

**Take a note of following precautions before you start the calibration.**

1. Do not connect or disconnect the speaker setup microphone and speakers during the calibration.
2. Do not stand between the speakers and microphone, and avoid obstacles blocking the path between speakers and microphone.
3. Turn off all media players and do not adjust any audio settings (ex. volume or mute) in your operating system.
4. MCC software is only supported by Windows 7/8 and BIOSTAR Hi-Fi series motherboards.

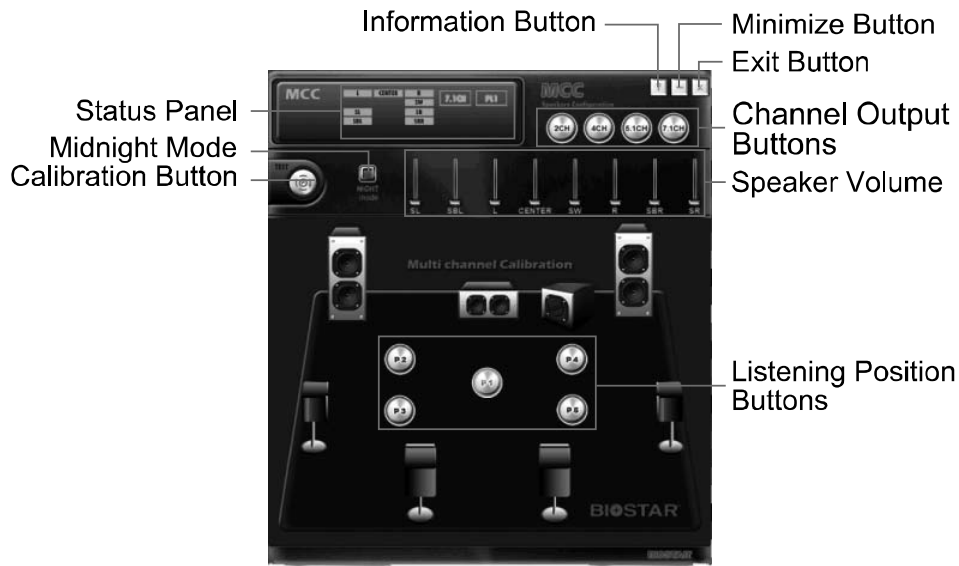

- **Status Panel:** Show the information of speakers and listening positions.
- **Midnight Mode:** Turn on this function will let you enjoy a movie quietly without compromising sound qualities, surround effects and dialogue clarity.
- **Calibration Button:** Start or stop the calibration.
- **Channel Output Buttons:** Select the channel output (2/ 4/ 5.1/ 7.1-channel)
- **Listening Position Buttons:** It allows you setup five listening positions.
- **Speaker Volume:** Show each speaker's volume.
- **Information Button:** Get information of the application.
- **Minimize Button:** Minimize the application window to the taskbar.
- **Exit Button:** Exit the application.

**Start the Calibration:**

**Step 1:**

Install and launch Multi Channels Calibration software

**Step 2:**

Arrange and connect the speakers in your room.

**Step 3:**

Select the channel output (2/ 4/ 5.1/ 7.1-channel) for the speak configuration.

**Step 4:**

Place the speaker setup microphone at ear height of a seated listener in your room and connection it to Mic In jack.

**Note:**

To setup 5.1-channel for a motherboard with 3 audio jacks, please connect the speaker setup microphone to front panel Mic-In.

**Step 5:**

Select your preferred listening position and click the “Listening Position Button”.

**Step 6:**

Click the “Calibration Button”. You can see a notice window then click “Next” to start the calibration. The test tone will be played through each speakers and it will take 2-3 minutes to process the calibration. Please make the room as quiet as possible at the meantime.

**Step 7:**

After completing calibration, you will see a finish window then click “OK” to exit this calibration.

**Audio Ports:**

For the definition of each audio port, please refer to the table below:

**The 2/ 4/ 5.1-channel configuration for 3 audio jacks**

Port	2-channel	4-channel	5.1 channel
Blue	Line In	Rear Speaker Out	Rear Speaker Out
Green	Line Out	Front Speaker Out	Front Speaker Out
Pink	Mic In	Mic In	Center/Subwoofer Out

**The 2/ 4/ 5.1/ 7.1-channel configuration for 6 audio jacks**

Port	2-channel	4-channel	5.1 channel	7.1 channel
Blue	Line In	Line In	Line In	Line In
Green	Line Out	Front Speaker Out	Front Speaker Out	Front Speaker Out
Pink	Mic In	Mic In	Mic In	Mic In
Orange	--	--	Center/Subwoofer Out	Center/Subwoofer Out
Black	N/A	Rear Speaker Out	Rear Speaker Out	Rear Speaker Out
Grey	--	--	--	Side Speaker Out

### ***Guide of Lucid VIRTU MVP Installation***

With Lucid VIRTU MVP solution, the resource and performance of graphics can be integrated so that user can choose the suitable mode for the requirement.

#### ***System Requirements***

- **CPU:** CPU with integrated graphics support
- **Chipset:** Any chipset with integrated graphics output
- **Discrete GPU:** Any Nvidia/AMD GPU with DX9/DX10/DX11 support
- **Memory Size:** 2GB
- **Operating System:** Windows 7/8 32-bit and 64-bit
- **Hard Disk Space:** 20MB

#### ***BIOS Setting***

Please try to set Onboard VGA (IGD) as first display if you want to use the i-mode.

#### ***i-Mode & d-Mode***

- 1. i-Mode:** i-Mode provides user with near zero performance overhead on 3D graphics games, Virtual VSync and Hyperformance features, integrated GPU special features and power saving options when no 3D gaming is used. To use Lucid VIRTU Universal MVP solution in i-Mode, display must be always connected to motherboard video output.
  
- 2. d-Mode:** d-Mode is provided for demanding 3D gamers to achieve uncompromised 3D performance of discrete GPU installed in the system, along with Virtual VSync and Hyperformance quality/performance improvement features. In this mode, Virtu Universal MVP allows user to utilize integrated GPU special features such as transcoding, while display is connected to discrete GPU.

**Note1:** In most cases the differences of 3D performance between i-Mode and d-Mode are unnoticeable to the user, so it is recommended to use i-mode to save power.

**Note2:** To use Lucid VIRTU Universal MVP solution in d-Mode, display must be connected to discrete GPU installed in the system.

**Software Installation**

1. Install VGA Driver and VIRTU MVP Software.



2. If for some reason auto-activation process fails, or the internet is not available for 30 days, user will have to manually activate Virtu Universal MVP by pressing “**Activate**” button through the Internet.



3. When Virtu Universal MVP successfully activates, the screen will look like this.



4. After installation, please restart the computer. The left screenshot is control panel.



### eHot-Line (Optional)

eHot-Line is a convenient utility that helps you to contact with our Tech-Support system. This utility will collect the system information which is useful for analyzing the problem you may have encountered, and then send these information to our tech-support department to help you fix the problem.

 Before you use this utility, please set Outlook Express as your default e-mail client application program.

\* represents important information that you must provide. Without this information, you may not be able to send out the mail.

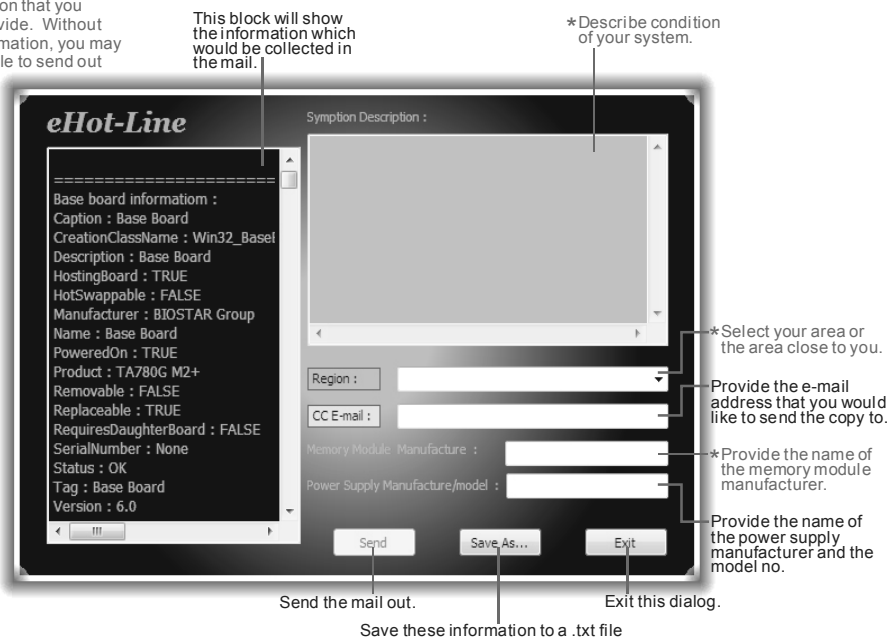

This block will show the information which would be collected in the mail.

\* Describe condition of your system.

\* Select your area or the area close to you.

Provide the e-mail address that you would like to send the copy to.

\* Provide the name of the memory module manufacturer.

Provide the name of the power supply manufacturer and the model no.

Send the mail out.

Save these information to a .txt file

Exit this dialog.

After filling up this information, click **“Send”** to send the mail out. A warning dialog would appear asking for your confirmation; click **“Send”** to confirm or **“Do Not Send”** to cancel.



If you want to save this information to a .txt file, click **“Save As...”** and then you will see a saving dialog appears asking you to enter file name.

Enter the file name and then click “Save”. Your system information will be saved to a .txt file.

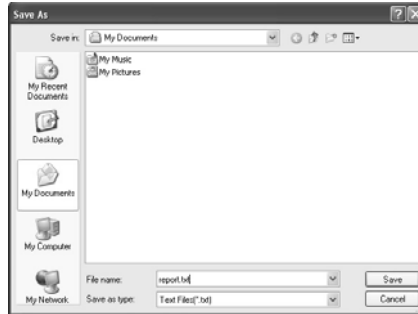

Open the saved .txt file, you will see your system information including motherboard/BIOS/CPU/video/device/OS information. This information is also concluded in the sent mail.



**We will not share customer’s data with any other third parties,** so please feel free to provide your system information while using eHot-Line service.



If you are not using Outlook Express as your default e-mail client application, you may need to save the system information to a .txt file and send the file to our tech support with other e-mail application.

### ***BIOScreen Utility (Optional)***

This utility allows you to personalize your boot logo easily. You can choose JPG or BMP as your boot logo so as to customize your computer.



Please follow the following instructions to update boot logo:

1. **Load Image** : Choose the picture as the boot logo.
2. **Transform** : Transform the picture for BIOS and preview the result.
3. **Update Bios** : Write the picture to BIOS Memory to complete the update.

### 5.3 BIOS UPDATE

There are three ways to update the BIOS:  
BIOS Update Utility, BIOS Online Update Utility and BIOS Flasher.

#### 1. BIOS Update Utility

1. Installing BIOS Update Utility from the DVD Driver.
2. Download the proper BIOS from [www.biostar.com.tw](http://www.biostar.com.tw).

3. Open BIOS Update Utility and click the **Update BIOS** button on the main screen.



4. A warning message will show up to request your agreement to start the BIOS update. Click **Yes** to start the update procedure.

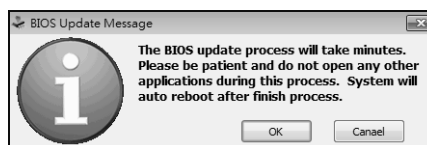

5. Choose the location for your BIOS file in the system. Please select the proper BIOS file, and then click on **Open**. It will take several minutes, please be patient.

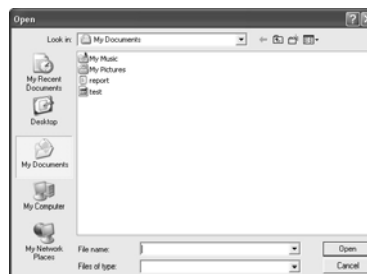

6. After the BIOS Update process is finished, click on **OK** to reboot the system.

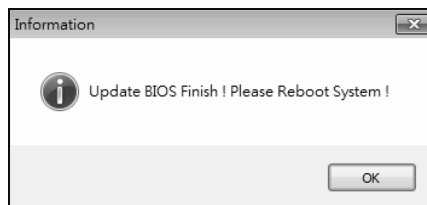

7. While the system boots up and the full screen logo shows up, please press the **Del** <Delete> key to enter BIOS setup.

After entering the BIOS setup, please go to the **Save & Exit**, using the **Restore Defaults** function to load Optimized Defaults, and select **Save Changes and Reset** to restart the computer. Then, the BIOS Update is completed.

### Backup BIOS

Click the Backup BIOS button on the main screen for the backup of BIOS, and select a proper location for your backup BIOS file in the system, and click **Save**.

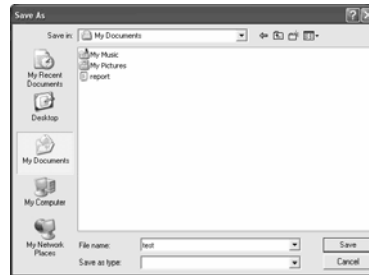

## 2. Online Update Utility

1. Installing BIOS Update Utility from the DVD Driver.
2. Please make sure the system is connected to the internet before using this function.

3. Open BIOS Update Utility and click the **Online Update** button on the main screen.



4. An open dialog will show up to request your agreement to start the BIOS update. Click **Yes** to start the online update procedure.

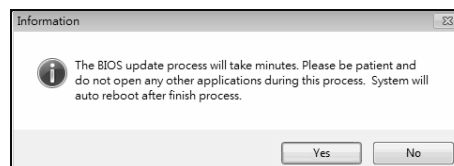

5. If there is a new BIOS version, the utility will ask you to download it. Click **Yes** to proceed.

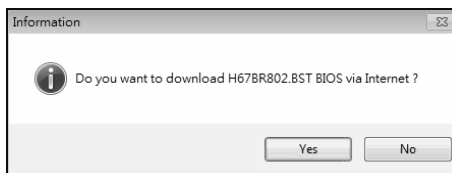

6. After the download is completed, you will be asked to program (update) the BIOS or not. Click **Yes** to proceed.

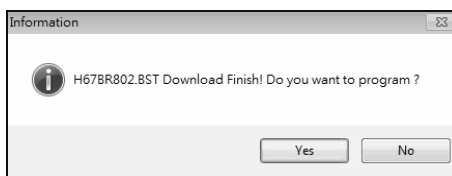

7. After the updating process is finished, you will be asked you to reboot the system. Click **OK** to reboot.

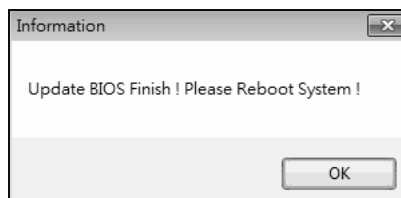

8. While the system boots up and the full screen logo shows up, press  <Delete> key to enter BIOS setup.

After entering the BIOS setup, please go to the **Save & Exit**, using the **Restore Defaults** function to load Optimized Defaults, and select **Save Changes and Reset** to restart the computer. Then, the BIOS Update is completed.

### 3. BIOSTAR BIOS Flasher

BIOSTAR BIOS Flasher is a BIOS flashing utility providing you an easy and simple way to update your BIOS via USB pen drive.



- This utility only allows storage device with FAT32/16 format and single partition.
- Shutting down or resetting the system while updating the BIOS will lead to system boot failure.

The BIOSTAR BIOS Flasher is built in the BIOS ROM. To enter the utility, **press <F12> during the Power-On Self Tests (POST) procedure** while booting up.

#### Updating BIOS with BIOSTAR BIOS Flasher

1. Go to the website to download the latest BIOS file for the motherboard.
2. Then, copy and save the BIOS file into a USB flash (pen) drive.
3. Insert the USB pen drive that contains the BIOS file to the USB port.
4. Power on or reset the computer and then press <F12> during the **POST** process.

5. After entering the POST screen, the BIOS-FLASHER utility pops out. Choose [fs0] to search for the BIOS file.



6. Select the proper BIOS file, and a message asking if you are sure to flash the BIOS file. Click Yes to start updating BIOS.



7. A dialog pops out after BIOS flash is completed, asking you to restart the system. Press the [Y] key to restart system.



8. While the system boots up and the full screen logo shows up, press  <Delete> key to enter BIOS setup.

After entering the BIOS setup, please go to the **Save & Exit**, using the **Restore Defaults** function to load Optimized Defaults, and select **Save Changes and Reset** to restart the computer. Then, the BIOS Update is completed.



All the information and content about above software are subject to be changed without notice. For better performance, the software is being continuously updated. The information and pictures described above are for your reference only. The actual information and settings on board may be slightly different from this manual.



## CHAPTER 6: USEFUL HELP

### 6.1 DRIVER INSTALLATION NOTE

After you installed your operating system, please insert the Fully Setup Driver DVD into your optical drive and install the driver for better system performance.

You will see the following window after you insert the DVD



The setup guide will auto detect your motherboard and operating system.

**Note:** If this window didn't show up after you insert the Driver DVD, please use file browser to locate and execute the file **SETUP.EXE** under your optical drive.

#### A. Driver Installation

To install the driver, please click on the Driver icon. The setup guide will list the compatible driver for your motherboard and operating system. Click on each device driver to launch the installation program.

#### B. Software Installation

To install the software, please click on the Software icon. The setup guide will list the software available for your system, click on each software title to launch the installation program.

#### C. Manual

Aside from the paperback manual, we also provide manual in the Driver DVD. Click on the Manual icon to browse for available manual.

**Note:** You will need Acrobat Reader to open the manual file. Please download the latest version of Acrobat Reader software from <http://www.adobe.com/products/acrobat/readstep2.html>

## 6.2 EXTRA INFORMATION

### ***CPU Overheated***

If the system shutdown automatically after power on system for seconds, that means the CPU protection function has been activated.

When the CPU is over heated, the motherboard will shutdown automatically to avoid a damage of the CPU, and the system may not power on again.

In this case, please double check:

1. The CPU cooler surface is placed evenly with the CPU surface.
2. CPU fan is rotated normally.
3. CPU fan speed is fulfilling with the CPU speed.

After confirmed, please follow steps below to relief the CPU protection function.

1. Remove the power cord from power supply for seconds.
2. Wait for seconds.
3. Plug in the power cord and boot up the system.

Or you can:

1. Clear the CMOS data.  
(See "Close CMOS Header: JCMOS1" section)
2. Wait for seconds.
3. Power on the system again.

### 6.3 AMI BIOS POST CODE

Code	Description
10	PEI Core is started
11	Pre-memory CPU initialization is started
15	Pre-memory North Bridge initialization is started
19	Pre-memory South Bridge initialization is started
2B	Memory initialization. Serial Presence Detect (SPD) data reading
2C	Memory initialization. Memory presence detection
2D	Memory initialization. Programming memory timing information
2E	Memory initialization. Configuring memory
2F	Memory initialization (other).
31	Memory Installed
32	CPU post-memory initialization is started
33	CPU post-memory initialization. Cache initialization
34	CPU post-memory initialization. Application Processor(s) (AP) initialization
35	CPU post-memory initialization. Boot Strap Processor (BSP) selection
36	CPU post-memory initialization. System Management Mode (SMM) initialization
37	Post-Memory North Bridge initialization is started
3B	Post-Memory North Bridge initialization (North Bridge module specific)
4F	DXE IPL is started
60	DXE Core is started
F0	Recovery condition triggered by firmware (Auto recovery)
F1	Recovery condition triggered by user (Forced recovery)
F2	Recovery process started
F3	Recovery firmware image is found
F4	Recovery firmware image is loaded
E0	S3 Resume is started (S3 Resume PPI is called by the DXE IPL)
E1	S3 Boot Script execution
E2	Video repost
E3	OS S3 wake vector call
60	DXE Core is started
61	NVRAM initialization
62	Installation of the South Bridge Runtime Services
63	CPU DXE initialization is started
68	PCI host bridge initialization
69	North Bridge DXE initialization is started
6A	North Bridge DXE SMM initialization is started
70	South Bridge DXE initialization is started
71	South Bridge DXE SMM initialization is started
72	South Bridge devices initialization
78	South Bridge DXE Initialization (South Bridge module specific)
79	ACPI module initialization
90	Boot Device Selection (BDS) phase is started
91	Driver connecting is started
92	PCI Bus initialization is started
93	PCI Bus Hot Plug Controller Initialization
94	PCI Bus Enumeration
95	PCI Bus Request Resources
96	PCI Bus Assign Resources
97	Console Output devices connect
98	Console input devices connect

## Motherboard Manual

---

---

Code	Description
99	Super IO Initialization
9A	USB initialization is started
9B	USB Reset
9C	USB Detect
9D	USB Enable
A0	IDE initialization is started
A1	IDE Reset
A2	IDE Detect
A3	IDE Enable
A4	SCSI initialization is started
A5	SCSI Reset
A6	SCSI Detect
A7	SCSI Enable
A8	Setup Verifying Password
A9	Start of Setup
AB	Setup Input Wait
AD	Ready To Boot event
AE	Legacy Boot event
AF	Exit Boot Services event
B0	Runtime Set Virtual Address MAP Begin
B1	Runtime Set Virtual Address MAP End
B2	Legacy Option ROM Initialization
B3	System Reset
B4	USB hot plug
B5	PCI bus hot plug
B6	Clean-up of NVRAM
B7	Configuration Reset (reset of NVRAM settings)

## 6.4 TROUBLESHOOTING

Probable	Solution
<ol style="list-style-type: none"> <li>1. There is no power in the system. Power LED does not shine; the fan of the power supply does not work</li> <li>2. Indicator light on keyboard does not shine.</li> </ol>	<ol style="list-style-type: none"> <li>1. Make sure power cable is securely plugged in.</li> <li>2. Replace cable.</li> <li>3. Contact technical support.</li> </ol>
System is inoperative. Keyboard lights are on, power indicator lights are lit, and hard drives are running.	Using even pressure on both ends of the DIMM, press down firmly until the module snaps into place.
System does not boot from a hard disk drive, but can be booted from optical drive.	<ol style="list-style-type: none"> <li>1. Check cable running from disk to disk controller board. Make sure both ends are securely plugged in; check the drive type in the standard CMOS setup.</li> <li>2. Backing up the hard drive is extremely important. All hard disks are capable of breaking down at any time.</li> </ol>
System only boots from an optical drive. Hard disks can be read, applications can be used, but system fails to boot from a hard disk.	<ol style="list-style-type: none"> <li>1. Back up data and applications files.</li> <li>2. Reformat the hard drive. Re-install applications and data using backup disks.</li> </ol>
Screen message shows "Invalid Configuration" or "CMOS Failure."	Review system's equipment. Make sure correct information is in setup.
System cannot boot after user installs a second hard drive.	<ol style="list-style-type: none"> <li>1. Set master/slave jumpers correctly.</li> <li>2. Run SETUP program and select correct drive types. Call the drive manufacturers for compatibility with other drives.</li> </ol>

## APPENDIX: SPEC IN OTHER LANGUAGES

### GERMAN

<i>Spezifikationen</i>		
CPU	Socket 1155 Intel Core i7 / i5 / i3 / Pentium / Celeron Prozessoren (TDP: 95W)	Unterstützt Execute Disable Bit / Enhanced Intel SpeedStep® / Intel Architecture-64 / Extended Memory 64 Technology / Virtualization Technology / Hyper Threading
Chipsatz	Intel Z77	
Super E/A	IT8728F Bietet die häufig verwendeten alten Super E/A-Funktionen. Low Pin Count-Schnittstelle	Umgebungskontrolle, Hardware-Überwachung Lüfterdrehzahl-Controller/-Überwachung "Smart Guardian"-Funktion von ITE
Arbeitsspeicher	DDR3 DIMM-Steckplätze x 4 Max. 32GB Arbeitsspeicher Jeder DIMM unterstützt 512MB/ 1GB/2GB/4GB/8GB DDR3.	Dual-Kanal DDR3 Speichermodul Unterstützt DDR3 1066 / 1333 / 1600 Unterstützt DDR3 (OC) 1800/ 1866/ 2000/ 2133/ 2200/ 2400/ 2600 registrierte DIMMs. ECC DIMMs werden nicht unterstützt.
SATA 2 & 3	Integrierter Serial ATA-Controller	Datentransferrate bis zu 3.0Gb/s / 6.0Gb/s. Konform mit der SATA-Spezifikation Version 2.0 / 3.0 Unterstützt RAID 0,1,5,10, SRT
LAN	Realtek RTL 8111F	10 / 100 / 1000 Mb/s Auto-Negotiation Halb-/ Voll duplex-Funktion
HD Audio-Unterstützung	ALC898	Unterstützt High-Definition Audio 7.1-Kanal-Audioausgabe, Biostar Hi-Fi
USB3.0	Z77	Datenübertragungsraten bis zu 600 MB / s
Steckplätze	PCI Express Gen3 x16 Steckplatz x2 PCI Express Gen2 x16 Steckplatz(x4) x1 PCI Express Gen2 x 1-Steckplatz x3	
Onboard-Anschluss	SATA3-Anschluss x2 SATA2-Anschluss x4 Fronttafelanschluss x1 Front-Audioanschluss x1	Jeder Anschluss unterstützt 1 SATA3-Laufwerk Jeder Anschluss unterstützt 1 SATA2-Laufwerk Unterstützt die Fronttafel-funktionen Unterstützt die Fronttafel-Audioanschlussfunktion

<b>Spezifikationen</b>			
	CPU-Lüfter-Sockel	x1	CPU-Lüfterstromversorgungsanschluss (mit Smart Fan-Funktion)
	System-Lüfter-Sockel	x2	System-Lüfter-Stromversorgungsanschluss
	"CMOS löschen"-Sockel	x1	
	USB2.0-Anschluss	x2	Jeder Anschluss unterstützt 2 Fronttafel-USB2.0-Anschlüsse
	USB3.0-Anschluss	x1	Jeder Anschluss unterstützt 2 Fronttafel-USB3.0-Anschlüsse
	Verbraucher-IR Anschluss	x1	
	Serieller Anschluss	x1	
	S/PDIF Ausgangsanschluss	x1	Unterstützt die digitale Audioausgabefunktion
	Stromanschluss (24-polig)	x1	
	Stromanschluss (8-polig)	x1	
Rückseiten-E/A	PS/2-Tastatur/ Maus	x1	
	HDMI-Anschluss	x1	
	VGA-Anschluss	x1	
	DVI-Anschluss	x1	
	LAN-Anschluss	x1	
	USB2.0-Anschluss	x4	
	USB3.0-Anschluss	x2	
	Audioanschluss	x6	
Platinengröße	244 mm (B) X 305 mm (L)		ATX
OS-Unterstützung	Windows XP / Vista / 7/ 8		Biostar behält sich das Recht vor, ohne Ankündigung die Unterstützung für ein Betriebssystem hinzuzufügen oder zu entfernen.

**FRENCH**

SPEC		
UC	Socket 1155 Processeurs Intel Core i7 / i5 / i3 / Pentium / Celeron (TDP: 95W)	Prend en charge les technologies d'exécution de bit de désactivation / Intel SpeedStep® optimisée/ d'architecture Intel 64 / de mémoire étendue 64 / de virtualisation / Hyper Threading
Chipset	Intel Z77	
Super E/S	IT8728F Fournit la fonctionnalité de Super E/S patrimoniales la plus utilisée. Interface à faible compte de broches	Initiatives de contrôle environnementales, Moniteur de matériel Contrôleur /moniteur de vitesse de ventilateur Fonction "Gardien intelligent" de l'ITE
Mémoire principale	Fentes DDR3 DIMM x 4 Capacité mémoire maximale de 32 Go Chaque DIMM prend en charge des DDR3 de 512Mo/1Go/2Go/4Go/8Go	Module de mémoire DDR3 à mode à double voie Prend en charge la DDR3 1066 / 1333 / 1600 Prend en charge la DDR3 (OC) 1800/ 1866/ 2000/ 2133/ 2200/ 2400/ 2600 Les DIMM à registres et DIMM avec code correcteurs d'erreurs ne sont pas prises en charge
SATA 2 & 3	Contrôleur Serial ATA intégré :	Taux de transfert jusqu'à 3.0Go/s / 6.0Go/s. Conforme à la spécification SATA Version 2.0 / 3.0 Prise en charge RAID 0,1,5,10, SRT
LAN	Realtek RTL 8111F	10 / 100 / 1000 Mb/s négociation automatique Half / Full duplex capability
Prise en charge audio HD	ALC898	Prise en charge de l'audio haute définition Sortie audio à 7.1 voies, Biostar Hi-Fi
USB3.0	Z77	Taux de transfert de données jusqu'à 600 Mo / s
Fentes	Fente PCI Express Gen3 x16 x2 Fente PCI Express Gen2 x16(x4) x1 Fente PCI Express Gen2 x1 x3	
Connecteur embarqué	Connecteur SATA3 x2 Connecteur SATA2 x4 Connecteur du panneau avant x1 Connecteur Audio du panneau avant x1	Chaque connecteur prend en charge 1 périphérique SATA3 Chaque connecteur prend en charge 1 périphérique SATA2 Prend en charge les équipements du panneau avant Prend en charge la fonction audio du panneau avant



<i>SPEC</i>			
	Embase de ventilateur UC	x1	Alimentation électrique du ventilateur UC (avec fonction de ventilateur intelligent)
	Embase de ventilateur système	x2	Alimentation électrique du ventilateur système
	Embase d'effacement CMOS	x1	
	Connecteur USB2.0	x2	Chaque connecteur prend en charge 2 ports USB2.0 de panneau avant
	Connecteur USB3.0	x1	Chaque connecteur prend en charge 2 ports USB3.0 de panneau avant
	Connecteur de IR du consommateur	x1	
	Port série	x1	
	Connecteur de sortie S/PDIF	x1	Prend en charge la fonction de sortie audio numérique
	Connecteur d'alimentation (24 broches)	x1	
	Connecteur d'alimentation (8 broches)	x1	
E/S du panneau arrière	Clavier PS/2 Clavier/ Souris	x1	
	Port HDMI	x1	
	Port VGA	x1	
	Port DVI	x1	
	Port LAN	x1	
	Port USB2.0	x4	
	Port USB3.0	x2	
	Fiche audio	x6	
Dimensions de la carte	244 mm (l) X 305 mm (H)		ATX
Support SE	Windows XP / Vista / 7/ 8		Biostar se réserve le droit d'ajouter ou de supprimer le support de SE avec ou sans préavis

**ITALIAN**

<b>SPECIFICA</b>		
CPU	Socket 1155 Processore Intel Core i7 / i5 / i3 / Pentium / Celeron(TDP: 95W)	Supporto di Execute Disable Bit / Enhanced Intel SpeedStep® / Architettura Intel 64 / Tecnologia Extended Memory 64 / Tecnologia Virtualization / Hyper Threading
Chipset	Intel Z77	
Super I/O	IT8728F Fornisce le funzionalità legacy Super I/O usate più comunemente. Interfaccia LPC (Low Pin Count)	Funzioni di controllo dell'ambiente: Monitoraggio hardware Controller / Monitoraggio velocità ventolina Funzione "Smart Guardian" di ITE
Memoria principale	Alloggi DIMM DDR3 x 4 Capacità massima della memoria 32GB Ciascun DIMM supporta DDR3 512MB/1GB/2GB/4GB/8GB	Modulo di memoria DDR3 a canale doppio Supporto di DDR3 1066 / 1333 / 1600 Supporto di DDR3 (OC) 1800/ 1866/ 2000/ 2133/ 2200/ 2400/ 2600 DIMM registrati e DIMM ECC non sono supportati
SATA 2 & 3	Controller Serial ATA integrato	Velocità di trasferimento dei dati fino a 3.0Gb/s / 6.0Gb/s. Compatibile specifiche SATA Versione 2.0/3.0 Supporto RAID 0,1,5,10, SRT
LAN	Realtek RTL 8111F	Negoziazione automatica 10 / 100 / 1000 Mb/s Capacità Half / Full Duplex
Supporto audio HD	ALC898	Supporto audio High-Definition (HD) Uscita audio 7.1 canali, Biostar Hi-Fi
USB3.0	Z77	Velocità di trasferimento dati fino a 600 MB / s
Alloggi	Alloggio PCI Express Gen3 x16 x2 Alloggio PCI Express Gen2 x16(x4) x1 Alloggio PCI Express Gen2 x1 x3	
Connettori su scheda	Connettore SATA3 x2 Connettore SATA2 x4 Connettore pannello frontale x1 Connettore audio frontale x1 Collettore ventolina CPU x1 Collettore ventolina sistema x2	Ciascun connettore supporta 1 unità SATA3 Ciascun connettore supporta 1 unità SATA2 Supporta i servizi del pannello frontale Supporta la funzione audio pannello frontale Alimentazione ventolina CPU (con funzione Smart Fan) Alimentazione ventolina di sistema

<b>SPECIFICA</b>			
	Collettore cancellazione CMOS	x1	
	Connettore USB2.0	x2	Ciascun connettore supporta 2 porte USB2.0 pannello frontale
	Connettore USB3.0	x1	Ciascun connettore supporta 2 porte USB3.0 pannello frontale
	Connettore IR del consumatore	x1	
	Porta seriale	x1	
	Connettore output S/PDIF	x1	Supporta la funzione d'output audio digitale
	Connettore alimentazione (24 pin)	x1	
	Connettore alimentazione (8 pin)	x1	
I/O pannello posteriore	Tastiera/ Mouse PS/2	x1	
	Porta HDMI	x1	
	Porta VGA	x1	
	Porta DVI	x1	
	Porta LAN	x1	
	Porta USB2.0	x4	
	Porta USB3.0	x2	
	Connettore audio	x6	
Dimensioni scheda	244 mm (larghezza) x 305 mm (altezza)		ATX
Sistemi operativi supportati	Windows XP / Vista / 7/ 8		Biostar si riserva il diritto di aggiungere o rimuovere il supporto di qualsiasi sistema operativo senza preavviso.

**SPANISH**

<b>Especificación</b>		
CPU	Socket 1155 Procesador Intel Core i7 / i5 / i3 / Pentium / Celeron (TDP: 95W)	Admite Bit de deshabilitación de ejecución / Intel SpeedStep® Mejorado / Intel Architecture-64 / Tecnología Extended Memory 64 / Tecnología de virtualización / Hyper Threading
Conjunto de chips	Intel Z77	
Súper E/S	IT8728F Le ofrece las funcionalidades heredadas de uso más común Súper E/S. Interfaz de cuenta Low Pin	Iniciativas de control de entorno, Monitor hardware Controlador/monitor de velocidad de ventilador Función "Guardia inteligente" de ITE
Memoria principal	Ranuras DIMM DDR3 x 4 Capacidad máxima de memoria de 32GB Cada DIMM admite DDR de 512MB/1GB/2GB/4GB/8GB	Módulo de memoria DDR3 de canal Doble Admite DDR3 de 1066 / 1333 / 1600 Admite DDR3 de (OC) 1800/ 1866/ 2000/ 2133/ 2200/ 2400/ 2600 No admite DIMM registrados o DIMM compatibles con ECC
SATA 2 & 3	Controlador ATA Serie Integrado	Tasas de transferencia de hasta 3.0 Gb/s / 6.0 Gb/s. Compatible con la versión SATA 2.0 / 3.0. Admite RAID 0,1,5,10, SRT
Red Local	Realtek RTL 8111F	Negociación de 10 / 100 / 1000 Mb/s Funciones Half / Full dúplex
Soporte de sonido HD	ALC898	Soporte de sonido de Alta Definición Salida de sonido de 7.1 canales, Biostar Hi-Fi
USB3.0	Z77	Tasas de transferencia de datos hasta 600 MB / s
Ranuras	Ranura PCI Express Gen3 x16 X2 Ranura PCI Express Gen2 x16(x4) X1 Ranura PCI Express Gen2 x 1 X3	
Conectores en placa	Conector SATA3 X2 Conector SATA2 X4 Conector de panel frontal X1 Conector de sonido frontal X1 Cabecera de ventilador de CPU X1 Cabecera de ventilador de sistema X2	Cada conector soporta 1 dispositivos SATA3 Cada conector soporta 1 dispositivos SATA2 Soporta instalaciones en el panel frontal Soporta funciones de sonido en el panel frontal Fuente de alimentación de ventilador de CPU (con función Smart Fan) Fuente de alimentación de ventilador de sistema

<b>Especificación</b>			
	Cabecera de borrado de CMOS	X1	
	Conector USB2.0	X2	Cada conector soporta 2 puertos USB2.0 frontales
	Conector USB3.0	X1	Cada conector soporta 2 puertos USB3.0 frontales
	Conector de IR del consumidor	X1	
	Puerto serie	X1	
	Conector de salida S/PDIF	X1	Soporta función de salida de sonido digital
	Conector de alimentación (24 patillas)	X1	
	Conector de alimentación (8 patillas)	X1	
Panel trasero de E/S	Teclado/ Ratón PS/2	X1	
	Puerto HDMI	x1	
	Puerto VGA	X1	
	Puerto DVI	X1	
	Puerto de red local	X1	
	Puerto USB2.0	X4	
	Puerto USB3.0	X2	
	Conector de sonido	X6	
Tamaño de la placa	244 mm. (A) X 305 Mm. (H)		ATX
Soporte de sistema operativo	Windows XP / Vista / 7/ 8		Biostar se reserva el derecho de añadir o retirar el soporte de cualquier SO con o sin aviso previo.

**PORTUGUESE**

<b>ESPECIFICAÇÕES</b>		
CPU	Socket 1155 Processador Intel Core i7 / i5 / i3 / Pentium / Celeron (TDP: 95W)	Suporta as tecnologias Execute Disable Bit / Enhanced Intel SpeedStep® / Intel Architecture -64 / Extended Memory 64 / Virtualization / Hyper Threading
Chipset	Intel Z77	
Especificação do Super I/O	IT8728F Proporciona as funcionalidades mais utilizadas em termos da especificação Super I/O. Interface LPC (Low Pin Count).	Iniciativas para controlo do ambiente Monitorização do hardware Controlador/Monitor da velocidade da ventoinha Função "Smart Guardian" da ITE
Memória principal	Ranuras DIMM DDR3 x 4 Capacidade máxima de memória: 32 GB Cada módulo DIMM suporta uma memória DDR3 de 512MB/ 1GB/2GB/4GB/8GB	Módulo de memória DDR3 de canal duplo Suporta módulos DDR3 1066 / 1333 / 1600 Suporta módulos DDR3 (OC) 1800/ 1866/ 2000/ 2133/ 2200/ 2400/ 2600 Os módulos DIMM registados e os DIMM ECC não são suportados
SATA 2 & 3	Controlador Serial ATA integrado	Velocidades de transmissão de dados até 3.0 Gb/s / 6.0 Gb/s. Compatibilidade com a especificação SATA versão 2.0 / 3.0. Suporta as funções RAID 0,1,5,10, SRT
LAN	Realtek RTL 8111F	Auto negociação de 10 / 100 / 1000 Mb/s Capacidade semi/full-duplex
Suporte para áudio de alta definição	ALC898	Suporta a especificação High-Definition Audio Saída de áudio de 7.1 canais, Biostar Hi-Fi
USB3.0	Z77	Taxas de transferência de dados até 600 MB / s
Ranuras	Ranura PCI Express Gen3 x16 x2 Ranura PCI Express Gen2 x16(x4) x1 Ranura PCI Express Gen2 x 1 x3	
Conectores na placa	Conector SATA3 x2 Conector SATA2 x4 Conector do painel frontal x1 Conector de áudio frontal x1	Cada conector suporta 1 dispositivo SATA3 Cada conector suporta 1 dispositivo SATA2 Para suporte de várias funções no painel frontal Suporta a função de áudio no painel frontal

<b>ESPECIFICAÇÕES</b>			
	Conector da ventoinha da CPU	x1	Alimentação da ventoinha da CPU (com a função Smart Fan)
	Conector da ventoinha do sistema	x2	Alimentação da ventoinha do sistema
	Conector para limpeza do CMOS	x1	
	Conector USB2.0	x2	Cada conector suporta 2 portas USB2.0 no painel frontal
	Conector USB3.0	x1	Cada conector suporta 2 portas USB3.0 no painel frontal
	Conector de IR do consumidor	x1	
	Porta série	x1	
	Conector de saída S/PDIF	x1	Suporta a saída de áudio digital
	Conector de alimentação (24 pinos)	x1	
	Conector de alimentação (8 pinos)	x1	
Entradas/Saídas no painel traseiro	Tedado/ Mouse PS/2	x1	
	Porta HDMI	x1	
	Porta VGA	x1	
	Porta DVI	x1	
	Porta LAN	x1	
	Porta USB2.0	x4	
	Porta USB3.0	x2	
	Tomada de áudio	x6	
Tamanho da placa	244 mm (L) X 305 mm (A)		ATX
Sistemas operativos suportados	Windows XP / Vista / 7 / 8		A Biostar reserva-se o direito de adicionar ou remover suporte para qualquer sistema operativo com ou sem aviso prévio.

**POLISH**

SPEC		
Procesor	Socket 1155 Procesor Intel Core i7 / i5 / i3 / Pentium / Celeron (TDP: 95W)	Obsługa Execute Disable Bit / Enhanced Intel SpeedStep® / Intel Architecture-64 / Extended Memory 64 Technology / Virtualization Technology / Hyper Threading
Chipset	Intel Z77	
Pamięć główna	Gniazda DDR3 DIMM x 4 Maks. wielkość pamięci 32GB Każde gniazdo DIMM obsługuje moduły 512MB/1GB/2GB/4GB/8GB DDR3	Moduł pamięci DDR3 z trybem podwójnego kanału Obsługa DDR3 1066 / 1333 / 1600 Obsługa DDR3 (OC) 1800/ 1866/ 2000/ 2133/ 2200/ 2400/ 2600 Brak obsługi Registered DIMM oraz ECC DIMM
Super I/O	IT8728F Zapewnia najbardziej powszechne funkcje Super I/O. Interfejs Low Pin Count	Funkcje kontroli warunków pracy, Monitor H/W Kontroler/Monitor prędkości wentylatora Funkcja ITE "Smart Guardian"
SATA 2 & 3	Zintegrowany kontroler Serial ATA	Transfer danych do 3.0 Gb/s / 6.0 Gb/s. Zgodność ze specyfikacją SATA w wersji 2.0 / 3.0. Obsługa RAID 0,1,5,10, SRT
LAN	Realtek RTL 8111F	10 / 100 / 1000 Mb/s z automatyczną negocjacją szybkości Działanie w trybie połowicznego / pełnego duplexu
Obsługa audio HD	ALC898	Obsługa High-Definition Audio 7.1 kanałowe wyjście audio, Biostar Hi-Fi
USB3.0	Z77	Cena transferu danych do 600 MB / s
Gniazda	Gniazdo PCI Express Gen3 x16 x2 Gniazdo PCI Express Gen2 x16(x4) x1 Gniazdo PCI Express Gen2 x 1 x3	
Złącza wbudowane	Złącze SATA3 x2 Złącze SATA2 x4 Złącze panela przedniego x1 Przednie złącze audio x1 Złącze główkowe wentylatora procesora x1 Złącze główkowe wentylatora systemowego x2	Każde złącze obsługuje 1 urządzenie SATA3 Każde złącze obsługuje 1 urządzenie SATA2 Obsługa elementów panela przedniego Obsługa funkcji audio na panelu przednim Zasilanie wentylatora procesora (z funkcją Smart Fan) Zasilanie wentylatora systemowego



SPEC			
	Złącze główkowe kasowania CMOS	x1	
	Złącze USB2.0	x2	Każde złącze obsługuje 2 porty USB2.0 na panelu przednim
	Złącze USB3.0	x1	Każde złącze obsługuje 2 porty USB3.0 na panelu przednim
	Złącze Konsument IR	x1	
	Port szeregowy	x1	
	Złącze wyjścia S/PDIF	x1	Obsługa funkcji cyfrowego wyjścia audio
	Złącze zasilania (24 pinowe)	x1	
	Złącze zasilania (8 pinowe)	x1	
Back Panel	Klawiatura/ Myszka PS/2	x1	
I/O	Port HDMI	x1	
	Port VGA	x1	
	Port DVI	x1	
	Port LAN	x1	
	Port USB2.0	x4	
	Port USB3.0	x2	
	Gniazdo audio	x6	
Wymiary płyty	244 mm (S) X 305 mm (W)		ATX
Obsługa systemu operacyjnego	Windows XP / Vista / 7/ 8		Biostar zastrzega sobie prawo dodawania lub odwoływania obsługi dowolnego systemu operacyjnego bez powiadomienia.

**RUSSIAN**

<b>СПЕЦ</b>		
CPU (центральный процессор)	Socket 1155 Процессор Intel Core i7 / i5 / i3 / Pentium / Celeron (TDP: 95W)	Поддержка технологий Execute Disable Bit / Enhanced Intel SpeedStep® / Intel Architecture-64 / Extended Memory 64 Technology / технологии виртуализация / Hyper Threading
Набор микросхем	Intel Z77	
Основная память	Слоты DDR3 DIMM x 4 Максимальная ёмкость памяти 32 ГБ Каждый модуль DIMM поддерживает 512МБ/1ГБ/2ГБ/4ГБ/8 ГБ DDR3	Модуль памяти с двухканальным режимом DDR3 Поддержка DDR3 1066 / 1333 / 1600 Поддержка DDR3 (OC) 1800/ 1866/ 2000/ 2133/ 2200/ 2400/ 2600 Не поддерживает зарегистрированные модули DIMM and ECC DIMM
Super I/O	IT8728F Обеспечивает наиболее используемые действующие функциональные возможности Super I/O. Интерфейс с низким количеством выводов	Инициативы по охране окружающей среды, Аппаратный монитор Регулятор скорости вентилятора/ монитор Функция ITE "Smart Guardian" (Интеллектуальная защита)
SATA 2 & 3	Встроенное последовательное устройство управления ATA	скорость передачи данных до 3.0 гигабит/с / 6.0 гигабит/с. Соответствие спецификации SATA версия 2.0/3.0 Поддержка RAID 0,1,5,10, SRT
Локальная сеть	Realtek RTL 8111F	Автоматическое согласование 10 / 100 / 1000 Мб/с Частичная / полная дуплексная способность
Звуковая поддержка жесткого диска	ALC898	Звуковая поддержка High-Definition 7.1канальный звуковой выход, Biostar Hi-Fi
USB3.0	Z77	скорости передачи данных до 600 МБ / с
Слоты	Слот PCI Express Gen3 x16 x2 Слот PCI Express Gen2 x16(x4) x1 Слот PCI Express Gen2 x 1 x3	
Встроенный разъём	Разъём SATA3 x2 Разъём SATA2 x4 Разъём на лицевой панели x1 Входной звуковой разъём x1	Каждый разъём поддерживает 1 устройство SATA3 Каждый разъём поддерживает 1 устройство SATA2 Поддержка устройств на лицевой панели Поддержка звуковых функций на лицевой панели

СПЕЦ		
	Контактирующее приспособление вентилятора центрального процессора x1	Источник питания для вентилятора центрального процессора (с функцией интеллектуального вентилятора)
	Контактирующее приспособление вентилятора системы x2	Источник питания для вентилятора системы
	Открытое контактирующее приспособление CMOS x1	
	USB2.0-разъём x2	Каждый разъём поддерживает 2 USB2.0-порта на лицевой панели
	USB3.0-разъём x1	Каждый разъём поддерживает 2 USB3.0-порта на лицевой панели
	Разъём едока ИКЫЙ x1	
	Последовательный порт x1	
	Разъём вывода для S/PDIF x1	Поддержка вывода цифровой звуковой функции
	Разъем питания (24 вывод) x1	
	Разъем питания (8 вывод) x1	
Задняя панель средств ввода-вывода	клавиатура/ мышь PS/2 x1 Порт HDMI x1 Порт VGA x1 Порт DVI x1 Порт LAN x1 USB2.0-порт x4 USB3.0-порт x2 Гнездо для подключения наушников x6	
Размер панели	244 мм (Ш) X 305 мм (В)	ATX
Поддержка OS	Windows XP / Vista / 7/ 8	Biostar сохраняет за собой право добавлять или удалять средства обеспечения для OS с или без предварительного уведомления.

## ARABIC

المواصفات		
Execute Disable Bit / Enhanced Intel SpeedStep® / Intel Architecture-64 / Extended Memory 64 Technology / Virtualization Technology / Hyper Threading	Socket 1155 Intel Core i7 / i5 / i3 / Pentium / Celeron (TDP: 95W) يتردد يصل إلى	وحدة المعالجة المركزية
	Intel Z77	مجموعة الشرائح
عدد 4 قناة DDR3 DIMM سعة ذاكرة قصوى 32 جيجابايت ميجابايت و1/512/1 سعة DDR3 تدعم ذاكرة من نوع DIMM تدعم كل قناة و2/4/8 جيجابايت	مزدوجة القناة DDR3 وحدة ذاكرة سعات DDR3 1600/1333/1066 تدعم الذاكرة من نوع ميجابايت 1800/1866/ (OC) سعات DDR3 نوع من الذاكرة تدعم بايت ميجا 2000/2133/2200/2400/2600 ECC وتلك التي لا تتوافق مع DIMM لا تدعم رقائق الذاكرة	الذاكرة الرئيسية
وسائل التحكم في البيئة: مراقب لمعرفة حالة الأجهزة مراقب في سرعة المروحة ITE من "Smart Guardian" وظيفة	IT8728F الأكثر استخداماً Super I/O يوفر وظيفة Low Pin Count Interface تدعم تقنية	Super I/O
ثنائية/جيجابت 6.0 / ثنائية/جيجابت 3.0 إلى تصل بسرعات البيانات نقل 3.0 / 2.0 الإصدار SATA مطابقة لمواصفات RAID 0,1,5,10, SRT تدعم تقنية	متكامل Serial ATA SATA 2 & 3	SATA 2 & 3
تقويض تلقائي 100/10 ميجابايت / ثنائية و1 جيجابايت/ثنائية إمكانية النقل المزدوج الكامل/القصفي	Realtek RTL 8111F	شبكة داخلية
تدعم تقنية الصوت عالي التعريف من 7.1, Biostar Hi-Fi, قوات لخرج الصوت	ALC898	دعم الصوت عالي التعريف
ثنائية / بيت ميغا 600 إلى تصل بيانات نقل معدلات	Z77	USB3.0
	عدد 2 عدد 1 عدد 3	قناة PCI Express x16 Gen2 قناة PCI Express (x4)x16 Gen2 قناة PCI Express Gen2 x 1
يدعم كل منفذ واحد من أجهزة SATA3 يدعم كل منفذ واحد من أجهزة SATA2 يدعم تجهيزات اللوحة الأمامية يدعم وظيفة الصوت باللوحة الأمامية توصيل الطاقة لمروحة وحدة المعالجة مع وظيفة Smart Fan توصيل الطاقة لمروحة النظام	عدد 2 عدد 4 عدد 1 عدد 1 عدد 1 عدد 2	منفذ SATA3 على سطح اللوحة منفذ SATA2 منفذ اللوحة الأمامية منفذ الصوت الأمامي وصلة مروحة وحدة المعالجة المركزية وصلة مروحة النظام

## Hi-Fi Z77X

المواصفات		
	عدد 1	وصلة مسح CMOS
يدعم كل منفذ قحطي USB2.0 باللوحة الأممية	عدد 2	منفذ USB2.0
يدعم كل منفذ قحطي USB3.0 باللوحة الأممية	عدد 1	منفذ USB3.0
	عدد 1	منفذ مستهلكة تحت الأحمر
	عدد 1	منفذ تسلسلي
يدعم وظيفة خرج الصوت الرقمي	عدد 1	منفذ خرج S/PDIF
	عدد 1	منفذ توصيل الطاقة (24دبوس)
	عدد 1	منفذ توصيل الطاقة (8دبابيس)
	عدد 1	لوحة المفاتيح للكمبيوتر/الفايرة PS/2
	عدد 1	منفذ HDMI
	عدد 1	منفذ VGA
	عدد 1	منفذ DVI
	عدد 1	منفذ شبكة اتصال محلية
	عدد 4	منفذ USB2.0
	عدد 2	منفذ USB3.0
	عدد 6	مقيس صوت
	ATX	حجم اللوحة
		305 مم (عرض) X 244 مم (ارتفاع)
يحققها في اضافة أو ازالة الدعم لأي نظام تشغيل بلانطر أو Biostar تحتفظ بدون إخطار .	Windows XP / Vista / 7/ 8	دعم أنظمة التشغيل

## JAPANESE

仕様		
CPU	Socket 1155 Intel Core i7 / i5 / i3 / Pentium / Celeron プロセッサ (TDP: 95W)	Execute Disable Bit / Enhanced Intel SpeedStep® / Intel Architecture-64 / Extended Memory 64 Technology / Virtualization Technology / Hyper Threadingをサポートします
チップセット	Intel Z77	
メインメモリ	DDR3 DIMMスロット x 4 最大メモリ容量32GB 各DIMMは 512MB/1GB/2GB/4GB/8GB DDR3をサポート	デュアル チャンネルモードDDR3メモリモジュール DDR3 1066 / 1333 / 1600 をサポート DDR3 (OC) 1800/ 1866/ 2000/ 2133/ 2200/ 2400/ 2600をサポート 登録済みDIMMとECC DIMMはサポートされません
Super I/O	IT8728F もともと一般に使用されるレガシーSuper I/O機能を採用しています。 低ピンカウントインターフェイス	環境コントロールイニシアチブ、 H/Wモニター ファン速度コントローラ/ モニター ITEの「スマートガーディアン」機能
SATA 2 & 3	統合シリアルATAコントローラ	最高3.0 Gb/秒 / 6.0 Gb/秒のデータ転送速度 SATAバージョン2.0 / 3.0仕様に準拠。 RAID 0,1,5,10, SRT のサポート
LAN	Realtek RTL 8111F	10 / 100 / 1000 Mb/秒のオートネゴシエーション 半/全二重機能
HDオーディオのサポート	ALC898	ハイデフィニションオーディオのサポート 7.1 チャンネルオーディオアウト, Biostar Hi-Fi
USB3.0	Z77	データ転送速度最大600 MB /秒の
スロット	PCI Express Gen3 x16スロット x2 PCI Express Gen2 x16スロット(x4) x1 PCI Express Gen2 x 1スロット x3	
オンボードコネクタ	SATA3コネクタ x2 SATA2コネクタ x4 フロントパネルコネクタ x1 フロントオーディオコネクタ x1 CPUファンヘッダ x1 システムファンヘッダ x2 CMOSクリアヘッダ x1	各コネクタは1つのSATA3デバイスをサポートします 各コネクタは1つのSATA2デバイスをサポートします フロントパネル機能をサポートします フロントパネルオーディオ機能をサポートします CPUファン電源装置(スマートファン機能を搭載) システムファン電源装置

## Hi-Fi Z77X

仕様			
	USB2.0コネクタ	x2	各コネクタは2つのフロントパネルUSB2.0ポートをサポートします 各コネクタは2つのフロントパネルUSB3.0ポートをサポートします デジタルオーディオアウト機能をサポートします
	USB3.0コネクタ	x1	
	消費者IRコネクタ	x1	
	シリアルポート	x1	
	S/PDIFアウトコネクタ	x1	
	電源コネクタ(24ピン)	x1	
	電源コネクタ(8ピン)	x1	
背面パネル I/O	PS/2 キーボード/マウス	x1	
	HDMIポート	x1	
	VGAポート	x1	
	DVI-Dポート	x1	
	LANポート	x1	
	オーディオジャック	x6	
ボードサイズ	244 mm (幅) X 305 mm (高さ)		ATX
OSサポート	Windows XP / Vista / 7 / 8		Biostarは事前のサポートなしにOSサポートを追加または削除する権利を留保します。

2012/08/15