

***USER'S MANUAL***  
***Of***  
***AMD 690G/690V CHIPSET***  
***&***  
***AMD SB600 Chipset Based***  
***M/B for Socket AM2 64-bit Dual Core***  
***AMD Processor***

***No. G03-M2A692-F***

***Rev:3.0***

***Release date: May 2007***

**Trademark:**

\* Specifications and Information contained in this documentation are furnished for information use only, and are subject to change at any time without notice, and should not be construed as a commitment by manufacturer.

---

---

# TABLE OF CONTENT

---

---

<b>CHAPTER 1 INTRODUCTION OF AMD 690G/690V MOTHERBOARD SERIES</b>	
1-1 FEATURES OF MOTHERBOARD .....	1
1-1.1 SPECIAL FEATURES OF MOTHERBOARD.....	2
1-2 SPECIFICATION.....	3
1-3 ITEM CHECKLIST .....	4
1-4 LAYOUT DIAGRAM & JUMPER SETTING .....	4
<b>CHAPTER 2 HARDWARE INSTALLATION</b>	
2-1 INSTALL SOCKET AM2 SUPPORTED AMD PROCESSOR.....	5
2-2 INSTALL MEMORY .....	5
2-3 EXPANSION CARDS .....	6
<b>CHAPTER 3 CONNCTORS, HEADERS &amp; JUMPERS SETTING</b>	
3-1 CONNECTORS .....	7
3-2 HEADERS.....	11
<b>CHAPTER 4 USEFUL HELP</b>	
4-1 HOW TO UPDATE BIOS.....	13
4-2 TROUBLE SHOOTING .....	13
4-3 THE INTRODUCTION OF BIOS BACK FUNCTION.....	14

## Environmental Protection Announcement

Do not dispose this electronic device into the trash while discarding. To minimize pollution and ensure environment protection of mother earth, please recycle.



---

---

# Chapter 1

## Introduction of AMD 690G/690V Motherboard Series

### 1-1 Features of motherboard

The AMD 690G/690V Series motherboards are based on the latest AMD 690G/690V Chipset and SB600 chipset which supports the new generation innovative 64-bit AMD Socket AM2 dual core multi-tasking Socket AM2 Athlon64 X2 processors. With an integrated low-latency high-bandwidth DDR2 memory controller and the highly-scalable Hyper Transport technology-based system bus which is up to 1000 MHz, AMD 690G/690V Platform Processor Chipset motherboard series deliver the outstanding system performance and professional desktop platform solution with the advantages of new generation 64-bit AMD Socket AM2 Athlon64 X2 processors and the fully compatibility of the next generation operation system.

The AMD 690G/690V Series motherboards support new generation Socket AM2 processors with an integrated DDR2 memory controller which provides with 266MHz / 333MHz / 400MHz memory clock frequency for Dual channel DDR2 533 / DDR2 667 / DDR2 800 (Sempron processor of AM2 socket only supports up to DDR2 667) DDR2 Module up to 8.0GB. The whole motherboard series are embedded with SB600 chipset that provides ULTRA ATA 133 connectors and Serial ATA2 with RAID 0, 1 and RAID 10 functions which support up to two IDE devices and four Serial ATA2 devices to accelerate hard disk drives and guarantee the data security without failure in advanced computing performance.

The AMD 690V Chipset incorporates ATI Radeon X1200 Graphics with a core frequency of 400 MHz and 2 shader pipeline featured with DirectX 9.0 compliant 2D/3D graphics processor, Maximum DAC frequency of 400 MHz Resolution up to 2560x1600 (Under condition), refresh rate up to 85MHz delivering incredible graphics and blistering performance. Besides, the AMD 690G Series motherboards integrated ATI Radeon X1250 Graphics support ATI innovated AVIVO Technology and Multiple Display configurations: CRT+ DVI-D or HDMI on rear panel and give you the best performance in game experience. AMD™ 690G/690V chipset provides incredible flexibility and unlimited upgrade potential as it supports all Radeon® PCI – E graphics cards on a system configured for either single GPU or next generation multimedia operation. Designed with ATI's unique architecture to optimize speed and stability, this solution is perfect for overclocking – without the need of additional cooling systems.

The 690V /690G series motherboards provide optional 10/100 or 10/100/1000 LAN functions with Realtek RTL8101E-GR PCI-E 10/100 LAN or RTL8111B-GR PCI-E Gigabit LAN which supports 10/100Mbps or 10/100/1000 Mbps data transfer rate. And the embedded optional Azalia 8-channel Audio CODEC is fully compatible with Sound Blaster Pro® standards that offer you with the home cinema quality and satisfying software compatibility. The optional embedded 6-channel AC' 97 Audio CODEC is fully compatible with Sound Blaster Pro® standard.

The motherboards offer one PCI-Express x16 graphics slot of 4Gbyte/sec data transfer rate at each relative direction which gets 3.5 times of bandwidth more than AGP 8X and it's up to a peak concurrent bandwidth of 8Gbyte/sec at full speed to guarantee the ultimate GPU

---

---

computing performance. Two 32-bit PCI slots guarantee the rich connectivity for the I/O of peripherals; the motherboards are designed of tackling the profuse multimedia requirements nowadays.

Embedded USB controller as well as capability of expanding to 8 of USB 2.0 functional ports delivering 480Mb/s bandwidth and rich connectivity, these motherboards meet the future USB demands which are also equipped with hardware monitor function on system to monitor and protect your system and maintain your non-stop business computing.

Some special features---**CPU Thermal Throttling/ CPU Vcore 7-shift / CPU Smart Fan / DeBug Port / BIOS BACK Function** in this motherboard are designed for power user to use the over-clocking function in more flexible ways. But please be caution that the over-clocking maybe cause the fails in system reliabilities. This motherboard provides the guaranteed performance and meets the demands of the next generation computing. But if you insist to gain more system performance with variety possibilities of the components you choose, please be careful and make sure to read the detailed descriptions of these value added product features, please get them in the coming section.

## 1-1.1 Special Features of Motherboard

**Optional Debug Port** --- ( The Professional Hardware Diagnosis System )

Being bugged of abnormal system failure through the tossed and turned nights no more, the embedded Hardware Debug Port offers you the real-time visual system healthy for the demanding usage of computing. No more bugging by unknown system failure and no more time wasted in the first moment of 24-hour nonstop ping business computing, the embedded Debug Port will turn you into a well training hardware professional with the seeing system situation. (The Post Code please refer to the Website: <http://download.jetway.com.tw/download/DEBUG-PORT-LIST.pdf> )

**CPU Smart Fan**---( The Noise Management System ( Only support 4-pin CPU cooler ) )

It's never been a good idea to gain the performance of your system by sacrificing its acoustics. CPU Smart Fan Noise Management System is the answer to control the noise level needed for now-a-day's high performance computing system. The system will automatically increase the fan speed when CPU operating loading is high, after the CPU is in normal operating condition, the system will low down the fan speed for the silent operating environment. The system can provide the much longer life cycle for both CPU and the system fans for game use and business requirements.

**CPU Vcore 7-Shift**--- (Shift to Higher Performance)

The CPU voltage can be adjusted up by 13 steps for the precisely over-clocking of extra demanding computing performance.

**Optional BIOS BACK Function** --- ( The BIOS Backup and Recovery Function )

With the new support for the Serial Peripheral Interface, the whole motherboard series are embedded with the new storage of the extra bin file for BIOS recovery. When unexpected error occurs, even the BIOS crashes down, you can restore your BIOS with just simply clicking to restart your system. The backup bin file will recover original BIOS within a few minutes.

**CPU Thermal Throttling Technology**---(The CPU Overheat Protection Technology)

To prevent the increasing heat from damage of CPU or accidental shutdown while at high workload, the CPU Thermal Throttling Technology will force CPU to enter partially idle mode from 87.5% to 12.5% according to preset CPU operating temperature in BIOS (from 40°C to 90°C). When the system senses the CPU operating temperature reaching the preset value, the CPU operating bandwidth will be decreased to the preset idle percentage to cool down the processor. When at throttling mode the beeper sound can be optionally selected to indicate it is in working.

## 1-2 Specification

Spec	Description
<b>Design</b>	* Micro ATX form factor 4 layers PCB size: 24.4 cm*21.0cm
<b>Chipset</b>	* AMD 690G/690V Chipset and AMD SB600 Chipset
<b>CPU Socket AM2</b>	* Support 64bit AMD AM2 940-Pin package utilizes Flip-Chip Pin Grid Array package compatible processor * Support for HTT 1GHz AMD Athlon 64 X2 processor and Athlon 64, and HTT 800MHz Sempron Processors
<b>Memory Socket</b>	* 240-pin DDR2 Module socket x 4 * Support 4 pcs DDR2 533 / DDR2 667 / DDR2 800 Modules Expandable to 8.0 GB
<b>Expansion Slot</b>	* PCI-Express x16 slot 1pcs delivers up to 8 GB/s of concurrent bandwidth. * 32-bit PCI slot x 2 pcs
<b>Integrate IDE and Serial ATA2 RAID</b>	* One IDE controllers support PCI Bus Mastering, ATA PIO / DMA and the ULTRA DMA 33/66/100/133 functions that deliver the data transfer rate up to 133 MB/s. * Four Serial ATA2 ports provide 300 MB/sec data transfer rate with RAID 0, 1, 10 functions.
<b>Integrated VGA</b>	* Integrated with ATI Radeon X1200 / X1250 Graphic * a core frequency of 400 MHz and 4 shader pipeline * DirectX 9.0 compliant 2D/3D graphics processor * supported ATI innovated AVIVO Technology and Multiple Display configurations (only for 690G series)
<b>LAN (Option)</b>	* Integrated Realtek RTL8101E-GR PCI-E 10/100 LAN chip or RTL8111B-GR PCI-E gigabit LAN chip * Supports Fast Ethernet LAN function provide 10/100 or 10/100/1000 Mb /s data transfer rate
<b>6-CH Audio (option)</b>	* Realtek ALC861-VS AC97' 6-channel Audio Codec integrated * Audio driver and utility included
<b>8-CH Audio (option)</b>	* Realtek ALC880E Azalia HD 8-channel Audio Codec integrated * Support 8-channel 3D surround & Positioning Audio * Audio driver and utility included
<b>BIOS</b>	* Award 4MB Flash ROM
<b>Multi I/O</b>	* PS/2 keyboard and PS/2 mouse connectors * Floppy disk drive connector x1 * 1* Parallel port of 25-pin Block / 1 * Serial port of 9-pin Block * 1 * VGA port / 1 * TV-OUT header * 1 * HDMI port (optional) /1 * DVI port (optional) * 1* SPDIF header (optional) * USB2.0 port x 4 and headers x 4 (connecting optional cable) * Audio connector (Line-in, Line-out, MIC/optional 8CH Audio)

## 1-3 Item Checklist

- ☑ AMD 690G/690V Platform Processor Chipset based motherboard
- ☑ Cable for IDE
- ☑ CD for motherboard utilities
- ☑ Cable for Serial ATA IDE Port
- ☑ AMD 690G/690V Platform Processor Chipset motherboard User's Manual

## 1-4 Layout Diagram & Jumper Setting

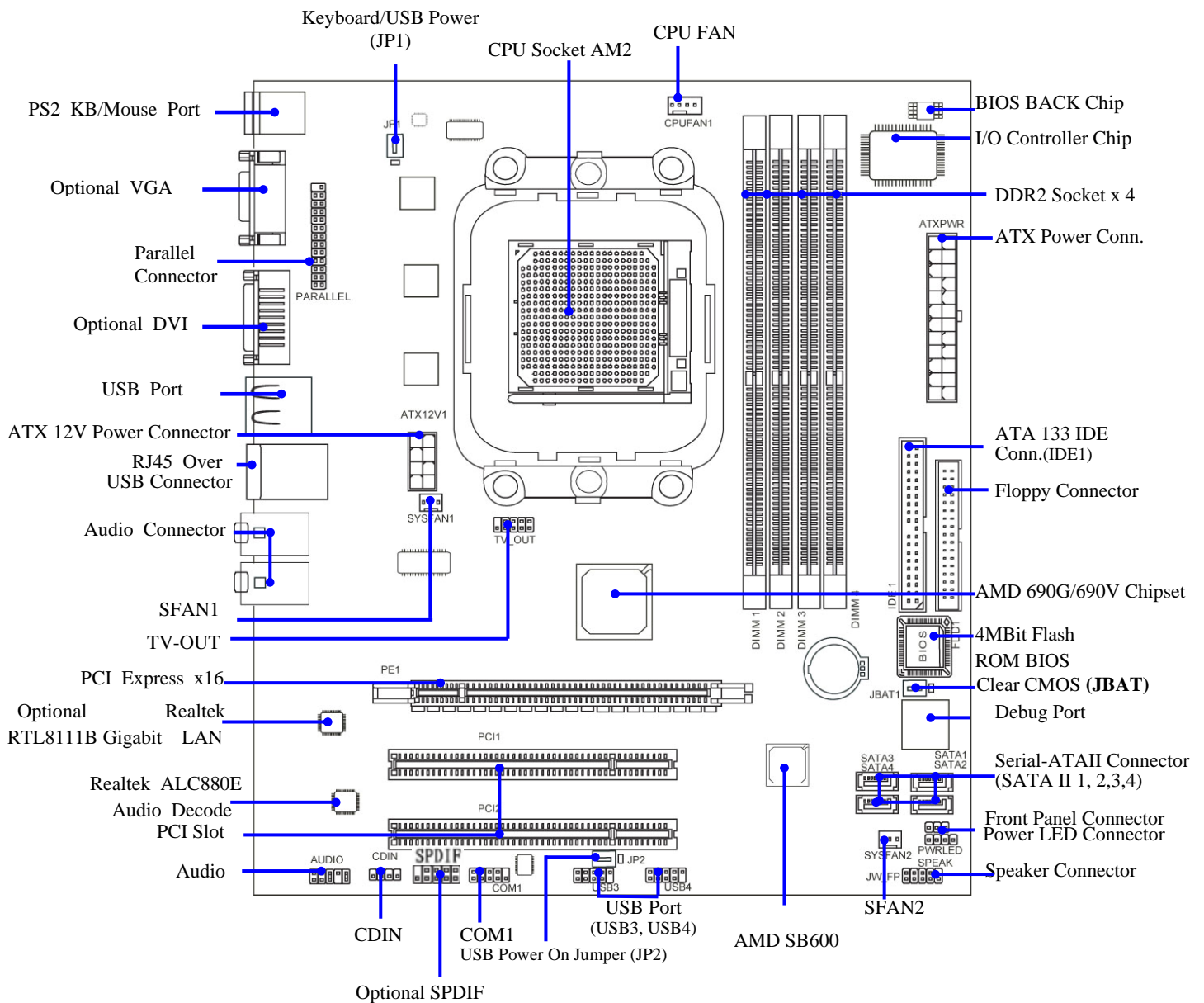

---

---

## Chapter 2

### Hardware Installation

#### 2-1 Install Socket AM2 Supported AMD Processor

This motherboard provides a 940-pin surface mount, Zero Insertion Force (ZIF) socket, referred to as the mPGA940 socket supports AMD Athlon64 processor in the 940 Pin package utilizes Flip-Chip Pin Grid Array package technology.

The CPU that comes with the motherboard should have a cooling FAN attached to prevent overheating. If this is not the case, then purchase a correct cooling FAN before you turn on your system.

**WARNING!** Be sure that there is sufficient air circulation across the processor's heatsink and CPU cooling FAN is working correctly, otherwise it may cause the processor and motherboard overheat and damage, you may install an auxiliary cooling FAN, if necessary.

To install a CPU, first turn off your system and remove its cover. Locate the ZIF socket and open it by first pulling the level sideways away from the socket then upward to a 90-degree angle. Insert the CPU with the correct orientation as shown below. The notched corner should point toward the end of the level. Because the CPU has a corner pin for two of the four corners, the CPU will only fit in the orientation as shown.

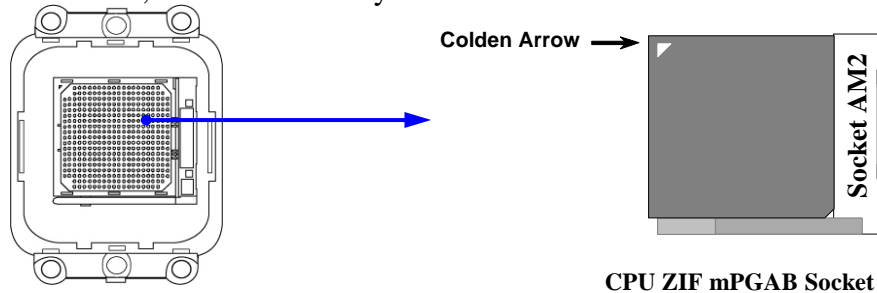

When you put the CPU into the ZIF socket, No force require to insert of the CPU, then press the level to Locate position slightly without any extra force.

#### 2-4 Install Memory

This motherboard provides four 240-pin DDR2 DUAL INLINE MEMORY MODULES (DIMM) socket for DDR2 memory expansion available from minimum memory volume of 128MB to maximum memory volume of 8.0GB DDR SDRAM.

##### Valid Memory Configurations

Bank	240-Pin DIMM	PCS	Total Memory
Bank 0, 1 (DIMM1)	DDR2 533/DDR2 667/DDR2 800	X1	128MB~2.0GB
Bank 2, 3 (DIMM2)	DDR2 533/DDR2 667/DDR2 800	X1	128MB~2.0GB
Bank 4, 5 (DIMM3)	DDR2 533/DDR2 667/DDR2 800	X1	128MB~2.0GB
Bank 6,7 (DIMM4)	DDR2 533/DDR2 667/DDR2 800	X1	128MB~2.0GB
Total	System Memory (Max. 8.0GB)	4	128MB~8.0GB

### **Recommend DIMM Module Combination**

1. **One DIMM Module ---Plug in DIMM1**
2. **Two DIMM Modules---Plug in DIMM1 and DIMM2 for Dual channel function**
3. **Four DIMM Modules---Plug in DIMM1/DIMM2/DIMM3/DIMM4.**

### **For Dual channel Limited!**

4. Dual channel function only supports when 2 DIMM Modules plug in either both DIMM1 & DIMM2 or DIMM3 & DIMM4, or four DIMM Modules plug in DIMM1~DIMM4.
5. DIMM1 & DIMM2 or DIMM3 & DIMM4 must be the same type, same size, same frequency for dual channel function.

Install DDR SDRAM modules to your motherboard is not difficult, you can refer to figure below to see how to install a 240-Pin DDR2 533/DDR2 667/DDR2 800 SDRAM module.

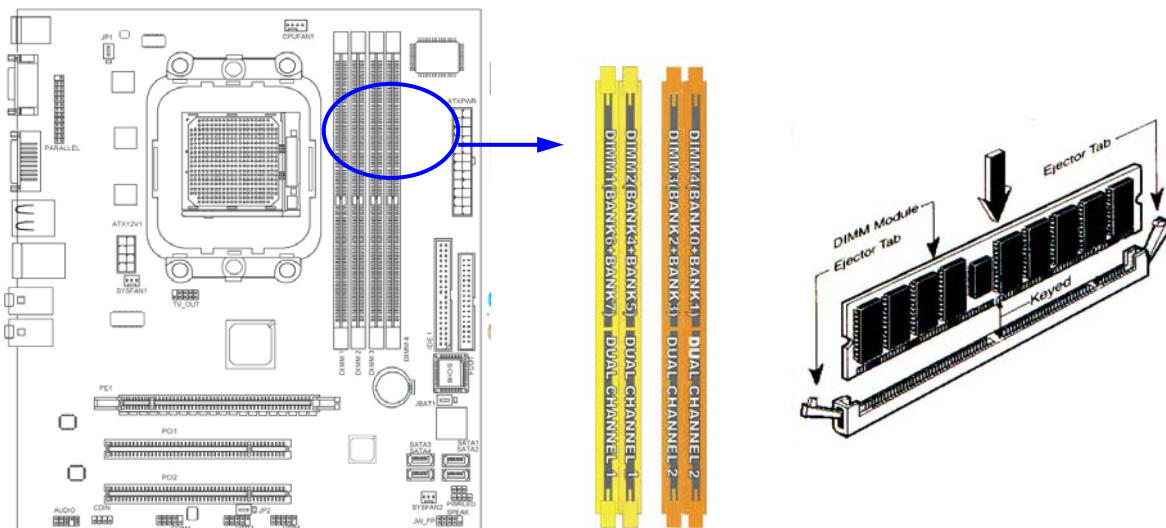

**NOTE!** When you install DIMM module fully into the DIMM socket the eject tab should be locked into the DIMM module very firmly and fit into its indentation on both sides.

**WARNING!** For the DDR SDRAM CLOCK is set at 400MHz, use only DDR2 800- compliant DDR2 Modules. When this motherboard operate at 400Mhz, most system will not even boot if non-compliant modules are used because of the strict timing issues, if your DDR Modules are not DDR2 800-compliant, set the SDRAM clock to 200MHz to ensure system stability.



---

---

## 2-3 Expansion Cards

The motherboards offer one PCI-Express x16 graphics slot of 4Gbyte/sec data transfer rate at each relative direction which gets 3.5 times of bandwidth more than AGP 8X and it's up to a peak concurrent bandwidth of 8Gbyte/sec at full speed to guarantee the ultimate GPU computing performance. Two 32-bit PCI slots guarantee the rich connectivity for the I/O of peripherals; the motherboards are designed of tackling the profuse multimedia requirements nowadays.

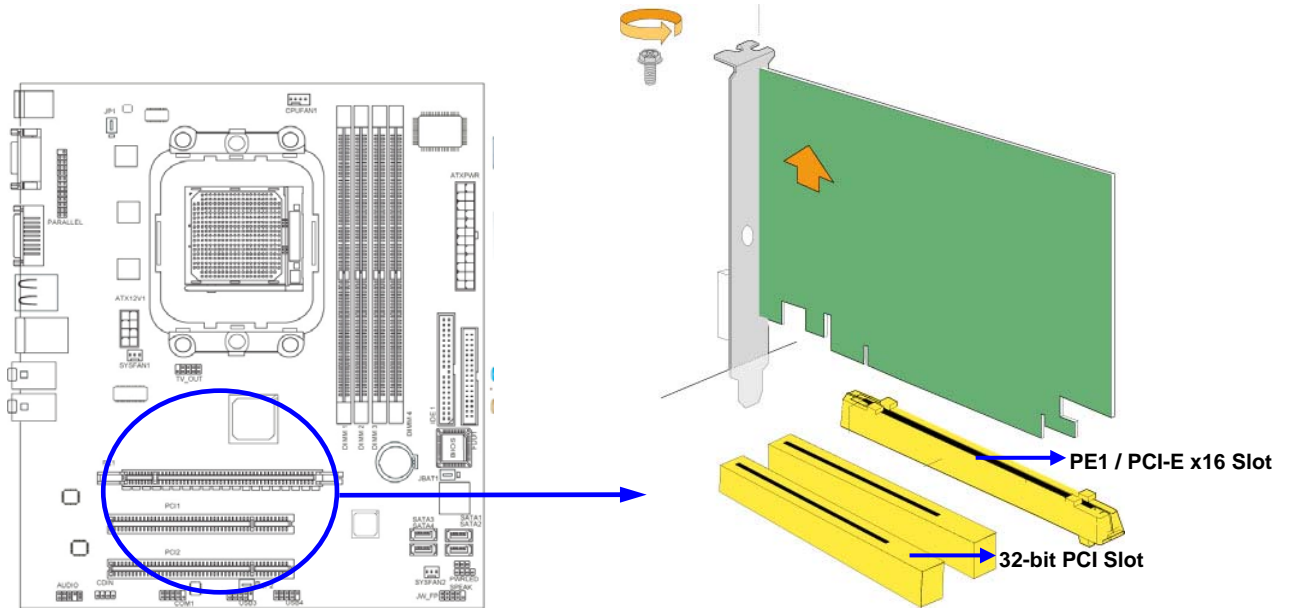

# Chapter 3

## Connectors, Headers & Jumpers Setting

### 3-1 Connectors

(1) **Power Connector (24-pinblock) : ATXPWR1**

ATX Power Supply connector: This is a new defined 24-pins connector that usually comes with ATX case. The ATX Power Supply allows using soft power on momentary switch that connect from the front panel switch to 2-pins Power On jumper pole on the motherboard. When the power switch on the back of the ATX power supply turned on, the full power will not come into the system board until the front panel switch is momentarily pressed. Press this switch again will turn off the power to the system board.

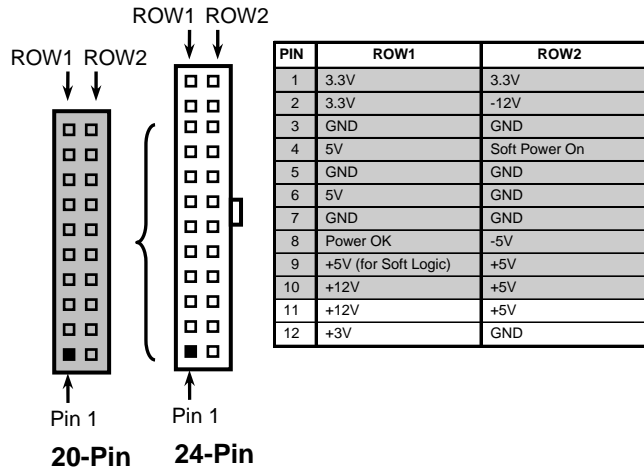

- \*\* We recommend that you use an ATX 12V Specification 2.0-compliant power supply unit (PSU) with a minimum of 350W power rating. This type has 24-pin and 4-pin plugs.
- \*\* If you intend to use a PSU with 20-pin and 4-pin power plugs, make sure that the 20-pin power plug can provide at least 15A on +12V and the power supply unit has a minimum power rating of 350W. The system may become unstable or may not boot up if the power is inadequate.

(2) **ATX 12V Power Connector (8-pin block) : ATX12V1**

This is a new defined 8-pins connector that usually comes with ATX Power Supply. The ATX Power Supply which fully supports AM2 processor must including this connector for support extra 12V voltage to maintain system power consumption. Without this connector might cause system unstable because the power supply can not provide sufficient current for system.



(3) **PS/2 Mouse & PS/2 Keyboard Connector: KB1**

The connectors are for PS/2 keyboard and PS/2 Mouse

(4) **USB Port connector: CN3**

The connectors are 4-pin connectors that connect USB devices to the system board.

(5) **LAN Port connector: UL1**

This connector is standard RJ45 connector for Network The USBLAN1 support optional 10M/100M or 10M/100Mb/1000Mb s data transfer rate

(6) **Audio Line-In, Lin-Out, MIC, Surrback, Surround, CEN/LEF Connector: SURROUND1 / CN1**

This Connector are 6 phone Jack for LINE-OUT, LINE-IN, MIC, Surrback, Surround, CEN/LEF

- Line-in : (BLUE)** Audio input to sound chip
- Line-out : (GREEN)** Audio output to speaker
- MIC : (PINK)** Microphone Connector
- Surrback : (ORANGE)** Audio output to speaker-Rear speaker out
- CEN/LEF : (BLACKNESS)** Audio output to speaker-Center/Subwoofer speaker out
- Surround: (GRAY)** Audio output to speaker-Side speaker out

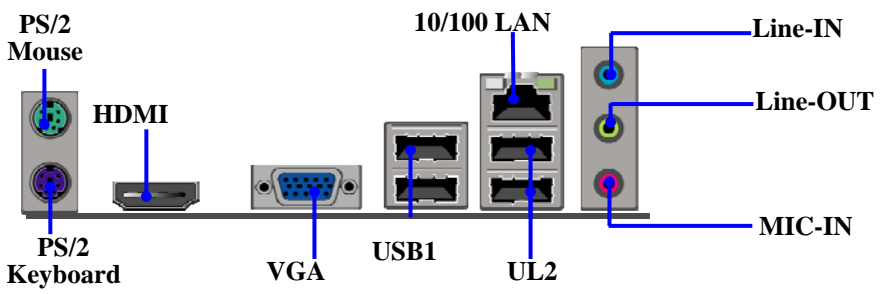
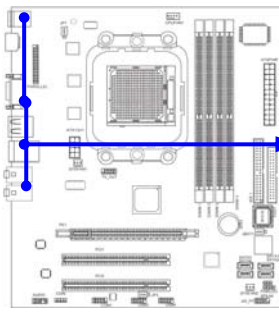
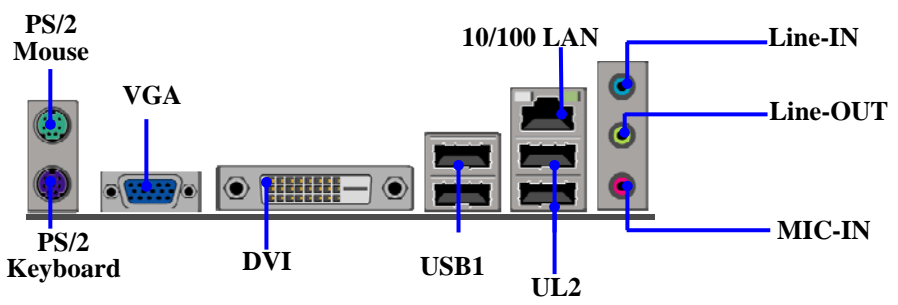
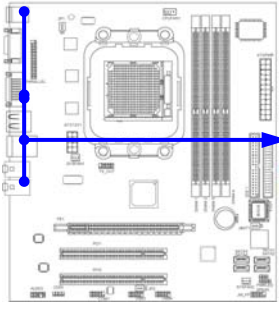
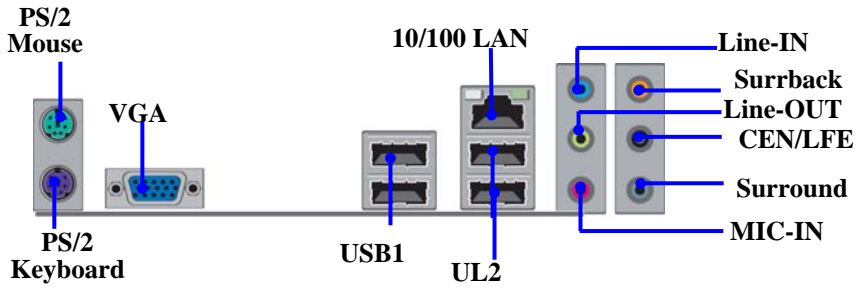
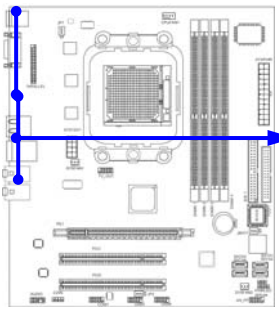
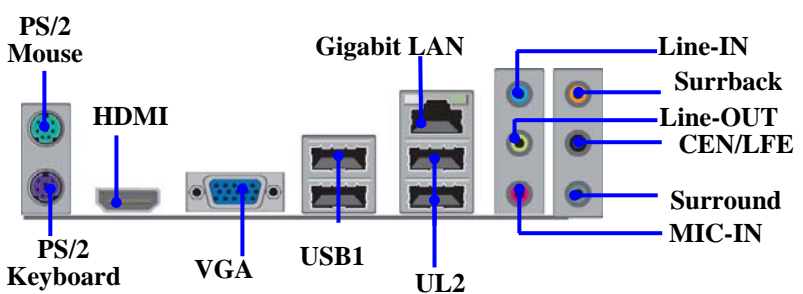
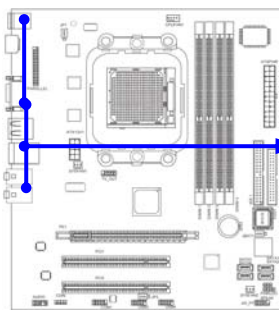
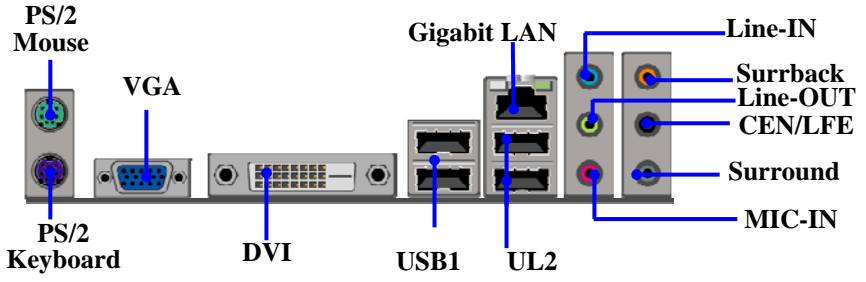
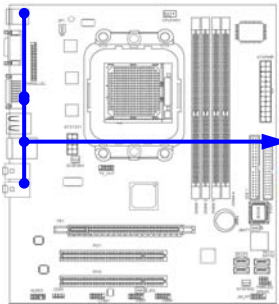

---

---

**(7) Floppy drive Connector (34-pin block): FDD1**

This connector supports the provided floppy drive ribbon cable. After connecting the single plug end to motherboard, connect the two plugs at other end to the floppy drives.

**(8) Primary IDE Connector (40-pin block): IDE1**

This connector connects to the next set of Master and Slave hard disks. Follow the same procedure described for the primary IDE connector. You may also configure two hard disks to be both Masters using one ribbon cable on the primary IDE connector and another ribbon cable on the secondary IDE connector.

- Two hard disks can be connected to each connector. The first HDD is referred to as the “Master” and the second HDD is referred to as the “Slave”.
- For performance issues, we strongly suggest you don’t install a CD-ROM or DVD-ROM drive on the same IDE channel as a hard disk. Otherwise, the system performance on this channel may drop.

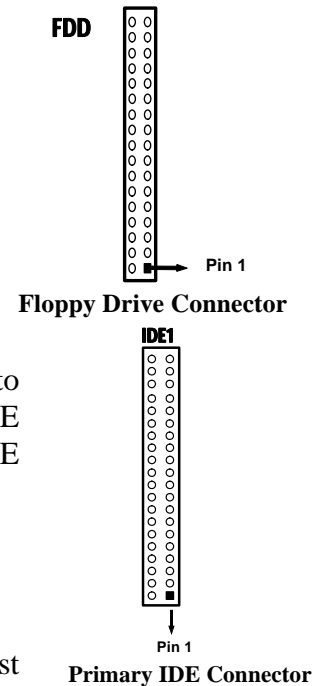

**(9) Serial-ATA Port connector:**

**SATA1 / SATA2 / SATA3/ SATA4**

These connectors support the provided Serial ATA and Serial ATA2 IDE hard disk cable to connecting the motherboard and serial ATA hard disk.

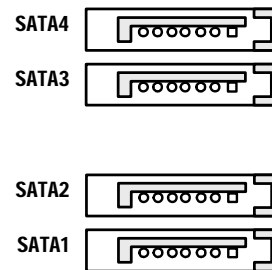

**Serial-ATA1 & 2 Compatible Connectors**

**(10) D-Sub 15-pin Connector: VGA**

VGA is the 15-pin D-Subminiature female connector; it is for the display devices, such as the CRT monitor, LCD monitor and so on.

**(11) DVI: Digital Visual Interface (Optional)**

This interface standard designed to maximize the visual quality of digital display devices such as flat panel LCD computer displays and digital projectors.

**(12) HDMI: High-Definition Multimedia Interface (Optional)**

This point-to-point interface is for audio and video signals designed as a single-cable solution for home theater and consumer electronics equipment.

## 3-2 Headers

### (1) Line-Out/MIC Header for Front Panel (9-pin): AUDIO1

These headers connect to Front Panel Line-out, MIC connector with cable. Without install the cable, this header default setting is 5-6 short, 9-10 short. When you install the cable you have take off these jumpers.

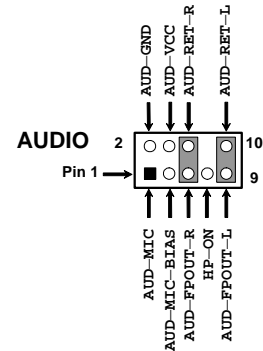

Line-Out, MIC Headers

### (2) USB Port Headers (9-pin) :

#### USB3 / USB4

These headers are used for connecting the additional USB port plug. By attaching an option USB cable, your can be provided with two additional USB plugs affixed to the back panel.

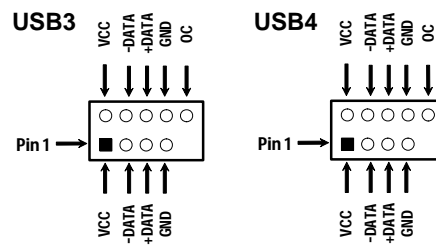

USB Port Headers

### (3) Speaker connector: SPEAK1

This 4-pin connector connects to the case-mounted speaker. See the figure below.

### (4) Power LED: PWR LED1

The Power LED is light on while the system power is on. Connect the Power LED from the system case to this pin.

### (5) IDE Activity LED: HD LED

This connector connects to the hard disk activity indicator light on the case.

### (6) Reset switch lead: RESET

This 2-pin connector connects to the case-mounted reset switch for rebooting your computer without having to turn off your power switch. This is a preferred method of rebooting in order to prolong the life of the system's power supply. See the figure below.

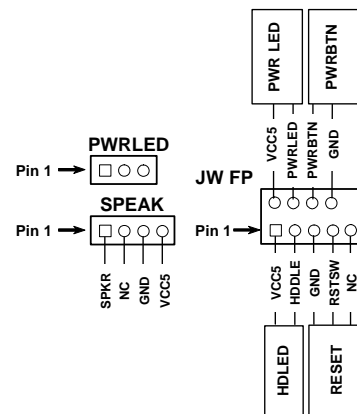

System Case Connections

### (7) Power switch: PWR BTN

This 2-pin connector connects to the case-mounted power switch to power ON/OFF the system.

**(8) FAN Power Headers: SYSFAN1, SYSFAN2 (3-pin), CPUFAN (4-pin)**

These connectors support cooling fans of 350mA (4.2 Watts) or less, depending on the fan manufacturer, the wire and plug may be different. The red wire should be positive, while the black should be ground. Connect the fan's plug to the board taking into consideration the polarity of connector.

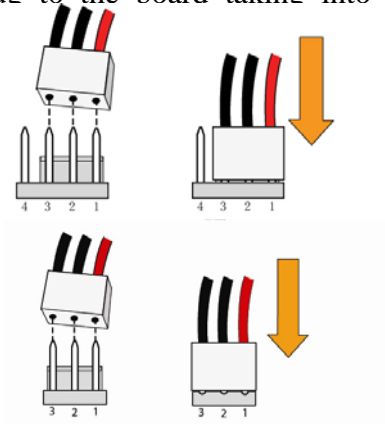
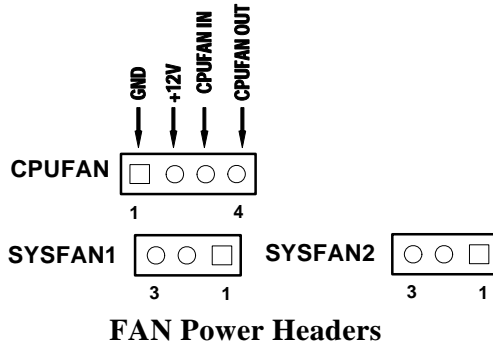

**(9) CD Audio-In Headers (4-pin) : CDIN**

CDIN are the connectors for CD-Audio Input signal. Please connect it to CD-ROM CD-Audio output connector.

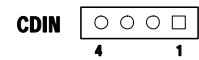

**CD Audio-In Headers**

**(10) Parallel Port Header (25-pin male): PARALLEL1**

The On-board Parallel Port can be disabled through the BIOS SETUP.

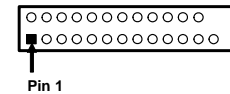

**PARALLEL**

**(11) Serial COM Port Header: COM1**

COM1 is the 9-pin block pin-header. The On-board serial port can be disabled through BIOS SETUP.

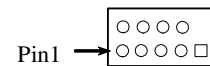

**Serial COM Port 9-pin Block**

**(12) TV-OUT Header**

TV-OUT is the 9-pin block pin-header..TV-out is commonly used to label the connector of equipment offering an analog video signal that is acceptable for a television AV input.



**TV-OUT Conn. 9-pin Block**

---

---

## Chapter 4

### USEFUL HELP

#### 4-1 HOW TO UPDATE BIOS

Before updating the BIOS, users have to “Disable” the “Flash Part Write Protect” selection in “Miscellaneous Control” of BIOS SETUP. Otherwise the system will not allow you to upgrade BIOS by Award Flash Utility.

**STEP 1.** Prepare a boot disc. (you may make one by click START click RUN type SYS A:click OK)

**STEP 2.** Copy utility program to your boot disc. You may copy from DRIVER CD  
X:\FLASH\AWDFLASH.EXE or download from our web site.

**STEP 3.** Download and make a copy of the latest BIOS for **AMD690X** PPC motherboard series from the web site to your boot disc.

**STEP 4.** Insert your boot disc into A:,

start the computer, type “Awdflash A:\ **AMD690X**.BIN /SN/PY/CC/R”

**AMD690X xxx**.BIN is the file name of latest BIOS it can be **AMD690Xa**.BIN or **AMD690Xb**.BIN

SN means don't save existing BIOS data

PY means renew existing BIOS data

CC means clear existing CMOS data

R means restart computer

**STEP 5.** Push ENTER to update and flash the BIOS, then the system will restart automatically.

#### 4-2 Trouble Shooting

Problem	Solution
No power to the system to the all power light don't illuminate, fan inside power supply doesn't turn on.	1. Make sure power cable is security plugged in. 2. Replace cable. 3. Contact technical support.
System inoperative. Keyboard lights are on , power indicator lights are lit, and hard drive is spinning.	Using ever pressure on both ends of the DIMM , press down firmly until the module snaps into places.
System doesn't boot from hard disk drive, can be booted from optical drive.	1. Check cable running from disk to disk controller board. .Make sure both ends are securely plugged in, check the drive type in the standard CMOS setup. 2. Backing up the hard drive is extremely important .All hard disks are capable of breaking down at any time.
System only boots from optical drive .Hard disk can be read and applications can be used but booting from hard disk is impossible.	1. Back up date and applications files. 2. Reformat the hard drive. Reinstall applications and date using backup disks.
Screen message says “Invalid Configuration” or “CMOS Failure”	Review system 's equipment .Make sure correct information on is in setup.
Can not boot system after installing second hard drive.	1. Set master /slave jumpers correctly. 2. Run SETUP program and select correct drive types. Call the drive manufacture for compatibility with other drives.

---

---

## 4-3 The Introduction of BIOS BACK Function (Optional)

### Advanced BIOS Back & Recovery Function

“BIOS Back” function is automatically activated when the original BIOS malfunction occurs. When it occurs to BIOS malfunction, the BIOS BACK function will be activated automatically, then the system will restart to reload the BIOS backup to the system boot up menu as the following figure. It takes 4 to 8 seconds to get into the boot up menu and here comes the message, “Warning! Now System is BACKUP BIOS. Please reflash primary BIOS.” after system reboots. And then, please follow the OSD to press “F1” button to continue to log on your operation system.

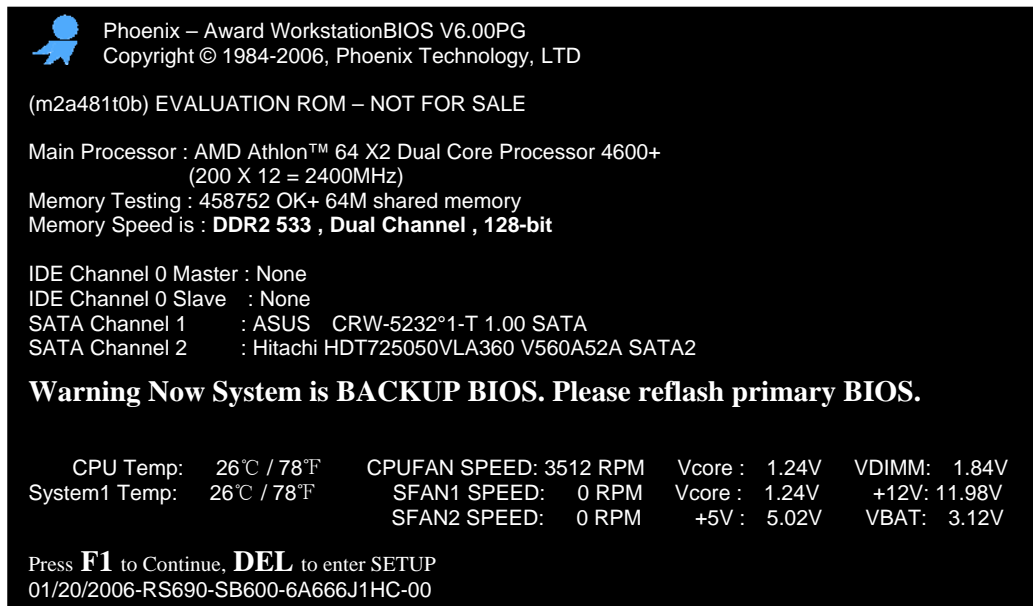

Please make sure to Update the BIOS after getting into operation system, or the BIOS BACK function will check your primary BIOS status every time, and it may cause your inconvenience too.