

***USER'S MANUAL***  
***Of***  
***AMD 480X CHIPSET***  
***&***  
***AMD SB600 Chipset Based***  
***M/B For Socket AM2 64-bit Dual Core***  
***AMD Processor***

***No. G03-M2A480-F***

***Rev:3.0***

***Release date: April 2007***

**Trademark:**

\* Specifications and Information contained in this documentation are furnished for information use only, and are subject to change at any time without notice, and should not be construed as a commitment by manufacturer.

---

---

# TABLE OF CONTENT

---

---

<b>CHAPTER 1 INTRODUCTION OF AMD 480X MOTHERBOARD SERIES</b>	
1-1 FEATURES OF MOTHERBOARD .....	1
1-1.1 SPECIAL FEATURES OF MOTHERBOARD.....	2
1-2 SPECIFICATION.....	3
1-3 ITEM CHECKLIST .....	4
1-4 LAYOUT DIAGRAM & JUMPER SETTING OF CROSSFIRE MOTHERBOARD ...	4
1-5 LAYOUT DIAGRAM & JUMPER SETTING WITHOUT CROSSFIRE SUPPORT ...	5
<b>CHAPTER 2 HARDWARE INSTALLATION</b>	
2-1 INSTALL SOCKET AM2 SUPPORTED AMD PROCESSOR.....	6
2-2 INSTALL MEMORY .....	6
2-3 EXPANSION CARDS OF CROSSFIRE MOTHERBOARDS .....	8
2-4 EXPANSION CARDS OF MOTHERBOARDS WITHOUT CROSSFIRE.....	8
2-5 BRIDGES FOR CROSSFIRE TECH. SUPPORTED VGA CARDS.....	9
<b>CHAPTER 3 CONNCTORS, HEADERS &amp; JUMPERS SETTING</b>	
3-1 CONNECTORS .....	10
3-2 HEADERS .....	12
<b>CHAPTER 4 USEFUL HELP</b>	
4-1 HOW TO UPDATE BIOS.....	15
4-2 TROUBLE SHOOTING .....	15
4-3 THE INTRODUCTION OF DIY COOL FUNCTION.....	16
4-4 THE INTRODUCTION OF BIOS BACK FUNCTION.....	16

## Environmental Protection Announcement

Do not dispose this electronic device into the trash while discarding. To minimize pollution and ensure environment protection of mother earth, please recycle.



---

---

# Chapter 1

## Introduction of AMD 480X Motherboard Series

### 1-1 Features of motherboard

The AMD 480X Series motherboards are based on the latest AMD 480X Chipset and SB600 chipset which supports the new generation innovative 64-bit AMD Socket AM2 dual core multi-tasking Socket AM2 Athlon64 X2 processors. With an integrated low-latency high-bandwidth DDR2 memory controller and the highly-scalable Hyper Transport technology-based system bus which is up to 1000 MHZ, AMD 480X Platform Processor Chipset motherboard series deliver the outstanding system performance and professional desktop platform solution with the advantages of new generation 64-bit AMD Socket AM2 Athlon64 X2 processors and the fully compatibility of the next generation operation system.

The AMD 480X Series motherboards support new generation Socket AM2 processors with an integrated DDR2 memory controller which provides with 266MHz / 333MHz/ 400MHz memory clock frequency for Dual channel DDR2 533 / DDR2 667 / DDR2 800 (Sempron processor of AM2 socket only supports up DDR2 667) DDR2 Module up to 8.0GB (The AMD 480X motherboard with no CrossFire Tech. supported editions offer 2 DIMM slots which can only be expandable to 4 GB in some particular models). The whole motherboard series are embedded with SB600 chipset that provides ULTRA ATA 133 connectors and Serial ATA2 with RAID 0, 1 and RAID 10 functions which support up to two IDE devices and four Serial ATA2 devices to accelerate hard disk drives and guarantee the data security without failure in advanced computing performance.

The AMD 480X motherboard of CrossFire Tech. supported editions that provide 10 / 100 / 1000 LAN function with RTL8111 PCI-E Gigabit LAN controller which supports 10 / 100 / 1000Mbps data transfer rate. And the embedded HD Azalia 8-channel Audio CODEC is fully compatible with Sound Blaster Pro<sup>®</sup> standards offer you with the home cinema quality and satisfying software compatibility (The AMD 480X motherboard with no CrossFire Tech. supported editions provide optional 10 / 100 LAN function with Realtek RT8101E PCI-E 10 / 100 LAN which supports 10 / 100Mbps data transfer rate. Embedded 6-channel AC' 97 Audio CODEC which is also fully compatible with Sound Blaster Pro<sup>®</sup> standard. ).

The AMD 480X motherboard of CrossFire Tech. supported edition offers two PCI-Express x16 graphics slots; when install the "Switch Card" into PE-3 slot, the "PE-1" PCI-Express x16 graphics slot offers 16-LANE Bandwidth which get 3.5 times of bandwidth more than AGP8X and up to 8 Gbyte/sec concurrent bandwidth at full speed. When activating the ATi CrossFire Technology, both of these two PCI-Express x16 graphics slots can offer 8-lane + 8-lane bandwidth to guarantee the fully operational multi-GPUs graphics power and avoid the possible CrossFire hardware installation error. The AMD 480X motherboard of CrossFire Tech. supported edition carries two 32-bit PCI slots of the rich connectivity for the I/O peripheral devices. One PCI Express x1 I/O slot offers 512Mbyte/sec concurrently, over 3.5 times more bandwidth than PCI at 133Mbyte/sec, tackling the most demanding multimedia tasks nowadays.

The AMD 480X motherboard with no CrossFire Tech. supported editions offer one PCI-Express x16 graphics slot of 4Gbyte/sec data transfer rate at each relative direction which gets 3.5 times of bandwidth more than AGP 8X and it's up to a peak concurrent bandwidth of 8Gbyte/sec at full speed to guarantee the ultimate GPU computing performance. Three 32-bit PCI slots guarantee the rich connectivity for the I/O of peripherals. One PCI Express x1 I/O slots offer 512Mbyte/sec concurrently

---

---

bandwidth which is over 3.5 times than 32-bit PCI at 133Mbyte/sec; the motherboards are designed of tackling the profuse multimedia requirements nowadays)

Embedded USB controller as well as capability of expanding to 10 of USB2.0 functional ports delivering 480Mb/s bandwidth and rich connectivity, these motherboards meet the future USB demands which are also equipped with hardware monitor function on system to monitor and protect your system and maintain your non-stop business computing.

Some special features---*CPU Thermal Throttling/ CPU Vcore 7-shift / CPU Smart Fan / Optional DeBug Port (Only for CrossFire Tech. Supported Edition ) / Optional BIOS BACK Function (Only for CrossFire Tech. Supported Edition )* in this motherboard are designed for power user to use the over-clocking function in more flexible ways. But please be caution that the over-clocking maybe cause the fails in system reliabilities. This motherboard provides the guaranteed performance and meets the demands of the next generation computing. But if you insist to gain more system performance with variety possibilities of the components you choose, please be careful and make sure to read the detailed descriptions of these value added product features, please get them in the coming section.

## 1-1.1 Special Features of Motherboard

### **Debug Port (Option)**--- ( The Professional Hardware Diagnosis System )

Being bugged of abnormal system failure through the tossed and turned nights no more, the embedded Hardware Debug Port offers you the real-time visual system healthy for the demanding usage of computing. No more bugging by unknown system failure and no more time wasted in the first moment of 24-hour nonstop ping business computing, the embedded Debug Port will turn you into a well training hardware professional with the seeing system situation. (The Post Code please refer to the Website)

### **CPU Smart Fan**---( The Noise Management System )

It's never been a good idea to gain the performance of your system by sacrificing its acoustics. CPU Smart Fan Noise Management System is the answer to control the noise level needed for now-a-day's high performance computing system. The system will automatically increase the fan speed when CPU operating loading is high, after the CPU is in normal operating condition, the system will low down the fan speed for the silent operating environment. The system can provide the much longer life cycle for both CPU and the system fans for game use and business requirements.

### **CPU Vcore 7-Shift**--- (Shift to Higher Performance)

The CPU voltage can be adjusted up by 7 steps for the precisely over-clocking of extra demanding computing performance.

### **BIOS BACK Function (Option)**--- ( The BIOS Backup and Recovery Function )

With the new support for the Serial Peripheral Interface, the whole motherboard series are embedded with the new storage of the extra bin file for BIOS recovery. When unexpected error occurs, even the BIOS crashes down, you can restore your BIOS with just simply clicking to restart your system. The backup bin file will recover automatically within a few minutes.

## 1-2 Specification

<b>Spec</b>	<b>Description</b>
<b>Design</b>	* ATX form factor 4 layers PCB size: 29.5cm*22.5cm
<b>Chipset</b>	* AMD 480X Chipset and AMD SB600 Chipset
<b>CPU Socket AM2</b>	* Support 64bit AMD AM2 940-Pin package utilizes Flip-Chip Pin Grid Array package compatible processor * Support for HTT 1GHz AMD Athlon 64 X2 processor and Athlon 64, and HTT 800MHz Sempron Processors
<b>Memory Socket</b>	* 240-pin DDR2 Module socket x 4 (CrossFire Supported Edition) * 240-pin DDR2 Module socket x 2 (With no CrossFire Edition) * Support 4 / 2 pcs DDR2 533 / DDR2 667 / DDR2 800 Modules Expandable to 8.0 / 4.0GB
<b>Expansion Slot (CrossFire Supported Edition)</b>	* PCI-Express x16 slot 2pcs; one delivers up to 8 GB/s of concurrent bandwidth with the “Switch Card” being installed, and it offers 8-LANE + 8-LANE bandwidth for CrossFire Activating. * PCI-Express x1 slot 1pcs delivers up to 512MB/s * 32-bit PCI slot x 2 pcs
<b>Expansion Slot (With no CrossFire Edition)</b>	* PCI-Express x16 slot 1pcs delivers up to 8 GB/s of concurrent bandwidth. * PCI-Express x1 slot 1pcs delivers up to 512MB/s * 32-bit PCI slot x 3 pcs
<b>Integrate IDE and Serial ATA2 RAID</b>	* One IDE controllers support PCI Bus Mastering, ATA PIO / DMA and the ULTRA DMA 33/66/100/133 functions that deliver the data transfer rate up to 133 MB/s. * Four Serial ATA2 ports provide 300 MB/sec data transfer rate with RAID 0, 1, 10 functions.
<b>Optional LAN</b>	* Integrated Realtek RTL8111 PCI-E 10 / 100 / 1000 LAN / RT8101E PCI-E10/100 LAN chip. * Support Fast Ethernet LAN function of providing 10Mb / 100Mb 1000 Mb/s or 10Mb / 100Mb/s data transfer rate
<b>6CH-Audio (Option)</b>	* Realtek 6-channel ALC655 AC'97 Audio Codec onboard * Audio driver and utility included
<b>HD 8-CH Audio (Option)</b>	* Realtek ALC880 Azalia HD 8-channel Audio Codec integrated * Support 8-channel 3D surround & Positioning Audio * Audio driver and utility included
<b>BIOS</b>	* Award 4MB Flash ROM
<b>Multi I/O</b>	* PS/2 keyboard and PS/2 mouse connectors * Floppy disk drive connector x1 * 1* Parallel port of 25-pin Block / 1 * Serial port of 9-pin Block * 1 * SPDIF of 9-pin Block * IR connector with 5-pin block x1 * USB2.0 port x 4 and headers x 6 (connecting optional cable) * Audio connector (Line-in, Line-out, MIC/ 8CH Audio)

### 1-3 Item Checklist

- AMD 480X Platform Processor Chipset based motherboard
- Cable for IDE
- CD for motherboard utilities
- Cable for Serial ATA IDE Port
- Optional Switch Card for PCI-E x16 Bandwidth Adjustment
- AMD 480X Platform Processor Chipset motherboard User's Manual

### 1-4 Layout Diagram & Jumper Setting of CrossFire Motherboard

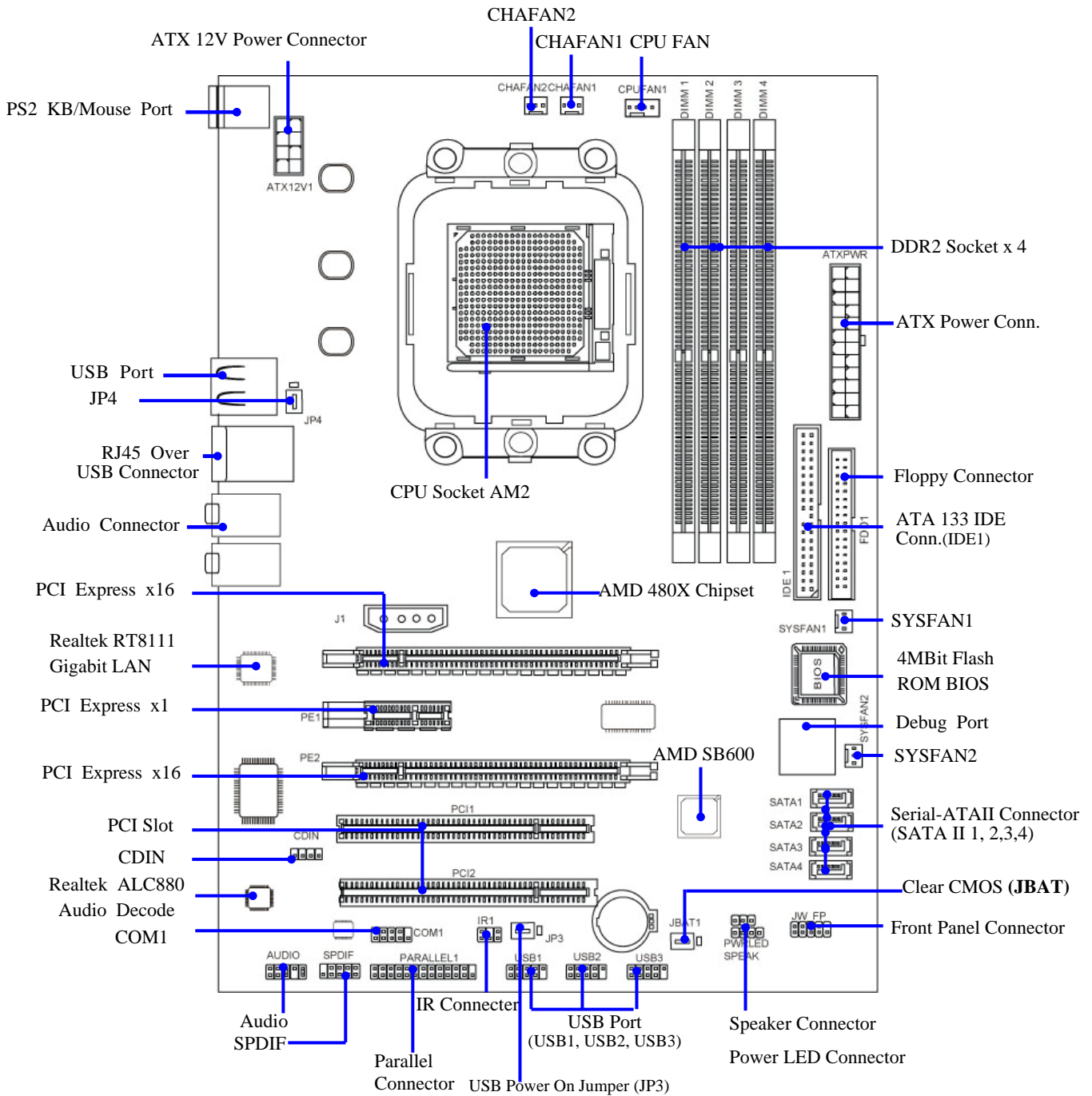

# 1-5 Layout Diagram & Jumper Setting Without CrossFire Support

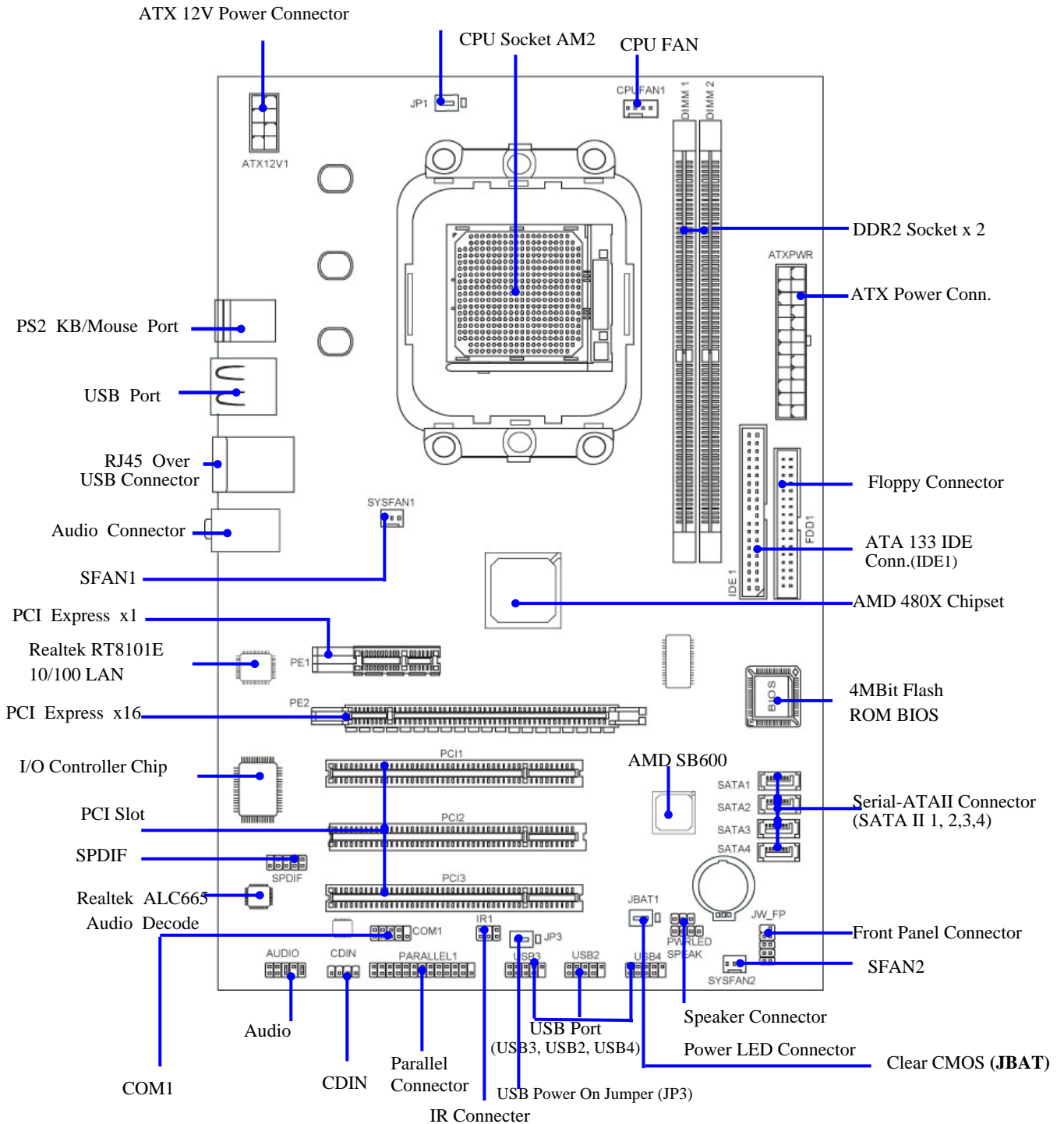

---

---

# Chapter 2

## Hardware Installation

### 2-1 Install Socket AM2 Supported AMD Processor

This motherboard provides a 940-pin surface mount, Zero Insertion Force (ZIF) socket, referred to as the mPGA940 socket supports AMD Athlon64 processor in the 940 Pin package utilizes Flip-Chip Pin Grid Array package technology.

The CPU that comes with the motherboard should have a cooling FAN attached to prevent overheating. If this is not the case, then purchase a correct cooling FAN before you turn on your system.

**WARNING!** Be sure that there is sufficient air circulation across the processor's heatsink and CPU cooling FAN is working correctly, otherwise it may cause the processor and motherboard overheat and damage, you may install an auxiliary cooling FAN, if necessary.

To install a CPU, first turn off your system and remove its cover. Locate the ZIF socket and open it by first pulling the level sideways away from the socket then upward to a 90-degree angle. Insert the CPU with the correct orientation as shown below. The notched corner should point toward the end of the level. Because the CPU has a corner pin for two of the four corners, the CPU will only fit in the orientation as shown.

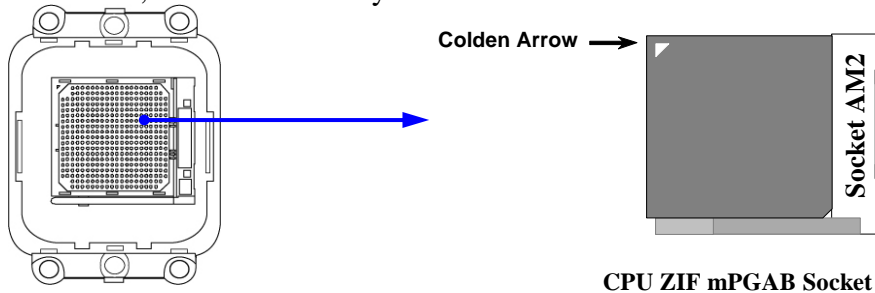

CPU ZIF mPGAB Socket

When you put the CPU into the ZIF socket. No force require to insert of the CPU, then press the level to Locate position slightly without any extra force.

### 2-2 Install Memory

The motherboards provide **four / two** 240-pin DDRII DUAL INLINE MEMORY MODULES (DIMM) sites for DDRII memory expansion available from minimum memory size of 128MB to maximum memory size of 8.0GB / 4.0GB DDRII SDRAM.

#### Valid Memory Configurations of 2-DIMM Design Motherboard

Bank	240-Pin DIMM	PCS	Total Memory
Bank 0, 1 (DIMM1)	DDRII400/DDRII533/DDRII667/DDRII800	X1	128MB~2.0GB
Bank 2, 3 (DIMM2)	DDRII400/DDRII533/DDRII667/DDRII800	X1	128MB~2.0GB
Total	System Memory (Max. 4.0GB)	2	128MB~4.0GB



## Valid Memory Configurations of 4-DIMM Design Motherboard

Bank	240-Pin DIMM	PCS	Total Memory
Bank 0, 1 (DIMM1)	DDRII400/DDRII533/DDRII667/DDRII800	X1	128MB~2.0GB
Bank 2, 3 (DIMM2)	DDRII400/DDRII533/DDRII667/DDRII800	X1	128MB~2.0GB
Bank 4, 5 (DIMM3)	DDRII400/DDRII533/DDRII667/DDRII800	X1	128MB~2.0GB
Bank 6,7 (DIMM4)	DDRII400/DDRII533/DDRII667/DDRII800	X1	128MB~2.0GB
Total	System Memory (Max. 8.0GB)	4	128MB~8.0GB

### Recommend DIMM Module Combination

1. **One DIMM Module ---Plug in DIMM1**
2. **Two DIMM Modules---Plug in DIMM1 and DIMM2 or DIMM3 and DIMM4 for Dual channel function of 4-DIMM Design motherboard and Plug in DIMM1 and DIMM2 for Dual channel function of 2-DIMM Design motherboard.**
3. **Four DIMM Modules---Plug in DIMM1/DIMM2/DIMM3/DIMM4.**

### For Dual channel Limited!

1. Dual channel function only supports when 2 DIMM Modules plug in either both DIMM1 & DIMM2 or DIMM3 & DIMM4, or four DIMM Modules plug in DIMM1~DIMM4 of 4-DIMM motherboard and 2 DIMM Modules plug in DIMM1 & DIMM2 of 2-DIMM Motherboard.
2. DIMM1 & DIMM2, or DIMM3 & DIMM4 of 4-DIMM motherboard, and DIMM1 & DIMM2 of 2-DIMM motherboard must be the same type, the same size, and the same frequency for dual channel function.

Generally, installing DDR SDRAM modules to your motherboard is very easy, you can refer to figure 2-4 to see what a 240-Pin DDR2 400 / 533 / 667 / 800 SDRAM module looks like.

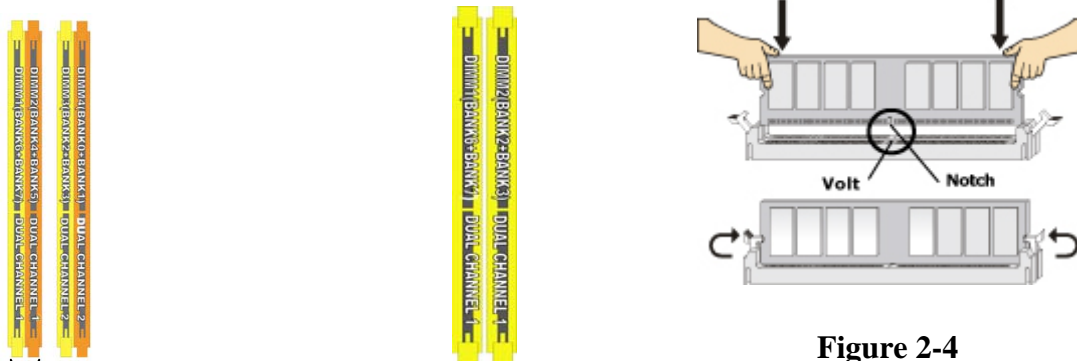

Figure 2-4

### NOTE!

When you install DIMM module fully into the DIMM socket the eject tab should be locked into the DIMM module very firmly and fit into its indentation on both sides.

---

---

## 2-3 Expansion Cards of CrossFire Motherboards

The CrossFire Tech. Supported motherboards offer two PCI-Express x16 graphics slot. When install the “Switch Card” into PE-3, the PE1 will offer 4Gbyte/sec data transfer rate at each relative direction. And when you install two ATi CrossFire Tech. Supported VGA cards to activate the Multi-VPU computing, the PE1 and PE3 slots will offer 2Gbyte/sec data transfer rate at each relative direction. One x1 PCI Express Slot that is Fully compliant to the *PCI Express Base Specification revision 1.0a* and supports PCI Express VGA card, and other PCI Express device.

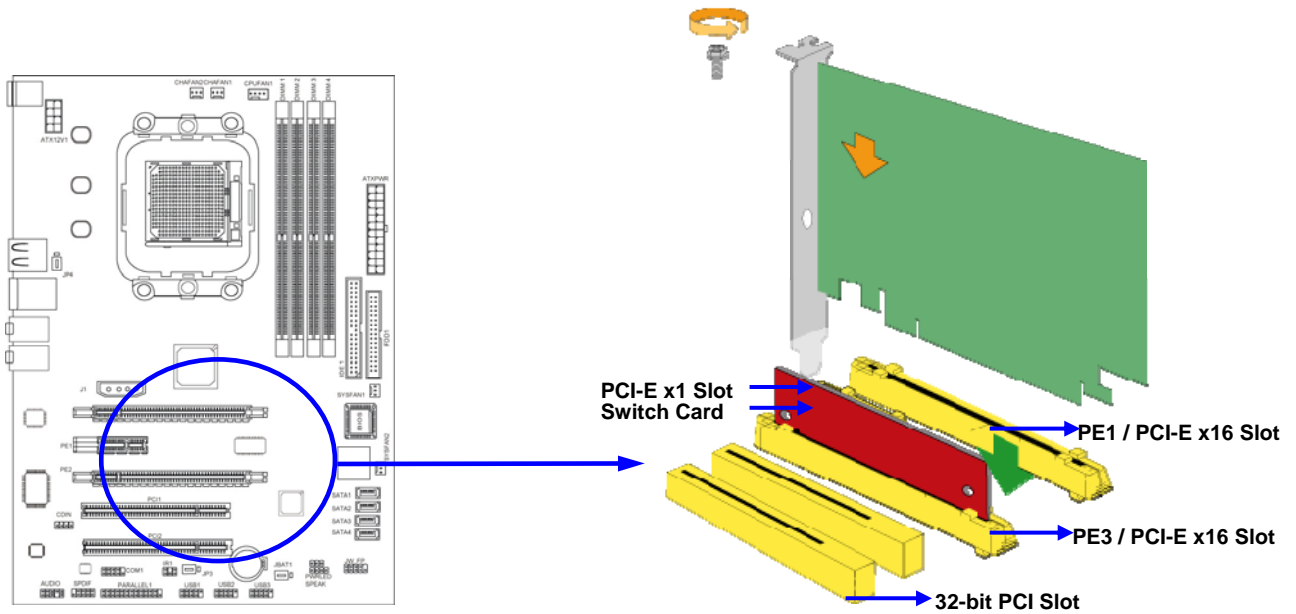

## 2-4 Expansion Cards of Motherboards Without CrossFire

Motherboards without CrossFire Tech. Support that offer one PCI-Express x16 graphics slot of 4Gbyte/sec data transfer rate at each relative direction, and one PCI Express x1 Slot which is fully compliant to the *PCI Express Base Specification revision 1.0a* , support PCI Express VGA card, and other PCI Express device.

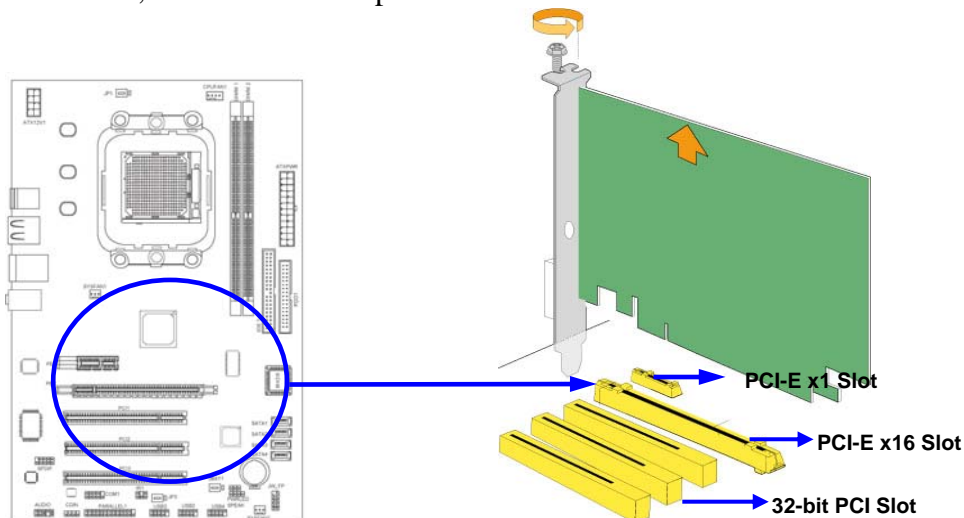

---

---

## 2-5 Bridge for CrossFire Tech. Supported VGA Cards (For AMD 480X CrossFire Tech. Motherboards Only)

In order to activate the CrossFire technology, you have to install the optional CF Bridge for your CrossFire Tech. Supported VGA Cards before you activating the advance multi-GPUs functions.

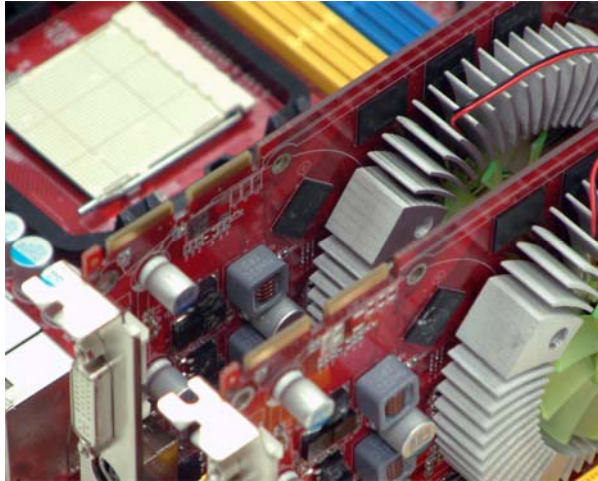

1. Install your CroFire Tech Supported VGA Cards in the PCI-E x16 slots.

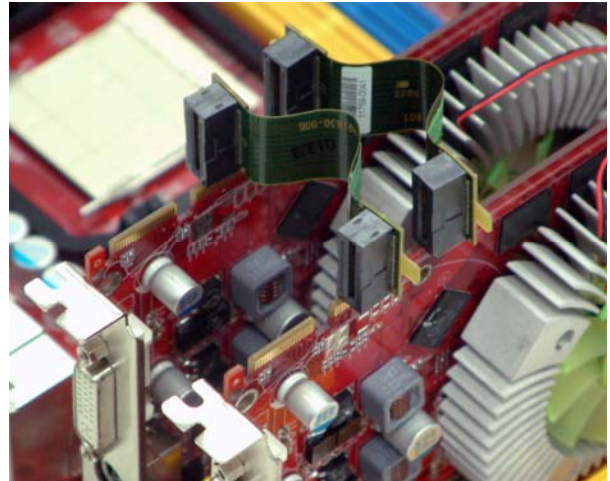

2. Prepare with the CF Bridges with your crossFire Tech Supported VGA Cards.

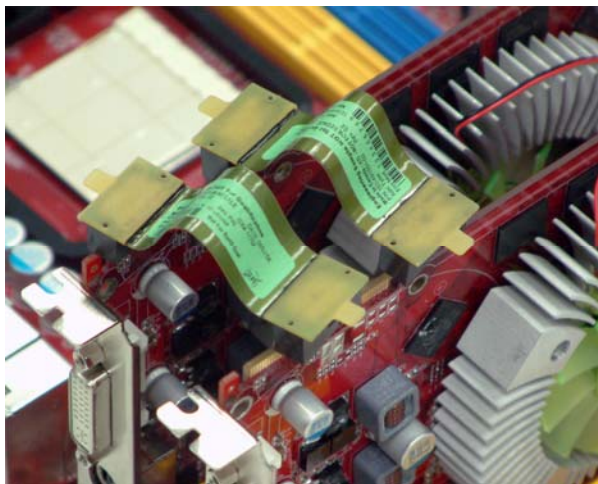

3. Be careful with the position for the pin you would like to set up.

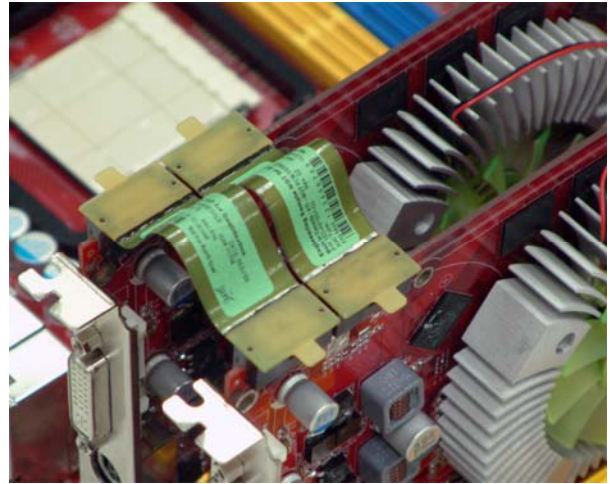

4. Keep straight to force the CF Bridges plug into both sides of CrossFire Tech Supported VGA Cards.

# Chapter 3

## Connectors, Headers & Jumpers Setting

### 3-1 Connectors

**(1) Power Connector (24-pin block) : ATXPWR1**

ATX Power Supply connector. This is a new defined 24-pins connector that usually comes with ATX case. The ATX Power Supply allows to use soft power on momentary switch that connect from the front panel switch to 2-pins Power On jumper pole on the motherboard. When the power switch on the back of the ATX power supply turned on, the full power will not come into the system board until the front panel switch is momentarily pressed. Press this switch again will turn off the power to the system board.

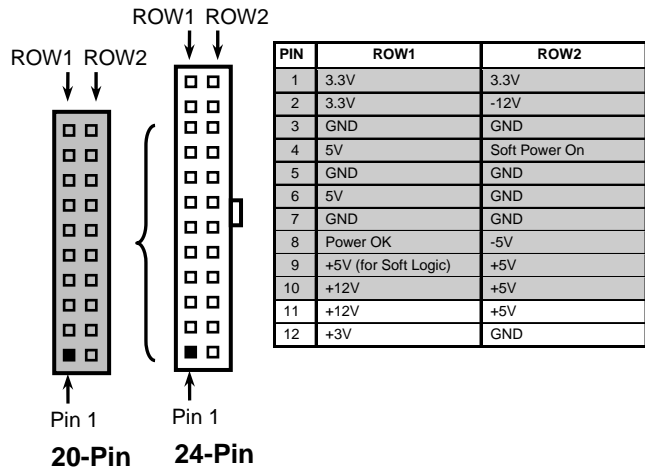

- \*\* We recommend that you use an ATX 12V Specification 2.0-compliant power supply unit (PSU) with a minimum of 350W power rating. This type has 24-pin and 4-pin power plugs.
- \*\* If you intend to use a PSU with 20-pin and 4-pin power plugs, make sure that the 20-pin power plug can provide at least 15A on +12V and the power supply unit has a minimum power rating of 350W. The system may become unstable or may not boot up if the power is inadequate.

**(2) ATX 12V Power Connector (8-pin block) : ATX12V1**

This is a new defined 8-pins connector that usually comes with ATX Power Supply. The ATX Power Supply which fully support AM2 processor must including this connector for support extra 12V voltage to maintain system power consumption. Without this connector might cause system unstable because the power supply can not provide sufficient current for system.



**(3) PS/2 Mouse & PS/2 Keyboard Connector: KB1**

The connectors for PS/2 keyboard and PS/2 Mouse.

**(4) USB Port connector: CN3**

The connectors are 4-pin connector that connect USB devices to the system board.

**(5) LAN Port connector: UL1**

This connector is standard RJ45 connector for Network  
The USBLAN1 support 10M/100Mb/1000Mb s data transfer rate

**(6) Audio Line-In, Lin-Out, MIC, Surrback, Surround, CEN/LEF Connector : SURROUND1 / CN1**

This Connector are 6 phone Jack for LINE-OUT, LINE-IN, MIC, Surrback, Surround, CEN/LEF

- Line-in : (BLUE)** Audio input to sound chip
- Line-out : (GREEN)** Audio output to speaker
- MIC : (PINK)** Microphone Connector
- Surrback : (ORANGE)** Audio output to speaker-Rear speaker out
- CEN/LEF : (BLACKNESS)** Audio output to speaker-Center/Subwoofer speaker out
- Surround: (GRAY)** Audio output to speaker-Side speaker out

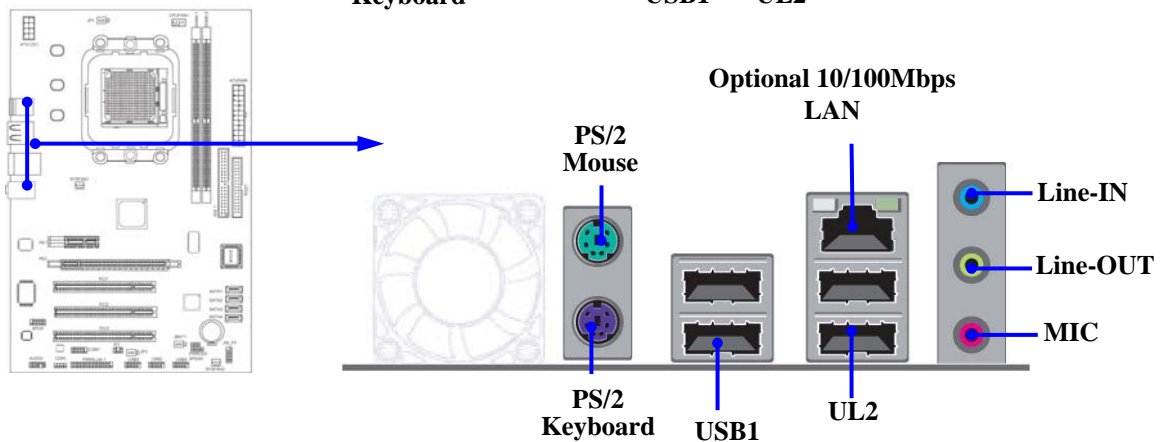
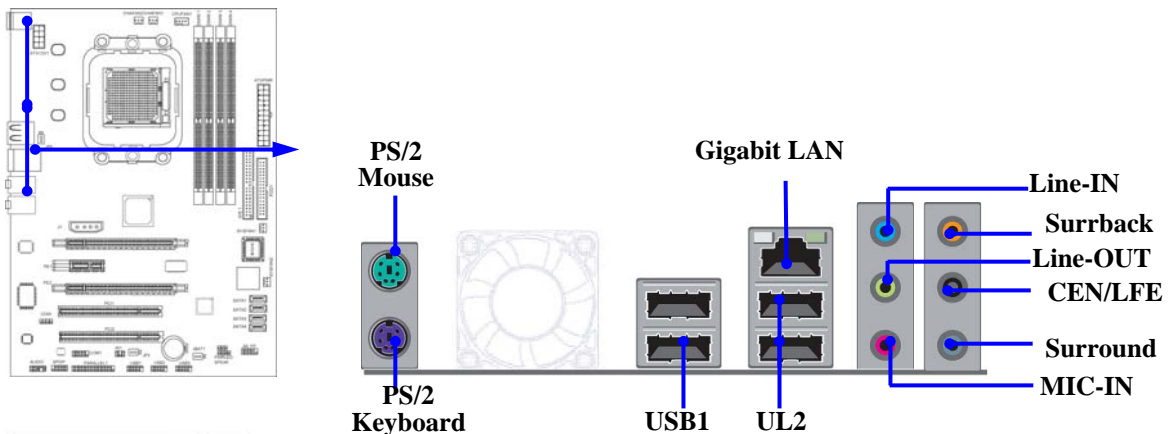

**(7) Floppy drive Connector (34-pin block): FDD1**

This connector supports the provided floppy drive ribbon cable. After connecting the single plug end to motherboard, connect the two plugs at other end to the floppy drives.

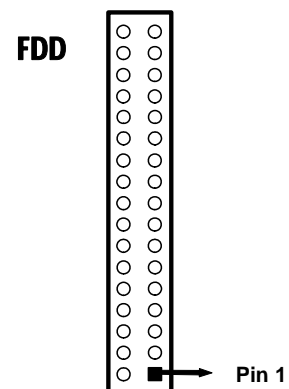

**Floppy Drive Connector**

**(8) Secondary IDE Connector (40-pin block): IDE1**

This connector connects to the next set of Master and Slave hard disks. Follow the same procedure described for the primary IDE connector. You may also configure two hard disks to be both Masters using one ribbon cable on the primary IDE connector and another ribbon cable on the secondary IDE connector.

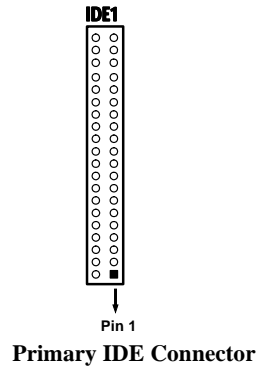

- Two hard disks can be connected to each connector. The first HDD is referred to as the “Master” and the second HDD is referred to as the “Slave”.
- For performance issues, we strongly suggest you don’t install a CD-ROM or DVD-ROM drive on the same IDE channel as a hard disk. Otherwise, the system performance on this channel may drop.

**(9) Serial-ATA Port connector:**

**SATA1 / SATA2 / SATA3/ SATA4**

This connector support the provided Serial ATA and Serial ATA2(Only for M2GT4-LDG-PB motherboard) IDE hard disk cable to connecting the motherboard and serial ATA hard disk.

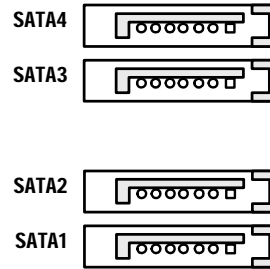

Serial-ATA1 & 2 Compatible Connectors

**3-2 Headers**

**(1) Line-Out/MIC Header for Front Panel (9-pin): AUDIO1**

This header connect to Front Panel Line-out, MIC connector with cable. Without install the cable, this header default setting is 5-6 short, 9-10 short. When you install the cable you have take off these jumpers.

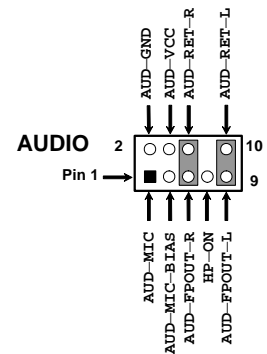

Line-Out, MIC Headers

**(2) USB Port Headers (9-pin) :**

**USB1(USB4) / USB2 / USB3**

These headers are used for connecting the additional USB port plug. By attaching an option USB cable, your can be provided with two additional USB plugs affixed to the back panel.

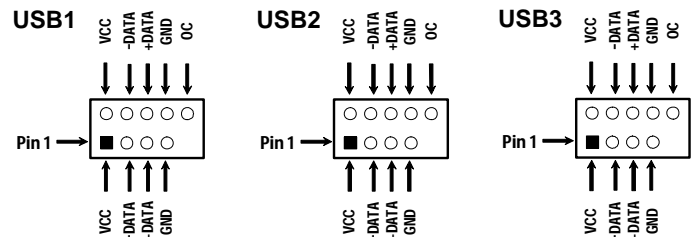

USB Port Headers

**(3) Speaker connector: SPEAK1**

This 4-pin connector connects to the case-mounted speaker. See the figure below.

**(4) Power LED: PWR LED1**

The Power LED is light on while the system power is on. Connect the Power LED from the system case to this pin.

**(5) IDE Activity LED: HD LED**

This connector connects to the hard disk activity indicator light on the case.

**(6) Reset switch lead: RESET**

This 2-pin connector connects to the case-mounted reset switch for rebooting your computer without having to turn off your power switch. This is a preferred method of rebooting in order to prolong the life of the system's power supply. See the figure below.

**(7) Power switch: PWR BTN**

This 2-pin connector connects to the case-mounted power switch to power ON/OFF the system.

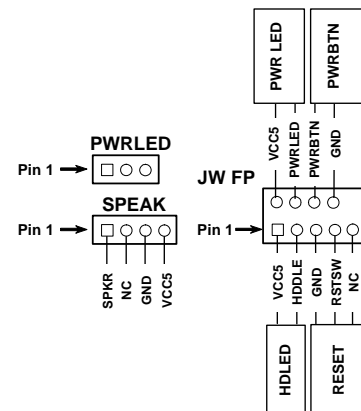

System Case Connections

**(8) FAN Power Headers: CHAFAN1, CHAFAN2 / SYSFAN1, SYSFAN2 (3-pin),**

**CPUFAN (4-pin)**

These connectors support cooling fans of 350mA (4.2 Watts) or less, depending on the fan manufacturer, the wire and plug may be different. The red wire should be positive, while the black should be ground. Connect the fan's plug to the board taking into consideration the polarity of connector.

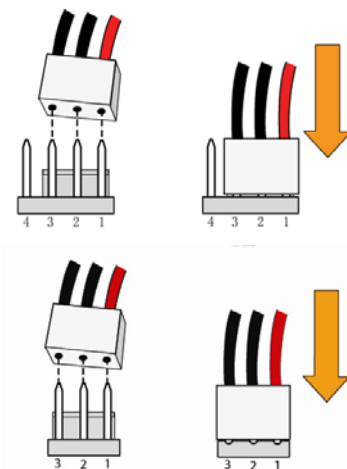
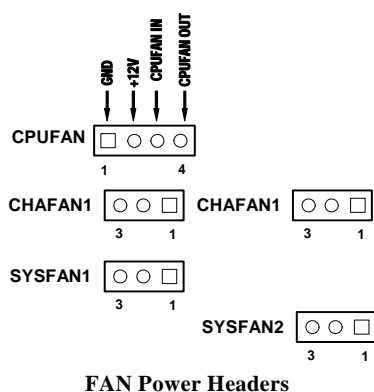

---

---

**(9) CD Audio-In Headers (4-pin) : CDIN**

CDIN are the connectors for CD-Audio Input signal. Please connect it to CD-ROM CD-Audio output connector.

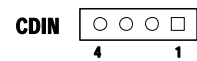

**CD Audio-In Headers**

**(10) IR infrared module Headers (5-pin) : IR1**

This connector supports the optional wireless transmitting and receiving infrared module. You must configure the setting through the BIOS setup to use the IR function.

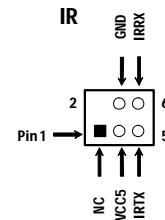

**IR infrared module Headers**

**(11) Parallel Port Connector (25-pin female): PARALLEL1**

The On-board Parallel Port can be disabled through the BIOS SETUP. Please refer to Chapter 3 “INTEGRATED PERIPHERALS SETUP” section for more detail information.

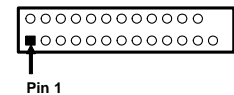

**PARALLEL Connector**

**(12) Serial COM Port: COM1**

COM1 is the 9-pin block pin-header. The On-board serial port can be disabled through BIOS SETUP. Please refer to Chapter 3 “INTEGRATED PERIPHERALS SETUP” section for more detail information

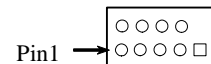

**Serial COM Port 9-pin Block**

**(13) SPDIF In/Out header: SPDIF**

The SPDIF output is capable of providing digital audio to external speakers or compressed AC3 data to an external Dolby digital decoder. Use this feature only when your stereo system has digital input function. Use SPDIF IN feature only when your device has digital output function.

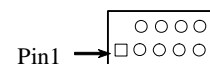

**SPDIF Conn. 9-pin Block**



---

---

## Chapter 4

### USEFUL HELP

#### 4-1 HOW TO UPDATE BIOS

Before updating the BIOS, users have to “Disable” the “Flash Part Write Protect” selection in “Miscellaneous Control” of BIOS SETUP. Otherwise the system will not allow you to upgrade BIOS by Award Flash Utility.

**STEP 1.** Prepare a boot disc. (you may make one by click START click RUN type SYS A:click OK)

**STEP 2.** Copy utility program to your boot disc. You may copy from DRIVER CD  
X:\FLASH\AWDFLASH.EXE or download from our web site.

**STEP 3.** Download and make a copy of the latest BIOS for **AMD480X** PPC motherboard series from the web site to your boot disc.

**STEP 4.** Insert your boot disc into A:;

start the computer, type “Awdflash A:\ **AMD480X**.BIN /SN/PY/CC/R”

**AMD480X xxx**.BIN is the file name of latest BIOS it can be **AMD480X**.BIN or **AMD480X**.BIN

SN means don't save existing BIOS data

PY means renew existing BIOS data

CC means clear existing CMOS data

R means restart computer

**STEP 5.** Push ENTER to update and flash the BIOS, then the system will restart automatically.

#### 4-2 Trouble Shooting

Problem	Solution
No power to the system to the all power light don't illuminate, fan inside power supply doesn't turn on.	1. Make sure power cable is security plugged in. 2. Replace cable. 3. Contact technical support.
System inoperative. Keyboard lights are on , power indicator lights are lit, and hard drive is spinning.	Using ever pressure on both ends of the DIMM , press down firmly until the module snaps into places.
System doesn't boot from hard disk drive, can be booted from optical drive.	1. Check cable running from disk to disk controller board. .Make sure both ends are securely plugged in, check the drive type in the standard CMOS setup. 2. Backing up the hard drive is extremely important .All hard disks are capable of breaking down at any time.
System only boots from optical drive .Hard disk can be read and applications can be used but booting from hard disk is impossible.	1. Back up date and applications files. 2. Reformat the hard drive. Reinstall applications and date using backup disks.
Screen message says “Invalid Configuration” or “CMOS Failure”	Review system 's equipment .Make sure correct information on is in setup.
Can not boot system after installing second hard drive.	1. Set master /slave jumpers correctly. 2. Run SETUP program and select correct drive types. Call the drive manufacture for compatibility with other drives.

---

---

## 4-3 The Introduction of DIY COOL Function

### Advanced Thermal Solution System for PWM (The active cooling fan is Optional)

“DIY COOL” function is the unique thermal solution for PWM. The special and cost-effective design can be the exhaust valve of exhausting the heat generated by PWM effectively. With the small but quiet active 55mm cooling fan to decrease the temperature of PWM, we can extend the MTBF of the capacitors up to 30% and get more stability of the system working under the higher and higher frequency in the future.

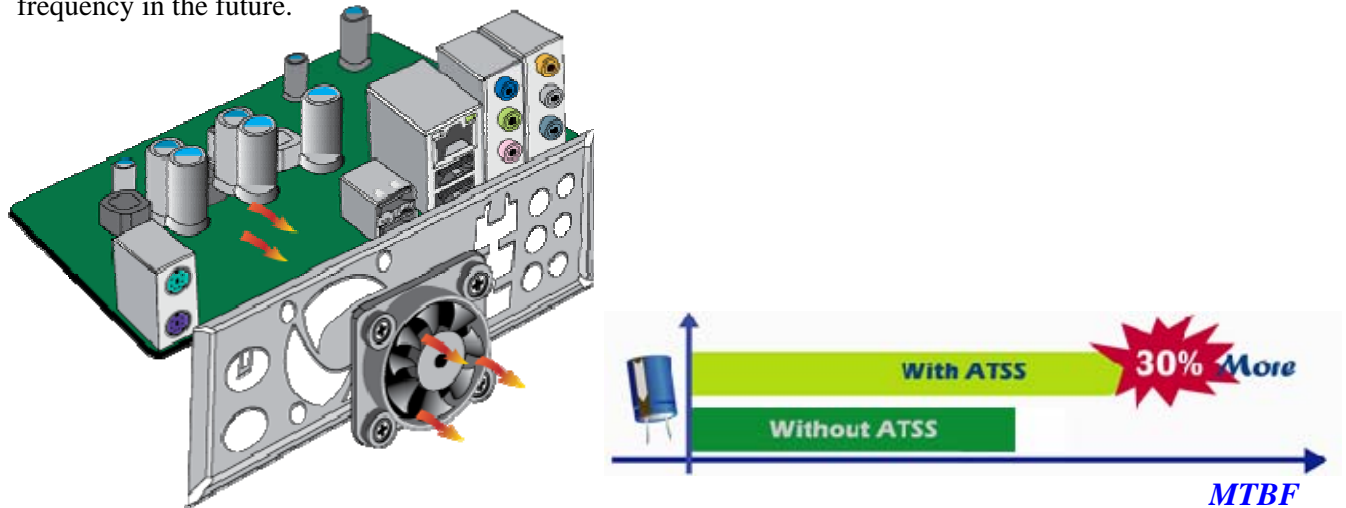

## 4-4 The Introduction of BIOS BACK Function

### Advanced BIOS Back & Recovery Function

“BIOS Back” function is automatically activated when the original BIOS malfunction occurs. When it occurs to BIOS malfunction, the BIOS BACK function will be activated automatically, then the system will restart to reload the BIOS backup to the system boot up menu as the following figure. It takes 4 to 8 seconds to get into the boot up menu and here comes the message, “Warning! Now System is BACKUP BIOS. Please reflash primary BIOS.” after system reboots. And then, please follow the OSD to press “F1” button to continue to log on your operation system.

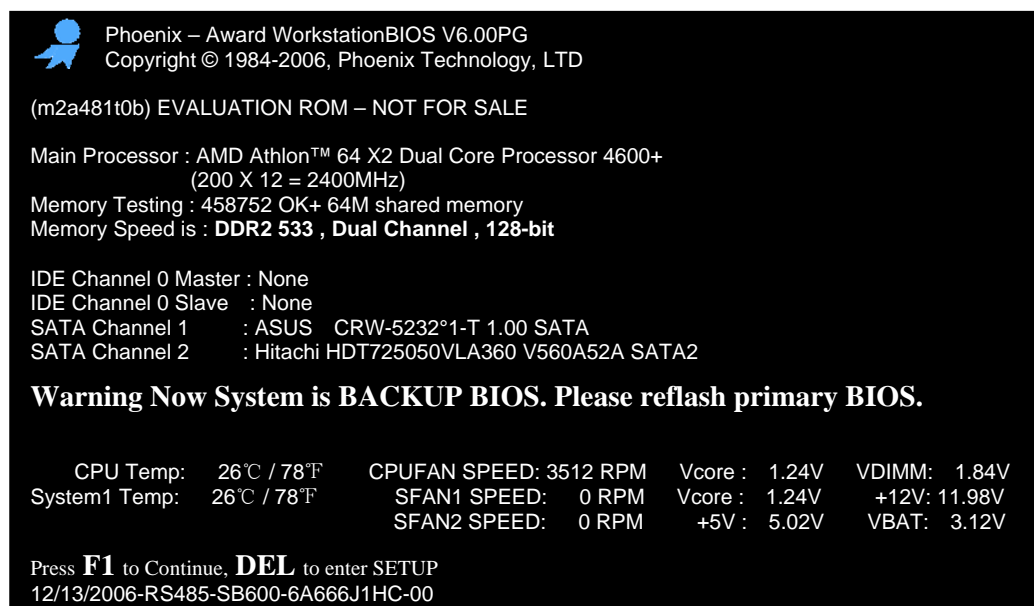

Please make sure to Update the BIOS after getting into operation system, or the BIOS BACK function will check your primary BIOS status every time, and it may cause your inconvenience to.