

**SYSTEMBAUGRUPPE D1131**  
**SYSTEM BOARD D1131**

---

*TECHNISCHES HANDBUCH*  
*TECHNICAL MANUAL*

## Sie haben ...

... technische Fragen oder Probleme?

Wenden Sie sich bitte an:

- einen unserer Servicepartner
- Ihren zuständigen Vertriebspartner
- Ihre Verkaufsstelle

Die Adressen Ihrer Servicepartner finden Sie im Garantieheft oder im Service-Adressenheft.

Aktuelle Informationen zu unseren Produkten, Tipps, Updates usw. finden Sie im Internet:

*<http://www.fujitsu-siemens.com>*

## Is there ...

... any technical problem or other question you need clarified?

Please contact:

- one of our service partners
- your sales partner
- your sales outlet

The addresses of your service partners are contained in the guarantee booklet or in the service address booklet.

The latest information on our products, tips, updates, etc., can be found on the Internet under:

*<http://www.fujitsu-siemens.com>*





Dieses Handbuch wurde auf Recycling-Papier gedruckt.  
This manual has been printed on recycled paper.  
Ce manuel est imprimé sur du papier recyclé.  
Este manual ha sido impreso sobre papel reciclado.  
Questo manuale è stato stampato su carta da riciclaggio.  
Denna handbok är tryckt på recyclingpapper.  
Dit handboek werd op recycling-papier gedrukt.

Herausgegeben von/Published by  
Fujitsu Siemens Computers GmbH

Bestell-Nr./Order No.: **A26361-D1131-Z120-1-7419**

Printed in the Federal Republic of Germany

AG 0100 01/00

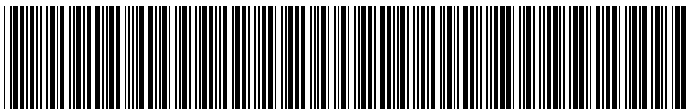

A26361-D1131-Z120-1-7419

Deutsch

English

**Systembaugruppe  
D1131  
System Board D1131**

**Technisches Handbuch  
Technical Manual**

**Ausgabe Januar 2000  
January 2000 edition**

Copyright © Fujitsu Siemens Computers GmbH 2000

Intel, Pentium und Celeron sind eingetragene Warenzeichen und MMX und OverDrive sind Warenzeichen der Intel Corporation, USA.

Microsoft, MS, MS-DOS und Windows sind eingetragene Warenzeichen der Microsoft Corporation.

PS/2 und OS/2 Warp sind eingetragene Warenzeichen von International Business Machines, Inc.

Alle weiteren genannten Warenzeichen sind Warenzeichen oder eingetragene Warenzeichen der jeweiligen Inhaber und werden als geschützt anerkannt.

Alle Rechte vorbehalten, insbesondere (auch auszugsweise) die der Übersetzung, des Nachdrucks, der Wiedergabe durch Kopieren oder ähnliche Verfahren.

Zu widerhandlungen verpflichten zu Schadenersatz.

Alle Rechte vorbehalten, insbesondere für den Fall der Patenterteilung oder GM-Eintragung.

Liefermöglichkeiten und technische Änderungen vorbehalten.

Intel, Pentium and Celeron are registered trademarks and MMX and OverDrive are trademarks of Intel Corporation, USA.

Microsoft, MS, MS-DOS and Windows are registered trademarks of Microsoft Corporation.

PS/2 and OS/2 Warp are registered trademarks of International Business Machines, Inc.

All other trademarks referenced are trademarks or registered trademarks of their respective owners, whose protected rights are acknowledged.

All rights, including rights of translation, reproduction by printing, copying or similar methods, even of parts are reserved.

Offenders will be liable for damages.

All rights, including rights created by patent grant or registration of a utility model or design, are reserved. Delivery subject to availability.

Right of technical modification reserved.

---

# Contents

Introduction.....	1
Notational conventions .....	1
Important notes .....	1
Information on boards.....	2
Features .....	3
Interfaces and connectors .....	4
Resource table .....	6
PCI bus interrupts.....	6
Settings with switches .....	7
Recovering System BIOS - switch 2 .....	8
Write protection for floppy disks - switch 3 .....	8
Add-on modules .....	9
Installing / removing processor .....	10
Upgrading main memory.....	11
Replacing the lithium battery.....	12
Glossary .....	13





---

# Introduction



This system board is available in different configuration levels. Depending on the hardware configuration of your device, it may be that you cannot find several options in your version of the system board, even though they are described.

You may find further information in the description "BIOS Setup".

Further information to drivers is provided in the readme files on hard disk or on the supplied drivers diskettes or on the "Drivers & Utilities" or "ServerStart" CD.

## Notational conventions

The meanings of the symbols and fonts used in this manual are as follows:



Pay particular attention to texts marked with this symbol. Failure to observe this warning endangers your life, destroys the system, or may lead to loss of data.



Supplementary information, remarks and tips follow this symbol.

- ▶ Texts which follow this symbol describe activities that must be performed in the order shown.
- ␣ This symbol means that you must enter a blank space at this point.
- ☑ This symbol means that you must press the Enter key.

Texts in this typeface are screen outputs.

Texts in this bold typeface are the entries you make via the keyboard.

Texts in italics indicate commands or menu items.

"Quotation marks" indicate names of chapters and terms that are being emphasized.

## Important notes

Store this manual close to the device. If you pass on the device to third parties, you should also pass on this manual.



Be sure to read this page carefully and note the information before you open the device. You cannot access the components of the system board without first opening the device. How to dismantle and reassemble the device is described in the Operating Manual accompanying the device.

Please note the information provided in the chapter "Safety" in the Operating Manual of the device.

Incorrect replacement of the lithium battery may lead to a risk of explosion. It is therefore essential to observe the instructions in the chapter "[Add-on modules](#)" - "[Replacing the lithium battery](#)".



The shipped version of this board complies with the requirements of the EEC directive 89/336/EEC "Electromagnetic compatibility".

Compliance was tested in a typical PC configuration.

When installing the board, refer to the specific installation information in the Operating Manual or Technical Manual of the receiving device.

Connecting cables for peripherals must be adequately insulated to avoid interference.



Components can become very hot during operation. Make sure you do not touch components when making extensions to the system board. There is a danger of burns!



The warranty is invalidated if the device is damaged during the installation or replacement of system expansions. Information on which system expansions you can use is available from your sales outlet or the customer service center.

## Information on boards

To prevent damage to the system board or the components and conductors on it, please take great care when you insert or remove boards. Take care above all to ensure that extension boards are slotted in straight without damaging components or conductors on the system board, or any other components, for example EMI spring contacts.

Be especially careful with the locking mechanisms (catches, centering pins etc.) when you replace the system board or components on it, for example memory modules or processors.

Never use sharp objects (screwdrivers) for leverage.



Boards with electrostatic sensitive devices (ESD) are identifiable by the label shown.

When you handle boards fitted with ESDs, you must observe the following points under all circumstances:

- You must always discharge yourself (e.g. by touching a grounded object) before working.
- The equipment and tools you use must be free of static charges.
- Pull out the power plug before inserting or pulling out boards containing ESDs.
- Always hold boards with ESDs by their edges.
- Never touch pins or conductors on boards fitted with ESDs.

---

# Features

The components and connectors marked do not have to be present on the system board.

- System board in micro ATX format
- Intel Celeron processor with 66 MHz Front Side Bus for PGA 370 socket

Intel Celeron processors support MMX technology. Size and frequency of first-level cache and second-level cache are depending on the processor used.

- Intel chipset 440ZX / PIIX4E
- 2 DIMM slots for 16 to 256 Mbyte main memory (SDRAM memory modules)
- Flash BIOS
- Energy saving functions: ACPI and APM.
- Security functions: System, setup- and keyboard password, parallel and serial interfaces can be disabled, write protection for floppy disk drive, virus warning for boot hard disk, virus protection function for the flash BIOS and the EEPROMs on the memory modules.
- 1 AGP slot, 2 PCI slots, 1 ISA/PCI slot (shared)  
AGP and PCI slots support 3.3 V main voltage.
- IDE hard disk controller connected to PCI bus for up to four IDE drives  
(e.g. IDE hard disk drives, ATAPI CD-ROM drives)  
The IDE hard disk controller are ultra DMA33 mode capable and support PIO modes 0-4.
- Floppy disk drive controller (possible formats: 720 Kbyte, 1.44 Mbyte, 2.88 Mbyte)
- The system board supports booting from a 120 Mbyte IDE floppy disk drive.
- 1 external parallel interface (ECP- and EPP-compatible)
- 1 external serial port (16C550 compatible with FIFO)
- 1 internal serial port (16C550 compatible with FIFO)  
This port does not support the ring indicator signal.
- 1 internal WOL interface
- 2 external PS/2 interfaces for keyboard and mouse
- 2 external USB ports (USB = Universal Serial Bus)
- Real-time clock/calendar with integrated battery backup

## Interfaces and connectors

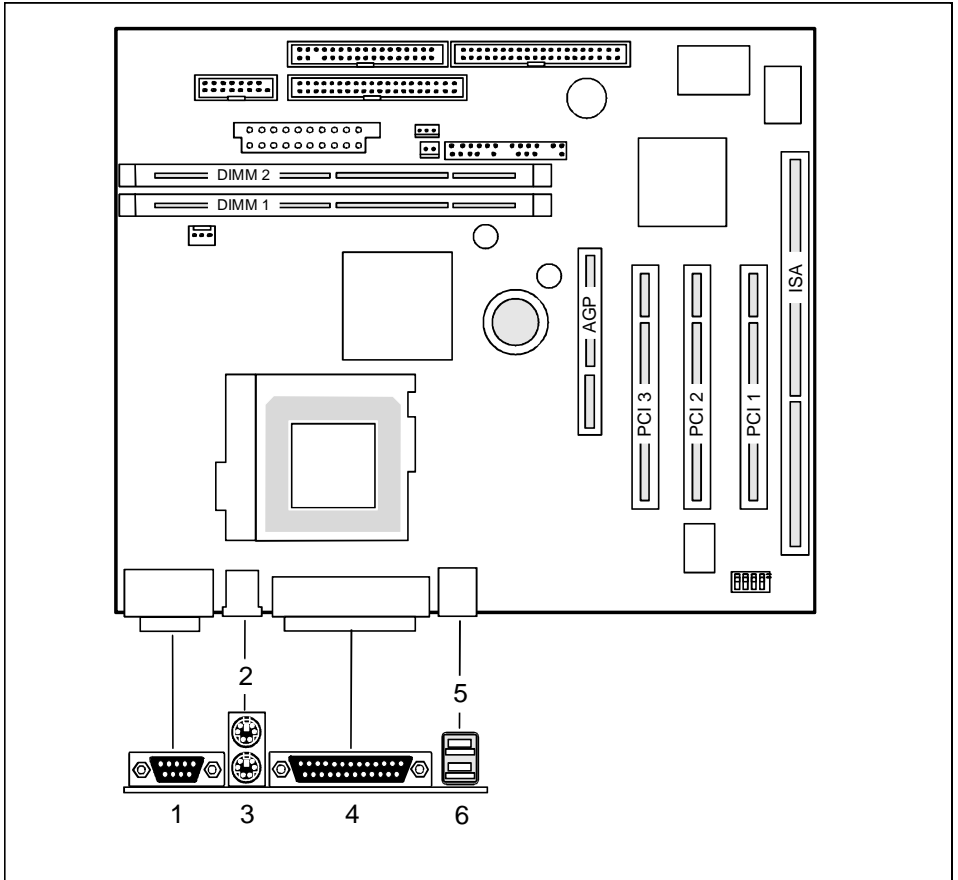

- 1 = Serial port 1
- 2 = PS/2 mouse port
- 3 = PS/2 keyboard port

- 4 = Parallel port
- 5 = USB port 2
- 6 = USB port 1

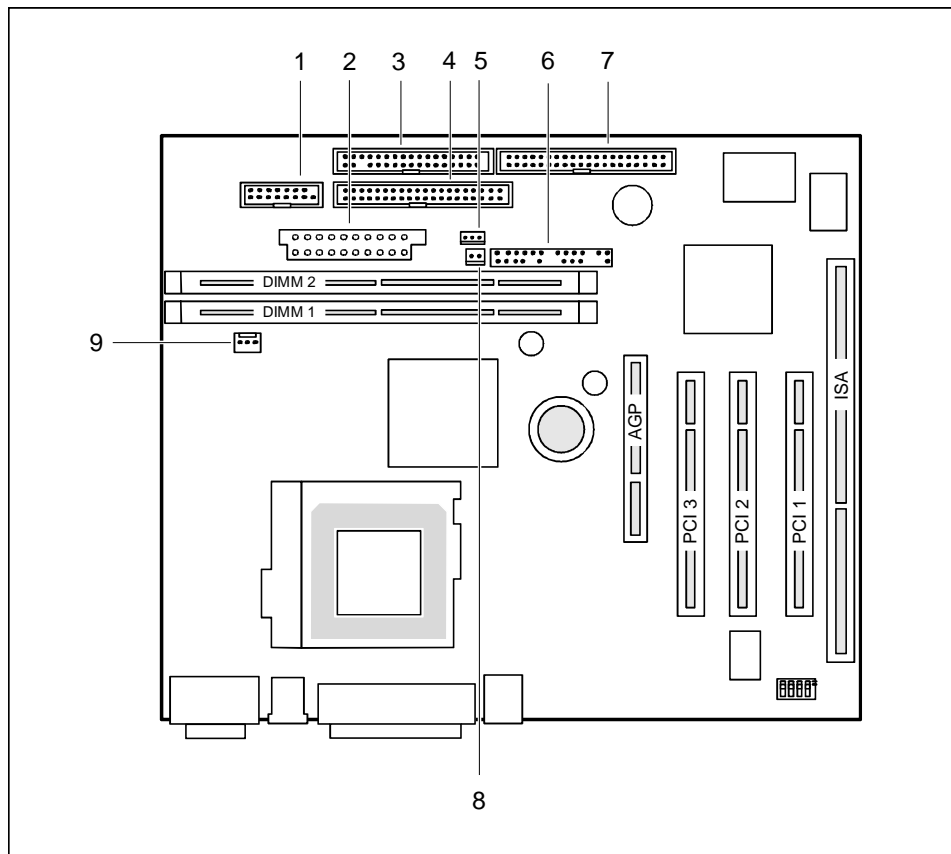

- |   |                                   |
|---|-----------------------------------|
| 1 = Serial chipcard reader interface or serial port 2 | 6 = Connector for front panel     |
| 2 = Power supply                                      | 7 = IDE drives 1 and 2 (primary)  |
| 3 = Floppy disk drive                                 | 8 = ON/OFF switch                 |
| 4 = IDE drives 3 and 4 (secondary)                    | 9 = Fan (e. g. for the processor) |
| 5 = Wake On LAN                                       |                                   |

The components and connectors marked do not have to be present on the system board.

## Resource table

	assigned IRQ	possible IRQ	Possible Address (hex)	Possible DMA
Keyboard	IRQ1			
Serial interface COM1		3 4	03F8, 02F8 03E8, 02E8	
Serial port COM2		3 4	02E8, 02F8 03E8, 03F8	
Floppy disk drive controller	IRQ6			2
Parallel interface LPT1		5, 7	0278, 0378, 03BC	0, 1, 3
RTC	IRQ8			
USB controller			PnP	
Mouse controller	IRQ12			
Numeric processor	IRQ13			
IDE controller 1	IRQ14		01F0-01F7	
IDE controller 2	IRQ15		0170-0177	

"assigned IRQ" = interrupts assigned as shipped

"Possible IRQ" = these interrupts can be used for your particular application

"Possible address" = this address can be used for your particular application

"Possible DMA" = these DMAs can be used for your particular application

## PCI bus interrupts

The following table shows which PCI bus interrupts on the system board are assigned.

PCI bus interrupt	Component on system board:
A	PCI bus slot 1
A	AGP slot
B	PCI bus slot 2
C	PCI bus slot 3
D	USB controller

## Settings with switches

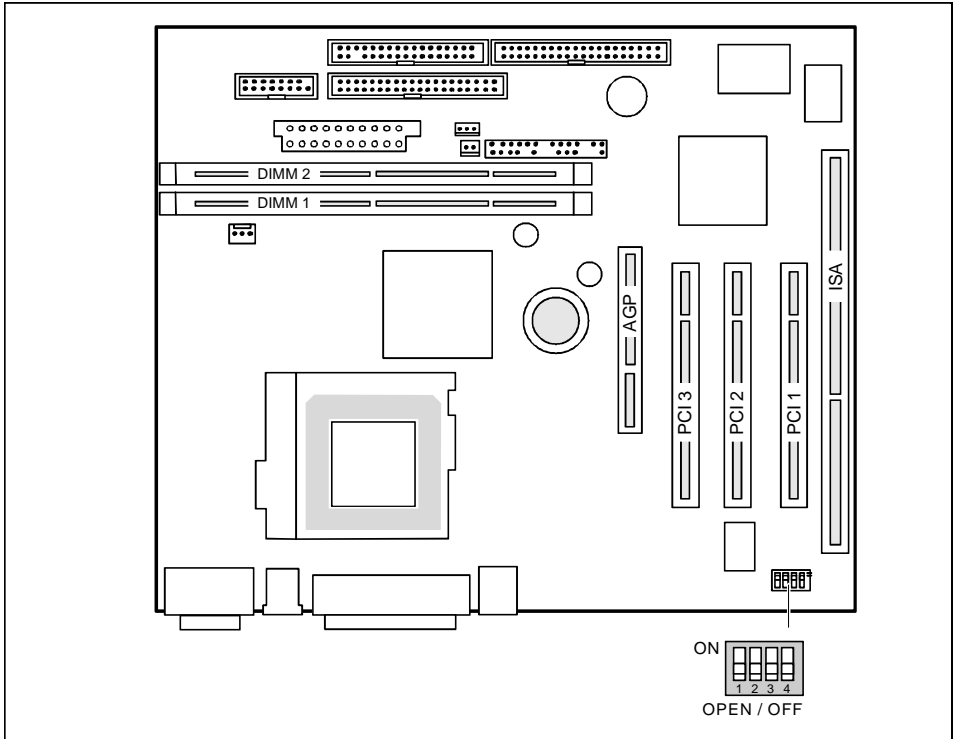

Switch 1 = must be set to *off*  
 Switch 2 = System BIOS recovery (RCV)

Switch 3 = Write protection for floppy disks

Switch 4 = reserved



The clock frequency of the processor is set automatically.

## Recovering System BIOS - switch 2

Switch RCV enables recovery of the old system BIOS after an attempt to update has failed. To restore the old system BIOS you need a Flash BIOS Diskette (please call our customer service center).

*On*                    The System BIOS executes from floppy drive A: and the inserted "Flash-BIOS-Diskette" restores the System BIOS on the system board.

*Off*                    Normal operation (default setting).

## Write protection for floppy disks - switch 3

Switch 3 is used to define whether floppy disks can be written or deleted in the floppy disk drive. To write and delete floppy disks, the write-protection in *BIOS Setup* must be disabled (in menu *Security*, the field *Diskette Write* must be set to *Enabled*).

*On*                    The floppy disk drive is write-protected.

*Off*                    Read, write and delete floppy disks is possible (default setting).



## Add-on modules



For all steps described in this chapter pull the power plug out of the power outlet!  
Even when you have run down the device, parts of the device (e. g. memory modules, AGP and PCI extension boards) are still energized.

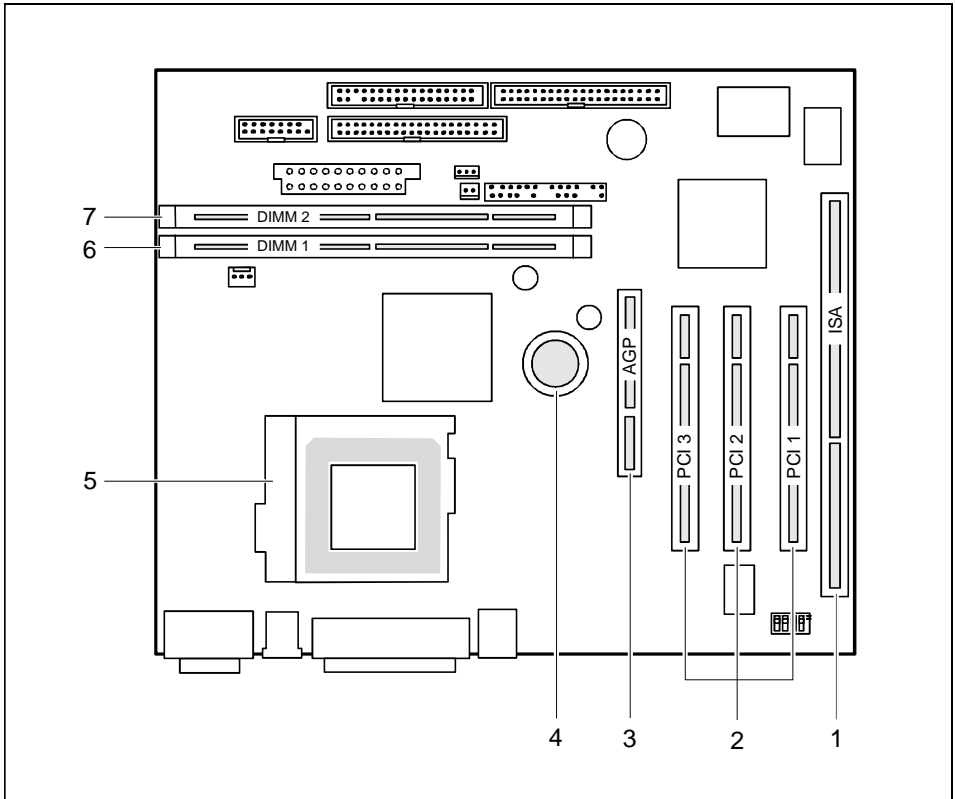

- |                       |                                       |
|-----------------------|---------------------------------------|
| 1 = ISA slot          | 5 = Slot for processor with heat sink |
| 2 = PCI slots 1, 2, 3 | 6 = Location bank 1 for main memory   |
| 3 = AGP slot          | 7 = Location bank 2 for main memory   |
| 4 = Lithium battery   |                                       |



All PCI slots have bus master capability and support 3.3 V.

## Installing / removing processor

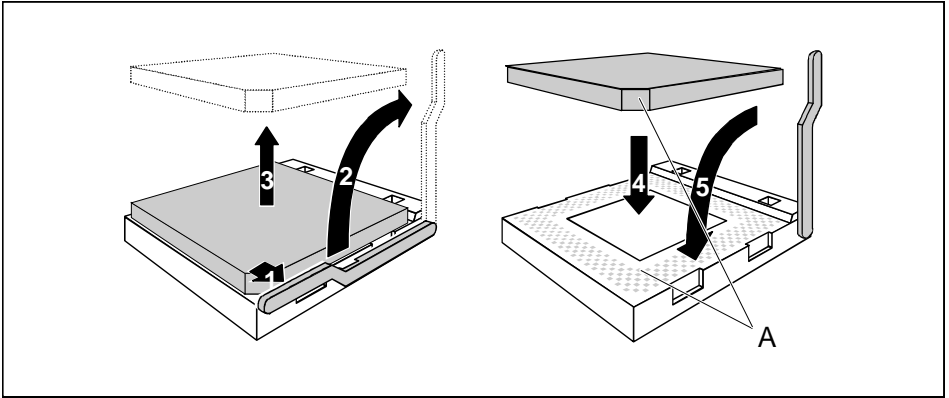

The heat sink is mounted on the processor with a clip.

- ▶ Lift the heat sink off the processor.
- ▶ Push the lever in the direction of the arrow (1) and lift it as far as it will go (2).
- ▶ Remove the old processor from the socket (3).
- ▶ Insert the new processor in the socket so that the angled corner of the processor matches the coding on the socket (A) with regard to the position (4).



The angled corner of the processor may be covered by the heat sink. In this case let yourself be guided by the marking in the rows of pins on the underside of the processor.

- ▶ Push the lever back down so that it snaps into place.

## Upgrading main memory

These slots are suitable for 16, 32, 64 and 128 Mbyte memory modules of the DIMM format. Memory modules with different memory capacities can be combined.

DIMM = Dual Inline Memory Module

SDRAM = Synchronous Dynamic Random Access Memory



You may only use unbuffered 3.3V memory modules. Buffered memory modules are not permitted.

SDRAM memory modules must be designed for a clock frequency of 66 MHz or higher (meets PC100 specification).

### Installing memory modules

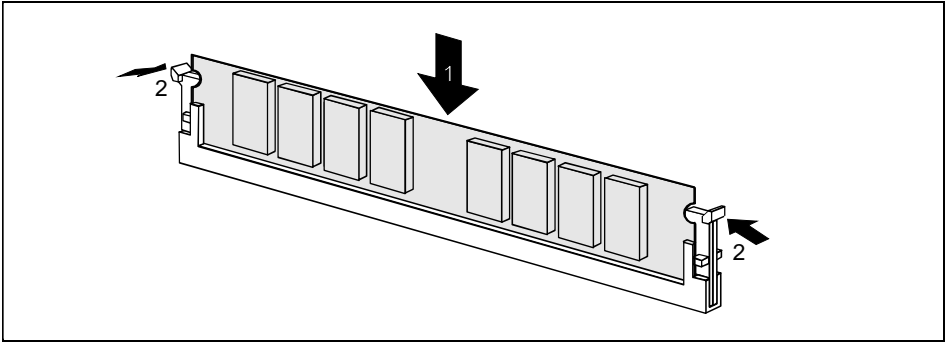

- ▶ Flip the holders on each side of the relevant location outwards.
- ▶ Insert the memory module into the location.

Watch the coding of the memory module when doing so.

- ▶ At the same time flip the lateral holders upwards until the memory module snaps in place.

### Removing a memory module

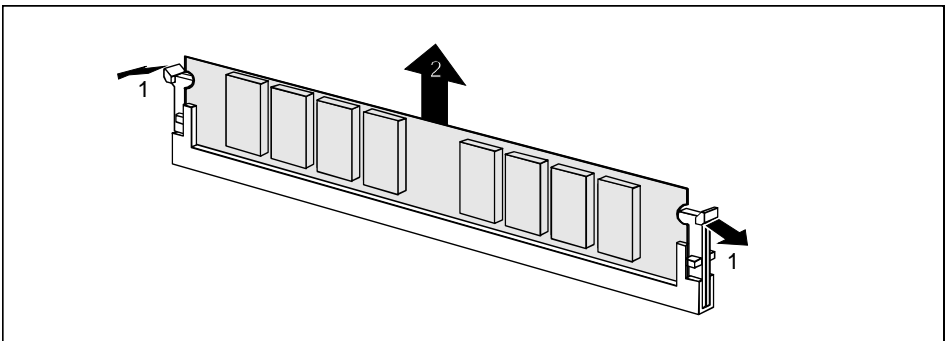

- ▶ Flip the holders to the right and left of the location outwards.
- ▶ Pull the memory module out of its location.

## Replacing the lithium battery



Incorrect replacement of the lithium battery may lead to a risk of explosion.

The lithium battery must be replaced with an identical battery or a battery type recommended by the manufacturer (CR2032).

Do not throw lithium batteries into the trashcan. It must be disposed of in accordance with local regulations concerning special waste.

Make sure that you insert the battery the right way round. The plus pole must be on the top!

- **VAROITUS**  
Paristo voi räjähtää, jos se on virheellisesti asennettu. Vaihda paristo ainoastaan laitevalmistajan suosittelemaan tyyppiin. Hävitä käytetty paristo valmistajan ohjeiden mukaisesti.
- **VARNING**  
Explosionsfara vid felaktigt batteribyte. Använd samma batterityp eller en ekvivalent typ som rekommenderas av apparattillverkaren. Kassera använt batteri enligt fabrikantens instruktion.
- **ADVARSEL**  
Lithiumbatteri - Explosionsfare ved fejlagtig håndtering. Udskiftning må kun ske med batteri af samme fabrikat og type. Lever det brugte batteri tilbage til leverandøren.
- **ADVARSEL**  
Explosionsfare ved feilaktig skifte av batteri. Benytt samme batteritype eller en tilsvarende type anbefalt av apparatfabrikanten. Brukte batterier kasseres i henhold til fabrikantens instruksjoner.

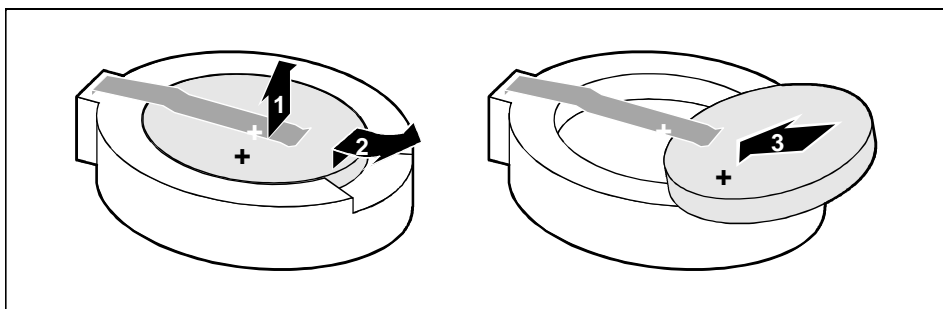

- ▶ Lift the contact (1) a few millimeters and remove the battery from its socket (2).
- ▶ Insert a new lithium battery of the same type in the socket (3).

## Glossary

The technical terms and abbreviations given below represent only a selection of the full list of common technical terms and abbreviations.

Not all technical terms and abbreviations listed here are valid for the described system board.

ACPI.....	Advanced Configuration and Power Interface
AC'97 .....	Audio Codec '97
AGP .....	Accelerated Graphics Port
AMR .....	Audio Modem Riser
AOL.....	Alert On LAN
APM .....	Advanced Power Management
ATA .....	Advanced Technology Attachment
BIOS .....	Basic Input Output System
CAN.....	Controller Area Network
CPU.....	Central Processing Unit
C-RIMM.....	Continuity Rambus Inline Memory Module
DIMM.....	Dual Inline Memory Module
ECC.....	Error Correcting Code
EEPROM.....	Electrical Erasable Programmable Read Only Memory
FDC.....	Floppy Disk Controller
FIFO.....	First-In First-Out
FSB .....	Front Side Bus
FWH.....	Firmware Hub
GMCH .....	Graphics and Memory Controller Hub
I <sup>2</sup> C .....	Inter Integrated Circuit
IAPC.....	Instantly Available Power Managed Desktop PC Design
ICH.....	I/O Controller Hub
IDE .....	Intelligent Drive Electronics
IPSEC .....	Internet Protocol Security
ISA .....	Industrial Standard Architecture
LAN .....	Local Area Network
LSA .....	LAN Desk Service Agent
MCH.....	Memory Controller Hub
MMX.....	MultiMedia eXtension
PCI .....	Peripheral Component Interconnect
PXE .....	Preboot eXecution Environment
RAM .....	Random Access Memory
RAMDAC.....	Random Access Memory Digital Analog Converter
RDRAM.....	Rambus Dynamic Random Access Memory
RIMM.....	Rambus Inline Memory Module
RTC.....	Real Time Clock
SB .....	Soundblaster
SDRAM .....	Synchronous Dynamic Random Access Memory
SGRAM.....	Synchronous Graphic Random Access Memory
SMBus.....	System Management Bus
SVGA .....	Super Video Graphic Adapter
USB.....	Universal Serial Bus
VGA .....	Video Graphic Adapter
WOL.....	Wake On LAN