

SYSTEM BOARD D1127

*ADDITIONAL TECHNICAL
MANUAL*

Is there ...

... any technical problem or other question you need clarified?

Please contact:

- Our Hotline:
 - Mo-Fr: 8 a.m. - 6 p.m.
 - Sat: 9 a.m. - 2 p.m.
 - Tel.: ++49 (0) 180 3777 005
- your sales outlet

The latest information on our products, tips, updates, etc., can be found on the Internet under:
<http://www.fujitsu-siemens.com>



Dieses Handbuch wurde auf Recycling-Papier gedruckt.
This manual has been printed on recycled paper.
Ce manuel est imprimé sur du papier recyclé.
Este manual ha sido impreso sobre papel reciclado.
Questo manuale è stato stampato su carta da riciclaggio.
Denna handbok är tryckt på recyclingpapper.
Dit handboek werd op recycling-papier gedrukt.

Herausgegeben von/Published by
Fujitsu Siemens Computers GmbH

Bestell-Nr./Order No.: **A26361-D1127-Z180-8-7619**

Printed in the Federal Republic of Germany

AG 0100 01/00

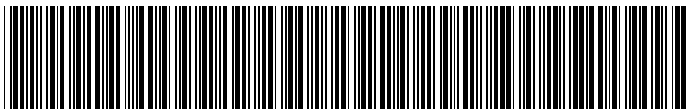

A26361-D1127-Z180-1-7619

English

System Board D1127

Additional Technical Manual

January 2000 edition

Copyright © Fujitsu Siemens Computers GmbH 2000

Intel, Pentium and Celeron are registered trademarks and MMX and OverDrive are trademarks of Intel Corporation, USA.

Microsoft, MS, MS-DOS and Windows are registered trademarks of Microsoft Corporation.

PS/2 and OS/2 Warp are registered trademarks of International Business Machines, Inc.

All other trademarks referenced are trademarks or registered trademarks of their respective owners, whose protected rights are acknowledged.

All rights, including rights of translation, reproduction by printing, copying or similar methods, even of parts are reserved.

Offenders will be liable for damages.

All rights, including rights created by patent grant or registration of a utility model or design, are reserved. Delivery subject to availability.

Right of technical modification reserved.

Contents

Introduction.....	1
Features	2
Mechanics	3
Connectors and Jumpers.....	5
External temperature sensor (LM75) (T26139-Y3718-V1).....	5
Internal chipcard reader or serial port 2 (COM2) (external via optional cable).....	5
Power supply ATX connector.....	6
Front panel connector.....	7
Fan 2.....	7
Wake on LAN (WOL) connector.....	8
I°C connector (for ambient/external temperature sensor) for optional temperature sensor (e.g. LM75).....	8
Auxiliary (MPEG, TV) Audio connector (internal)	8
CD-ROM Audio connector (internal)	9
USB chipcard reader	9
Fan 1	9
Power supply monitoring.....	10
Intrusion connector for case open detect for optional push-button (opener).....	10
Configuration	10
Functions controlled by the switch block	10
Supported ACPI system states	11
ACPI Wakeup Possibilities	11
USB power jumper function description	11
BIOS options	11
Messages	12
Power	12
Power requirement	12
Power loadability.....	12
Documentation	13
Installing drivers	13
Upgrades.....	14
Main memory.....	14
Troubleshooting.....	15
Message BIOS update.....	15
The screen stays blank.....	15

Introduction



This system board is available in different configuration levels. Depending on the hardware configuration of your device, it may be that you cannot find several options in your version of the system board, even though they are described.

You may find further information e. g. in the complete Technical Manual for the system board and in the description "BIOS Setup".

Further information to drivers is provided on the supplied drivers diskettes or on the "Drivers & Utilities" or "ServerStart" CD. For detailed information please look at chapter "[Installing drivers](#)". The latest BIOS version or drivers can be found on the internet under <http://www.siemens.de/computer/service>.

Features

This table shows an assembly version of this system board as example.

Function	Version D1127- -A	Version D1127- -B	Version D1127- -C
Processor socket	Slot 1	Slot 1	Slot 1
Processor	Intel Pentium II or Pentium III	Intel Pentium II or Pentium III	Intel Pentium II or Pentium III
Formfactor	ATX	ATX	ATX
Front Side Bus in MHz	66/100/133	66/100/133	66/100/133
Chipset	i 820	i 820	i 820
Memory sockets	2 RIMM	2 RIMM	2 RIMM
ISA slots	--	--	1
PCI slots	5	5	5
ISA/PCI shared	--	--	--
AGP port	1	1	1
System monitoring	x	x	x
Thermal Management	x	x	x
Wake On LAN	x	x	x
Keyboard On	x	x	x
IrDA			
Chipcard reader	x	x	x
Save to Disk (ACPI S4)	x	x	x
Save to RAM(ACPI S3)	x	x	x
LAN onboard	x	--	--
Audio onboard	AD 1881	AD 1881	AD 1881
VGA onboard	--	--	--
4MB Display Cache	--	--	--



Computer system boards and components contain very delicate IC chips. To protect them against damage caused from electric static, you have to follow some precautions:

- Unplug your computer when you work inside.
- Hold components by the edge, don't touch their leads.
- Use a grounded wrist strap.

Place the system board and the components on a grounded antistatic pad whenever you work outside the computer.

Once you have installed the system board, you should remove the battery protection (i.e. the thin plastic plate between battery and contact spring).

Mechanics

Layout

ATX 12" x 8" (304,8 mm x 203,2 mm)

Some of the following connectors are optional and may therefore not be included on your system board.

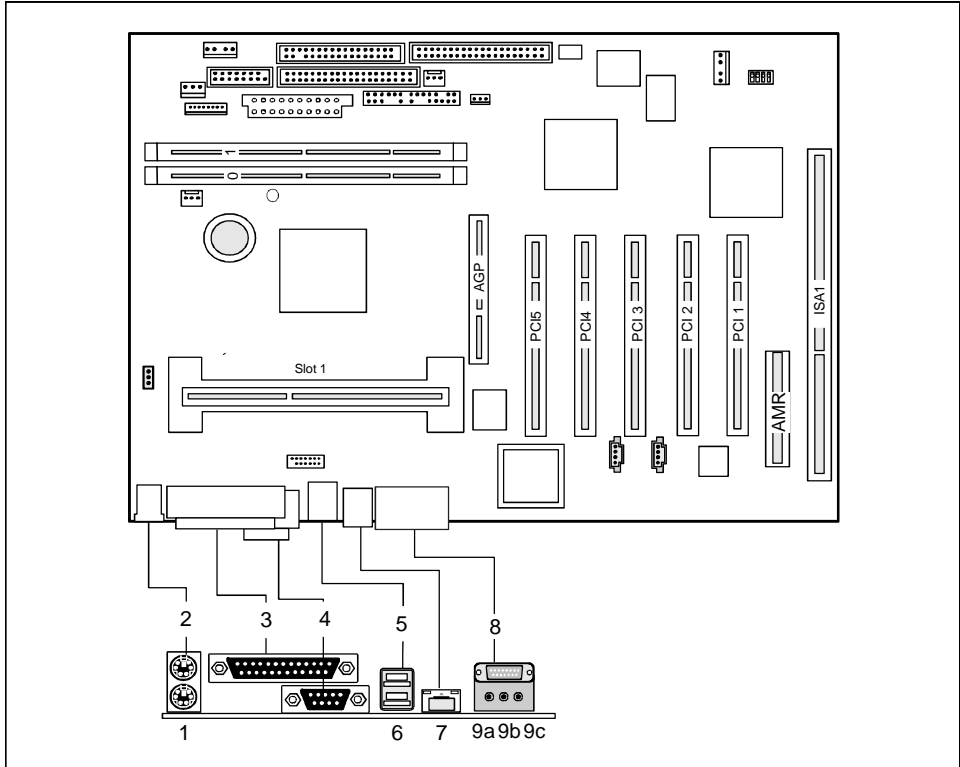

1 = PS/2 keyboard port

2 = PS/2 mouse port

3 = Parallel port

4 = Serial port 1

5 = USB port B

6 = USB port A

7 = LAN port

8 = Game/Midi port

9a = Audio Line-Out

9b = Audio Line-In

9c = Audio Micro-In

The components and connectors marked do not have to be present on the system board.

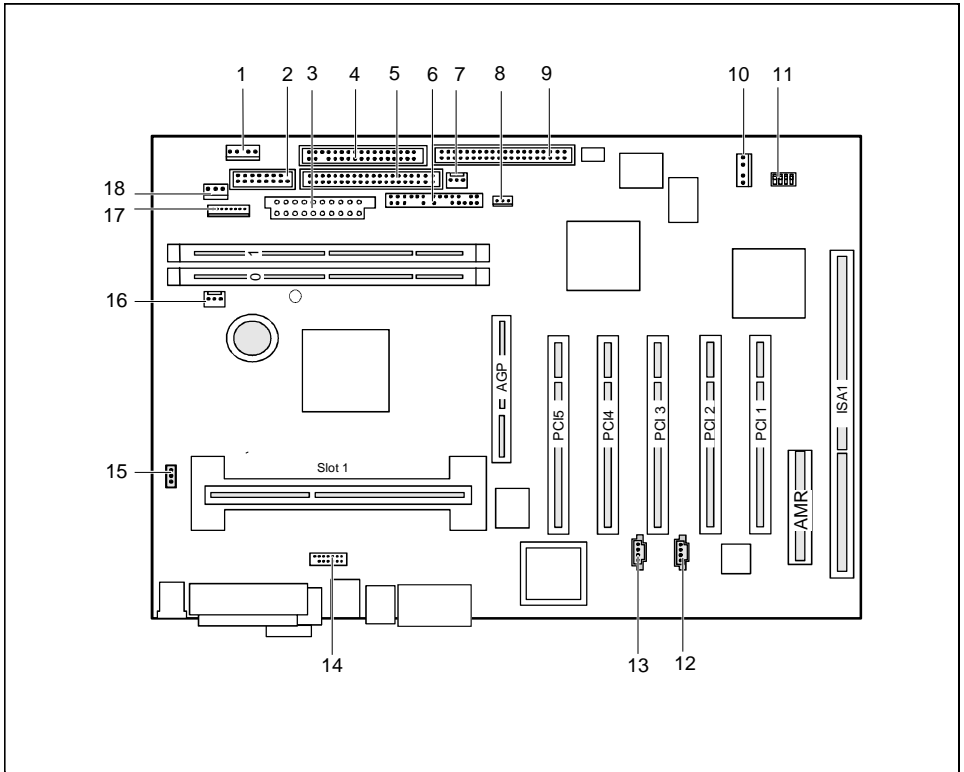

- | | |
|---|--------------------------------------|
| 1 = External temperature sensor | 9 = IDE drives 1 and 2 (primary) |
| 2 = Serial chipcard reader interface or serial port 2 | 10 = I ² C connector |
| 3 = Power supply | 11 = Switch block |
| 4 = Floppy disk drive | 12 = CD-In |
| 5 = IDE drives 3 and 4 (secondary) | 13 = AUX-In |
| 6 = Connector for front panel | 14 = USB chipcard reader |
| 7 = Fan 2 (e. g. for the optional fan (AUX)) | 15 = USB power jumper |
| 8 = Wake On LAN | 16 = Fan 1 (e. g. for the processor) |
| | 17 = Power supply monitoring |
| | 18 = Cover monitoring |

The components and connectors marked do not have to be present on the system board.

Connectors and Jumpers



Some of the following connectors are optional!

External temperature sensor (LM75) (T26139-Y3718-V1)

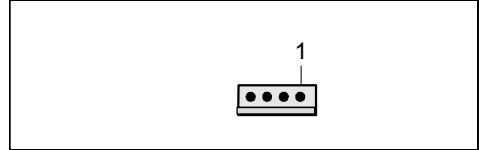

Pin	Signal
1	3.3 V standby
2	Clock
3	Data
4	GND

Internal chipcard reader or serial port 2 (COM2) (external via optional cable)

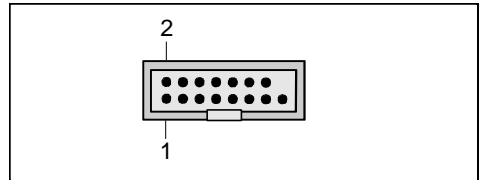

Pin	Signal	Pin	Signal
1	DCD 2 (low asserted)	2	DSR 2 (low asserted)
3	SIN 2 (high asserted)	4	RTS 2 (low asserted)
5	SOULT 2 (high asserted)	6	CTS 2 (low asserted)
7	DTR 2 (low asserted)	8	PC_ON_Strobe
9	GND	10	VCC Auxiliary
11	EXT SMI (low asserted)	12	VCC
13	Not connected	14	GND
15	GND	16	Key

Power supply ATX connector

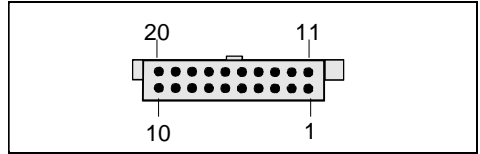

Pin	Signal	Pin	Signal
1	+3.3 V	2	+3.3 V
3	GND	4	+5 V
5	GND	6	+5 V
7	GND	8	Powergood (high asserted)
9	+5 V Auxiliary	10	+12 V
11	+3.3 V	12	-12 V
13	GND	14	PS on (low asserted)
15	GND	16	GND
17	GND	18	-5 V
19	+5 V	20	+5 V

Front panel connector

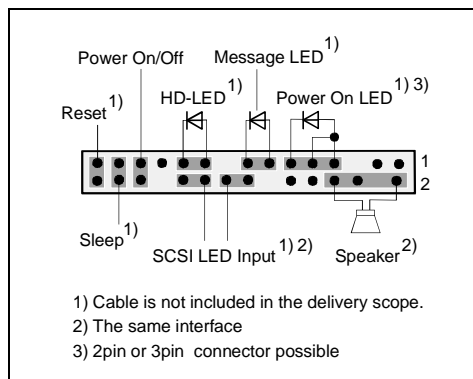

Pin	Signal	Pin	Signal
1	Not connected	2	Speaker
3	Standby LED (Anode)	4	Key
5	Key	6	GND
7	PON_LED (Anode)	8 ¹⁾	VCC or GND
9	PON_LED (Anode)	10	Key pin
11	PON_LED (Cathode/GND) Standby LED (Cathode/GND)	12	Key pin
13	Message LED (Anode)	14	Key
15	Message LED (Cathode)	16	Not connected
17	Key	18	SCSI LED input (low asserted)
19	HD_LED (Anode)	20	SCSI LED input (low asserted)
21	HD_LED (Cathode)	22	Not connected
23	GND	24	Key
25	Power button (low asserted)	26	GND
27 ²⁾	Sleep button (low asserted)	28	GND
29	Reset button (low asserted)	30	GND

- Pin 8 is connected to VCC if audio is not onboard.
Pin 8 is connected to GND if audio is onboard.
- The sleep button (optional) functions only for operating systems with APM (not with ACPI).

Fan 2

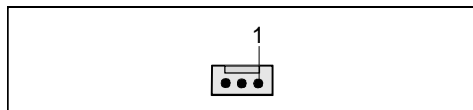

Pin	Signal
1	GND
2	+ 12V
3	FAN sense

Wake on LAN (WOL) connector

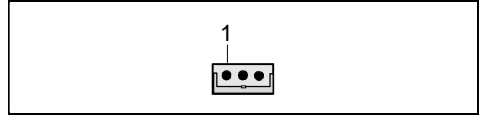

Pin	Signal
1	VCC Auxiliary
2	GND
3	Wake pulse (high asserted)

I²C connector (for ambient/external temperature sensor) for optional temperature sensor (e.g. LM75)

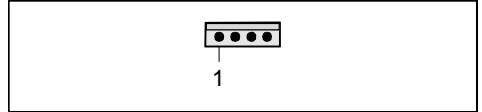

Pin	Signal
1	3.3 V standby
2	Clock
3	Data
4	GND

Auxiliary (MPEG, TV) Audio connector (internal)

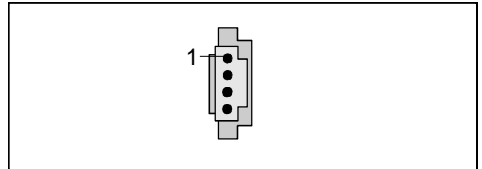

Pin	Signal
1	Left AUX audio input
2	Analog GND
3	Analog GND
4	Right AUX audio input

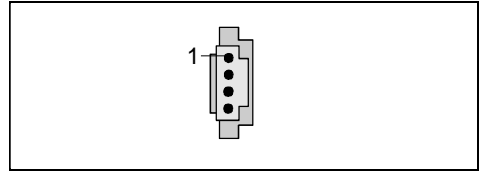
CD-ROM Audio connector (internal)

Pin	Signal
1	Left CD audio input
2	CD GND
3	CD GND
4	Right CD audio input

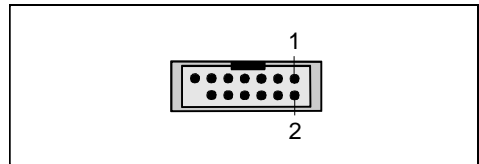
USB chipcard reader

Pin	Signal	Pin	Signal
1	P3V3P_DUAL	2	VCC
3	Data negative up	4	Data positive up
5	Data negative down	6	Data positive down
7	GND	8	GND
9	Chipcard present (high asserted)	10	VCC Auxiliary
11	P3V3P	12	Power OK (low asserted)
13	Chipcard reader On (low pulse)	14	Key

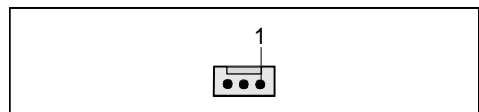
Fan 1

Pin	Signal
1	GND
2	controlled FAN voltage (0 V, 6...12V)
3	FAN sense

Power supply monitoring

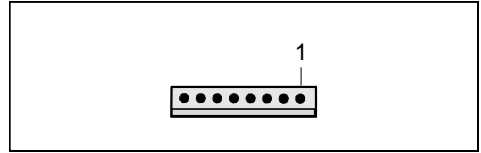

Pin	Signal
1	Monitor on
2	PS FAN off request (low asserted)
3	PS FAN full on (low asserted)
4	PS FAN pulse
5	SMB CLK
6	SMB DATA
7	VCC EEPROM
8	GND

Intrusion connector for case open detect for optional push-button (opener)

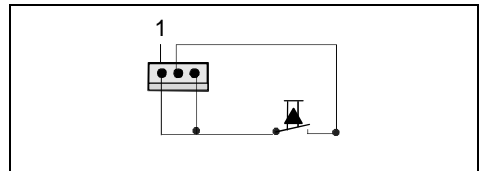

Pin	Signal
1	GND
2	Case open (low asserted)
3	Intrusion Switch Present (low asserted)

Configuration

Functions controlled by the switch block

Function	SW1 PWS	SW2 RCV	SW3 FWP	SW4 AUX
Password Skip	on	X	X	X
Off	off	X	X	X
Recovery BIOS	X	on	X	X
Off	X	off	X	X
Floppy write protect	X	X	on	X
Off	X	X	off	X
RTC - Reset and Clear CMOS*	X	X	X	on
Off	X	X	X	off

* RES is the onboard inscription for RTC



RES switch must not be in ON position during normal operation!

Supported ACPI system states

- S0 (working)
- S1 (sleeping)
- S3 (save to RAM)
- S4 (OS hibernate)
- S5 (soft off)

ACPI Switches: On/Off/Sleep/Wake by power button
On/Off/Sleep/Wake by keyboard-button

ACPI Wakeup Possibilities

Wakeup Source	Wakeup possible from system states
Power Button	S1 – S5
Keyboard Button	S1 – S5
RTC (Real-Time Clock = Timer)	S1 – S4
Serial Chipcard reader	S1 – S4
External Serial Port 1 (ring signal)	S1 – S4
PCI-card PME# signal	S1 – S4 (3,3V Aux power is provided to PCI cards by the system board)
Onboard LAN controller	S1 – S4
Internal USB Chipcard reader	S1 – S4
USB device	S1 – S4 (5V Aux power is provided to the USB device by the system board)
Keyboard / mouse	S1

USB power jumper function description

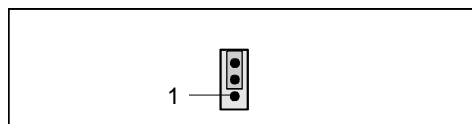

Pin	Signal
1	VCC
2	USB power connection
3	VCC_AUX

Jumper 2-3	Default setting: If the power supply supports auxiliary voltage the USB interface is permanently powered except when the main supply is plugged off. Wakeup from ACPI S1-S4 state possible.
Jumper 1-2	The USB interface is only powered in operating state. Wakeup from ACPI S1 state possible.

BIOS options

Please refer to BIOS description on the including CD-ROM (menu *Advanced System Management*).

Messages

Message LED:

The Message LED (frontpanel connector) shows two different states.

- A slow blinking (once a second) of the LED signals that any application has received a message. (ACPI- mode)
- A fast blinking (five times a second) of the LED signals a hardware problem.

The fast blinking LED can have several different causes:

- a necessary sensor is missing or defect
- an available sensor has overtemperature
- a fan is defect or not working properly
- a software is responsible for blinking



More detailed information are shown with an additional System Monitoring Software or on the monitor after reboot entering *BIOS Setup* (menu *Advanced System Management*).

BIOS: Please refer to BIOS description on the including CD-ROM.

Power

Power requirement

Source	Voltage	Maximum variation	Maximum current	Comment
Main power supply	+5.0 V	±5 %	15 A	
Main power supply	+12 V	±10 %	350 mA	
Main power supply	-12 V	±10 %	150 mA	
Main power supply	+3.3 V	±5 %	4 A	
Auxiliary power supply	+5.0 V	±5 %	1 A	without Wake On USB*
Auxiliary power supply	+5.0 V	±5 %	2 A	with Wake On USB*
Onboard power supply	1.8 - 3.5 V	±5 %	14 A	

* Refer to chapter "[USB power jumper function description](#)".

Power loadability

Fuse number	Maximum Fuse current	Function	Maximum function current
1	750 mA	Keyboard Port	Not specified
		Mouse Port	Not specified
		Game Port	Not specified
2	750 mA	Universal serial bus (USB) Port A	500 mA
3	750 mA	Universal serial bus (USB) Port B	500 mA

Documentation

- ▶ Insert the "Drivers & Utilities" CD.
- ▶ If the CD does not start automatically, run the *START.EXE* file in the main directory of the CD.
- ▶ Select your system board or your device.
- ▶ Select *Documentation*.
- ▶ Select - *Technical Manuals*
- ▶ Select - *Technical Manuals (BIOS)*



You may have to install the Acrobat Reader - Software on the CD-ROM (path: *utls/acrobat*) before reading!

For more details please read the according *readme.txt* files.

Installing drivers

- ▶ Insert the "Drivers & Utilities" CD.
- ▶ If the CD doesn't start automatically call the *START.EXE* file in the main directory of the CD.
- ▶ If the system board list is displayed select the system board or select under *Driver* the operating system used and the audio and video drivers.

Upgrades

Main memory

These slots are suitable for 64 to 512 Mbyte RDRAM memory modules of the RIMM format. The permissible total size of the main memory is 1 Gbyte.

Memory modules with different memory capacities can be combined.



All locations must always be occupied. Missing memory modules must be replaced with a C-RIMM module. This C-RIMM module must then be installed in the order of the locations **behind** the RIMM memory module:

Location bank 0 = RIMM memory module

Location bank 1 = C-RIMM memory module

The system board supports a maximum of 32 RDRAM modules at all locations for the main memory combined:

	Total size of RIMM module	Number of chips
64Mbit technology	64 Mbyte	8
	96 Mbyte	12
	128 Mbyte	16
128Mbit technology	64 Mbyte	4
	128 Mbyte	8
	192 Mbyte	12
	256 Mbyte	16
256Mbit technology	128 Mbyte	4
	256 Mbyte	8
	384 Mbyte	12
	512 Mbyte	16



You may only use 2.5V RIMM memory modules.

The system board supports memory modules of the speed classes PC600, PC700 and PC800. Always use memory modules of the same speed class. Otherwise the memory speed is limited to the slowest speed class. Optimal system speed is achieved when you use PC800 RDRAM memory modules.

Troubleshooting

Message BIOS update

The System BIOS provides optimum support for the processor you have chosen. If the message BIOS update for installed CPU failed

appears the microcode required for the processor inserted must still be loaded. Further information on this is available in the "BIOS Setup" manual on the "Drivers & Utilities" CD provided.

The screen stays blank

If your screen stays blank this may have the following cause:

The wrong RAM memory module has been inserted

► See the chapter "Main Memory" for information which memory modules can be used.

ACPI S3 (Save-to-RAM) and/or ACPI S4 (Save-to-Disk) doesn't work

This system board is fully compliant for ACPI S3 and S4. Therefore it is PC98 certified by Microsoft.

If you have any problems with ACPI please ensure that all of your components are supporting ACPI S3 and S4.

- Operating System
- Hardware and drivers of controllers (e. g. VGA, audio, LAN, SCSI controllers).



The system board D1127 supports Save-to-RAM. Therefore the D1127 is certified by Intel and Microsoft. This support must be also guaranteed by the operating system, the extension boards and the power supply. For the time neither Windows 98 1st edition nor Windows NT4.0 support this function reliably. Windows 98 SE and Windows 2000 will support ACPI S3. Unfortunately only a few extension boards work with functional Save-to-RAM compliant drivers (refer to <http://developer.intel.com/technology/iapc/involve.htm>).