

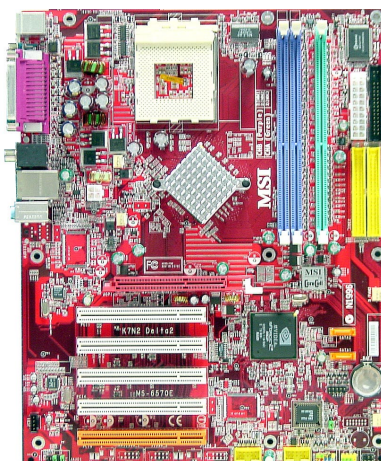

K7N2 Delta2 Series MS-6570E (v1.X) ATX Mainboard

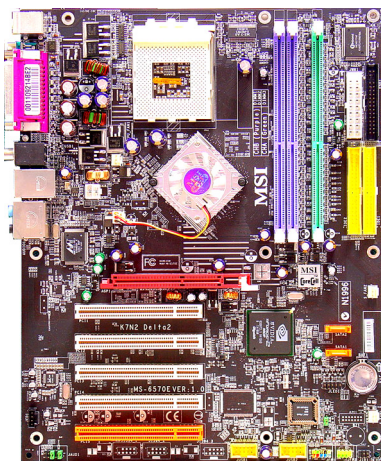

G52-M6570E9

Manual Rev: 1.1

Release Date: July 2004



FCC-B Radio Frequency Interference Statement

This equipment has been tested and found to comply with the limits for a class B digital device, pursuant to part 15 of the FCC rules. These limits are designed to provide reasonable protection against harmful interference when the equipment is operated in a commercial environment. This equipment generates, uses and can radiate radio frequency energy and, if not installed and used in accordance with the instruction manual, may cause harmful interference to radio communications. Operation of this equipment in a residential area is likely to cause harmful interference, in which case the user will be required to correct the interference at his own expense.

Notice 1

The changes or modifications not expressly approved by the party responsible for compliance could void the user's authority to operate the equipment.

Notice 2

Shielded interface cables and A.C. power cord, if any, must be used in order to comply with the emission limits.

VOIR LA NOTICE D'INSTALLATION AVANT DE RACCORDER AU RESEAU.

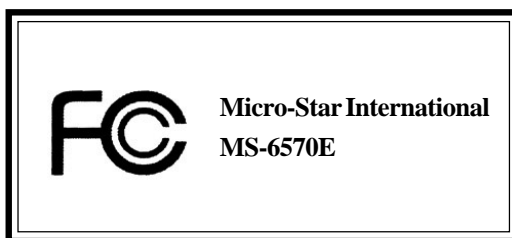

This device complies with Part 15 of the FCC Rules. Operation is subject to the following two conditions:

- (1) this device may not cause harmful interference, and
- (2) this device must accept any interference received, including interference that may cause undesired operation

Copyright Notice

The material in this document is the intellectual property of **MICRO-STAR INTERNATIONAL**. We take every care in the preparation of this document, but no guarantee is given as to the correctness of its contents. Our products are under continual improvement and we reserve the right to make changes without notice.

Trademarks

All trademarks are the properties of their respective owners.

AMD, Athlon™, Athlon™ XP, Thoroughbred™, and Duron™ are registered trademarks of AMD Corporation.

Intel® and Pentium® are registered trademarks of Intel Corporation.

PS/2 and OS®/2 are registered trademarks of International Business Machines Corporation.

Microsoft is a registered trademark of Microsoft Corporation. Windows® 98/2000/NT/XP are registered trademarks of Microsoft Corporation.

NVIDIA, the NVIDIA logo, DualNet, and nForce are registered trademarks or trademarks of NVIDIA Corporation in the United States and/or other countries.

Netware® is a registered trademark of Novell, Inc.

Award® is a registered trademark of Phoenix Technologies Ltd.

AMI® is a registered trademark of American Megatrends Inc.

Kensington and MicroSaver are registered trademarks of the Kensington Technology Group.

PCMCIA and CardBus are registered trademarks of the Personal Computer Memory Card International Association.

Revision History

Revision	Revision History	Date
V1.0	First release for PCB 1.X with nVidia nForce2 Ultra 400/IGP and nForce2 Gigabit MCP/RAID MCP	July 2004
V1.1	First release for PCB 1.X for standard version	July 2004

Technical Support

If a problem arises with your system and no solution can be obtained from the user's manual, please contact your place of purchase or local distributor. Alternatively, please try the following help resources for further guidance.

- Visit the MSI homepage & FAQ site for technical guide, BIOS updates, driver updates, and other information: <http://www.msi.com.tw> & http://www.msi.com.tw/program/service/faq/faq/esc_faq_list.php
- Contact our technical staff at: support@msi.com.tw

Safety Instructions

1. Always read the safety instructions carefully.
2. Keep this User's Manual for future reference.
3. Keep this equipment away from humidity.
4. Lay this equipment on a reliable flat surface before setting it up.
5. The openings on the enclosure are for air convection hence protects the equipment from overheating. **Do not cover the openings.**
6. Make sure the voltage of the power source and adjust properly 110/220V before connecting the equipment to the power inlet.
7. Place the power cord such a way that people can not step on it. Do not place anything over the power cord.
8. Always Unplug the Power Cord before inserting any add-on card or module.
9. All cautions and warnings on the equipment should be noted.
10. Never pour any liquid into the opening that could damage or cause electrical shock.
11. If any of the following situations arises, get the equipment checked by a service personnel:
 - The power cord or plug is damaged.
 - Liquid has penetrated into the equipment.
 - The equipment has been exposed to moisture.
 - The equipment has not work well or you can not get it work according to User's Manual.
 - The equipment has dropped and damaged.
 - The equipment has obvious sign of breakage.
12. **Do not leave this equipment in an environment unconditioned, storage temperature above 60°C (140°F), it may damage the equipment.**



CAUTION: Danger of explosion if battery is incorrectly replaced. Replace only with the same or equivalent type recommended by the manufacturer.

CONTENTS

FCC-B Radio Frequency Interference Statement	ii
Copyright Notice	iii
Revision History	iii
Technical Support	iv
Safety Instructions	iv
Chapter 1. Getting Started	1-1
Mainboard Specifications	1-2
Mainboard Layout	1-5
Packing Contents	1-7
Chapter 2. Hardware Setup	2-1
Quick Components Guide	2-2
Central Processing Unit: CPU	2-3
CPU Installation Procedures for Socket 462	2-4
Installing AMD Athlon CPU Cooler Set	2-5
Memory	2-6
Memory Speed/CPU FSB Support Matrix	2-6
DIMM Module Combination	2-6
Installing DDR Modules	2-7
Power Supply	2-8
ATX 20-Pin Power Connector: JWR1	2-8
ATX 12V Power Connector: JPW1	2-8
Back Panel	2-9
Mouse/Keyboard Connector	2-10
VGA Connector(optional)	2-10
Serial Port Connector	2-11
USB Connectors	2-11
LAN (RJ-45) Jack	2-12
SPDIF-out Port Connector	2-12
Audio Port Connectors	2-13
Parallel Port Connector: LPT1	2-14
Connectors	2-15
Floppy Disk Drive Connector: FDD1	2-15
Fan Power Connectors: CPU_FAN1/S_FAN1/S_FAN2/NB_FAN1	2-15
Hard Disk Connectors: IDE1 & IDE2	2-16
Serial ATA RAID Connectors controlled by nForce2 RAID MCP:	
SATA1~SATA2	2-17
Front Panel Connectors: JFP1 & JFP2	2-18

CD-In Connector: JCD1	2-19
Front Panel Audio Connector: JAUD1	2-19
Chassis Intrusion Switch Connector: JCI1	2-20
Front USB Connectors: JUSB1 & JUSB2	2-20
IEEE 1394 Connectors: J1394_1, J1394_2, J1394_3 (optional)	2-21
D-Bracket™ 2 Connector: JLED1	2-22
IrDA Infrared Module Header: JIR1	2-22
Jumpers	2-23
Clear CMOS Jumper: JBAT1	2-23
Slots	2-24
AGP (Accelerated Graphics Port) Slot	2-24
PCI (Peripheral Component Interconnect) Slots	2-24
PCI Interrupt Request Routing	2-24
Chapter 3. BIOS Setup	3-1
Entering Setup	3-2
Control Keys	3-2
Getting Help	3-2
The Main Menu	3-3
Standard CMOS Features	3-5
Advanced BIOS Features	3-7
Advanced Chipset Features	3-10
Integrated Peripherals	3-11
Power Management Setup	3-17
PNP/PCI Configurations	3-20
H/W Monitor	3-22
Cell Menu	3-24
Load Fail-Safe/Optimized Defaults	3-28
Set Supervisor/User Password	3-29
Chapter 4. Introduction to DigiCell	4-1
Main	4-2
H/W Diagnostic	4-4
Communication	4-5
Software Access Point	4-6
Terminology	4-6
Access Point Mode	4-7
WLAN Card Mode	4-8
Live Update	4-9
MEGASTICK	4-10

Basic Function	4-10
Non-Unicode programs supported	4-12
Core Center (for AMD K7 Processor)	4-14
Audio Speaker Setting	4-16
Power on Agent	4-18
Power On	4-18
Power Off / Restart	4-19
Start With	4-19
Auto Login	4-20
Chapter 5. nVIDIA RAID Introduction	5-1
Introduction	5-2
System Requirement	5-2
RAID Arrays	5-2
Summary of RAID Configurations	5-2
RAID Configuration	5-3
Basic Configuration Instructions	5-3
Setting Up the NVRAID BIOS	5-3
NVIDIA RAID Utility Installation	5-7
Installing the NVIDIA RAID Software Under Windows (for Non-bootable RAID Array)	5-7
Installing the RAID Driver (for bootable RAID Array)	5-8
Initializing and Using the Disk Array	5-10
RAID Drives Management	5-12
Viewing RAID Array Configurations	5-12
Setting Up a Spare RAID Disk	5-14
Rebuilding a RAID Mirrored Array	5-20



Getting Started

Thank you for purchasing the K7N2 Delta2 Series (MS-6570E v1.X) ATX mainboard. The K7N2 Delta2 Series mainboard is based on NVIDIA® nForce™2 Ultra 400/IGP & NVIDIA® Gigabit MCP/RAID MCP for optimal system efficiency. Designed to fit the advanced AMD® Athlon™, Athlon™ XP or Duron™ processors, the K7N2 Delta2 Series mainboard delivers a high performance and professional desktop platform solution.

Mainboard Specifications

CPU

- Supports Socket A (Socket-462) for AMD Athlon/Athlon XP /Duron processors
- Supports from 1100MHz to FSB 400 Athlon XP 3200+ processor
(For the latest information about CPU, please visit http://www.msi.com.tw/program/products/mainboard/mbd/pro_mbd_cpu_support.php)

Chipset

- NVIDIA® nForce2 Ultra 400/nForce2 IGP
 - FSB @266/333/400 MHz
 - AGP 8X and PCI Advanced high performance memory controller
 - Supports AGP 3.0 8x interface
 - Integrated graphics controller (IGP only)
- NVIDIA nForce2 Gigabit MCP/RAID MCP
 - Integrated Ethernet MAC
 - Integrated Hardware Sound Blaster/Direct Sound AC97 audio
 - Ultra DMA 66/100/133 master mode PCI EIDE controller
 - Supports USB 2.0
 - Integrated SATA Interface

Main Memory

- Supports six memory banks dual channel DDR, using three 184-pin DDR DIMMs
- Supports a maximum memory size up to 3GB
- Supports 2.5v DDR SDRAM DIMM
(For the updated supporting memory modules, please visit http://www.msi.com.tw/program/products/mainboard/mbd/pro_mbd_trp_list.php.)

Slots

- One AGP (Accelerated Graphics Port) slot
 - Supports AGP 3.0 8X
- Five 32-bit Master PCI bus slots
- Supports 3.3V/5V PCI bus Interface

USB Interface

- 8 USB ports
 - Controlled by Gigabit MCP/RAID MCP southbridge
 - 4 ports in the rear I/O, 4 ports via external bracket

On-Board IDE

- Two IDE controllers integrated on the nVIDIA nForce2 Gigabit MCP/RAID MCP chipset providing IDE HDD/CD-ROM with PIO, Bus Master and Ultra DMA66/100/133 operation modes
- Can connect up to four IDE devices

On-Board Peripherals

- On-Board Peripherals include:
 - 1 floppy port supports 1 FDD with 360K, 720K, 1.2M, 1.44M and 2.88Mbytes
 - 1 serial port
 - 1 VGA port (IGP only)
 - 1 parallel port supports SPP/EPP/ECP mode
 - audio ports in vertical
 - 1 D-Bracket2 pinheader
- On-Board 10/100/1000 (Optional) Ethernet
 - A 802.3 NVIDIA MAC for 1000 BASE-T/100 BASE-T/10 BASE-T Gigabit/Fast Ethernet/Ethernet
 - RGMII for Gigabit/Fast Ethernet/Ethernet (Gigabit MCP south bridge)
 - MII for Fast Ethernet/Ethernet (RAID MCP south bridge)

IEEE1394 (Optional)

- Supports up to 3 * 1394 ports (via external bracket). Transfer rate is up to 400Mbps.

Audio

- Chip integrated (5.1 channel H/W audio)
 - Direct Sound AC97 audio
 - 6 channel analog output
 - Digital SPDIF out signal compatible W/S-Bracket

SATA Interface

- Integrated SATA Phy, supporting up to 2 ports
- One SATA controller, supporting two drives in master mode

ATTENTION!!!

Please note that users cannot install OS, neither WinME nor Win98, in their SATA hard drive. Under these two OSs, SATA can only be used as a normal storage device.

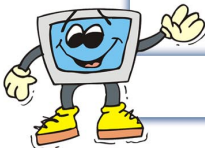

NV RAID (Software)

- Supports 2 serial ATA plus 1 ATA 133
 - RAID 0, or 1, 0+1, JBOD is supported
 - Booting from RAID
 - Cross controller RAID support
 - Rebuilding on the Fly
 - Spare Disk Allocation
- Supports Windows 2000 and later versions

BIOS

- The mainboard BIOS provides "Plug & Play" BIOS which detects the peripheral devices and expansion cards of the board automatically.
- The mainboard provides a Desktop Management Interface (DMI) function which records your mainboard specifications.

Dimension

- ATX Form Factor: 30.4 cm (L) x 24 cm (W)

Mounting

- 6 mounting holes

Others

- Suspend to RAM/Disk (S3/S4)
- Supports PCI 2.3

ATTENTION!!!

To create a bootable RAID volume for a Windows 2000 environment, Microsoft's Windows 2000 Service Pack 4 (SP4) is required. As the end user cannot boot without SP4, a combination installation CD must be created before attempting to install the operating system onto the bootable RAID volume.

To create the combination installation CD, please refer to the following website:

<http://www.microsoft.com/windows2000/downloads/servicepacks/sp4/HFdeploy.htm>

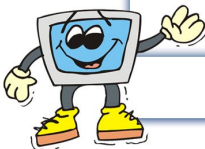

Mainboard Layout

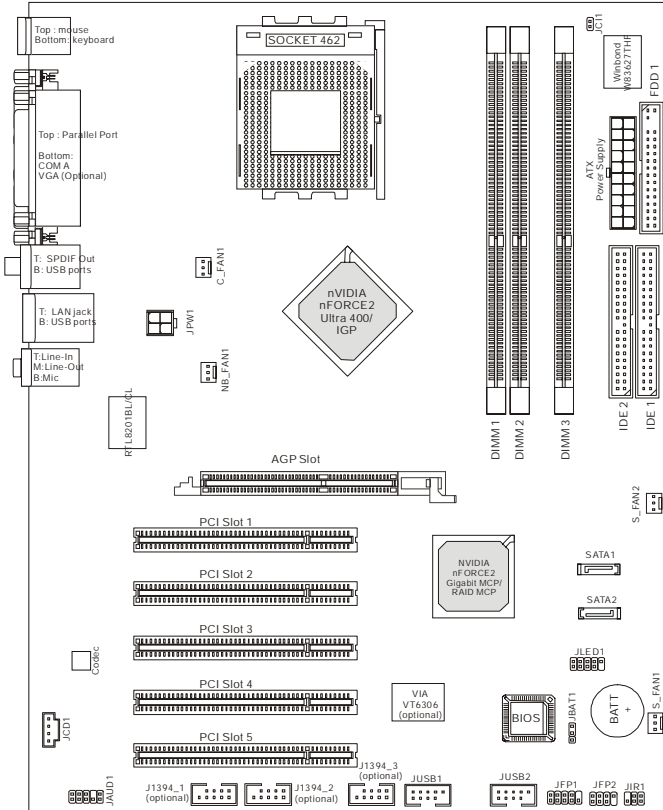

Type I

K7N2 Delta2 (MS-6570E v1.X) Series Mainboard

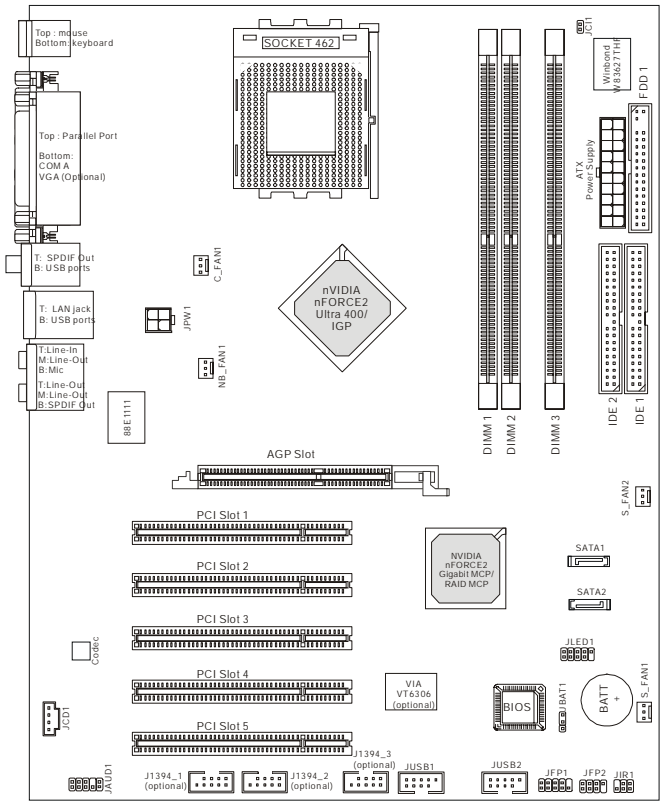

Type II

K7N2 Delta2 (MS-6570E v1.X) Series Mainboard

Packing Contents

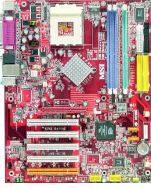

MSI motherboard



MSI Driver/Utility CD



SATA Cable (Optional)



Power Cable



D-Bracket 2 (Optional)



Round Cable of
IDE Devices



User's Guide



Back IO Shield



Round Cable of
Floppy Disk

2

Hardware Setup

This chapter tells you how to install the CPU, memory modules, and expansion cards, as well as how to setup the jumpers on the mainboard. Also, it provides the instructions on connecting the peripheral devices, such as the mouse, keyboard, etc.

While doing the installation, be careful in holding the components and follow the installation procedures.

Quick Components Guide

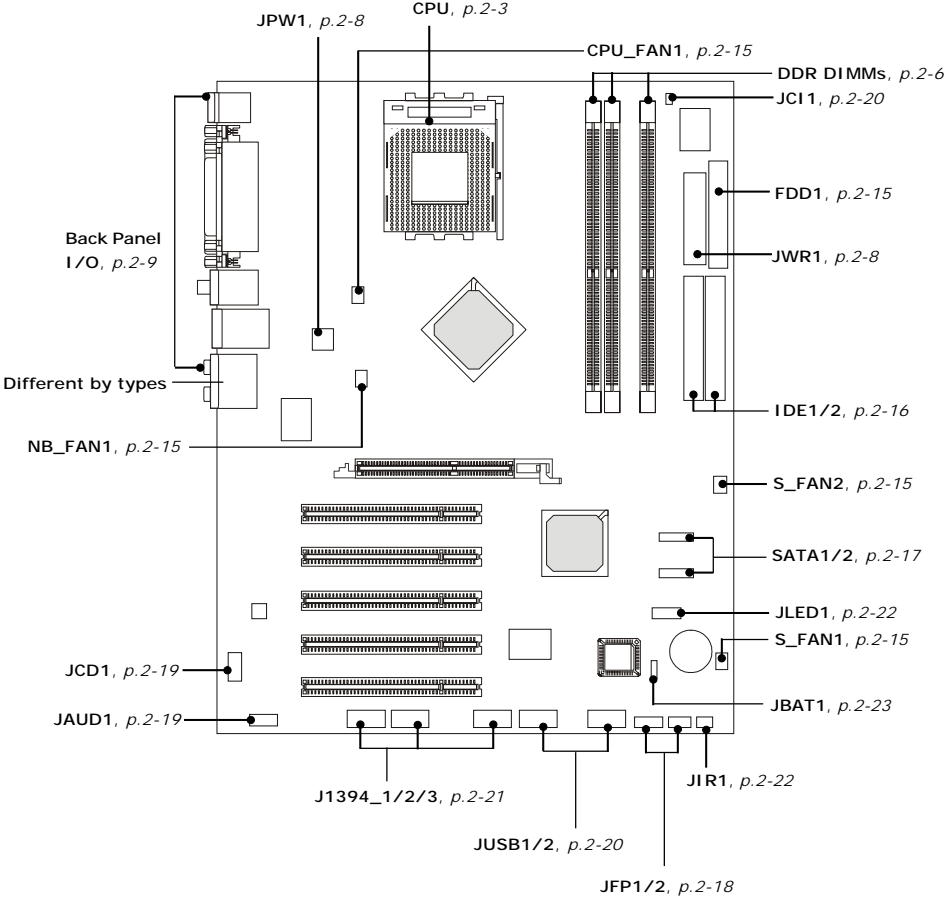

Central Processing Unit: CPU

The mainboard supports AMD® Athlon™, Athlon™ XP and Duron™ processors in the 462 pin package. The mainboard uses a CPU socket called Socket A for easy CPU installation. When you are installing the CPU, **make sure the CPU has a heat sink and a cooling fan attached on the top to prevent overheating.** If you do not find the heat sink and cooling fan, contact your dealer to purchase and install them before turning on the computer.

For the latest information about CPU, please visit http://www.msi.com.tw/program/products/mainboard/mbd/pro_mbd_cpu_support.php.



MSI Reminds You...

Overheating

Overheating will seriously damage the CPU and system, always make sure the cooling fan can work properly to protect the CPU from overheating.

Replacing the CPU

While replacing the CPU, always turn off the ATX power supply or unplug the power supply's power cord from grounded outlet first to ensure the safety of CPU.

Overclocking

*This motherboard is designed to support overclocking. However, please make sure your components are able to tolerate such abnormal setting, while doing overclocking. Any attempt to operate beyond product specifications is not recommended. **We do not guarantee the damages or risks caused by inadequate operation or beyond product specifications.***

CPU Core Speed Derivation Procedure

CPU Clock multiplied by Core/Bus ratio equals the CPU core speed.

For example:

If	CPU Clock	=	100MHz
	Core/Bus ratio =	14	
then	CPU core speed	=	Host Clock x Core/Bus ratio
		=	100MHz x 14
		=	1.4 GHz

CPU Installation Procedures for Socket 462

1. Please turn off the power and unplug the power cord before installing the CPU.
2. Pull the lever sideways away from the socket. Make sure to raise the lever up to a 90-degree angle.
3. Look for the gold arrow. The gold arrow should point towards the lever pivot. The CPU can only fit in the correct orientation.
4. If the CPU is correctly installed, the pins should be completely embedded into the socket and can not be seen. Please note that any violation of the correct installation procedures may cause permanent damages to your mainboard.
5. Press the CPU down firmly into the socket and close the lever. As the CPU is likely to move while the lever is being closed, always close the lever with your fingers pressing tightly on top of the CPU to make sure the CPU is properly and completely embedded into the socket.

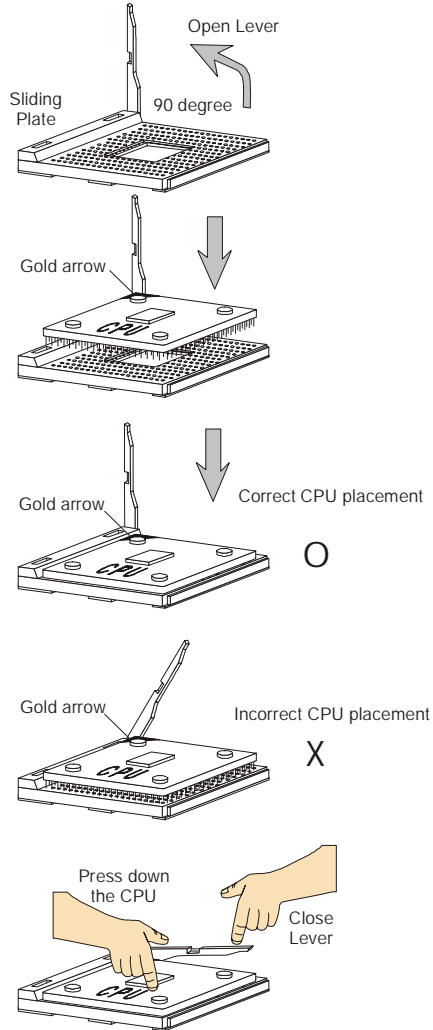

Installing AMD Athlon CPU (Socket 462) Cooler Set

The following instructions will guide you through the heat sink installation procedures. Please consult your agent for the proper CPU cooler set.

1. Position your CPU cooler set onto the CPU.
2. Use one end of the clip to hook the latch of the CPU sliding plate.
3. Hook the other latch to fix the cooling fan set. You may need a screw drive to press down the other side of the clip.
4. Connect the fan to the power supply connector provided on your mainboard.

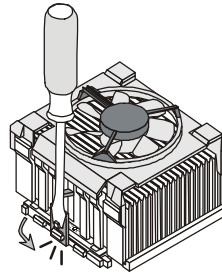
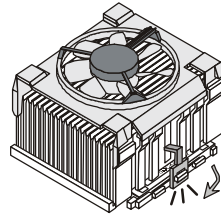
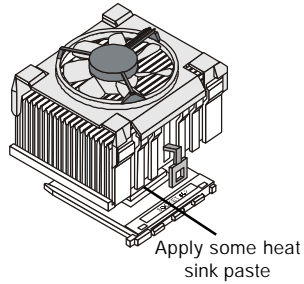

MSI Reminds You...

Please apply some heat sink paste on top of CPU to dissipate the heat more effectively.

Memory

The mainboard provides 3 slots for 184-pin DDR SDRAM DIMM (Double In-Line Memory Module) modules and supports the memory size up to 3GB. You can install DDR266 / 333/400 modules on the DDR DIMM slots (DDR 1~3).

Please note that the system will support dual channel DDR when you install DDR modules on DIMM1 (purple slot) and DIMM3 (green slot), or DIMM2 (purple slot) and DIMM3 (green slot).

For the updated supporting memory modules, please visit http://www.msi.com.tw/program/products/mainboard/mbd/pro_mbd_trp_list.php.

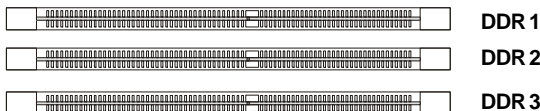

Memory Speed/CPU FSB Support Matrix

Memory \ CPU FSB	DDR 266	DDR 333	DDR 400
133MHz	Yes	Yes	Yes
166MHz	Yes	Yes	Yes
200MHz	Yes	Yes	Yes

DIMM Module Combination

Install at least one DIMM module on the slots. You can install either single- or double-sided modules in any order to meet your own needs.

Memory modules can be installed in any combination as follows:

Slot	Memory Module	Total Memory
DIMM 1 (Bank 0 & 1)	S/D	64MB~1GB
DIMM 2 (Bank 2 & 3)	S/D	64MB~1GB
DIMM 3 (Bank 4 & 5)	S/D	64MB~1GB
Maximum System Memory Supported		64MB~3GB

S: Single Side

D: Double Side

Installing DDR Modules

1. The DDR DIMM has only one notch on the center of module. The module will only fit in the right orientation.
2. Insert the DIMM memory module vertically into the DIMM slot. Then push it in until the golden finger on the memory module is deeply inserted in the socket.
3. The plastic clip at each side of the DIMM slot will automatically close.

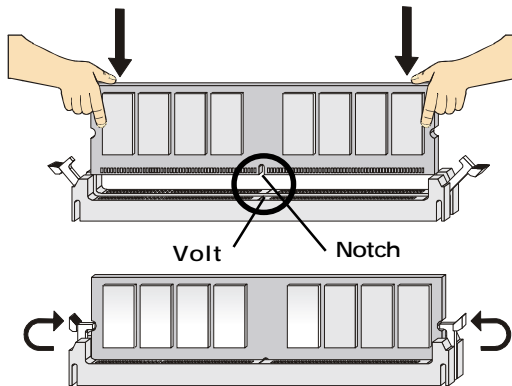

MSI Reminds You...

You can barely see the golden finger if the module is properly inserted in the socket.

Power Supply

The mainboard supports ATX power supply for the power system. Before inserting the power supply connector, always make sure that all components are installed properly to ensure that no damage will be caused.

ATX 20-Pin Power Connector: JWR1

This connector allows you to connect to an ATX power supply. To connect to the ATX power supply, make sure the plug of the power supply is inserted in the proper orientation and the pins are aligned. Then push down the power supply firmly into the connector.

ATX 12V Power Connector: JPW1

This 12V power connector is used to provide power to the CPU.

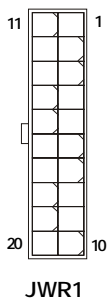

JWR1 Pin Definition

PIN	SIGNAL	PIN	SIGNAL
1	3.3V	11	3.3V
2	3.3V	12	-12V
3	GND	13	GND
4	5V	14	PS_ON
5	GND	15	GND
6	5V	16	GND
7	GND	17	GND
8	PW_OK	18	-5V
9	5V_SB	19	5V
10	12V	20	5V

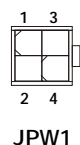

JPW1 Pin Definition

PIN	SIGNAL
1	GND
2	GND
3	12V
4	12V



MSI Reminds You...

1. These two connectors connect to the ATX power supply and have to work together to ensure stable operation of the mainboard.
2. Power supply of 350 watts (and above) is highly recommended for system stability.

Back Panel

The back panel provides the following connectors:

K7N2 Delta2 Series Type I

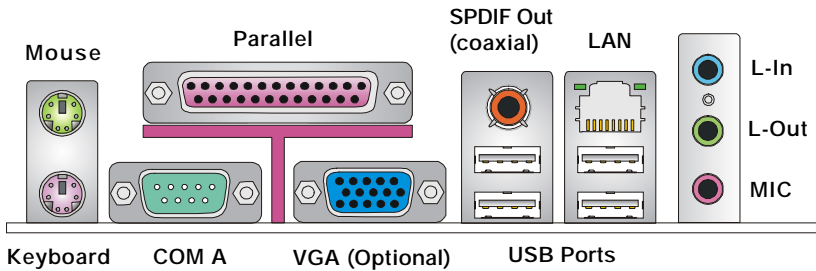

K7N2 Delta2 Series Type II

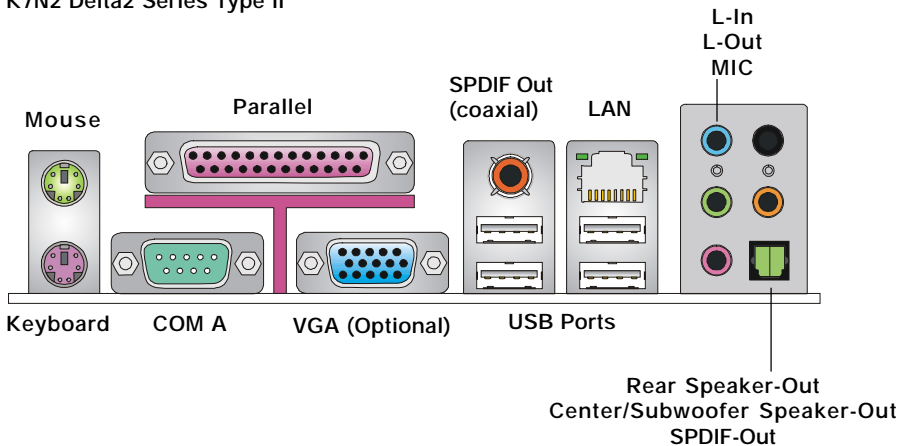

Mouse/Keyboard Connector

The mainboard provides a standard PS/2[®] mouse/keyboard mini DIN connector for attaching a PS/2[®] mouse/keyboard. You can plug a PS/2[®] mouse/keyboard directly into this connector. The connector location and pin assignments are as follows:



**PS/2 Mouse / Keyboard
(6-pin Female)**

Pin Definition

PIN	SIGNAL	DESCRIPTION
1	Mouse/Keyboard Data	Mouse/Keyboard data
2	NC	No connection
3	GND	Ground
4	VCC	+5V
5	Mouse/Keyboard Clock	Mouse/Keyboard clock
6	NC	No connection

VGA Connector (Optional)

The mainboard provides a DB 15-pin female connector to connect a VGA monitor.

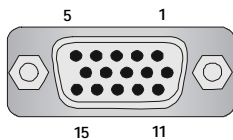

**VGA Connector
(DB 15-pin)**

Pin	Signal Description
1	RED
2	GREEN
3	BLUE
4	N/C
5	GND
6	GND
7	GND
8	GND
9	+5V
10	GND
11	N/C
12	SDA
13	Horizontal Sync
14	Vertical Sync
15	SCL

Serial Port Connector

The mainboard offers one 9-pin male DIN connector as the serial port. The port is a 16550A high speed communication port that sends/receives 16 bytes FIFOs. You can attach a serial mouse or other serial devices directly to the connector.

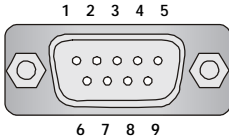

9-Pin Male DIN Connector

Pin Definition

PIN	SIGNAL	DESCRIPTION
1	DCD	Data Carry Detect
2	SIN	Serial In or Receive Data
3	SOUT	Serial Out or Transmit Data
4	DTR	Data Terminal Ready)
5	GND	Ground
6	DSR	Data Set Ready
7	RTS	Request To Send
8	CTS	Clear To Send
9	RI	Ring Indicate

USB Connectors

The mainboard provides an OHCI (Open Host Controller Interface) Universal Serial Bus root for attaching USB devices such as keyboard, mouse or other USB-compatible devices. You can plug the USB device directly into the connector.

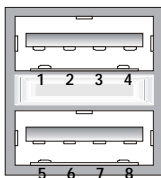

USB Ports

USB Port Description

PIN	SIGNAL	DESCRIPTION
1	VCC	+5V
2	-Data 0	Negative Data Channel 0
3	+Data0	Positive Data Channel 0
4	GND	Ground
5	VCC	+5V
6	-Data 1	Negative Data Channel 1
7	+Data 1	Positive Data Channel 1
8	GND	Ground

LAN (RJ-45) Jack

The mainboard provides 1 standard RJ-45 jack for connection to single Local Area Network (LAN). This Giga-bit LAN enables data to be transferred at 1000, 100 or 10Mbps. You can connect a network cable to either LAN jack.

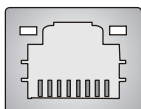

RJ-45 LAN Jack

Giga-bit LAN Pin Definition

PIN	SIGNAL	DESCRIPTION
1	D0P	Differential Pair 0+
2	D0N	Differential Pair 0-
3	D1P	Differential Pair 1+
4	D2P	Differential Pair 2+
5	D2N	Differential Pair 2-
6	D1N	Differential Pair 1-
7	D3P	Differential Pair 3+
8	D3N	Differential Pair 3-

SPDIF-out Port Connector

SPDIF-out is a jack for coaxial fiber connection for digital audio transmission.



SPDIF-out port

Audio Port Connectors (Optional)

This mainboard may provide two different combinations of Audio Port Connectors: TYPE I and TYPE II. Find the correct type according to the mainboard you have with you.

Both TYPE I and TYPE II integrate three audio jacks for 2-channel mode stereo speaker output: **Line In** is used for external CD player, Tape player, or other audio devices. **Line Out** is a connector for Speakers or Headphones. **MIC** is a connector for microphones.

However, TYPE II also integrates an advanced audio application which is provided by Realtek ALC655 to offer support for **6-channel audio operation** and can turn rear audio connectors from 2-channel to 4-/6-channel audio. For more information on **6-channel audio operation**, please refer to *Chapter 4: Introduction to DigiCell*.

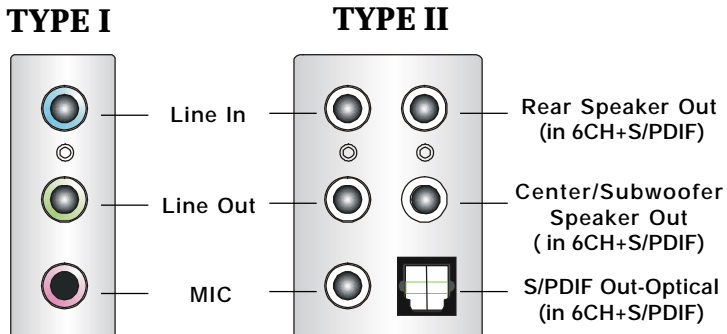

MSI Reminds You...

For advanced audio application, Realtek ALC655 audio chip is provided to offer support for **6-channel audio operation** and can turn rear audio connectors from 2-channel to 4-/6-channel audio.

Parallel Port Connector: LPT1

The mainboard provides a 25-pin female centronic connector as LPT. A parallel port is a standard printer port that supports Enhanced Parallel Port (EPP) and Extended Capabilities Parallel Port (ECP) mode.

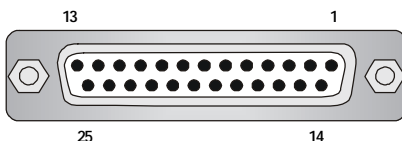

Pin Definition

PIN	SIGNAL	DESCRIPTION
1	STROBE	Strobe
2	DATA0	Data0
3	DATA1	Data1
4	DATA2	Data2
5	DATA3	Data3
6	DATA4	Data4
7	DATA5	Data5
8	DATA6	Data6
9	DATA7	Data7
10	ACK#	Acknowledge
11	BUSY	Busy
12	PE	PaperEnd
13	SELECT	Select
14	AUTO FEED#	Automatic Feed
15	ERR#	Error
16	INIT#	Initialize Printer
17	SLIN#	Select In
18	GND	Ground
19	GND	Ground
20	GND	Ground
21	GND	Ground
22	GND	Ground
23	GND	Ground
24	GND	Ground
25	GND	Ground

Connectors

The mainboard provides connectors to connect to FDD, IDE HDD, case, LAN, USB Ports, IR module and CPU/System FAN.

Floppy Disk Drive Connector: FDD1

The mainboard provides a standard floppy disk drive connector that supports 360K, 720K, 1.2M, 1.44M and 2.88M floppy disk types.



Fan Power Connectors: CPU_FAN1/S_FAN1/S_FAN2/NB_FAN1

The CPU_FAN1 (processor fan), S_FAN1 (system fan 1), S_FAN2 (system fan 2) and NB_FAN1 (NorthBridge Chipset fan) support system cooling fan with +12V. It supports three-pin head connector. When connecting the wire to the connectors, always take note that the red wire is the positive and should be connected to the +12V, the black wire is Ground and should be connected to GND. If the mainboard has a System Hardware Monitor chipset on-board, you must use a specially designed fan with speed sensor to take advantage of the CPU fan control.

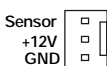

CPU_FAN1

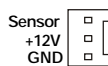

S_FAN1

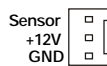

S_FAN2

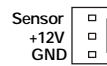

NB_FAN1



MSI Reminds You...

1. Always consult the vendors for proper CPU cooling fan.
2. Please refer to the recommended CPU fans at AMD® official website.

Hard Disk Connectors: IDE1 & IDE2

The mainboard has a 32-bit Enhanced PCI IDE and Ultra DMA 33/66/100/133 controller that provides PIO mode 0-4, Bus Master, and Ultra DMA 33/66/100/133 function. You can connect up to four hard disk drives, CD-ROM, 120MB Floppy (reserved for future BIOS) and other devices.

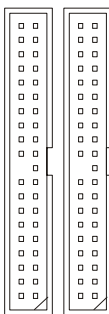

IDE2 IDE1

IDE1 (Primary IDE Connector)

The first hard drive should always be connected to IDE1. IDE1 can connect a Master and a Slave drive. You must configure second hard drive to Slave mode by setting the jumper accordingly.

IDE2 (Secondary IDE Connector)

IDE2 can also connect a Master and a Slave drive.



MSI Reminds You...

If you install two hard disks on cable, you must configure the second drive to Slave mode by setting its jumper. Refer to the hard disk documentation supplied by hard disk vendors for jumper setting instructions.

Serial ATA RAID Connectors controlled by nForce2 RAID MCP: SATA1/SATA2

The Southbridge of this mainboard is nForce2 RAID MCP which supports two serial ATA connectors SATA1 and SATA2.

SATA1 and SATA2 are dual high-speed Serial ATA interface ports. Each supports 1st generation serial ATA data rates of 150 MB/s. Both connectors are fully compliant with Serial ATA 1.0 specifications. Each Serial ATA connector can connect to 1 hard disk device.

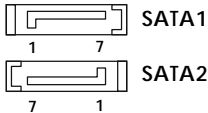

SATA1/SATA2 Pin Definition

PIN	SIGNAL	PIN	SIGNAL
1	GND	2	TXP
3	TXN	4	GND
5	RXN	6	RXP
7	GND		

Serial ATA cable



Connect to serial ATA ports

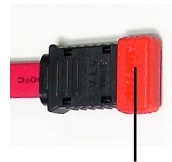

Take out the dust cover and connect to the hard disk devices



MSI Reminds You...

Please do not fold the serial ATA cable in a 90-degree angle, which will cause the loss of data during the transmission.

Front Panel Connectors: JFP1 & JFP2

The mainboard provides two front panel connectors for electrical connection to the front panel switches and LEDs. JFP1 is compliant with Intel® Front Panel I/O Connectivity Design Guide.

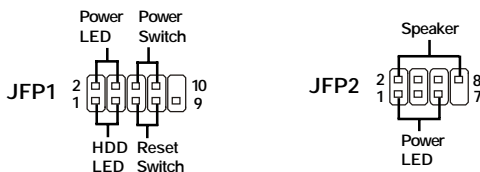

JFP1 Pin Definition

PIN	SIGNAL	DESCRIPTION
1	HD_LED_P	Hard disk LED pull-up
2	FP PWR/SLP	MSG LED pull-up
3	HD_LED_N	Hard disk active LED
4	FP PWR/SLP	MSG LED pull-up
5	RST_SW_N	Reset Switch low reference pull-down to GND
6	PWR_SW_P	Power Switch high reference pull-up
7	RST_SW_P	Reset Switch high reference pull-up
8	PWR_SW_N	Power Switch low reference pull-down to GND
9	RSVD_DNU	Reserved. Do not use.

JFP2 Pin Definition

PIN	SIGNAL	PIN	SIGNAL
1	GND	2	SPK-
3	SLED	4	BUZ+
5	PLED	6	BUZ-
7	NC	8	SPK+

CD-In Connector: JCD1

The connector is for CD-ROM audio connector.

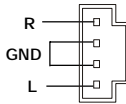

JCD1

Front Panel Audio Connector: JAUD1

The JAUD1 front panel audio connector allows you to connect to the front panel audio and is compliant with Intel® Front Panel I/O Connectivity Design Guide.



Pin Definition

PIN	SIGNAL	DESCRIPTION
1	AUD_MIC	Front panel microphone input signal
2	AUD_GND	Ground used by analog audio circuits
3	AUD_MIC_BIAS	Microphone power
4	AUD_VCC	Filtered +5V used by analog audio circuits
5	AUD_FPOUT_R	Right channel audio signal to front panel
6	AUD_RET_R	Right channel audio signal return from front panel
7	HP_ON	Reserved for future use to control headphone amplifier
8	KEY	No pin
9	AUD_FPOUT_L	Left channel audio signal to front panel
10	AUD_RET_L	Left channel audio signal return from front panel



MSI Reminds You...

If you don't want to connect to the front audio header, pins 5 & 6, 9 & 10 have to be jumpered in order to have signal output directed to the rear audio ports. Otherwise, the Line-Out connector on the back panel will not function.

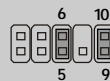

Chassis Intrusion Switch Connector: JCI1

This connector is connected to a 2-pin chassis switch. If the chassis is opened, the switch will be short connected. The system will record this status and show a warning message on the screen. To clear the warning, you must enter the BIOS utility and clear the record. JCI1 is compliant with Intel® Front Panel I/O Connectivity Design Guide.



JCI1

Front USB Connectors: JUSB1 & JUSB2

The mainboard provides two standard USB 2.0 pin headers *JUSB1* & *JUSB2*. USB 2.0 technology increases data transfer rate up to a maximum throughput of 480Mbps, which is 40 times faster than USB 1.1, and is ideal for connecting high-speed USB interface peripherals such as **USB HDD, digital cameras, MP3 players, printers, modems and the like.**

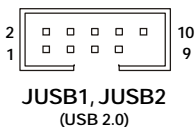

JUSB1 & JUSB2 Pin Definition

PIN	SIGNAL	PIN	SIGNAL
1	VCC	2	VCC
3	USB0-	4	USB1-
5	USB0+	6	USB1+
7	GND	8	GND
9	Key (no pin)	10	USBOC

Connected to JUSB1 or JUSB2

USB 2.0 Bracket (Optional)



IEEE 1394 Connectors: J1394_1, J1394_2, J1394_3 (Optional)

The mainboard provides three 1394 pin headers that allow you to connect IEEE 1394 ports via an external IEEE1394 bracket (optional).

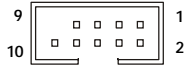

J1394_1/J1394_2/J1394_3

Pin Definition

PIN	SIGNAL	PIN	SIGNAL
1	TPA+	2	TPA-
3	Ground	4	Ground
5	TPB+	6	TPB-
7	Cable power	8	Cable power
9	Key (no pin)	10	Ground

IEEE1394 Bracket (Optional)



Foolproof Design

D-Bracket™ 2 Connector: JLED1

The mainboard comes with a JLED1 connector for you to connect to D-Bracket™ 2. D-Bracket™ 2 is a USB Bracket that supports both USB1.1 & 2.0 spec. It integrates four LEDs and allows users to identify system problem through 16 various combinations of LED signals.

IrDA Infrared Module Header: JIR1

The connector allows you to connect to IrDA Infrared module. You must configure the setting through the BIOS setup to use the IR function. JIR1 is compliant with Intel® Front Panel I/O Connectivity Design Guide.

JLED1 Pin Definition

Pin	Signal
1	DBG1 (high for green color)
2	DBR1 (high for red color)
3	DBG2 (high for green color)
4	DBR2 (high for red color)
5	DBG3 (high for green color)
6	DBR3 (high for red color)
7	DBG4 (high for green color)
8	DBR4 (high for red color)
9	Key
10	NC

JLED1



JIR1

JIR1 Pin Definition

Pin	Signal
1	NC
2	NC
3	VCC5
4	GND
5	IRTX
6	IRRX

Connected to JLED1
 Connected to JUSB1
 or JUSB2

D-Bracket™ 2 (Optional)



Jumpers

The motherboard provides the following jumpers for you to set the computer's function. This section will explain how to change your motherboard's function through the use of jumpers.

Clear CMOS Jumper: JBAT1

There is a CMOS RAM on board that has a power supply from external battery to keep the system configuration data. With the CMOS RAM, the system can automatically boot OS every time it is turned on. If you want to clear the system configuration, use the JBAT1 (Clear CMOS Jumper) to clear data. Follow the instructions below to clear the data:

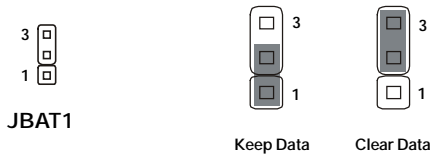

MSI Reminds You...

You can clear CMOS by shorting 2-3 pin while the system is off. Then return to 1-2 pin position. Avoid clearing the CMOS while the system is on; it will damage the mainboard.

Slots

The mainboard provides one AGP slot and five 32-bit PCI bus slots.

AGP (Accelerated Graphics Port) Slot

The AGP slot allows you to insert the AGP graphics card. AGP is an interface specification designed for the throughput demands of 3D graphics. It introduces a 66MHz, 32-bit channel for the graphics controller to directly access main memory. The slot supports 8x/4x AGP card.



AGP Slot

PCI (Peripheral Component Interconnect) Slots

The PCI slots allow you to insert the expansion cards to meet your needs. When adding or removing expansion cards, make sure that you unplug the power supply first. Meanwhile, read the documentation for the expansion card to make any necessary hardware or software settings for the expansion card, such as jumpers, switches or BIOS configuration.

The orange PCI slot (PCI5) also works as a communication slot, which allows you to insert the communication card.

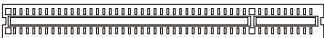

PCI Slots

PCI Interrupt Request Routing

The IRQ, acronym of interrupt request line and pronounced I-R-Q, are hardware lines over which devices can send interrupt signals to the microprocessor. The PCI IRQ pins are typically connected to the PCI bus INT A# ~ INT D# pins as follows:

	Order 1	Order 2	Order 3	Order 4
PCI Slot 1	PIRQC#	PIRQD#	PIRQA#	PIRQB#
PCI Slot 2	PIRQD#	PIRQA#	PIRQB#	PIRQC#
PCI Slot 3	PIRQA#	PIRQB#	PIRQC#	PIRQD#
PCI Slot 4	PIRQB#	PIRQC#	PIRQD#	PIRQA#
PCI Slot 5	PIRQC#	PIRQD#	PIRQA#	PIRQB#
AGP	PIRQB#			

3

BIOS Setup

This chapter provides information on the BIOS Setup program and allows you to configure the system for optimum use.

You may need to run the Setup program when:

- ◆ An error message appears on the screen during system boot up, and requests you to run SETUP.
- ◆ You want to change the default settings for customized features.



MSI Reminds You...

1. *The items under each BIOS category described in this chapter are under continuous update for better system performance. Therefore, the description may be slightly different from the latest BIOS and should be held for reference only.*
2. *While booting up, the BIOS version is shown in the 1st line appearing after the memory count. It is usually in the format:
example: W7005MS V2.0 091096*

where:

1st digit refers to BIOS maker as A=AMI(R); W=AWARD(R)

2nd - 5th digit refers to the model number.

6th - 7th digit refers to the customer, MS=all standard customers.

V2.0 refers to the BIOS version.

091096 refers to the date this BIOS is released.

Entering Setup

Power on the computer and the system will start POST (Power On Self Test) process. When the message below appears on the screen, press key to enter Setup.

Press DEL to enter SETUP

If the message disappears before you respond and you still wish to enter Setup, restart the system by turning it OFF and On or pressing the RESET button. You may also restart the system by simultaneously pressing <Ctrl>, <Alt>, and <Delete> keys.

Control Keys

<↑>	Move to the previous item
<↓>	Move to the next item
<←>	Move to the item in the left hand
<→>	Move to the item in the right hand
<Enter>	Select the item
<Esc>	Jumps to the Exit menu or returns to the main menu from a submenu
<+ /PU>	Increase the numeric value or make changes
<- /PD>	Decrease the numeric value or make changes
<F1>	General help, only for Status Page Setup Menu and Option Page Setup Menu

Getting Help

After entering the Setup menu, the first menu you will see is the Main Menu.

Main Menu

The main menu lists the setup functions you can make changes to. You can use the control keys (↑↓) to select the item. The on-line description of the highlighted setup function is displayed at the bottom of the screen.

Sub-Menu

If you find a right pointer symbol (as shown in the right view) appears to the left of certain fields, that means a sub-menu containing additional options can be launched from this field. You can use control keys (↑↓) to highlight the field and press <Enter> to call up the sub-menu. Then you can use the control keys to enter values and move from field to field within a sub-menu. If you want to return to the main menu, just press <Esc >.

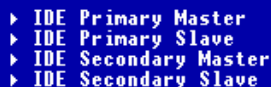

```

▶ IDE Primary Master
▶ IDE Primary Slave
▶ IDE Secondary Master
▶ IDE Secondary Slave

```

General Help <F1>

The BIOS setup program provides a General Help screen. You can call up this screen from any menu by simply pressing <F1>. The Help screen lists the appropriate keys to use and the possible selections for the highlighted item. Press <Esc> to exit the Help screen.

The Main Menu

Once you enter Phoenix-Award® BIOS CMOS Setup Utility, the Main Menu will appear on the screen. The Main Menu allows you to select from twelve setup functions and two exit choices. Use arrow keys to select among the items and press <Enter> to accept or enter the sub-menu.

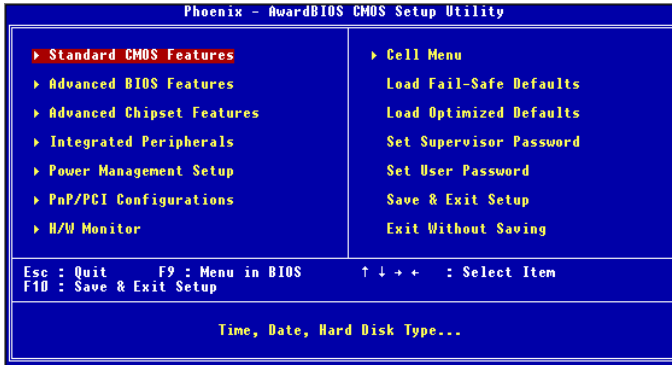

Standard CMOS Features

Use this menu for basic system configurations, such as time, date etc.

Advanced BIOS Features

Use this menu to setup the items of AWARD® special enhanced features.

Advanced Chipset Features

Use this menu to change the values in the chipset registers and optimize your system's performance.

Integrated Peripherals

Use this menu to specify your settings for integrated peripherals.

Power Management Setup

Use this menu to specify your settings for power management.

PNP/PCI Configurations

This entry appears if your system supports PnP/PCI.

H/W Monitor

This entry shows information of your CPU, fan and overall system status.

Cell Menu

Use this menu to specify your settings for CPU/AGP frequency/voltage control and overclocking.

Load Fail-Safe Defaults

Use this menu to load factory default settings into the BIOS for stable system performance operations.

Load Optimized Defaults

Use this menu to load the BIOS values for the best system performance, but the system stability may be affected.

Set Supervisor Password

Use this menu to set Supervisor Password.

Set User Password

Use this menu to set User Password.

Save & Exit Setup

Save changes to CMOS and exit setup.

Exit Without Saving

Abandon all changes and exit setup.

Standard CMOS Features

The items in Standard CMOS Features Menu includes some basic setup items. Use the arrow keys to highlight the item and then use the <PgUp> or <PgDn> keys to select the value you want in each item.

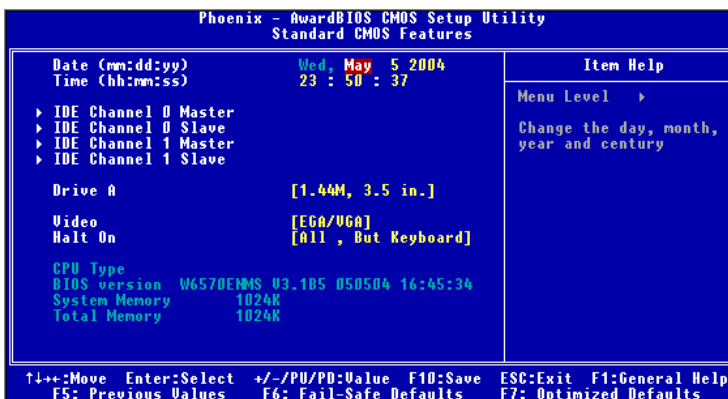

Date

This allows you to set the system to the date that you want (usually the current date). The format is <day><month> <date> <year>.

- day** Day of the week, from Sun to Sat, determined by BIOS. Read-only.
- month** The month from Jan. through Dec.
- date** The date from 1 to 31, can be keyed by numeric function keys.
- year** The year, can be adjusted by users.

Time

This allows you to set the system time that you want (usually the current time). The time format is <hour> <minute> <second>.

IDE Channel 0/1 Master/Slave

Press PgUp/<+> or PgDn/<-> to select [Manual], [None] or [Auto] type. Note that the specifications of your drive must match with the drive table. The hard disk will not work properly if you enter improper information for this category. If your hard disk drive type is not matched or listed, you can use [Manual] to define your own drive type manually.

If you select [Manual], related information is asked to be entered to the following items. Enter the information directly from the keyboard. This information should be provided in the documentation from your hard disk vendor or the system manufacturer.

Access Mode	The settings are CHS, LBA, Large, Auto.
Capacity	The formatted size of the storage device.
Cylinder	Number of cylinders.
Head	Number of heads.
Precomp	Write precompensation.
Landing Zone	Cylinder location of the landing zone.
Sector	Number of sectors.

Drive A

This item allows you to set the type of floppy drive installed. Available options: [None], [360K, 5.25 in.], [1.2M, 5.25 in.], [720K, 3.5 in.], [1.44M, 3.5 in.], [2.88M, 3.5 in.].

Video

The setting controls the type of video adapter used for the primary monitor of the system. Available options are [EGA/VGA], [CGA 40], [CGA 80] and [Mono].

Halt On

The setting determines whether the system will stop if an error is detected at boot. Available options are:

[All Errors]	The system stops when any error is detected.
[No Errors]	The system doesn't stop for any detected error.
[All, But Keyboard]	The system doesn't stop for a keyboard error.
[All, But Diskette]	The system doesn't stop for a disk error.
[All, But Disk/Key]	The system doesn't stop for either a disk or a keyboard error.

CPU Type/BIOS Version/System Memory/Total Memory

The items show the CPU type, BIOS version and memory status of your system (read only).

Advanced BIOS Features

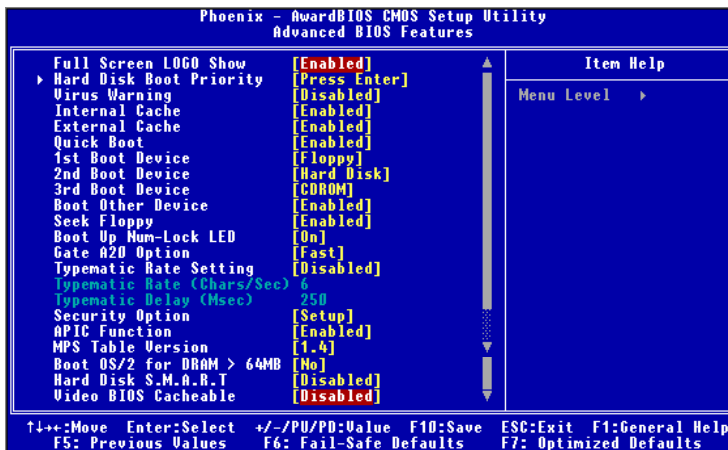

Full Screen LOGO Show

This item enables you to show the company logo on the bootup screen. Settings are:

- [Enabled] Shows a still image (logo) on the full screen at boot.
- [Disabled] Shows the POST messages at boot.

Hard Disk Boot Priority

Press <Enter> to enter the sub-menu. Then you may use the arrow keys (↑↓) to select the desired device, then press <+>, <-> or <PageUp>, <PageDown> key to move it up/down in this hard disk boot priority list.

Virus Warning

The item is to set the Virus Warning feature for IDE Hard Disk boot sector protection. If the function is enabled and any attempt to write data into this area is made, BIOS will display a warning message on screen and beep. Settings: [Disabled] and [Enabled].

Internal Cache

The item allows you to turn on or off CPU's internal (L1) cache. Settings: [Enabled] and [Disabled].

External Cache

The item allows you to turn on or off CPU's external (L2) cache. Settings: [Enabled] and [Disabled].

Quick Boot

Setting the item to [Enabled] allows the system to boot within 5 seconds since it will skip some check items. Available options: [Enabled], [Disabled].

1st/2nd/3rd Boot Device

The items allow you to set the sequence of boot devices where BIOS attempts to load the disk operating system.



MSI Reminds You...

Available settings for "1st/2nd/3rd Boot Device" vary depending on the bootable devices you have installed. For example, if you did not install a floppy drive, the setting "Floppy" does not show up.

Boot Other Device

Setting the option to [Enabled] allows the system to try to boot from other device if the system fails to boot from the 1st/2nd/3rd boot device.

Seek Floppy

Setting to [Enabled] will make BIOS seek floppy drive A: before booting the system. Settings: [Enabled], [Disabled].

Boot Up Num-Lock LED

This setting is to set the Num Lock status when the system is powered on. Setting to [On] will turn on the Num Lock key when the system is powered on. Setting to [Off] will allow users to use the arrow keys on the numeric keypad. Setting options: [On], [Off].

Gate A20 Option

This item is to set the Gate A20 status. A20 refers to the first 64KB of extended memory. When the default value [Fast] is selected, the Gate A20 is controlled by Port92 or chipset specific method resulting in faster system performance. When [Normal] is selected, A20 is controlled by a keyboard controller or chipset hardware.

Typematic Rate Setting

This item is used to enable or disable the typematic rate setting including Typematic Rate & Typematic Delay.

Typematic Rate (Chars/Sec)

After **Typematic Rate Setting** is enabled, this item allows you to set the rate (characters/second) at which the keys are accelerated. Settings: [6], [8], [10], [12], [15], [20], [24], [30].

Typematic Delay (Msec)

This item allows you to select the delay between when the key was first pressed and when the acceleration begins. Settings: [250], [500], [750], [1000].

Security Option

This specifies the type of BIOS password protection that is implemented. Settings are described below:

Option	Description
[Setup]	The password prompt appears only when end users try to run Setup.
[System]	A password prompt appears every time when the computer is powered on or when end users try to run Setup.

APIC Function

This field is used to enable or disable the APIC (Advanced Programmable Interrupt Controller). Due to compliance with PC2001 design guide, the system is able to run in APIC mode. Enabling APIC mode will expand available IRQ resources for the system. Settings: [Enabled], [Disabled].

MPS Table Version

This field allows you to select which MPS (Multi-Processor Specification) version to be used for the operating system. You need to select the MPS version supported by your operating system. To find out which version to use, consult the vendor of your operating system. Settings: [1.4], [1.1].

Boot OS/2 for DRAM > 64MB

This allows you to run the OS/2® operating system with DRAM larger than 64MB. When you choose [Non-OS2], you cannot run the OS/2® operating system with DRAM larger than 64MB. But it is possible if you choose [OS2].

Hard Disk S.M.A.R.T.

This allows you to activate the S.M.A.R.T. (Self-Monitoring Analysis & Reporting Technology) capability for the hard disks. S.M.A.R.T is a utility that monitors your disk status to predict hard disk failure. This gives you an opportunity to move data from a hard disk that is going to fail to a safe place before the hard disk becomes offline. Settings: [Enabled] and [Disabled].

Video BIOS Cacheable

Selecting [Enabled] allows caching of the video BIOS ROM at C0000h to C7FFFh, resulting in better video performance. However, if any program writes to this memory area, a system error may result. Setting options: [Disabled], [Enabled].

Advanced Chipset Features

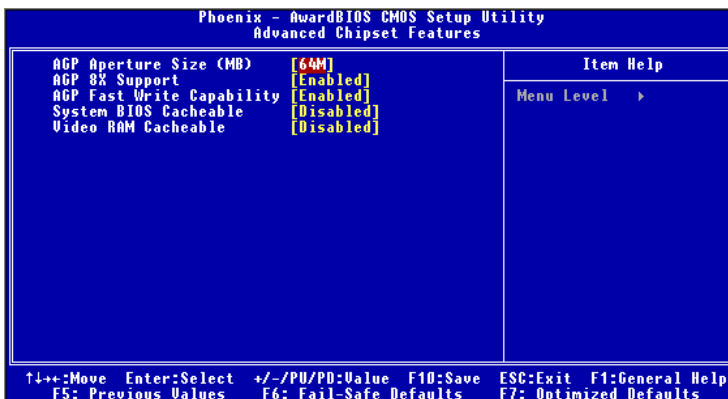

AGP Aperture Size

This setting controls just how much system RAM can be allocated to AGP for video purposes. The aperture is a portion of the PCI memory address range dedicated to graphics memory address space. Host cycles that hit the aperture range are forwarded to the AGP without any translation. The option allows the selection of an aperture size of [32MB], [64MB], [128MB], [256MB] and [512MB].

AGP 8x Support

This item is used to control the functionality of the AGP 3.0 8x interface. Options: *Disabled, Enabled*. Select Enabled only when your card supports this function.

AGP Fast Write Capability

The item enables or disables the AGP Fast Write feature. The Fast Write technology allows CPU to write directly into the graphics controller without passing anything through system memory and improves 8x speed accordingly. Select [Auto] only when your AGP card supports the feature. Options: [Disabled], [Auto].

System BIOS Cacheable

Selecting [Enabled] allows caching of the system BIOS ROM at F0000h-FFFFFh, resulting in better system performance. However, if any program writes to this memory area, a system error may result. Setting options: [Enabled], [Disabled].

Video RAM Cacheable

Selecting [Enabled] allows caching of the video memory (RAM) at A0000h to AFFFFh, resulting in better video performance. However, if any program writes to this memory area, a memory access error may result. Setting options: [Disabled], [Enabled].

Integrated Peripherals

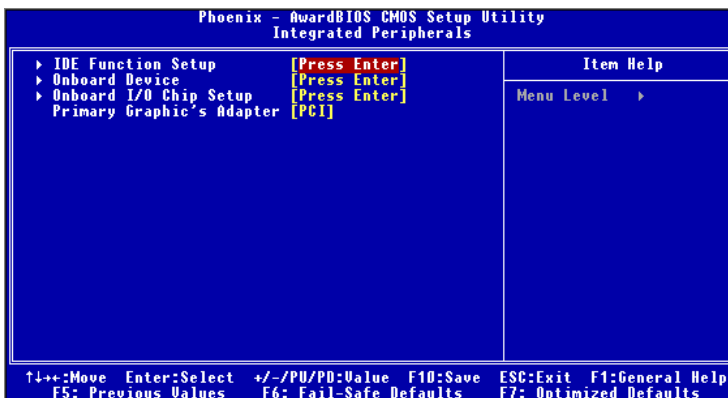

IDE Function Setup

Press <Enter> to enter the sub-menu and the following screen appears:

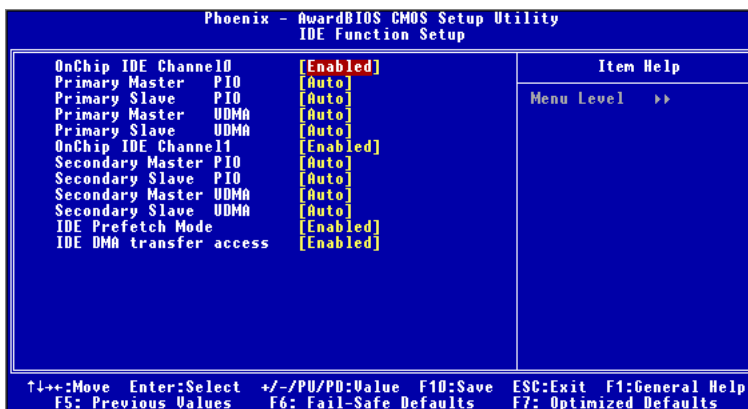

OnChip IDE Channel 0/1

The integrated peripheral controller contains an IDE interface with support for two IDE channels. Choose [Enabled] to activate each channel separately. Settings: [Enabled], [Disabled].

IDE Primary/Secondary Master/Slave PIO

The four IDE PIO (Programmed Input/Output) fields let you set a PIO mode (0-4) for each of the four IDE devices that the onboard IDE interface supports. Modes 0 through 4 provide successively increased performance. In [Auto] mode, the system automatically determines the best mode for each device. The settings are: [Auto], [Mode 0], [Mode 1], [Mode 2], [Mode 3], [Mode 4].

Primary/Secondary Master/Slave UltraDMA

Ultra DMA/33 implementation is possible only if your IDE hard drive supports it and the operating environment includes a DMA driver (Windows 95 OSR2 or a third-party IDE bus master driver). If your hard drive and your system software both support Ultra DMA/33, Ultra DMA/66 and Ultra DMA/100, select Auto to enable BIOS support. The settings are: [Auto], [Disabled].

IDE Prefetch Mode

The onboard IDE drive interface supports IDE prefetching, for faster drive accesses. When you install a primary and/or secondary add-in IDE interface, set this option to [Disabled] if the interface does not support prefetching. The settings are: [Enabled], [Disabled].

IDE DMA Transfer Access

This item is used to enable or disable the DMA transfer function of the IDE Hard Drive. The settings are: [Enabled], [Disabled].

Onboard Device

Press <Enter> to enter the sub-menu and the following screen appears:

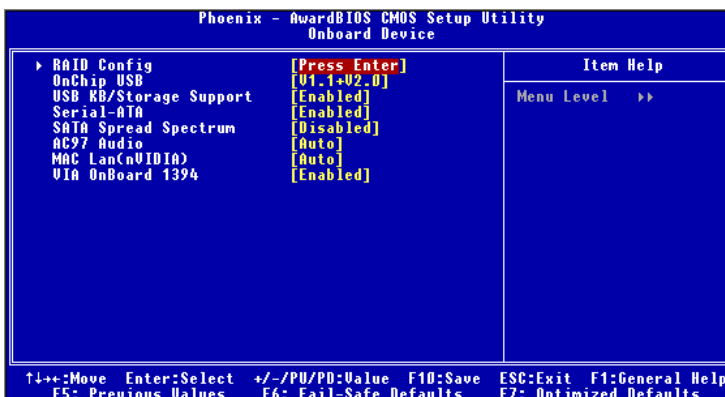

RAID Config

Press <Enter> to enter the sub-menu and the following screen appears:

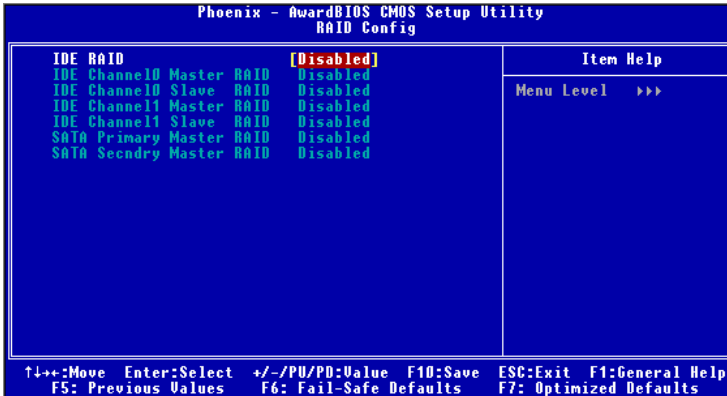

IDE RAID

This item is available for you to enable/disable the onboard IDE RAID function. Setting options: [Enabled], [Disabled].

IDE Channel 0/1 Master/Slave RAID

This feature allows users to enable or disable the RAID function for each IDE hard disk drive. Settings: [Enabled], [Disabled].

SATA Primary/Secondary Master RAID

This feature allows users to enable or disable the RAID function for each SATA hard disk drive. The settings are: [Enabled], [Disabled].

OnChip USB

This setting allows you to enable/disable the onboard USB controller. Selecting [V1.1+V2.0] enables the system to support both USB 1.1 and 2.0 spec. Setting options: [Disabled], [V1.1], [V1.1+V2.0].

USB KB/Storage Support

Select [Enabled] if you need to use a USB-interfaced keyboard or storage device in the operating system. Setting options: [Enabled], [Disabled].

Serial-ATA

This allows you to enable or disable onchip Serial-ATA controller. Settings: [Enabled], [Disabled].

SATA Spread Spectrum

This item is used to enable or disable the SATA clock generator's Spread Spectrum feature. When overclocking the SATA controller, always set it to [Disabled]. Options: [Disabled], [Enabled].

AC97 Audio

[Auto] allows the mainboard to detect whether an audio device is used. If an audio device is detected, the onboard AC'97 (Audio Codec'97) controller will be enabled; if not, it is disabled. Disable the controller if you want to use other controller cards to connect an audio device. The settings are: [Auto], [Disabled].

MAC LAN (nVIDIA)

Setting to [Auto] allows the BIOS to auto-detect the nVIDIA LAN controller and enable it. Setting options: [Auto] and [Disabled].

VIA OnBoard 1394 (Optional)

This item allows you to enable/disable the onboard IEEE1394 controller. The settings are: [Enabled], [Disabled].

Onboard I/O Chip Setup

Press <Enter> to enter the sub-menu and the following screen appears:

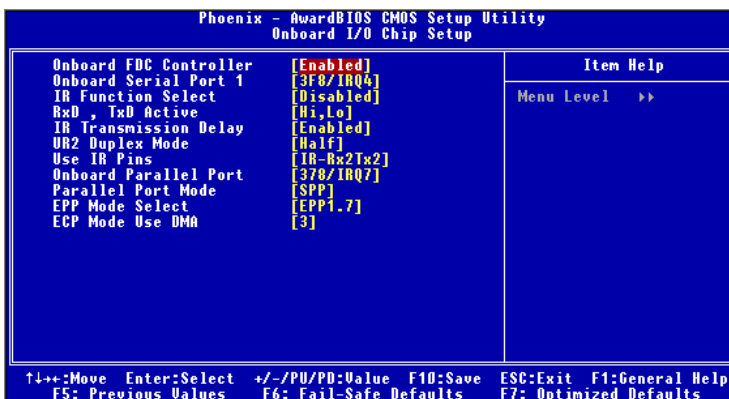

Onboard FDC Controller

Select [Enabled] if your system has a floppy disk controller (FDD) installed on the system board and you wish to use it. If you install add-on FDC or the system has no floppy drive, select [Disabled] in this field. The settings are: [Enabled], [Disabled].

Onboard Serial Port 1

Select an address and corresponding interrupt for the first serial port. The settings are: [3F8/IRQ4], [2E8/IRQ3], [3E8/IRQ4], [2F8/IRQ3], [Disabled], [Auto].

IR Function Select

Select the value required by the IR device connected to the IR port. Full-duplex mode permits simultaneous two-direction transmission. Half-duplex mode

permits transmission in one direction only at a time. If no infrared port is present in the system, select Disabled.

RxD, TxD Active

This setting controls the receiving and transmitting speed of the IR peripheral in use. Setting options: [Hi,Hi], [Hi,Lo], [Lo,Hi], [Lo,Lo].

IR Transmission Delay

This setting determines whether the IR transmission rate will be delayed while converting to receiving mode. Setting options: [Disabled], [Enabled].

UR2 Duplex Mode

This setting controls the operating mode of IR transmission/reception. Setting options: [Full], [Half]. Under [Full] Duplex mode, synchronous, bi-directional transmission/reception is allowed. Under [Half] Duplex mode, only asynchronous, bi-directional transmission/reception is allowed.

Use IR Pins

Please consult your IR peripheral documentation to select the correct setting of the TxD and RxD signals. Setting options: [RxD2/TxD2], [IR-Rx2Tx2].

Onboard Parallel Port

There is a built-in parallel port on the on-board Super I/O chipset that provides Standard, ECP, and EPP features. It has the following options:

[Disabled]	
[3BC/IRQ7]	Line Printer port 0
[278/IRQ5]	Line Printer port 2
[378/IRQ7]	Line Printer port 1

Parallel Port Mode

SPP : Standard Parallel Port

EPP : Enhanced Parallel Port

ECP : Extended Capability Port

ECP + EPP: Extended Capability Port + Enhanced Parallel Port

Normal

SPP/EPP/ECP/ECP+EPP

To operate the onboard parallel port as Standard Parallel Port only, choose [SPP]. To operate the onboard parallel port in the EPP mode simultaneously, choose [EPP]. By choosing [ECP], the onboard parallel port will operate in ECP mode only. Choosing [ECP + EPP] will allow the onboard parallel port to support both the ECP and EPP modes simultaneously. Choose [Normal] to use Standard Parallel Port + Bi-Directional Mode simultaneously.

EPP Mode Select

The onboard parallel port is EPP Spec. compliant, so after the user chooses the onboard parallel port with the EPP function, the following message will be

displayed on the screen: "EPP Mode Select." At this time either [EPP 1.7] spec or [EPP 1.9] spec can be chosen.

ECP Mode Use DMA

The ECP mode has to use the DMA channel, so choose the onboard parallel port with the ECP feature. After selecting it, the following message will appear: "ECP Mode Use DMA." At this time, the user can choose between DMA channel [3] or [1].

Primary Graphic's Adapter

This item specifies which VGA card is your primary graphics adapter. Setting options: [AGP] and [PCI].

Power Management Setup

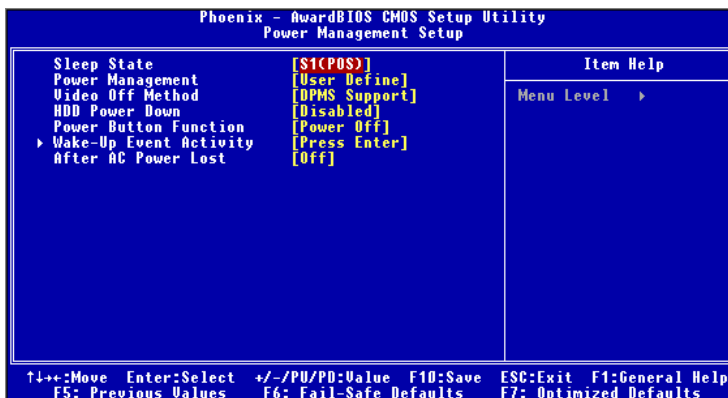

MSI Reminds You...

S3-related functions described in this section are available only when your BIOS supports S3 sleep mode.

Sleep State

This item specifies the power saving modes for ACPI function. If your operating system supports ACPI, such as Windows 98SE/ME/2000/XP, you can choose to enter the Standby mode in S1(POS) or S3(STR) fashion through the setting of this field. Options are:

- | | |
|------------|--|
| [S1 (POS)] | The S1 sleep mode is a low power state. In this state, no system context is lost (CPU or chipset) and hardware maintains all system context. |
| [S3 (STR)] | The S3 sleep mode is a lower power state where the information of system configuration and open applications/files is saved to main memory that remains powered while most other hardware components turn off to save energy. The information stored in memory will be used to restore the system when a "wake up" event occurs. |
| [Auto] | BIOS determines the best mode automatically. |

Power Management

This item is used to select the degree (or type) of power saving and is related to the **HDD Power Down** item. There are three options for power management:

- | | |
|---------------|---|
| [Min Saving] | Minimum Power Management. Suspend Mode=1 Hour |
| [Max Saving] | Maximum Power Management. Suspend Mode=1 Min |
| [User Define] | Allows end users to configure each mode separately. |

Video Off Method

This determines the manner in which the monitor is blanked.

- [V/H SYNC+Blank] This selection will cause the system to turn off the vertical and horizontal synchronization ports and write blanks to the video buffer.
- [Blank Screen] This option only writes blanks to the video buffer.
- [DPMS Support] Initial display power management signalling.

HDD Power Down

If HDD activity is not detected for the length of time specified in this field, the hard disk drive will be powered down while all other devices remain active. Settings are [Disabled] and [1] through [15] Min.

Power Button Function

This feature sets the function of the power button. Settings are:

- [Power Off] The power button functions as normal power off button.
- [Suspend] When you press the power button, the computer enters the suspend/sleep mode, but if the button is pressed for more than four seconds, the computer is turned off.

Wake-Up Event Activity

Press <Enter> and the following sub-menu appears.

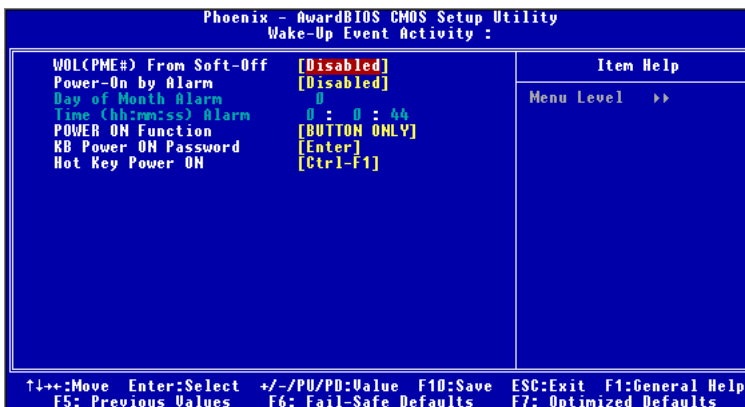

WOL (PME#) From Soft-Off

When set to [Enabled], the feature allows your system to be awakened from the power saving modes through any event on PME (Power Management Event). Settings: [Enabled], [Disabled].

Power-On by Alarm

The field is used to enable or disable the feature of booting up the system on a scheduled time/date. Settings: [Enabled], [Disabled].

Day of Month Alarm

The field specifies the date for *Power-On by Alarm*. Settings: [0]--[31].

Time(hh:mm:ss) Alarm

The field specifies the time for *Power-On by Alarm*. Format is <hour><minute><second>.

POWER ON Function

This controls how the PS/2 mouse or keyboard can power on the system. Settings: [Password], [Hot KEY], [Mouse Left], [Mouse Right], [ANY KEY], [BUTTON ONLY], [Keyboard 98].

KB Power ON Password

If POWER ON Function is set to Password, then you can set a password in the field for the PS/2 keyboard to power on the system.

Hot Key Power ON

If POWER ON Function is set to Hot KEY, you can assign a hot key combination in the field for the PS/2 keyboard to power on the system. Settings: [Ctrl-F1] through [Ctrl-F12].

After AC Power Lost

This setting specifies whether your system will reboot after a power failure or interrupt occurs. Available settings are:

- [Off] Leaves the computer in the power off state.
- [On] Leaves the computer in the power on state.
- [Last State] Restores the system to the status before power failure or interrupt occurred.

PNP/PCI Configurations

This section describes configuring the PCI bus system and PnP (Plug & Play) feature. PCI, or **P**eripheral **C**omponent **I**nterconnect, is a system which allows I/O devices to operate at speeds nearing the speed the CPU itself uses when communicating with its special components. This section covers some very technical items and it is strongly recommended that only experienced users should make any changes to the default settings.

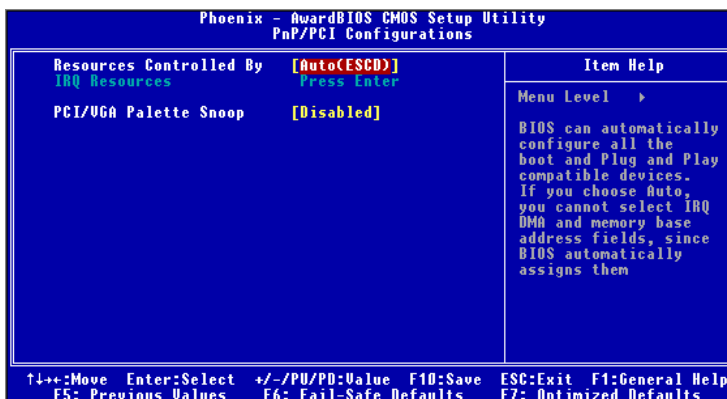

Resource Controlled By

The Award Plug and Play BIOS has the capacity to automatically configure all of the boot and Plug and Play compatible devices. However, this capability means absolutely nothing unless you are using a Plug and Play operating system such as Windows® 95/98. If you set this field to [Manual], choose specific resources by going into each of the sub menu that follows this field (a sub menu is preceded by a "▶"). The settings are: [Auto (ESCD)], [Manual].

IRQ Resources

The items are adjustable only when **Resources Controlled By** is set to [Manual]. Press <Enter> and you will enter the sub-menu of the items. IRQ Resources list IRQ 3/4/5/7/9/10/11/12/14/15 for users to set each IRQ a type depending on the type of device using the IRQ. Settings are:

- | | |
|--------------|---|
| [PCI Device] | For Plug & Play compatible devices designed for PCI bus architecture. |
| [Reserved] | The IRQ will be reserved for further request. |

**MSI Reminds You...**

IRQ (Interrupt Request) lines are system resources allocated to I/O devices. When an I/O device needs to gain the attention of the operating system, it signals this by causing an IRQ to occur. After receiving the signal, when the operating system is ready, the system will interrupt itself and perform the service required by the I/O device.

PCI/VGA Palette Snoop

When set to [Enabled], multiple VGA devices operating on different buses can handle data from the CPU on each set of palette registers on every video device. Bit 5 of the command register in the PCI device configuration space is the VGA Palette Snoop bit (0 is disabled). For example, if there are two VGA devices in the computer (one PCI and one ISA) and the:

VGA Palette Snoop Bit Setting	Action
[Disabled]	Data read or written by the CPU is only directed to the PCI VGA device's palette registers.
[Enabled]	Data read or written by the CPU is directed to both the PCI VGA device's palette registers and the ISA VGA device's palette registers, permitting the palette registers of both VGA devices to be identical.

The setting must be set to [Enabled] if any ISA bus adapter in the system requires VGA palette snooping.

H/W Monitor

This section shows the status of your CPU, fan, overall system status, etc. Monitor function is available only if there is hardware monitoring mechanism onboard.

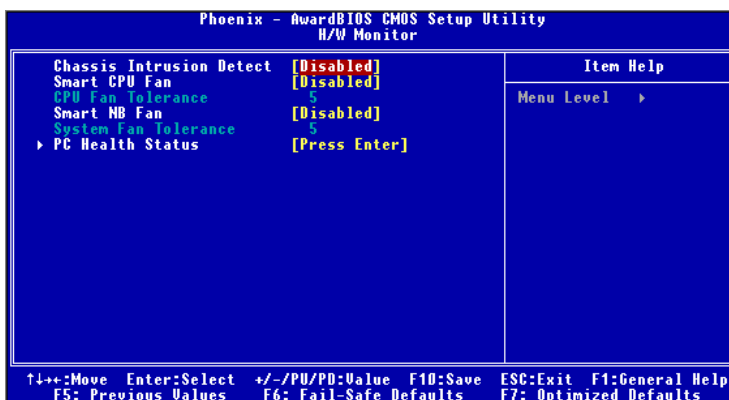

Chassis Intrusion Detect

The field enables or disables the feature of recording the chassis intrusion status and issuing a warning message if the chassis is once opened. To clear the warning message, set the field to [Reset]. The setting of the field will automatically return to [Enabled] later. Setting options: [Enabled], [Reset], [Disabled].

Smart NB/CPU Fan

There are 2 pairs of NB/FAN Speed control: System Temperature with NB Fan, and CPU Temperature with CPU Fan. W83627THF provides the Smart Fan system which can control the fan speed automatically depending on the current temperature to keep it with in a specific range. Settings: [Disabled], [40°C/104°F], [50°C/122°F], [60°C/140°F].

System/CPU Fan Tolerance

You can select a fan tolerance value here for the specific range for the **Smart NB/CPU Fan** items. If the current temperatures of the 2 fans reach the maximum threshold (the temperatures set in the **Smart NB/CPU Fan** plus the tolerance values you set here), the fans will speed up for cooling down. On the contrary if the current temperatures reach the minimum threshold (the set temperatures minus the tolerance values), the fans will slow down to keep the temperatures stable.

PC Health Status

Press <Enter> and the following sub-menu appears.

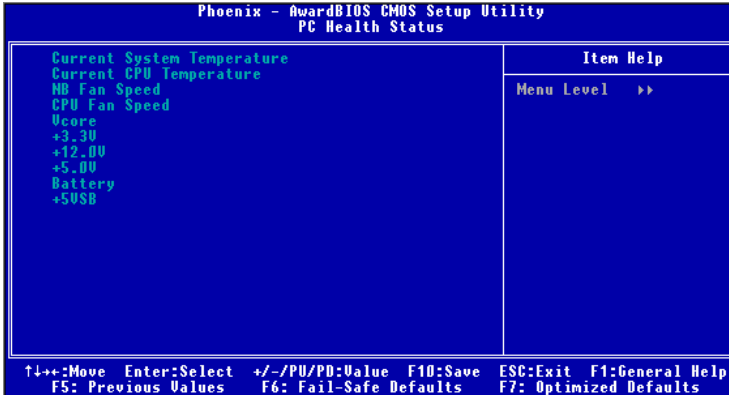

Current System/CPU Temperature, NB/CPU Fan Speed, Vcore, +3.3V, +12.0V, +5.0V, Battery, +5VSB

These items display the current status of all of the monitored hardware devices/components such as CPU voltage, temperatures and all fans' speeds.

Cell Menu

The items in Cell Menu includes some important settings of CPU, AGP, DRAM and overclocking functions.

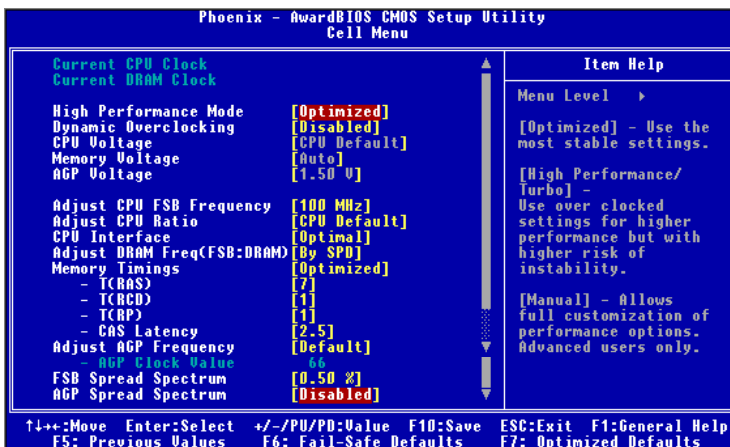

MSI Reminds You...

Change these settings only if you are familiar with the chipset.

Current CPU Clock

It shows the current CPU clock frequency. (Read-only)

Current DRAM Clock

It shows the clock frequency of the installed DRAMs. (read only)

High Performance Mode

This field allows users to control the status of system performance. Users may select [Optimized] for the most stable settings by SPD. [High Performance/Turbo] will increase the system performance but may have instability problems. [Manual] allows full customization of performance options, and is recommended for experts only. Settings: [Optimized], [High Performance/Turbo], [Manual].

Dynamic Overclocking

(D.O.T) Dynamic Overclocking Technology is the automatic overclocking function, included in the MSI™'s newly developed CoreCell™ Technology. It is designed to detect the load balance of CPU while running programs, and to adjust the best CPU frequency automatically. When the motherboard detects CPU is running programs, it will speed up CPU automatically to make the program run smoothly and faster. When

the CPU is temporarily suspending or staying in the low load balance, it will restore the default settings instead. Usually the Dynamic Overclocking Technology will be powered only when users' PC need to run huge amount of data like 3D games or the video process, and the CPU frequency need to be boosted up to enhance the overall performance. Setting options:

[Disabled]	Disable Dynamic Overclocking.
[Private]	1st level of overclocking, increasing the CPU frequency by 1%.
[Sergeant]	2nd level of overclocking, increasing the CPU frequency by 3%. It is also the default value of Load High Performance Defaults .
[Captain]	3rd level of overclocking, increasing the CPU frequency by 5%.
[Colonel]	4th level of overclocking, increasing the CPU frequency by 7%.
[General]	5th level of overclocking, increasing the CPU frequency by 9%.
[Commander]	6th level of overclocking, increasing the CPU frequency by 11%.



MSI Reminds You...

*Even though the Dynamic Overclocking Technology is more stable than manual overclocking, basically, it is still risky. We suggest user to make sure that your CPU can afford to overclock regularly first. If you find the PC appears to be unstable or reboot incidentally, it's better to disable the Dynamic Overclocking or to lower the level of overclocking options. By the way, if you need to conduct overclocking manually, you also need to disable the **Dynamic Overclocking** first.*

CPU Voltage

This item specifies the voltage of CPU Vcore. **Note that changing CPU Vcore could result in the system instability; therefore, it is not recommended to change the default setting for long-term purpose.**

Memory Voltage

Adjusting the DDR voltage can increase the DDR speed. Any changes made to this setting may cause a stability issue, so **changing the DDR voltage for long-term purpose is NOT recommended.**

AGP Voltage Adjust

AGP voltage is adjustable in the field, allowing you to increase the performance of your AGP display card when overclocking, but the stability may be affected.

Adjust CPU FSB Frequency

This setting allows you to select the CPU Front Side Bus clock frequency. Settings: [100MHz] ~ [300MHz] at 1MHz increment.

Adjust CPU Ratio

This setting controls the multiplier that is used to determine the internal clock speed of the processor relative to the external or motherboard clock speed.

CPU Interface

This setting allows you to select the CPU/FSB parameters. Setting: [Optimal], [Aggressive]. When [Aggressive] is selected, the system will use overlocked CPU/FSB parameters. Select [Optimal] for the most stable CPU/FSB parameters.

Adjust DRAM Freq (FSB:DRAM)

This setting controls the ratio of CPU FSB clock & DRAM Frequency to enable the CPU & DRAM to run at different frequency combinations. Please note that the setting options vary according to the CPU FSB clock preset. Options: [By SPD], [2:1], [5:3], [3:2], [4:3], [5:4], [6:5], [1:1], [5:6], [4:5], [3:4], [2:3], [3:5], [1:2], [Auto].

Memory Timings

Selects whether DRAM timing is controlled by the SPD (Serial Presence Detect) EEPROM on the DRAM module. Setting to [Optimized] enables DRAM timings to be determined by BIOS based on the configurations on the SPD. [High Performance/Turbo] will increase the system performance but may have instability problems. Selecting [Manual] allows users to configure the DRAM timings manually. Options: [Optimized], [High Performance/Turbo], [Manual].

T-(RAS)

This setting controls the number of clock cycles for DRAM to be allowed to precharge from the active state. Settings: [1] through [15].

T-(RCD)

When DRAM is refreshed, both rows and columns are addressed separately. This setup item allows you to determine the timing of the transition from RAS (row address strobe) to CAS (column address strobe). The less the clock cycles, the faster the DRAM performance. Setting options: [1] through [7].

T-(RP)

This item controls the number of cycles for Row Address Strobe (RAS) to be allowed to precharge. If insufficient time is allowed for the RAS to accumulate its charge before DRAM refresh, refresh may be incomplete and DRAM may fail to retain data. This item applies only when synchronous DRAM is installed in the system. Available settings: [1] through [7].

CAS Latency

The field controls the CAS latency, which determines the timing delay before RAM starts a read command after receiving it. Setting options are: [2.0], [2.5] and [3.0]. [2.0]T increases system performance while [3.0]T provides more stable system performance.

AGP Clock Control

This item allows users to set the AGP clock manually or by default. Options: [Default], [Manual].

AGP Clock Value

When AGP Clock Control is set to [Manual], users can key in a DEC number between [66] and [120].

FSB Spread Spectrum

This item is used to enable or disable the FSB clock generator's Spread Spectrum feature. When overclocking the FSB, always set it to [Disabled]. Options: [Disabled], [0.50%], [1.00%].

AGP Spread Spectrum

This item is used to enable or disable the AGP clock generator's Spread Spectrum feature. When overclocking the AGP slot, always set it to [Disabled]. Options: [Disabled], [0.50%].

Load Fail-Safe/Optimized Defaults

The two options on the main menu allow users to restore all of the BIOS settings to the Fail-Safe or Optimized Defaults. The Optimized Defaults are the default values set by the mainboard manufacturer specifically for optimal performance of the mainboard. The Fail-Safe Defaults are the default values set by the BIOS vendor for stable system performance.

When you select Load Fail-Safe Defaults, a message as below appears:

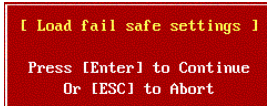

[Load fail safe settings]
Press [Enter] to Continue
Or [ESC] to Abort

Pressing Y loads the BIOS default values for the most stable, minimal system performance.

When you select Load Optimized Defaults, a message as below appears:

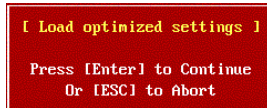

[Load optimized settings]
Press [Enter] to Continue
Or [ESC] to Abort

Pressing Y loads the default factory settings for optimal system performance.

Set Supervisor/User Password

When you select this function, a message as below will appear on the screen:

Enter Password:

Type the password, up to six characters in length, and press <Enter>. The password typed now will replace any previously set password from CMOS memory. You will be prompted to confirm the password. Retype the password and press <Enter>. You may also press <Esc> to abort the selection and not enter a password.

To clear a set password, just press <Enter> when you are prompted to enter the password. A message will show up confirming the password will be disabled. Once the password is disabled, the system will boot and you can enter Setup without entering any password.

When a password has been set, you will be prompted to enter it every time you try to enter Setup. This prevents an unauthorized person from changing any part of your system configuration.

Additionally, when a password is enabled, you can also have Award BIOS to request a password each time the system is booted. This would prevent unauthorized use of your computer. The setting to determine when the password prompt is required is the *Security Option* of the *ADVANCED BIOS FEATURES* menu. If the *Security Option* is set to *System*, the password is required both at boot and at entry to Setup. If set to *Setup*, password prompt only occurs when you try to enter Setup.



MSI Reminds You...

About Supervisor Password & User Password:

Supervisor password: Can enter and change the settings of the setup menu.

User password: Can only enter but do not have the right to change the settings of the setup menu.



Introduction to DigiCell

DigiCell, the most useful and powerful utility that MSI has spent much research and efforts to develop, helps users to monitor and configure all the integrated peripherals of the system, such as audio program, power management, MP3 files management and communication / 802.11g WLAN settings. Moreover, with this unique utility, you will be able to activate the MSI well-known features, Live Update and Core Center, which makes it easier to update the BIOS/drivers online, and to monitor the system hardware status (CPU/Fan temperature and speed) or to overclock the CPU/memory.

Once you have your DigiCell installed (locate the setup source file in the setup CD accompanying with your mainboard, path: **Utility --> MSI Utility --> MSI DigiCell**), it will have an icon  in the system tray, a short cut icon on the desktop, and a short cut path in your "Start-up" menu. You may double-click on each icon to enable DigiCell.



short-cut icon in the system tray



short-cut path in the start-up menu
(path: Start-->Programs-->MSI-->DigiCell)

Main

Before using this utility, it is required to have all the integrated peripherals/cards (LAN card, Wireless LAN card, MegaStick... etc.) and all the necessary drivers (onboard LAN driver, audio driver, CoreCenter, Live Update... etc.) installed correctly.

The icon representing each item will be lit up if it is inserted/installed correctly and properly. Otherwise, the icon will remain gray and user is not able to view the functionality/connection of that item.

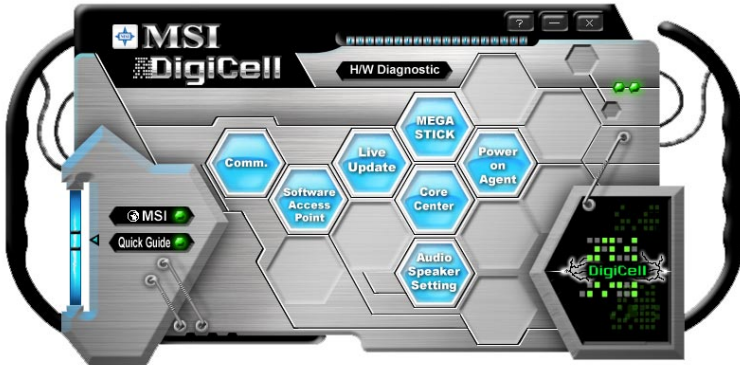

Introduction:

Click on each icon appearing above to enter the sub-menu to make further configuration.

MSI

Click on this button to link to MSI website:

<http://www.msi.com.tw>.

Quick Guide

Click on this button and the quick guide of **DigiCell** will be displayed for you to review.

H/W Diagnostic

In this sub-menu, it provides the information of each DigiCell button for you to check if the representing peripherals/cards/drivers are correctly installed.

Comm.

In this sub-menu, you can see the configuration details for communication products, including the status, strength, speed and channel of the connection of the Ethernet LAN & Wireless LAN.

Software Access Point

In this sub-menu, you can change your connection mode, and configure the advanced settings for each mode, such as the authentication encryption... etc.

Live Update

You can take advantage of **Live Update** to detect and update BIOS and drivers online.

Core Center

You can take advantage of **Core Center** to monitor the health status of your system and to overclock under Windows OS if your system supports overclocking function.

MEGA STICK

If you have your MEGA STICK connected to your system, this icon will be lit up. Click this blue icon to turn DigiCell into a MP3 player, and then you can load media files from your MEGA STICK or the system, and edit the preferred playlist.

Audio Speaker Setting

In this sub-menu, you can configure and test the multi-channel audio function, speakers, sound effect and environment.

Power on Agent

In this sub-menu, you can configure date, time and auto-executed programs of the power-on, power-off and restart features.



MSI Reminds You...

*Click on **back** button in every sub-menu and it will bring you back to the main menu.*

H/W Diagnostic

In the **H/W Diagnostic** sub-menu, you can see the information, status and note of each DigiCell. You may double check the connection and installation of the item marked as gray.

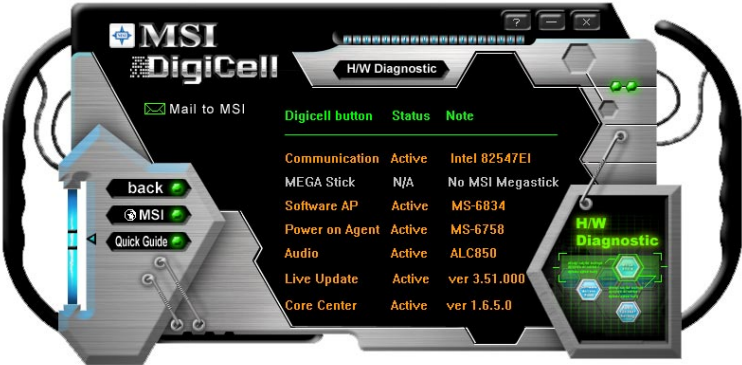

You may also click on the **Mail to MSI** button to send your questions or suggestions to MSI's technical support staff.

Communication

In the **Communication** sub-menu, you can see the status of all the LAN / WLAN / Bluetooth on the screen if the hardware is installed. The first icon indicates the onboard LAN on your system, the second icon indicates the wireless LAN status, and the third one is the information about the bluetooth on your system. Click on each item for details.

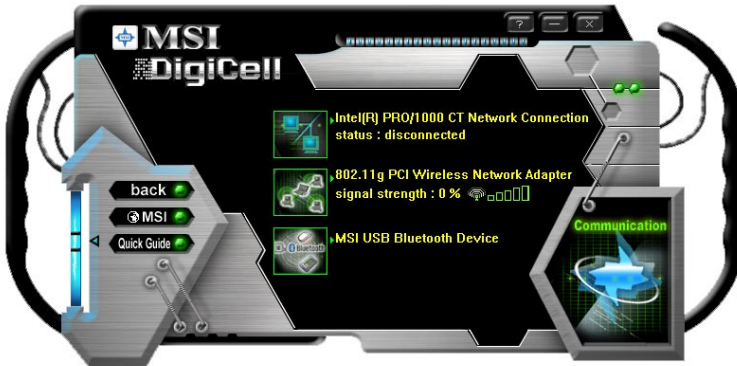

This icon indicates the information and connection status of onboard LAN, which is read-only.



The second icon indicates the wireless connection. You may click this icon to configure the advanced settings in the **WLAN Card Mode** dialogue box (see the image on p.4-8). Please note that it is only available when the **Software Access Point** is set to **WLAN Card Mode**.



The third icon indicates the connection using bluetooth devices. If your system is connected to a bluetooth device, the icon will light up.

Software Access Point

In the **Software Access Point** sub-menu, you can see the communication status on your system and choose the desired software access point mode by clicking on the desired icon. The default settings are configured for your usage. The default software access point mode is set to **WLAN Card Mode**. For more advanced security settings and channels switching, click on “**Setting**” button to enter its sub-menu.

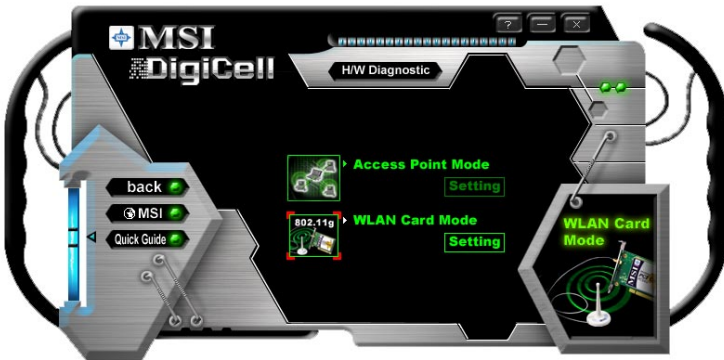

Terminology

Here are the introduction of WLAN / AP communication terminology.

WEP Key

In the wireless network environment, the administrator can set up password (Network Key) to protect the network from being attacked or unauthorized access. When building the network, you can set up 4 sets of WEP keys, which can be 5 characters (10 hexadecimal digital) or 13 characters (26 hexadecimal digital) and specify one of them to use.

Ad-hoc Mode

An Ad-hoc network is a local area network or other small network, especially one with wireless or temporary plug-in connections, in which some of the network devices are part of the network only for the duration of a communications session. Users in the network can share files, print to a shared printer, and access the Internet with a shared modem. In this kind of network, new devices can be quickly added; however, users can only communicate with other wireless LAN computers that are in this wireless LAN workgroup, and are within range.

Infrastructure Mode

The difference between Infrastructure network and Ad-hoc network is that the former one includes an Access Point. In an Infrastructure network, the Access Point can manage the bandwidth to maximize bandwidth utilization. Additionally, the Access Point enables users on a wireless LAN to access an existing wired network, allowing wireless users to take advantage of the wired networks resources, such as Internet, email, file transfer, and printer sharing. The scale and range of the Infrastructure networking are larger and wider than that of the Ad-hoc networking.

Access Point Mode

Click on “**Setting**” button of the **Access Point Mode** and the following screen will display.



IP Sharing

Click on this icon to enable/disable the IP sharing. The default of this setting is disabled.



Disabled.



Enabled.

Enabling/disabling IP sharing depends on the different situation. For example:

1. If your family and you are getting on Internet at home with multi computers, and your ISP only provides one IP for you, you may need to enable **IP Sharing** function in order to use this one IP to get on Internet with multi computers simultaneously.
2. If you are getting on Internet in office, usually the LAN card will automatically get the IP this computer uses. In this case you don't have to enable this function.

SSID

Means Service Set Identifier, a **unique** name shared among all points in a wireless network. It must be **identical** for all points in the network. Then the card will be able to connect to an access point with the same SSID.

Channel

Specifies the operating radio frequency channel in **Infrastructure mode**, which should be set to an available one (ex: with less traffic to ensure the stable and better connection).

Associated Client List

This option is to display information of stations that are currently associated to your wireless gateway.

Association Control

This option allows you to control which PC can connect to the wireless LAN. If you

enable this feature, only PCs with MAC address located in Association Control List can connect to the wireless LAN.

MAC Address

MAC stands for Media Access Control. A MAC address is the hardware address of a device connected to a network.

Security

This option allows you to enable/disable the authentication function.

Authentication

Open: Communicates the key across the network.

Shared: Devices must have identical WEP settings to communicate.

WLAN Card Mode

Click on “**Setting**” button of the **WLAN Card Mode** for the WEP status of your APs.

If the AP you are selecting (the highlighted one) is not encrypted (**Disabled** shown in the **Encryption** column), the screen will display as below. You can click “**Connect**” to make connection to that AP, click “**Cancel**” to close this dialogue box, or click “**Refresh**” button to update the available WLAN connections.

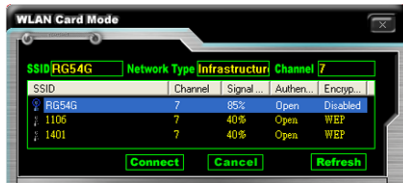

If the network you are selecting is encrypted (**WEP** shown in the **Encryption** column), the screen will display as below. You need to enter the correct WEP key defined by AP in the specified **WEP Key 1~4** fields to make the connection.

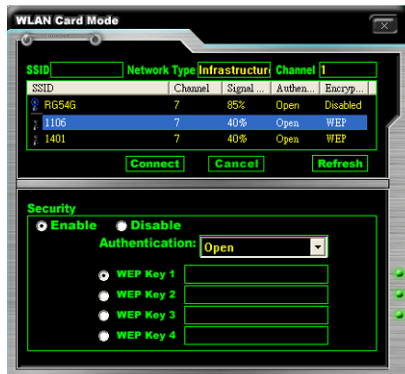

Live Update

Click on the **Live Update** icon in the main menu and the **Live Update** program will be enabled.

The Live Update 3™ is a tool used to detect and update your BIOS/drivers/VGA BIOS/VGA Driver/OSD/Utility online so that you don't need to search for the correct BIOS/driver version throughout the whole Web site. To use the function, you need to install the "MSI Live Update 3" application. After the installation, the "MSI Live Update 3" icon (as shown on the right) will appear on the screen.

Double click the "MSI Live Update 3" icon, and the following screen will appear:

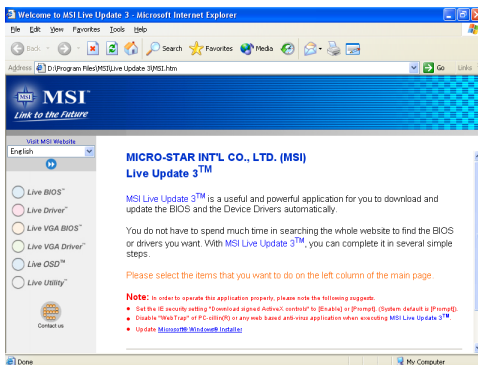

Six buttons are placed on the left column of the screen. Click the desired button to start the update process.

Live BIOS – Updates the BIOS online.

Live Driver – Updates the drivers online.

Live VGA BIOS – Updates the VGA BIOS online.

Live VGA Driver – Updates the VGA driver online.

Live OSD – Updates the firmware of the OSD products online.

Live Utility – Updates the utilities online.

If the product you purchased does not support any of the functions listed above, a "sorry" message is displayed. For more information on the update instructions, insert the companion CD and refer to the "Live Update Guide" under the "Manual" Tab.

MEGA STICK

In the **MEGA STICK** sub-menu, you can configure the settings of MSI MEGA STICK and the media files (*.m3u, *.mp3, *.wav, *.cda, *.wma) on your system.



Basic Function

Here you can edit your own play list with the buttons “load”, “save”, “delete”, “shuttle”, “repeat” & “print”.

load save delete shuttle repeat print

- Load** To load media files or the playlist of mp3 files (*.m3u) on your system or on your MEGA STICK.
- Save** To save a loaded playlist of mp3 files (*.m3u) on your system or on your MEGA STICK.
- Delete** Click on the media files in the **Play List:** field and use “Delete” button to remove the media file from the play list. You may remove multi media files simultaneously by using “Ctrl” to select multi files.
- Shuffle** To play the media file in the **Play List:** in a random order.
- Repeat** To repeat the selected files in the **Play List:**.
- Print** This button has 2 functions:
1. To print out the details of current play list through your printer with the following information:
Song title --- Song length --- Singer name
 2. To save the details of current play list and save the file in the plain text file format in the \\Program files\MSI\DigiCell\MyMusic.txt for your reference. The *MyMusic.txt* file is with the following information:
Song title --- Song length --- Singer name

There is also a toolbar for you to execute some basic function, like play, stop, pause, previous/next song, song info and volume adjust. There is also a scroll bar on the top for you to forward/rewind.

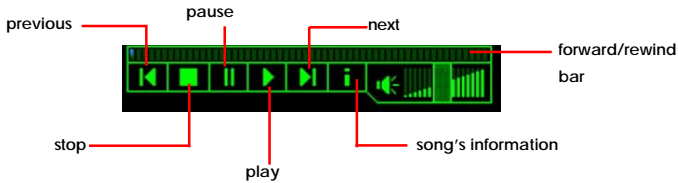

Right-click on the MP3 file and choose “Info”, a **MP3 Info** dialogue will pop up to show the information of the file, including the title, artist, album, release year and others. You may also add your own comment in the **comment** field. Then click “Save” to save the changes, click “Cancel” to discard the changes, or click “Remove” to remove all information.



Non-Unicode programs supported

If you are using an operating system in European languages, and you'd like to play the media files in MEGA STICK with East-Asian languages (such as Chinese, Japanese... etc.), it is possible that the file names will display incorrectly.

You can install the **Supplemental Language Support** provided by Microsoft to solve this problem. You need to have your Microsoft Setup CD prepared in the CD-ROM. The system will start to install the necessary components after the settings are configured here. Follow the steps described below.

1. Go to [Control Panel] and choose [Regional and Languages Options].

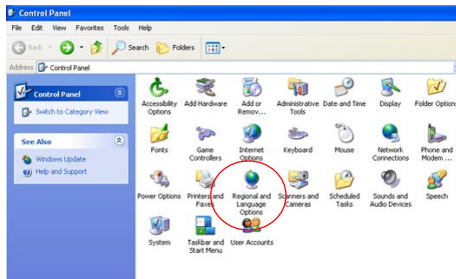

2. Go to the [Languages] tab and enable the check box of [Install files for East Asian languages]. A dialogue box will pop up to remind you the above selection is chosen.

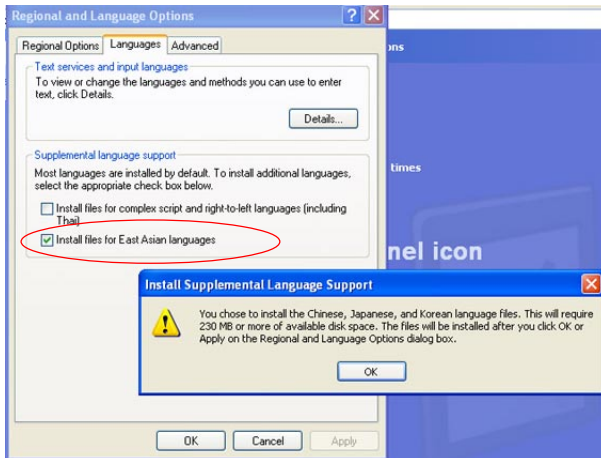

- Then go to the [Advanced] tab and select **the language you want to be supported** (the language of the filename in the MegaStick) from the drop-down list in the [Language for non-Unicode programs], then click [Apply]. The system will install the necessary components from your Microsoft Setup CD immediately.

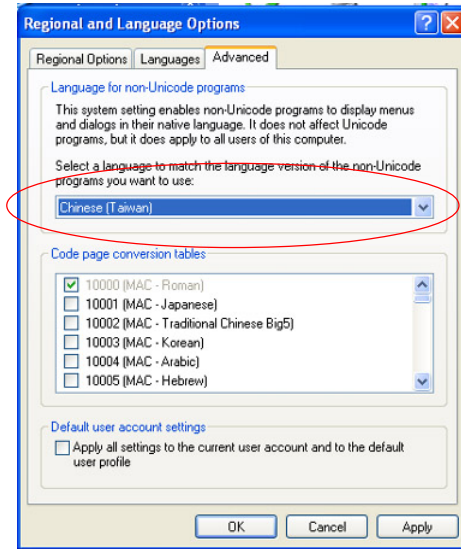

Core Center (for AMD K7 CPU)

Click on the **Core Center** icon in the main menu and the **Core Center** program will be enabled.

CoreCenter is just like your PC doctor that can detect, view and adjust the PC hardware and system status during real time operation.

In the left side it shows the current system status including the Vcore, 3.3V, +5V and 12V. In the right side it shows the current PC hardware status such as the CPU & system temperatures and all fans speeds.

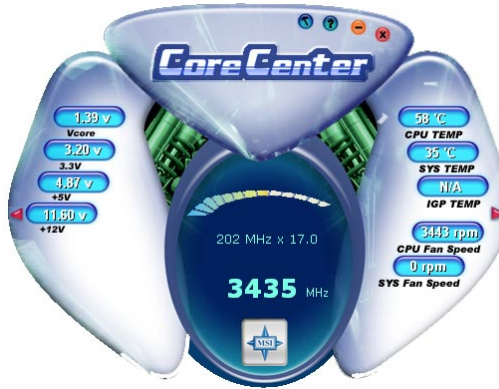

When you click the red triangles in the left and right sides, two sub-menus will open for users to adjust the thresholds of system to send out the warning messages.



Left-wing: Current system status

In the left sub-menu, you can configure the settings of FSB, Vcore, Memory Voltage and AGP Voltage by clicking the radio button next to each item and make it available (the radio button will be lighted as yellow when selected), use the “+” and “-” buttons to adjust, then click “**OK**” to apply the changes. Then you can click “**Save**” to save the values you just configured.

Also you may click “**Auto**” to start testing the maximum CPU overclocking value. The CPU FSB will automatically increase the testing value until the PC reboots. Or you may click “**Default**” to restore the default values.

Right-wing: PC hardware status during real time operation

In the right sub-menu, you can configure the PC hardware status such as CPU & system temperatures and fan speeds. You may use the scroll bars to adjust each item, then click “**OK**” to apply the changes. The values you set for the temperatures are the maximum thresholds for the system warnings, and the value for fan speeds are the minimum thresholds.

Audio Speaker Setting

In the **Audio Speaker Setting** sub-menu, you can configure the multi-channel audio operation, perform speaker test, and choose the environment you prefer while enjoying the music.

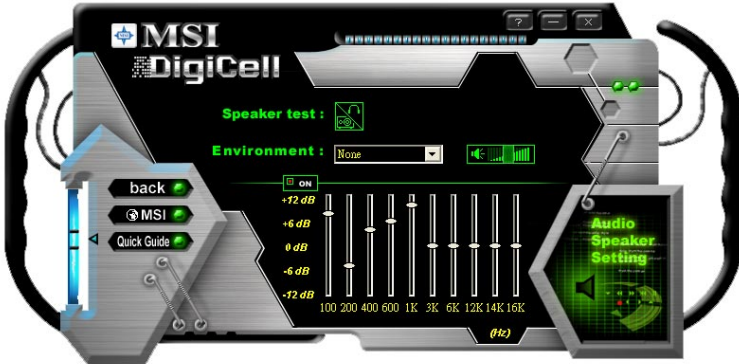

You can scroll the bar of each equalizer to regulate the current playing digital sound source. Also you may click on the “on” button to enable/disable the equalizer function. Once the equalizer function is enabled, you can choose several preset equalizers for your preference. You may also right-click anywhere to execute this function. After you have chosen one equalizer, it will be indicated next to the “on” button in yellow.

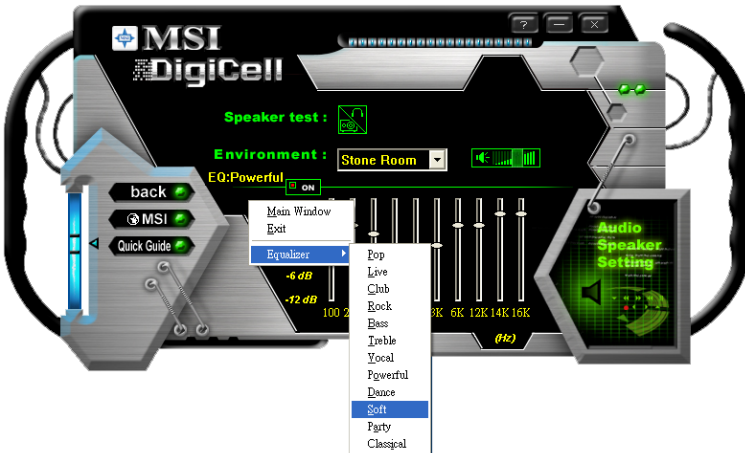

The **Environment** setting lets you select the environment you like, such as **Cave** or **Convert Hall**.

Click on the “**Speaker test**” button and the following dialogue box will appear:

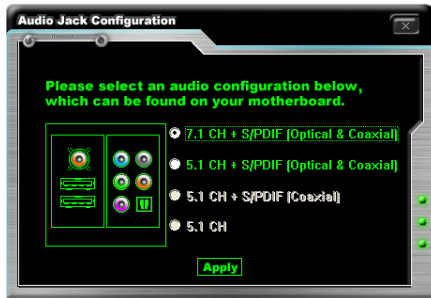

In this **Speaker Configuration** dialogue box, select the audio configuration which is identical to the audio jack on your mainboard. Once the correct audio configuration is selected, click “**Apply**” to save the changes. Then the following screen will appear. In this **Speaker Configuration** dialogue box, first select the correct item from the **Speaker mode** drop-down list, and then click on each connected speaker to ensure if Headphone, 2-, 4-, 5.1-, or 7.1- channel audio operation is working properly. If any speaker fails to make sound, then check whether the cable is inserted firmly to the connector, or replace the bad speakers with good ones.

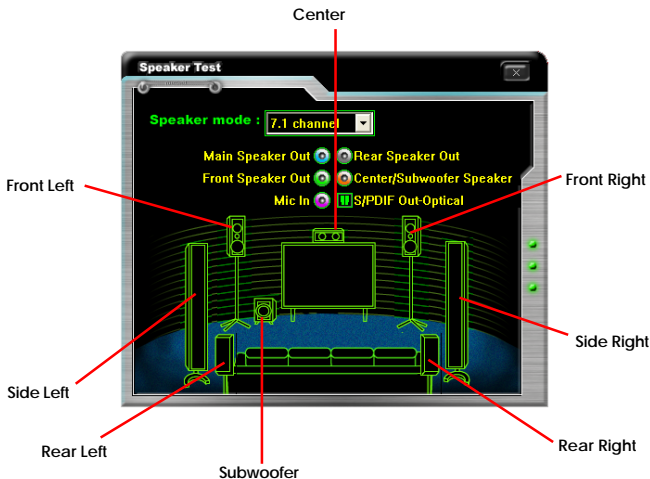

Power on Agent

In the **Power on Agent** sub-menu, you can configure setting of power-on, power-off and restart status.

In the screen below, you can set the date, time, start-up programs respectively for power-on, power-off and restart.

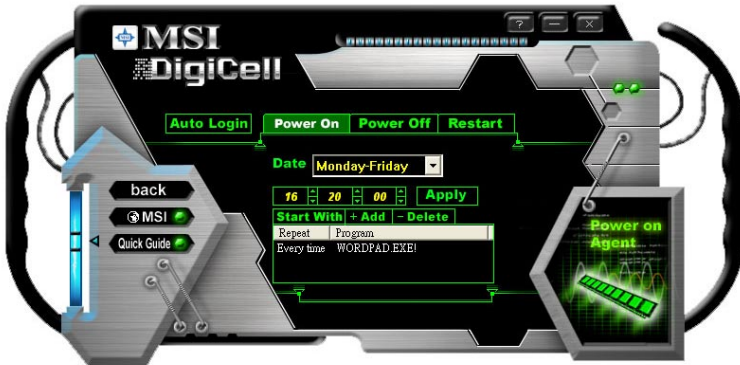

Power On

Here are the available settings for **Power On** function:

- Date** Use the drop-down list to select the date for power-on.
- Time** Use the arrow keys to select the hour/minute/second for power-on, power-off and restarting. Then click **“Apply”** to save the changes. As you click **“Apply”**, the following dialogue will appear to show you the next power-on schedule, and the system will start to count down to restart. Click **“OK”** to restart the computer right away or click **“Later”** to restart your computer later.

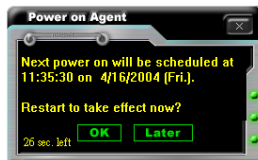

MSI Reminds You...

Please note that the new setting will not take effect until you restart your computer.

Power Off / Restart

You may configure the time (in the format hh:mm:ss) for the next power-off / restart.

Start With

Use the button “+Add” to add the start-up programs as DigiCell is activated next time. For example, you may like to have Outlook activated or a specified website linked when you get to the office every morning.

Step 1: Click on the **Program:** field and click “>>” button to browse for the path of Outlook or Internet Explorer.

Step 2: Click on “**OK**” to apply the setting.

Step 3: For specified file or specified website, you may enter the file name with the complete path or the website link in the **Parameters:** field.

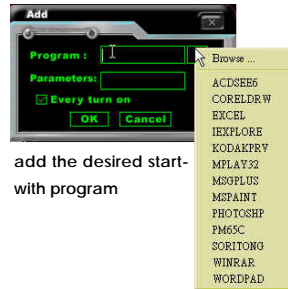

add the desired start-up with program



To activate Outlook as DigiCell is enabled next time



To activate a specified website as DigiCell is enabled next time

Of course you may use the button “-Delete” to remove the added programs, or you can right-click on the selected program and click **Delete**.



delete the added program



MSI Reminds You...

You can also enable the **Every turn on** function, which will enable the specified program(s) and file(s) every time the Digi Cell utility runs.

Auto Login

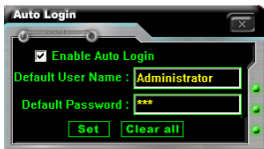

Since the **Power On** function allows the system to power on automatically, you may have to enable this **Auto Login** function in the following situations:

1. If you are using a computer belonging to a domain in office, and you need to enter your user name & password everytime when you boot up your computer.
2. If there are multi users using the same computer and you'd like to power on the computer automatically with one specific user.

Enable Auto Login

Enable this setting if you want to use the **Auto Login** feature. It supports the following operating systems: Win9X, Windows ME, Windows 2000 & Windows XP.

Default User Name

It is only available for Windows 2000 & Windows XP.

- If you are using a computer belonging to a domain in office, please enter your login user name in this field.
- If you are using a computer with multi users (for Windows XP operating system), please enter the user name you'd like to auto power-on in this field.

Default Password

It is only available for Windows 2000 & Windows XP.

- If you are using a computer belonging to a domain in office, please enter your login password in this field.
- If you are using a computer with multi-users (for Windows XP operating system), please enter the password for the user name you'd like to auto power-on in this field.

A thick, horizontal blue brushstroke graphic that spans across the width of the page, positioned below the number 5 logo and above the title.

nVidia RAID Introduction

NVIDIA brings Redundant Array of Independent Disks (RAID) technology—which is used by the world's leading businesses—to the common PC desktop. This technology uses multiple drives to either increase total disk space or to offer data protection. For all levels, RAID techniques optimize storage solutions by using multiple disks grouped together and treating them as a single storage resource.

Introduction

System Requirement

Operating System Support

NVRAID supports the following operating systems:

- Windows XP Home Edition
- Windows XP Professional Edition
- Windows 2000 Professional

RAID Arrays

NVRAID supports the following types of RAID arrays described in this section:

RAID 0: RAID 0 defines a disk striping scheme that improves the disk read and write times for many applications.

RAID 1: RAID 1 defines techniques for mirroring data.

RAID 0+1: RAID 0+1 combines the techniques used in RAID 0 and RAID 1 arrays.

Spanning (JBOD): JBOD provides a method for combining drives of different sizes into one large disk.

Summary of RAID Configurations

Array	Uses	Advantages	Drawbacks	# Hard Disks	Fault Tolerance
RAID 0	Non-critical data requiring high performance.	High data throughput.	No fault tolerance.	multiple	None
RAID 1	Small databases or any other small capacity environment requiring fault tolerance.	100% data redundancy.	Requires 2 drives for the storage space of 1 drive.	2	Yes
RAID 0+1	Critical data requiring high performance.	Optimized for both 100% data redundancy and performance. Allows spare disks.	Requires 2 drives for the storage space of 1 drive—the same as RAID level 1.	4+	Yes
JBOD	Combining odd size drives into one big drive	Combines and uses the capacity of odd size drives.	Decreases performance because of the difficulty in using drives concurrently or to optimize drives for different uses.	Multiple	No



MSI Reminds You...

Please note that users cannot install OS, either WinME or Win98, in their SATA hard drive. Under these two OSs, SATA can only be used as a normal storage device.

RAID Configuration

Basic Configuration Instructions

The following are the basic steps for configuring NVRAID:

Non-Bootable RAID Array

1. Choose the hard disks that are to be RAID enabled in the system BIOS. (Check p. 3-13 for details.)
2. Specify the RAID level, either Mirroring (RAID 1), Striping (RAID 0), Striping and Mirroring (RAID 0+1), or Spanning (JBOD) and create the desired RAID array.
3. Enter the Windows OS, run the Windows nForce Setup application and install the RAID software. (Check p.5-7 for details.)
4. Initialize the NVRAID Array Disks.

Bootable RAID Array

1. Choose the hard disks that are to be RAID enabled in the system BIOS. (Check p. 3-13 for details.)
2. Specify the RAID level, either Mirroring (RAID 1), Striping (RAID 0), Striping and Mirroring (RAID 0+1), or Spanning (JBOD) and create the desired RAID array.
3. Boot from the Windows CD, use the floppy disk that has the RAID driver to copy and install the nForce RAID software. (Check p.5-7 for details.)
4. Initialize the NVRAID Array Disks.

Setting Up the NVRAID BIOS

Be sure to enable the **SATA Primary/Secondary/Master RAID** items in **RAID Config of Integrated Peripherals/Onboard Devices** in BIOS (refer to p.3-13 for details) before configuring the NVRAID BIOS. After that press F10 to save the configuration and exit. The PC will reboot right away. Then enter the RAID BIOS Setup by pressing **F10** when prompted, and follow the procedures described below to set up the NVRAID BIOS.

NVRAID BIOS setup lets you choose the RAID array type and which hard drives you want to make part of the array.

Entering the RAID BIOS Setup

1. After rebooting your PC, wait until you see the RAID software prompting you to press **F10**. The RAID prompt appears as part of the system POST and boot process prior to loading the OS.
2. Press **F10**, and the NVIDIA RAID Utility --- **Define a New Array** window will appear.

The default **RAID Mode** is set to **Mirroring** and **Striping Block** is set to **Optimal**.

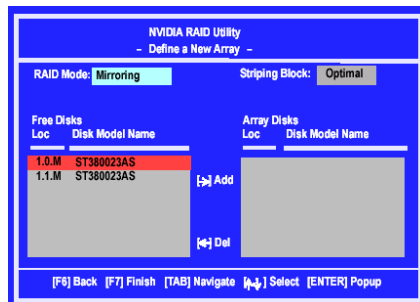

Understanding the “Define a New Array” Window

Use the Define a New Array window to

- Select the RAID Mode
- Set up the Striping Block
- Specify which disks to use for the RAID Array

Depending on the platform used, the system can have one or more channels. In a typical system there is usually one controller and multiple channels, and each channel has a slave and a master.

The channel/controller/master/slave status of each hard disk is given in the Loc (location) columns of the Free Disks and Array Disks lists.

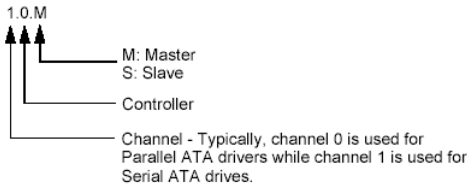

In the example above, 1.0.M means the hard drive is attached to Channel 1, Controller 0, and the drive is set to Master. The following is a list of all possible combinations:

Parallel ATA

- 0.0.M Channel 0, controller 0, Master
- 0.0.S Channel 0, controller 0, Slave
- 0.1.M Channel 0, controller 1, Master
- 0.1.S Channel 0, controller 1, Slave

Serial ATA

- 1.0.M Channel 1, controller 0, Master
- 1.1.M Channel 1, controller 1, Slave



MSI Reminds You...

There is no such thing as Slave drive in Serial ATA. All drives are considered to be Master since there is a one to one connection between the drive and the controller.

Using the Define a New Array Window

If necessary, press the tab key to move from field to field until the appropriate field is highlighted.

- **Selecting the RAID Mode**

By default, this is set to [Mirroring]. To change to a different RAID mode, press the down arrow key until the mode that you want appears in the RAID Mode box—either [Mirroring], [Striping], [Spanning], or [Stripe Mirroring].

- **Selecting the Striping Block Size**

Striping Block size is given in kilobytes, and affects how data is arranged on the disk. It is recommended to leave this value at the default [Optimal], which is 32KB, but the values can be between [4 KB] and [128 KB].

- **Assigning the Disks**

The disks that you enabled from the RAID Config BIOS setup page appear in the **Free Disks** block. These are the drives that are available for use as RAID array disks. To designate a free disk to be used as a RAID array disk,

1. Tab to the **Free Disks** section. The first disk in the list is selected.
2. Move it from the Free Disks block to the Array Disks block by pressing the right arrow key (-->). The first disk in the list is moved, and the next disk in the list is selected and ready to be moved.
3. Continue pressing the right-arrow key (<--) until all the disks that you want to use as RAID array disks appear in the **Array Disks** block.

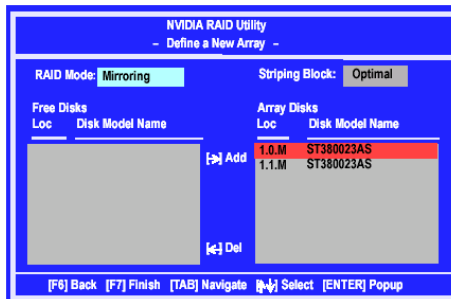

It shows that two disks have been assigned as RAID1 array disks in the figure above.

Completing the RAID BIOS Setup

1. After assigning your RAID array disks, press **F7**. The Clear disk data prompt appears.

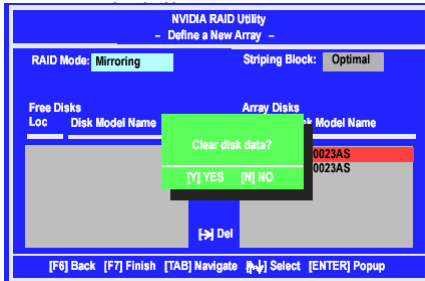

2. Press **Y** if you want to wipe out all the data from the RAID array, otherwise press **N**. You must choose **Yes** if the drives were previously used as RAID drives. The **Array List** window appears, where you can review the RAID arrays that you have set up.

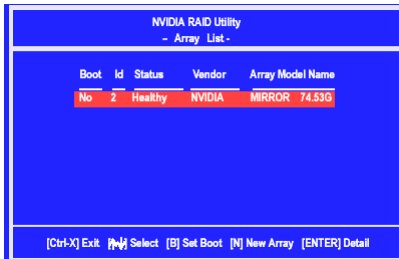

3. Use the arrow keys to select the array that you want to set up, then press **Enter**. The **Array Detail** window appears.

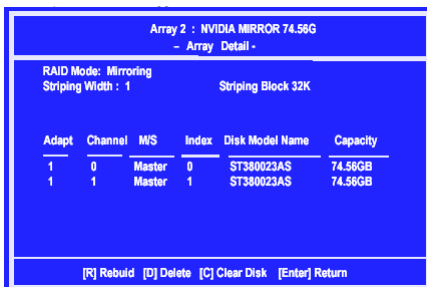

4. If you want to mark this disk as empty and wipe out all its contents then press **C**.
5. At the prompt, press **Y** to wipe out all the data, otherwise press **N**.
6. Press **Enter** again to go back to the previous window and then press **F10** to exit the RAID setup. Now that the RAID setup has been configured from the RAID BIOS, the next step is to configure and load NVRAID drivers under Windows, as explained in "Installing the NVIDIA RAID Software Under Windows" on p5-7.

NVIDIA RAID Utility Installation

Installing the NVIDIA RAID Software Under Windows (for Non-bootable RAID Array)

The existing Windows IDE Parallel ATA driver (as well as the Serial ATA driver if SATA is enabled) must be upgraded to use the NVIDIA IDE Parallel ATA driver (as well as the NV Serial ATA driver if SATA is enabled).

This section describes how to run the setup application and install the RAID software which will upgrade the Windows IDE driver and install the RAID software.

1. Start the nForce Setup program to open the NVIDIA Windows nForce Drivers page.

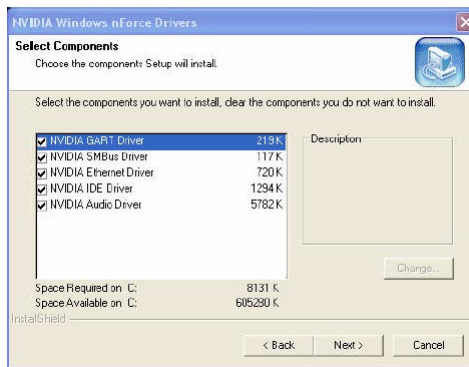

2. Select the modules that you want to install. Make sure that the “NVIDIA IDE Driver” is selected.
3. Click **Next** and then follow the instructions.
4. After the installation is completed, be sure to reboot the PC.
5. After the reboot, initialize the newly created array. See “Initializing and Using the Disk Array” on p5-10.

Installing the RAID Driver (for bootable RAID Array)

1. After you complete the RAID BIOS setup, boot from the Windows CD, and the Windows Setup program starts.
2. Press **F6** and wait for the Windows Setup screen to appear.

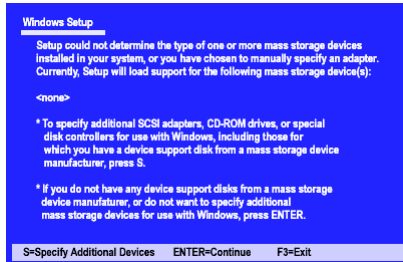

3. Specify the NVIDIA drivers:
 - (1) Insert the floppy that has the RAID driver, press S, then press Enter. The Windows Setup screen appears as below:

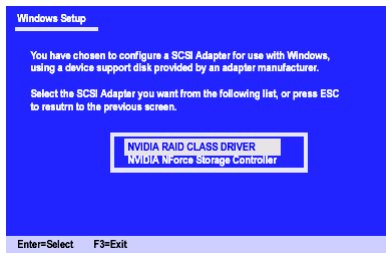

MSI Reminds You...

Please follow the instruction below to make an nVIDIA Serial ATA RAID driver for yourself.

1. *Insert the MSI CD into the CD-ROM drive.*
2. *Ignore the Setup screen and use "Explorer" to browse the CD.*
3. *Copy all the contents (including the sub-folders) in the \\nVidia\System\MCP2S\Win2k-XP\IDE\WinXP to a formatted floppy disk.*
4. *The driver disk for nVIDIA Serial ATA driver is done.*

- (2) Select "NVIDIA RAID CLASS DRIVER" and then press **Enter**.
- (3) Press **S** again at the Specify Devices screen, then press **Enter**.
- (4) Select "NVIDIA NForce Storage Controller" and then press **Enter**. The following Windows Setup screen appears listing both drivers:

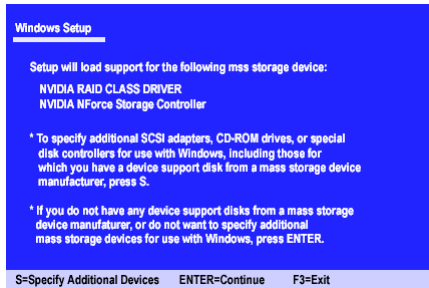

4. Press **Enter** to continue with Windows XP Installation. Be sure to leave the floppy disk inserted in the floppy drive until the blue screen portion of Windows XP installation is completed, then take out the floppy.
5. Follow the instructions on how to install Windows XP. During the GUI portion of the install you might be prompted to click **Yes** to install the RAID driver. Click **Yes** as many times as needed in order to finish the installation. This will not be an issue with a signed driver.



MSI Reminds You...

Each time you add a new hard drive to a RAID array, the RAID driver will have to be installed under Windows once for that hard drive. After that, the driver will not have to be installed

Initializing and Using the Disk Array

The RAID array is now ready to be initialized under Windows.

1. Launch Computer Management by clicking “Start” --> “Settings” --> “Control Panel” then open the “Administrative Tools” folder and double click on “Computer Management”.
2. Click “Disk Management” (under the “Storage” section). The Initialize and Convert Disk Wizards appears.



3. Click **Next**. The Select Disks to Initialize window appears. The disks listed depend on how many arrays you have configured.

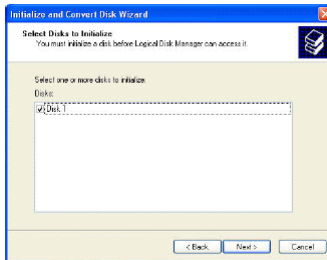

4. Click **Next**. The Select Disks to Convert window appears.

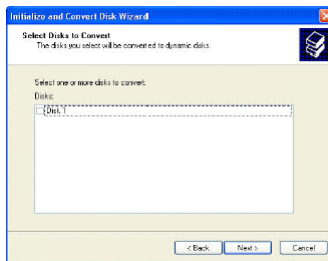

5. Check the disk in the list if you want to make the array a dynamic disk, then click **Next**. The Completing the Initialize and Convert Disk Wizard window appears.

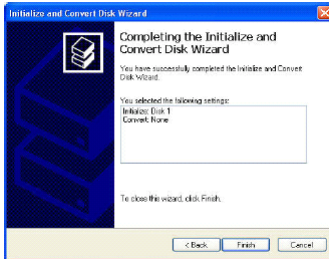

6. Click **Finish**. The “Computer Management” window appears.

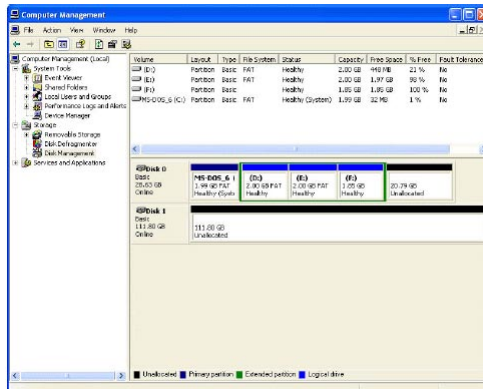

The actual disks listed will depend on your system, and the unallocated partition is the total combined storage of two hard disks. You must format the unallocated disk space in order to use it.

7. Format the unallocated disk space. Right click “Unallocated space”, select “New Partition...” and follow the wizard. After the drive has been formatted, it is ready for use.

RAID Drives Management

There is an application called NVRAIDMAN which helps you perform the following tasks of nVIDIA RAID.

- **Viewing RAID Array Configurations**
View an array configuration (mirrored, striped, mirror-striped, JBOD, or any supported combination)
- **Setting Up a Spare RAID Disk**
 - View free and/or dedicated free disks
 - Designate a free disk to a particular array
- **Rebuilding a RAID Mirrored Array**
 - Rebuild a broken mirrored array
 - Watch the progress of rebuilding an array

Viewing RAID Array Configurations

To view your RAID configuration from Windows, launch the NVRAID Management utility by double-clicking `NvRaidMan.exe` (the default location of `NvRaidMan.exe` is in `\\nVidia\System\MCP2S\Win2k-XP\IDE\WinXP` of the setup CD accompanied with your mainboard).

The RAID configuration information appears in the right-side pane, as shown below.

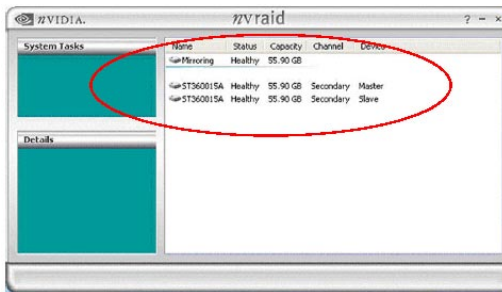

MSI Reminds You...

The information in the figures in this part may vary from what it is shown in your system.

NVRAID Mirrored Array

The figure below shows an example of a two hard drive mirrored array using identical 55.90 GB IDE hard drives (ST360015A), where one drive is configured as Master and the other drive is configured as Slave. The total hard disk space used is 55.90 GB. (1.1 GB = 1,073,741,824 bytes)

Name	Status	Capacity	Channel	Device
Mirroring	Healthy	55.90 GB		
ST360015A	Healthy	55.90 GB	Secondary	Master
ST360015A	Healthy	55.90 GB	Secondary	Slave

NVRAID Striped Array

The figure below shows an example of a two hard drive striped array using identical 55.90 GB IDE hard drives (ST360015A), where one drive is configured as Master and the other drive is configured as Slave. The total disk space used is 111.80 GB.

Name	Status	Capacity	Channel	Device
Striping	Healthy	111.80 GB		
ST360015A	Healthy	55.90 GB	Secondary	Master
ST360015A	Healthy	55.90 GB	Secondary	Slave

NVRAID Striped Mirror Array

The figure below shows an example of a four hard drive stripe-mirrored array. The total disk space used is 111.80 GB.

Name	Status	Capacity	Channel	Device
Stripe Mirroring	Healthy	111.80 GB		
ST360015A	Healthy	55.90 GB	Secondary	Master
ST360015A	Healthy	55.90 GB	Secondary	Slave
ST380023AS	Healthy	74.53 GB	Primary	Master
ST380023AS	Healthy	74.53 GB	Secondary	Master

NVRAID Spanning (JBOD) Array

The figure below shows an example of a two hard drive spanning array. The total disk space used is 111.80 GB.

Name	Status	Capacity	Channel	Device
Spanning	Healthy	111.80 GB		
ST360015A	Healthy	55.90 GB	Secondary	Master
ST360015A	Healthy	55.90 GB	Secondary	Slave

NVRAID Mirrored Array and a Striped Array

Figure 3.6 shows an example of a two hard drive mirrored array as well as a two hard drive striped array.

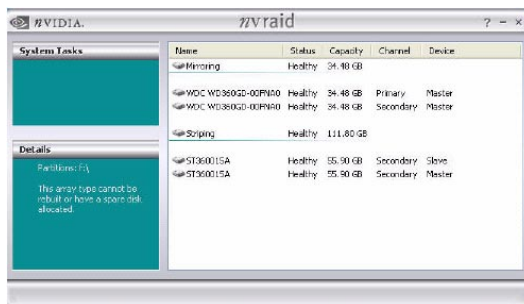

Setting Up a Spare RAID Disk

You can designate a hard drive to be used as a spare drive for a RAID 1 or RAID 0+1 array². The spare drive can take over for a failed disk. NVRAID supports two types of spare drives:

- **Free Disk**

A free disk is a disk that is not part of any RAID array, but can be used by any available RAID 1 or RAID 0+1 array that requires a particular disk when one of its disks crashes or becomes unusable. The process is automatic and doesn't require any user interaction.

For example, if you have a system with four hard disks where one disk is used to boot the OS, two hard drives are set up in a mirrored array, and a fourth hard disk is set up as a free disk, then if one of the mirrored array drives fails, the free disk will be automatically assigned to the mirrored array to be used instead of the failed disk.

- **Dedicated Disk**

A dedicated free disk is a disk that is assigned to a RAID 1 or RAID 0+1 array and that disk is used by that array only when needed, for example during a system crash where a RAID mirrored drive is broken. The dedicated disk can be used only by the array that it is assigned to and not by any other array, unlike a free disk which can be used by any available RAID 1 or RAID 0+1 array.

Assigning a Free Disk

To mark a disk as free, or not a part of any array,

1. Enter the system BIOS setup and make sure that the drive that you want to mark as free is RAID enabled.
2. Enter the RAID BIOS and make sure that the drive is not part of any array (if one exists).
3. Boot into Windows and run the NVRAIDMAN program. The drive appears under the Free Disk section. The figure below shows an example of the NVRAIDMAN display if you have a mirror array and one free disk.

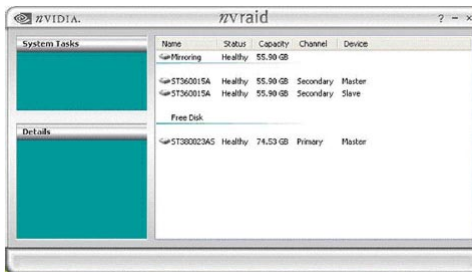

Assigning a Dedicated Disk

To mark a disk as dedicated, or reserve it for use by a specific array,

Step 1: Mark the Disk as a Free Disk

1. Enter the system BIOS setup and make sure that the drive that you want to mark as free is RAID enabled.
2. Enter the RAID BIOS and make sure that the drive is not part of any array (if one exists).
3. Boot into Windows and run the NVRAIDMAN program. The drive appears under the Free Disk section.

Step 2: Dedicate the Free Disk to an Array

While running NVRAIDMAN, dedicate the free disk to an array using one of the following two methods:

- Method 1: Select a free disk and then assign it to an array.
- Method 2: Select an array and then assign a free disk to it.

Both methods are equally simple ways of accomplishing the same task.

Method 1: Select a free disk and then assign it to an array.

1. Right click one of the available disks under the Free Disk section. The pop-up menu appears.

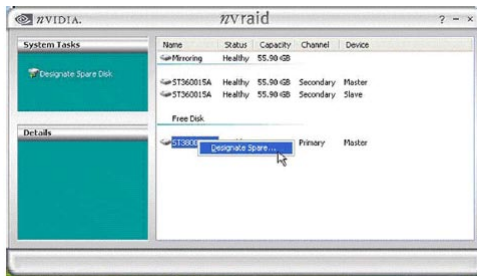

2. Select **Designate Spare** from the menu to launch the Spare Disk Allocation Wizard.



3. Click **Next**.

The RAID Array Selection page appears.

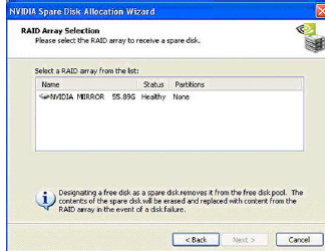

4. From the RAID Array Selection page, select one of the arrays from the list. This is the array to which you want to allocate the dedicated free disk.

Note: In Figure 3.10 there is only one array created on the system.

5. Click **Next**.

The Completing the NVIDIA Spare Disk Allocation page appears.



6. Click **Finish**.

As shown in figure below, the ST380023AS drive is now a dedicated free disk in the mirrored array. If a system crash occurs that causes any of the two ST360015A drives to fail, the ST380023AS hard drive will take over and be used in the newly formed mirrored array.



Once a dedicated disk has been assigned to a particular array, it can be removed at any time. To remove the disk, right click on the dedicated disk and select the option to remove it.

Method 2: Select an array and then assign a free disk to it.

1. Right click on the array to which you want to assign a dedicated free disk. The pop-up menu appears.



2. Select **Designate Spare** from the menu to launch the Spare Disk Allocation Wizard.



3. Click **Next**. The Free Disk Selection page appears.

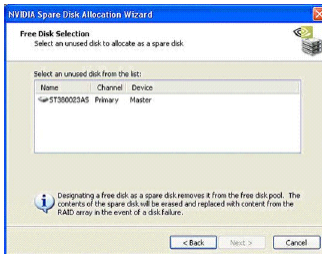

4. From the Free Disk Selection page, select one of the disks from the list. Please note that there can be more than one disk to choose from.

5. Click **Next**. The Completing the NVIDIA Spare Disk Allocation page appears.



6. Click **Finish**. You have now assigned a dedicated free disk to a mirrored array.

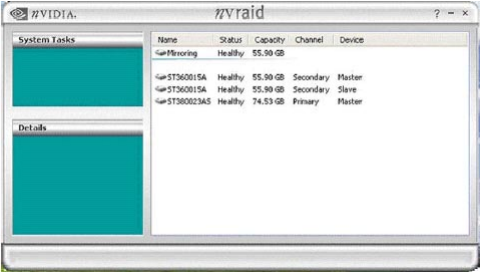

Once a dedicated disk has been assigned to a particular array, it can be removed at any time. To remove the disk, right click on the dedicated disk and select the option to remove it.

Example of Dedicating a Free Disk in a RAID 1 or RAID 0+1 Array

You can also assign a dedicated free disk to a RAID 1 or a RAID 0+1 array, using the same process.

1. Right-click either the free disk that you want to dedicate to an array, the array type, or the array drives as shown in the figure below. Then click Designate Spare to launch the Spare Disk Allocation Wizard.

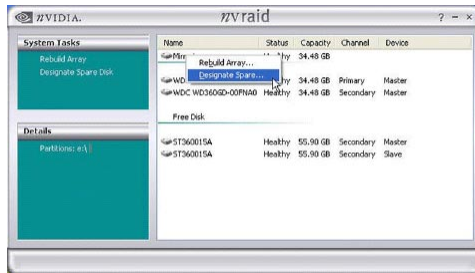

2. Click **Designate Spare** and then follow the instructions in the Wizard. The figure below shows an example of a RAID 1 array that has one spare disk dedicated to it.

Once a dedicated disk has been assigned to a particular array, it can be removed at any time. To remove the disk, right click on the dedicated disk and select the option to remove it.

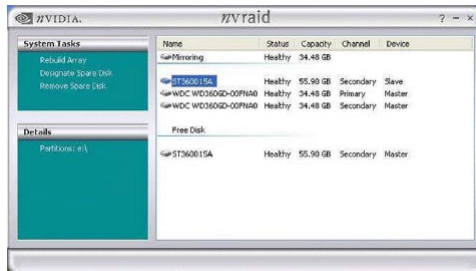

4. Click **Next**. The Disk Selection page appears.

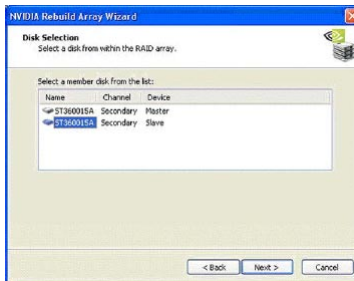

5. Select the drive that you want to rebuild by clicking it from the list, then click **Next**. The Completing the NVIDIA Rebuild Array page appears.



6. Click **Finish**. The array rebuilding starts after a few seconds, and a small pop-up message appears towards the bottom right corner of the screen as shown in the figure below.

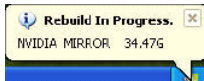

During the rebuilding process, the NVRAID Management utility screen shows the status under the System Tasks and Details sections.

More About Rebuilding Arrays

• Rebuilding Occurs in the Background

The rebuilding process is very slow (it can take up to a day) and occurs in the background so as not to affect the performance of the system.

• Rebuilding Applies Only to RAID 1 or RAID 0+1 Arrays

Rebuilding an array works only when using RAID1 and/or RAID 0+1. Rebuilding does not apply to RAID 0 and JBOD arrays.

• You Can Use Any Available Free Disk

You can rebuild a mirrored array using any available Free Disk or Dedicated Disk.

For example, the figure below shows a mirrored array using 34.48 GB HD while having two Free Disks each 55.90 GB large.

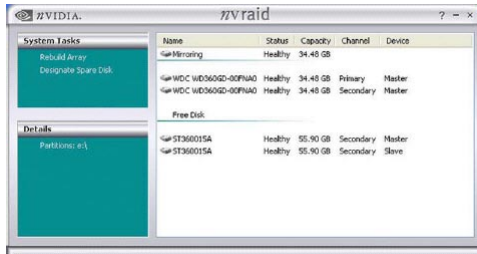

To use one of these available free disks to rebuild your array, follow the same steps as explained in "Rebuilding a RAID Mirrored Array" on p.5-20, except when prompted to select a disk, choose one of the two available free disks.