

DPI533 Series Motherboard

User's Manual

FCC Guidelines

This equipment has been tested and found to comply with the limits for a Class B digital device, pursuant to Part 15 of the FCC rules. These limits are designed to provide reasonable protection against harmful interference in a residential installation. This equipment generates, uses and can radiate radio frequency energy and, if not installed and used in accordance with the instructions may cause harmful interference to radio communications. However, there is no guarantee that interference will not occur in a particular installation. If this equipment does cause harmful interference to radio or television reception, which can be determined by turning the equipment off and on, the user is encouraged to try to correct the interference by one or more of the following measures:

- Reorient or relocate the receiving antenna.
- Increase the separation between the equipment and the receiver.
- Connect the equipment into an outlet on a circuit different from that to which the receiver is connected.
- Consult the dealer or an experienced radio TV technician for help.
- Use only shielded cables to connect I/O devices to this equipment.

This device complies with Part 15 of the FCC Rules. Operation is subject to the following two conditions: (1) This device may not cause harmful interference. (2) This device must accept any interference received, including interference that may cause undesired operation.

Information to User:

Any changes or modifications not expressly approved by the party responsible for compliance could void the user's authority to operate this equipment. Shielded interference cable, if any, must be used in order to comply with emission limits.

Disclaimer of Warranties

The information in this document is subject to change without notice. The manufacturer makes no representatives or warranties with respect to the contents hereof and specifically disclaims any implied warranties of merchantability or fitness for any particular purpose. Furthermore, the manufacturer reserves the right to revise this publication and to make changes from time to time in the content hereof without obligation of the manufacturer to notify any person of such revision or changes.

Copyright

This publication, including all photographs, illustrations and software, is protected under international copyright laws, with all rights reserved. Neither this manual, nor any of the material contained herein, may be reproduced without the express written consent of the copyright holders.

© 2003. All rights reserved.

Trademark Recognition

Microsoft and Windows are registered trademarks of Microsoft Corp. Other product names used in this manual are the properties of their respective owners and are acknowledged.

Table of Contents

Static Electricity Precautions.....	4
Package Contents.....	5
Before Using the Motherboard.....	5
Handling the Motherboard.....	6
Tips in Handling the Motherboard.....	6
Quick Installation Guide.....	7
Chapter 1 - Components and Features.....	8
Chapter 2 - Hardware Installation.....	47
Chapter 3 - BIOS.....	66
Chapter 4 - Drivers and Utilities.....	85
Chapter 5 - Technical Specifications.....	91
Chapter 6 - Performance Optimization.....	97
Chapter 7 - Troubleshooting.....	99

Static Electricity Precautions

It is quite easy to inadvertently damage your PC, mainboard, components or devices even before installing them in your system unit. Static electrical discharge can damage computer components without causing any signs of physical damage. You must take extra care in handling them to ensure against electrostatic build-up.

1. To prevent electrostatic build-up, leave the device in its anti-static bag until you are ready to install it.
2. Wear an antistatic wrist strap.
3. Do all preparation work on a static-free surface.
4. Hold the device only by its edges. Be careful not to touch any of the components, contacts or connections.
5. Avoid touching the pins or contacts on all modules and connectors. Hold modules or connectors by their ends.



Electrostatic discharge (ESD) can damage your processor, disk drive and other components. Perform the upgrade instruction procedures described at an ESD workstation only. If such a station is not available, you can provide some ESD protection by wearing an antistatic wrist strap and attaching it to a metal part of the system chassis. If a wrist strap is unavailable, establish and maintain contact with the system chassis throughout any procedures requiring ESD protection.

Package Contents

The motherboard package includes the following items:

- DPI533 Series motherboard
- ATA-66/100 IDE cable
- Serial ATA cable + SATA power cable
- Floppy disk drive cable
- Rear panel I/O shield
- Two CPU back plates
- Two heat sink retention modules
- 3 jumper caps (Extra caps in case original caps get lost.)
- CD (contains drivers and utilities)
- User's manual

If any of these items are missing or damaged, please contact your dealer or sales representative for assistance.



Before you proceed, please read the “EPS 12V Power Connectors” section in this chapter. This section contains information about the type of power supply that you must use with this motherboard.

Before Using the Motherboard...

Before you install and use the motherboard, please check the following:

- Package contents

Make sure the package contains all items listed above. If any of these items are missing, please contact your dealer or sales representative for assistance.

- Damaged accessories

If any of the items are damaged, please contact your dealer or sales representative for assistance.

- Motherboard damage

If the motherboard has been visibly damaged, return the complete package to your dealer with the proof of purchase.

- Prepare basic system components

If you are installing the motherboard in a new system, you will need at least the following internal components.

- An Intel® Xeon™ CPU
- At least two DDR SDRAM memory module
- Storage devices such as hard disk drive, CD-ROM, etc.

You will also need whatever external system peripherals you intend to use which will normally include at least a keyboard, a pointing device and a video display monitor.

Handling the Motherboard

It is quite easy to inadvertently damage the motherboard even before installing it in your system unit. Electrostatic discharge can damage computer components without causing any signs of physical damage. You must take extra care in handling the motherboard to ensure that no static build-up is present.

Tips in Handling the Motherboard

1. To prevent electrostatic build-up, leave the motherboard in its anti-static bag until you are ready to install it.
2. Do all preparation work on a static-free surface with motherboard components facing up.
3. Hold the motherboard by its edges only. Be careful not to touch any of the components, contacts or connections, especially gold contacts, on the board.

Quick Installation Guide

Step 1

Install the CPU, CPU fan / heatsink and other system fans.

Step 2

Install the DIMM.

Step 3

Install add-in cards.

Step 4

Configure the jumpers.

Step 5

Connect the floppy disk drive cable and IDE disk drive cable to their respective devices.

Step 6

Connect the power supply's cables to the appropriate connectors and devices.

Step 7

Connect devices to the ports located at the rear panel.

Step 8

Connect the front panel cables (LED indicators and switch connectors) to the front panel connectors.

Step 9

Power on the PC.

Step 10

Configure the BIOS.

Step 11

Reboot the PC.

Step 12

Install the drivers and utilities that are in the provided CD.

Chapter 1

Components and Features

Components and Features

1.1 Motherboard Layout

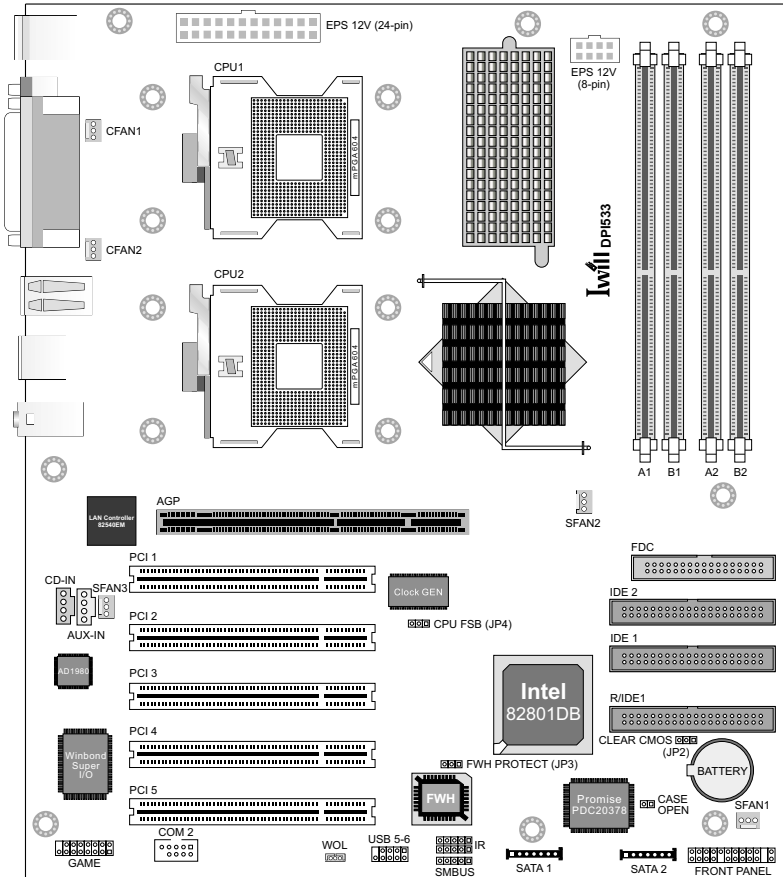

User's Manual

1.1.1 Components

Descriptions	Locations
mPGA604 CPU sockets	CPU1 and CPU2
Channel A DIMM slots	A1 (J4) and A2 (J6)
Channel B DIMM slots	B1 (J5) and B2 (J7)
AGP	J23
PCI 1 to PCI 5	J25, J30, J32, J34 and J36
EPS 12V (24-pin)	J1
EPS 12V (8-pin)	J3
CPU Fan 1	CFAN1 (J22)
CPU Fan 2	CFAN2 (J9)
System Fan 1	SFAN1 (J38)
System Fan 2	SFAN2 (J14)
System Fan 3	SFAN3 (J27)
CD-IN	J29
AUX-IN	J28
GAME	J42
COM 2	J41
WOL (Wake-On-LAN)	J47
USB 5-6	J43
IR	J39 and J40
SMBUS	J48
SATA 1	J46
SATA 2	J45
FRONT PANEL	J44
CPU FSB	JP4
FWH PROTECT	JP3
CLEAR CMOS	JP2
CASE OPEN	J37
FDC	J24
IDE 1	J31
IDE 2	J26
R/IDE1	J33

1.2 Chipset

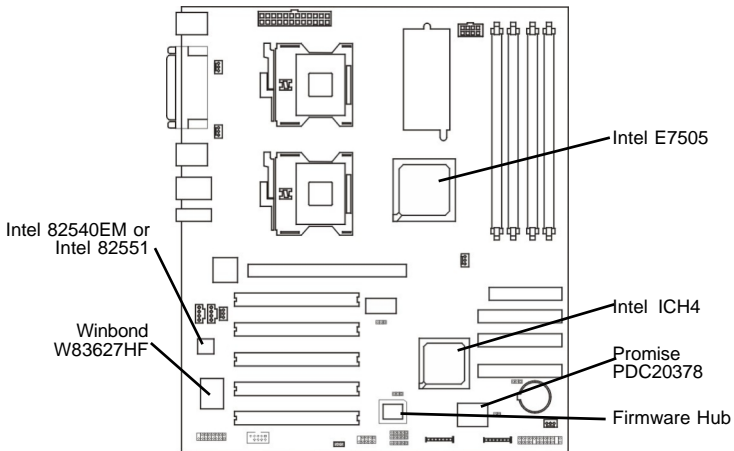

Intel Chipset

The Intel E7505 chipset supports dual-processor workstation platforms optimized for the Intel® Xeon™ processor with 533MHz system bus. The components of the chipset include the following mounted on the board:

- North bridge: Intel E7505 Memory Controller Hub (MCH) - 133MHz FSB
- South bridge: 82801DB I/O Controller Hub (ICH4) - 266MB/s

The Intel E7505 chipset also provides host bus, memory, AGP and I/O interfaces.

Intel LAN Controller

- Intel Kenai 32 82540EM Gigabit ethernet LAN controller (DPI533 and DPI533-SATA only)
 - High-speed 1Gigabit/sec data transfer
 - Supports 10-BaseT and 100Base-TX
 - Supports Wake-On-LAN
- Intel 82551QM 10/100 LAN interface (DPI533-L only)

User's Manual

Promise Serial ATA and RAID Controller (DPI533-SATA Only)

The Promise PDC20378 controller supports:

- 2 serial ATA ports and 1 RAID IDE connector that support RAID level 0, 1 and 0+1

Super I/O Controller

The Winbond W83627HF supports hardware monitor.

1.3 CPU Socket

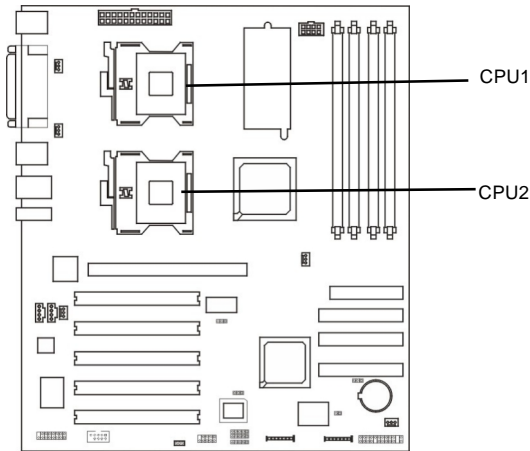

Function

The two mPGA604 sockets are for installing Intel® Xeon™ processors at 400/533MHz.

- System bus: 100/133MHz
- Supports Prestonia and Nocona533 processors
- Auto detect CPU type for external clock and multiplier settings
- Third party fixer to fix Xeon heat sink.

CPU Power

- Compliant to VRM 9.1 specification
- VRD design

Installation Notes

- You can install either one or two CPUs.
- When installing one CPU, install it in the CPU1 socket.
- When installing two CPUs, make sure to use identical CPUs. The CPU settings (clock speed and ratio) must also be identical.

User's Manual

CPU Installation

Refer to chapter 2 for information on the CPU installation procedure.

BIOS Settings

The BIOS automatically detects the CPU clock. You can manually configure the settings in the IwILL Smart Setting submenu of the BIOS. Refer to chapter 3 for more information.

1.4 System Memory

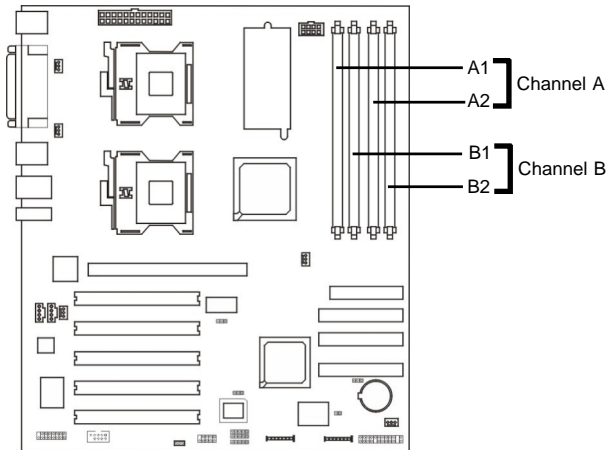

Function

The DIMM sockets are for installing DDR SDRAM memory modules. DDR SDRAM (Double Data Rate SDRAM) is a type of SDRAM that doubles the data rate through reading and writing at both the rising and falling edge of each clock. This effectively doubles the speed of operation therefore doubling the speed of data transfer. The sockets function independently allowing a variety of memory configurations.

- Four DDR DIMM sockets
 - Supports dual channel memory interface
 - Each channel supports 2 DIMM sockets
- PC1600 (DDR200) or PC2100 (DDR266) DDR SDRAM modules
- Supports ECC memory
- Supports unbuffered DIMMs
- Supports maximum of 8GB memory using 64,128, 256, 512Mbit or 1Gbit technology
- Peak memory bandwidth: 4.2GB/s

User's Manual

Memory Configuration

- Supports 128MB, 256MB, 512MB, 1GB and 2GB modules.
- Modules must all be the same type and capacity.
- Install only 2 or 4 DIMMs; DO NOT install 1 DIMM or 3 DIMMs.

The four DDR DIMM sockets are divided into 2 channels:

Channel A - DIMM A1 (J4) and DIMM A2 (J6)

Channel B - DIMM B1 (J5) and DIMM B2 (J7)

The figures below illustrate the ONLY allowed module configurations. Do not install modules in any other configuration.

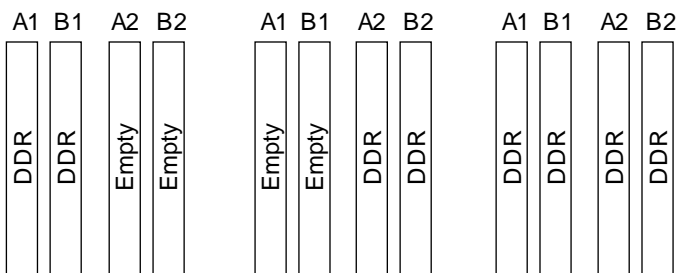

Memory Installation

Refer to chapter 2 for information on the memory installation procedure.

BIOS Settings

You can configure the system memory in the Advanced Chipset Features submenu of the BIOS. Refer to chapter 3 for more information.

1.5 Expansion Slots

1.5.1 AGP Slot

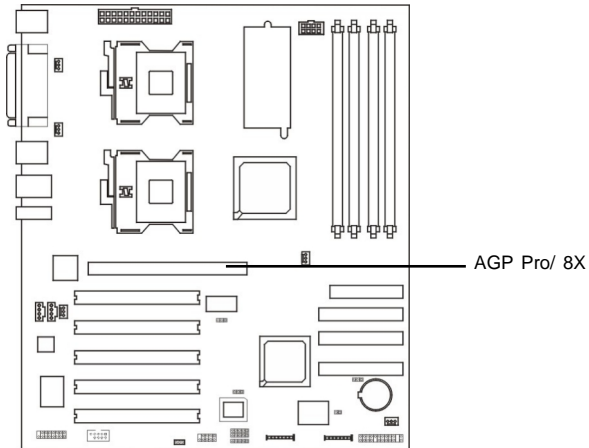

Function

The AGP slot is for installing an AGP interface video display card. AGP is an interface designed to support high performance 3D graphics cards for 3D graphics applications. It is AGP 3.0 compliant. The slot supports three types of AGP card.

- AGP 8x (2.13GB/sec bandwidth)
- AGP 4x (1066MB/sec. bandwidth)
- AGP Pro 50 (The slot is extended to support AGP Pro cards that use up to 50 watts of power)



The slot only supports 1.5V devices. Do not install 3.3V AGP card.

BIOS Settings

Configure the amount of system memory the AGP card will use as auxiliary memory by selecting the AGP Aperture Size in the Advanced Chipset Features submenu of the BIOS. Refer to chapter 3 for more information.

Display Drivers

If the AGP card comes with a display driver, you must install the driver according to the documentation that came with it.

User's Manual

1.5.2 PCI Slots

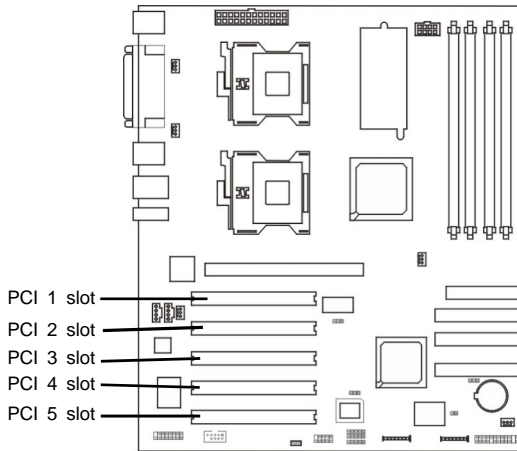

Function

The five PCI slots are for installing PCI expansion cards. These slots are Bus Master capable, 32-bit, 33MHz and PCI 2.2 compliant. The slots provide a fast high-bandwidth pathway between the motherboard and expansion cards.

BIOS Settings

The BIOS automatically configures Plug and Play and other PCI bus settings. Basically, you do not need to change any resource settings unless you encounter a problem after installing an expansion card. You can reconfigure the settings in the PnP/PCI Configurations submenu of the BIOS. Refer to chapter 3 for more information.

1.6 Rear Panel I/O Ports

1.6.1 PS/2 Keyboard and PS/2 Mouse Ports

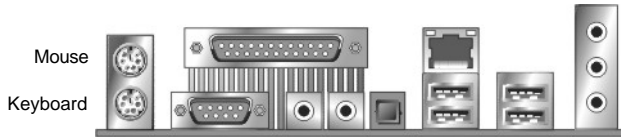

Function

The PS/2 mouse (Green) and PS/2 keyboard (Purple) ports are for connecting a PS/2 mouse and PS/2 keyboard respectively. The PS/2 mouse port uses IRQ12. If a mouse is not connected to this port, the system will reserve IRQ12 for other expansion cards.

 Make sure to turn off your computer prior to connecting or disconnecting a mouse or keyboard. Failure to do so may damage the motherboard.

Keyboard/Mouse Power Up Function

You can configure the system to use the keyboard or mouse to power-on the system. To use this function: "Power On Function" ("Super IO Device" field) in the Integrated Peripherals submenu of the BIOS must be set accordingly. Refer to chapter 3 for more information.

User's Manual

1.6.2 Parallel Port

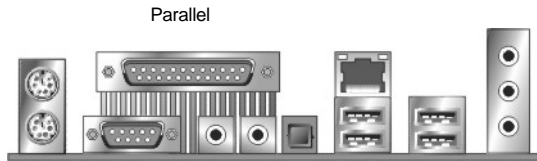

Function

The standard parallel port (Burgundy) is for interfacing your PC to a parallel printer. It supports SPP, ECP and EPP modes.

- SPP (Standard Parallel Port)
Allows normal speed operation but in one direction only.
- ECP (Extended Capabilities Port)
Allows parallel port to operate in bidirectional mode and at a speed faster than the SPP's data transfer rate.
- EPP (Enhanced Parallel Port)
Allows bidirectional parallel port operation at maximum speed.

BIOS Setting

Select the parallel port's mode in the Integrated Peripherals submenu ("Super IO Device" field) of the BIOS. Refer to chapter 3 for more information.

Components and Features

1.6.3 Serial Ports

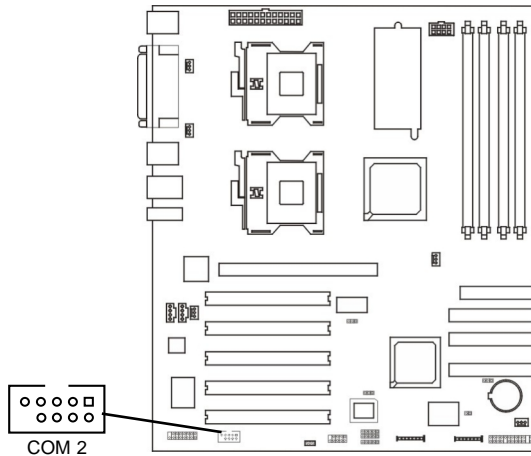
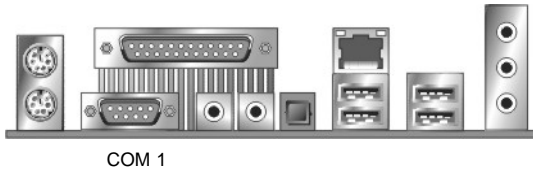

Function

The serial ports are RS-232C asynchronous communication ports with 16C550A-compatible UARTs that can be used with modems, serial printers, remote display terminals, and other serial devices. It can operate at speeds up to 115,200bps. You can configure the port's speed in the computer's Operating System.

The motherboard is equipped with an onboard serial port (Teal/Turquoise) for COM 1 and a 9-pin connector at location J41 for COM 2.

BIOS Setting

Select the serial ports' I/O address in the Integrated Peripherals submenu ("Super IO Device" field) of the BIOS. Refer to chapter 3 for more information.

User's Manual

1.6.4 Rear Out and Center Out Jacks

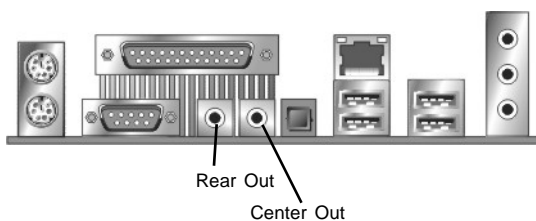

Function

The rear out (black) and center out (orange) jacks support four audio output signals. The rear out jack supports rear right channel and rear left channel. The center out jack supports center channel and subwoofer. These four audio output signals together with the line-in and mic-in jacks support 6-channel audio output.

1.6.5 S/PDIF-Out Jack

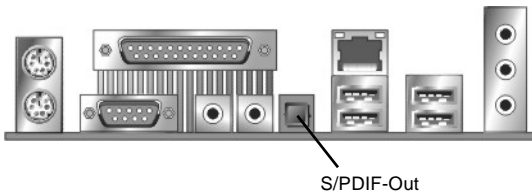

Function

S/PDIF is a standard audio file transfer format that transfers digital audio signals to a device without having to be converted first to an analog format. This prevents the quality of the audio signal from degrading whenever it is converted to analog.

The S/PDIF connector is used to connect the onboard AC'97 audio subsystem to external 5.1 audio devices. The connector has a composite signal which includes the audio channels of a 5.1 speaker system. These are:

- Front left/right speakers
- Rear left/right speakers
- Center channel speaker
- Subwoofer

The S/PDIF connector must be connected to a digital decoder that splits the audio signal and directs it to the various audio channel.

User's Manual

1.6.6 LAN Port

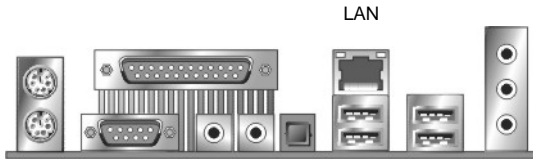

Function

The LAN port uses a CAT 5 LAN cable for connecting the motherboard to a local area network by means of a network hub. The port has 2 indicator LEDs.

Speed LED (left)

- 10Mbps - will not blink
- 100Mbps - LED is green
- 1000Mbps - LED is orange

Link and Activity LED (right)

- LED is yellow when the LAN connection is linked and accessed.

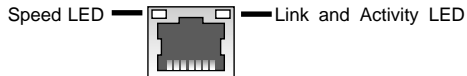

BIOS Setting

Enable or disable the onboard LAN in the Integrated Peripherals submenu of the BIOS. Refer to chapter 3 for more information.

Driver Installation

Install the "LAN Drivers" contained in the provided CD into your system. Refer to chapter 4 for more information.

Components and Features

1.6.7 USB Ports

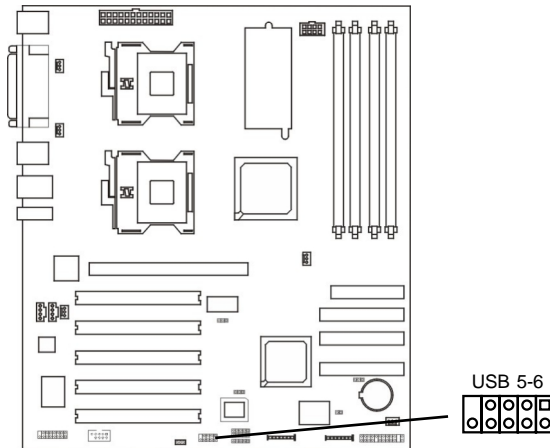
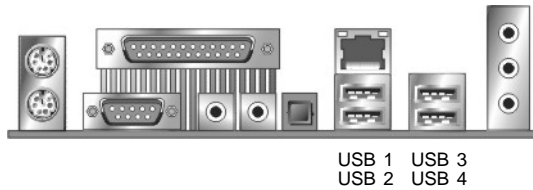

Function

The motherboard supports USB 2.0 and USB 1.1 ports. USB 1.1 supports 12Mb/second bandwidth while USB 2.0 supports 480Mb/second bandwidth providing a marked improvement in device transfer speeds between your computer and a wide range of simultaneously accessible external Plug and Play peripherals. You can connect or disconnect USB cables when the system is turned on.

The motherboard is equipped with four onboard USB ports for rear panel connection. It is also equipped with a 9-pin connector at location J43 for connecting 2 additional USB ports.

User's Manual

BIOS Setting

Enable or disable the onboard USB in the Integrated Peripherals submenu of the BIOS. Refer to chapter 3 for more information.

If you are using a USB 2.0 device, install the "USB 2.0 Drivers" contained in the provided CD. Refer to chapter 4 for more information.

Driver Installation

You may need to install the proper drivers in your operating system to use the USB device. Refer to your operating system's manual or documentation for more information.

Pin Assignment of USB 5-6

Pin	Assignment	Pin	Assignment
1	+5V	2	+5V
3	USB DATA6-	4	USB DATA5-
5	USB DATA6+	6	USB DATA5+
7	GND	8	GND
9	NC	10	NC

Components and Features

1.6.8 Audio Jacks

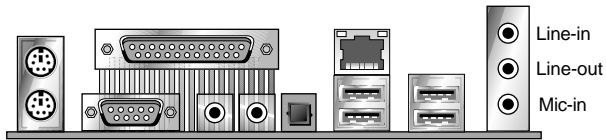

Function

- Line-in Jack (Light Blue)
This jack is an audio input connector for an external audio source.
- Line-out Jack (Lime)
This jack is used to connect stereo speakers for audio output.
- Mic-in Jack (Pink)
This jack is used to connect an external microphone.

1.7 Serial ATA Connectors and RAID Connector (DPI533-SATA only)

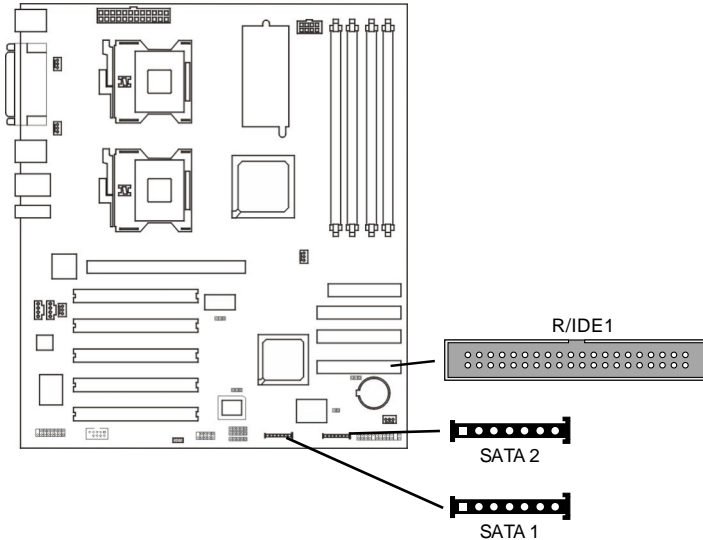

The Promise PDC20378 controller supports RAID level 0, 1 and 0+1 on devices connected to the two Serial ATA ports and the RAID IDE connector. In other words, devices connected to these interfaces can be configured as RAID.

Serial ATA is a storage interface that is compliant with SATA 1.0 specification. With speed of up to 1.5Gbps, it improves hard drive performance even in data intensive environments such as audio/video, consumer electronics and entry-level servers.

For optimal performance, install identical drives of the same model and capacity. The drives' matched performance allows the RAID array to function better as a single drive.

Drives in an array must be identical. If striping for performance, use two new drives. If mirroring for protection, you can use two new drives or use an existing drive and a new drive (the new drive must be the same size or larger than the existing drive). Only two drives can be configured as RAID. Since striping or mirroring is done on the same channel, one drive must be set in Master mode and the other in Slave mode.

Components and Features

Connecting Serial ATA Devices

Connect one end of the cable to J46 (SATA 1) or J45 (SATA 2) and the other end to your serial ATA device. Connect the serial ATA power cable.

Connecting IDE Drives

Install one end of the IDE cable into the R/IDE1 header on the motherboard and the other connectors to the IDE devices.

BIOS Setting

Configure the onboard Serial ATA and IDE in the Integrated Peripherals submenu of the BIOS. Refer to chapter 3 for more information.

Driver Installation

You must install the RAID driver contained in the provided CD. Refer to chapter 4 for more information.

User's Manual

1.9 IDE Drive Connectors

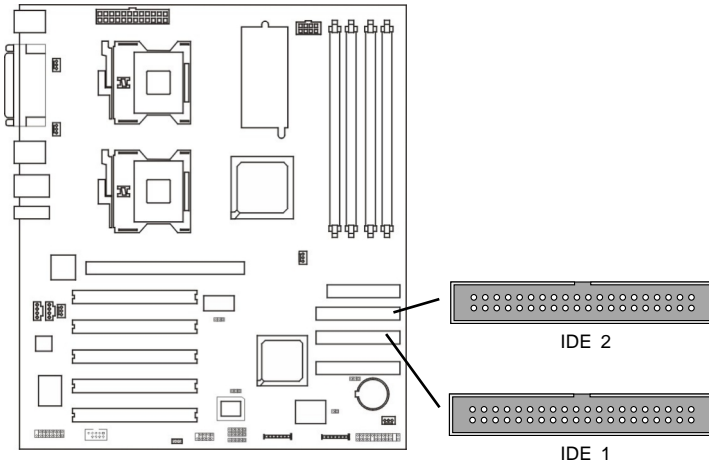

Function

The 2 IDE disk drive connectors are Primary and Secondary IDE channels for connecting up to four ATA/100 IDE devices. It supports PIO (Programmable Input/Output) and DMA (Direct Memory Access) mode operations for a maximum data transfer rate of 100Mbps per channel.

Each IDE connector supports 2 devices, a Master and a Slave. Use an IDE ribbon cable to connect the drives to the motherboard. An IDE ribbon cable has 3 connectors on them, one that plugs into a drive connector on the motherboard and the other 2 connect to IDE devices. The connector at the end of the cable is for the Master drive and the connector in the middle of the cable is for the Slave drive.

Connecting IDE Drives

Install one end of the IDE cable into the IDE 1 header on the motherboard and the other connectors to the IDE devices.

If you are adding a third or fourth IDE device, use another IDE cable and install one end of the cable into the IDE 2 header on the motherboard and the other connectors to the IDE devices.

Components and Features



Refer to your disk drive user's manual for information about selecting proper drive switch settings.

Adding a Second IDE Disk Drive

When using two IDE drives, one must be set as the master and the other as the slave. Follow the instructions provided by the drive manufacturer for setting the jumpers and/or switches on the drives.

We recommend that you use hard drives from the same manufacturer. In a few cases, drives from two different manufacturers will not function properly when used together.

BIOS Setting

Enable or disable the onboard primary or secondary IDE controller in the Integrated Peripherals submenu ("OnChip IDE Device" field) of the BIOS. Refer to chapter 3 for more information.

User's Manual

1.10 Floppy Disk Drive Connector

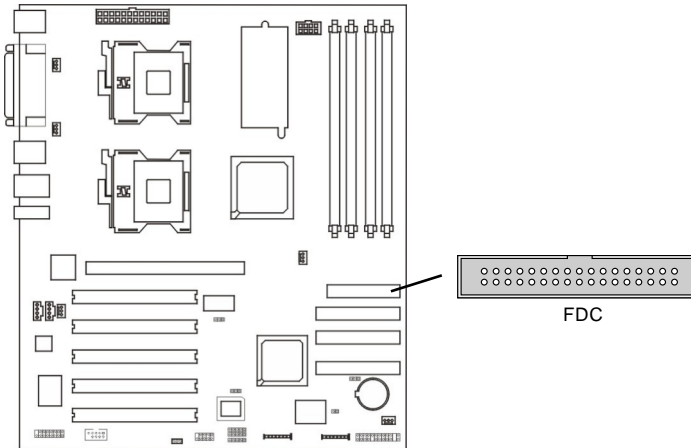

Function

The FDD connector is for connecting up to two floppy disk drives.

Connecting Floppy Drives

Install one end of the floppy disk drive cable into the floppy disk header on the motherboard and the other end-most connector to the drive you want to designate as Drive A. If you are connecting another drive (Drive B), install the middle connector of the cable to the drive.

BIOS Setting

Enable or disable this function in the Integrated Peripherals submenu ("Super I/O Device" field) of the BIOS. Refer to chapter 3 for more information.

1.11 SMBus Connector

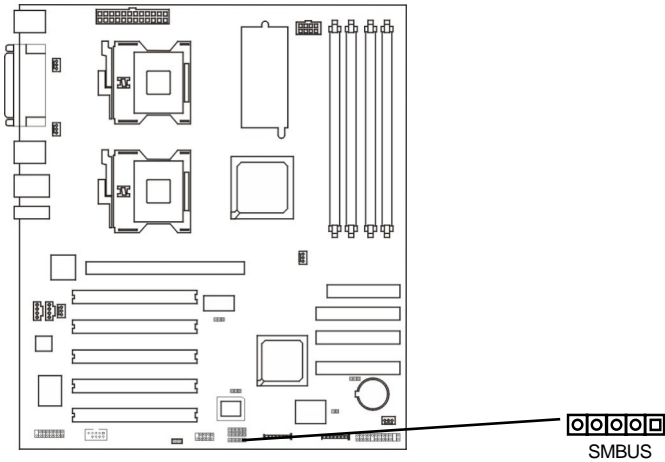

Function

The SMBus (System Management Bus) connector is used to connect SMBus devices. It is a multiple device bus that allows multiple chips to connect to the same bus and enable each one to act as a master by initiating data transfer.

1.12 IrDA Connector

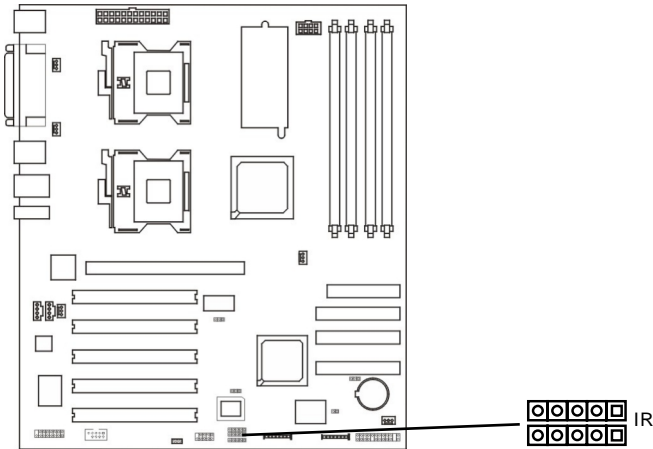

Function

The IrDA connector is for wireless connectivity between your computer and peripheral devices. The IRDA (Infrared Data Association) specification supports data transfers of 115K baud at a distance of 1 meter. It supports both IrDA and ASKIR infrared port modules.

Connecting the IrDA Cable

To use the IrDA function, follow the steps below.

1. Connect your IrDA cable to connector J39 and J40.
2. Set the "UART Mode Select" field to the type of IrDA standard supported by your IrDA peripheral/device. For better transmission of data, your IrDA peripheral device must be within a 30° angle and within a distance of 1 meter.

You may not use IrDA and the COM 2 serial port at the same time. If you are using the COM 2 serial port, make sure to set the "UART Mode Select" field to Normal.

3. Set the "RxD, TxD Active", "IR Transmission Delay", "UR2 Duplex Mode" and "Use IR Pins" fields appropriately. Refer to chapter 3 for more information.

Components and Features

Driver Installation

You may need to install the proper drivers in your operating system to use the IrDA function. Refer to your operating system's manual or documentation for more information.

User's Manual

1.13 Game/MIDI Connector

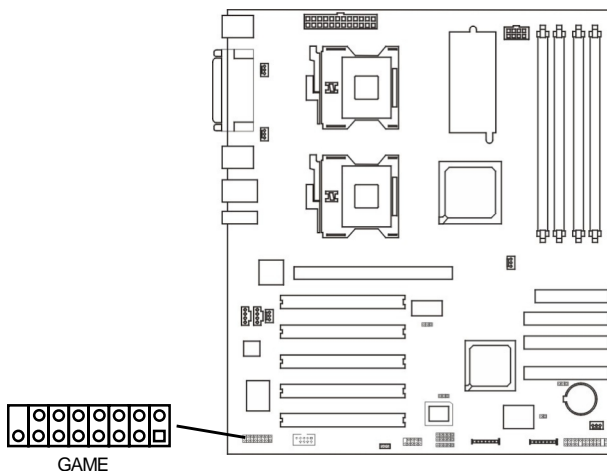

Function

The 15-pin connector is for connecting an external game/MIDI port. This game/MIDI port works well with any application that is compatible with the standard PC joystick.

Connecting the External Game/MIDI Port

Install the card-edge bracket that is mounted with a game port to the system chassis then connect the game/MIDI port cable to connector J42. Make sure the colored stripe on the ribbon cable is aligned with pin 1 of connector J42.

BIOS Setting

Configure the game port in the Integrated Peripherals submenu ("Super I/O Device" field) of the BIOS. Refer to chapter 3 for more information.

1.14 CD-in and AUX-in Connectors

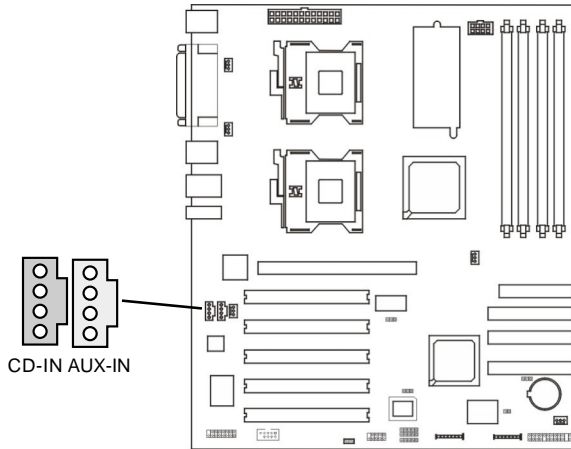

Function

The CD-in connector is used to receive audio from a CD-ROM drive, DVD-ROM drive or other optical drives. The AUX-in connector is for an additional drive or a modem/telephony device. These connectors provide an audio input connection between a device and the integrated AC'97 audio subsystem.

User's Manual

1.15 CPU Fan Connectors

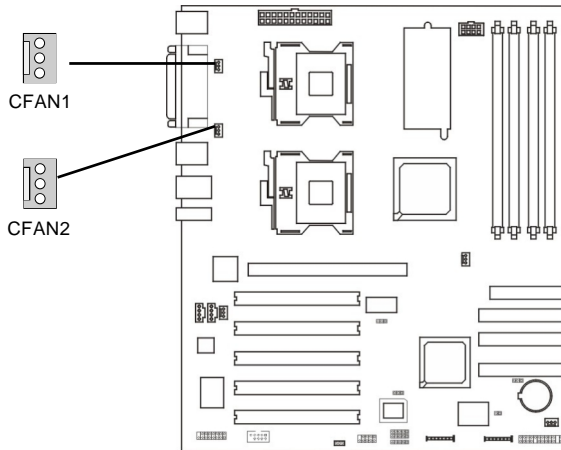

Function

The CPU fan connectors are used to connect the CPUs' cooling fans. Without sufficient air circulation across the CPU and heat sink, the CPU will overheat damaging both the CPU and motherboard. The system is capable of monitoring the speed of the CPU fan but does not control its speed.

Connecting the CPU Fans

Connect the CPU fan to the 3-pin fan connector at location CFAN1 (J22) or CFAN2 (J9) of the motherboard.

BIOS Setting

The "PC Health Status" submenu of the BIOS will display the current speed of the CPU fan. Refer to chapter 3 for more information.

1.16 System Fan Connectors

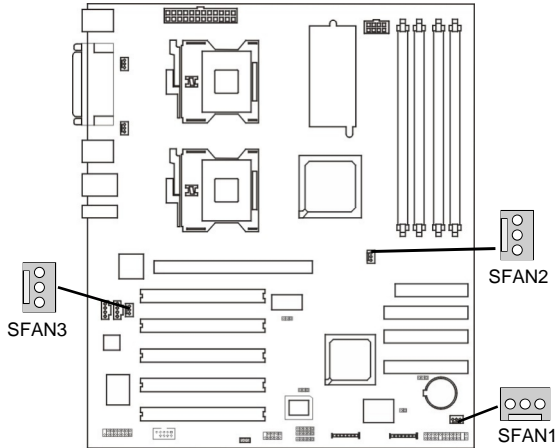

Function

SFAN1, SFAN2 and SFAN3 connectors are used to connect the system's cooling fans. The cooling fans will provide adequate airflow throughout the chassis to prevent overheating the CPU and motherboard components. The system is capable of monitoring and controlling the speed of the cooling fans. The cooling fans use the motherboard's fan speed control which may be in Normal speed or High speed.

First, the system fans will run at normal speed until the thermal sensor senses the temperature exceeded the High speed threshold temperature. The system fans will then run at High speed.

Connecting the System Fans

Connect the system fan to the 3-pin fan connector at location SFAN1 (J38), SFAN2 (J14) or SFAN3 (J27) of the motherboard.

User's Manual

1.17 Wake-On-LAN Connector

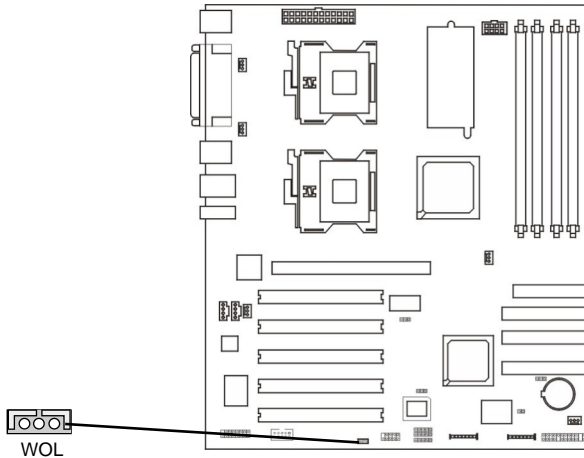

Function

The motherboard supports Wake-On-LAN through the PCI bus PME# signal and the onboard Intel ethernet controller.

The Wake-On-LAN function works with the onboard LAN port and will also work with a PCI LAN card that supports this feature. It allows the network to remotely wake up a Soft Power Down (Soft-Off) PC. However, if your system is in the Suspend mode, you can power-on the system only through an IRQ or DMA interrupt.

Connecting the Wake-On-LAN Cable

Your LAN card package should include a cable. Connect one end of the cable to the wakeup header on the card and the other end to location WOL on the motherboard. The network will detect Magic Packet and assert a wakeup signal to power-up the system. Refer to the add-in card's manual for details.

BIOS Setting

To use the Wake-On-LAN function, you must enable this function in the Power Management Setup submenu of the BIOS.

1.17 Chassis Intrusion Connector

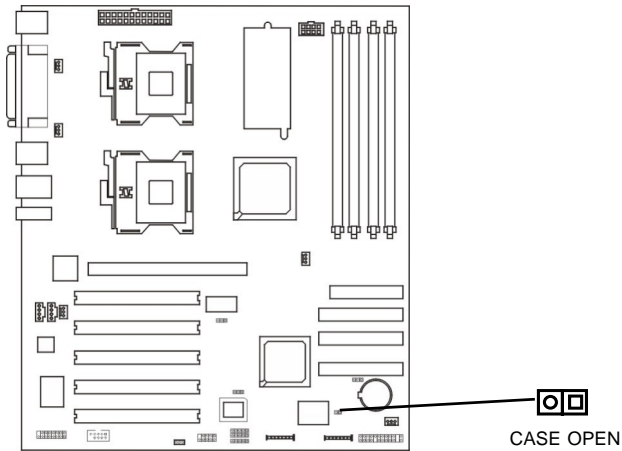

Function

The hardware monitor subsystem supports a chassis security feature that detects the chassis cover. When the cover is removed, a signal is sent to the hardware monitor component.

The chassis intrusion circuit is powered by the system's power supply when the system is connected to an AC power or by the onboard battery when it is not.

Connecting the Chassis Intrusion Sensor Cable

Connect the chassis intrusion sensor cable from the chassis to J37. To disable this function, place a jumper cap over J37.

1.18 Front Panel Connector

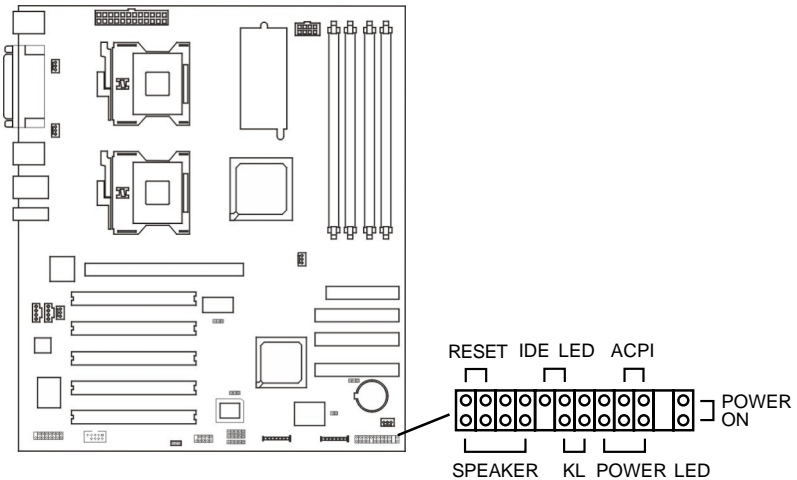

Function

The front panel connector (J44) on the motherboard supports several system indicators and controls that connect to the front panel of the system chassis. This will enable you to determine information about the system's operational status and provide some system controls. These include the:

- **Reset Switch**
This switch connects to the system's Reset button allowing you to restart the system. Do not use the reset button if you can shut the system down from the operating system (OS). Shutting the system down from the OS minimizes the possibility of hard disk drive problems or data loss. However, if your system hangs, you have two hardware reboot options. "Warm" reboot using the <Ctrl> <Alt> keys or using the reset button.
- **IDE LED Connector**
This connector connects to the system's IDE LED. The IDE LED flashes when the hard drive is being accessed.

Components and Features

- **ACPI Switch**
This switch connects to the system's Suspend button allowing the system to enter or resume from the Suspend mode. If your system chassis does not have this button, the same function may be performed from your OS; if it is supported.
- **Power On Switch**
This switch connects to the system's Power button allowing you to power on and off the system. You can configure the system to use the keyboard or mouse to power-on the system. You can also configure the system to respond to power restoration after a power outage occurs. These functions can be configured by making appropriate settings in the Integrated Peripherals submenu ("Super IO Device" field) of the BIOS.
- **Speaker Connector**
This connects to the speaker installed in the system chassis.
- **Keyboard Lock Connector**
This connector connects to the chassis-mounted switch allowing you to use of the keyboard lock feature.
- **Power LED Connector**
This connector connects to the system's Power LED. When the system's power is on, this LED will light.

User's Manual

1.19 Battery and Battery Housing

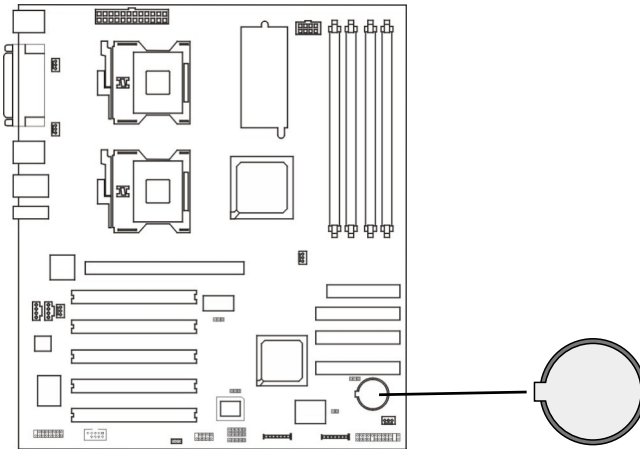

Function

The battery housing is for the CR2032 Lithium coin cell battery. It powers the real-time clock and CMOS memory. When the computer is not plugged into a wall socket, the battery has an estimated life of three years. When the computer is plugged in, the standby current from the power supply extends the life of the battery.

1.20 EPS 12V Power Connectors

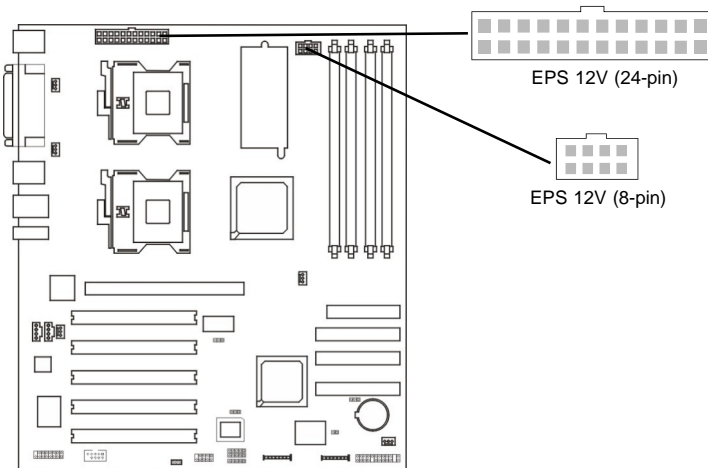

Connecting a 450-Watt EPS 12V Power Supply

The motherboard requires using a 450-Watt EPS 12V power supply. Leads from the power supply will plug into the two power connectors (J1 and J3) on the motherboard. The 24-pin (J1) and 8-pin (J3) power connectors are not standard ATX connectors. These are for connecting to the minimum 450-Watt EPS 12V power supply that complies with the Intel Xeon processor power supply design guidelines.

Connecting a 450-Watt ATX 12V Power Supply onto the EPS Power Connectors

You can use a 450-Watt ATX 12V power supply with this motherboard because the EPS power connectors (J1 and J3) has all the pin signals of the ATX power connectors.

Pins 1-10 and 13-22 of J1 are the same as pins 1-10 and 11-20 of a 20-pin ATX connector.

Pins 1, 2, 5 and 6 of J3 are the same as pins 1-4 of a 4-pin ATX connector.

Refer to the illustrations on the next page for the pin functions of the connectors.

User's Manual

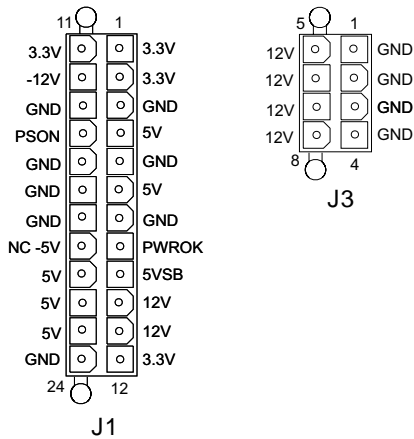

The Xeon processor which is designed for dual processor server and workstation platforms requires more than the power supplied by a 450-Watt ATX 12V power supply. Although you can use a 450-Watt ATX 12V power supply with this motherboard, it is not recommended for long-term use in a server or workstation.

Chapter 2

Hardware Installation

User's Manual

2.1 Jumper Settings

2.1.1 Clear CMOS - JP2

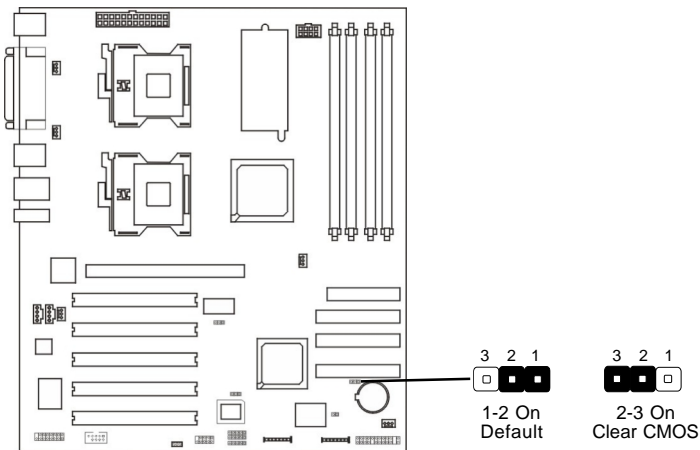

Function

The BIOS CMOS Setup Utility creates system configuration record that is stored in CMOS memory in the real-time clock chip. If the CMOS data becomes corrupted, you can use this jumper to delete the data stored in the CMOS memory and reset the configuration to the CMOS Setup Utility's Optimized Defaults.

Settings

1-2 On Default
2-3 On Clear CMOS

To load the default values stored in the ROM BIOS, please follow the steps below.

1. Power-off the system and unplug the power cord.
2. Remove the chassis cover.
3. Set JP2 pins 2 and 3 to On. Wait for a few seconds.
4. Set JP2 back to its default setting, pins 1 and 2 On.
5. Replace the chassis cover.

Hardware Installation

6. Now power-on the system.
7. After powering-on the system, press to enter the main menu of the BIOS.
8. Select the Load Optimized Defaults submenu and press <Enter>.
9. Type <Y> and press <Enter> to load the optimized default values.
10. Press <Esc> to return to the main menu of the BIOS setup utility.
11. Select the "Save & Exit Setup" submenu then press <Enter>.
12. Type <Y> and press <Enter>.

User's Manual

2.1.2 BIOS Flash Protect - JP3

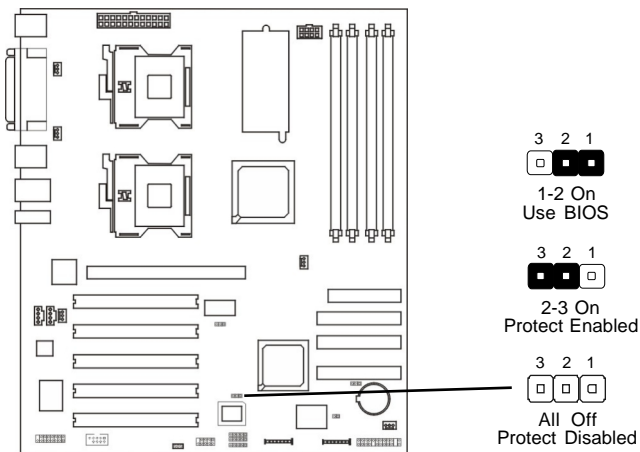

Function

The system BIOS and CMOS Setup Utility are stored in the motherboard's Flash memory which provides permanent storage but is rewritable allowing BIOS updates. This jumper protects the system from unnecessary updating or flashing of the BIOS. It secures the BIOS therefore prevents accidental overwriting of the data stored in Flash memory.

Settings

- 1-2 On Protection mode selected in the "Iwill Smart Setting" submenu of the BIOS. (default)
- 2-3 On BIOS Write Protection Enabled
- All Off BIOS Write Protection Disabled

2.1.3 CPU FSB Select - JP4

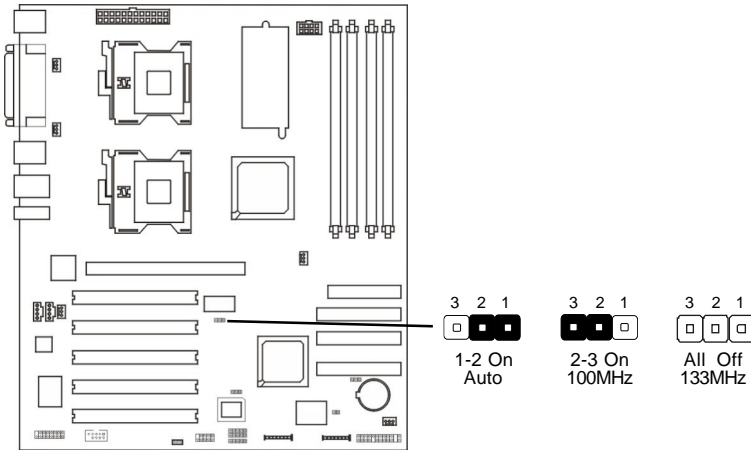

Function

This jumper is used to select the clock speed that is used to generate the Front Side Bus speed (frequency setting x 4). The default setting is Auto. The system will run according to the front side bus of the CPU installed on the system board. You can use this jumper to manually set the speed of the CPU. For example, if you set the jumper to 133MHz, then $133\text{MHz} \times 4 = 533\text{MHz}$ FSB.

Settings

1-2 On Auto. Uses the CPU's frequency (default)
2-3 On 100MHz
All Off 133MHz



Overclocking may result to the CPU's or system's instability and are not guaranteed to provide better system performance. If you are unable to boot your system due to overclocking, make sure to set this jumper back to its default setting.

User's Manual

2.2 CPU Installation

-  Handle the CPU by its edges and avoid touching the pins.
- Always observe precautions against electrostatic discharge.
- The illustrations are generic and do not specifically represent this motherboard.
- Follow the procedure for installing both the CPU and its cooling assembly. Failure to do so can result in either improper operation or damage to the CPU and the motherboard.

2.2.1 Installing the CPU

-  You can install either one or two CPUs.
- When installing one CPU, install it in the CPU1 socket.
- When installing two CPUs, make sure to use identical CPUs. The CPU settings (clock speed and ratio) must also be identical.

The Xeon processor package includes the following items. Please refer to the photo on the left - clockwise from the lower left.



- Xeon processor
- TIM applicator
- Heat sink
- Processor Wind Tunnel
- Retention mechanism
- Heat sink clips
- Mounting screws

Hardware Installation

1. Raise the retaining lever of the CPU locking mechanism to a perpendicular position. Make sure the retaining lever is lifted to the vertical position otherwise the CPU will not fit in properly.



2. Align the CPU to the socket by matching pin 1 of the CPU (marked with a triangle) to pin 1 of Socket 603 (marked with a triangular hole in the pin 1 corner).



User's Manual

3. Insert the CPU into the socket until it is seated in place. The CPU will fit in only one orientation and can easily be inserted without exerting any force.

 Do not force the CPU into the socket. Forcing the CPU into the socket may bend the pins and damage the CPU.



4. Lower the locking mechanism's retaining lever until it latches in place. This should secure the CPU into the socket. Now try to grasp the CPU by the edges and gently pull it upwards. If the CPU did not move, it indicates that it has been properly inserted.



2.2.2 Installing the Retention Mechanisms

The motherboard comes with a pair of Heat Sink Retention Mechanisms. You must attach these to the motherboard before installing the processor heat sink. If you are installing a boxed Intel Xeon processor, it will also come with two Retention Mechanisms. You can use either of them.

To install the provided Heat Sink Retention Mechanisms, please follow the steps below.

1. Align the four standoffs that are on the CPU Backplate (mounting nuts attached to the plate) to the mounting holes which are around one of the CPU sockets on the motherboard.

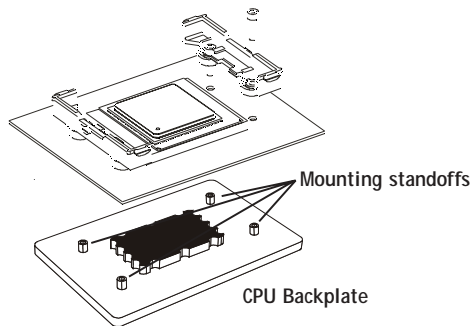

User's Manual

- Each Retention Mechanism has two mounting holes. Align and then position the Retention Mechanism's mounting holes to two of the mounting holes on the motherboard, with the mechanism facing towards the CPU socket.

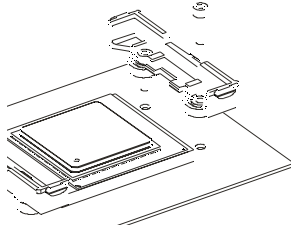

- Insert a screw into the mounting hole of the Retention Mechanism, from the top through to the standoff that is on the CPU Backplate. Gently tighten the screw. Do not overtighten it. This instruction applies to the other mounting hole of the Retention Mechanism.



- Repeat step 3 to install the other Retention Mechanism onto the opposite side of the CPU socket. The mechanisms will hold the CPU Backplate firmly on the underside of the motherboard.
- If you are installing two CPUs, repeat steps 3 and 4.

2.2.3 Installing the Heat Sink

After installing the Retention Mechanisms, the next step is to install a Heat Sink by using the provided heat sink retaining clips.

Applying the Thermal Interface Material

Before you install the heat sink, you must apply the Thermal Interface Material (TIM). TIM is supplied in an applicator that comes with a boxed Intel Xeon processor.

To apply TIM onto the CPU, please follow the steps below.

1. Apply all the TIM in the applicator to the middle of the CPU's heat spreader plate.
2. Do not spread TIM all over the surface. When you place the Heat Sink on top of the CPU, the material will disperse evenly.



User's Manual

Installing the Heat Sink

1. Place the Heat Sink on the CPU in such a way that it fits into the recesses of the Retention Mechanisms. The Heat Sink base is rectangular and will only fit into the mechanism frame in one orientation. Slightly wiggle the Heat Sink after you have placed it on the CPU to disperse the TIM.

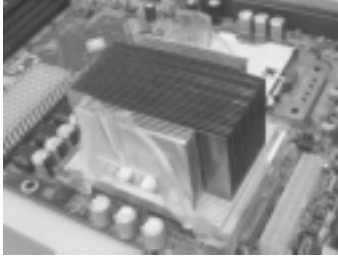

2. Place a heat sink retaining clip onto one of the Retention Mechanisms so that the large outer center tab is on the outside and fits over the extension of the Retention Mechanism. The inner center tab should clip over the edge of the Heat Sink.

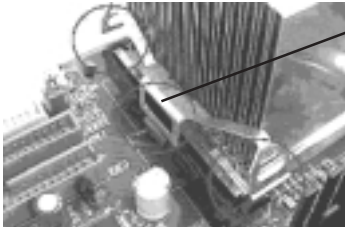

Position the clip so that the large tab is on the outside and fits over the mechanism extension.

Hardware Installation

3. Hold the clip down against the mechanism and press one end of the retaining clip down so that the tab on the end clips securely over the extension on that end of the mechanism.
4. Press the other end of the retaining clip down so that it clips securely over the extension at the other end of the mechanism. The spring tension of the clip should now hold that side of the heat sink securely against the Retention Mechanism.

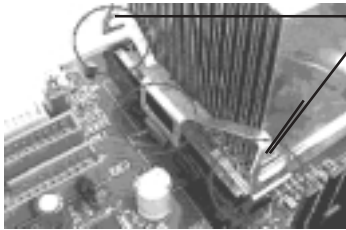

Hold the clip down in the middle while you press the ends of the clip onto the Retention Mechanism.

5. Repeat the procedure above for the Retention Mechanism on the other side of the heat sink. After installing the two retaining clips, the Heat Sink will be securely attached.

User's Manual

Installing the Processor Wind Tunnel

After installing the Xeon processor and heat sink assembly, you must install the Processor Wind Tunnel (PWT) assembly. The PWT is composed of three parts and must be installed in the following order.

- Shroud
- Fan assembly (fan with mounting frame)
- PWT end cap

Step 1: Install the Shroud

Clip the Shroud onto the retaining mechanisms at the corners. It should fit onto the mechanism corners and flexible tabs should snap into place.

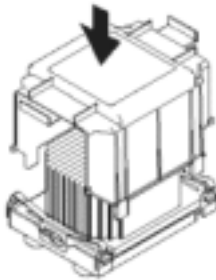

Press the Shroud down onto the Retention Mechanisms until they snap into place

Step 2: Attach the Fan Assembly

1. Clip the fan mounting frame onto the cooling fan. Orient the fan so that it will blow air into the PWT shroud.



Hardware Installation

2. Insert the fan mounting frame tabs into the holes on the forward side of the PWT shroud. The plastic tabs should snap securely into place.

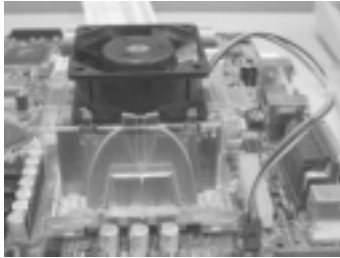

2.3 Memory Installation

The DDR module is held in the socket by the retaining arms on each side. The module's edge connector are of different widths and there are key notches in each module. These ensure that you won't insert the module incorrectly.

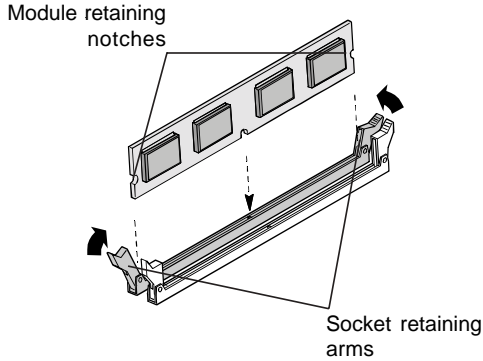

Before you install any modules, you must prepare the required number and type of DDR modules.

1. Align the module to the socket with the “notch” in the module aligned with the “key” on the socket. The module will insert in only one orientation.

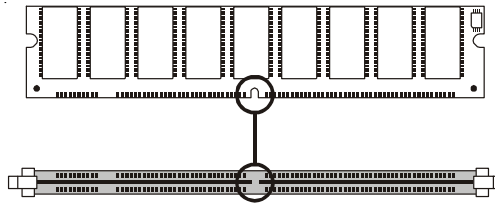

Hardware Installation

2. Hold the module perpendicular to the motherboard and press the edge connector into the socket.

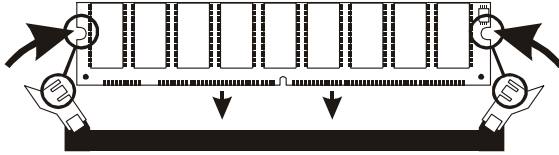

3. Press the module completely into the socket so that the retaining arms will engage the retention notches at each end of the module.



2.4 Motherboard Installation

This section explains the basic requirements for installing the motherboard in a system housing or “chassis”. Since housing designs vary widely, you will need to consult the housing documentation for specific information.

To install the motherboard in a system housing, you will need to do the following:

- Install a rear panel I/O shield
- Attach the board to the housing
- Connect leads from the housing's front panel
- Connect other internal system components.

Motherboard Installation Procedure

The motherboard requires installing the supplied CPU Backplates to mount the heat sink retention mechanisms. Refer to the CPU Installation section in this chapter for details.

If the housing you are using normally stands vertically, place the open housing on it's side before you start.

To install the motherboard, please follow the steps below.

1. Review any instructions that came with the system housing and prepare the necessary mounting hardware that came with it.
2. Identify the mounting holes on the motherboard and confirm that the housing has standoffs that match them.
3. Install the rear panel I/O shield in the housing's I/O panel opening.

Hardware Installation

- Place the motherboard in the housing and align the mounting holes to the standoffs of the housing's motherboard mounting plate. Make sure all of the rear I/O ports are properly aligned with the openings of the I/O panel.
- Secure the motherboard to the housing by inserting mounting screws in all the holes.

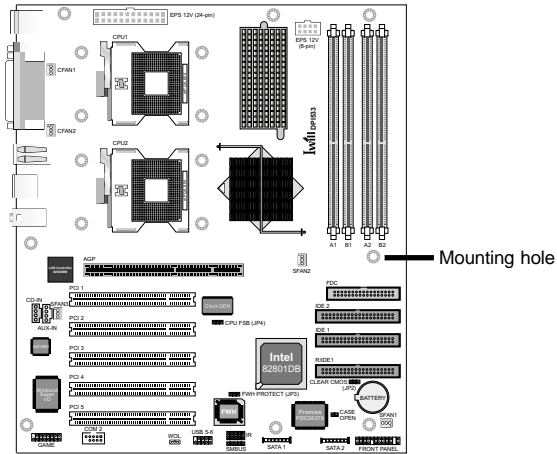

Chapter 3

BIOS

2.1 Overview

The BIOS is a program that takes care of the basic level of communication between the CPU and peripherals. It contains codes for various advanced features found in this motherboard. The BIOS allows you to configure the system and save the configuration in a battery-backed CMOS so that the data retains even when the power is off. In general, the information stored in the CMOS RAM of the EEPROM will stay unchanged unless a configuration change has been made such as a hard drive replaced or a device added.

It is possible that the CMOS battery will fail causing CMOS data loss. If this happens, you need to install a new CMOS battery and reconfigure the BIOS settings.



The BIOS is constantly updated to improve the performance of the motherboard; therefore the BIOS screens in this chapter may not appear the same as the actual one. These screens are for reference purposes only.

2.2 Firmware Configuration

Most of the configuration settings are either predefined by the BIOS Optimized Default settings which are stored with the BIOS or are automatically detected and configured without requiring User action. There are a few settings that you may need to change depending on your system configuration.

2.3 Entering the BIOS Setup Program

The CMOS Setup Utility can only be operated from the keyboard and all commands are keyboard commands. The commands are available at the bottom of the each setup screen.

The CMOS Setup Utility does not require an operating system to run. After you power up the system, the BIOS message appears on the screen and the memory count begins. After the memory test, the message "Press DEL to enter setup" will appear on the screen. If the message disappears before you respond, restart the system or press the "Reset" button. You may also restart the system by pressing the <Ctrl> <Alt> and keys simultaneously.

User's Manual

2.4 Legends

Keys	Function
Up and Down arrows	Moves the highlight up or down between fields.
Right and Left arrows	Moves the highlight left or right between the items in the main menu.
<Esc>	Returns to the previous menu.
<Enter>	Selects the option for the particular field.
<PgUp>	Moves the cursor to the first field.
<PgDn>	Moves the cursor to the last field.
+ (plus key)	Scrolls forward through the values of the highlighted field.
- (minus key)	Scrolls backward through the values of the highlighted field.
<F1>	Displays General Help.
<F5>	Displays the previous value.
<F6>	Loads the Fail-Safe Defaults
<F7>	Loads the Optimized Defaults
<F9>	Shows the menu in the BIOS.
<F10>	Saves and exits the Setup program.

Scroll Bar

When a scroll bar appears to the right of the fields on the setup screen, it indicates that there are more available fields that did not fit in the screen. Use the <PgUp> and <PgDn> or up and down arrow keys to scroll through all the available fields.

Submenu

When a “►” appears on the left of a particular field, it indicates that a submenu which contains additional options are available for that field. To display the submenu, move the highlight to that field and press <Enter>.

3.3 Main Menu

The main menu displays all the available menu items. To select the item you want to configure, move the highlight to the menu item then press <Enter>.



3.3.1 Standard CMOS Features

Standard CMOS Features allows you to configure system settings such as the current date and time, type of hard disk drive installed and display type. Memory size is auto-detected by the BIOS and displayed for your reference.

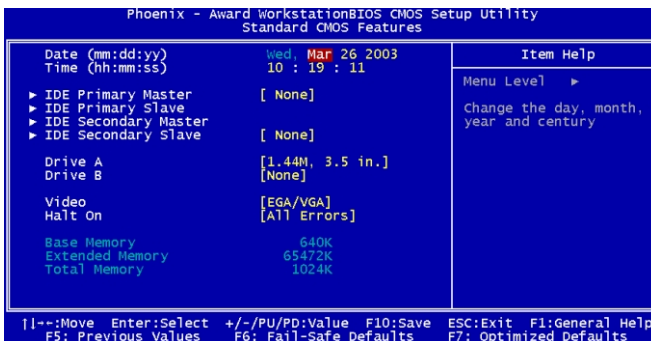

Date

The date format is <day>, <month>, <date>, <year>. Day displays a day, from Sunday to Saturday. Month displays the month, from January to December. Date displays the date, from 1 to 31. Year displays the year, from 1994 to 2079.

User's Manual

Time

The time format is <hour>, <minute>, <second>. The time is based on the 24-hour military-time clock. For example, 1 p.m. is 13:00:00. Hour displays hours from 00 to 23. Minute displays minutes from 00 to 59. Second displays seconds from 00 to 59.

IDE Primary Master, IDE Primary Slave, IDE Secondary Master and IDE Secondary Slave

Move the cursor to the "IDE Primary Master", "IDE Primary Slave", "IDE Secondary Master" or "IDE Secondary Slave" field, then press <Enter>. You can manually configure the IDE drives in this field.

Drive A and Drive B

These fields identify the types of floppy disk drives installed.

Base Memory

Displays the amount of base (or conventional) memory installed in the system. The value of the base memory is typically 512K for systems with 512K memory installed on the motherboard or 640K for systems with 640K or more memory installed on the motherboard.

Extended Memory

Displays the amount of extended memory detected during boot-up.

Total Memory

Displays the total memory available in the system.

3.3.2 Advanced BIOS Features

Advanced BIOS Features allows you to configure your system for basic operation. It mainly configures boot options including boot devices and their boot order and some power functions. Most entries are defaults required by the motherboard, while others, if enabled, will improve the performance of your system or let you set some features according to your preference.

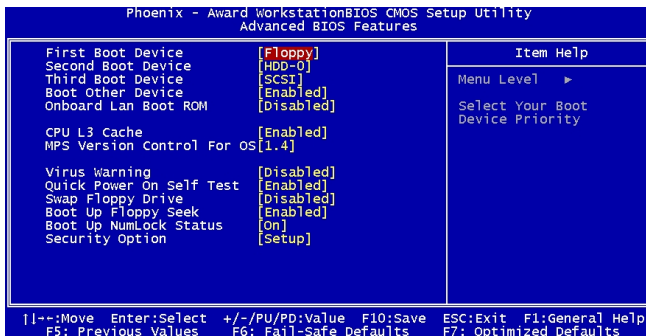

First Boot Device, Second Boot Device, Third Boot Device and Boot Other Device

Select the drive to boot first, second and third in the “First Boot Device” “Second Boot Device” and “Third Boot Device” fields respectively. The BIOS will boot the operating system according to the sequence of the drive selected. Set “Boot Other Device” to Enabled if you wish to boot from another device.

Onboard LAN Boot ROM

Enable this field if you wish to use the boot ROM (instead of a disk drive) to boot-up the system and access the local area network directly.

If you wish to change the boot ROM's settings, type the <Shift> and <F10> keys simultaneously when prompted during boot-up. Take note: you will be able to access the boot ROM's program (by typing <Shift> + <F10>) only when this field is enabled.

User's Manual

Security Option

This field determines when the system will prompt for the password - everytime the system boots or only when you enter the BIOS setup. Set the password in the Set Supervisor/User Password submenu.

- System The system will not boot and access to Setup will be denied unless the correct password is entered at the prompt.
- Setup The system will boot, but access to Setup will be denied unless the correct password is entered at the prompt.

3.3.3 Advanced Chipset Features

Advanced Chipset Features gives you functions to configure the system based on the specific features of the chipset. The chipset manages bus speeds and access to system memory resources. These items should not be altered unless necessary. The default settings have been chosen because they provide the best operating conditions for your system. The only time you might consider making any changes would be if you discovered some incompatibility or that data was being lost while using your system.

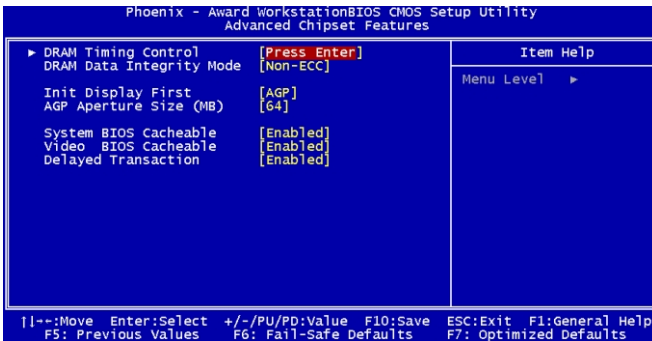

3.3.4 Integrated Peripherals

Integrated Peripherals configures the peripheral features integrated onto the motherboard. All fields in this screen are set to optimized default. If you are going to use the onboard SATA, onboard USB, or onboard audio, you have to enable support for them from this screen.

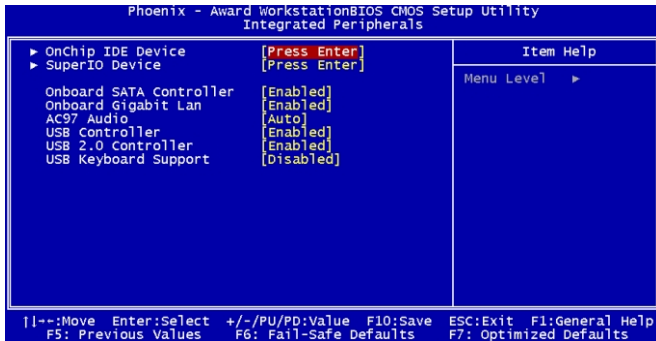

OnChip IDE Device

Move the cursor to this field and press <Enter>. The following screen will appear. The IDE transfer mode settings are autodetected. The system will work with these defaults.

User's Manual

Super IO Device

Move the cursor to this field and press <Enter>. The following screen will appear. The port settings are standard PC settings. You can disable onboard devices and change port settings.

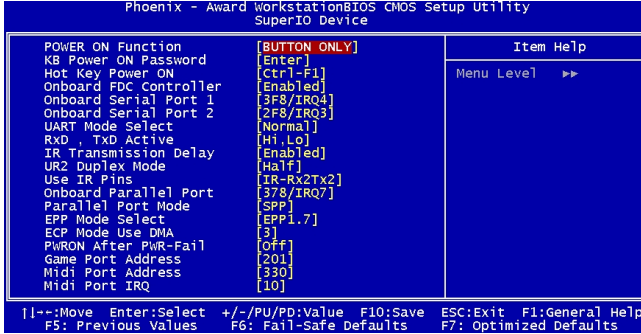

Power On Function

This field allows you to use the keyboard or PS/2 mouse to power-on the system.

- Button only** Default setting. Uses the power button to power on the system.
- Password** When this option is selected, set the password you would like to use to power-on the system in the “KB Power On Password” field.
- Hot Key** When this option is selected, select the function key you would like to use to power-on the system in the “Hot Key Power On” field.
- Mouse Left** When this option is selected, double-click the left button of the mouse to power-on the system.
- Mouse Right** When this option is selected, double-click the right button of the mouse to power-on the system.
- Any Key** Press any key to power-on the system.
- Keyboard 98** When this option is selected, press the “wake up” key of the Windows[®] 98 compatible keyboard to power-on the system.

KB Power On Password

Move the cursor to this field and press <Enter>. Enter your password. You can enter up to 5 characters. Type in exactly the same password to confirm, then press <Enter>.

The power button will not function once a keyboard password has been set in this field. You must type the correct password to power-on the system. If you forgot the password, power-off the system and remove the battery. Wait for a few seconds and install it back before powering-on the system.

Hot Key Power On

This field is used to select a function key that you would like to use to power-on the system.

User's Manual

3.3.5 Power Management Setup

Power Management Setup allows you to configure your system to most effectively save energy. Most of these are overridden by ACPI power management in Windows.

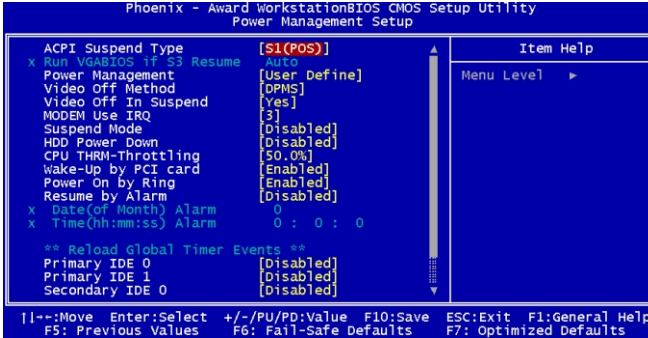

ACPI Suspend Type

This field is used to select the type of Suspend mode.

S1(POS) Enables the Power On Suspend function.

S3(STR) Enables the Suspend to RAM function.

Power Management

This field allows you to select the type (or degree) of power saving by changing the length of idle time that elapses before the HDD Power Down field is activated.

Min Saving Minimum power saving time for the HDD Power Down = 15 min.

Max Saving Maximum power saving time for the HDD Power Down = 1 min.

User Define Allows you to set the power saving time in the “HDD Power Down” field.

Resume By Alarm

Enabled When Enabled, you can set the date and time you would like the Soft Power Down (Soft-Off) PC to power-on in the “Date (of Month) Alarm” and “Time (hh:mm:ss) Alarm” fields. However, if the system is being accessed by incoming calls or the network (Resume On Ring/LAN) prior to the date and time set in these fields, the system will give priority to the incoming calls or network.

Disabled Disables the automatic power-on function. (default)

Date (of Month) Alarm

0 The system will power-on everyday according to the time set in the “Time (hh:mm:ss) Alarm” field.

1-31 Select a date you would like the system to power-on. The system will power-on on the set date, and time set in the “Time (hh:mm:ss) Alarm” field.

Time (hh:mm:ss) Alarm

This is used to set the time you would like the system to power-on. If you want the system to power-on everyday as set in the “Date (of Month) Alarm” field, the time set in this field must be later than the time of the RTC set in the Standard CMOS Features submenu.

User's Manual

3.3.6 PnP/PCI Configurations

PnP/PCI Configurations describes configuring Plug and Play and other PCI bus settings. It covers some very technical items and it is strongly recommended that only experienced users should make any changes to the default settings.

Don't change the resource settings. They're set to be handled automatically by the BIOS. While you can set them manually, there shouldn't be any need to do so.

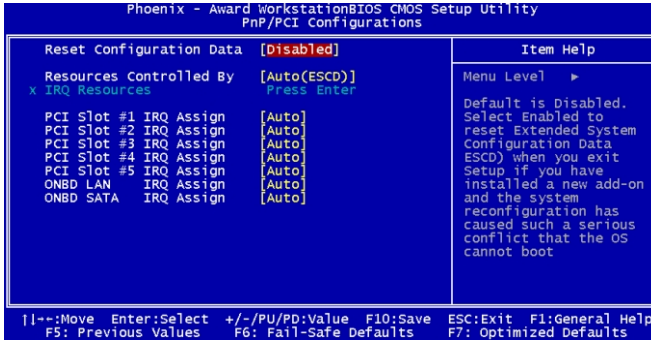

3.3.7 PC Health Status

PC Health Status displays detected system information such as CPU temperature, fan speed and various voltage levels.

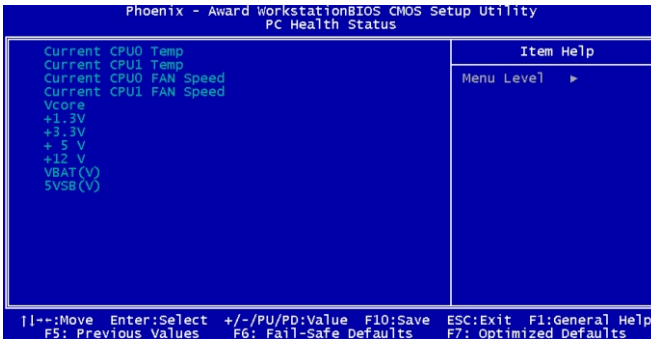

3.3.8 IWILL Smart Setting

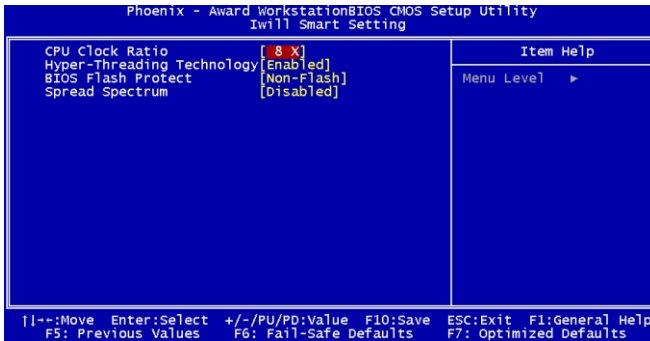

CPU Clock Ratio

This field is used to select the CPU's frequency ratio.

Hyper-Threading Technology

This field is used to enable the functionality of the Intel® Pentium® 4 Processor with Hyper-Threading Technology and will appear only when using this processor.

BIOS Flash Protect

Non-Flash This option will protect the system from unnecessary updating or flashing of the BIOS. When enabled, it secures the BIOS therefore any updates to the BIOS will not take effect.

Flash Disables the "BIOS Flash Protect" function, allowing you to update or flash the BIOS any time needed.

User's Manual

3.3.9 Load Fail-Safe Defaults

Load Fail-Safe Defaults loads the troubleshooting default values permanently stored in the ROM chips. These settings are not optimal and turn off all high performance features. You should use these values only if you have hardware problems.

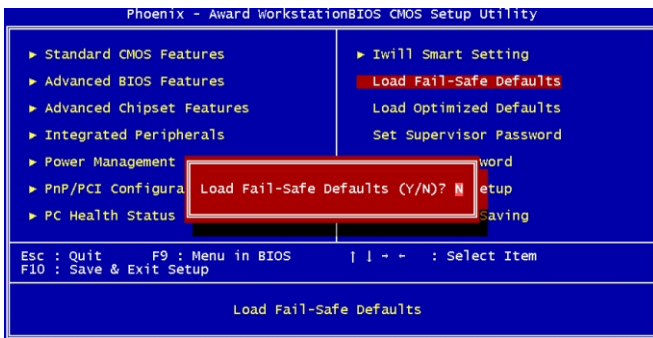

3.3.10 Load Optimized Defaults

Load Optimized Defaults loads optimized settings from the BIOS ROM. Do this if the configuration record has been corrupted or mistakenly configured or after the Clear CMOS procedure has been performed.

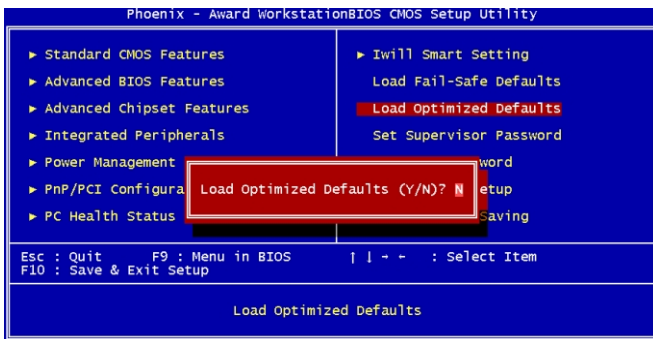

3.1.11 Set Supervisor Password

If you want to protect your system and setup from unauthorized entry, set a supervisor’s password with the “System” option selected in the Advanced BIOS Features. If you want to protect access to setup only, but not your system, set a supervisor’s password with the “Setup” option selected in the Advanced BIOS Features. You will not be prompted for a password when you cold boot the system.

Use the arrow keys to highlight “Set Supervisor Password” and press <Enter>.

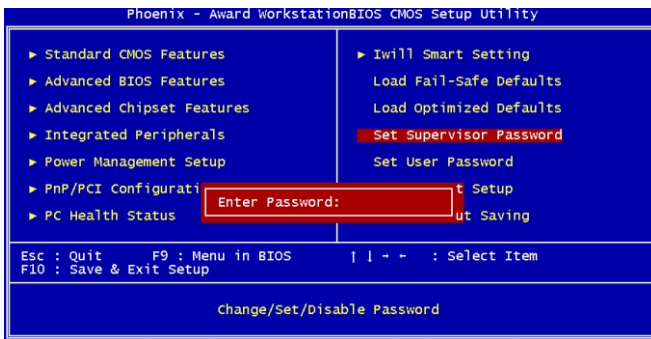

Type in the password. You are limited to eight characters. When done, the message below will appear:

Confirm Password:

You are asked to verify the password. Type in exactly the same password. If you type in a wrong password, you will be prompted to enter the correct password again. To delete or disable the password function, highlight “Set Supervisor Password” and press <Enter>, instead of typing in a new password. Press the <Esc> key to return to the main menu.

User's Manual

3.1.12 Set User Password

If you want another user to have access only to your system but not to setup, set a user's password with the "System" option selected in the Advanced BIOS Features. If you want a user to enter a password when trying to access setup, set a user's password with the "Setup" option selected in the Advanced BIOS Features.

Using user's password to enter Setup allows a user to access only "Set User Password" that appears in the main menu screen. Access to all other options is denied.

Use the arrow keys to highlight "Set User Password" and press <Enter>.

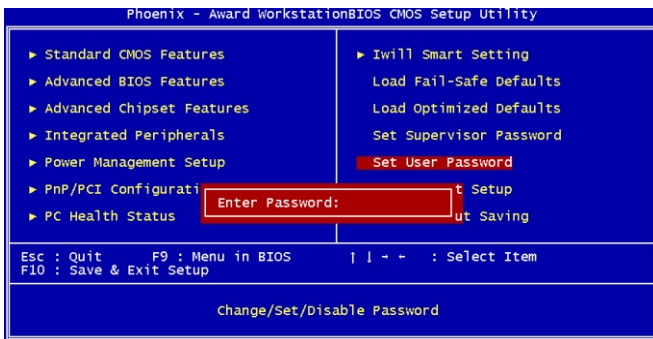

Type in the password. You are limited to eight characters. When done, the message below will appear:

Confirm Password:

You are asked to verify the password. Type in exactly the same password. If you type in a wrong password, you will be prompted to enter the correct password again. To delete or disable the password function, highlight "Set User Password" and press <Enter>, instead of typing in a new password. Press the <Esc> key to return to the main menu.

3.1.13 Save & Exit Setup

When all the changes have been made, highlight “Save & Exit Setup” and press <Enter>.

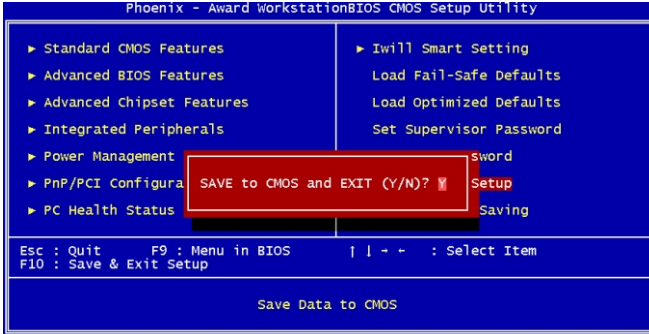

Type “Y” and press <Enter>. The modifications you have made will be written into the CMOS memory, and the system will reboot. You will once again see the initial diagnostics on the screen. If you wish to make additional changes to the setup, press <Ctrl> <Alt> <Esc> simultaneously or after memory testing is done.

User's Manual

3.1.14 Exit Without Saving

When you do not want to save the changes you have made, highlight "Exit Without Saving" and press <Enter>.

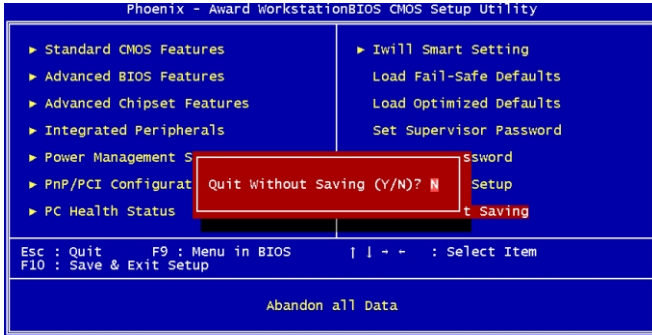

Type "Y" and press <Enter>. The system will reboot and you will once again see the initial diagnostics on the screen. If you wish to make any changes to the setup, press <Ctrl> <Alt> <Esc> simultaneously or after memory testing is done.

Chapter 4

Drivers and Utilities

User's Manual

5.1 The Power Installer CD

The motherboard package includes the Power Installer CD which contains drivers and utilities designed to make your computer run better.

5.2 Supported OS

The motherboard supports the following Operating System:

- Microsoft Windows 2000
- Microsoft Windows XP Professional
- Red Hat Linux (or compatible distribution)

If you are using a Microsoft OS, you must install the drivers and utilities for that particular OS. If you are using Linux, you must create supports disks using the Make Driver utility.

5.3 Running the Power Installer CD

To begin using the CD, insert the CD into a CD-ROM drive. The Power Installer main screen will appear. Click the motherboard's model name to access its main menu. If the Power Installer main screen did not appear, locate and double-click the Setup file from the root directory of the CD.

5.4 Main Menu

After selecting the motherboard's model name, the main menu will appear. The main menu displays the image of the motherboard and buttons that link you to the drivers, user's manual and utilities.

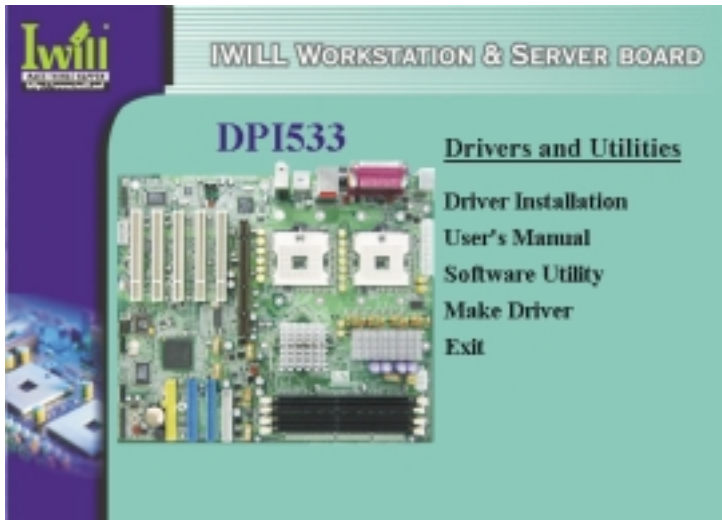

The Picture shows above for reference only. Different models from DPI533 series (DPI533-SATA, DPI533-L, DPI533) provides each driver/ softwares for installation.

Please choose proper item shown from the "Power Installer CD".

User's Manual

5.4.1 Driver Installation

Click "Driver Installation" on the main menu. The screen below will appear.



1. Install "Intel INF Driver". Click on this button then follow the instructions on the screen to complete the installation.
2. Install "Audio Driver". Click on this button then follow the instructions on the screen to complete installation.
3. Click "Lan Driver Installation Guide", "USB 2.0 Installation Guide", "ATA133 Installation Guide" and/or "SATA Raid Installation Guide" to read the installation instruction for the OS you are using then install the appropriate drivers for that OS.

5.4.2 Software Utility

Click “Software Utility” on the main menu. The screen below will appear.



Adobe Acrobat Reader

Acrobat Reader allows you to read documents that are in Adobe PDF format which includes online documents on the CD and a wide range of other content. The reader is free and upgrade versions can be downloaded from the Adobe web site - www.adobe.com.

Hardware Monitor Utility

The onboard hardware monitor function is capable of detecting the CPU temperature, CPU fan speed and voltages. If you want a warning message to pop-up or a warning alarm to sound when an abnormal condition occurs, you must install the Hardware Monitor utility.

User's Manual

5.4.3 Make Driver

You can make driver floppy disks by running the "Make Driver" utility. Click "Make Driver" on the main menu to run the utility then follow the instructions on the screen.

Chapter 5

Technical Specifications

User's Manual

5.1 Specifications

Processor

- Dual Intel® Xeon™ processors at 400/533MHz FSB
- System bus: 100/133MHz
- Auto detect CPU type for external clock and multiplier settings

Processor Sockets

- Two mPGA604 sockets

CPU Power

- Compliant to VRM 9.1 specification
- VRD design

Memory

- Four DDR DIMM sockets
 - Supports dual channel memory interface
 - Each channel supports 2 DIMM sockets
- Supports up to 8GB memory
- PC1600 (DDR200) or PC2100 (DDR266) DDR SDRAM modules
- Supports ECC memory
- Supports unbuffered DIMMs
- Supports maximum of 8GB memory using 128Mbit, 256Mbit, 512Mbit or 1Gbit technology
- Peak memory bandwidth: 4.2GB/s

Chipset

- North bridge: Intel E7505 Memory Controller Hub (MCH) - 133MHz FSB
- South bridge: 82801DB I/O Controller Hub (ICH4) - 266MB/s
- Winbond Super I/O - W82627HF

Graphics

- One AGP Pro slot
- AGP 8x (2.13GB/sec bandwidth)
- AGP 4x (1066MB/sec. bandwidth)
- AGP Pro 50 (The slot is extended to support AGP Pro cards that use up to 50 watts of power)

Technical Specifications

PCI

- Five 32-bit, 33MHz PCI slots
- PCI 2.1/2.2 compliant

LAN

- Intel LAN controller
 - Kenai 32 82540EM Gigabit ethernet LAN controller (DPI533 and DPI533-SATA only)
 - Intel 82551QM 10/100 LAN interface (DPI533-L only)
- High-speed 1Gigabit/sec data transfer
- Supports 10-BaseT and 100Base-TX
- Supports Wake-On-LAN

RAID (DPI533-SATA only)

- Promise PDC20378 controller
- Supports 2 serial ATA interfaces with speed of up to 1.5Gbps and one IDE connector
- Supports RAID level 0, 1 and 0+1

USB

- Four onboard USB ports for rear panel connection
- One 9-pin connector for 2 front panel USB ports connection

Audio

- AC'97 software sound
- Analog device AD1980
- Line-in, line-out and mic-in jacks
- Rear-out, Center-out and S/PDIF jacks
- One 4-pin CD-in header
- One 4-pin AUX-in header

User's Manual

Rear Panel I/O

- Stacked PS/2 mouse and PS/2 keyboard ports
- Stacked one parallel, one serial, rear out, center out and S/PDIF out
- Stacked one RJ45 LAN port (with LEDs) on dual USB 2.0 ports
- Stacked dual USB 2.0 ports
- Stacked line-in, line-out and mic-in jacks

General I/O

- Two IDE connectors that support up to four Ultra DMA 33, ATA/66 and ATA/100 drives
- One floppy connector that supports two drives
- Two serial ATA connectors and one IDE RAID connector (DPI533-SATA only)
- One COM 1 port
- One 9-pin connector for external COM 2 connection
- One 15-pin connector for external game/MIDI connection
- One 25-pin parallel port
- One PS/2 keyboard port
- One PS/2 mouse port
- One SMBus connector
- One Wake On LAN connector
- One IR connector

BIOS

- Award BIOS
- Supports Flash Write Protect function
- Supports ACPI - S1 and S3
- BIOS event logging feature setup
- BIOS setup features
- Auto configuration of IDE hard disk type
- Multiple boot options

System Management

- Winbond hardware monitor
- Two 3-pin CPU fan headers
- Three 3-pin system fan headers
- Three temperature sensors
- Seven monitored voltages - Vcore, +1.5V, +2.5V, +3.3V, +5V, +12V, 5VSTB and battery
- One 3-pin chassis intrusion header

Technical Specifications

Power

- EPS 12V
 - 24-pin system power connector
 - 8-pin connector to support VRD
- ATX 12V
 - 20-pin system power connector
 - 4-pin connector

Form Factor

- ATX

Others

- Supports AC power failure
- PCB - 6 layers
- Specifications
 - ACPI 1.1
 - PC 2001
 - PCI 2.2
 - APM 1.2
 - SMBIOS 2.3
 - BIOS boot spec. 1.01
 - WFM 2.0
 - DMI 2.0

Certification

- FCC class B
- CE mark 89/336/ECC(EMV) and according to EU
- WHQL
 - Windows 2000
 - Windows XP

User's Manual

5.2 Connector Pinouts

CPU and System Fan Headers

- 1 Ground
- 2 +12V
- 3 Sense

Front USB Headers

- | | |
|----------------|----------------|
| 1 +5V (fused) | 2 +5V (fused) |
| 3 USB Data (-) | 4 USB Data (-) |
| 5 USB Data (+) | 6 USB Data (+) |
| 7 Ground | 8 Ground |
| 9 Key | 10 NA |

CD-ROM Audio-In Header

- 1 Left Channel Input
- 2 Ground
- 3 Ground
- 4 Right Channel Input

Front Audio Header

- | | |
|----------------|-----------------|
| 1 Mic In | 2 Ground |
| 3 Mic Power | 4 Audio Power |
| 5 RT Line Out | 6 RT Line Out |
| 7 Reserved | 8 Key |
| 9 LFT Line Out | 10 LFT Line Out |

Auxiliary Audio Header

- 1 Left channel AUX_IN
- 2 Ground
- 3 Ground
- 4 Right channel AUX_IN

IR Header

- 1 Voltage 5V
- 2 Key
- 3 IR_RX
- 4 GND
- 5 IR_TX

Chapter 6

Performance Optimization

User's Manual

This section covers things you can do to increase the performance of your system.

6.1 System Memory

Increasing the system memory size will improve the system's performance and capability under any of the supported Operating System.

The motherboard supports a total of 8GB system memory. If you have not installed the maximum, you can consider increasing the memory size. Adding system memory speeds up the system operation and in some cases provide additional stability to the Operating System.

6.2 Disk Subsystem

This motherboard supports IDE drives with data transfer modes of up to ATA-100. If you are using IDE drives as the primary disk subsystem, selecting drives that support ATA-100 and have a high rotation speed (at least 7,200rpm) will maximize performance.

6.3 Processor Upgrades and Adjustments

Processor speed has a significant effect on the overall system performance. To increase system performance, you can consider using or upgrading to a faster processor.

The Intel Xeon processors supported by this motherboard come in a variety of clock speeds. If you install dual processors, they must have the same specification. If you upgrade one, you must upgrade both. The CMOS Setup Utility's Iwill Smart Setting feature will automatically detect and configure the installed processors. The Intel Xeon processor should not be set to operating parameters other than its defaults.

Chapter 7

Troubleshooting

User's Manual

This section details things you can do to evaluate problems that could possibly occur in the course of using this motherboard. The topics covered include possible hardware problems and problems with the CMOS Setup Utility's system configuration record.

7.1 Hardware Problems

A hardware problem may occur either after you installed additional hardware or because some existing hardware failed or has a disconnected or loose connection. This section has some pointers on things you can check before seeking assistance.

General Hardware Troubleshooting

If the motherboard does not operate properly when you first try to use it in the system, it is likely that it is either configured incorrectly or there are problems with the external connections. It is also possible the board or some other system component is defective. Always check the most common possibilities first.

- First, check the external components.
 - Make sure the system, the monitor and all other external peripherals are plugged in and turned on.
 - Make sure the system and the power LEDs of the external peripherals are on.
 - Make sure the monitor, keyboard and mouse are properly connected.
- Second, check the CMOS Setup Utility.
 - Run the CMOS Setup Utility and load the Optimized Defaults. Reset any other custom settings. Remember to "Save & Exit Setup" to restart the computer.

Troubleshooting

- Third, check the internal components. Turn off and unplug the system before you remove the system housing cover.
 - Make sure all DIMMs are properly installed in the module sockets.
 - Make sure you used the correct cables to connect the internal peripherals and that the peripherals are properly connected to the motherboard. Check the Master/Slave positions of all IDE cables. If you installed a device that uses ATA-100 mode, make sure you used an ATA-100 cable to connect it to the motherboard so as to ensure maximum performance.
 - Check that all expansion cards are correctly installed and fully inserted in the expansion slots. Pay particular attention to the AGP display card.
 - Make sure the processor and its cooling assembly are properly installed.
 - Check all the hardware settings on the motherboard and make sure they are correct.

When you're done, reassemble the system and try again. If the problem persists after you have checked all of the above, there may be a hardware conflict or bug. See the next section for additional information.

Hardware Configuration Conflicts

It is possible for system hardware components to conflict with each other. While all the components and subsystems on the motherboard are designed and tested to work together, expansion cards and peripheral devices can be a problem.

Assuming you have gone through the general troubleshooting procedures and the system still will not start, and you have earlier added a new hardware to your system, there may be a hardware conflict or bug or a problem with a device driver. Try removing the new hardware and see if the system will start. If it does, consult the device manufacturer for information on solving the problem. In some cases, a firmware or driver upgrade may resolve the problem.

User's Manual

Plug and Play Problems

The motherboard supports automatic recognition and configuration of expansion cards that support the Plug and Play (PnP) specification. Most currently available expansion cards support PnP. PnP simplifies card installation by allowing the system to handle system resource allocation.

If you installed an expansion card that is not PnP compliant, you need to configure the card manually. Consult the card's documentation for instructions or other information.

Replacing the System Configuration Record

As noted previously, the CMOS Setup Utility creates a system configuration record and stores it in CMOS memory on the motherboard. The record must be correct and not corrupt for the system to operate properly.

However, it is possible that the system's configuration record will corrupt and you will lose the data. If this occurs, the system will not operate properly or will not operate at all. This is not a serious problem. You can restore it by using the CMOS Setup Utility to create a new configuration record. Load the Optimized Defaults and re-enter any other settings you had made.

Loading Optimized Defaults

The BIOS Setup Utility does not require an operating system to run. Run the utility by typing the Del key while the system is starting up.

There are two sets of defaults, Optimized and Fail-Safe. The Fail-Safe Defaults are a minimum configuration set for use by technicians when troubleshooting system problems. The Optimized Defaults are what the system normally operates on. If a corrupted system configuration record caused the problem you experienced, once you load the Optimized Defaults and rebooted, the system should function normally. Refer to the BIOS chapter in this manual for more information.