



## 586 GX-A V Main Board

### User's Manual version 1.0

## Introduction

This Cyrix Media GXi all in one system board offers the latest technology interface and supports the high performance Cyrix GXi, processors operating from 166MHz to 233MHz.

On board VGA supports 1280x1024 with 256 color and 1024x768 with 16bit color, Audio controller compatible with Sound Blaster 16/Pro.

The AWARD BIOS with deep green power management functions, plug & play auto configuration and board support up to 128MB of memory will maximize the latest operating software applications.

## Features

CPU, Sound and Video Chipset :

- Cyrix Media Gxi 166/180/200/233 MHz CPU .
- Cyrix XpressAudio Sound / Sound Blaster Compatible.
- Cyrix XpressGraphic Video using VSA Technology.
- Support Mpeg decoding and VCD playback

Enhanced I/O Chipset :

- ITE 8680/8687 for 2.88 MB FDD, Enhanced I/O 16550 /ECP/EPP bi-direction.

VGA to TV Chipset : ( Optional )

- Chrontel CH7002.

Memory :

- Support 64 bit memory, 4 x 72 pin SIMM socket.
- Support single side or double side SIMM two banks.
- 4 MB to 32 MB SIMM, 8 MB up to 128 MB memory.

Expansion slots :

- 2 x 16 bit ISA slots, 2 x 64 bit PCI ver. 2.1 master

slots.

System BIOS function :

- Award Deep Green BIOS.
- Plug and Play PnP function.
- Auto configuration for PCI add-on cards.
- I/O Device's power saving, APM, SMI.
- Support flash memory for ESCD function.

Enhanced PCI IDE and ISA I/O :

- Build in Enhanced PCI Local Bus IDE Controller.
- Support 4 PCI IDE devices.
- Support 2 FDD upto 2.88 MB.
- PS/2 Mouse port.
- USB port.
- Two Fast Serial ports with 16550.
- One Multi mode Parallel port ( ECP/EPP ).
- One Game port.

Attachments :

- |                                |     |
|--------------------------------|-----|
| HDD cable                      | x 1 |
| FDD cable                      | x 1 |
| Serial port cable              | x 1 |
| Printer port cable             | x 1 |
| Sound Port bracket w/cable     | x 1 |
| VGA and TV out bracket w/cable | x 1 |

Software Drivers :

- Bundled VGA and Sound Drivers for MS/DOS, OS/2, Windows, Windows NT, Windows 95, Novell, UNIX, SCO, XENIX.

Dimension :

- 220 mm x 220 mm

## Layout and Position

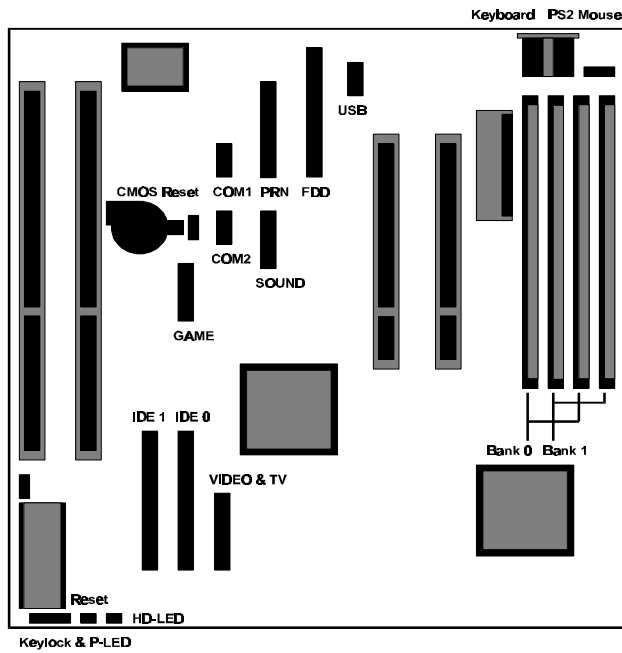

Reset	Reset Switch
HD-LED	Hard Disk LED
Keylock & P-LED	Power LED & Key Lock
JP7	2-3 Default
	1-2 Clean CMOS Setting
PRN	Parallel port
COM 1,2	Serial ports 1,2
FDD	Floppy Disk Drive Connector
IDE 0	Primary IDE Connector
IDE 1	Secondary IDE Connector
USB	USB ports 1,2
PS/2 Mouse	PS/2 Mouse Connector
Game	Game port Connector
Sound	Sound board Connector
Video & TV	Video board Connector

## LINE IN

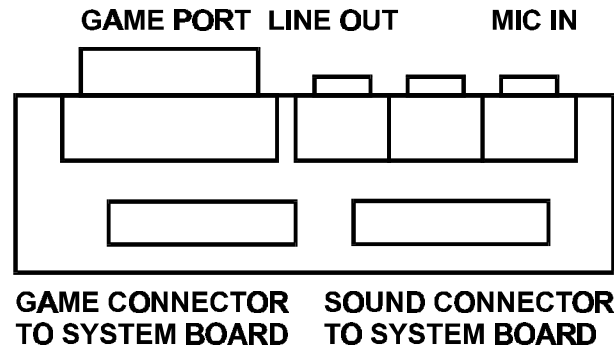

## S-VIDEO OUT

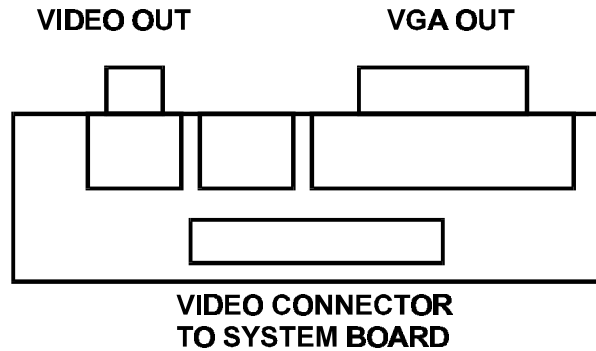

## Memory Configuration

The board support 72 pin Fast Page or EDO SIMMs DRAM whatever single side or double side. There is no jumper nor connector need for configuration. SIMMs can be use parity (x36) or none parity (x32). The 70ns fast page SIMM or 60ns EDO DRAM is needed, at least.

Bank 0	Bank 1	Bank 0	Bank 1	Total
4MBSS		4MBSS		8MB
4MBSS	4MBSS	4MBSS	4MBSS	16MB
8MBDS		8MBDS		16MB
8MBDS	4MBSS	8MBDS	4MBSS	24MB
8MBDS	8MBDS	8MBDS	8MBDS	32MB
16MBSS		16MBSS		32MB
16MBSS	4MBSS	16MBSS	8MBSS	40MB
16MBSS	8MBSS	16MBSS	8MBSS	48MB
16MBSS	16MBSS	16MBSS	16MBSS	64MB
32MBDS		32MBDS		64MB
32MBDS	4MBSS	32MBDS	4MBSS	72MB
32MBDS	8MBSS	32MBDS	8MBSS	80MB
32MBDS	16MBSS	32MBDS	16MBSS	96MB
32MBDS	32MBDS	32MBDS	32MBDS	128MB

SS = Single side SIMM RAM module  
 DS = Double side SIMM RAM module

## Software Installation

Please refer to 'readme.txt' file in the driver diskette.

Trademarks and/or registered trademarks are the properties of their respective owners.

The information presented in this publication has been carefully reviewed for reliability; However, no responsibility is assumed for inaccuracies. Specifications are subjected to change without prior notice.