

BC133KT
USER'S MANUAL

M/B For Socket-A Athlon/Duron Processor

<http://www.bcmcom.com>

BC133KT

Release date: September 2000

**** Year 2000 compliant ****

Trademark:

* Specifications and Information contained in this documentation are furnished for information use only, and are subject to change at any time without notice, and should not be construed as a commitment by manufacturer.

TABLE OF CONTENT

USER'S NOTICE	1
MANUAL REVISION INFORMATION	2
COOLING SOLUTIONS	2
CHAPTER 1 INTRODUCTION OF BC133KT MOTHERBOARD	
1-1 FEATURE OF MOTHERBOARD.....	3
1-2 SPECIFICATION	4
1-3 PERFORMANCE LIST.....	5
1-4 LAYOUT & JUMPER SETTING	6
CHAPTER 2 HARDWARE INSTALLATION	
2-1 HARDWARE INSTALLATION STEPS.....	8
2-2 CHECKING MOTHERBOARD'S JUMPER SETTING.....	8
2-3 INSTALL CPU	9
2-3-1 ABOUT AMD ATHLON & DURON 462-PIN CPU	9
2-3-2 INSTALL CPU	10
2-4 INSTALL MEMORY	11
2-5 EXPANSION CARD	12
2-5-1 PROCEDURE FOR EXPANSION CARD INSTALLATION.....	12
2-5-2 ASSIGNING IRQ FOR EXPANSION CARD	12
2-5-3 INTERRUPT REQUEST TABLE FOR THIS MOTHERBOARD	13
2-5-4 AGP SLOT.....	13
2-6 CONNECTORS, HEADERS.....	14
2-6-1 CONNECTORS.....	14
2-6-2 HEADERS.....	18
2-7 STARTING UP YOUR COMPUTER.....	21
CHAPTER 3 INTRODUCING BIOS	
3-1 ENTERING SETUP.....	22
3-2 GETTING HELP.....	23
3-3 THE MAIN MENU	24
3-4 STANDARD CMOS FEATURES.....	25
3-5 ADVANCED BIOS FEATURES	27
3-6 ADVANCED CHIPSET FEATURES	30
3-6-1 ADVANCED DRAM CONTROL.....	32
3-6-2 ADVANCED AGP CONTROL.....	33
3-7 INTEGRATED PERIPHERALS.....	34
3-7-1 ONCHIP IDE FUNCTION.....	35
3-7-2 ONCHIP DEVICE FUNCTION	36
3-7-2.1 ONCHIP AUDIO FUNCTION.....	37
3-7-3 ONCHIP SUPERIO FUNCTION	38
3-8 POWER MANAGEMENT SETUP	40

3-8-1	POWER MANAGEMENT	42
3-8-2	WAKE UP EVENTS.....	43
	3-8-2.1	IRQS ACTIVITY MONITORING..... 44
3-9	PNP/PCI CONFIGURATION SETUP.....	45
3-10	PC HEALTH STATUS.....	46
3-11	FREQUENCY/VOLTAGE CONTROL	47
3-12	LOAD STANDARD/OPTIMIZED DEFAULTS	48
3-13	SET SUPERVISOR/USER PASSWORD	49

USER'S NOTICE

COPYRIGHT OF THIS MANUAL BELONGS TO **THE MANUFACTURER**. NO PART OF THIS MANUAL, INCLUDING THE PRODUCTS AND SOFTWARE DESCRIBED IN IT MAY BE REPRODUCED, TRANSMITTED OR TRANSLATED INTO ANY LANGUAGE IN ANY FORM OR BY ANY MEANS WITHOUT WRITTEN PERMISSION OF **THE MANUFACTURER**.

THIS MANUAL CONTAINS ALL INFORMATION REQUIRED TO USE 663AS MOTHERBOARD AND WE DO ASSURE THIS MANUAL MEETS USER'S REQUIREMENT BUT WILL CHANGE, CORRECT ANY TIME WITHOUT NOTICE. **MANUFACTURER** PROVIDES THIS MANUAL "AS IS" WITHOUT WARRANTY OF ANY KIND, AND WILL NOT BE LIABLE FOR ANY INDIRECT, SPECIAL, INCIDENTAL OR CONSEQUENTIAL DAMAGES (INCLUDING DAMAGES FOR LOSS OF PROFIT, LOSS OF BUSINESS, LOSS OF USE OF DATA, INTERRUPTION OF BUSINESS AND THE LIKE).

PRODUCTS AND CORPORATE NAMES APPEARING IN THIS MANUAL MAY OR MAY NOT BE REGISTERED TRADEMARKS OR COPYRIGHTS OF THEIR RESPECTIVE COMPANIES, AND THEY ARE USED ONLY FOR IDENTIFICATION OR EXPLANATION AND TO THE OWNER'S BENEFIT, WITHOUT INTENT TO INFRINGE.

Manual Revision Information

Reversion	Revision History	Date
1.01	Release	September 2000

Item Checklist

- BC133KT
- Cable for IDE/Floppy
- CD for motherboard utilities
- Cable for USB Port 3/4 (Option)
- Cable for COM2
- BC133KT User's Manual

AMD-Duron™ Processor Family

Cooling Solutions

As processor technology pushes to faster speeds and higher performance, thermal management becomes increasingly crucial when building computer systems. Maintaining the proper thermal environment is key to reliable, long-term system operation. The overall goal in providing the proper thermal environment is keeping the processor below its specified maximum case temperature. Heatsinks induce improved processor heat dissipation through increased surface area and concentrated airflow from attached fans. In addition, interface materials allow effective transfers of heat from the processor to the heatsink. For optimum heat transfer, AMD recommends the use of thermal grease and mounting clips to attach the heatsink to the processor.

When selecting a thermal solution for your system, please refer to the website below for collection of heatsinks evaluated and recommended by AMD for use with AMD processors. Note, those heatsinks are recommended for maintaining the specified Maximum T case requirement. In addition, this collection is not intended to be a comprehensive listing of all heatsinks that support AMD processors.

For vendor list of heatsink and fan, please visit :
<http://www1.amd.com/products/duron/thermals>

Chapter 1

Introduction of BC133KT Motherboard

1-1 Feature of motherboard

The BC133KT motherboard is design for use AMD Athlon/Duron CPU, which utilize the Socket-A design and the memory size expandable to 1.5GB.

This motherboard use the newest VIA KT-133 chipset, whose 100MHz front side bus & 133MHz memory interface delivers a clear upgrade path to the future generation of 100MHz processors and PC-133 SDRAM. The BC133KT motherboard offers ULTRA ATA 66. This provides speedier HDD throughout that boosts overall system performance.

The BC133KT also has an integrated AC'97 2.1 CODEC on board which is fully compatible with Sound Blaster Pro® that gives you the best sound quality and compatibility. For those wanting even greater graphic performance, an AGP 4X slot is included on the board.

With 2 USB control as well as capability of expanding to 4 USB connectors, the BC133KT meet future USB demand also this motherboard has built-in hardware monitor function. This will monitor and protect your computer.

This motherboard supports standard Synchronous DRAM (SDRAM) and Virtual Channel SDRAM (VC SDRAM), in a flexible mix/match manner.

This motherboard provides high performance & meets future specification demand. It is really wise choice for your computer.

1-2 Specification

Spec	Description
Design	* ATX form factor 4 layers PCB size: 30.5x21cm
Chipset	* VIA KT-133 Chipset
CPU Socket	* Support AMD Athlon 700~1GHz processor * Support AMD Duron 600~750MHz processor * Support 100MHz F.S.B. * Support 200MHz (Double Data Rate) * Reserves support for future AMD Athlon/Duron processors
Memory Socket	* 168-pin DIMM socket x3 * PC-100/PC-133 SDRAM/Virtual Channel SDRAM (VC SDRAM) * Expandable to 1.5GB * Support 3.3V SDRAM DIMM
Expansion Slot & Headers	* AGP slot x1 support AGP 2.0 & 4X mode * 32-bit PCI slot x5 * AMR slot x1 * ISA slot x1
Integrate IDE	* 2 channel of Bus Master IDE port supporting ULTRA DMA 33/66 mode devices
Audio	* AC'97 Digital Audio controller integrated * AC'97 Audio CODEC on board * Audio driver and utility included
BIOS	* Award 2MB Flash ROM
Multi I/O	* PS/2 keyboard and PS/2 mouse connectors * Floppy disk drive connector x1 * Parallel port x1 * Serial port x2 * USB connector x2 * USB headers x2 (connecting cable option) * Audio connector (Line-in, Line-out & Game Port)

1-3 Performance List

The following performance data list is the testing result of some popular benchmark testing programs. These data are just referred by users, and there is no responsibility for different testing data values gotten by users (the different Hardware & Software configuration will result in different benchmark testing results.)

CPU: AMD K7 900MHz FC-PGA package
DRAM: 128M SDRAM x2 (Hyundai GM 72V66841ET75)
 128M PC-133 VCM SDRAM x2 (NEC D4565821G5)
VGA Expansion Card: Geforce 256 (1024x768 Hi-color) Driver V3.68
Hard Disk Driver: Quantum Fireball KX20A11
BIOS: Award Optimal default
OS: Win 98SE
A: PC-133 SDRAM
B: VCM SDRAM

Performance Test Report

	PC-133 SDRAM		VCM SDRAM	
	100/100	100/133	100/100	100/133
3D Mark 99	5848	5849	5820	5853
3D Mark 2000	4187	4213	4163	4207
3D Winbench 99 V1.2	899	900	899	900
3D Winbench 2000	79.2	80.1	78.7	80.2
Final Reality	6.32	6.30	6.27	6.52
Winstone 99 V1.3	32.7	32	32	32.1
Winstone 2000	37.6	37.3	36.7	37.2
Winbench 99 :				
CPU Mark 99	82	82.5	80.2	82
FPU Winmark 99	4920	4920	4920	4920
Busniess Disk Winmark99	4860	4820	4810	4940
Hi-end Disk Winmark99	17000	16900	16900	17000
Business Graphic Winmark	419	420	416	420
Hi-end Graphic Winmark	1230	1240	1220	1250
SYS Mark 2000 : SISMark 2000 Rating (Internet Content Creation / Office Productivity)				
Suites	184	183	179	184
Offical	182	182		
SISOFT Sandra 2000 :				
CPU MIPS	2830	2814	2826	2821
FPU MFLOPS	1213	1257	1213	1213
CPU / Memory MB/S	391	417	413	470
FPU / Memory MB/S	422	500	460	565
QUAKE3 :				
DEMO1 FPS	103.5	105.0	99.7	104.6
DEMO2 FPS	100.7	102.5	97.0	102.1
	BY SPD	BY SPD	BY SPD	BY SPD

1-4 Layout & Jumper Setting

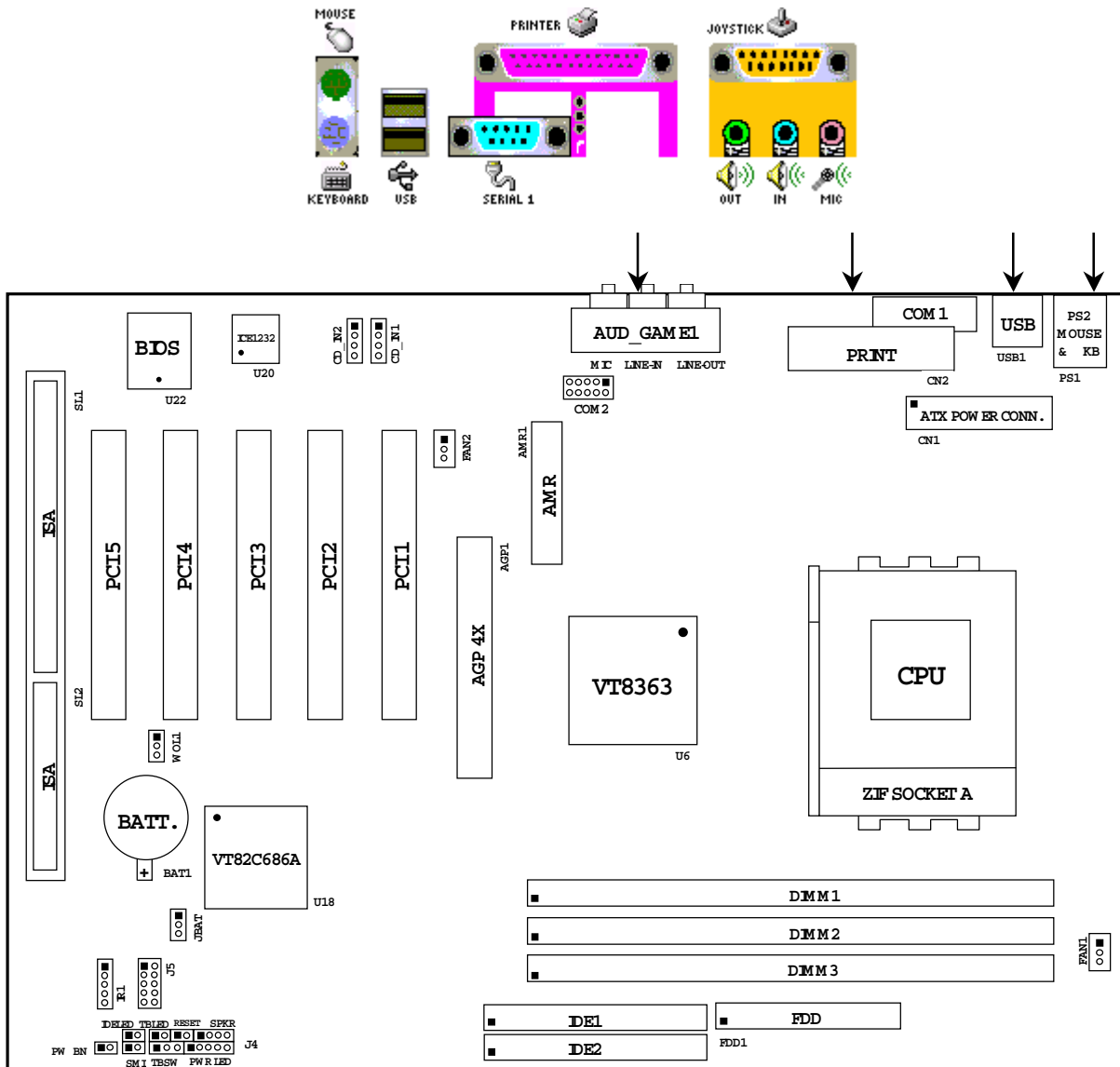

Jumpers

Jumper	Name	Description	Page
JBAT	CMOS RAM Clear	3-pin Block	p.8

Connectors

Connector	Name	Description	Page
CN1	ATX Power Connector	20-pin Block	p.13
PS1	PS/2 Mouse & PS/2 Keyboard Connector	6-pin Female	p.13
USB1	USB Port Connector	4-pin Connector	p.13
CN2	Parallel Port Connector	25-pin Female	p.13
AUD_GAME1	Audio/Game Connector	3 phone jack + 15-pin Connector	p.13
COM1	Serial Port COM1 Connector	9-pin Connector	p.15
FDD1	Floppy Driver Connector	34-pin Block	p.15
IDE1	Primary IDE Connector	40-pin Block	p.15
IDE2	Secondary IDE Connector	40-pin Block	p.16

Headers

Header	Name	Description	Page
COM2	COM2 Headers	10-pin Block	p.16
J5	USB Port Headers	10-pin Block	p.17
IDELED	IDE activity LED	2-pin Block	p.17
TBLED	Turbo LED switch	2-pin Block	p.17
RESET	Reset switch lead	2-pin Block	p.17
SPKR	Speaker connector	4-pin Block	p.17
PWR LED	Power LED	2-pin Block	p.17
PW BN	Power switch	2-pin Block	p.17
WOL1	Wake On-LAN Headers	3-pin Block	p.18
FAN1,FAN2	FAN Speed Headers	3-pin Block	p.18
IR1	IR infrared module Headers	5-pin Block	p.18
CD_IN1,CD_IN2	CD Audio-In Headers	4-pin Block	p.19

Expansion Sockets

Socket/Slot	Name	Description	Page
ZIF Socket 462	CPU Socket	462-pin PPGA CPU Socket	p.9
DIMM1, DIMM2 DIMM3	DIMM Module Socket	168-pin DIMM SDRAM Module Expansion Socket	p.10
PCI1, PCI2, PCI3, PCI4, PCI5	PCI Slot	32-bit PCI Local Bus Expansion slots	p.12
AGP	AGP 4X Mode Slot	AGP Expansion Slot	p.12
ISA	ISA Slot	16-bit ISA BUS Expansion Slot	p.12

Chapter 2

Hardware installation

2-1 Hardware installation Steps

Before using your computer, you had better complete the following steps:

1. Check motherboard setting
2. Install CPU
3. Install Memory
4. Install Expansion cards
5. Connect Ribbon cables, Panel wires, and power supply
6. Setup BIOS
7. Install software driver & utility

2-2 Checking Motherboard's Jumper Setting

1. CMOS RAM Clear (3-pin JBAT)

A battery must be used to retain the motherboard configuration in CMOS RAM short 1-2 pins of JBAT to store the CMOS data.

Note: You can clear CMOS by shorting 2-3 pin, while the system is off. Then return to 1-2 pin position. Avoid clearing the CMOS while the system is on, it will damage the motherboard always unplug the power cord from the wall socket.

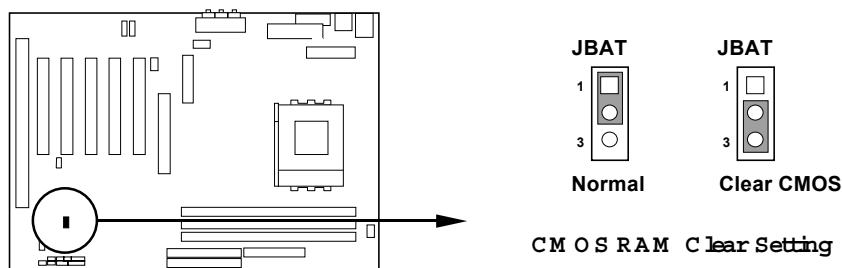

2-3 Install CPU

2-3-1 About AMD Athlon & Duron 462-pin CPU

This motherboard supports Socket-A (Socket-462) AMD Athlon/Duron processors.

Glossary:

Chipset (or core logic) - two or more integrated circuits which control the interfaces between the system processor, RAM, I/O devices, and adapter cards.

Processor slot/socket - the slot or socket used to mount the system processor on the motherboard.

Slot (AGP, PCI, ISA, RAM) - the slots used to mount adapter cards and system RAM.

AGP - Accelerated Graphics Port - a high speed interface for video cards; runs at 1X (66MHz), 2X (133MHz), or 4X (266MHz).

PCI - Peripheral Component Interconnect - a high speed interface for video cards, sound cards, network interface cards, and modems; runs at 33MHz.

ISA - Industry Standard Architecture - a relatively low speed interface primarily used for sound cards and modems; runs at approx. 8MHz.

Serial Port - a low speed interface typically used for mouse and external modems.

Parallel Port - a low speed interface typically used for printers.

PS/2 - a low speed interface used for mouse and keyboards.

USB - Universal Serial Bus - a medium speed interface typically used for mouse, keyboards, scanners, and some digital cameras.

Sound (interface) - the interface between the sound card or integrated sound connectors and speakers, mic, game controllers, and MIDI sound devices.

LAN (interface) - Local Area Network - the interface to your local area network.

BIOS (Basic Input/Output System) - the program logic used to boot up a computer and establish the relationship between the various components.

Driver - software, which defines the characteristics of a device for use by another device or other software.

Processor - the "central processing unit" (CPU); the principal integrated circuit used for doing the "computing" in "personal computer"

Front Side Bus Frequency

The working frequency of the motherboard, which is generated by the clock generator for CPU, DRAM and PCI BUS.

CPU L2 Cache

The flash memory inside the CPU, normally Athlon CPU has 256K or above, while Duron will have 64K.

2-3-2 Install CPU

This motherboard Provides a ZIF Socket-A. The CPU that comes with the motherboard should have a cooling FAN attached to prevent overheating. If this is not the case, then purchase a correct cooling FAN before you turn on your system.

WARNING! Be sure that there is sufficient air circulation across the processor's heatsink and CPU cooling FAN is working correctly, otherwise it may cause the processor and motherboard overheat and damage, you may install an auxiliary cooling FAN, if necessary.

IMPORTANT NOTICE: CPU Heat Sink Fan MUST be connected to the FAN1 in order for the system to boot. The feature protects the motherboard and CPU from the heat damage. By connecting the CPU Heat Sink Fan to FAN2 will not enable this feature.

To install a CPU, first turn off your system and remove its cover. Locate the ZIF socket and open it by first pulling the level sideways away from the socket then upward to a 90-degree angle. Insert the CPU with the correct orientation as shown below. The notched corner should point toward the end of the level. Because the CPU has a corner pin for two of the four corners, the CPU will only fit in the orientation as shown.

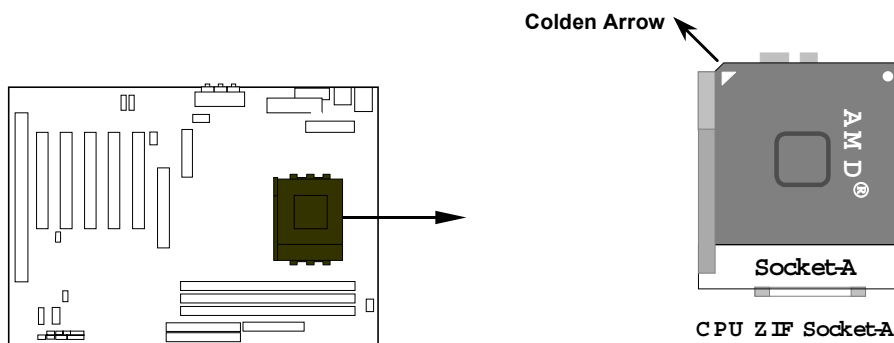

When you put the CPU into the ZIF socket. No force require to insert of the CPU, then press the level to Locate position sightly without any extra force.

2-4 Install Memory

This motherboard provides three 168-pin DUAL INLINE MEMORY MODULES (DIMM) sites for memory expansion available from minimum memory size of 32MB to maximum memory size of 1.5GB SDRAM.

Valid Memory Configurations

Bank	168-Pin DIMM		Total Memory
Bank 0, 1 (DIMM1)	SDRAM 32, 64, 128, 256, 512MB	X1	32MB~512MB
Bank 2, 3 (DIMM2)	SDRAM 32, 64, 128, 256, 512MB	X1	32MB~512MB
Bank 4, 5 (DIMM3)	SDRAM 32, 64, 128, 256, 512MB	X1	32MB~512MB
Total	System Memory (Max. 1.5GB)		32MB~1.5GB

NOTE! Make sure the total installed memory does not exceeds 1.5GB, otherwise the system may hang during startup.

Generally, installing SDRAM modules to your motherboard is very easy, you can refer to figure 2-4 to see what a 168-Pin PC100 & PC133 SDRAM module looks like.

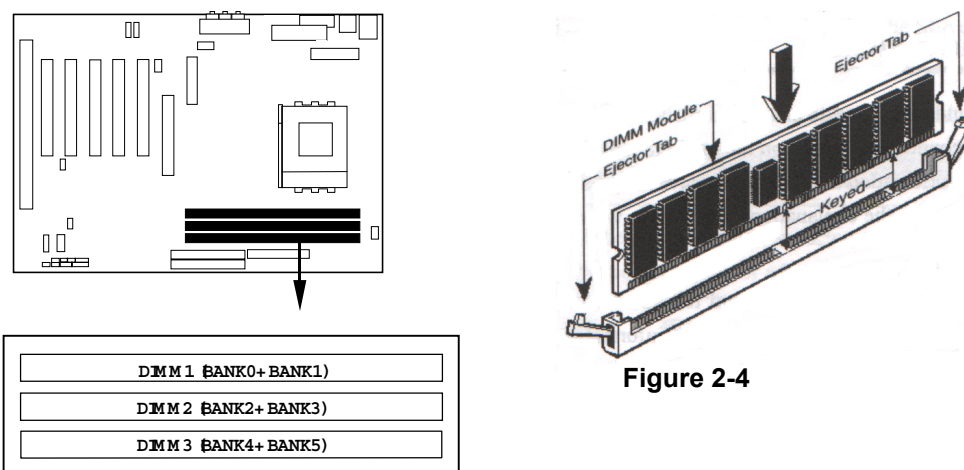

Figure 2-4

NOTE! When you install DIMM module fully into the DIMM socket the eject tab should be locked into the DIMM module very firmly and fit into its indentation on both sides.

WARNING! For the SDRAM CLOCK is set at 133MHz, use only PC133-compliant DIMMs. When this motherboard operate at 133Mhz, most system will not even boot if non-compliant modules are used because of the strick timing issues, if your DIMM are not PC133-compliant, set the SDRAM clock to 100MHz to ensure system stability.

2-5 Expansion Cards

WARNING! Turn off your power when adding or removing expansion cards or other system components. Failure to do so may cause severe damage to both your motherboard and expansion cards.

2-5-1 Procedure For Expansion Card Installation

1. Read the documentation for your expansion card and make any necessary hardware or software setting for your expansion card such as jumpers.
2. Remove your computer's cover and the bracket plate on the slot you intend to use.
3. Align the card's connectors and press firmly.
4. Secure the card on the slot with the screen you remove above.
5. Replace the computer system's cover.
6. Set up the BIOS if necessary.
7. Install the necessary software driver for your expansion card.

2-5-2 Assigning IRQs For Expansion Card

Some expansion cards need an IRQ to operate. Generally, an IRQ must exclusively assign to one use. In a standard design, there are 16 IRQs available but most of them are already in use.

Standard Interrupt Assignments

IRQ	Priority	Standard function
0	N/A	System Timer
1	N/A	Keyboard Controller
2	N/A	Programmable Interrupt
3 *	8	Communications Port (COM2)
4 *	9	Communications Port (COM1)
5 *	6	Sound Card (sometimes LPT2)
6 *	11	Floppy Disk Controller
7 *	7	Printer Port (LPT1)
8	N/A	System CMOS/Real Time Clock
9 *	10	ACPI Mode when enabled
10 *	3	IRQ Holder for PCI Steering
11 *	2	IRQ Holder for PCI Steering
12 *	4	PS/2 Compatible Mouse Port
13	N/A	Numeric Data Processor
14 *	5	Primary IDE Channel
15 *	1	Secondary IDE Channel

* These IRQs are usually available for ISA or PCI devices.

2-5-3 Interrupt Request Table For This Motherboard

Interrupt request are shared as shown the table below:

	INT A	INT B	INT C	INT D
PCI slot 1	Shared	—	—	—
PCI slot 2	—	Shared	—	—
PCI slot 3	—	—	Not Shared	—
PCI slot 4	—	—	—	Shared
PCI slot 5	Shared	—	—	—
AGP slot	Shared	—	—	—
AC97/MC97	—	—	Shared	—
Onboard USB 0	—	—	—	Shared
Onboard USB 1	—	—	—	Shared

IMPORTANT! If using PCI cards on shared slots, make sure that the drivers support “Shared IRQ” or that the cards don’t need IRQ assignments. Conflicts will arise between the two PCI groups that will make the system unstable or cards inoperable.

2-5-4 AGP Slot

This motherboard provides an AGP Slot, support the 1X/2X/4X AGP VGA card.

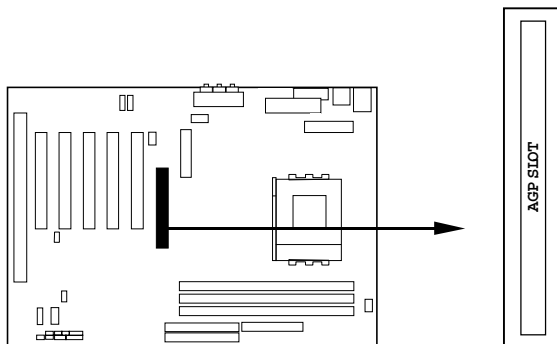

2-6 Connectors, Headers

2-6-1 Connectors

(1) Power Connector: CN1 (20-pin block)

ATX Power Supply connector. This is a new defined 20-pins connector that usually comes with ATX case. The ATX Power Supply allows to use soft power on momentary switch that connect from the front panel switch to 2-pins Power On jumper pole on the motherboard. When the power switch on the back of the ATX power supply turned on, the full power will not come into the system board until the front panel switch is momentarily pressed. Press this switch again will turn off the power to the system board.

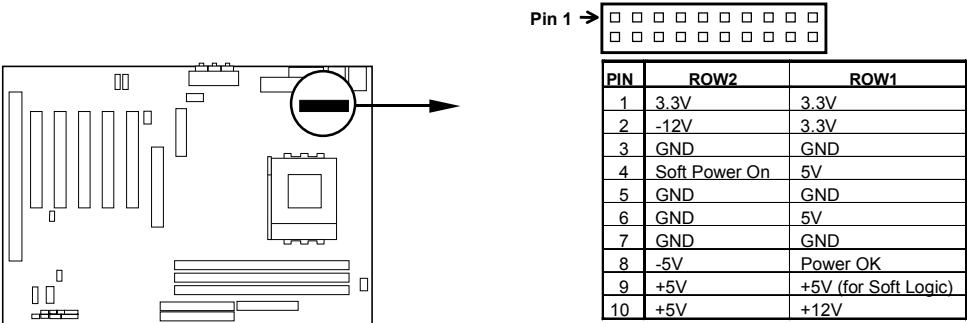

(2) PS/2 Mouse & PS/2 Keyboard Connector: PS1

The connectors for PS/2 keyboard and PS/2 Mouse.

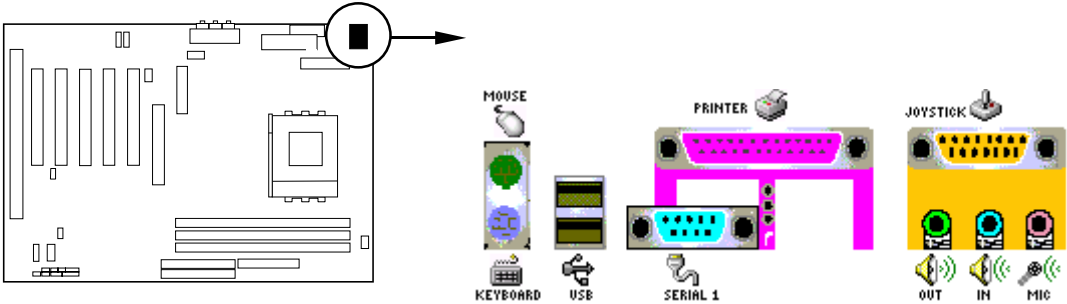

(3) USB Port connector: USB1

The connectors are 4-pin connector that connect USB devices to the system board.

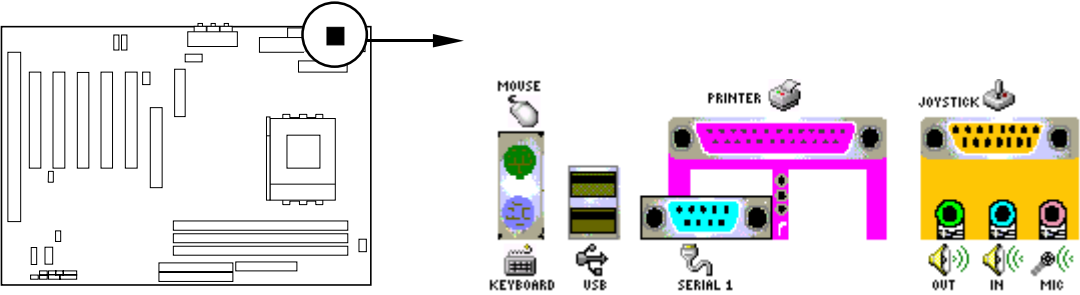

(4) Parallel Port Connector (25-pin female): CN2

Parallel Port connector is a 25-pin D-Subminiature Receptacle connector. The On-board Parallel Port can be disabled through the BIOS SETUP. Please refer to Chapter 3 “INTEGRATED PERIPHERALS SETUP” section for more detail information.

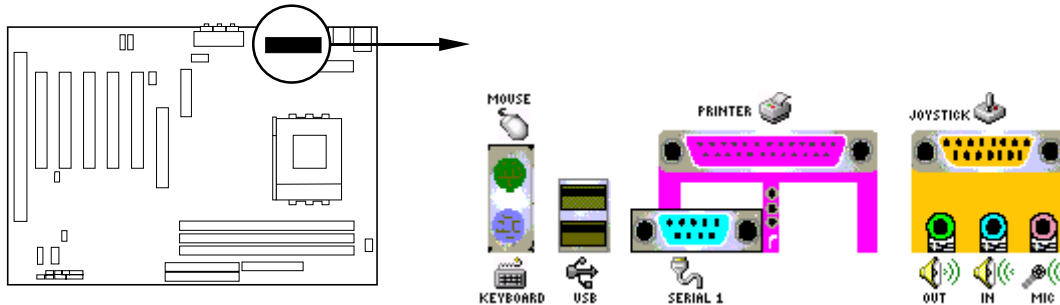

(5) Audio and Game Connector : AUD_GAME

This Connector are 3 phone Jack for LINE-OUT, LINE-IN, MIC and a 15-pin D-Subminiature Receptacle Connector for joystick/MIDI Device.

- Line-out :** Audio output to speaker
- Line-in :** Audio input to sound chip
- MIC :** Microphone Connector
- Game/MIDI :** For joystick or MIDI Device

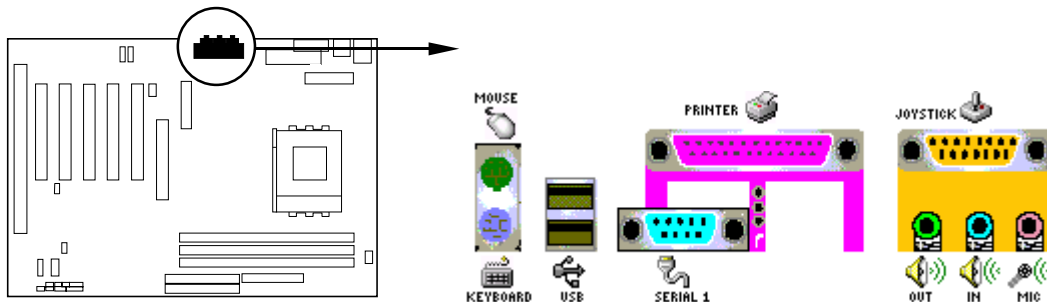

(6) Serial Port COM1: COM1

COM1 is the 9-pin D-Subminiature mail connector. The On-board serial port can be disabled through BIOS SETUP. Please refer to Chapter 3 “INTEGRATED PERIPHERALS SETUP” section for more detail information.

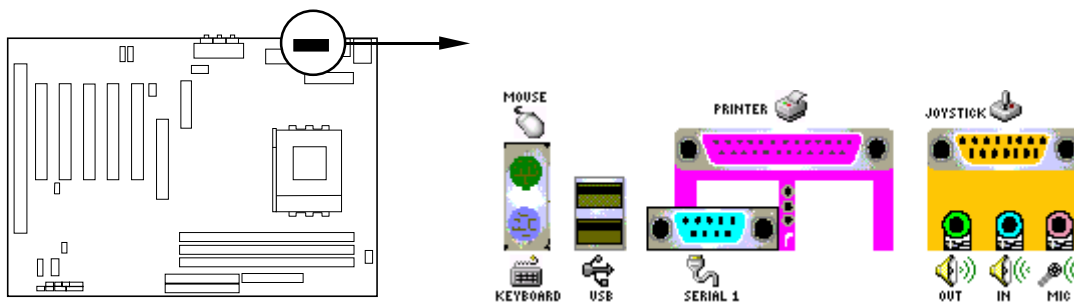

(7) Floppy drive Connector (34-pin block): FDD1

This connector supports the provided floppy drive ribbon cable. After connecting the single plug end to motherboard, connect the two plugs at other end to the floppy drives.

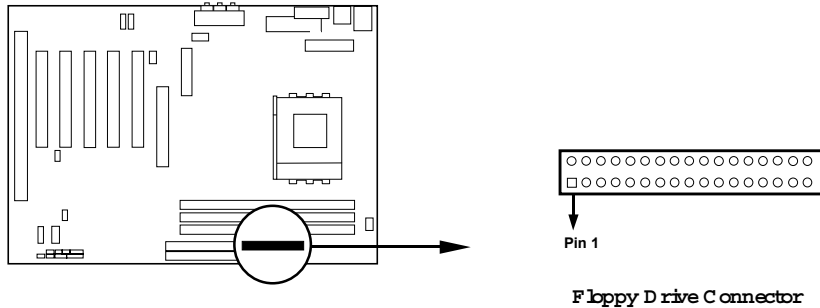

(8) Primary IDE Connector (40-pin block): IDE1

This connector supports the provided IDE hard disk ribbon cable. After connecting the single plug end to motherboard, connect the two plugs at other end to your hard disk(s). If you install two hard disks, you must configure the second drive to Slave mode by setting its jumpers accordingly. Please refer to the documentation of your hard disk for the jumper settings.

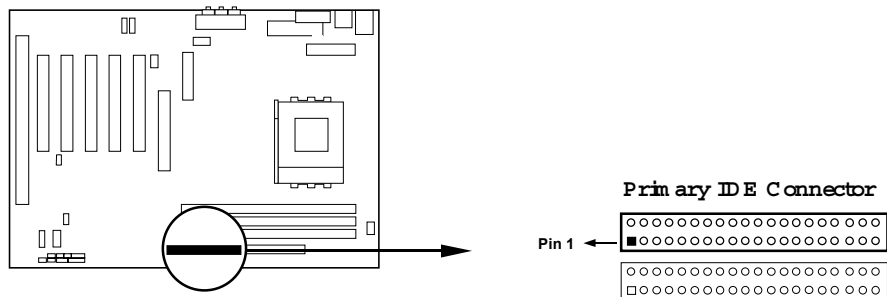

(9) Secondary IDE Connector (40-pin block): IDE2

This connector connects to the next set of Master and Slave hard disks. Follow the same procedure described for the primary IDE connector. You may also configure two hard disks to be both Masters using one ribbon cable on the primary IDE connector and another ribbon cable on the secondary IDE connector.

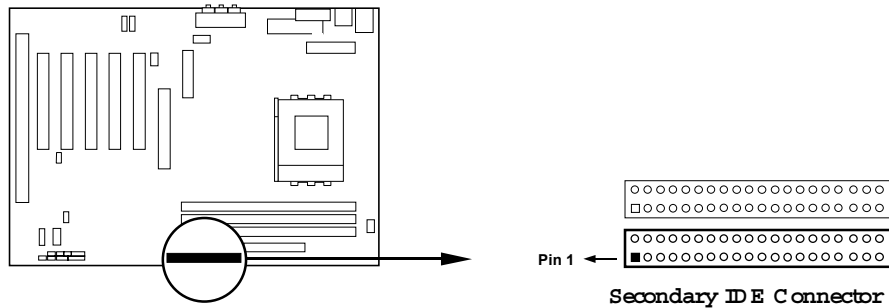

- Two hard disks can be connected to each connector. The first HDD is referred to as the “Master” and the second HDD is referred to as the “Slave”.
- For performance issues, we strongly suggest you don’t install a CD-ROM or DVD-ROM drive on the same IDE channel as a hard disk. Otherwise, the system performance on this channel may drop.

2-6-2 Headers

(1) COM2 Headers (10-pin COM2)

This board has another serial port COM2, it come with cable providing serial port COM2.

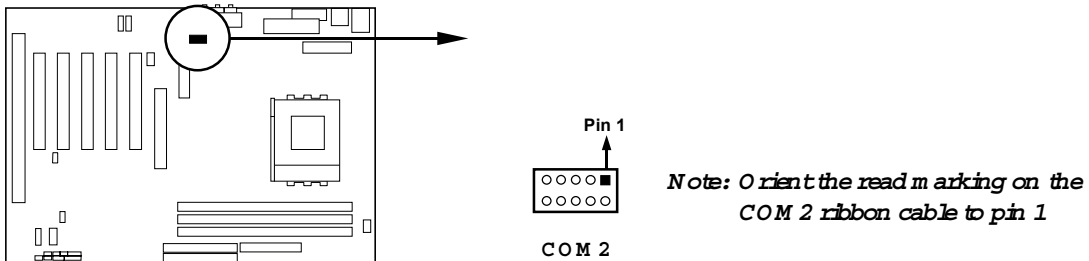

(2) USB Port Headers (10-pin J5)

These headers are used for connecting the additional USB port plug. By attaching an option USB cable, your can be provided with two additional USB plugs affixed to the back panel.

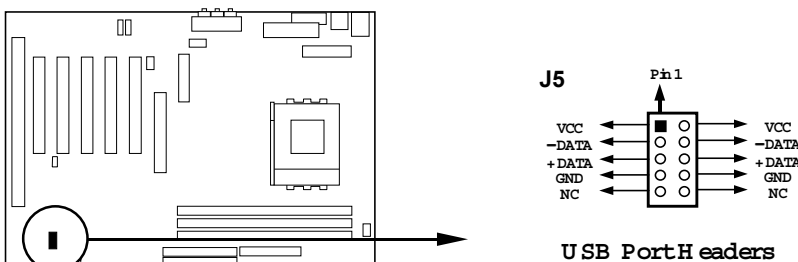

(3) IDE Activity LED: IDELED

This connector connects to the hard disk activity indicator light on the case.

(4) Turbo LED switch: TBLED

Since the motherboard's turbo function is always on. The turbo LED will remain constantly on while the system power is on. You may wish to connect the Power LED from the system case to this lead. See the figure below.

(5) Reset switch lead: RESET

This 2-pin connector connects to the case-mounted reset switch for rebooting your computer without having to turn off your power switch. This is a preferred method of rebooting in order to prolong the life of the system's power supply. See the figure below.

(6) Speaker connector: SPKR

This 4-pin connector connects to the case-mounted speaker. See the figure below.

(7) Power LED: PWR LED

The Power LED is light on while the system power is on. Connect the Power LED from the system case to this pin.

(8) Power switch: PW BN

This 2-pin connector connects to the case-mounted power switch to power ON/OFF the system.

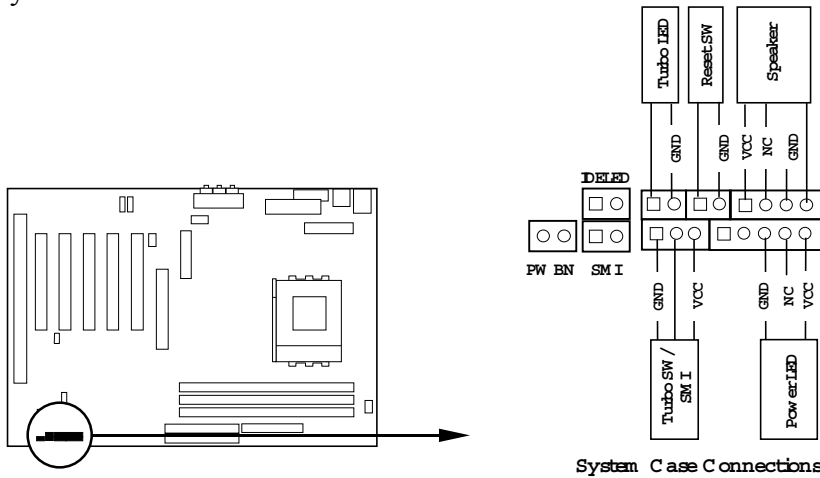

(9) Wake On-LAN Headers: (3-pin WOL1)

This connector connects to a LAN card with a WAKE ON-LAN output. This connector power up the system when a wake up signal is received through the LAN card.

NOTE: This feature requires that Wake On LAN or Ring In Wake up is enabled.

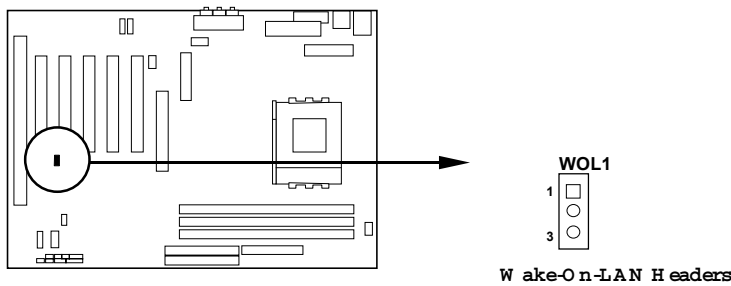

(10) FAN Speed Headers: (3-pin FAN1, FAN2)

These connectors support cooling fans of 350mA (4.2 Watts) or less, depending on the fan manufacturer, the wire and plug may be different. The red wire should be positive, while the black should be ground. Connect the fan's plug to the board taking into consideration the polarity of connector.

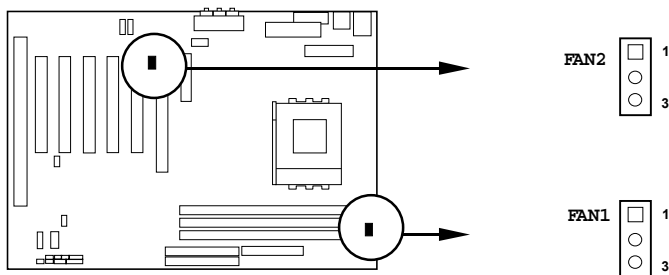

(11) IR infrared module Headers: (5-pin IR1)

This connector supports the optional wireless transmitting and receiving infrared module. You must configure the setting through the BIOS setup to use the IR function.

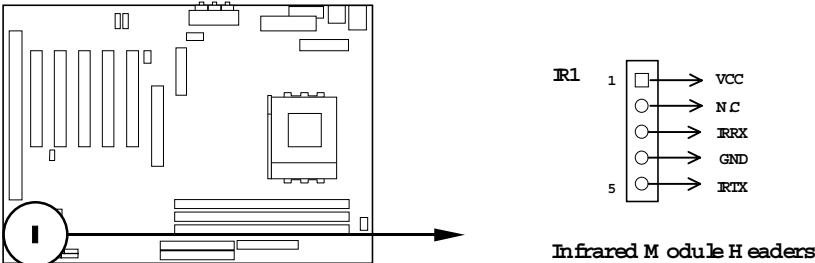

(12) CD Audio-In Headers: (4-pin CD_IN1, CD_IN2)

CD_IN1 and CD_IN2 are the connectors for CD-Audio Input signal. Please connect it to CD-ROM CD-Audio output connector.

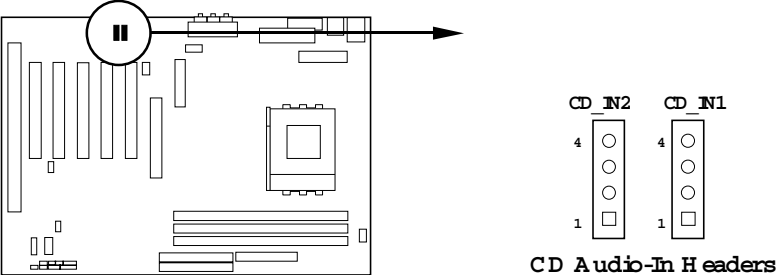

2-7 Starting Up Your Computer

1. After all connection are made, close your computer case cover.
2. Be sure all the switch are off, and check that the power supply input voltage is set to proper position, usually in-put voltage is 220V~240V or 110V~120V depending on your country's voltage used.
3. Connect the power supply cord into the power supply located on the back of your system case according to your system user's manual.
4. Turn on your peripheral as following order:
 - a. Your monitor.
 - b. Other external peripheral (Printer, Scanner, External Modem etc...)
 - c. Your system power. For ATX power supplies, you need to turn on the power supply and press the ATX power switch on the front side of the case.
5. The power LED on the front panel of the system case will light. The LED on the monitor may light up or switch between orange and green after the system is on. If it compolies with green standards or if it is has a power standby feature. The system will then run power-on test. While the test are running, the BIOS will alarm beeps or additional message will appear on the screen.

If you do not see any thing within 30 seconds from the time you turn on the power. The system may have failed on power-on test. Recheck your jumper settings and connections or call your retailer for assistance.

Beep	Meaning
One short beep when displaying logo	No error during POST
Long beeps in an endless loop	No DRAM install or detected
One long beep followed by three short beeps	Video card not found or video card memory bad
High frequency beeps when system is working	CPU overheated System running at a lower frequency

6. During power-on, press <Delete> key to enter BIOS setup. Follow the instructions in BIOS SETUP.
7. **Power off your computer:** You must first exit or shut down your operating system before switch off the power switch. For ATX power supply, you can press ATX power switching after exiting or shutting down your operating system. If you use Windows 9X, click "Start" button, click "Shut down" and then click "Shut down the computer?" The power supply should turn off after windows shut down.

Chapter 3

Introducing BIOS

The BIOS is a program located on a Flash Memory on the motherboard. This program is a bridge between motherboard and operating system. When you start the computer, the BIOS program gain control. The BIOS first operates an auto-diagnostic test called POST (power on self test) for all the necessary hardware, it detects the entire hardware device and configures the parameters of the hardware synchronization. Only when these tasks are completed done it gives up control of the computer to operating system (OS). Since the BIOS is the only channel for hardware and software to communicate, it is the key factor for system stability, and in ensuring that your system performance as its best.

In the BIOS Setup main menu of Figure 3-1, you can see several options. We will explain these options step by step in the following pages of this chapter, but let us first see a short description of the function keys you may use here:

- Press <Esc> to quit the BIOS Setup.
- Press ↑↓←→ (up, down, left, right) to choose, in the main menu, the option you want to confirm or to modify.
- Press <F10> when you have completed the setup of BIOS parameters to save these parameters and to exit the BIOS Setup menu.
- Press Page Up/Page Down or +/- keys when you want to modify the BIOS parameters for the active option.

3-1 Entering Setup

Power on the computer and by pressing immediately allows you to enter Setup.

If the message disappears before your respond and you still wish to enter Setup, restart the system to try again by turning it OFF then ON or pressing the “RESET” button on the system case. You may also restart by simultaneously pressing <Ctrl>, <Alt> and <Delete> keys. If you do not press the keys at the correct time and the system does not boot, an error message will be displayed and you will again be asked to

Press <F1> to continue, <Ctrl-Alt-Esc> or to enter Setup

3-2 Getting Help

Main Menu

The on-line description of the highlighted setup function is displayed at the bottom of the screen.

Status Page Setup Menu/Option Page Setup Menu

Press F1 to pop up a small help window that describes the appropriate keys to use and the possible selections for the highlighted item. To exit the Help Window, press <Esc>.

3-3 The Main Menu

Once you enter Award® BIOS CMOS Setup Utility, the Main Menu (Figure 3-1) will appear on the screen. The Main Menu allows you to select from fourteen setup functions and two exit choices. Use arrow keys to select among the items and press <Enter> to accept or enter the sub-menu.

CMOS Setup Utility – Copyright(C) 1984-2000 Award Software

Standard CMOS Features	Frequency/Voltage Control
Advanced BIOS Features	Load optimized Defaults
Advanced Chipset Features	Load Standard Defaults
Integrated Peripherals	Set Supervisor Password
Power Management Setup	Set User Password
PnP/PCI Configurations	Save & Exit Setup
PC Health Status	Exit Without Saving
Esc : Quit ↑ ↓ → ← : Select Item	
F10 : Save & Exit Setup	
Time, Date, Hard Disk Type...	

Figure 3-1

Standard CMOS Features

Use this Menu for basic system configurations.

Advanced BIOS Features

Use this menu to set the Advanced Features available on your system.

Advanced Chipset Features

Use this menu to change the values in the chipset registers and optimize your system's performance.

Integrated Peripherals

Use this menu to specify your settings for integrated peripherals.

Power Management Setup

Use this menu to specify your settings for power management.

PnP/PCI configurations

This entry appears if your system supports PnP/PCI.

PC Health Status

This entry shows your PC health status.

Frequency/Voltage Control

Use this menu to specify your settings for frequency/voltage control.

Load Optimized Defaults

Use this menu to load the BIOS default values that are factory settings for optimal performances system operations.

Load Standard Defaults

Use this menu to load the BIOS default values for the minimal/stable performance system operation.

Set Supervisor/User Password

Use this menu to set User and Supervisor Passwords.

Save & Exit Setup

Save CMOS value changes to CMOS and exit setup.

Exit Without Saving

Abandon all CMOS value changes and exit setup.

3-4 Standard CMOS Features

The items in Standard CMOS Setup Menu are divided into several categories. Each category includes no, one or more than one setup items. Use the arrow keys to highlight the item and then use the <PgUp> or <PgDn> keys to select the value you want in each item.

CMOS Setup Utility – Copyright(C) 1984-2000 Award Software

Standard CMOS Features

Date (mm:dd:yy)	Wed, Jul, 26 2000	Item Help
Time (hh:mm:ss)	17 : 35 : 22	
> IDE Primary Master	Press Enter None	Menu Level > Change the day, month, year and century
> IDE Primary Slave	Press Enter None	
> IDE Secondary Master	Press Enter None	
> IDE Secondary Slave	Press Enter None	
Drive A	1.44M, 3.25 in.	
Drive B	None	
Video	EGA/VGA	
Halt On	All,But Keyboard	
Base Memory	640K	
Extended Memory	56320K	
Total Memory	57344K	
↑ ↓ → ← Move Enter:Select Item +/-/PU/PD:Value F10:Save ESC:Exit F1:General Help F5:Previous Values F6:Optimized Defaults F7:Standard Defaults		

Date

The date format is <day><month><date><year>.

Day Day of the week, from Sun to Sat, determined by BIOS. Read-only.

Month The month from Jan. through Dec.

Date The date from 1 to 31 can be keyed by numeric function keys.

Year The year depends on the year of the BIOS.

Time

The time format is <hour><minute><second>.

Primary Master/Primary Slave

Secondary Master/Secondary Slave

Press PgUp/<+> or PgDn/<-> to select Manual, None, Auto type. Note that the specifications of your drive must match with the drive table. The hard disk will not work properly if you enter improper information for this category. If your hard disk drive type is not matched or listed, you can use Manual to define your own drive type manually.

If you select Manual, related information is asked to be entered to the following items. Enter the information directly from the keyboard. This information should be provided in the documentation from your hard disk vendor or the system manufacturer.

If the controller of HDD interface is SCSI, the selection shall be “None”.

If the controller of HDD interface is CD-ROM, the selection shall be “None”

Access Mode The settings are Auto Normal, Large, and LBA.

Cylinder number of cylinders

Head number of heads

Precomp write precomp

Landing Zone landing zone

Sector number of sectors

3-5 Advanced BIOS Features

CMOS Setup Utility – Copyright(C) 1984-2000 Award Software
Advanced BIOS Features

		Item Help
Anti-Virus Protection	Enabled	Menu Level > Allows you to choose The VIRUS warning Feature for IDE Hard Disk boot sector Protection. If this Function is enabled And someone attempt to Write data into this Area, BIOS will show a warning message on Screen and alarm beep
PhoneixNet Support	Disabled	
CPU Internal Cache	Enabled	
External Cache	Enabled	
CPU L2 Cache ECC Checking	Enabled	
Quick Power On Self Test	Enabled	
First Boot Device	Floppy	
Second Boot Device	HDD-0	
Third Boot Device	LS120	
Boot other Device	Enabled	
Swap Floppy Drive	Disabled	
Boot Up Floppy Seek	Enabled	
Boot Up NumLock Status	On	
Gate A20 Option	Normal	
Typematic Rate Setting	Disabled	
x Typematic Rate (Chars/Sec)	6	
x Typematic Delay (Msec)	250	
Security Option	Setup	
OS Select For DRAM > 64MB	Non-OS2	
HDD S.M.A.R.T. Capability	Disabled	
Video BIOS Shadow	Enabled	
C8000-CBFFF Shadow	Disabled	
CC000-CFFFF Shadow	Disabled	
D0000-D3FFF Shadow	Disabled	
D4000-D7FFF Shadow	Disabled	
D8000-DBFFF Shadow	Disabled	
DC000-DFFFF Shadow	Disabled	
↑ ↓ → ← Move Enter:Select Item +/-/PU/PD:Value F10:Save ESC:Exit F1:General Help F5:Previous Values F6:Optimized Defaults F7:Standard Defaults		

Anti-Virus Protection

Allows you to choose the VIRUS Warning feature for IDE Hard Disk boot sector protection. If this function is enabled and someone attempt to write data into this area, BIOS will show a warning message on screen and alarm beep.

Disabled (default) No warning message to appear when anything attempts to access the boot sector or hard disk partition table.

Enabled Activates automatically when the system boots up causing a warning message to appear when anything attempts to access the boot sector of hard disk partition table.

CPU Internal Cache

The default value is Enabled.

- Enabled** (default) Enable cache
- Disabled** Disable cache

Note: The internal cache is built in the processor.

External Cache

Choose Enabled or Disabled. This option enables the Level 2 cache memory.

CPU L2 Cache ECC Checking

Choose Enabled or Disabled. This option enables the Level 2 cache memory ECC (error check correction).

Processor Number Feature

This option is for Pentium® III processor. During Enabled, this will check the CPU Serial number. Disabled this option if you don't want the system to know the Serial number.

Quick Powr On Self-Test

This category speeds up Power On Self Test (POST) after you power on the computer. If this is set to Enabled. BIOS will shorten or skip some check items during POST.

- Enabled** (default) Enable quick POST
- Disabled** Normal POST

First/Second/Third/Fourth Boot Device

The BIOS attempts to load the operating system from the devices in the sequence selected in these items. The settings are Floppy, LS/ZIP, HDD-0/HDD-1/HDD-3, SCSI, CDROM, LAD and Disabled.

Swap Floppy Drive

Switches the floppy disk drives between being designated as A and B. Default is Disabled.

Boot Up Floppy Seek

During POST, BIOS will determine if the floppy disk drive installed is 40 or 80 tracks. 360K type is 40 tracks while 760K, 1.2M and 1.44M are all 80 tracks.

Boot Up NumLock Status

The default value is On.

- On** (default) Keypad is numeric keys.
- Off** Keypad is arrow keys.

Gate A20 Option

- Normal** The A20 signal is controlled by keyboard controller or chipset hardware.
- Fast** (default) The A20 signal is controlled by port 92 or chipset specific method.

Typematic Rate Setting

Keystrokes repeat at a rate determined by the keyboard controller. When enabled, the typematic rate and typematic delay can be selected. The settings are: Enabled/Disabled.

Typematic Rate (Chars/Sec)

Sets the number of times a second to repeat a keystroke when you hold the key down. The settings are: 6, 8, 10, 12, 15, 20, 24, and 30.

Typematic Delay (Msec)

Sets the delay time after the key is held down before it begins to repeat the keystroke. The settings are 250, 500, 750, and 1000.

Security Option

This category allows you to limit access to the system and Setup, or just to Setup.

- | | |
|------------------------|---|
| System | The system will not boot and access to Setup will be denied if the correct password is not entered at the prompt. |
| Setup (default) | The system will boot, but access to Setup will be denied if the correct password is not entered at the prompt. |

OS Select For DRAM > 64MB

Allows OS2[®] to be used with >64MB of DRAM. Settings are Non-OS/2 (default) and OS2. Set to OS/2 if using more than 64MB and running OS/2[®].

Report No FDD For Win 95

Whether report no FDD for Win 95 or not. The settings are: Yes, No.

3-6 Advanced Chipset Features

The Advanced Chipset Features Setup option is used to change the values of the chipset registers. These registers control most of the system options in the computer.

CMOS Setup Utility – Copyright(C) 1984-2000 Award Software

Advanced Chipset Features

> Advanced DRAM Control	Press Enter	Item Help
> Advanced AGP Control	Press Enter	
DRAM Clock	PC100 SDRAM	Menu Level >
Memory Hole	Disabled	
System BIOS Cacheable	Enabled	
Video RAM Cacheable	Enabled	
K7 CLK_CTL Select	Default	
Memory Parity/ECC Check	Disabled	
↑ ↓ → ← Move Enter:Select Item +/-/PU/PD:Value F10:Save ESC:Exit F1:General Help F5:Previous Values F6:Optimized Defaults F7:Standard Defaults		

Advanced DRAM Control

Please refer to section 3-6-1

Advanced AGP Control

Please refer to section 3-6-2

DRAM Clock

This field displays the capability of the memory modules that you can use

The choice is either PC100 or PC133.

Memory Hole

You can reserve this area of system memory for ISA adapter ROM. When this area is reserved, it cannot be cached. The user information of peripherals that need to use this area of system memory usually discusses their memory requirements. The settings are: Enabled and Disabled.

System BIOS Cacheable

Selecting Enabled allows caching of the system BIOS ROM at F0000h-FFFFFFh, resulting in better system performance. However, if any program writes to this memory area, a system error may result. The settings are: Enabled and Disabled.

Video RAM Cacheable

Select Enabled allows caching of the video BIOS, resulting in better system performance. However, if any program writes to this memory area, a system error may result. The settings are: Enabled and Disabled.

K7 CLK_CTL Select

This register contains values that tell the processor how to ramp up the processor ramp up the processor clock during low power modes.

The choice is either Default or Optimal.

Memory Parity

This function provides parity check of memory.

The choice is either Disabled or Enabled.

3-6-1 Advanced DRAM Control

CMOS Setup Utility – Copyright(C) 1984-2000 Award Software

Advanced DRAM Control

Auto Configuration	Optimized	Item Help
Precharge Command	3T	Menu Level >>
Active Command	5T	
Active to CMD Command	2T	
Write Recovery Time	2T	
SDRAM Cycle Length	By SPD	
Bank Interleave	By SPD	
DRAM Drive Strength	Auto	
x DRAM Drive Value	21	
PCI Master Pipeline Req	Disabled	
P2C/C2P Concurrency	Disabled	
Fast R-W Turn Around	Disabled	
CPU to PCI Post Write	Enabled	
PCI Dynamic Bursting	Disabled	
PCI Master 0 WS Write	Disabled	
PCI Delay Transaction	Enabled	
PCI#2 Access #1 Retry	Disabled	

↑ ↓ → ← Move Enter:Select Item +/-/PU/PD:Value F10:Save ESC:Exit F1:General Help
 F5:Previous Values F6:Optimized Defaults F7:Standard Defaults

Precharge Command

If an insufficient number of cycles is allowed for the RAS to accumulate its charge before DRAM refresh, the refresh may be incomplete and the DRAM may fail to retain data. *Fast* gives faster performance; and *Slow* gives more stable performance. This field applies only when synchronous DRAM is installed in the system. The settings are: 2 and 3.

Active Command

This field let's you insert a timing delay between the CAS and RAS strobe signals, used when DRAM is written to, read from, or refreshed. *Fast* gives faster performance; and *Slow* gives more stable performance. This field applies only when synchronous DRAM is installed in the system. The settings are: 2 and 3.

Active to CMD Command

Select the number of SCLKs for an access cycle. The settings are: 5/7 and 6/8.

SDRAM Cycle Length

When synchronous DRAM is installed, the number of clock cycles of CAS latency depends on the DRAM timing. The settings are: 2 and 3.

PCI Delay Transaction

The chipset has an embedded 32-bit posted write buffer to support delay transactions cycles. Select Enabled to support compliance with PCI specification version 2.1. The settings are: Enabled and Disabled.

3-6-2 Advanced AGP Control

CMOS Setup Utility – Copyright(C) 1984-2000 Award Software
Advanced AGP Control

AGP Fast Write	Enabled	Item Help
AGP Master 1 WS Write	Enabled	Menu Level >>
AGP Master 1 WS Read	Enabled	
AGP Aperture Size	64M	
AGP Rate Mode	Auto	
AGP Driving Control	Auto	
x AGP Driving Value	DA	
↑ ↓ → ← Move Enter:Select Item +/-/PU/PD:Value F10:Save ESC:Exit F1:General Help F5:Previous Values F6:Optimized Defaults F7:Standard Defaults		

Note: Change these settings only if you are familiar with the chipset.

3-7 Integrated Peripherals

CMOS Setup Utility – Copyright(C) 1984-2000 Award Software
Integrated Peripherals

> OnChip IDE Function	Press Enter	Item Help
> OnChip DEVICE Function	Press Enter	
> OnChip SUPERIO Function	Press Enter	
Init Display First	PCI Slot	Menu Level >
↑ ↓ → ← Move Enter:Select Item +/-/PU/PD:Value F10:Save ESC:Exit F1:General Help F5:Previous Values F6:Optimized Defaults F7:Standard Defaults		

OnChip IDE Function

Please refer to section 3-7-1

OnChip DEVICE Function

Please refer to section 3-7-2

OnChip SUPERIO Function

Please refer to section 3-7-3

Init Display First

This item allows you to decide to activate whether PCI Slot or AGP VGA first. The settings are: PCI Slot, AGP Slot.

3-7-1 OnChip IDE Function

CMOS Setup Utility – Copyright(C) 1984-2000 Award Software

OnChip IDE Function

OnChip IDE Channel0	Enabled	Item Help	
OnChip IDE Channel1	Enabled		
IDE 32bit Transfer Mode	Enabled	Menu Level >>	
Primary Master PIO	Auto		
Primary Slave PIO	Auto		
Secondary Master PIO	Auto		
Secondary Slave PIO	Auto		
Primary Master UDMA	Auto		
Primary Slave UDMA	Auto		
Secondary Master UDMA	Auto		
Secondary Slave UDMA	Auto		
IDE HDD Block Mode	Enabled		
IDE Prefetch Mode	Enabled		
↑ ↓ → ← Move Enter:Select Item +/-/PU/PD:Value F10:Save ESC:Exit F1:General Help F5:Previous Values F6:Optimized Defaults F7:Standard Defaults			

OnChip IDE Channal0/Channel1

The integrated peripheral controller contains an IDE interface with support for two IDE channels. Select *Enabled* to activate each channel separately. The settings are: Enabled and Disabled.

Primary/Secondary Master/Slave PIO

The four IDE PIO (Programmed Input/Output) fields let you set a PIO mode (0-4) for each of the four IDE devices that the onboard IDE interface supports. Modes 0 through 4 provide successively increased performance. In Auto mode, the system automatically determines the best mode for each device. The settings are: Auto, Mode 0, Mode 1, Mode 2, Mode 3, Mode 4.

Primary/Secondary Master/Slave UDMA

Ultra DMA/33 implementation is possible only if your IDE hard drive supports it and the operating environment includes a DMA driver (Windows 95 OSR2 or a third-party IDE bus master driver). If your hard drive and your system software both support Ultra DMA/33 and Ultra DMA/66, select Auto to enable BIOS support. The settings are: Auto, Disabled.

IDE HDD Block Mode

Block mode is also called block transfer, multiple commands, or multiple sector read/write. If your IDE hard drive supports block mode (most new drives do), select Enabled for automatic detection of the optimal number of block read/writes per sector the drive can support. The settings are: Enabled, Disabled.

3-7-2 OnChip DEVICE Function

CMOS Setup Utility – Copyright(C) 1984-2000 Award Software

OnChip DEVICE Function

OnChip USB	Enabled	Item Help
USB Keyboard Support	Disabled	
OnChip AUDIO Function	Press Enter	Menu Level >>
AMR Modem DEVICE	Auto	
↑ ↓ → ← Move Enter:Select Item +/-/PU/PD:Value F10:Save ESC:Exit F1:General Help F5:Previous Values F6:Optimized Defaults F7:Standard Defaults		

OnChip USB

Select *Enabled* if your system contains a Universal Serial Bus (USB) controller and you have a USB peripherals. The settings are: Enabled, Disabled.

USB Keyboard Support

Select *Enabled* if your system contains a Universal Serial Bus (USB) controller and you have a USB keyboard. The settings are: Enabled, Disabled.

OnChip AUDIO Function

Please refer to section 3-7-2.1

AMR Modem DEVICE

This item allows you to decide to enable/disable the KT-133 chipset family to support AC97 Modem. The settings are: Auto, Disabled.

3-7-2.1 OnChip AUDIO Function

CMOS Setup Utility – Copyright(C) 1984-2000 Award Software

OnChip AUDIO Function

AC97 Sound Device	Enabled	Item Help
Sound Blaster	Disabled	
SB I/O Base Address	220H	Menu Level >>>
SB IRQ Select	IRQ 5	
SB DMA Select	DMA 1	
MPU-401	Disabled	
MPU-401 I/O Address	330-333H	
Game Port (200-207H)	Enabled	
↑ ↓ → ← Move Enter:Select Item +/-/PU/PD:Value F10:Save ESC:Exit F1:General Help		
F5:Previous Values F6:Optimized Defaults F7:Standard Defaults		

AC97 Sound Device

This item allows you to decide to enable/disable the KT-133 chipset family to support AC97 Audio. The settings are: Enabled, Disabled.

Game Port Address/Midi Port Address

This will determine which Address the Game Port/Midi Port will use.

3-7-3 OnChip SUPERIO Function

CMOS Setup Utility – Copyright(C) 1984-2000 Award Software
OnChip SUPERIO Function

Onboard FDD Controller Enabled Onboard Serial Port 1 Auto Onboard Serial Port 2 Auto UART 2 Mode Standard x IR Function Duplex Half x TX,RX inverting enable No, Yes Onboard Parallel Port 378/IRQ7 Onboard Parallel Mode Normal ECP Mode Use DMA 3 Parallel Port EPP Type EPP1.9	Item Help Menu Level >>
↑ ↓ → ← Move Enter:Select Item +/-/PU/PD:Value F10:Save ESC:Exit F1:General Help F5:Previous Values F6:Optimized Defaults F7:Standard Defaults	

Onboard FDD Controller

Select Enabled if your system has a floppy disk controller (FDD) installed on the system board and you wish to use it. If you install add-on FDC or the system has no floppy drive, select Disabled in this field. The settings are: Enabled and Disabled.

Onboard Serial Port 1/Port 2

Select an address and corresponding interrupt for the first and the second serial ports. The settings are: 3F8/IRQ4, 2E8/IRQ3, 3E8/IRQ4, 2F8/IRQ3, Disabled, Auto.

UART 2 Mode

This item allows you to determine which InfraRed(IR) function of the onboard I/O chip, this functions uses.

Onboard Parallel Port

There is a built-in parallel port on the on-board Super I/O chipset that Provides Standard, ECP, and EPP features. It has the following option:

Disabled

(3BCH/IRQ7)/ Line Printer port 0

(278H/IRQ5)/ Line Printer port 2

(378H/IRQ7) Line Printer port 1

Onboard Parallel Mode

SPP : Standard Parallel Port

EPP : Enhanced Parallel Port

ECP : Extended Capability Port

SPP/EPP/ECP/ECP+EPP

To operate the onboard parallel port as Standard Parallel Port only, choose “SPP.” To operate the onboard parallel port in the EPP modes simultaneously, choose “EPP.” By choosing “ECP”, the onboard parallel port will operate in ECP mode only. Choosing “ECP+EPP” will allow the onboard parallel port to support both the ECP and EPP modes simultaneously. The ECP mode has to use the DMA channel, so choose the onboard parallel port with the ECP feature. After selecting it, the following message will appear: “ECP Mode Use DMA” at this time, the user can choose between DMA channels 3 to 1. The onboard parallel port is EPP Spec. compliant, so after the user chooses the onboard parallel port with the EPP function, the following message will be displayed on the screen: “EPP Mode Select.” At this time either EPP 1.7 spec. or EPP 1.9 spec. can be chosen.

3-8 Power Management Setup

The Power Management Setup allows you to configure your system to most effectively save energy saving while operating in a manner consistent with your own style of computer use.

CMOS Setup Utility – Copyright(C) 1984-2000 Award Software

Power Management Setup

ACPI Function Enabled > Power Management Press Enter PM Control by APM Yes Video Off Option Suspend -> off Video off Method V/H SYNC+Blank MODEM Use IRQ 3 Soft-off by PWRBTN Instant-off State After Power Failure Auto > Wake-Up Events Press Enter	Item Help Menu Level >
↑ ↓ → ← Move Enter:Select Item +/-/PU/PD:Value F10:Save ESC:Exit F1:General Help F5:Previous Values F6:Optimized Defaults F7:Standard Defaults	

ACPI Function

This item allows you to Enabled/Disabled the Advanced Configuration and Power Management (ACPI). The settings are Enabled and Disabled.

Power Management

Please refer to section 3-8-1

Video Off Option

This determines the manner in which the monitor is blanked. The choice are Suspend → off, All Modes → Off, and Always On.

Video Off Method

This determines the manner in which the monitor is blanked.

- DPMS (default)** Initial display power management signaling.
- Blank Screen** This option only writes blanks to the video buffer.
- V/H SYNC+Blank** This selection will cause the system to turn off the vertical and horizontal synchronization ports and write blanks to the video buffer.

Modem Use IRQ

This determines the IRQ in which the MODEM can use.

The settings are: 3, 4, 5, 7, 9, 10, 11, NA.

Soft-off by PWRBTN

Pressing the power button for more than 4 seconds forces the system to enter the Soft-Off state. The settings are: Delay 4 Sec, Instant-Off.

Wake-Up Events

Please refer to section 3-8-2

3-8-1 Power Management

CMOS Setup Utility – Copyright(C) 1984-2000 Award Software

Power Management

Power Management	User Define	Item Help
HDD Power Down	Disable	Menu Level >>
Doze Mode	Disable	
Suspend Mode	Disable	
↑ ↓ → ← Move Enter:Select Item +/-/PU/PD:Value F10:Save ESC:Exit F1:General Help F5:Previous Values F6:Optimized Defaults F7:Standard Defaults		

Power Management

This category allows you to select the type (or degree) of power saving which is directly related to the following modes:

User Define(default) Allows you to set each mode individually. When not disabled, each of the ranges is from 1 min. to 1hr. except for HDD Power Down that ranges from 1 min. to 15 min. and disable.

Min Saving Minimum power management. Doze Mode 1H, Suspend Mode=1 hr., Power Down=15 min.

Max Saving Maximum power management. Doze Mode 1H, Suspend Mode=1 min., Power Down=1 min.

HDD Power Down

When enabled and after setting time of system inactivity, the hard disk drive will be powered down while all the other devices remain active.

The settings are: 1/2/3/4/5/6/7/8/9/10/11/12/13/14/15 Min and Disabled.

Suspend Mode

When enabled and after the set time of system inactivity, all devices except the CPU will be shut off.

The settings are: 1/2/4/8/12/20/30/40 Min, 1 Hour, and Disabled.

3-8-2 Wake up Events

CMOS Setup Utility – Copyright(C) 1984-2000 Award Software

Wake Up Events

VGA	OFF	Item Help Menu Level >>
LPT & COM	LPT/COM	
HDD & FDD	ON	
PCI Master	OFF	
PowerOn by PCI Card	Disabled	
Wake Up On LAN/Ring	Disabled	
RTC Alarm Resume	Disabled	
x Date (of Month)	0	
x Resume Time (hh:mm:ss)	0 : 0 : 0	
Primary INTR	ON	
> IRQs Activity Monitoring	Press Enter	
↑ ↓ → ← Move Enter:Select Item +/-/PU/PD:Value F10:Save ESC:Exit F1:General Help F5:Previous Values F6:Optimized Defaults F7:Standard Defaults		

PowerOn by PCI card

This will enable the system to wake up to PCI Lan Card.

The settings are: Enabled and Disabled.

Wake Up On LAN/Ring

During Disabled, the system will ignore any incoming call from the modem. During Enabled, the system will boot up if there's an incoming call from the modem.

RTC Alarm Resume

This function is for setting date and time for your computer to boot up. During Disabled, you cannot use this function. During Enabled, choose the Date and Time Alarm:

Date(of month) Alarm

You can choose which month the system will boot up. Set to 0, to boot every day.

Time(hh:mm:ss) Alarm

You can choose what hour, minute and second the system will boot up.

Note: If you have change the setting, you must let the system boot up until it goes to the operating system, before this function will work.

IRQs Activity Monitoring

Please refer to section 3-8-2.1

3-8-2.1 IRQs Activity Monitoring

CMOS Setup Utility – Copyright(C) 1984-2000 Award Software

IRQs Activity Monitoring

IRQ3 (COM 2)	Enabled	Item Help
IRQ4 (COM 1)	Enabled	Menu Level >>>
IRQ5 (LPT 2)	Enabled	
IRQ6 (Floppy Disk)	Enabled	
IRQ7 (LPT 1)	Enabled	
IRQ8 (RTC Alarm)	Disabled	
IRQ9 (IRQ2 Redir)	Disabled	
IRQ10 (Reserved)	Disabled	
IRQ11 (Reserved)	Disabled	
IRQ12 (PS/2 Mouse)	Enabled	
IRQ13 (Coprocessor)	Disabled	
IRQ14 (Hard Disk)	Enabled	
IRQ15 (Reserved)	Disabled	
↑ ↓ → ← Move Enter:Select Item +/-/PU/PD:Value F10:Save ESC:Exit F1:General Help		
F5:Previous Values F6:Optimized Defaults F7:Standard Defaults		

3-9 PnP/PCI Configuration Setup

This section describes configuring the PCI bus system. PCI, or Personal Computer Interconnect, is a system which allows I/O devices to operate at speeds nearing the speed the CPU itself uses when communicating with its own special components. This section covers some very technical items and it is strongly recommended that only experienced users should make any changes to the default settings.

CMOS Setup Utility – Copyright(C) 1984-2000 Award Software

PnP/PCI Configurations

PnP OS Installed	No	Item Help
Reset Configuration Data	Disabled	
Resources Controlled By	Auto(ESCD)	Menu Level > Select Yes if you are Using a Plug and Play Capable operating System Select No if You need the BIOS to Configure non-boot devices
x IRQ Resources	Press Enter	
x DMA Resources	Press Enter	
PCI/VGA Palette Snoop	Disabled	
Assign IRQ For VGA	Enabled	
Assign IRQ For USB	Enabled	
↑ ↓ → ← Move Enter:Select Item +/-/PU/PD:Value F10:Save ESC:Exit F1:General Help F5:Previous Values F6:Optimized Defaults F7:Standard Defaults		

Reset Configuration Data

Normally, you leave this field Disabled. Select Enabled to reset Extended System Configuration Data (ESCD) when you exit Setup if you have installed a new add-on and the system reconfiguration has caused such a serious conflict that the operating system can not boot. The settings are: Enabled and Disabled.

Resource Controlled By

The Award Plug and Play BIOS has the capacity to automatically configure all of the boot and Plug and Play compatible devices. However, this capability means absolutely nothing unless you are using a Plug and Play operating system such as Windows®95/98. If you set this field to “manual” choose specific resources by going into each of the sub menu that follows this field (a sub menu is preceded by a “>”).

The settings are: Auto(ESCD), Manual.

IRQ Resources

When resources are controlled manually, assign each system interrupt a type, depending on the type of device using the interrupt.

DMA Resources

This sub menu can let you control the DMA resource.

PCI/VGA Palette Snoop

Leave this field at *Disabled*. The settings are Enabled, Disabled.

3-10 PC Health Status

This section shows the Status of you CPU, Fan, Warning for overall system status. This is only available if there is Hardware Monitor onboard.

CMOS Setup Utility – Copyright(C) 1984-2000 Award Software

PC Health Status

Show PC Health in Post	Enabled	Item Help
Current CPU Temp.	50°C	
Current System Temp.	25°C	Menu Level >
Current CPUFAN1 Speed	5000 rpm	
Current CPUFAN2 Speed	5000 rpm	
Vcore	1.81V	
Vdd	3.45V	
3.3V	3.35V	
5V	5.10V	
12V	12.40V	
CPU protect for CPU Fan off	Enabled	
↑ ↓ → ← Move Enter:Select Item +/-/PU/PD:Value F10:Save ESC:Exit F1:General Help F5:Previous Values F6:Optimized Defaults F7:Standard Defaults		

Show PC Health in Post

During Enabled, it displays information list below. The choice is either Enabled or Disabled

Current CPU Temperature/Current System Temp/Current FAN1, FAN2 Speed/Vcore/Vdd/3.3V/+5V/+12V (V)

This will show the CPU/FAN/System voltage chart and FAN Speed.

CPU protect for CPUFan off

During Enabled, system will warn the user if CPU Fan is not functioning.

3-11 Frequency/Voltage Control

This section is for setting CPU Frequency Control.

CMOS Setup Utility – Copyright(C) 1984-2000 Award Software
Frequency/Voltage Control

<table style="width: 100%; border-collapse: collapse;"> <tr> <td style="padding: 2px;">Auto Detect DIMM/PCI Clk</td> <td style="padding: 2px;">Enabled</td> </tr> <tr> <td style="padding: 2px;">CPU Host/PCI Spread Spec.</td> <td style="padding: 2px;">Default</td> </tr> <tr> <td style="padding: 2px;">CPU Vcore Select</td> <td style="padding: 2px;">Default</td> </tr> </table>	Auto Detect DIMM/PCI Clk	Enabled	CPU Host/PCI Spread Spec.	Default	CPU Vcore Select	Default	<table style="width: 100%; border-collapse: collapse;"> <tr> <td style="padding: 2px;">Item Help</td> </tr> <tr> <td style="padding: 2px; height: 100px;">Menu Level ></td> </tr> </table>	Item Help	Menu Level >
Auto Detect DIMM/PCI Clk	Enabled								
CPU Host/PCI Spread Spec.	Default								
CPU Vcore Select	Default								
Item Help									
Menu Level >									
<p>↑ ↓ → ← Move Enter:Select Item +/-/PU/PD:Value F10:Save ESC:Exit F1:General Help F5:Previous Values F6:Optimized Defaults F7:Standard Defaults</p>									

Auto Detect DIMM/PCI Clk

This item allows you to enable/disable auto detect DIMM/PCI Clock.

The settings are: Enabled, Disabled.

CPU Host/PCI Spread Spec.

This item allows you to set the CPU Host/PCI clock and Spread Spectrum.

The choice are: Default, 100/33Mhz/-0.5%, 100/33Mhz/±0.25%, 100/33Mhz/±0.5%
102/34Mhz/Off, 104/35Mhz/Off, 106/35Mhz/Off, 107/36Mhz/Off
108/36Mhz/Off, 109/36Mhz/Off, 110/37Mhz/Off, 111/37Mhz/Off
112/37Mhz/Off, 133/33Mhz/-0.5%, 133/33Mhz/±0.25%,
133/33Mhz/±0.5%

CPU Vcore Select

This item allows you to select Vcore of the CPU. The choice are: Default, -0.025V, +0.025V, +0.05V, +0.075V, +0.1V, +0.125V, +0.15V. Max. Vcore is 1.9V.

3-12 Load Standard/Optimized Defaults

Load Standard Defaults

When you press <Enter> on this item, you get confirmation dialog box with a message similar to:

Load Standard Defaults (Y/N)? N

Pressing <Y> loads the BIOS default values for the most stable, minimal-performance system operations.

Load Optimized Defaults

When you press <Enter> on this item, you get a confirmation dialog box with a message similar to:

Load Optimized Defaults (Y/N)? N

Pressing <Y> loads the default values that are factory settings for optimal performance system operations.

3-13 Set Supervisor/User Password

You can set either supervisor or user password, or both of them. The differences are:

Supervisor password: Can enter and change the options of the setup menus.

User password: Can only enter but do not have the right to change the options of the setup menus. When you select this function, the following message will appear at the center of the screen to assist you in creating a password.

ENTER PASSWORD:

Type the password, up to eight characters in length, and press <Enter>. The password typed now will clear any previously entered password from CMOS memory. You will be asked to confirm the password. Type the password again and press <Enter>. You may also press <Esc> to abort the selection and not enter a password.

To disable a password, just press <Enter> when you are prompted to enter the password. A message will confirm that the password will be disabled. Once the password is disabled, the system will boot and you can enter Setup freely.

PASSWORD DISABLED.

When a password has been enabled, you will be prompted to enter it every time you try to enter Setup. This prevents an unauthorized person from changing any part of your system configuration.

Additionally, when a password is enabled, you can also require the BIOS to request a password every time your system is rebooted. This would prevent unauthorized use of your computer.

You determine when the password is required within the BIOS Features Setup Menu and its Security option. If the Security option is set to “System”, the password will be required both at boot and at entry to Setup. If set to “Setup”, prompting only occurs when trying to enter Setup.