

**AX4SG**  
**AX4SG-N**  
**AX4SG-L**  
**Online Manual**







DOC. NO.: AX4SGL-OL-E0304B







## **What's in this manual**

<b>AX4SG / AX4SG-N / AX4SG-L .....</b>	<b>错误！未定义书签。</b>
<i>What's in this manual .....</i>	<i>2</i>
<i>You Must Notice .....</i>	<i>8</i>
<i>Before You Start .....</i>	<i>9</i>
<i>Overview .....</i>	<i>10</i>
<i>Feature Highlight .....</i>	<i>11</i>
<i>Quick Installation Procedure .....</i>	<i>16</i>
<i>Motherboard Map .....</i>	<i>17</i>
<i>Block Diagram .....</i>	<i>18</i>
<b>Hardware Installation .....</b>	<b>19</b>
<i>About "Manufacturer Upgrade Optional" and "User Upgrade Optional" .....</i>	<i>20</i>
<i>JP14 Clear CMOS Data .....</i>	<i>21</i>
<i>CPU Installation .....</i>	<i>22</i>
<i>CPU Over-current Protection .....</i>	<i>26</i>
<i>AOpen "Watch Dog ABS" .....</i>	<i>28</i>
<i>CPU Core Voltage Auto Detectable .....</i>	<i>29</i>
<i>CPU and System Fan Connector (with H/W Monitoring) .....</i>	<i>31</i>



	<i>JP28 Keyboard/Mouse Wake-up Enable/Disable Jumper</i> .....	32
	<i>DIMM Sockets</i> .....	33
	<i>Front Panel Connector</i> .....	35
	<i>ATX Power Connector</i> .....	36
	<i>AC Power Auto Recovery</i> .....	37
	<i>STBY LED and BOOT LED</i> .....	38
	<i>IDE and Floppy Connector</i> .....	39
	<i>Serial ATA Supported (with RAID function, RAID for AX4SG-L only)</i> .....	41
	<i>IrDA Connector</i> .....	49
	<i>S/PDIF (Sony/Philips Digital Interface) Connector</i> .....	50
	<i>Super 5.1 Channel Audio Effect</i> .....	51
	<i>AGP (Accelerated Graphic Port) 8X Expansion Slot</i> .....	52
	<i>AGP Protection Technology and AGP LED</i> .....	53
	<i>WOL (Wake on LAN)</i> .....	54
	<i>Color Coded Back Panel</i> .....	56
	<i>Support 10/100/1000 Mbps LAN onboard (for AX4SG-N and AX4SG-L)</i> .....	57
	<i>Support Eight USB2.0 Connectors</i> .....	58
	<i>COM2 Connector</i> .....	59
	<i>Game Port Bracket Supported</i> .....	60

	<i>Chassis Intrusion Connector</i> .....	61
	<i>CD Audio Connector</i> .....	62
	<i>AUX-IN Connector</i> .....	63
	<i>Front Audio Connector</i> .....	64
	<i>Dr. LED Connector</i> .....	65
	<i>AOConfig Utility</i> .....	67
	<i>Resetable Fuse</i> .....	69
	<i>3300µF Low ESR Capacitor</i> .....	70
	<i>Enlarged Aluminum Heatsink</i> .....	72
	<i>Open JukeBox Player</i> .....	73
	<i>Vivid BIOS technology</i> .....	77
	<i>The noise is gone!! --- SilentTek</i> .....	78
	<i>EzClock</i> .....	81
	<i>Hyper Threading Technology</i> .....	85
	<b>Driver and Utility .....</b>	<b>87</b>
	<i>Auto-run Menu from Bonus CD Disc</i> .....	87
	<i>Installing Intel® Chipset Software Installation Utility</i> .....	88
	<i>Intel Brookdale-G VGA driver</i> .....	89
	<i>Installing Intel IAA Driver RAID Edition</i> .....	90



*Installing Onboard Sound Driver* ..... 91

*Installing USB 2.0 Driver* ..... 92

*Installing LAN Driver (for AX4SG-N)*..... 96

*Installing LAN Driver (for AX4SG-L)* ..... 99

**PHOENIX-AWARD BIOS..... 102**

*How To Use Phoenix-Award™ BIOS Setup Program*..... 103

*How To Enter BIOS Setup* ..... 104

 *BIOS Upgrade under Windows environment* ..... 105

 *WinBIOS Utility* ..... 107

**Glossary ..... 109**

*AC97 CODEC* ..... 109

*ACPI (Advanced Configuration & Power Interface)* ..... 109

*ACR (Advanced Communication Riser)*..... 109

*AGP (Accelerated Graphic Port)*..... 110

*AMR (Audio/Modem Riser)*..... 110

*ATA (AT Attachment)* ..... 110

*BIOS (Basic Input/Output System)* ..... 111

*Bluetooth*..... 111

*CNR (Communication and Networking Riser)*..... 111



<i>DDR (Double Data Rate) RAM</i> .....	112
<i>ECC (Error Checking and Correction)</i> .....	112
<i>EEPROM (Electronic Erasable Programmable ROM)</i> .....	112
<i>EPROM (Erasable Programmable ROM)</i> .....	112
<i>EV6 Bus</i> .....	113
<i>FCC DoC (Declaration of Conformity)</i> .....	113
<i>FC-PGA (Flip Chip-Pin Grid Array)</i> .....	113
<i>FC-PGA2 (Flip Chip-Pin Grid Array)</i> .....	113
<i>Flash ROM</i> .....	113
<i>Hyper Threading</i> .....	114
<i>IEEE 1394</i> .....	114
<i>Parity Bit</i> .....	114
<i>PCI (Peripheral Component Interface) Bus</i> .....	115
<i>PDF Format</i> .....	115
<i>PnP (Plug and Play)</i> .....	115
<i>POST (Power-On Self Test)</i> .....	115
<i>PSB (Processor System Bus) Clock</i> .....	115
<i>RDRAM (Rambus Dynamic Random Access Memory)</i> .....	116
<i>RIMM (Rambus Inline Memory Module)</i> .....	116

SDRAM (Synchronous DRAM) ..... 116

SATA (Serial ATA) ..... 116

SMBus (System Management Bus) ..... 117

SPD (Serial Presence Detect) ..... 117

USB 2.0 (Universal Serial Bus) ..... 117

VCM (Virtual Channel Memory) ..... 117

Wireless LAN – 802.11b ..... 118

ZIP file ..... 118

**Troubleshooting..... 119**

**Technical Support ..... 123**

**Product Registration ..... 126**

**How to Contact Us ..... 错误！未定义书签。**



## **You Must Notice**

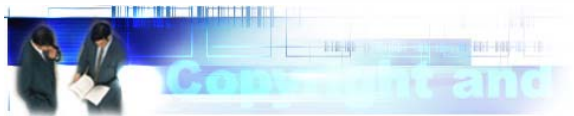

Adobe, the Adobe logo, Acrobat is trademarks of Adobe Systems Incorporated.

AMD, the AMD logo, Athlon and Duron are trademarks of Advanced Micro Devices, Inc.

Intel, the Intel logo, Intel Celeron, Pentium II, Pentium III, Pentium 4 are trademarks of Intel Corporation.

Microsoft, Windows, and Windows logo are either registered trademarks or trademarks of Microsoft Corporation in the United States and/or other countries.

All product and brand names used on this manual are used for identification purposes only and may be the registered trademarks of their respective owners.

All of the specifications and information contained in this manual are subject to change without notice. AOpen reserves the right to revise this publication and to make reasonable changes. AOpen assumes no responsibility for any errors or inaccuracies that may appear in this manual, including the products and software described in it.

**This documentation is protected by copyright law. All rights are reserved.**

**No part of this document may be used or reproduced in any form or by any means, or stored in a database or retrieval system without prior written permission from AOpen Corporation.**

**Copyright© 1996-2003, AOpen Inc. All Rights Reserved.**



## **Before You Start**



This Online Manual will introduce to the user how this product is installed. All useful information will be described in later chapters. Please keep this manual carefully for future upgrades or system configuration changes. This Online Manual is saved in [PDF format](#), we recommend using Adobe Acrobat Reader 5.0 for online viewing, it is included in Bonus CD disc or you can get free download from [Adobe web site](#).

Although this Online Manual is optimized for screen viewing, it is still capable for hardcopy printing, you can print it by A4 paper size and set 2 pages per A4 sheet on your printer. To do so, choose **File > Page Setup** and follow the instruction of your printer driver.

Thanks for the help of saving our earth.

## Overview

Thank you for choosing AOpen AX4SG / AX4SG-N / AX4SG-L motherboard. The AX4SG / AX4SG-N / AX4SG-L is Intel® Socket 478 motherboard (M/B) based on the ATX form factor featuring the [Intel® Springdale-G chipset](#). As high performance chipset built in the M/B, the AX4SG / AX4SG-N / AX4SG-L motherboard can support Intel® Socket 478 Pentium® 4 and 400/533/800 MHz [Front Side Bus \(FSB\)](#) clock. In the AGP performance, it has one AGP slot and supports AGP 8X/4X mode and pipelined spilt-transaction long burst transfer up to 2112MB/sec. According to different customer's requirements, the Intel Springdale-G chipset memory interface supports DDR400/333/266 SDRAM devices with densities of 64,128, 256, 512,1024Mb DDR RAM DIMM modules and the maximum memory size can be up to 4 GB. The onboard IDE controller supports Ultra DMA 33/66/100 mode, [Serial ATA](#) 150 Mbps and there are 6 PCI slots provided on this board. For AX4SG-L, On the strength of Broadcom BCM5705 controller on board, which is a highly-integrated Platform LAN Connect device, it provides 10/100/1000M bps Ethernet for office and home use. For AX4SG-N, it integrates Broadcom BCM4401 controller on board, and it provides 10/100M bps Ethernet. Besides, the AX4SG / AX4SG-N / AX4SG-L has an [AC97 CODEC](#) chipset onboard, providing high performance and magic surround stereo sound to let people enjoy working with it. More than that, this motherboard supports [USB 2.0](#) function with a fancy speed of up to 480Mbps. Now, let's enjoy all features from AOpen AX4SG / AX4SG-N / AX4SG-L motherboard.

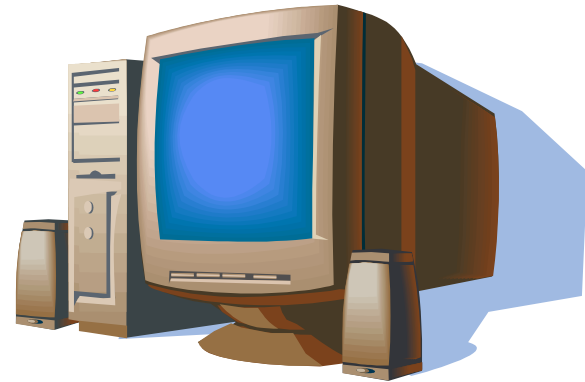

## Feature Highlight

### CPU

Supports Intel® Socket 478 Pentium® 4 1.6GHz~3.06 GHz+ with 400/533/800 MHz [Front Side Bus \(FSB\)](#) designed for Socket 478 technology.

### Chipset

Springdale-G is a Graphics Memory Controller Hub (GMCH) designed for use with the Pentium 4 processor with 512-KB L2 cache on 0.13 micron processor. It provides CPU, DDR, AGP, Hub, CSA Interfaces and integrated graphics with display interfaces. The CPU interface supports Pentium 4 processor subset of the Extended Mode of the Scalable Bus Protocol. The GMCH memory interface supports one up to two channels of DDR, and the AGP interface supports 0.8V/1.5V signaling with 8X/4X data transfers and 8X/4X AGP Fast Writes. The integrated graphics controller provides 3D, 2D, and display capabilities while using a portion of system memory for graphics memory (UMA) to provide a cost effective, high performance graphics solution. The Springdale-G platform supports the fifth generation I/O Controller Hub (ICH5 and ICH5R).

The ICH5 integrates an Ultra ATA 100 controller, two Serial ATA host controllers, one EHCI host controller and four UHCI host controllers supporting eight external USB2.0 ports, LPC interface controller; flash BIOS interface controller, PCI interface controller, AC'97 digital controller, integrated LAN controller, an ASF controller and a hub interface for communication with the Springdale-G GMCH. The ICH5R offers the same feature as ICH5 and adds support for RAID 0.

## Expansion Slots

Including six 32-bit/33MHz PCI and one AGP 8X/4X slots. The [PCI](#) local bus throughput can be up to 132MB/s. For AX4SG-N and AX4SG-L, of six PCI slots provided, five of them are master PCI slots with arbitration and decoding for all integrated functions and LPC bus, and PCI 1 supports slave mode PCI card only. For AX4SG, all six PCI slots are master PCI slots. AX4SG / AX4SG-N / AX4SG-L motherboard includes one AGP expansion slot for a bus mastering AGP graphic card. The [Accelerated Graphics Port \(AGP\)](#) specification provides a new level of video display sophistication and speed. The AGP video cards support data transfer rate up to 2112MB/s.

## Memory

With Springdale-G chipset, this motherboard can support dual channel [Double-Data-Rate \(DDR\) RAM](#). The dual channel mode allows chipsets to get data in 128 bit and zero wait state bursting between the RAM, The data transfers at 266/333/400MHz. The four slots of DDR RAM can be composed of an arbitrary mixture of 64, 128, 256, 512 MB or 1GB DDR RAM and maximum up to 4GB.

## LAN Port

For AX4SG-L, On the strength of Broadcom BCM5705 on board, which is a highly-integrated Platform LAN Connect device, it provides 10/100/1000 Mbps Ethernet for office and home use. For AX4SG-N, there is a Broadcom BCM4401 controller on board, and it can provide 10/100 Mbps Ethernet.

### **Ultra DMA 33/66/100 Bus Master IDE**

Comes with an on-board PCI Bus Master IDE controller with two connectors that support four IDE devices in two channels, supports Ultra DMA 33/66/100, PIO Modes 3 and 4 and Bus Master IDE DMA Mode 5, and supports Enhanced IDE devices.

### **Serial ATA**

Integrated in ICH5 that contains independent DMA operation on two ports. The SATA controllers are completely software transparent with the IDE interface, while providing a lower pin count and higher performance. The ICH5 SATA interface supports data transfer rates up to 150MB/s. Because AX4SG-L has ICH5R on board, it supports RAID 0 when using SATA HDD.

### **On-board AC'97 Sound**

AX4SG / AX4SG-N / AX4SG-L uses the [AC97](#) sound chip. This on-board audio includes a complete audio recording and playback system.

### **1MHz Stepping Frequency Adjustment**

Provides "1MHz Stepping Frequency Adjustment" function in the BIOS. This magic function allows you adjust [FSB](#) frequency from 100~400 by 1MHz stepping adjustment, and lets your system can get maximum performance.

### **Watch Dog ABS**

Includes AOpen "Watch Dog ABS" functions that can auto-reset default settings in 4.8 seconds when you fail to system overclocking.

## **S/PDIF Connectors**

S/PDIF (Sony/Philips Digital Interface) is a newest audio transfer format, which provides impressive quality through optical fiber and allows you to enjoy digital audio instead of analog audio.

## **Eight USB 2.0 Ports**

Provides six ports on the back panel and one [USB](#) 2.0 connector on the board, providing a total of eight USB 2.0 interface to connect devices such as mouse, keyboard, modem, scanner, etc.

## **Dr. LED (User Upgrade Optional)**

The Dr. LED has 8 LEDs on this AX4SG / AX4SG-N / AX4SG-L M/B to easily show what kind of problems you may encounter.

## **Power Management/Plug and Play**

Supports the power management function that conforms to the power-saving standards of the U.S. Environmental Protection Agency (EPA) Energy Star program. It also offers [Plug-and-Play](#), which helps save users from configuration problems, thus making the system much user-friendlier.

## **Hardware Monitoring Management**

Supports CPU or system fans status, temperature and voltage monitoring and alert, through the on-board hardware monitor module.

### Enhanced ACPI

Fully implement the [ACPI](#) standard for Windows® 98/ME/2000/XP series compatibility, and supports Soft-Off, STR (Suspend to RAM, S3), STD (Suspend to Disk, S4) features.

### Super Multi-I/O

Provides two high-speed UART compatible serial ports and one parallel port with EPP and ECP capabilities. UART can also be directed from COM1 to the Infrared Module for the wireless connections.

## **Quick Installation Procedure**

This page gives you a quick procedure on how to install your system. Follow each step accordingly.

1. Installing [CPU](#) and [Fan](#)
2. [Installing System Memory \(DIMM\)](#)
3. [Connecting Front Panel Cable](#)
4. [Connecting IDE and Floppy Cable](#)
5. [Connecting ATX Power Cable](#)
6. [Connecting Back Panel Cable](#)
7. [Power-on and Load BIOS Setup Default](#)
8. [Setting CPU Frequency](#)
9. Reboot
10. Installing Operating System (such as Windows 98)
11. [Installing Driver and Utility](#)



## Motherboard Map

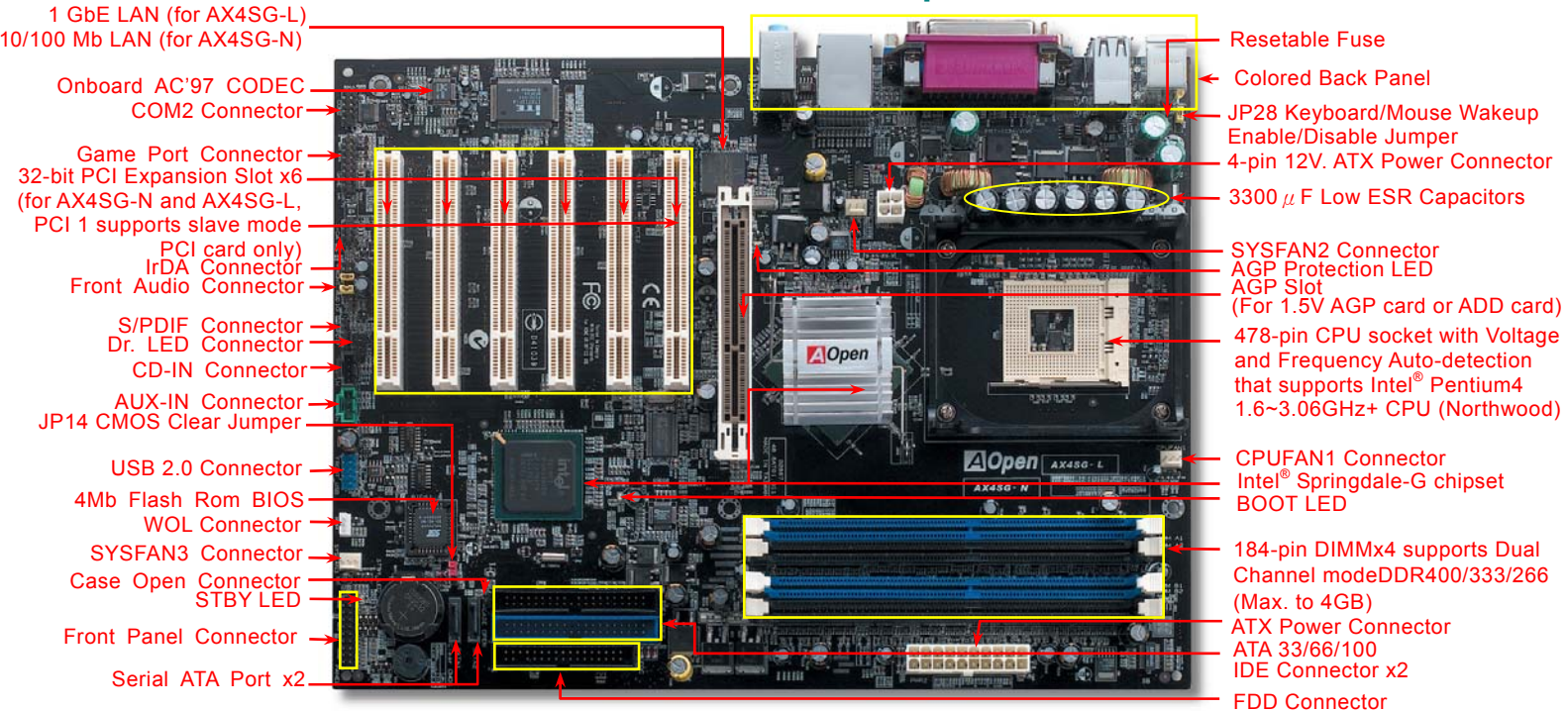

## Block Diagram

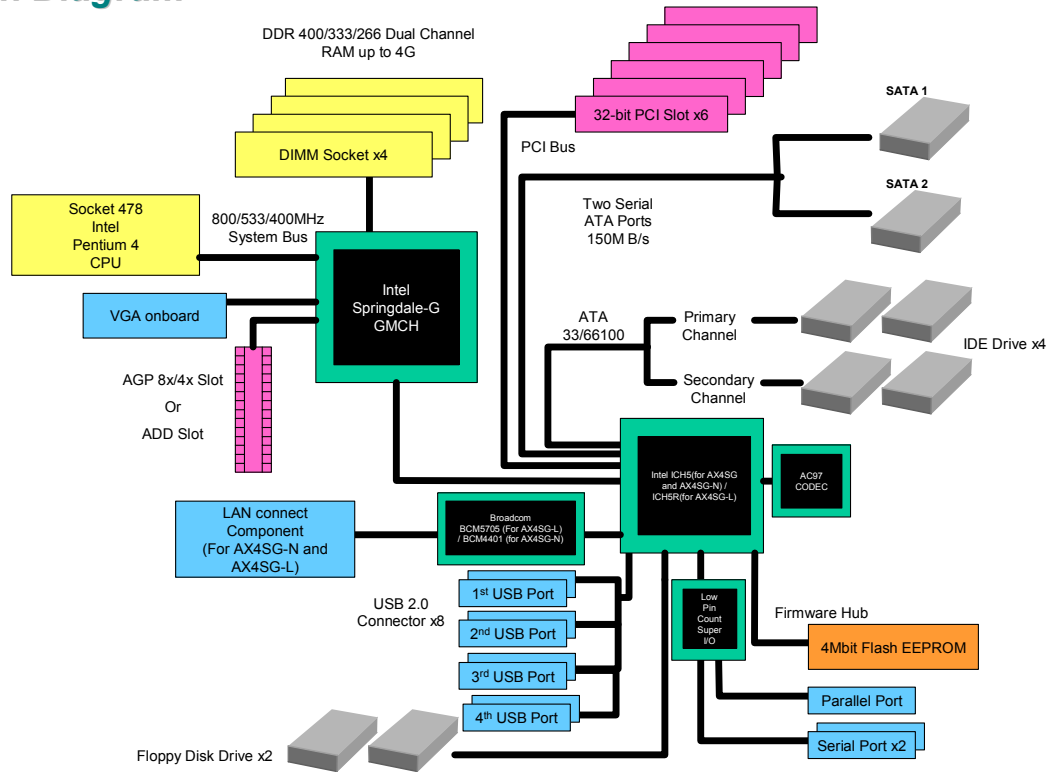

# Hardware Installation

This chapter describes jumpers, connectors and hardware devices of this motherboard.



**Note:** Electrostatic discharge (ESD) can damage your processor, disk drives, expansion boards, and other components. Always observe the following precautions before you install a system component.

1. Do not remove a component from its protective packaging until you are ready to install it.
2. Wear a wrist ground strap and attach it to a metal part of the system unit before handling a component. If a wrist strap is not available, maintain contact with the system unit throughout any procedure requiring ESD protection.

## About “Manufacturer Upgrade Optional” and “User Upgrade Optional”...

When you read this online manual and start to assemble your computer system, you may find some of functions are called “Manufacturer Upgrade Optional”, and some are called “User Upgrade Optional”. Though all AOpen motherboards include many amazing and powerful features, in some situations, these powerful features are not used to every user. Hence, we changed some key features as “Manufacturer Upgrade Optional” for you to choose. Some optional functions that can be upgraded by users, we call them “User Upgrade Optional”. As for those optional functions that can't be upgraded by ourselves, we call them “Manufacturer Upgrade Optional”. If needed, you can contact our local distributors or resellers for purchasing “User Upgrade Optional” components, and again you can visit AOpen official web site: <http://english.aopen.com.tw/> for more detail information.



## JP14 Clear CMOS Data

You can clear CMOS to restore system default setting. To clear the CMOS, follow the procedure below.

1. Turn off the system and unplug the AC power.
2. Remove ATX power cable from connector PWR2.
3. Locate JP14 and short pins 2-3 for a few seconds.
4. Return JP14 to its normal setting by shorting pins 1 & pin2.
5. Connect ATX power cable back to connector PWR2.

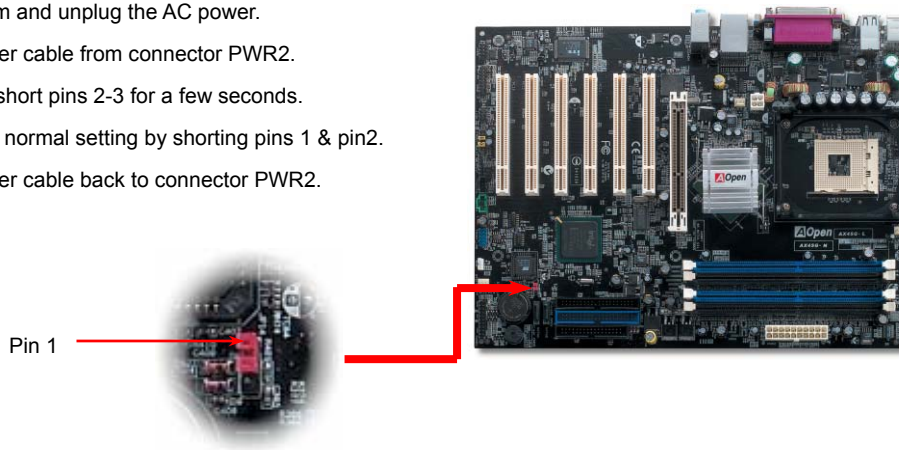

Pin 1



Normal  
(default)



Clear CMOS

**Tip:** When should I Clear CMOS?

1. Boot fails because of overlocking...
2. Forget password...
3. Troubleshooting...

## CPU Installation

This motherboard supports Intel® Pentium 4 Socket 478 series CPU. Be careful of CPU orientation when you plug it into CPU socket.

1. Pull up the CPU socket lever and up to 90-degree angle.
2. Locate Pin 1 in the socket and look for a cut edge on the CPU upper interface. Match Pin 1 and cut edge, then insert the CPU into the socket.

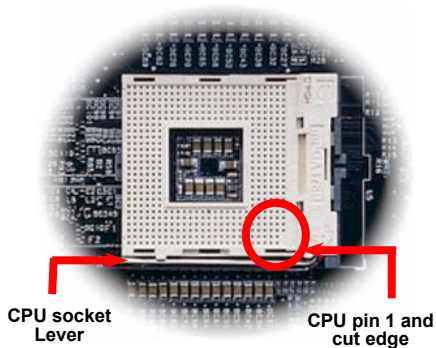
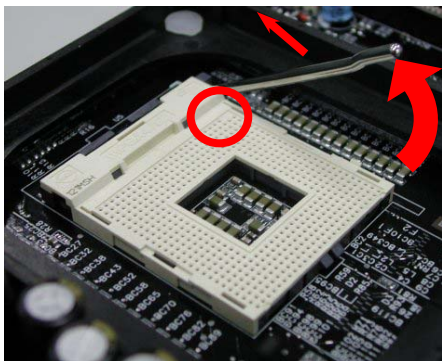

Note: These pictures are for example only, it may not exactly be the same motherboard.

3. Press down the CPU socket lever and finish CPU installation.

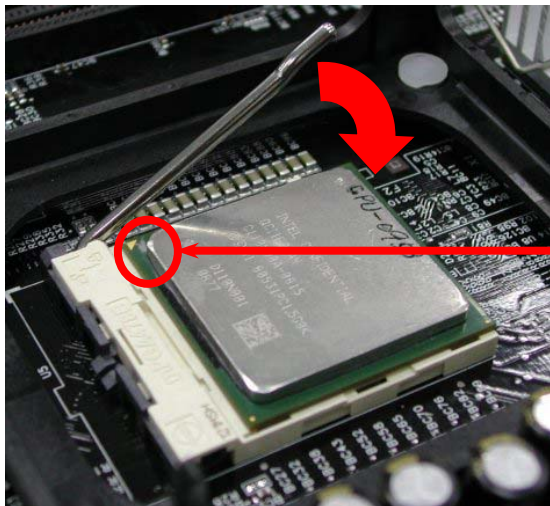

CPU cut edge

**Note:** If you do not match the CPU socket Pin 1 and CPU cut edge well, it may damage the CPU.

**Note:** This socket supports Micro-FC-PGA2 package CPU, which is the latest CPU package developed by Intel. Other forms of CPU package are impossible to be fitted in.

Note: This picture is for example only, it may not exactly be the same motherboard.

## CPU Fan Installation

This motherboard comes with a retention module attached on the CPU socket when shipped, we strongly recommend you to install AOpen special designed CPU Fan as shown below on the retention module for better heat dissipation. Please install the CPU Fan correctly as the following pictures shown.

1. Gently put the CPU Fan down on the retention module with clips aligning correctly to the four corners.

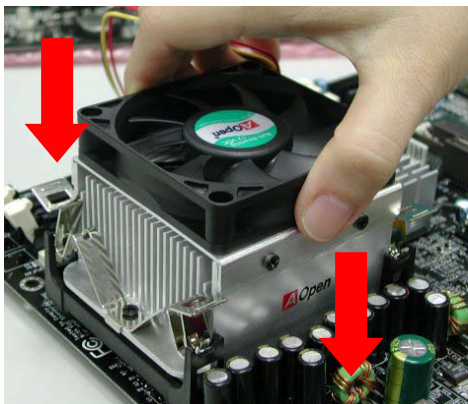

2. Pressing down the four clips with force one by one on the retention module.

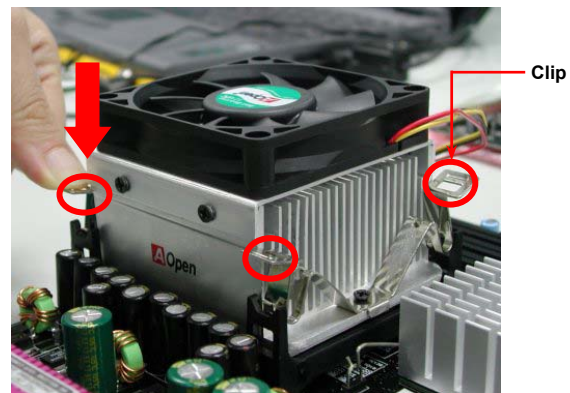



## CPU Jumper-less Design

CPU VID signal and [SMBus](#) clock generator provide CPU voltage auto-detection and allows the user to set the CPU frequency through the [BIOS setup](#), therefore no jumpers or switches are used. The disadvantages of the Pentium based jumper-less designs are eliminated. There will be no worry of wrong CPU voltage detection.

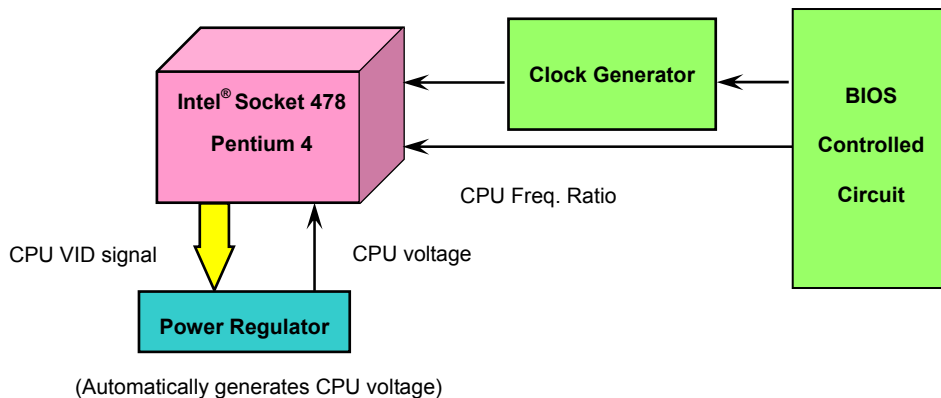

## CPU Over-current Protection

The Over Current Protection is a popular implementation on ATX 3.3V/5V/12V switching power supply. However, the new generation CPU uses different voltage with a regulator to transfer 12V to CPU voltage (for example, 2.0V), and thus makes 5V over current protection useless. This motherboard is with switching regulator onboard supporting CPU over-current protection; in conjunction with 3.3V/5V/12V power supply provide the full line over-current protection.

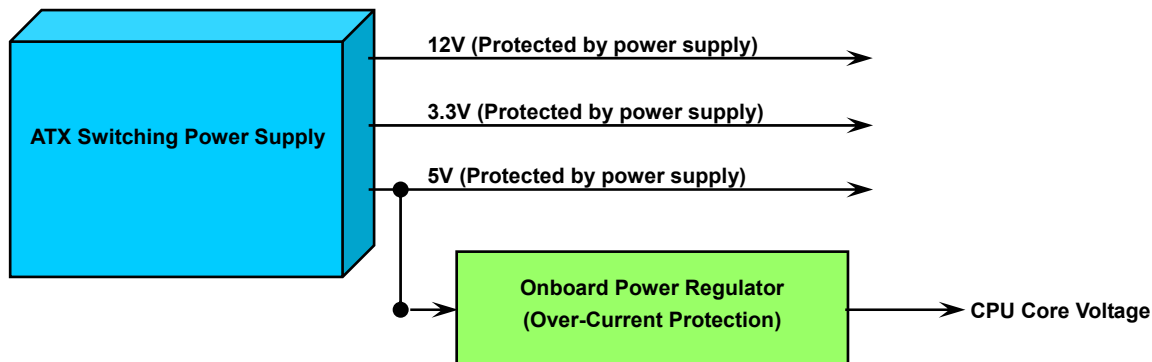

**Note:** Although we have implemented protection circuit try to prevent any human operating mistake, there is still certain risk that CPU, memory, HDD, add-on cards installed on this motherboard may be damaged because of component failure, human operating error or unknown nature reason. **AOpen cannot guaranty the protection circuit will always work perfectly.**

## Battery-less and Long Life Design

This Motherboard implements a [Flash ROM](#) and a special circuit that provide you no batter power consumption of current CPU and CMOS Setup configurations. The RTC (real time clock) can also keep running as long as the power cord is plugged. If you lose your CMOS data by accident, you can just reload the CMOS configurations from Flash ROM and the system will recover as usual.

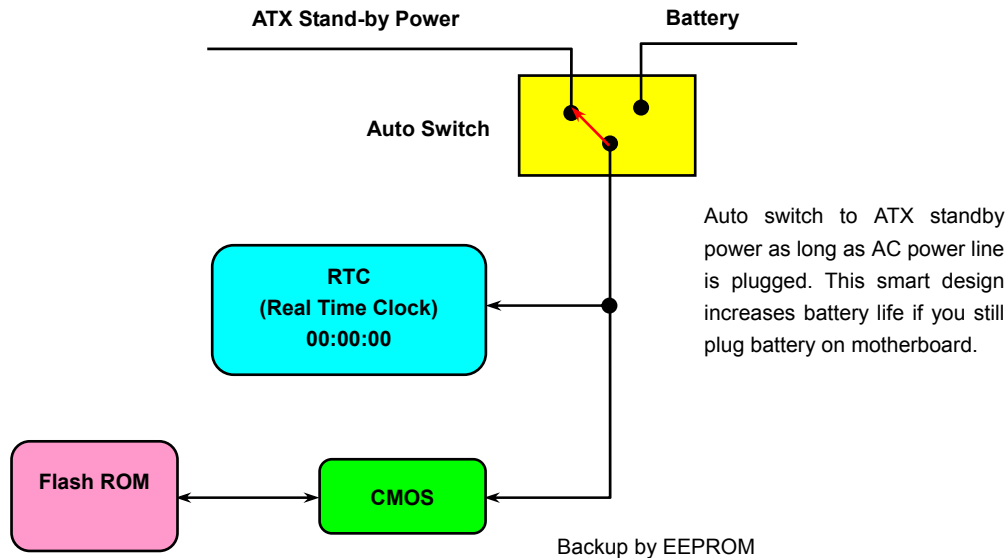

## AOpen “Watch Dog ABS”



AOpen provides a special and useful feature on this motherboard for overclockers. When you power-on the system, the BIOS will check last system [POST](#) status. If it succeeded, the BIOS will enable “Watch Dog ABS” function immediately, and set the CPU [FSB](#) frequency according to user’s settings stored in the BIOS. If system failed in BIOS POST, the “Watch Dog Timer” will reset the system to reboot in five seconds. Then, BIOS will detect the CPU’s default frequency and POST again. With this special feature, you can easily overclock your system to get a higher system performance without removing the system housing and save the hassle from setting the jumper to clear CMOS data when system hangs.

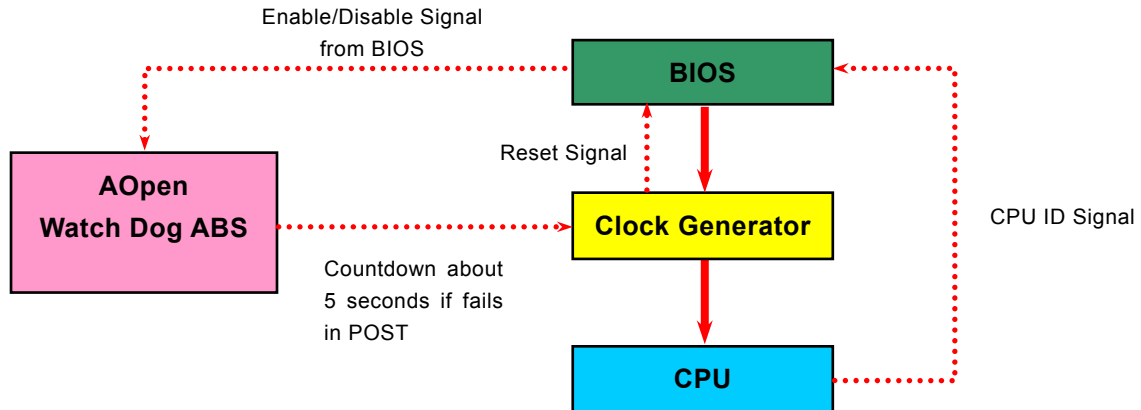

## CPU Core Voltage Auto Detectable

This motherboard supports CPU VID function. The CPU core voltage will be automatically detected and the range is from 1.1V ~ 2.025V. It is not necessary to set CPU Core Voltage.

## Setting CPU Frequency

### BIOS Setup > Frequency/Voltage Control > CPU Bus Frequency

This motherboard is CPU jumper-less design, you can set CPU frequency through the BIOS setup, and no jumpers or switches are needed.

CPU Ratio	8x, 9x, 10x,...22x, 23x, 24x
CPU FSB	100MHz~400MHz



**Tip:** If your system hangs or fails to boot because of overclocking, simply use <Home> key to restore the default setting or you can wait the AOpen "Watch Dog Timer" reset the system after five seconds and system will auto-detect hardware again.

Core Frequency = CPU **FSB** Clock \* CPU Ratio

PCI Clock = CPU FSB Clock / Clock Ratio

**AGP** Clock = PCI Clock x 2

Northwood CPU	CPU Core Frequency	FSB Clock	System Bus	Ratio
Pentium 4 1.6G	1600MHz	100MHz	400MHz	16x
Pentium 4 1.6G	1600MHz	133MHz	533MHz	12x
Pentium 4 1.7G	1700MHz	133MHz	533MHz	13x
Pentium 4 1.8G	1800MHz	100MHz	400MHz	18x
Pentium 4 2.0G	2000MHz	100MHz	400MHz	20x
Pentium 4 2.2G	2200MHz	100MHz	400MHz	22x
Pentium 4 2.26G	2260MHz	133MHz	533MHz	17x
Pentium 4 2.4G	2400MHz	100MHz	400MHz	24x
Pentium 4 2.4G	2400MHz	133MHz	533MHz	18x
Pentium 4 2.53G	2530MHz	133MHz	533MHz	19x
Pentium 4 2.6G	2600MHz	200MHz	800MHz	13X
Pentium 4 2.66G	2660MHz	133MHz	533MHz	20x
Pentium 4 2.80G	2800MHz	133MHz	533MHz	21x
Pentium 4 2.80G	2800MHz	200MHz	800MHz	14x
Pentium 4 3.0G	3000MHz	200MHz	800MHz	15x
Pentium 4 3.06G	3060MHz	133MHz	533MHz	23x

**Note:** Intel Springdale-G chipset only support Northwood processors, and don't support Willamette or Celeron processors. Northwood processor would detect the clock ratio automatically, you may not be able to adjust the clock ratio in BIOS manually.

**Warning:** Intel® Spingdale-G chipset supports maximum 400/533/800 MHz (100/133/200MHz\*4) system bus and 66MHz AGP clock; higher clock setting may cause serious system damage.



## CPU and System Fan Connector (with H/W Monitoring)

Plug in the CPU fan cable to the 3-pin **CPUFAN1** connector. If you have chassis fan, you can also plug it on **SYSFAN2** or **SYSFAN3** connector.

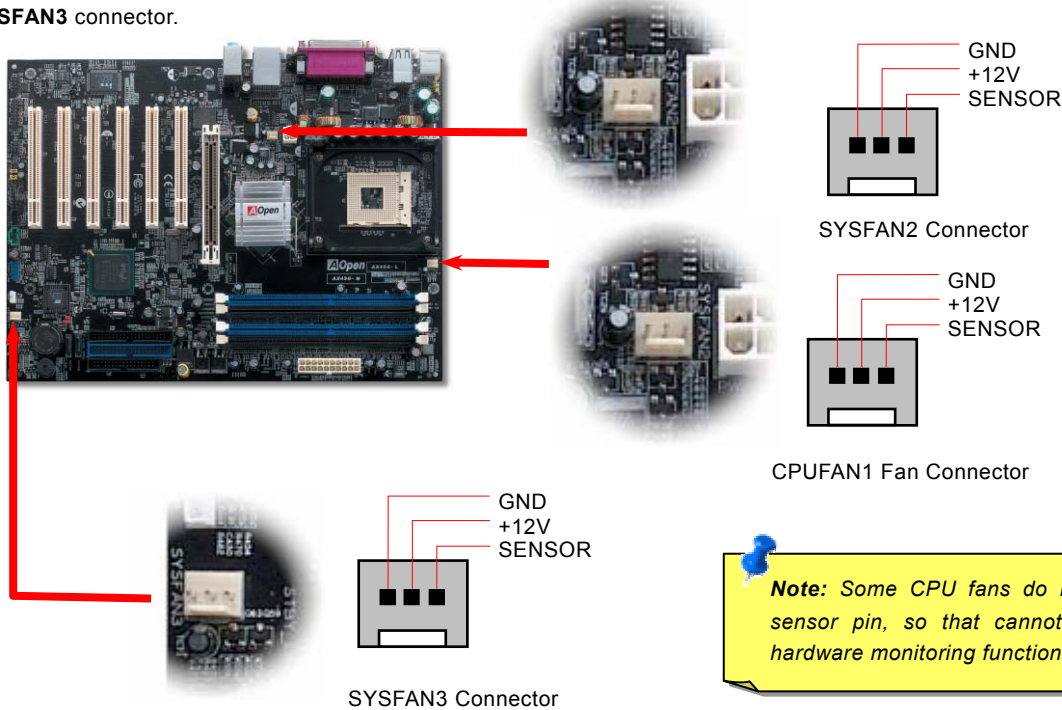

**Note:** Some CPU fans do not have sensor pin, so that cannot support hardware monitoring function.



## JP28 Keyboard/Mouse Wake-up Enable/Disable Jumper

This motherboard provides keyboard / mouse wake-up function. You can use JP28 to enable or disable this function, which could resume your system from suspend mode with keyboard or mouse installed. The factory default setting is set to "Disable" (1-2), and you may enable this function by setting the jumper to 2-3.

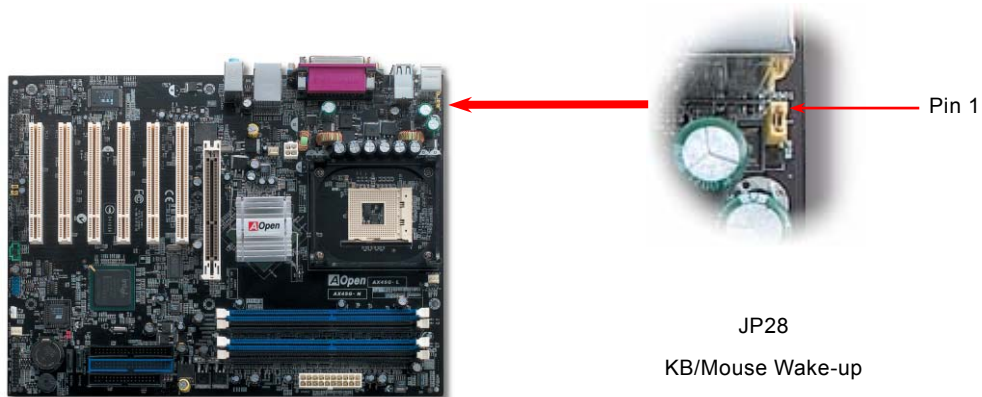

JP28  
KB/Mouse Wake-up

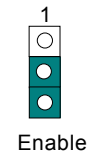
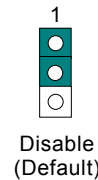



## DIMM Sockets

This motherboard has four 184-pin DDR DIMM sockets that allow you to install 128-bit dual channel [DDR400](#), [DDR333](#) or [DDR266](#) memory up to 4GB. Only non-ECC DDR RAM is supported. Please install suitable modules; otherwise serious damage may occur on memory sockets or your RAM modules. Please note that when you install DDR333 memory module and have your CPU FSB set at 800MHz, the memory can run with the speed of DDR320. For other limitation of CPU types, please see the table below.

Item	DDR266	DDR333	DDR400
CPU FSB 400MHz	V	X	X
CPU FSB 533MHz	V	V	X
CPU FSB 800MHz	V	⊖	V

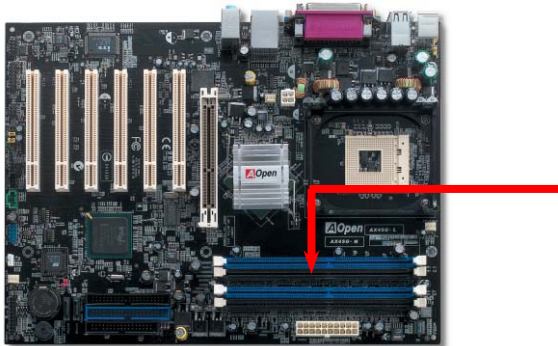

DIMMA1  
DIMMA2  
DIMMB1  
DIMMB2

**Warning:** This motherboard supports DDR RAM. Please do not install the SDRAM on the DDR RAM sockets; otherwise it will cause serious damage on memory sockets or SDRAM module.

*Note: To run dual channel speed, you have to use the same type memory modules installed on two DIMM. If you install two different sized modules, the system can only run single channel mode and with the speed of that lower memory module.*

## How to Install Memory Modules

Please follow the procedure as shown below to finish memory installation.

1. Make sure the DIMM module's pin face down and match the socket's size as depicted below.

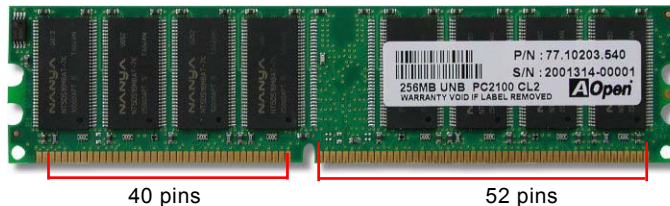

**Note:** Please pay attention to the blue slots. To run dual channel speed, you should insert the RAM in the slot of DIMM A1 and DIMM B1 or DIMM A2 and DIMM B2. Please don't use the different frequency DIMM on dual channel.

2. Insert the module straight down to the DIMM slot with both hands and press down firmly until the DIMM module is securely in place.

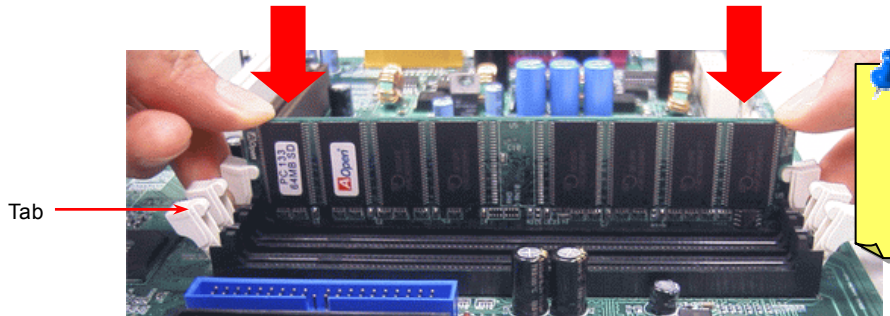

**Note:** The tabs of the DIMM slot will close-up to hold the DIMM in place when the DIMM touches the slot's bottom.

3. Repeat step 2 to finish additional DIMM modules installation.

## Front Panel Connector

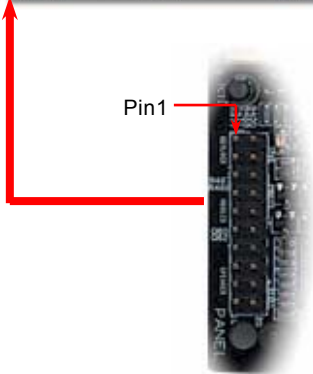
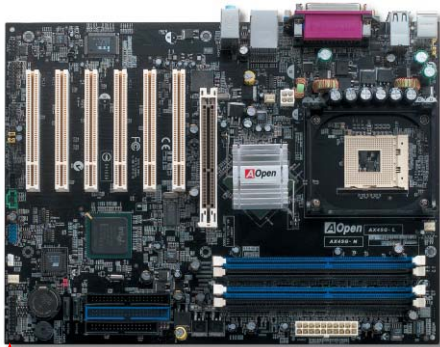

Attach the power LED, speaker, power and reset switch connectors to the corresponding pins. If you enable "Suspend Mode" item in BIOS Setup, the ACPI & Power LED will keep flashing while the system is in suspend mode.

Locate the power switch cable from your ATX housing. It is 2-pin female connector from the housing front panel. Plug this connector to the soft-power switch connector marked **SPWR**.

Suspend Type	ACPI LED
Power on Suspend (S1) or Suspend to RAM (S3)	Blinking between green and red.
Suspend to Disk (S4)	The LED will be turned off

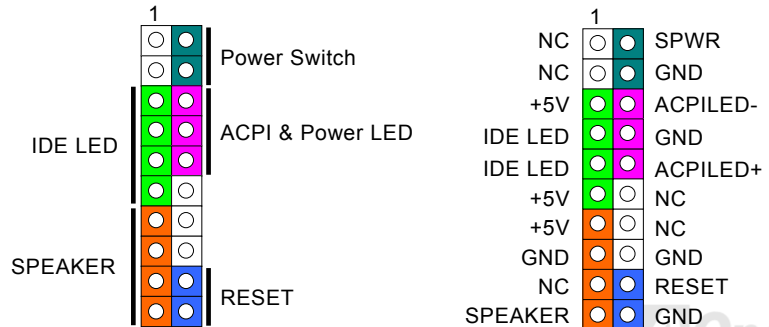

## ATX Power Connector

This motherboard comes with a 20-pin and 4-pin ATX power connector. Make sure you plug in the right direction. We strongly recommend you to connect the 4-pin 12V ATX connector before connecting the 20-pin ATX power connector and use standard power supply specially designed for Pentium 4 system.

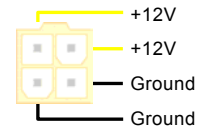
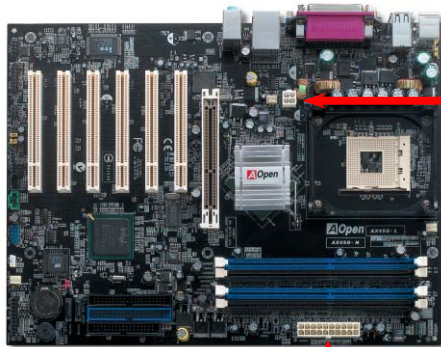

4-Pin 12V ATX Power Connector



20-Pin Power Connector

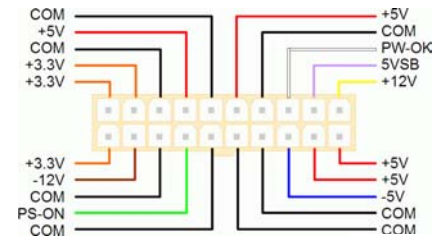

## **AC Power Auto Recovery**

A traditional ATX system should remain at power off stage when AC power resumes from power failure. This design is inconvenient for a network server or workstation, without an UPS, that needs to keep power-on. This motherboard implements an AC Power Auto Recovery function to solve this problem.



## STBY LED and BOOT LED

Both STBY LED and BOOT LED are AOpen's considerate designs that aim at providing you friendly system information. The STBY LED will light up when power is provided to the motherboard. This is a convenient indication for you to check the system power status in many circumstances such as power on/off, stand-by mode and RAM power status during Suspend to RAM mode.

BOOT LED will keep blinking when you power the system on and when your system is under [POST \(Power-On Self Test\)](#). After POST diagnoses everything alright and finishes the booting, the LED will stay on otherwise it will remain flashing to warn you that mistakes have occurred during POST.

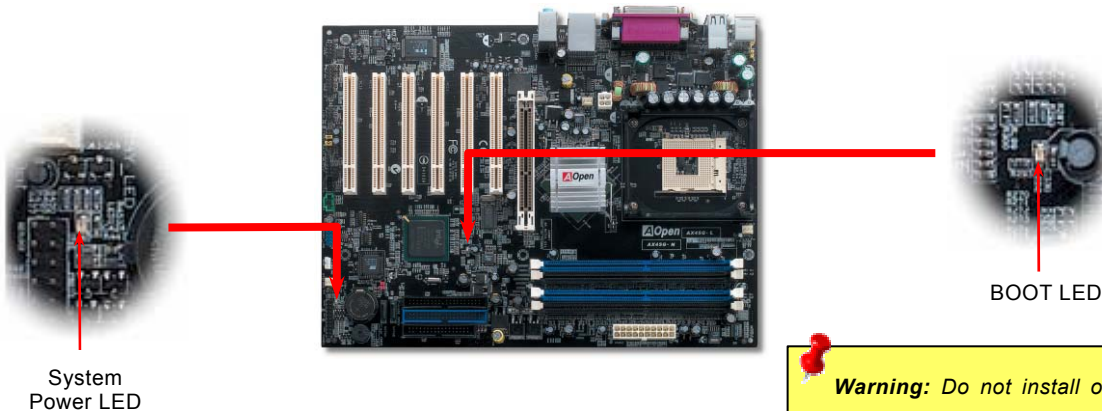

**Warning:** Do not install or remove the DIMM module or others devices when the STBY LED lights on.

## IDE and Floppy Connector

Connect 34-pin floppy cable and 40-pin IDE cable to floppy connector FDD and IDE connector. Be careful of the pin1 orientation. Wrong orientation may cause system damage.

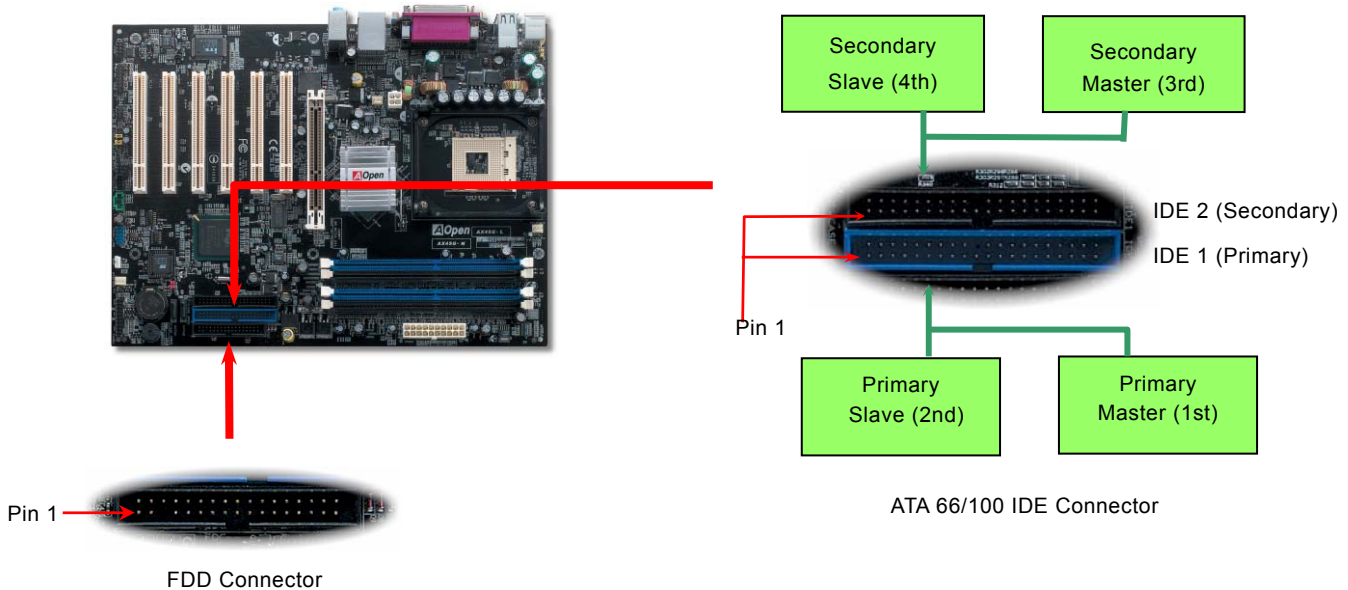

IDE1 is also known as the primary channel, IDE2 is known as the secondary channel. Each channel supports two IDE devices that make a total of four devices. In order to work together, the two devices on each channel must be set differently to **Master** and **Slave** mode. Either one can be the hard disk or the CDROM. The setting as master or slave mode depends on the jumper on your IDE device, so please refer to your hard disk and CDROM manual accordingly.



**Warning:** *The specification of the IDE cable is a maximum of 46cm (18 inches); make sure your cable does not exceed this length.*



**Tip:**

1. *For better signal quality, it is recommended to set the far end side device to master mode and follow the suggested sequence to install your new device. Please refer to above diagram*
2. *To achieve the best performance of Ultra DMA 66/100 hard disks, a special 80-wires IDE cable for Ultra DMA 66/100 is required.*





## Serial ATA Supported (with RAID function, RAID for AX4SG-L only)

The traditional parallel ATA specification has defined the standard storage interface for PCs with its original speed of just 3 Mbytes/second since the protocol was introduced in the 1980s. And the latest generation of the interface, Ultra ATA-133, has been developed further with a burst data transfer rate of 133 Mbytes/second. However, while ATA has enjoyed an illustrious track record, the specification is now showing its age and imposes some serious design issues on today's developers, including a 5-volt signaling requirement, high pin count, and serious cabling headaches.

The Serial ATA specification is designed to overcome these design limitations while enabling the storage interface to scale with the growing media rate demands of PC platforms. Serial ATA is to replace parallel ATA with the compatibility with existing operating systems and drivers, adding performance headroom for years to come. It reduces voltage and pins count requirements and can be implemented with thin and easy to route cables.

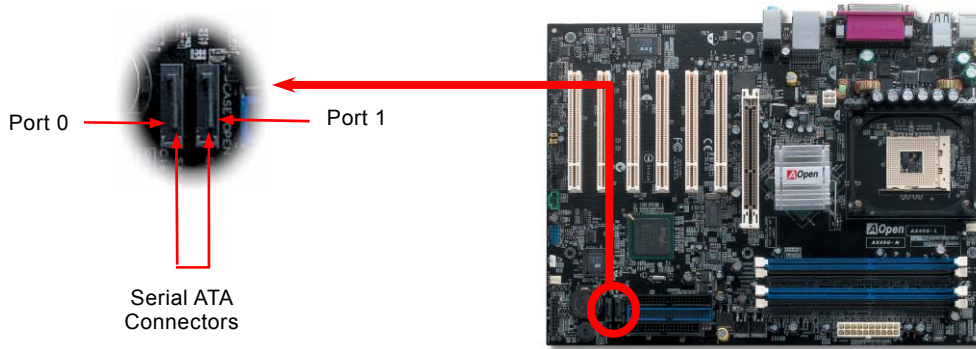

## Connecting Serial ATA Disk

To connect a Serial ATA disk, you have to have a 7-pin serial ATA cable. Connect two ends of the serial ATA cable to the serial ATA header on the motherboard and the disk. Like every other traditional disk, you also have to connect a power cable. Please be noted that it is a jumper free implement; you don't need to set jumpers to define a master or slave disk. When serial ATA hard disks are installed on serial ATA ports, the one connected on Port 0(SATA 1) will be set as the first boot device automatically. Please be noted that it doesn't support Hot-Plug in function.



Item	Parallel ATA	Serial ATA
Bandwidth	100/133 MB/Sec	150/300/600 MB/Sec
Volts	5V	250mV
Pins	40	7
Length Limitation	18 inch (45.72cm)	1 meter (100cm)
Cable	Wide	Thin
Ventilation	Bad	Good
Peer-to-Peer	No	Yes

**Comparison between Parallel ATA and Serial ATA**

## Adjusting Your Hard Disk

Except its original 2 sets of parallel IDE, this motherboard does come with the support for the latest Serial ATA hard disk. If you are unable to find your newly installed Serial ATA hard disks on your operating system after you have had installed them on, the problem mainly lies in the BIOS setting. You may simply adjust BIOS settings to have them work properly.

After having properly installed your hard disks, you may directly get into the BIOS setting screen for adjustment. You may simply press “Integrated Peripherals → On-Chip IDE Device → On-Chip Serial ATA” to choose your preferable mode. If you have no intention of changing its setting, the default would be Auto.

The screenshots show the following navigation steps:

- Phoenix - AwardBIOS CMOS Setup Utility**: Main menu with options like Standard CMOS Features, Advanced BIOS Features, and Integrated Peripherals.
- Phoenix - AwardBIOS CMOS Setup Utility Integrated Peripherals**: Sub-menu where OnChip IDE Device is selected.
- Phoenix - AwardBIOS CMOS Setup Utility OnChip IDE Device**: Screen showing IDE settings for Primary and Secondary PCI IDE, PIO, and UDMA. The On-Chip Serial ATA Setting is highlighted with 'Auto'.
- Item Help**: A help window for the On-Chip Serial ATA setting, explaining modes like SATA, SATA0, and SATA1, and their compatibility with SATA and PATA drives.

Key settings visible in the OnChip IDE Device screen:

- IDE HDD Block Mode: Enabled
- On-Chip Primary PCI IDE: Enabled
- IDE Primary Master PIO: Auto
- IDE Primary Slave PIO: Auto
- IDE Primary Master UDMA: Auto
- IDE Primary Slave UDMA: Auto
- On-Chip Secondary PCI IDE: Enabled
- IDE Secondary Master PIO: Auto
- IDE Secondary Slave PIO: Auto
- IDE Secondary Master UDMA: Auto
- IDE Secondary Slave UDMA: Auto

On-Chip Serial ATA Setting \*\*\*

- x SATA Mode: IDE
- On-Chip Serial ATA: **Auto**
- x Serial ATA Port0 Mode: SATA0 master
- Serial ATA Port1 Mode: SATA1 master

Item Help text:

[Disabled]: Disabled SATA Controller.  
 [Auto]: Auto arrange by BIOS.  
 [Combined Mode]: PATA and SATA are combined. Max. of 2 IDE drives in each channel.  
 [Enhanced Mode]: Enable both SATA and PATA. Max. of 6 IDE drives are supported.  
 [SATA only]: SATA is operating in legacy mode.

If you intend to change the default setting, simply press **Enter** for a list of selection:

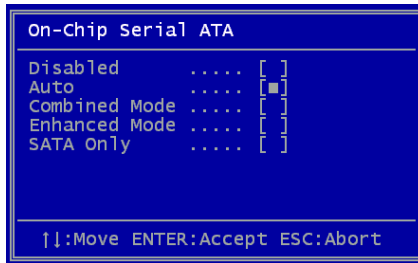

1. **Disabled:** You may choose this item if you're sure that only traditional IDE hard disks had been installed on your system. Disabling this item may also cancel the detection to Serial ATA hard disk during POST, which theoretically, could speed up your boot-up timing for a little bit; however, please remember to re-adjust the settings here if you intend to use Serial ATA hard disk later.
2. **Auto:** This is the default setting upon receipt of the motherboard. Basically, if your system functions properly, it's not necessary to change it. The system will automatically recognize the first hard disk on IDE1 as the first boot device.

*Note:* Please be informed that when you are using Windows98/ME with six hard disks fully installed, Auto mode is not able to function properly, it's just because Windows98/Me is not able to energize Enhanced Mode to detect all hard disks.

3. **Combined Mode:** If you have had installed traditional IDE hard disks and Serial ATA hard disks at the same time, then you may choose this Combined Mode. Under this mode, you may randomly choose either IDE hard disks or Serial ATA hard disk as your first boot device. But please be aware that Serial ATA will exist with IDE in a mapping way, which also means it will occupy one of the IDE Channel and left you with one IDE Channel only.
4. **Enhanced Mode:** If you are using the latest operating system (say, Windows XP, Windows.NET Server), it is highly recommended to select Enhanced Mode. The system would be able to detect all six devices (traditional IDE x4, Serial ATA x 2) completely and functions perfectly under this mode. But please be noted that it is defaulted with using traditional IDE as the first boot device.

*Note:* From our practical lab tests, we found no obvious problem or mistakes happened under Windows2000 operating system, but, however, it is not within the regulation recommended by Intel.

5. **SATA Only:** You may select this SATA only mode if you have had installed Serial ATA hard disks only. It also allows you to select booting sequence from Port0 (SerialATA1) or Port1 (SerialATA2).

## What's RAID 0 (Striping / Span)?

RAID level 0, which is the fastest drive array you can have, is a performance-oriented disk mapping method. The data in this array gets written across a stripe or different disks for a faster transfer. This technique has striping but no redundancy of data. It offers the best performance but no fault-tolerance. Reads and writes sector of data interleaved between multiple drives. When any disk member fails, it affects the entire array. Performance is better than a single drive since the workload is balanced between the array members. This array type is for high performance systems. Identical drives are recommended for performance as well as data storage efficiency. The disk array data capacity is equal to the number of members times the smallest member capacity. For example, one 40GB and one 60GB drives will form an 80GB (40GBx2) disk array.

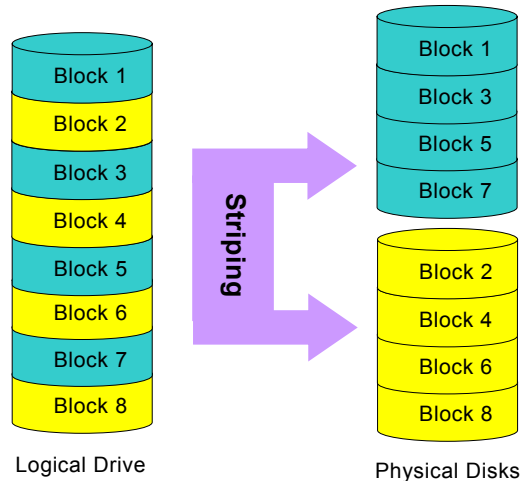

## Arouse RAID function in BIOS

After having properly installed your Serial ATA hard disks, you may directly get into the BIOS setting screen for adjustment. You may simply press “Integrated Peripherals → OnChip IDE Device → On-Chip Serial ATA” to choose Enhanced mode. In order to utilize Serial ATA function, please select RAID in SATA Mode. Finally, do save the changes and exit BIOS setup screen.

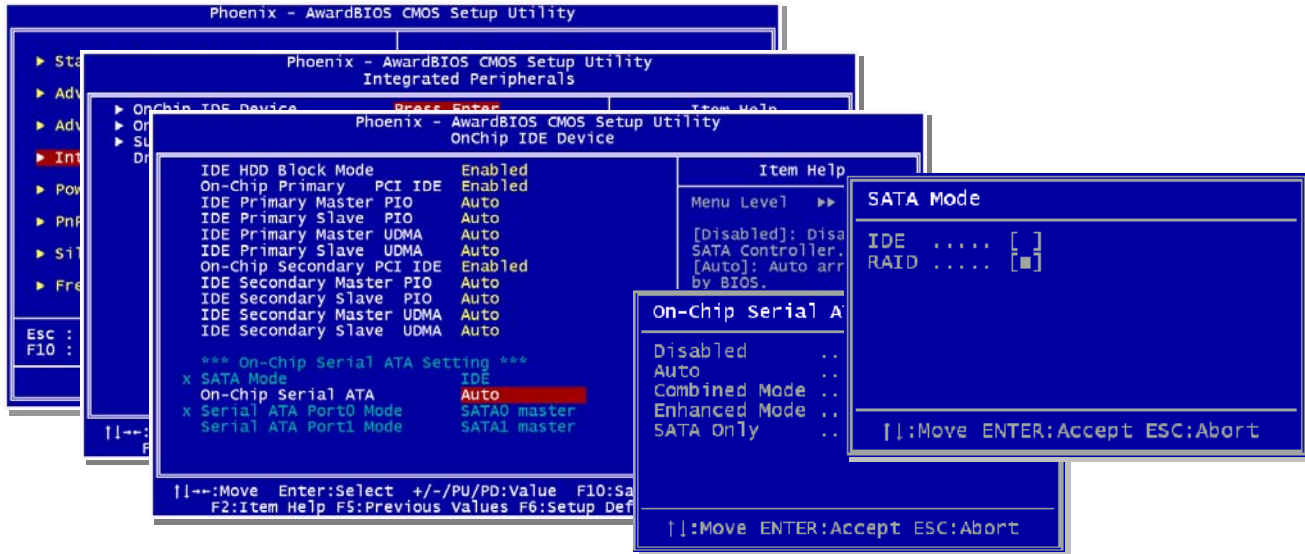

## RAID Configuration Utility

In order to make sure your system can recognize and operate Serial ATA RAID device smoothly, we have to enter RAID Configuration Utility to do some configuration. After finishing the BIOS setup and reboot, you will see [Press CTRL + I to enter configuration Utility] about half way through the boot up. Please press these two buttons simultaneously. When you enter you will be presented with a screen as shown below:

```
Intel(R) RAID for Serial ATA - RAID BIOS v3.0.0.2344
Copyright(C) 2003 Intel Corporation. All Rights Reserved.

RAID Volumes:
None defined.

Non-RAID Disks:
Port Drive Model      Serial #      Size  Status  Bootable
0 SAMSUNG SP8004H     047511FT602315  74.5GB Normal  Yes
1 Maxtor 6Y060M0     Y2002KGF      57.2GB Normal  Yes

Press <CTRL-I> to enter configuration utility..
```

```
Intel(R) RAID for Serial ATA - RAID Configuration Utility
Copyright(C) 2003 Intel Corporation. All Rights Reserved. v3.0.0.2344
[ MAIN MENU ]
1. Create RAID Volume
2. Delete RAID Volume
3. Reset Disks to Non-RAID
4. Exit
```

```
[ DISK/VOLUME INFORMATION ]

RAID Volumes:
None defined.

Non-RAID Disks:
Port Drive Model      Serial #      Size  Status  Bootable
0 SAMSUNG SP8004H     047511FT602315  74.5GB Normal  Yes
1 Maxtor 6Y060M0     Y2002KGF      57.2GB Normal  Yes

[ F1 ]-select  [ Esc ]-Exit  [ ENTER ]-select Menu
```

### 1. Create RAID Volume:

This section allows users to choose the strip size and disk volume of RAID.

### 2. Delete RAID Volume:

This section allows users to delete the volume of RAID. Please be noted that deleting a volume will destroy volume data and cause any member disks to become available as non-RAID disks.

### 3. Reset Disks to Non-RAID:

Users can remove any internal RAID structures from all RAID disks, including disks with working volume. Select "Yes" will cause all data on any disk to be lost.

## Installing IAA Driver (Intel Application Accelerator RAID Edition)

You can install Intel IAA RAID Edition Driver to increase the performance of software applications and reduce PC boot times. The IAA RAID Edition is designed to provide functionality for the Intel (R) ICH5R SATA RAID Controller. This product is available for use on Pentium (R) 4 processor-based systems with an ICH5R I/O Controller Hub and running Microsoft Windows XP. Software installation is flexible and fully automated for Windows XP. You can find it in the AOpen Bonus Pack.

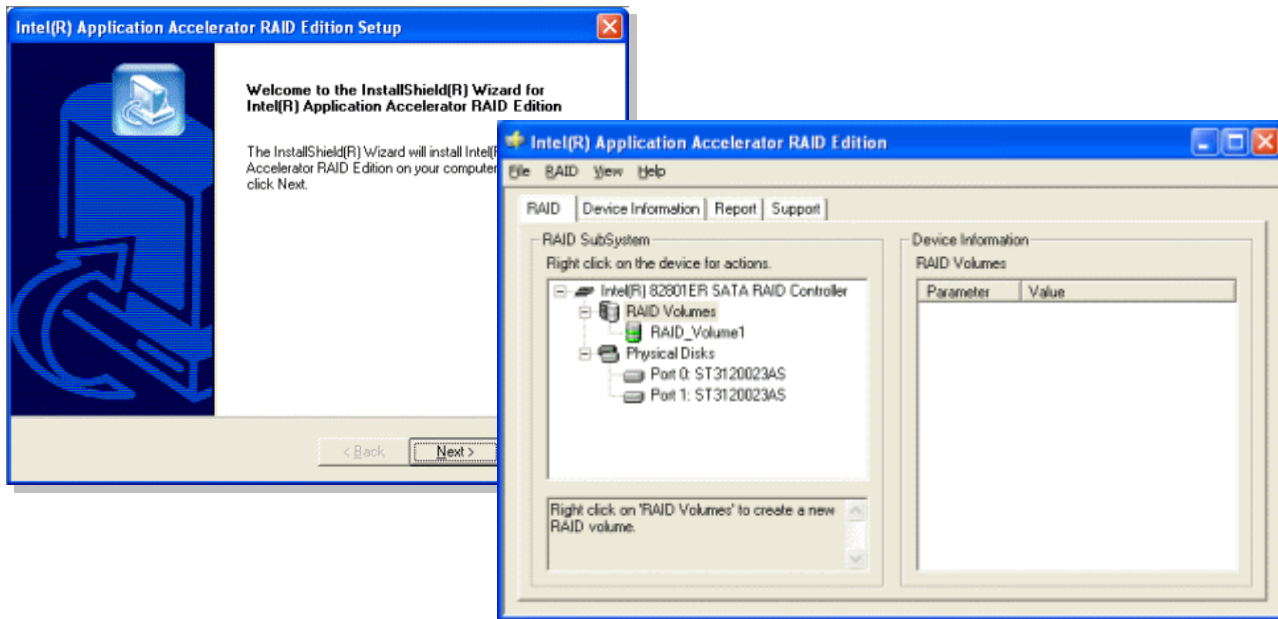



## IrDA Connector

The IrDA connector can be configured to support wireless infrared module, with this module and application software such as Laplink or Windows 98 Direct Cable Connection, the user can transfer files to or from laptops, notebooks, PDA devices and printers. This connector supports HPSIR (115.2Kbps, 2 meters) and ASK-IR (56Kbps).

Install the infrared module onto the IrDA connector and enable the infrared function from BIOS Setup, UART Mode, make sure to have the correct orientation when you plug in the IrDA connector.

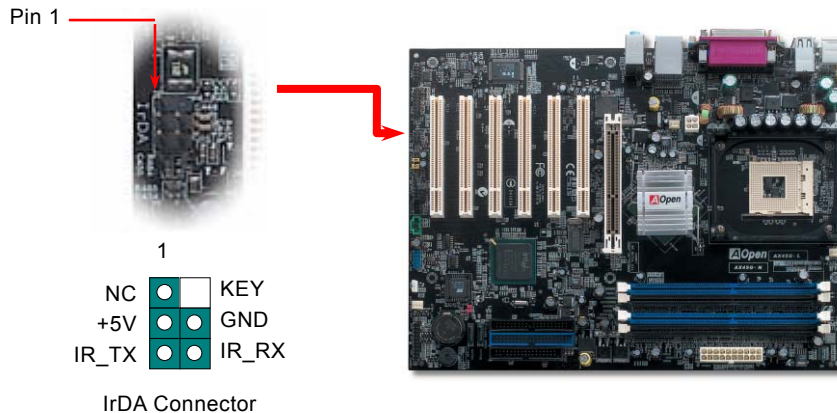



## S/PDIF (Sony/Philips Digital Interface) Connector

S/PDIF (Sony/Philips Digital Interface) is a newest audio transfer file format, which provides impressive audio quality through optical fiber and allows you to enjoy digital audio instead of analog audio. Normally there are two S/PDIF outputs as shown, one for RCA connector, the most common one used for consumer audio products, and the other for optical connector with better audio quality. Through a specific audio cable, you can connect the S/PDIF connector to other end of the S/PDIF audio module, which bears S/PDIF digital output. However, you must have a S/PDIF supported speaker/amplifier/decoder with S/PDIF digital input to connect to the S/PDIF digital output to make the most out of this function.

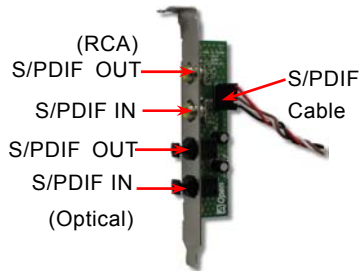





S/PDIF Module  
(User Upgrade Optional)

Pin 1



S/PDIF Connector

- 1  +5V
-  NC
- 2  SPDIFOUT
- 3  GND
- 5  SPDIFIN

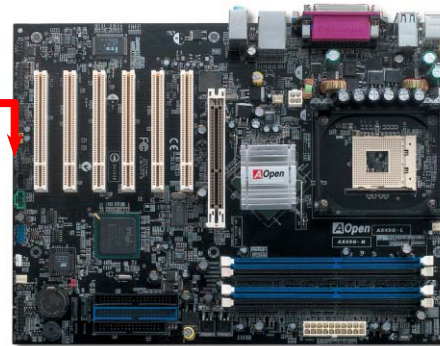

## Super 5.1 Channel Audio Effect



This motherboard comes with an ALC650 CODEC, which supports high quality of 5.1 Channel audio effects, bringing you a brand new audio experience. On the strength of the innovative design of ALC650, you're able to use standard line-jacks for surround audio output without connecting any external module. To apply this function, you have to install the audio driver in the Bonus Pack CD as well as an audio application supporting 5.1 Channel. Picture below represents the standard location of all speakers in 5.1Channel sound track. Please connect the plug of your front speakers to the green "Speaker out" port, rear speakers' plug to the blue "Line in" port and both of the center and subwoofer speakers to the red "MIC in" port.

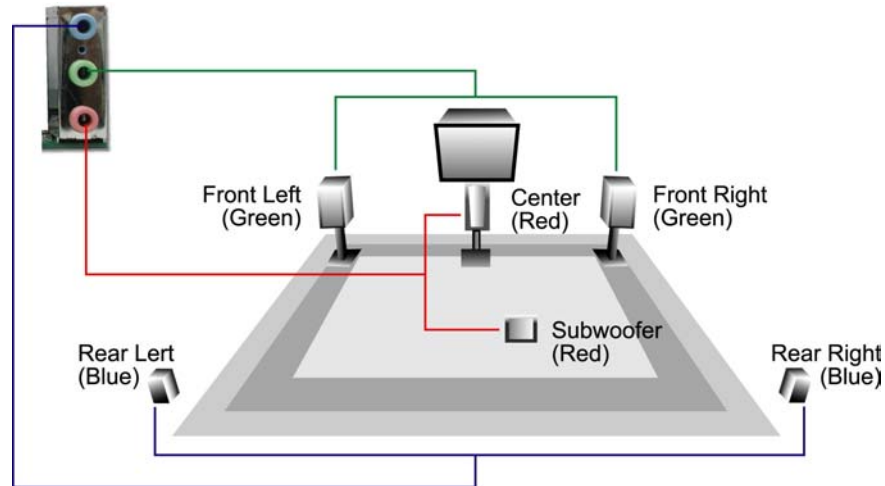

## AGP (Accelerated Graphic Port) 8X Expansion Slot



AX4SG / AX4SG-N / AX4SG-L provide an [AGP](#) 8x slot. The AGP 8X is a bus interface targeted for high-performance 3D graphic. AGP uses both rising and falling edge of the 66MHz clock, for 4X AGP, the data transfer rate is  $66\text{MHz} \times 4\text{bytes} \times 4 = 1056\text{MB/s}$ . AGP is now moving to AGP 8x mode, which is  $66\text{MHz} \times 4\text{bytes} \times 8 = 2.1\text{GB/s}$ . This AGP slot could automatically become an AGP slot or a Multiplexed Intel DVO Output depending on what kind of cards inserted, like AGP, or ADD (AGP Digital Display) cards. With ADD card cabled to this slot, Multiplexed Intel DVO output could provide high-speed digital connection for digital displays or TV-OUT functionality. You can also adjust AGP voltage in BIOS within a range from 1.5V to 1.7V.

**Warning:** It is strongly recommended not to adjust voltage/clock of AGP/PCI when connecting any SATA service. It is because when the voltage/clock for AGP/PCI is adjusted, the clock for SATA couldn't keep 100MHz, and the system will be unstable.

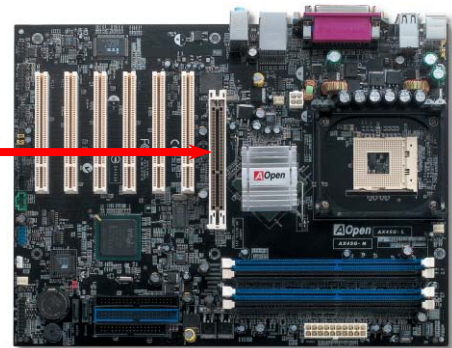
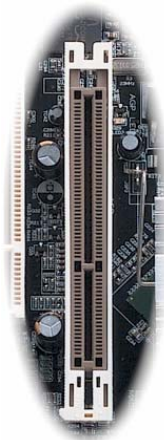

## AGP Protection Technology and AGP LED

With the outstanding R&D ability of AOpen and its specially developed circuit, this model implements a blend new technology to protect your motherboard from being damaged by over-voltaging of AGP card. When AGP Protection Technology is implemented, this motherboard will automatically detect the voltage of AGP card and prevent your chipsets from being burnt out. Please note that if you install an AGP card with 3.3V, which is not supported, the AGP LED on the motherboard will light up to warn you the possible damage of the exceeding voltage. You may contact your AGP card vendor for further support.

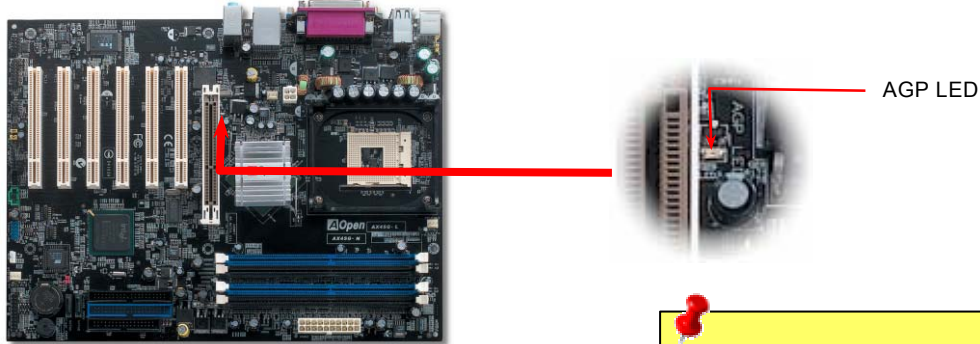

**Warning:** It is strongly recommended not to install a 3.3V AGP card, which is not supported. When you do so, the AGP LED on the motherboard will light up to warn you the possible damage.

## **WOL (Wake on LAN)**

To use Wake On LAN function, you must have a network card with chipset that supports this feature, and connect a cable from LAN card to motherboard WOL connector. The system identification information (probably IP address) is stored on network card and because there is a lot of traffic on the Ethernet, you need to install network management software, such as ADM, for the checking of how to wake up the system. Note that, at least 600mA ATX standby current is required to support the LAN card for this function.

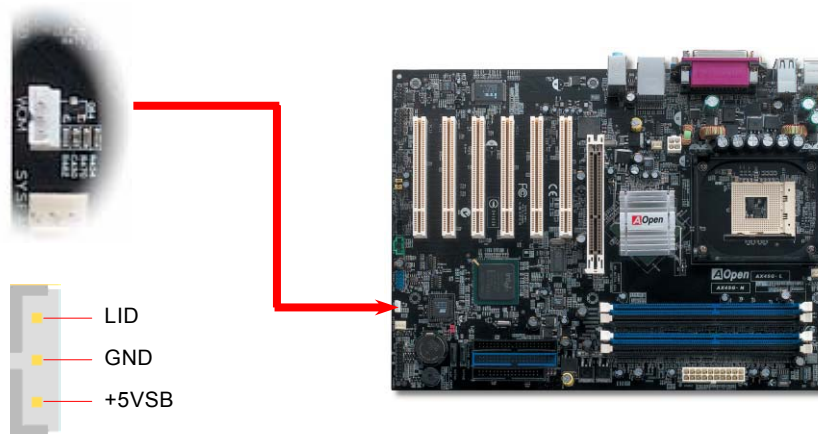

WOL Connector

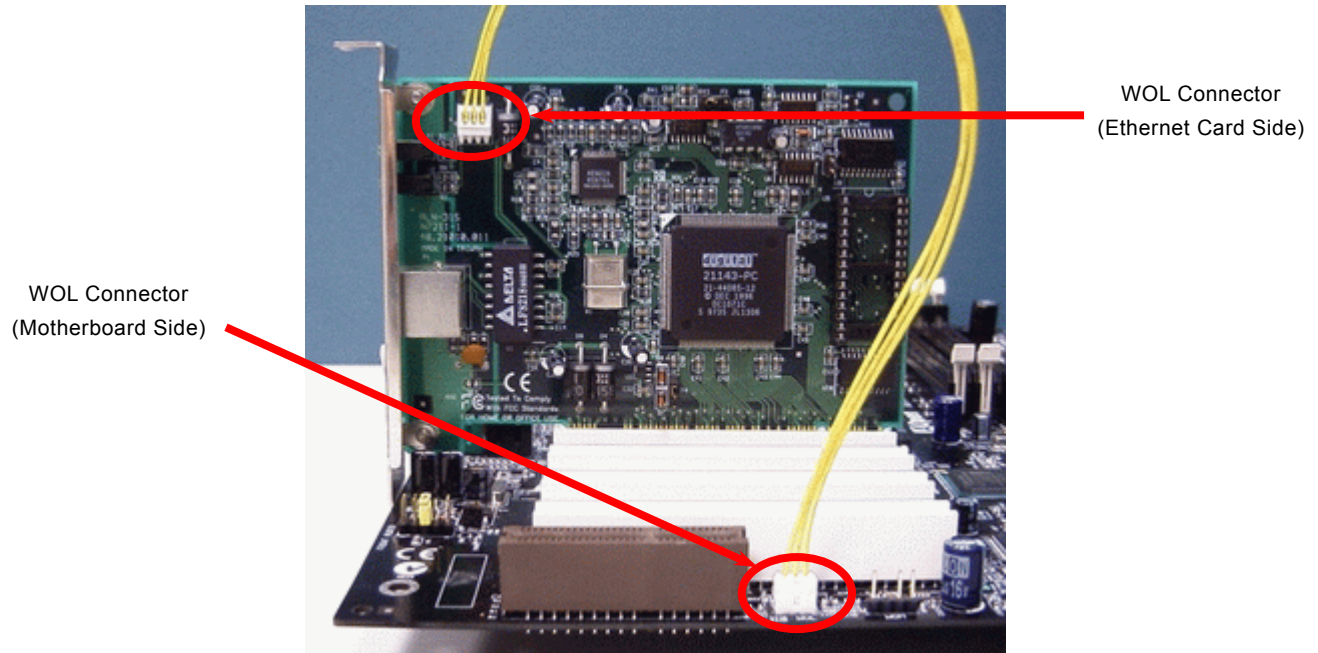

Note: This picture is for example only, it may not exactly be the same motherboard.

## Color Coded Back Panel

The onboard I/O devices are PS/2 Keyboard, PS/2 Mouse, COM1 and VGA, RJ45 LAN, Printer, [USB2.0](#), AC97 sound and game ports. The view angle of drawing shown here is from the back panel of the housing.

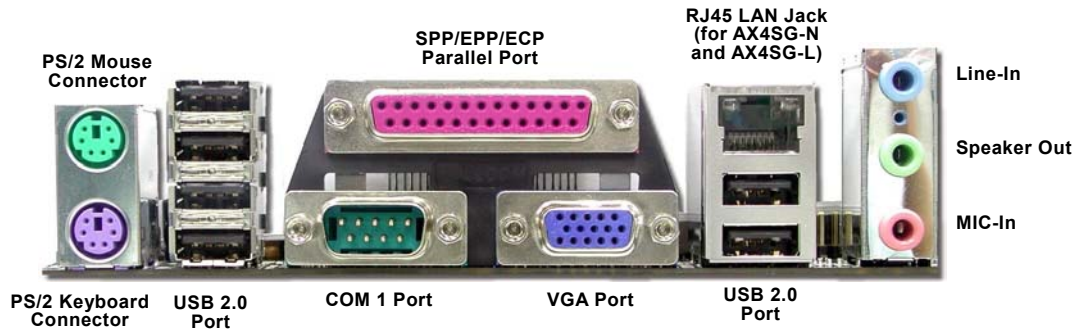

PS/2 Keyboard:	For standard keyboard, which use a PS/2 plug.
PS/2 Mouse:	For PC-Mouse, which use a PS/2 plug.
USB Port:	Available for connecting USB devices.
Parallel Port:	To connect with SPP/ECP/EPP printer.
COM1 Port:	To connect with pointing devices, modem or others serial devices.
VGA Connector:	To connect with PC monitor.
Speaker Out:	To External Speaker, Earphone or Amplifier.
Line-In:	Comes from the signal sources, such as CD/Tape player.
MIC-In:	From Microphone.





**Support 10/100/1000 Mbps LAN onboard (for AX4SG-N and AX4SG-L)**

The South Bridge ICH5(R) includes a fast Ethernet controller on chip. On the strength of Broadcom BCM5705(for AX4SG-L) or BCM4401(for AX4SG-N) LAN controller on board, which is a highly-integrated Platform LAN Connect device, AX4SG-L provides 10/100/1000M bps Ethernet for office and home use and AX4SG-N provides 10/100M bps Ethernet, the Ethernet RJ45 connector is located on top of USB connectors. The right hand side LED indicates link mode, it lights in orange whenever linking to network. The left hand side LED indicates the transfer mode and it lights in green when data is transferring in 100Mbps (never lights while in 10Mbps), but lights in orange when transferring in Gigabit's mode. To enable or disable this function, you may simply adjust it through BIOS.

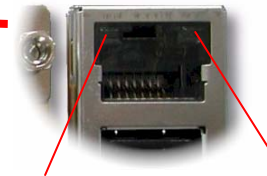
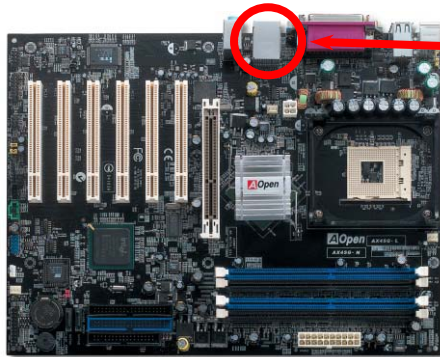

**Transferring (Left)**  
**Green 100Mbps**  
**Orange Gigabit**

**Linking (Right)**  
**Orange**





## Support Eight USB2.0 Connectors

Compared to traditional USB 1.0/1.1 with the speed of 12Mbps, USB 2.0 has a fancy speed up to 480Mbps, which is 40 times faster than the traditional one. Except for the speed increase, USB 2.0 supports old USB 1.0/1.1 software and peripherals, offering impressive and even better compatibility to customers. On this motherboard, all eight USB connectors support USB 2.0 function. To connect those two headers, you have to use proper USB cables and connect them to any USB models.

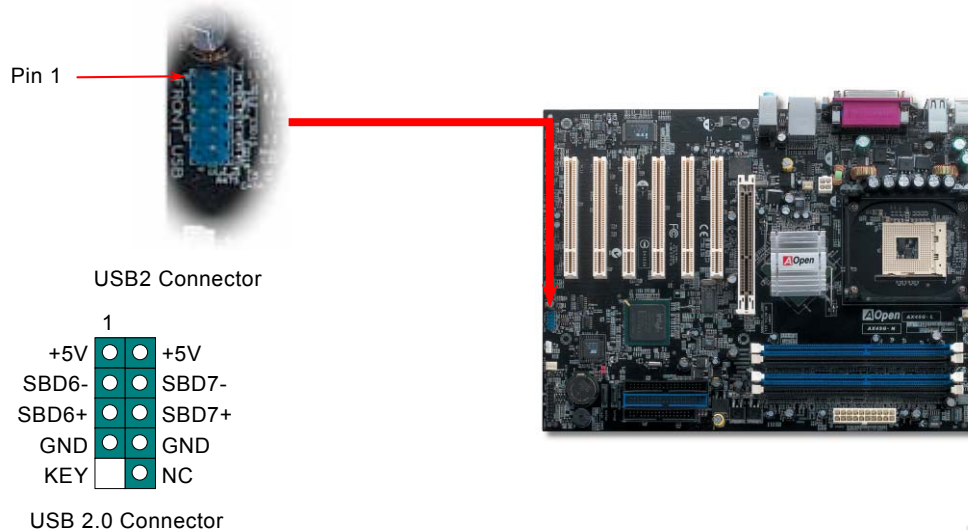

## COM2 Connector

This motherboard provides two serial ports. One of them is on back panel connector, and the other is on the upper left of board. With proper cable, you can connect it to the back panel of chassis.

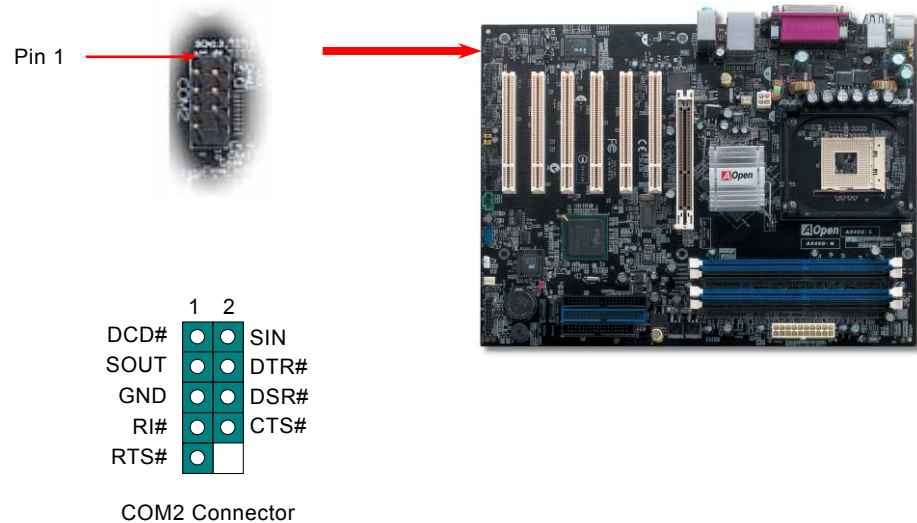

## Game Port Bracket Supported

This motherboard comes with a game port (Joystick-Midi) for you to connect any midi devices or joysticks. To use this function you have to have a joystick module and connect it with a game port cable to this port on the motherboard.

Joystick Module  
(User Upgrade Optional)



Pin1



Game Port Connector

	1	
+5V	● ●	+5V
JAB1	● ●	JBB1
JACX	● ●	JBCX
GND	● ●	MIDI_TXD
GND	● ●	JBCY
JACY	● ●	JBB2
JAB2	● ●	MIDI_RXD
+5V	● □	KEY

Note: This picture is for example only; it may not exactly look the same with the motherboard you purchased.

## Chassis Intrusion Connector

The “CASE OPEN” header provides chassis intrusion-monitoring function. To make this function works, you have to enable it in the system BIOS, connect this header to a sensor somewhere on the chassis. So, whenever the sensor is triggered by lights or the opening of the chassis, the system will send out beep sound to inform you. Please be informed that this useful function only applies to advanced chassis, you may purchase an extra sensor, attach it on your chassis, and make a good use of this function.

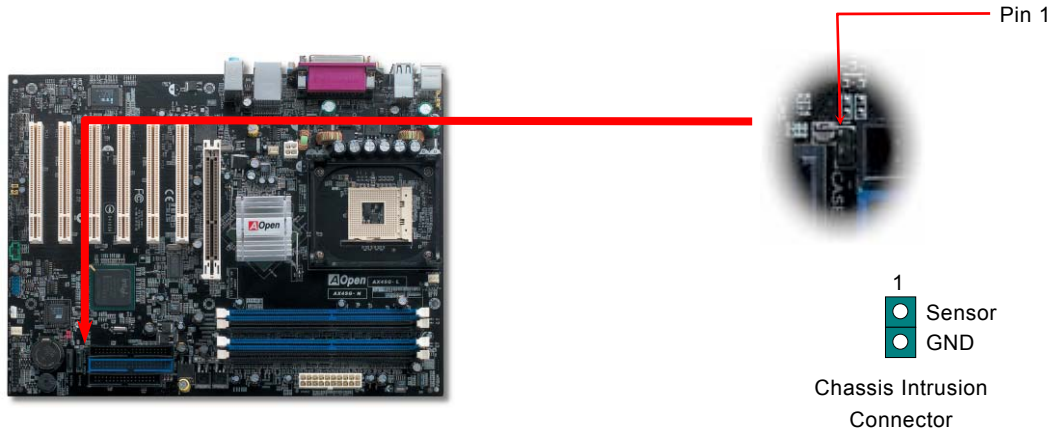

## CD Audio Connector

This connector is used to connect CD Audio cable from CDROM or DVD drive to onboard sound.

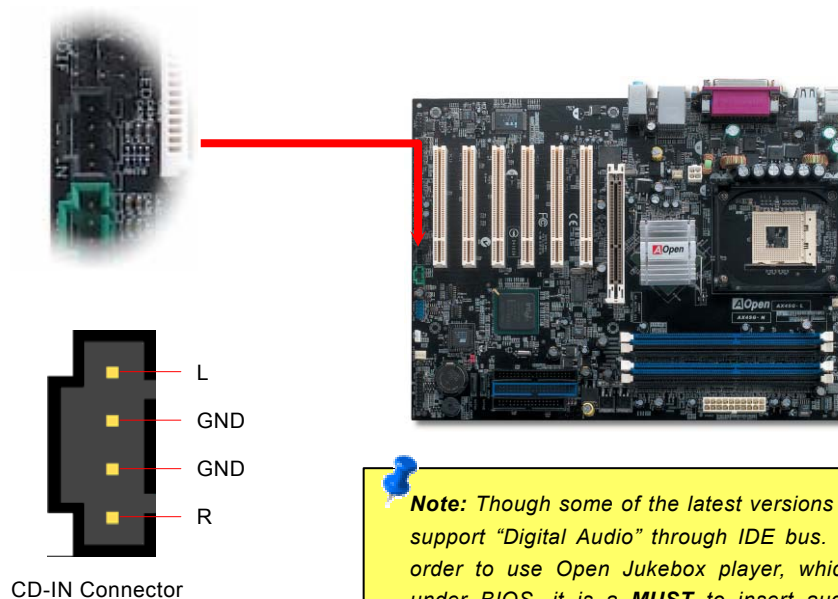

## AUX-IN Connector

This connector is used to connect MPEG Audio cable from MPEG card to onboard sound.

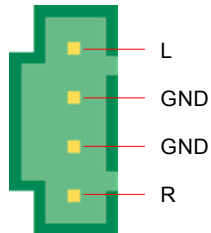
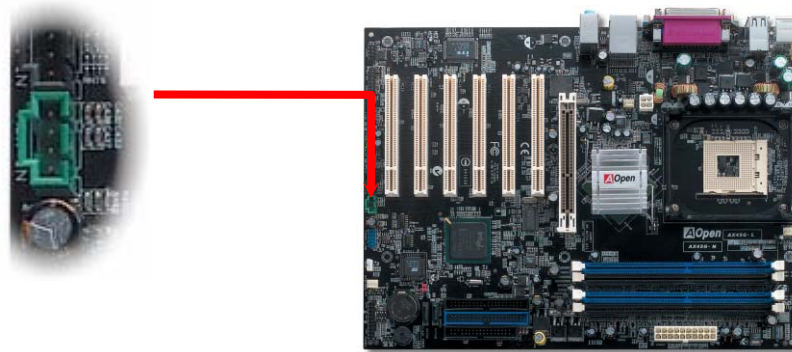

AUX-IN Connector

## Front Audio Connector

If the housing has been designed with an audio port on the front panel, you'll be able to connect onboard audio to front panel through this connector. By the way, please remove 5-6 and 9-10 jumper caps from the Front Audio Connector before connecting the cable. Please do not remove these 5-6 and 9-10 yellow jumper caps if there's no audio port on the front panel.

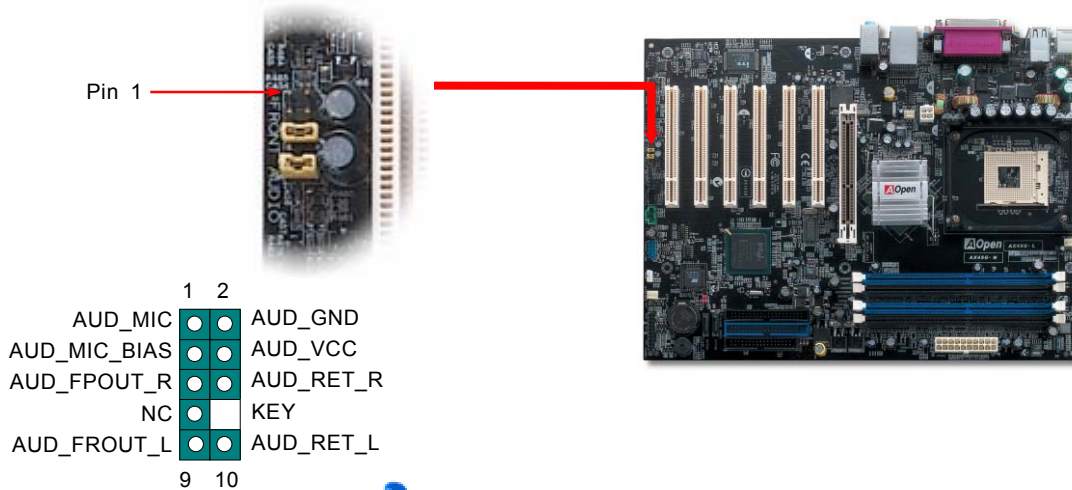

**Note:** Please remove the jumper cap from the Front Panel Audio Connector before you connect the cable. Do not remove this yellow jumper cap if housing without an audio port on the front panel.



## Dr. LED Connector

In conjunction with Dr. LED (Upgrade Optional), which can easily shows what kind of problems may occur on your system during assembly. It can clearly indicate whether there is a component issue or an installed issue by the 8 LED on the front panel of Dr. LED. This can help you to have a self-diagnostic to your system status quickly.

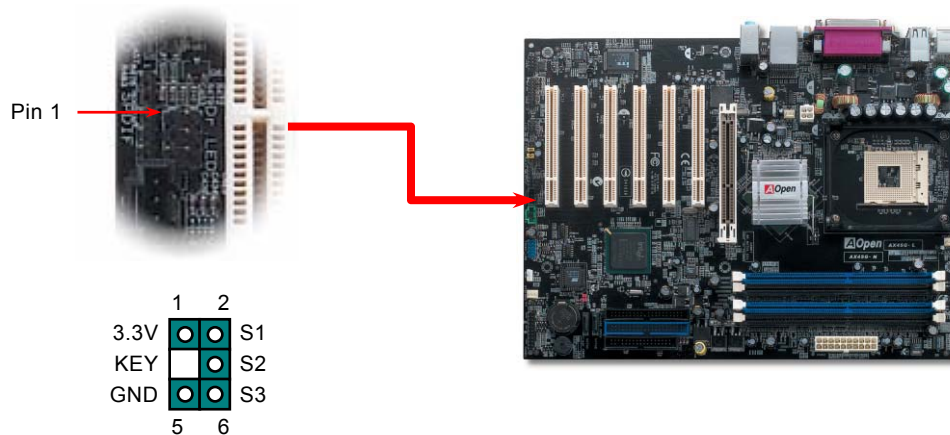

Dr. LED is a CD disc storage box with 8 LED on its front panel, the size of Dr. LED is exactly the same as 5.25 in floppy drive, so that it can be mount into normal 5.25 in drive bay of any housing. This module is User Upgrade Optional.

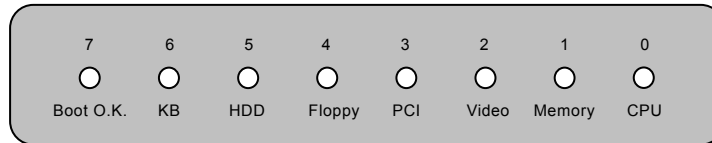

The total 8 LED light up alternatively if the system fails in one of eight stages. Once the LED7 (latest LED) is lit, this indicates that the system has completed its boot-up procedure.

The 8 LED indicate the following messages when lit:

LED 0 - Indicates that the CPU may have been installed incorrectly or is damaged.

LED 1 - Indicates that the memory may have been installed incorrectly or is damaged.

LED 2 - Indicates that the AGP may have been installed incorrectly or is damaged.

LED 3 - Indicates that the PCI card may have been installed incorrectly or is damaged.

LED 4 - Indicates that the floppy disk drive may have been installed incorrectly or is damaged.

LED 5 - Indicates that the HDD may have been installed incorrectly or is damaged.

LED 6 - Indicates that the keyboard may have been installed incorrectly or is damaged.

LED 7 - Indicates that the system is OK.

**Note:** During POST (Power On Self Test) procedure, the Debug LED will light on sequentially from LED0 to LED7 until the system boot O.K

AOConfig Utility



AOConfig

AOpen always dedicated to provide users a much friendlier computer environment. We now bring you a comprehensive system detective utility. AOconfig is a Windows based utility with user-friendly interface that allows users to obtain information of the operation system and hardware such as motherboard, CPU, memory, PCI devices and IDE devices. The powerful utility also displays the version of BIOS and firmware for your convenience of maintenance.

Moreover, AOconfig allows users to save information in \*.BMP or \*.TXT format which users may collect the system information in detail and send them to AOpen directly for technical support or further diagnosis of system problem.

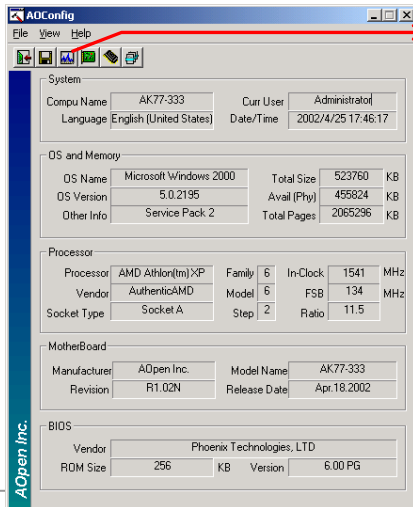

1. The system page shows the detail information of the motherboard, the operating system, the processor, and BIOS version.

2. The PCI device page shows the configurations of all PCI devices installed on your motherboard.

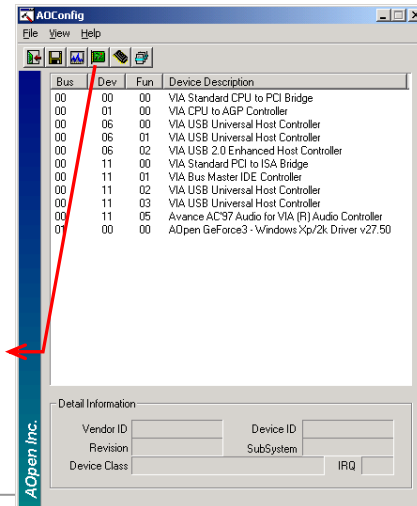

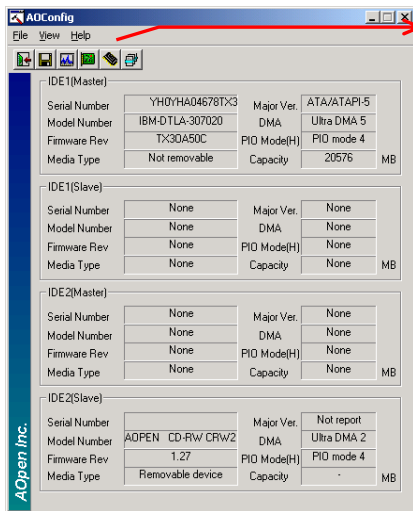

3. This page presents the IDE devices information, such as the serial number, the manufacturer, the firmware version, and capacity.

4. From this page, users may obtain the technical support information of AOpen. Moreover, detailed information could be saved in .bmp or .txt format.

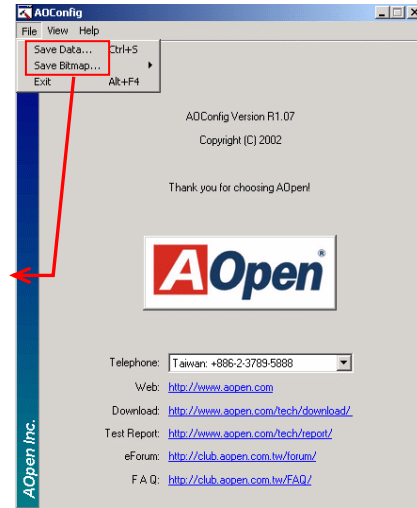

**NOTE:** AOconfig can be used in Windows 98SE/ME, NT4.0/2000, or Windows XP. Please be informed that AOconfig can only be operated in a system equipped with an AOpen motherboard. Meanwhile, all applications must be closed before starting AOconfig.



## Resettable Fuse

Traditional motherboard has fuse for Keyboard and [USB](#) port to prevent over-current or shortage. These fuses are soldered onboard that when it is broken (function as protecting the motherboard), user still cannot replace it and the motherboard is still malfunctioning.

With expensive Resettable Fuse, the motherboard can be resumed back to normal function after the fuse had done its protection job.



## 3300 $\mu$ F Low ESR Capacitor

The quality of low ESR capacitor (Low Equivalent Series Resistance) during high frequency operation is very important for the stability of CPU power. The idea of where to put these capacitors is another know-how that requires experience and detail calculation.

Not only that, AX4SG / AX4SG-N / AX4SG-L implements 3300  $\mu$ F capacitors, which is much larger than normal capacitor (1500 and 2200  $\mu$ F) and it provides better stability for CPU power.

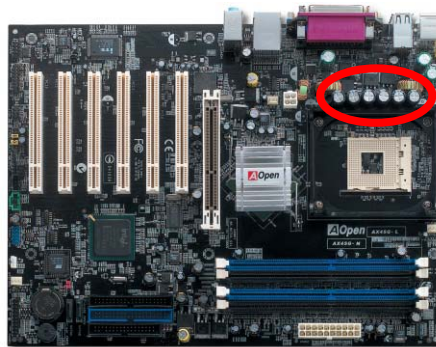

The power circuit of the CPU core voltage must be checked to ensure system stability for high speed CPUs (such as the new Pentium III, or when overclocking). A typical CPU core voltage is 2.0V, so a good design should control voltage between 1.860V and 2.140V. That is, the transient must be below 280mV. Below is a timing diagram captured by a Digital Storage Scope, it shows the voltage transient is only 143mV even when maximum 60 current is applied.

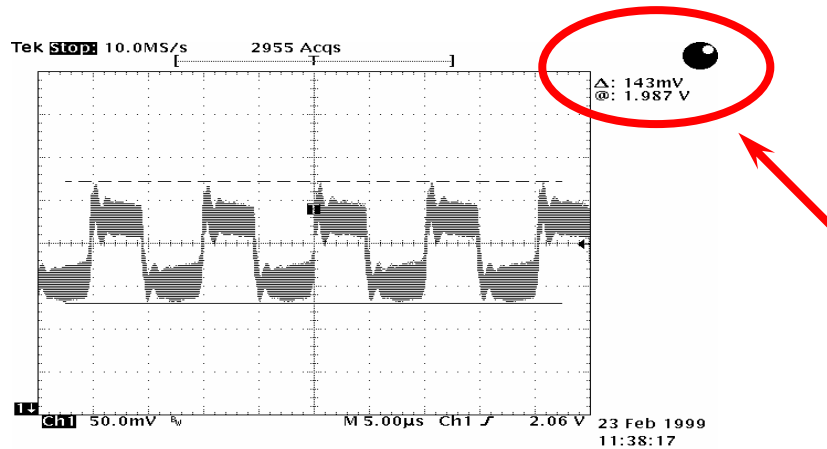

Note: This diagram for example only, it may not exactly be the same motherboard.

## **Enlarged Aluminum Heatsink**

Cool down CPU and Chipset is important for system reliability. Enlarged aluminum heat sink provides better heat consumption especially when you are trying to over clocking the CPU.

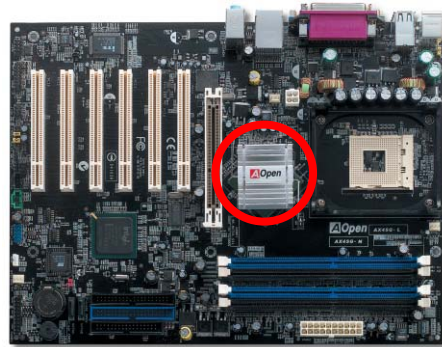





## Open JukeBox Player



JukeBox

Here we are pleased to provide you a brand-new powerful interface—Open JukeBox. Without any cost you can have your PC turn into a fashionable CD player! This latest Open JukeBox motherboard aims at helping you directly operate your CD player on the PC without any hassle of entering Windows operation system.



### How Your Open JukeBox Works

The operation of Open JukeBox Player is the same as other CD players. By pressing specific keys on the keyboard you will find playing Open JukeBox Player couldn't be easier than the traditional CD Players. Below is the function description of respective buttons.



- Power:** Pressing **O**, to directly power off your computer with no hassle of entering Windows Operation System.
- Boot:** Pressing **B**, to intelligently boot to Windows Operation System for you.
- Play:** Pressing **A**, to start playing CD music.
- Stop:** Pressing **S**, to stop the music playing.
- Pause:** Pressing **P**, to pause the music playing temporarily.
- Eject:** Pressing **E**, to eject CD tray for you to change CD disc.
- Repeat:** Like other CD Players, pressing **R**, to shift the repeat mode.
- Volume +/-:** Pressing **+** or **-** to adjust the volume of playing music.
- Rewind/Forward** **← / →**: Pressing **arrow keys**, to rewind or forward the music.

**Note:** Though some of the latest version of Windows support "Digital Audio" through IDE bus. However, in order to use Open Jukebox player, which is driven under BIOS, it is a **MUST** to insert audio cable to CD-IN connector on the motherboard.

## Your Open JukeBox Settings in BIOS

There are three Open JukeBox settings in BIOS as follows.

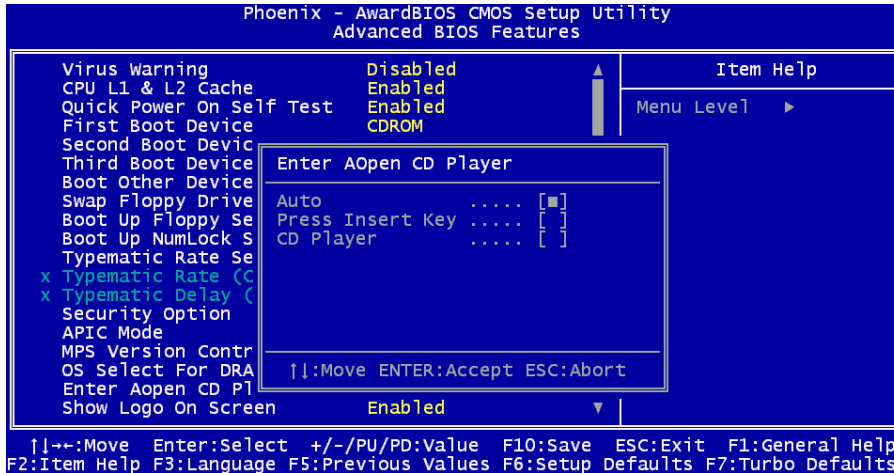

**Auto:** The default setting is “Auto” with which the Open JukeBox will automatically check the CD player every time you power on. The Open JukeBox will automatically be launched when it detects a music CD in your CD player.

**Press Insert Key:** Choosing this setting will allow a reminder message popped up on the screen during BIOS POST. It reminds you of pressing “Ins” key on your keyboard to start Open JukeBox Player; otherwise the system will launch the Windows Operation System.

**CD Player:** Choosing this setting allows the system to launch Open JukeBox Player every time you power on. However, by pressing **B** on your keyboard the Windows Operation System will be launched.



## Your Open JukeBox EzSkin



Except these powerful functions above, Open JukeBox Player is also equipped with another fancy feature for you to change its “skin”. You can download as many skins as you want from AOpen Website, and changing them whenever you want by using this useful utility – **EzSkin** – which may also be downloaded from our website.

Even more, you may design your own skins with innovative idea and sharing them to users around the world by uploading to our website. For further technical information, we welcome you to visit our website at <http://english.aopen.com.tw/tech/download/skin>



## Vivid BIOS technology



Have you been fed up with the conservative and immutable POST screen? Let's rule out the tradition idea that POST screen are stiff and frigid, and let AOpen show you the newly developed VividBIOS to experience the lively vivid colorful POST screen!

Unlike earlier graphic POST screen which could occupy the whole screen and mask text information during POST, AOpen VividBIOS deals with graphics and texts separately, and makes them running simultaneously during POST. With this innovative design, VividBios now brings you a beautiful and sleek 256 colors screen without missing any important information shown on POST screen.

In addition, the limited space of BIOS ROM is another big issue. When all of the traditional BIOS can only show space-consuming and uncompressed Bitmap, AOpen has considerably tuned the BIOS to next generation, to recognize the smaller-sized GIF format and even dynamic-showing GIF animation.



Vivid BIOS shares the same fundamental technology with Open JukeBox CD Player, you may use the same EzSkin utility to

change your Vivid BIOS screen or to download your favorite Open JukeBox skin. If you see this little logo  shown beside your model name on the BIOS download page, <http://english.aopen.com.tw/tech/download/skin>, it is assured that your motherboard supports this innovative feature!

The noise is gone!! ---- SilentTek



As the clock of CPU keeps rocketing higher and higher, it inevitably brings higher heat and system temperature in a relative way. The way we deal with this heat problem, however, is to spare no effort to add one fan after another to protect our pampered system, expecting these fans could cool down our machine as much as they could.

But at the same time, we believe that same users are affected terribly by the irritating noises of these fans while working with

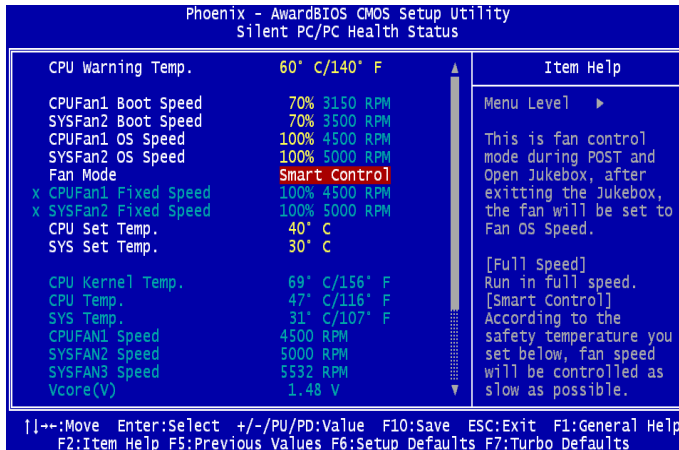

their PC. As a matter of fact, we do not have to get our fans running at such a high speed in most cases; on the contrary, we discovered that having your fans running at appropriate time and speed not only reduces the noise, but also consumes the least power the system needs, so as to prevent over-wasting of energy resource.

Today, AOpen Motherboard is honored to bring you a new overall solution, SilentTek, to make your system quiet. To collocate with hardware circuit, BIOS and the utility under Windows, SilentTek combined “Hardware-Status Monitoring”, “Overheat Warning” and “Fan Speed Control” with user-friendly interfaces to provide you a perfect balance among noises, system performance and stability.



The first image you have here is the Voltage Status page. You can find current status of all voltages and set your expected margins of warning level.

In “Temp/Fan/Case” page, you may get aware of the current temperature of CPU and the heat inside chassis. Also, you can check if fans are running properly.

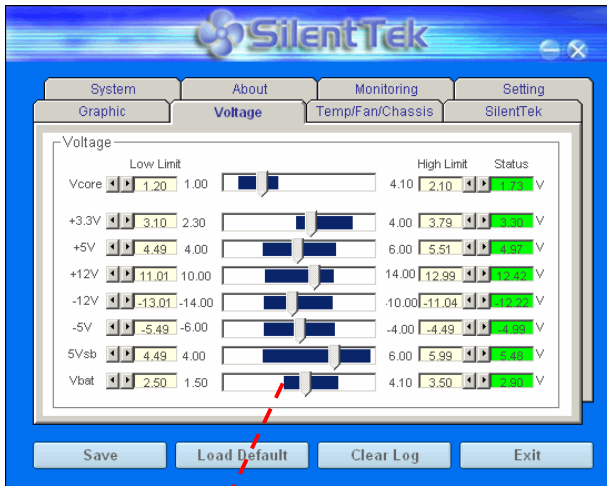

You may check your system voltage from the indicating bar here.

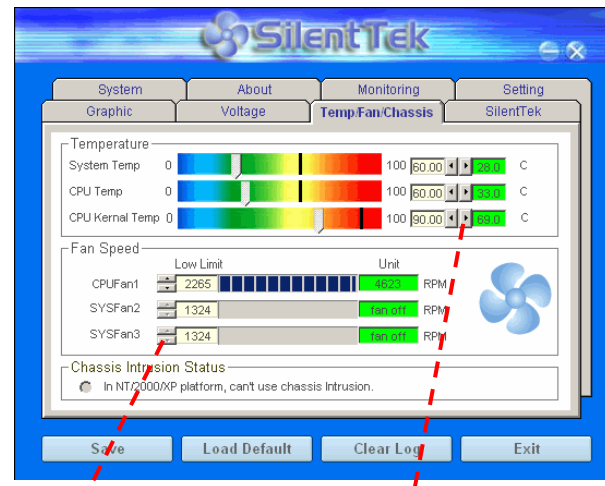

Of course, you may set your defaulted lowest margin for your fans and SilentTek would also pop up a message box to alarm you when the fan is rotating slower than this specified speed.

You may set the highest margin of your CPU and system temperature as default, and SilentTek would pop up a message box to alert you with alarm when the temperature goes beyond the specified margin.

The following page is surely the most important part of this utility. You may control the rotation speed of specific fans that you have got the options inside in this page.

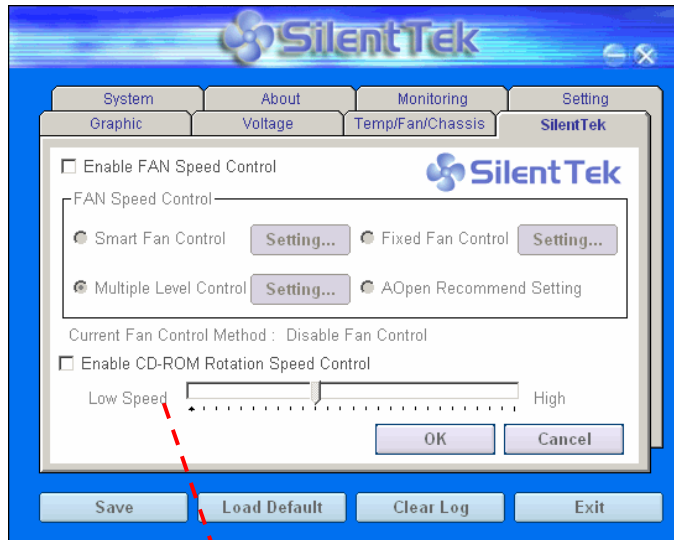

**CD-ROM Rotation Speed Control:** by enabling the CD-ROM Rotation Speed Control, you can adjust the rotation speed of your CD-ROM. When you set the speed to high level, the CD-ROM will work at its fastest speed and it will run at basic required speed while you set the value to low speed.

1. **Smart FAN Control:** This is the default setting of SilentTek and can be used for any branded computer housing. With a special algorithm developed by AOpen, the fan speed is automatically adjusted by the factors of CPU and ambient temperature. Ease-of-use and trouble free at your service.
2. **Fixed FAN Control:** Under this setting, a desired fan speed is set fixed when operating.
3. **Multiple Level Control:** This is the most versatile setting that allows you to set fan speed in relation to temperature. You may find that this setting fits you best.
4. **AOpen Recommend Setting:** This setting is designed specifically for AOpen housing. A series of lab tests were conducted under the real world scenario to determine optimum fan speed to reduce noise level within CPU working condition and temperature. Most of the time, the fan would remain still when CPU is not fully utilized.

**Note:** Due to hundreds different brands of fan on the market, inaccuracy may happen in some cases when you had your rotation speed adjusted. It is still under the criterion and please rest assured that it won't cause any problem to your system.



## EzClock



Have you ever thought how great it would be if you can adjust the frequency setting on your motherboard under Windows environment and be a real master of your system? Everybody knows that the ratio and frequency setting are key factors to influence the system performance, however, it's absolutely not an easy task for an amateur to adjust the setting value. On most traditional motherboards, you have to get into BIOS screen for the frequency and reboot the system again and again. But from now on, you don't have to surfer the boring stuffs anymore.

With brand-new and user-friendly EzClock that AOpen specially designs for his users, you can adjust those important values as you please and think of suitable. This tailor-made EzClock allows you to set the voltage and frequency of CPU, VGA, PCI and memory under Windows environment as well as in BIOS setting page; even better, those settings will be displayed realtime. Having this handy EzClock, you can monitor the system when you're fine-tuning the performance of your system. It provides you detailed and necessary information. Now let's take a look how it works on utility, BIOS and POST.



## How You Adjust the Settings in EzClock Utility

In EzClock utility, you can adjust CPU Front Side Bus (FSB), the voltage and frequency of VGA, AGP, PCI and DRAM. Besides, the CPU related information such as CPU voltage, temperature and CPUFAN rotation speed will also be displayed on this utility.

### CPU Color Bars:

The color bar will light on and show different colors as values change. On default values, it will show green.



On the left circle area shows Ratio, FSB and frequency information about CPU. When the values are set to factory default, the light on the top and bottom of the circle will show green and it will vary as you change these CPU settings.

### CPU Ratio, FSB and frequency displaying area:

You can adjust CPU FSB here by entering preferred value.

On the right part of the panel is the section that you adjust the settings of VGA, AGP, PCI and memory. To adjust the voltage and clock frequency of those installments, you can press “-” or “+” on corresponding items. The color parts represent the situation of values. The higher value you set, the light on the color bar goes to right and turns red. After finishing those value settings, you can press “S” button on the upper right hand corner to save changes to CMOS.

### VGA, AGP, PCI and DRAM Voltage / Clock Area:

Pressing “-” and “+” buttons, you can adjust the voltage and clock frequency values of onboard VGA, AGP, PCI and DRAM.

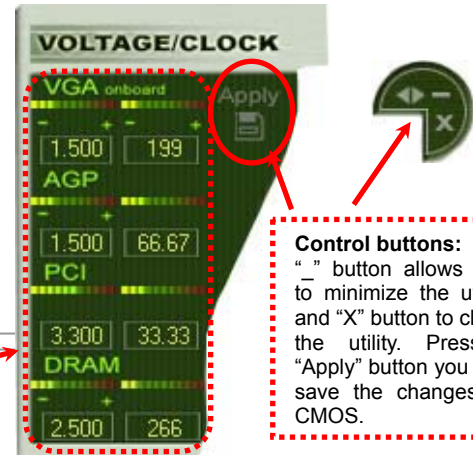

### Control buttons:

“-” button allows you to minimize the utility and “X” button to close the utility. Pressing “Apply” button you can save the changes to CMOS.

On the bottom rectangular panel represents CPU fan speed, CPU voltage and CPU temperature. The three color bars on the right hand side will light on according to operation temperature. Please refer to the picture shown above.

**CPU Color Bars:**

The color bars will light on according to CPU operation temperature.



**CPU Fan, Voltage and Temperature:**

representing CPU fan speed, CPU voltage and CPU temperature in Celsius and Fahrenheit degrees.

**How You Adjust the Settings in BIOS**

Apart from EzClock utility, the voltage and frequency values of CPU, PCI and memory can also be adjusted on BIOS page. By pressing

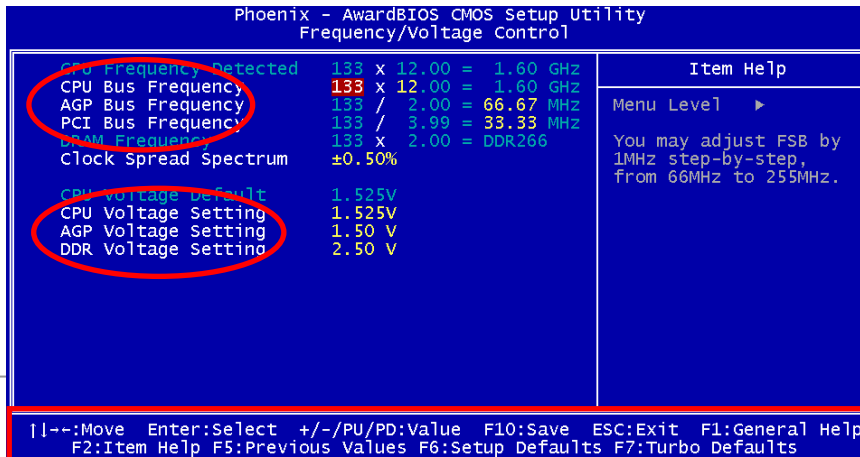

“+”, “-”, “PgUp” or “PgDn” keys, you can adjust the frequency values of CPU Bus, PCI Bus and DRAM.

Also, the same keys help you adjust the voltage of CPU and DDR settings. Some values may change while you adjust the settings. You can press “F10” to save the changes you’ve made.

Function Keys Description



How Your Boot Screen Looks Like

After you finish setting BIOS, these setting values will be displayed on the boot screen like the shown picture here.

Every time you boot your system, both default and current settings will pop up on the screen. Your personal settings that had been adjusted earlier will be highlighted; thus, you can have clear idea how your system functions and monitor your system more easily.

Current values of your system

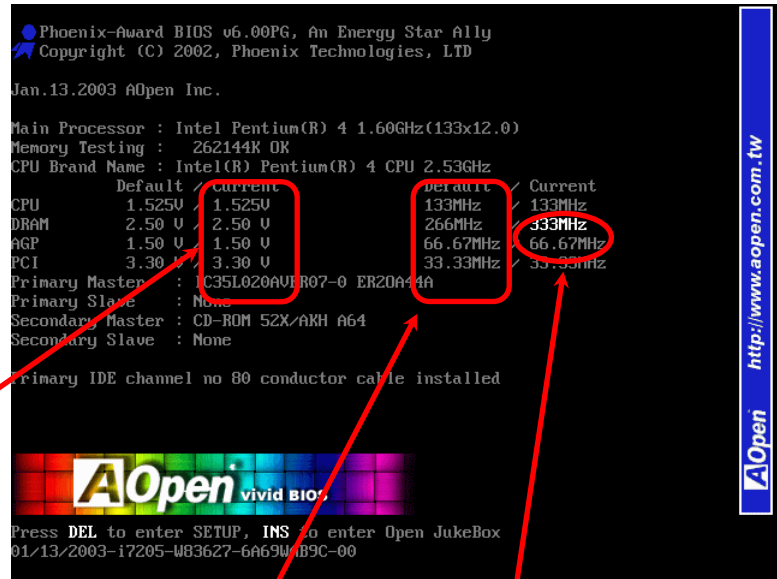

Default settings of this motherboard

The highlighted setting value you manually



## Hyper Threading Technology

### What is Hyper-Threading?

Hyper-Threading technology is an innovative design from Intel that enables multi-threaded software applications to process threads in parallel within each processor resulting in increased utilization of processor execution resources. As a result, an average improvement of ~40% in CPU resource utilization yields higher processing throughput.

### How Hyper-Threading Works

A form of simultaneous multi-threading technology (SMT), Hyper-Threading technology allows multiple threads of software applications to be run simultaneously on one processor by duplicating the architectural state on each processor while the same processor execution resources is shared.

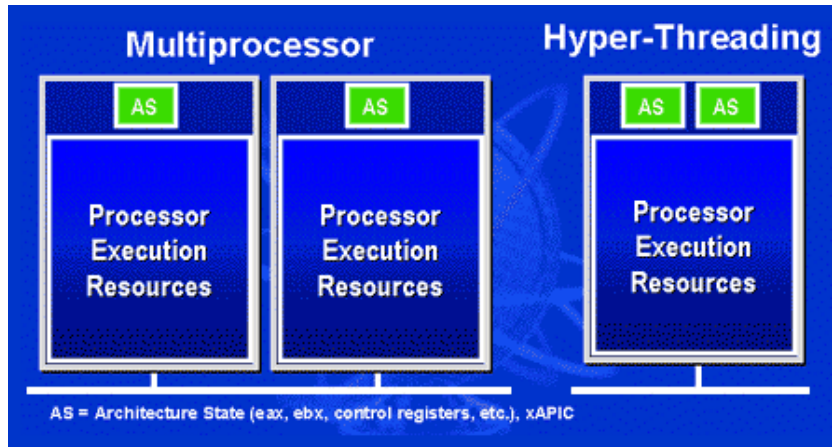

while the same processor execution resources is shared. The figure below represents how a Hyper-Threading based processor differentiates a traditional multiprocessor. The left-hand configuration shows a traditional multiprocessor system with two physical processors. Each processor has its own independent execution resources and architectural state. The right-hand configuration represents an Intel Hyper-Threading technology based processor. You can see that the architectural state for each processor is duplicated, while the execution resources is shared.

processor. You can see that the architectural state for each processor is duplicated, while the execution resources is shared.



For multiprocessor-capable software applications, the Hyper-Threading based processor is considered two separate logical processors on which the software applications can run without modification. Also, each logical processor responds to interrupts independently. The first logical processor can track one software thread, while the second logical processor tracks another software thread simultaneously. Because the two threads share the same execution resources, the second thread can use resources that would be otherwise idle if only one thread was executing. This results in an increased utilization of the execution resources within each physical processor.

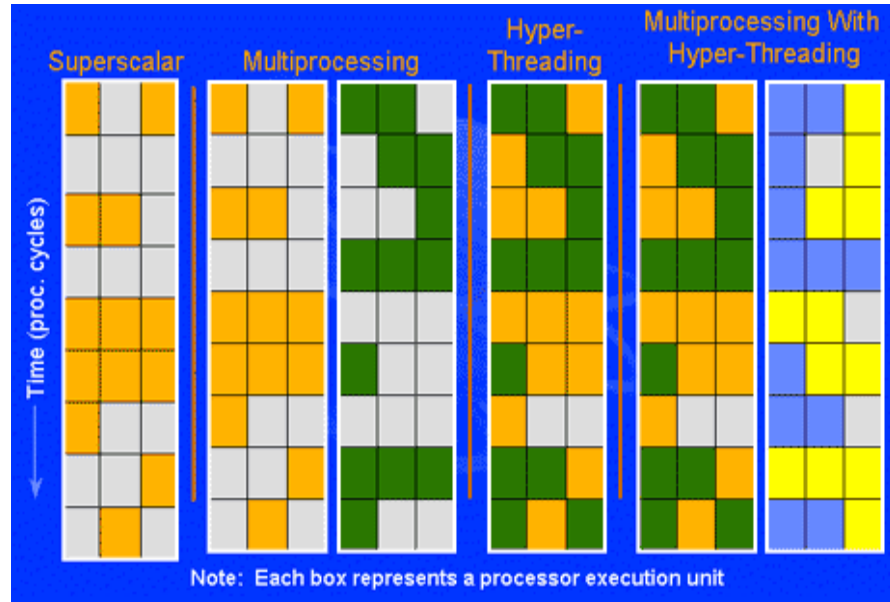

The figure below represents how Hyper-Threading saves time when it works. With two logical processors available on every single physical processor, multi-threaded applications can now take advantage of thread-level parallelism on each physical processor for additional performance. As software applications continue to be optimized to take greater advantage of processor parallelism, Hyper-Threading technology provides an additional boost for newer capabilities and the growing needs of today's users.



# Driver and Utility

There are motherboard drivers and utilities included in AOpen Bonus CD disc. You don't need to install all of them in order to boot your system. But after you finish the hardware installation, you have to install your operation system first (such as Windows XP) before you can install any drivers or utilities. Please refer to your operation system's installation guide.

## Auto-run Menu from Bonus CD Disc

You can use the auto-run menu of Bonus CD disc. Choose the utility and driver and select model name.

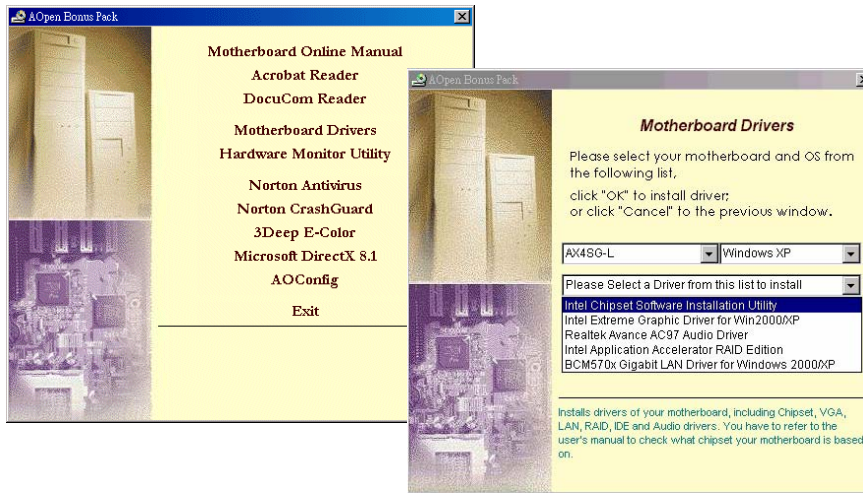

## Installing Intel® Chipset Software Installation Utility

The Intel® Chipset Software Installation Utility should be installed onto the target system and the Windows \* INF files outline the operating system how the chipset components will be configured. It is recommended that the Intel® Chipset Software Installation utility be installed onto the target system prior to the installation of other drivers.

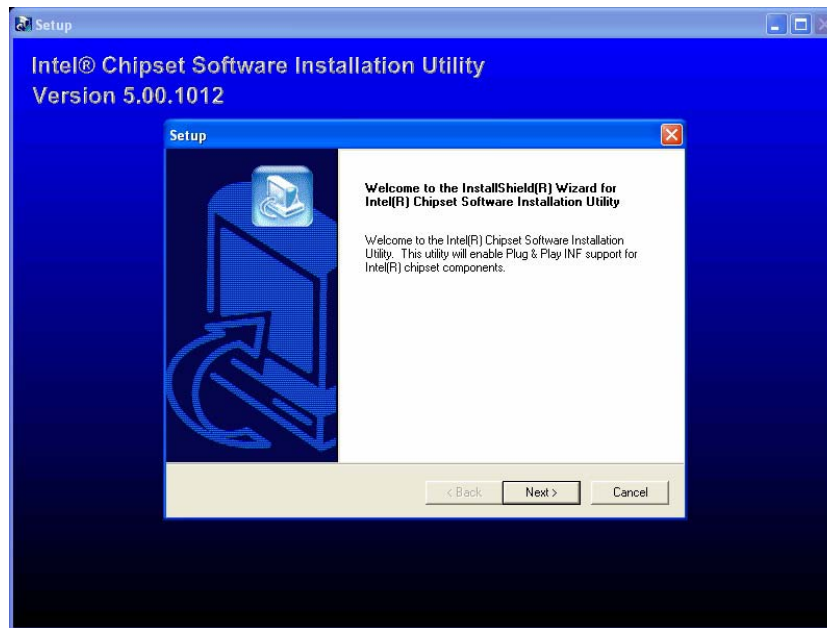



## **Intel Brookdale-G VGA driver**

You can install Intel VGA Driver to get the best graphics function of the chipset. You can find this driver from the Bonus Pack CD auto-run menu.

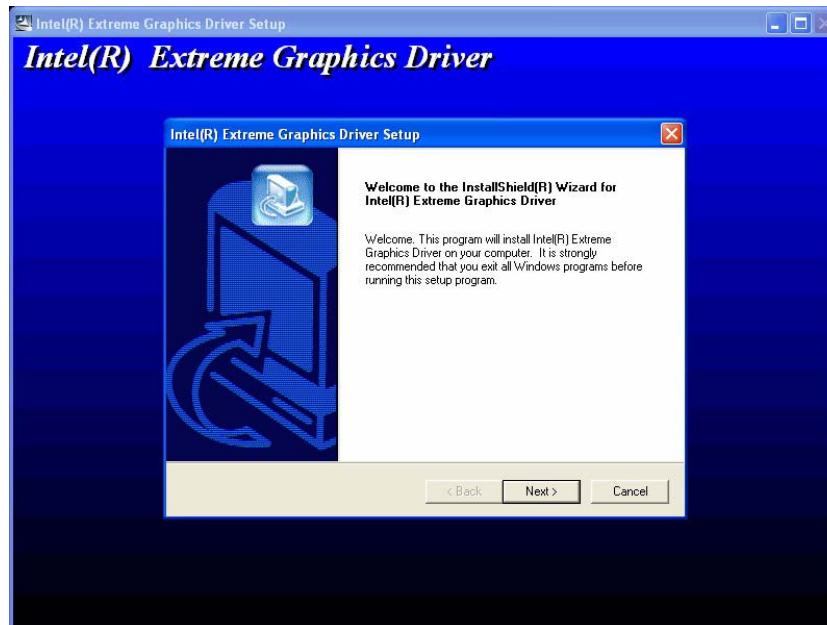

## Installing Intel IAA Driver RAID Edition

You can install Intel IAA Driver to increase the performance of software applications, reduce PC boot times and add support for RAID. Here the IAA Driver RAID Edition Driver only supports Windows XP. You can find the driver from the Bonus Pack CD auto-run menu.

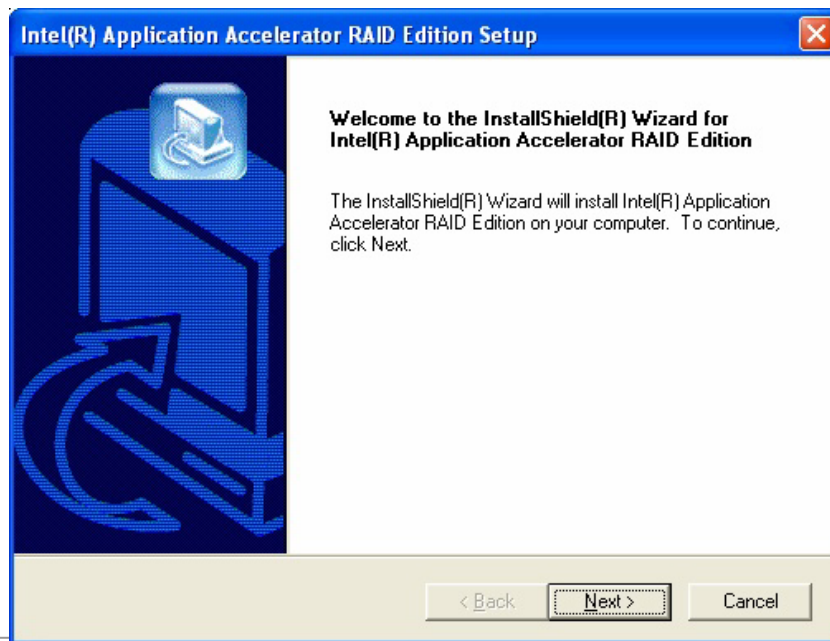

## **Installing Onboard Sound Driver**

This motherboard comes with [AC97 CODEC](#). This audio driver supports Windows 98SE and upper Windows OS; you can find the audio driver from the Bonus Pack CD auto-run menu.

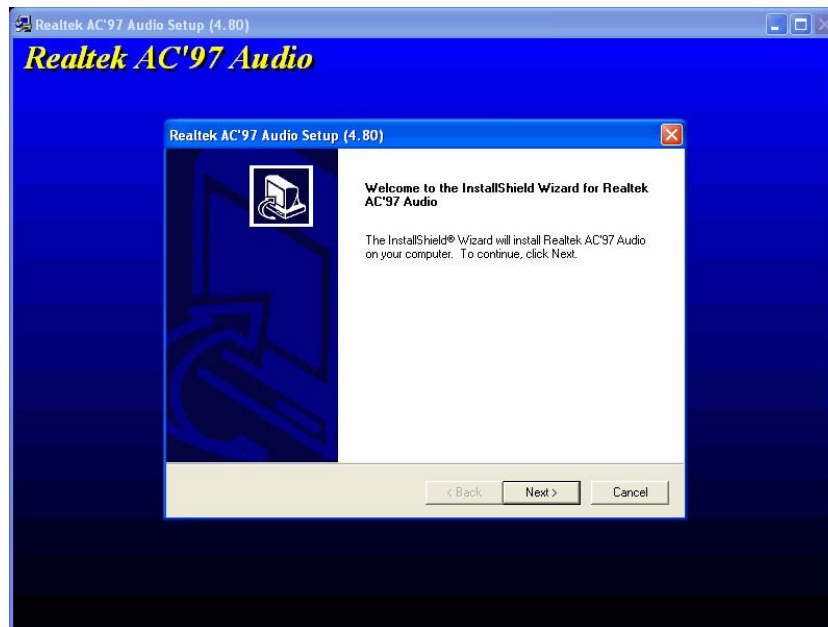

## **Installing USB 2.0 Driver**

\*Windows 98SE Installation Guide

\*\*\*\*\*

Installing Drivers with Existing Windows 98SE

\*\*\*\*\*

The following section details the installation of USB 2.0 driver on a system that has Windows 98SE already installed.

1. Enable the USB 2.0 controller and boot Windows.
2. The "Add New Hardware Wizard" will appear, informing you that it has found a "PCI Universal Serial Bus."
3. Click on "Next," and from the generated list box, choose "Search for best driver for your device (Recommended)".
4. Insert the "Bonus CD" in CD-ROM.
5. Click on "Next," and from the generated choices, choose "Specify a location."
6. Type "[CD-ROM]:\Driver\Inte\USB2.0\Win98ME" in the text box that appears.
7. Click on "Next." A message informing you that Windows has found "Intel USB 2.0 Enhanced Host Controller" should appear.
8. Click on "Next," and then on "Finish."

\*\*\*\*\*

Confirming Driver Installation in Windows 98SE

\*\*\*\*\*

To confirm that the driver has been properly loaded in Windows 98SE, perform the following steps:

1. Choose "Settings" from the "Start" menu.
2. Choose "Control Panel," and then double-click on the "System" icon.



3. Choose the "Device Manager" tab, and then click the "+" in front of "Universal Serial Bus Controllers." "Intel USB 2.0 Enhanced Host Controller" should appear.

\* Windows 2000 Installation Guide

\*\*\*\*\*  
Installing Driver in Existing Windows 2000 System  
\*\*\*\*\*

After enabling the USB 2.0 controller and rebooting your system, Windows 2000 setup will show a "New Hardware Found" dialog box. Under Windows 2000, "Universal Serial Bus (USB) Controller" will be displayed.

1. Choose "Search for a suitable driver for my device (Recommended)". from the list, and then press "Enter".
2. Choose "Specify a location." and then press "Next"
3. Insert the Bonus CD in CD-ROM.
4. Type "[CD-ROM]:\Driver\Intel\USB2.0\Win2000" in the text box that appears. Press " OK ".
5. Click on "Next." A message informing you that Windows has found "Intel PCI to USB Enhanced Host Controller - ICH5" should appear.
6. Click on "Next," and then on "Finish."

\*\*\*\*\*  
Confirming Windows 2000 Installation  
\*\*\*\*\*



1. From Windows 2000, open the Control Panel from "My Computer" followed by the System icon.
2. Choose the "Hardware" tab, and then click the "Device Manager" tab.
3. Click the "+" in front of "Universal Serial Bus controllers". "Intel PCI to USB Enhanced Host Controller - ICH5" should appear.

\*Windows Me Installation Guide

\*\*\*\*\*  
Installing Drivers with Existing Windows Me System  
\*\*\*\*\*

The following section details the installation of USB 2.0 driver on a system that has Windows Me already installed and running.

1. After installing the USB 2.0 controller, boot system.
2. The "Add New Hardware Wizard" will appear, informing you that it has found a "PCI Universal Serial Bus."
3. Click on "Next," and from the generated list box, choose "Specify the location of the driver (Advanced)."
4. Click on "Next," and from the generated choices, choose "Specify a location."
5. Insert the Bonus CD in CD-ROM.
6. Type "[CD-ROM]:\Driver\Intel\USB2.0\Win98ME" in the text box that appears.
7. Click on "Next." A message informing you that Windows Me has found "Intel USB2.0 Enhanced Host Controller" should appear.
8. Click on "Next," and then on "Finish."

\*\*\*\*\*  
Confirming Driver Installation in Windows Me  
\*\*\*\*\*



To confirm that the driver has been properly loaded in Windows Me, perform the following steps:

1. Choose "Settings" from the "Start" menu.
2. Choose "Control Panel," and then double-click on the "System" icon.
3. Choose the "Device Manager" tab, and then click the "+" in front of "Universal Serial Bus Controllers." "Intel USB2.0 Enhanced Host Controller" should appear.

## **Installing LAN Driver (for AX4SG-N)**

In Windows 2000 and Windows XP, you can find the LAN driver from the Bonus Pack CD disc auto-run menu.

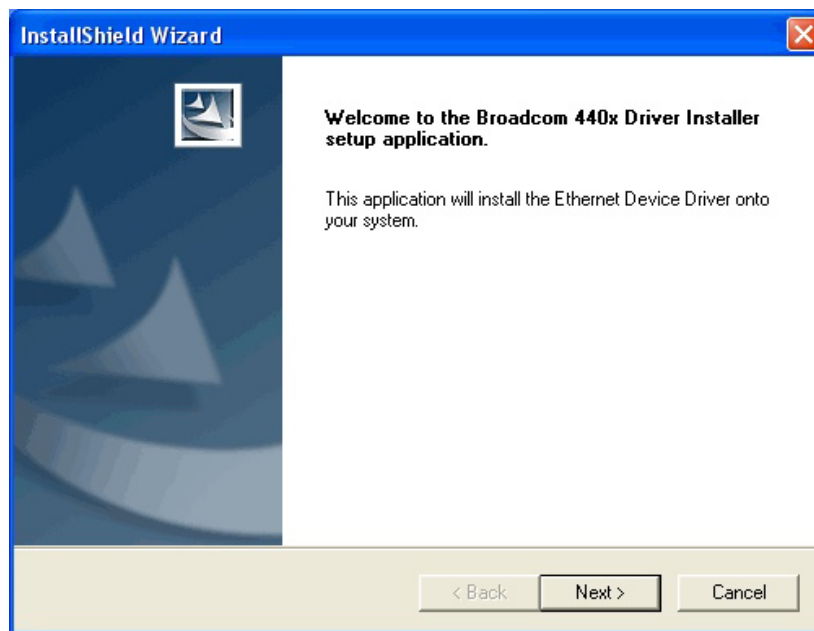



\*\*\*\*\*  
BroadCom Ethernet Driver Install Guide under Win98SE/ME  
\*\*\*\*\*

1. Open the Device Manager and check if there is a "PCI Ethernet Controller" in "Other devices"
2. Insert the supplied "Bonus CD"
3. Click "PCI Ethernet Controller"-> "Driver" -> "Update Driver" and Select "Install the software automatically (Recommended)"  
And then Click "Next".
4. When prompted, insert the media to be searched into your CD-ROM drive, type the path to the driver, and select OK.  
Example: e:\Driver\Lan\BCM4401  
Where "e:\Driver\Lan\BCM4401" is the designation of the driver on your system.
5. In the Driver Files Search Results window, verify that the correct path to the driver software is shown, and then click next.
6. Then OS will request to insert the Bonus CD into CD-ROM Driver
7. Type the path of the BroadCom Ethernet driver and select "OK"  
Example: e:\Driver\Lan\BCM4401  
Where "e:\Driver\Lan\BCM4401" is the designation of the "bcm4sbe5.sys" on your Bonus CD.
8. BroadCom Ethernet driver installation finish

\*\*\*\*\*  
BroadCom Ethernet Driver Install Guide under Windows NT4.0  
\*\*\*\*\*

1. Verify that the Windows NT system is upgraded with Service Pack 4 or later.



2. Start your Windows NT system and log in. You must have System Administrator privileges to install the driver software.
3. Open the Control Panel.
4. In the Control Panel, double-click the Network icon.
5. When the Network window opens, select the Adapters tab.
6. Click "Add" to install a new adapter.

All previously installed drivers are listed under Network Adapters
7. When the Select Network Adapter window opens, click "Have Disk"....
8. When prompted, insert the driver installation media, or choose a location to install the driver from. Type the path to the driver, and click "OK".

For example, to install the adapter driver software for Windows NT, type D:\Driver\Lan\BCM4401 in the Insert Disk location box (where "d:\Driver\Lan\BCM4401" is the designation of the LAN driver on Bonus CD).
9. With "Broadcom 440x 10/100 Integrated Controller" highlighted in the Select OEM Option window, click "OK".

The adapter files are installed, and then the Network window is displayed showing the newly installed adapter.
10. Click "Close", then the Microsoft TCP/IP Properties window appears.
11. Configure the TCP/IP protocol and click "OK".
12. When prompted to restart your computer, click "Yes".

## **Installing LAN Driver (for AX4SG-L)**

In Windows 2000 and Windows XP, you can find the LAN driver from the Bonus Pack CD disc auto-run menu.

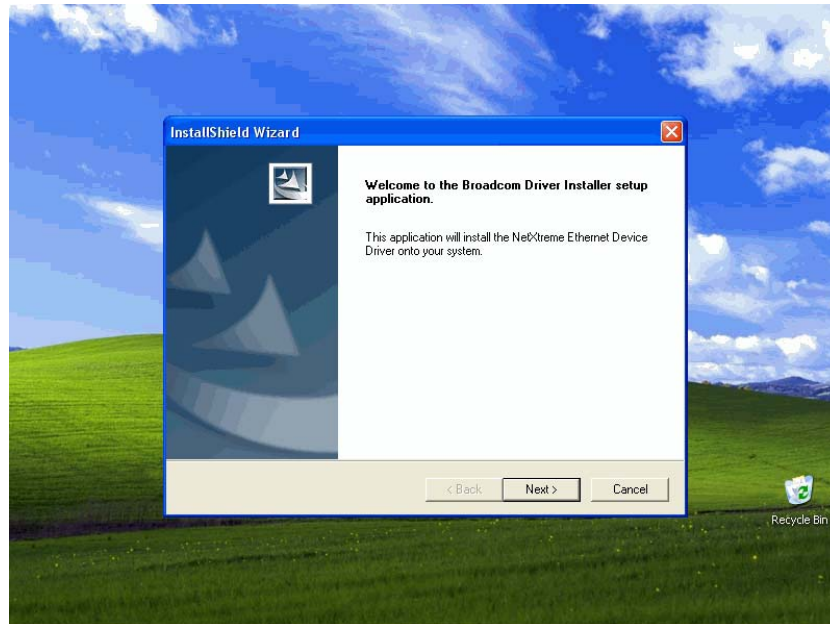

\*\*\*\*\*  
BroadCom Ethernet Driver Install Guide under Win98SE/ME  
\*\*\*\*\*

1. Open the Device Manager and check if there is a "PCI Ethernet Controller" in "Other devices"
2. Insert the supplied "Bonus CD"
3. Click "PCI Ethernet Controller"->"Driver"->"Update Driver" and Select "Install the software automatically (Recommended)"  
And then Click "Next".
4. When prompted, insert the media to be searched into your CD-ROM drive, type the path to the driver, and select OK.  
Example: e:\Driver\Lan\BCM5705  
Where "e:\Driver\Lan\BCM5705" is the designation of the driver on your system.
5. In the Driver Files Search Results window, verify that the correct path to the driver software is shown, then click Next.
6. Then OS will request to insert the Bonus CD into CD-ROM Drive
7. Type the path of the BroadCom Ethernet driver and select "OK"  
Example: e:\Driver\Lan\BCM5705  
Where "e:\Driver\Lan\BCM5705" is the designation of the "b57w2k.sys" on your Bonus CD.
8. BroadCom Ethernet driver installation finish

\*\*\*\*\*  
BroadCom Ethernet Driver Install Guide under Windows NT4.0  
\*\*\*\*\*

1. Verify that the Windows NT system is upgraded with Service Pack 4 or later.



2. Start your Windows NT system and log in. You must have System Administrator privileges to install the driver software.
3. Open the Control Panel.
4. In the Control Panel, double-click the Network icon.
5. When the Network window opens, select the Adapters tab.
6. Click "Add" to install a new adapter.

All previously installed drivers are listed under Network Adapters

7. When the Select Network Adapter window opens, click "Have Disk"....
8. When prompted, insert the driver installation media, or choose a location to install the driver from. Type the path to the driver, and click "OK".

For example, to install the adapter driver software for Windows NT, type D:\Driver\Lan\BCM5705 in the Insert Disk location box (where "d:\Driver\Lan\BCM5705" is the designation of the Lan driver on Bonus CD).

9. With "Gigabit Ethernet Controller" highlighted in the Select OEM Option window, click "OK".

The adapter files are installed, and then the Network window is displayed showing the newly installed adapter.

10. Click "Close", then the Microsoft TCP/IP Properties window appears.
11. Configure the TCP/IP protocol and click "OK".
12. When prompted to restart your computer, click "Yes".

# PHOENIX-AWARD BIOS

System parameters can be modified by going into [BIOS](#) Setup menu, this menu allows you to configure the system parameters and save the configuration into the 128 bytes CMOS area, (normally in the RTC chip or in the main chipset).

The Phoenix-Award BIOS™ that installed in the [Flash ROM](#) of the motherboard is a custom version of an industry standard BIOS. The BIOS provides critical low-level support for standard devices such as hard disk drives, serial and parallel ports.

Most BIOS setting of AX4SG / AX4SG-N / AX4SG-L had been optimized by AOpen's R&D engineering team. But, the default setting of BIOS still can't fine-tune the chipset controlling entire system. Hence, the rest of this chapter is intended to guide you through the process of configuring your system using setup.

To enter to BIOS setup menu, press <Del> when [POST \(Power-On Self Test\)](#) screen is shown on your monitor.



**Note:** *Because the BIOS code is the most often changed part of the motherboard design, the BIOS information contained in this manual may be different with actual BIOS that come with your motherboard.*

## How To Use Phoenix-Award™ BIOS Setup Program

Generally, you can use arrow keys to highlight items that you want to choose, then press <Enter> key to select, and use the <Page Up> and <Page Down> key to change setting values. You can press <Esc> key to quit Phoenix-Award™ BIOS setup program. The following table provides details about how to use keyboard in the Phoenix-Award™ BIOS setup program. Alternatively, it's strongly recommended to install AOpen's newest [WinBIOS Utility](#) to get more detailed description, further powerful functions and advanced setting of BIOS.

Key	Description
Page Up or +	Changing setting to next value or increase the value.
Page Down or -	Changing setting to previous value or decrease value.
Enter	Select the item.
Esc	1. In main menu: Quit and don't save any change. 2. In sub menu: Exit current menu to main menu.
Up Arrow	Highlight previous item.
Down Arrow	Highlight next item.
Left Arrow	Move the light bar to left side of menu.
Right Arrow	Move the light bar to right side of menu.
F6	Load fail-save setting value from CMOS.
F7	Load turbo setting value from CMOS.
F10	Save changed setting and exit setup program.

## How To Enter BIOS Setup

After you finish the setting of jumpers and connect correct cables. Power on and enter the BIOS Setup, press <Del> during [POST \(Power-On Self Test\)](#). Choose "Load Setup Defaults" for recommended optimal performance.

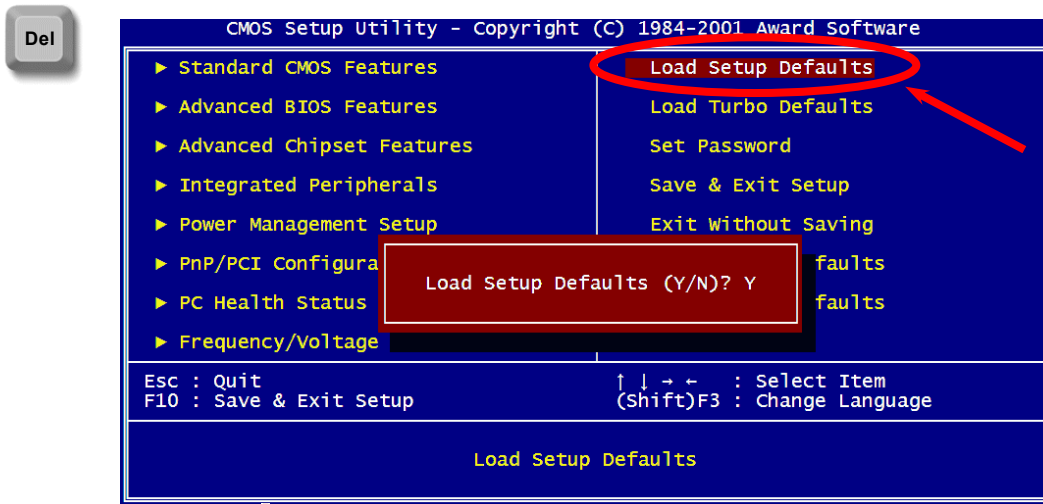

**Warning:** Please avoid of using "Load Turbo Defaults", unless you are sure your system components (CPU, DRAM, HDD, etc.) are good enough for turbo setting.





## BIOS Upgrade under Windows environment



With outstanding R&D ability of AOpen, we now bring you a whole new BIOS Flash wizard ---- EzWinFlash. With an eye to users convenience, EzWinFlash combines the BIOS binary code and flash module together, so the only thing you have to do is just clicking on the utility you downloaded from web and let it helps you complete the flash process automatically. EzWinFlash detects your motherboard and checks the BIOS version cleverly to prevent your system from any possible failure. Moreover, EzWinFlash has been taken into consideration to go with any windows platform you might be using, no matter if you're using Windows 95/98, 98SE/ME, NT4.0/2000, or Windows XP.

In the meanwhile, in order to provide a much more user-friendly operating environment, AOpen EzWinFlash is natively designed to have multi-language function to provide easier way for users' usage in changing BIOS setting.

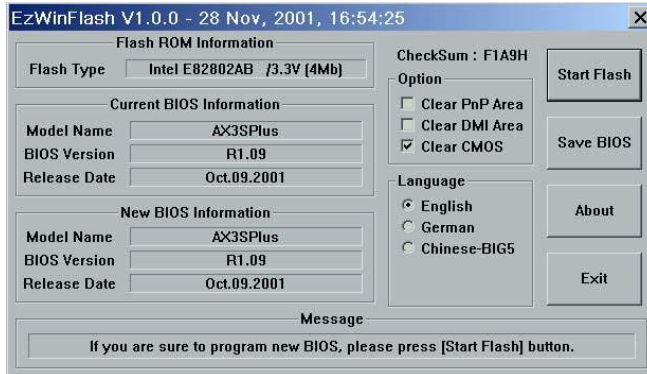

**Caution:** By updating your motherboard, you are taking a risk of BIOS flash failure. If your motherboard is working stable, and there are no major bugs that had been fixed by a latter BIOS revision, we recommend that you DO NOT try to upgrade your BIOS.

If you intent on upgrading, PLEASE BE SURE to get the right BIOS revision for the right motherboard model to avoid any possibility failure.

Note: The model name on this BIOS picture is for reference only. It may not be the exact model name.



You may accomplish BIOS upgrade procedure with EzWinFlash by the following steps, and it's STRONGLY RECOMMENDED to close all the applications before you start the upgrading.

1. Download the new version of BIOS package zip file from AOpen official web site. (ex: <http://english.aopen.com.tw>)
2. Unzip the download BIOS package (ex: WAX4SGL102.ZIP) with WinZip (<http://www.winzip.com>) in Windows environment.
3. Save the unzipped files into a folder, for example, WAX4SGLM102.EXE & WAX4SGLM102.BIN.
4. Double click on the WAX4SGLM102.EXE; EzWinFlash will detect the model name and BIOS version of your motherboard. If you had got the wrong BIOS, you will not be allowed to proceed with the flash steps.
5. You may select preferred language in the main menu, then click [Start Flash] to start the BIOS upgrade procedure.
6. EzWinFlash will complete all the process automatically, and a dialogue box will pop up to ask you to restart Windows. You may click [YES] to reboot Windows.
7. Press <Del> at POST to enter BIOS setup, choose "Load Setup Defaults", then "Save & Exit Setup". Done!

**It is strongly recommended NOT to turn off the power or run any application during FLASH PROCESS.**



**Warning:** *The new BIOS upgrade will permanently replace your original BIOS's settings when flashing. You may need to reconfigure your BIOS setting so that your system can go back to work as normal.*

## WinBIOS Utility







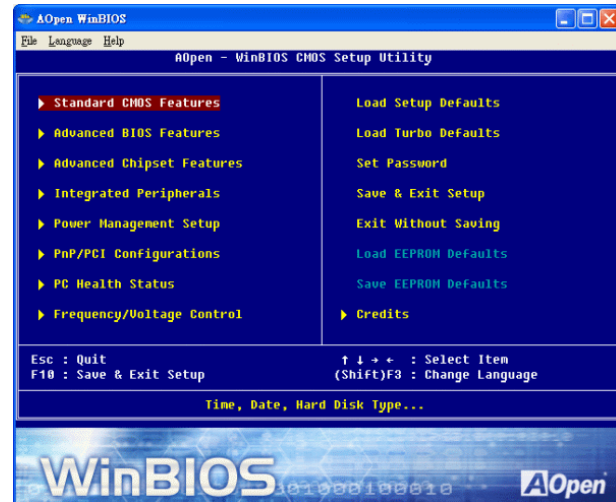

In the past, users have to keep punching the DEL key at a good timing during POST (Power-On-Self-Test) screen to get into the BIOS, which is inconvenient and clumsy. From now on, AOpen provides an easier way to configure your BIOS. WinBIOS is a customized utility for running exclusively on AOpen motherboards, which allows you to setup your BIOS under Windows environment. Designed with traditional-BIOS-alike interface, you may adjust BIOS parameter with clear descriptions for each item.

WinBIOS is natively designed with multi-language support. There are various widely-use languages provided on our website for your downloading, which also helps to prevent wrong settings caused by misunderstanding of the languages. The only thing you have to do is to visit our official website and download your respective language pack (of few KB size), then double-click on it to activate the support with your chosen language.

Moreover, with high scalability, either for newly bought motherboard or the latest BIOS version with new function, you don't have to re-install the whole program again and again. All you have to do is to grab the latest profile from our website, simply double-click on it as well to support the latest version of your BIOS. You don't have to spend any extra effort to have your motherboard supported by WinBIOS.



## Function keys:

It's definitely easy to handle WinBIOS as if you're using traditional BIOS setting. Users can use the arrow keys such as     to move around the items in WinBIOS screen. And use  , "+" or "-" to change the setting value if they are available. Press  to get back to the previous screen. Furthermore, the hotkeys shown in the table may help you and save your time. Some settings may not come into effect until you reboot your system.

**Caution:** After updating your BIOS, please remember to update WinBIOS profile as well. If the upgraded BIOS version is newer than WinBIOS profile, WinBIOS will not be able to launch and a dialog box with error message will pop up. This verification is designed on purpose to protect your BIOS from damaged by wrong profile version.

For the latest WinBIOS profile and language pack modules, you may find them from AOpen official web site as shown below:

<http://english.aopen.com.tw/tech/download/WinBIOS/default.htm>

**Note:** Due to BIOS versions are updated in an extremely fast speed, it's strongly recommended to download the latest BIOS version and WinBIOS profile from our website upon receipt of the motherboard.

Hotkey	Function Description
F1	Get help description.
F2	Item Help
F3	Changing menu language.
F5	Load previous setting
F6	Load setup default setting
F7	Load turbo setting
F10	Save changed setting and exit setup program.
F12	Full Screen / Normal Mode

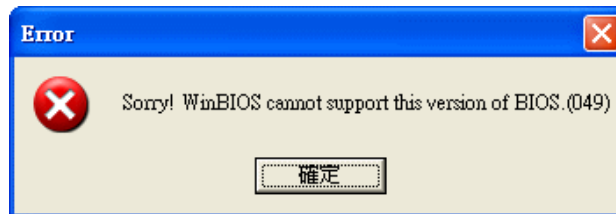

# Glossary

## AC97 CODEC

Basically, AC97 CODEC is the standard structure of PCI sound card. As we know, computer is digital-based, but music is based on analog-based. Therefore, there must be a process to turn digital into analog during the last stage processing of sound in computer. Hence, the component on sound card that play this important task is what we called CODEC.

Audio CODEC 97 (briefly called AC97) is the specification regulated by Intel, and it's about the structure of audio conversion. The special place about CODEC is that it is separated from sound card (CODEC is an independent chipset). Therefore, PCI sound card could possess with 90db and do other application process as well. We called CODEC that meets this structure AC97 CODEC.

## ACPI (Advanced Configuration & Power Interface)

ACPI is the power management specification of PC97 (1997). It intends to save more power by taking full control of power management to operating system and bypass [BIOS](#). The chipset or super I/O chip needs to provide standard register interface to operating system (such as Windows 98). This is a bit similar as the [PnP](#) register interface. ACPI defines ATX momentary soft power switch to control the power state transition.

## ACR (Advanced Communication Riser)

Building on the PC motherboard riser architecture, ACR slot is backward compatible with AMR but beyond the limitation of it. The ACR specification is designed to support modem, audio, Local Area Network (LAN) and Digital Subscriber Line (DSL).

### AGP (Accelerated Graphic Port)

The main function of AGP simply put is to tell monitor what screen information had to be shown, a visual transmission device actually. With the rapid developing of AGP card, we can see that it had been developed from single colorful AGP card to 2D and 3D graphic. AGP supports only memory read/write operation and single-master single-slave one-to-one only. Though AGP and PCI share the same algorithm of 32-bit, its frequencies are 66MHz and 33MHz respectively. AGP interface had been developed from 2X to 8x.

1X AGP, data transfer rate is  $66\text{MHz} \times 4\text{byte} \times 1 = 264\text{MB/s}$

2X AGP, data transfer rate is  $66\text{MHz} \times 4\text{byte} \times 2 = 528\text{MB/s}$

4X AGP, data transfer rate is  $66\text{MHz} \times 4\text{byte} \times 4 = 1056\text{MB/s}$ .

8X AGP, data transfer rate is  $66\text{MHz} \times 4\text{byte} \times 8 = 2112\text{MB/s}$ .

### AMR (Audio/Modem Riser)

The CODEC circuit of AC97 sound/modem solution can be put on motherboard or put on a riser card (AMR card) that connects to motherboard through AMR connector.

### ATA (AT Attachment)

Before talking about ATA (AT Attachment), we must understand **DMA** (Direct Memory Access), which allows devices to skip the CPU devices and access memory directly. DMA specification could not only eliminate the workload of CPU, but also accelerate the transmission of data. DMA begins with a data transfer rate of 16.6MB/Sec, but afterward developed to new data rate of 33.3MB/Sec, which is twice the data rate and we called it **Ultra DMA**. **ATA** details power and data signals between the drive and integrated drive controller and the computer's motherboard. Two drives (master and slave) are supported. The ATA specification allows the drive to connect directly to the ISA bus on the computer. ATA transfer rate then had been developed to 133MHz/Sec and would come out with fastest rate later (please refer to [Serial ATA](#)).

**DMA**, data transfer rate is 16.6MHz/s.

**Ultra DMA**, data transfer rate is  $16.6\text{MHz} \times 2 = 33\text{MB/s}$ .

**ATA/66**, data transfer rate is  $16.6\text{MHz} \times 4 = 66\text{MB/s}$ .

**ATA/100**, data transfer rate is  $16.6\text{MHz} \times 6 = 100\text{MB/s}$ .

**ATA/133**, data transfer rate is  $16.6\text{MHz} \times 8 = 133\text{MB/s}$ .

(ATA/133 uses both rising edge and falling edge as ATA/66 but clock cycle time is reduced to 30ns.)

### **BIOS (Basic Input/Output System)**

BIOS, is a set of assembly routine/program that reside in [EPROM](#) or [Flash ROM](#). BIOS controls Input/output devices and other hardware devices of motherboard. In general, to provide hardware independent portability, operation system and drivers is required to access BIOS without directly access hardware devices.

### **Bluetooth**

Bluetooth is a wireless transferring technology that enables short-range wireless connections between desktop and laptop computers, personal digital assistants (PDAs), cellular phones, printers, scanners, digital cameras and even home appliances. The principle of Bluetooth (a chipset) is to transfer information and voices at the frequency of ISM Band. Every Bluetooth technology devices do come with a standard address for you to connect one-to-one or one-to-seven (to form a Pico-net), with transferring range up to 10 meters (100 meters to follow), using low power radio. Bluetooth do not only possess high transfer rate of 1MB/s, it also could be encrypted with pin code. With hopping rate of 1600 hops per second, it's difficult to be intercepted and are less interrupted by electromagnetic wave.

### **CNR (Communication and Networking Riser)**

The CNR specification provides the PC industry the opportunity to deliver a flexible and cost reduced method of implementing LAN, home networking, DSL, USB, wireless, audio and modem subsystems widely used in today's "connected PCs". The CNR specification is an open industry specification and is supported by OEMs, IHV card manufacturers, silicon supplier and Microsoft.

### **DDR (Double Data Rate) RAM**

DDR RAM utilizes the existing [SDRAM](#) (For ex, PC-100, PC-133) infrastructure and technology while doubling the nominal bandwidth available to systems in an easy to design and simple to adopt way. Based on FSB frequency, DDR RAM on the market are DDR200, DDR266 and DDR333 with more coming around soon.

**DDR200**, transfer bandwidth up to  $200 \times 64 / 8 = 1600 \text{MB/s}$  (PC1600)

**DDR266**, transfer bandwidth up to  $266 \times 64 / 8 = 2100 \text{MB/s}$  (PC2100)

**DDR333**, transfer bandwidth up to  $333 \times 64 / 8 = 2700 \text{MB/s}$  (PC2700)

**DDR400**, transfer bandwidth up to  $400 \times 64 / 8 = 3200 \text{MB/s}$  (PC3200)

### **ECC (Error Checking and Correction)**

The ECC mode needs 8 ECC bits for 64-bit data. Each time memory is accessed; ECC bits are updated and checked by a special algorithm. The ECC algorithm has the ability to detect double-bit error and automatically correct single-bit error while parity mode can only detect single-bit error.

### **EEPROM (Electronic Erasable Programmable ROM)**

Also known as E<sup>2</sup>PROM. Both EEPROM and [Flash ROM](#) can be re-programmed by electronic signals, but the interface technology is different. Size of EEPROM is much smaller than flash ROM.

### **EPROM (Erasable Programmable ROM)**

Traditional motherboard stores BIOS code in EPROM. EPROM can only be erased by ultra-violet (UV) light. If BIOS has to be upgraded, you need to remove EPROM from motherboard, clear by UV light, re-program, and then insert back.



### **EV6 Bus**

EV6 Bus is the technology of Alpha processor from Digital Equipment Corporation. EV6 bus uses both rising and falling clock edge to transfer data, similar as DDR RAM or ATA/66 IDE bus.

EV6 Bus Speed = CPU external bus clock x 2.

**200 MHz EV6 bus**, 200MHz = 100 MHz external bus clock x 2

### **FCC DoC (Declaration of Conformity)**

The DoC is component certification standard of FCC EMI regulations. This standard allows DIY component (such as motherboard) to apply DoC label separately without a shielding of housing.

### **FC-PGA (Flip Chip-Pin Grid Array)**

FC means Flip Chip, FC-PGA is a package of Intel for Pentium III for 0.18 $\mu$ m process CPU, which can be plugged into SKT370 socket.

### **FC-PGA2 (Flip Chip-Pin Grid Array)**

After FC-PGA, FC-PGA2 is the package for 0.13 $\mu$ m process CPU developed by Intel, which can be plugged into SKT423/478 socket as well.

### **Flash ROM**

Flash ROM can be re-programmed by electronic signals. It is easier for BIOS to upgrade by a flash utility, but it is also easier to be infected by virus. Because of increase of new functions, BIOS size is increased from 64KB to 512KB (4M bit).

## Hyper Threading

Hyper-Threading technology is an innovative design from Intel that enables multi-threaded software applications to process threads in parallel within each processor resulting in increased utilization of processor execution resources. As a result, an average improvement of ~40% in CPU resource utilization yields higher processing throughput.

## IEEE 1394

IEEE 1394, which also called Firewire, is a serial data transfer protocol and interconnection system. The main feature of the Firewire that assures its adoption for the digital video and audio (A/V) consumer application is its low cost. Fire wire interface is capable of supporting various high-end digital A/V applications, such as consumer A/V device control and signal routing, Digital Video (DV) editing, home networking, and more than 32 channels of digital mixing. Gone are those days of expensive video capture cards. Firewire allows for video capture from both newer DV camcorders with Firewire ports and older analog equipment using A/V to Firewire converters.

The advantages of the IEEE1394:

**High data transfer rate** – Start from 400 Mbps, (with 800/1600/3200 Mbps coming soon), which is about 30 times faster than USB 1.1.

**Supports up to 63 devices** (16 - daisy chained) with cable length up to about 4.5 m (14 feet).

**Hot-pluggable** (like USB). No need to turn of your device to connect or disconnect, and you don't need to reboot your PC. Also, it is a plug-and-play bus.

**IEEE1394 is very easy to connect** (Like USB1.1/2/0).

## Parity Bit

The parity mode uses 1 parity bit for each byte, normally it is even parity mode, that is, each time the memory data is updated, parity bit will be adjusted to have even count "1" for each byte. When next time, if memory is read with odd number of "1", the parity error is occurred and this is called single bit error detection.

### **PCI (Peripheral Component Interface) Bus**

Developed by Intel, Peripheral Component Interconnect (PCI) is a local bus standard. A bus is a channel used to transfer data to (input) and from (output) a computer and to or from a peripheral device. Most PCs have a PCI bus usually implemented at 32-bits providing a 33 MHz clock speed with a throughput rate of 133 MBps.

### **PDF Format**

With PDF file, it is easy to do universal document exchange. Virtually any document may be converted in Portable Document Format (PDF). Contents in PDF documents are exactly the same as the original file, including fonts and graphics, and they can be distributed by e-mail or stored on the World Wide Web, an intranet, a file system, or a CD-ROM for other users to view on any platforms. You may download Acrobat Reader in order to read PDF file from its website ([www.adobe.com](http://www.adobe.com)).

### **PnP (Plug and Play)**

Oversimplified, Plug-and-Play automatically tells the software (device drivers) where to find various pieces of hardware (devices) such as modems, network cards, sound cards, etc. Plug-and-Play's task is to match up physical devices with the software (device drivers) that operates them and to establish channels of communication between each physical device and its driver.

### **POST (Power-On Self Test)**

The BIOS self-test procedure after power-on, sometimes, it is the first or the second screen shown on your monitor during system boot.

### **PSB (Processor System Bus) Clock**

PSB Clock means the external bus clock of CPU.

CPU internal clock = CPU PSB Clock x CPU Clock Ratio

### **RDRAM (Rambus Dynamic Random Access Memory)**

A DRAM technology developed by Rambus Corporation\*, to achieve high speed of memory through the use of multiple channels in parallel by 16-bits. Basically, RDRAM uses new structure of Multibank, which is quite different from FPM, EDO, SDRAM. Using different memory module as well, RDRAM uses "RIMM" with transfer rate of 600/700/800MHz, providing bandwidth as high to 1.6GB.

### **RIMM (Rambus Inline Memory Module)**

184-pin memory module that supports [RDRAM](#) memory technology. A RIMM memory module may contain up to maximum of 16 RDRAM devices.

### **SDRAM (Synchronous DRAM)**

SDRAM is one of the DRAM technologies that allow DRAM to use the same clock as the CPU host bus (EDO and FPM are asynchronous and do not have clock signal). It is similar as PBSRAM to use burst mode transfer. SDRAM comes in 64-bit 168-pin DIMM and operates at 3.3V, and have been gradually replaced by DDR RAM.

### **SATA (Serial ATA)**

The Serial ATA specification is designed to overcome speed limitations while enabling the storage interface to scale with the growing media rate demands of PC platforms. Serial ATA is to replace parallel [ATA](#) with the compatibility with existing operating systems and drivers, adding performance headroom for years to come. It is developed with data transfer rate of 150 Mbytes/second, and 300M/bs, 600M/bs to come. It reduces voltage and pins count requirements and can be implemented with thin and easy to route cables.

### **SMBus (System Management Bus)**

SMBus is also called I<sup>2</sup>C bus. It is a two-wire bus developed for component communication (especially for semiconductor IC). For example, set clock of clock generator for jumper-less motherboard. The data transfer rate of SMBus is only 100Kbit/s, it allows one host to communicate with CPU and many masters and slaves to send/receive message.

### **SPD (Serial Presence Detect)**

SPD is a small ROM or [EEPROM](#) device resided on the DIMM or [RIMM](#). SPD stores memory module information such as DRAM timing and chip parameters. SPD can be used by [BIOS](#) to decide best timing for this DIMM or RIMM.

### **USB 2.0 (Universal Serial Bus)**

A Universal Serial Bus (USB) is an external bus (an interconnect) standard that supports data transfer rates of 12 Mbps. A single USB port can be used to connect up to 127 peripheral devices, such as mouse, modems and keyboards. Introduced in 1996, USB has completely replaced serial and parallel ports. It also supports plug-and-play installations and hot plugging. Plug-and-play is the ability to add and remove devices to a computer while the computer is running and have the operating system automatically recognize the change. USB 2.0, which supports data transfer rates of 480 Mbps, has been widely used in motherboard these days.

### **VCM (Virtual Channel Memory)**

NEC's Virtual Channel Memory (VCM) is a new DRAM core architecture that dramatically improves the memory system's ability to service multimedia requirements. VCM increases memory bus efficiency and performance of any DRAM technology by providing a set of fast static registers between the memory core and I/O pins. Using VCM technology results in reduced data access latency and reduced power consumption.

### **Wireless LAN – 802.11b**

802.11 is a specification developed by IEEE and Wireless LAN technology, which is an interface between a wireless client and a base station or between two wireless clients.

802.11 family includes the following specifications and with more coming:

**802.11** = 1 or 2 Mbps transmission in the 2.4 GHz band, using either frequency hopping spread spectrum (FHSS) or direct sequence spread spectrum (DSSS).

**802.11a** = 54 Mbps in the 5GHz band, using orthogonal frequency division multiplexing)

**802.11b** (11 Mbps transmission in the 2.4 GHz band, using direct sequence spread spectrum (DSSS).

### **ZIP file**

A compressed file format to reduce file size. To unzip file, run shareware PKUNZIP (<http://www.pkware.com/>) for DOS and other operating system or WINZIP (<http://www.winzip.com/>) for windows environment.



# Troubleshooting

If you encounter any trouble to boot your system, follow the procedures accordingly to resolve the problem.

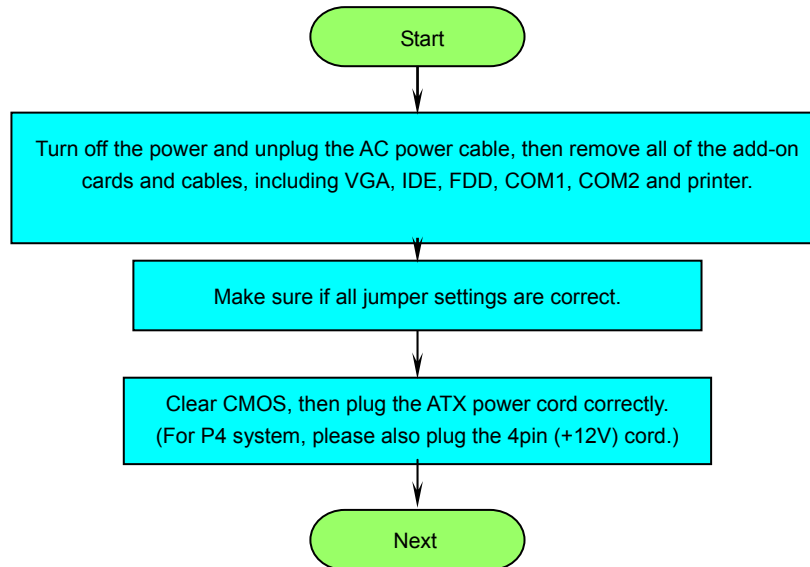

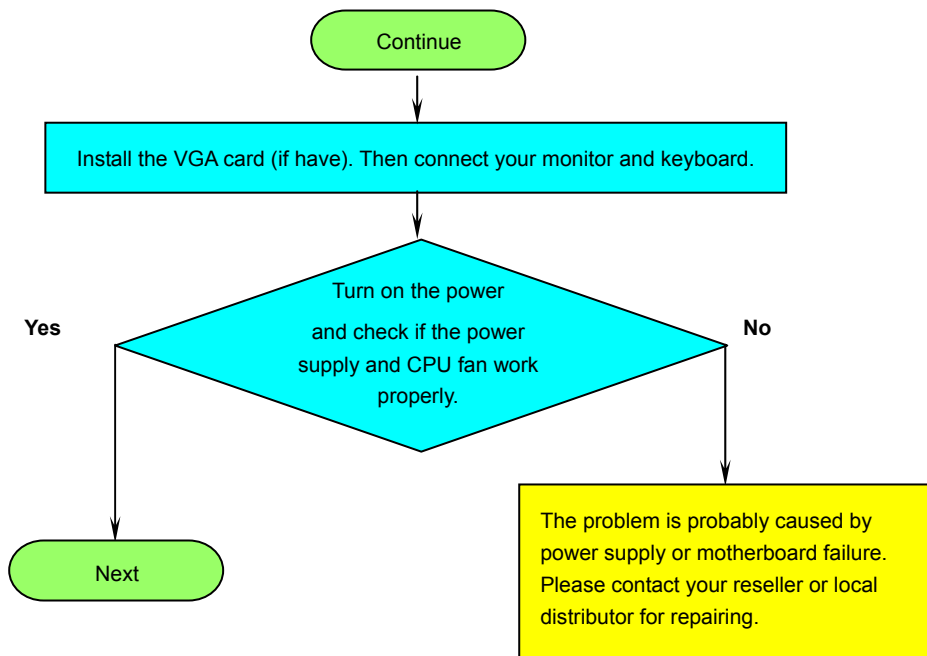



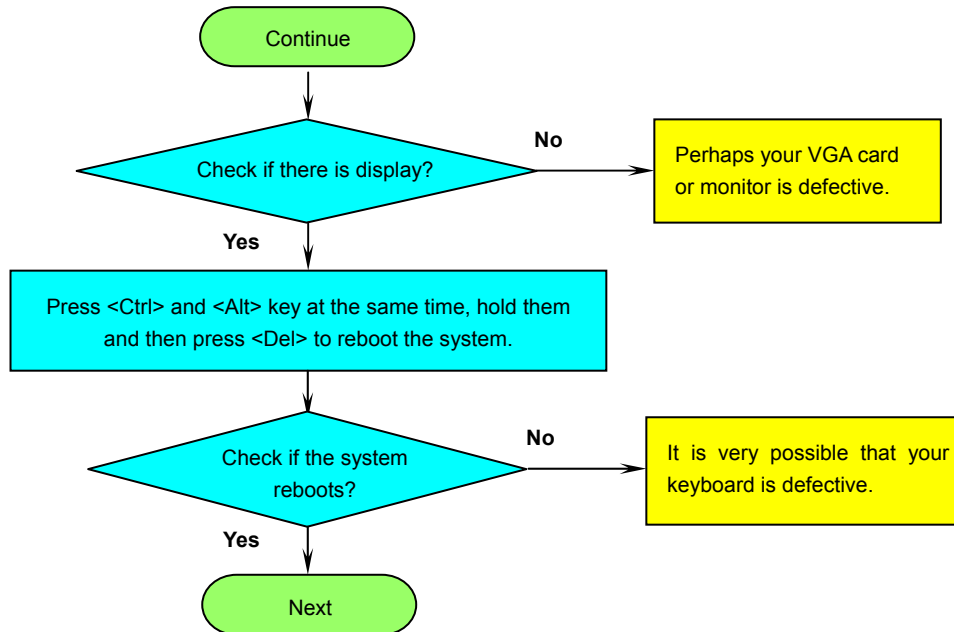

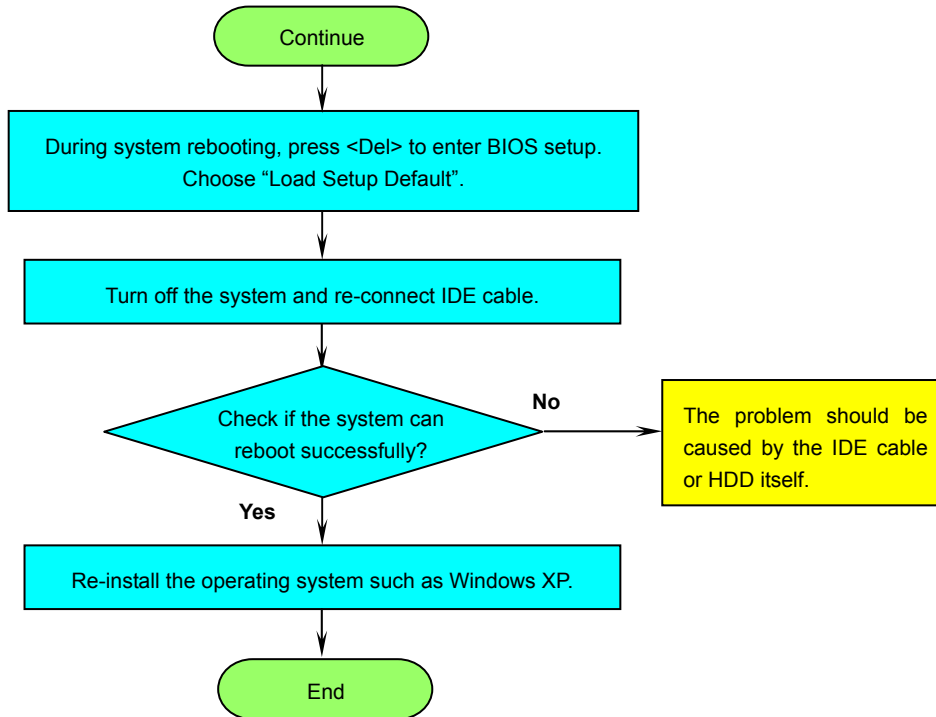



# Technical Support

Dear Customer,

Thanks for choosing AOpen products. To provide the best and fastest service to our customer is our first priority. However, we receive numerous emails and phone-calls worldwide everyday, it is very hard for us to serve everyone on time. We recommend you follow the procedures below and seek help before contact us. With your help, we can then continue to provide the best quality service to more customers.

Thanks very much for your understanding!

AOpen Technical Supporting Team

**1**

**Online Manual:** To download manual, please log on and then select your preferred language. Under “Type” directory, choose “Manuals” to go to our manual database. You can also find the manual and EIG in AOpen Bonus Pack.

<http://download.aopen.com.tw/downloads>

**2**

**Test Report:** We recommend you to choose board/card/device from the compatibility test reports for assembling your PC. It may prevent incompatibility problems.

<http://english.aopen.com.tw/tech/report/default.htm>

**3**

**FAQ:** Here we list problems that users often encounter and FAQ (Frequently Asked Questions). You may be able to find a solution to your problem.

<http://club.aopen.com.tw/faq/>

**4**

**Download Software:** After log on and having language selected, you may get the latest updated BIOS/utility and drivers you need under “Type” directory. In most case, newer versions of drivers and BIOS have solved earlier bugs or compatibility problems.

<http://download.aopen.com.tw/downloads>

**5**

**eForum:** AOpen eForum is provided to discuss our products with other users, in which your problem probably had been discussed before or will be answered. After log on, you may select your preferred language under "Multi-language".

<http://club.aopen.com.tw/forum/>

**6**

**Contact Distributors/Resellers:** We sell our products through resellers and integrators. They should know your system configuration very well and should be able to solve your problem efficiently and provide important reference for you.

**7**

**Contact Us:** Please prepare detail system configuration and error symptom before contacting us. The **part number**, **serial number** and **BIOS version** are also very helpful.

### Part Number and Serial Number

The Part Number and Serial number are printed on bar code label. You can find this bar code label on the outside packing or on the component side of PCB. For example:



**P/N: 91.88110.201** is part number, **S/N: 91949378KN73** is serial number.

**Model name and BIOS version**

Model name and BIOS version can be found on upper left corner of first boot screen (POST screen). For example:



**AX4SG-L R1.00** Mar.01.2003 AOpen Inc.

Award Plug and Play BIOS Extension v1.0A

Copyright © 2003, Award Software, Inc.

**AX4SG-L** is model name of motherboard; **R1.00** is BIOS version.



# Product Registration



Thank you for choosing AOpen product. AOpen encourages you to spend few minutes in completing the following product registration. To register your product will ensure the high quality of services from AOpen. After the registration, you will:

- Have opportunities to play online slot machine and win a prize from AOpen by accumulating your bonuses for later prize exchange.
- Be upgraded to gold membership of Club AOpen program.
- Receive email notification about product safety alerts. Its purpose is to alert consumers quickly and conveniently when products contain technical issues.
- Receive email notification about latest product's announcements.
- Be able to personalize your AOpen web pages.
- Receive e-mail notification about latest BIOS/Driver/Software release information.
- Have opportunities to participate special product promotional programs.
- Enjoy higher service priority to receive technical assistance provided by AOpen specialists worldwide.
- Be able to join the discussions of web-based news groups.

AOpen makes sure that the information you provide is encrypted, so that it cannot be read or intercepted by other people or companies. Further, AOpen will not disclose any of information you submitted under any conditions. Please consult our [online privacy policy](#) for further information on our company policy.

**Note:** *If registering products purchased from different dealers/retails and/or purchased on different dates, please submit a separate form for each product.*





## How to Contact Us



Please do not hesitate contact us if you have any problem about our products. Any opinion will be appreciated.

Pacific Rim  
AOpen Inc.  
Tel: 886-2-3789-5888  
Fax: 886-2-3789-5899

Europe  
AOpen Computer b.v.  
Tel: 31-73-645-9516  
Email: Support@AOpen.NL

America  
AOpen America Inc.  
Tel: 1-510-498-8928  
Fax: 1-408-922-2935

China  
艾爾鵬國際貿易(上海)有限公司  
Tel: 86-21-6225-8622  
Fax: 86-21-6225-7926

Germany  
AOpen Computer GmbH.  
Tel: 49-2102-157700  
Fax: 49-2102-157799

Japan  
AOpen Japan Inc.  
Tel: 81-048-290-1800  
Fax: 81-048-290-1820

Web Site: <http://www.aopen.com.tw>

E-mail: Send us email by going through the contact form below.

English <http://english.aopen.com.tw/tech/default.htm>

Japanese <http://www.aopen.co.jp/tech/default.htm>

Chinese <http://www.aopen.com.tw/tech/default.htm>

German <http://www.aopencom.de/tech/default.htm>

Simplified Chinese <http://www.aopen.com.cn/tech/default.htm>

