

AX4GE Tube

AX4PE Tube

Online Manual

DOC. NO.: AX4GET-OL-E0210A

Overview

Hardware
Installation

Drivers &
Utilities

AWARD
BIOS Setup





Glossary









Troubleshooting &
Technical Support



What's in this manual

AX4GE Tube / AX4PE Tube	1
<i>What's in this manual</i>	2
<i>You Must Notice</i>	9
<i>Before You Start</i>	10
<i>Overview</i>	11
<i>Feature Highlight</i>	12
<i>Quick Installation Procedure</i>	16
<i>Motherboard Map</i>	17
<i>Block Diagram</i>	18
Hardware Installation	19
<i>About "User Upgrade Optional" and "Manufacture Upgrade Optional"</i>	20
<i>JP14 Clear CMOS Data</i>	21
<i>CPU Installation</i>	22
<i>CPU Jumper-less Design</i>	25
<i>AOpen "Watch Dog Timer"</i>	26
<i>Full-range Adjustable CPU Core Voltage</i>	27
<i>CPU and System Fan Connector (with H/W Monitoring)</i>	29
<i>DIMM Sockets and Memory Adjustable Voltage</i>	30



 DDR 266(PC2100) and DDR 333(PC2700)	32
Front Panel Connector.....	33
ATX Power Connector.....	34
AC Power Auto Recovery.....	34
STBY LED (Standby LED) and BOOT LED.....	35
IDE and Floppy Connector.....	36
 ATA/133 Supported.....	38
 Serial ATA Supported.....	39
Connecting Serial ATA Disk.....	40
IrDA Connector.....	41
AGP (Accelerated Graphic Port) Expansion Slot and Adjustable Voltage	42
AGP Protection Technology and AGP LED.....	43
WOL (Wake on LAN)	44
Game Port Bracket Supported.....	46
Support 10/100 Mbps LAN onboard.....	47
JP28 Keyboard/Mouse Wake-up Jumper.....	48
Die-Hard BIOS and JP24 Die-Hard BIOS Select Jumper.....	49
PC99 Color Coded Back Panel.....	50
 Support 2 nd USB 2.0 Ports	51

Case Open Connector	52
CD Audio Connector	53
AUX-IN Connector	54
COM2 Connector	55
Front Audio Connector	56
 Tube Related components	57
 TP3 Tube Power Jumper	58
 S/PDIF (Sony/Philips Digital Interface) Connector	59
 Super 5.1 Channel Audio Effect	60
 FM Radio Card Supported	61
 The noise is gone!! ---- SilentTek	63
Over-current Protection	67
Hardware Monitoring	68
Resettable Fuse	69
Low ESR Capacitor	70
Layout (Frequency Isolation Wall)	72
Enlarged Aluminum Heatsink	73
 Vivid BIOS technology	74
 Open JukeBox Player	75

 Hyper Threading Technology	79
Driver and Utility	81
Auto-run Menu from Bonus CD	82
Installing Intel® Chipset Software Installation Utility	83
Installing Intel IAA Driver	84
Installing Intel Extreme Graphic Driver (For AX4GE Tube)	85
Installing Promise SATA Driver	86
Installing LAN Driver	96
Installing Onboard Audio Driver	97
Installing USB2.0 Driver	98
AOCConfig Utility	101
Installing Hardware Monitoring Utility	103
Phoenix-AWARD BIOS	104
About BIOS Function Description	105
How To Use Phoenix-Award™ BIOS Setup Program	106
How To Enter BIOS Setup	108
 BIOS Upgrade under Windows environment	109
Overclocking	111
VGA Card & Hard Disk	112



Glossary 113

AC97 113

ACPI (Advanced Configuration & Power Interface) 113

AGP (Accelerated Graphic Port) 113

AMR (Audio/Modem Riser) 114

AOpen Bonus Pack CD 114

APM (Advanced Power Management) 114

ATA (AT Attachment) 114

ATA/66 114

ATA/100 115

ATA/133 115

BIOS (Basic Input/Output System) 115

Bus Master IDE (DMA mode) 115

CNR (Communication and Networking Riser) 116

CODEC (Coding and Decoding) 116

DDR (Double Data Rated) SDRAM 116

DIMM (Dual In Line Memory Module) 116

DMA (Direct Memory Access) 117

ECC (Error Checking and Correction) 117



<i>EDO (Extended Data Output) Memory</i>	117
<i>EEPROM (Electronic Erasable Programmable ROM)</i>	117
<i>EPROM (Erasable Programmable ROM)</i>	117
<i>EV6 Bus</i>	118
<i>FCC DoC (Declaration of Conformity)</i>	118
<i>FC-PGA (Flip Chip-Pin Grid Array)</i>	118
<i>Flash ROM</i>	118
<i>FSB (Front Side Bus) Clock</i>	119
<i>I²C Bus</i>	119
<i>IEEE 1394</i>	119
<i>Parity Bit</i>	120
<i>PBSRAM (Pipelined Burst SRAM)</i>	120
<i>PC-100 DIMM</i>	120
<i>PC-133 DIMM</i>	120
<i>PC-1600, PC-2100 or PC-2700 DDR DRAM</i>	121
<i>PCI (Peripheral Component Interface) Bus</i>	121
<i>PDF Format</i>	121
<i>PnP (Plug and Play)</i>	121
<i>POST (Power-On Self Test)</i>	122

RDRAM (Rambus DRAM)..... 122

RIMM (Rambus Inline Memory Module)..... 122

SDRAM (Synchronous DRAM) 122

Shadow E²PROM 122

SIMM (Single In Line Memory Module) 123

SMBus (System Management Bus) 123

SPD (Serial Presence Detect)..... 123

Ultra DMA 124

USB (Universal Serial Bus)..... 124

USB2.0 (Universal Serial Bus) 124

VCM (Virtual Channel Memory) 125

ZIP file 125

Troubleshooting 126

Technical Support..... 130

Product Registration..... 133

How to Contact Us..... 134

You Must Notice



Adobe, the Adobe logo, Acrobat is trademarks of Adobe Systems Incorporated.

AMD, the AMD logo, Athlon and Duron are trademarks of Advanced Micro Devices, Inc.

Intel, the Intel logo, Intel Celeron, Pentium II, Pentium III and Pentium 4 are trademarks of Intel Corporation.

Microsoft, Windows, and Windows logo are either registered trademarks or trademarks of Microsoft Corporation in the United States and/or other countries.

All product and brand names used on this manual are used for identification purposes only and may be the registered trademarks of their respective owners.

All of the specifications and information contained in this manual are subject to change without notice. AOpen reserves the right to revise this publication and to make reasonable changes. AOpen assumes no responsibility for any errors or inaccuracies that may appear in this manual, including the products and software described in it.

This documentation is protected by copyright law. All rights are reserved.

No part of this document may be used or reproduced in any form or by any means, or stored in a database or retrieval system without prior written permission from AOpen Corporation.

Copyright© 1996-2002, AOpen Inc. All Rights Reserved.

Before You Start



This Online Manual will introduce to the user how this product is installed. All useful information will be described in later chapters. Please keep this manual carefully for future upgrades or system configuration changes. This Online Manual is saved in [PDF format](#), we recommend using Adobe Acrobat Reader 4.0 for online viewing, it is included in [Bonus CD](#) or you can get free download from [Adobe web site](#).

Although this Online Manual is optimized for screen viewing, it is still capable for hardcopy printing, you can print it by A4 paper size and set 2 pages per A4 sheet on your printer. To do so, choose **File > Page Setup** and follow the instruction of your printer driver.

Thanks for the help of saving our earth.

Overview

Thank you for choosing AOpen AX4GE Tube / AX4PE Tube motherboard. AX4GE Tube / AX4PE Tube is Intel® Socket 478 motherboard (M/B) based on the micro ATX form factor featuring the [Intel 845GE / Intel 845PE chipsets](#). As high performance chipset built in the M/B, AX4GE Tube / AX4PE Tube motherboard supports Intel® Socket 478 Pentium® 4 (Willamette / Northwood) and 400/533 MHz [Front Side Bus \(FSB\)](#) clock. In the AGP performance, it has one AGP slot and supports AGP 4X mode and pipelined spilt-transaction long burst transfer up to 1056MB/sec. According to different customer's requirements, this motherboard supports DDR266 (PC2100) SDRAM and DDR333 (PC2700) SDRAM up to 2GB maximum. The onboard IDE controller supports [Ultra DMA 33/66/100](#), Promise ATA133 and Serial ATA mode and there are 3 PCI slots provided on this board. In addition, AX4GE Tube / AX4PE Tube Motherboard incorporates [Sovtek 6922 dual Triode tube](#) to provide you an incredible sound effects that even audiophiles would be stunned when they listen to the music. Besides, AX4GE Tube / AX4PE Tube has an [AC97 CODEC](#) chipset onboard providing high performance and magic surround stereo sound to let people enjoy working with it. Now, let's enjoy all features from AOpen AX4GE Tube / AX4PE Tube motherboard.

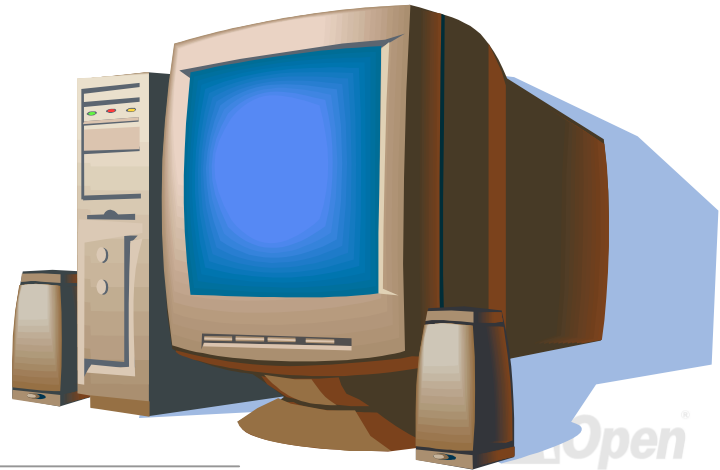

Feature Highlight

CPU

Supports Intel® Socket 478 Pentium® 4 (Willamette / Northwood) 1.4GHz~2.8GHz+ with 400/533MHz [Front Side Bus \(FSB\)](#) designed for Socket 478 technology.

Chipset

The 845GE/PE chipset contains two core components designed for the desktop platform: the 845GE/PE Graphics Memory Controller Hub (GMCH), and the Intel I/O Controller Hub 4 (ICH4). These components are interconnected via an Intel proprietary interface called Hub Interface. The Hub Interface is designed into the 845GE/PE chipset to provide an efficient, high bandwidth communication channel between the GMCH and the ICH4. The GMCH component provides the processor interface, system memory interface, Hub interface, AGP interface, and an integrated graphics device with analog and digital display ports (845GE only). The ICH4 integrates a Universal Serial Bus 2.0 controller, Ultra ATA/100 Controller, Low Pin Count interface, Firmware Hub Flash BIOS interface controller, PCI interface controller, integrated LAN, AC'97 digital controller, and a Hub Interface for communication with the GMCH.

Expansion Slots

Including three 32-bit/33MHz PCI, one AGP 4X slots. The [PCI](#) local bus throughput can be up to 132MB/s. The [Accelerated Graphics Port \(AGP\)](#) specification provides a new level of video display sophistication and speed. The AGP video cards support data transfer rate up to 1056MB/s. AX4GE Tube / AX4PE Tube motherboard includes one AGP expansion slot for a bus mastering AGP graphic card. For AD and SBA signaling, AX4GE Tube / AX4PE Tube motherboard can support 4X mode. Of three PCI slots provided, all of them are master PCI slots with arbitration and decoding for all integrated functions and LPC bus.

Memory

Provides three 184-pin DDR [SDRAM](#) DIMM sockets that support up to 2GB of [PC2700](#)(DDR333) and [PC2100](#)(DDR266) compliant SDRAM (Synchronous Dynamic Random Access Memory) (Please note that only CPU FSB 533MHz supports DDR333).

Watch Dog Timer

Includes AOpen “Watch Dog Timer” function that can auto-reset system in 4.8 seconds when you fail to system overclocking.

1MHz Stepping Frequency Adjustment

Provides “1MHz Stepping Frequency Adjustment” function in the BIOS. This magic function allows you to adjust CPU [FSB](#) frequency from 100~248MHz by 1MHz stepping adjustment, and helps your system get maximum performance.

AGP Protection Technology

With AGP Protection Technology implemented, this motherboard will automatically detect the voltage of AGP card and prevent your chipsets from being burnt out.

LAN Port

On the strength of Intel ICH4 on board, it provides 10/100 Mbps Ethernet for office and home use.

Ultra DMA 33/66/100 Bus Master IDE

Comes with an on-board PCI Bus Master IDE controller with two connectors that allow you to connect four IDE devices in two channels, supporting [Ultra DMA](#) 33/66/100/133, PIO Modes 3 and 4 and Bus Master IDE DMA Mode 5, and other Enhanced IDE devices. The onboard Promise PDC20375 chip supports ATA133 and the latest Serial ATA functions; you can connect two Serial ATA devices and one ATA133 device on this motherboard.

On-board AC'97 Sound

AX4GE Tube / AX4PE Tube uses RealTek [AC97](#) sound chip. This on-board audio includes a complete audio recording and playback system.

Sovtek 6922 Dual Triode Tube

This tube Motherboard incorporates [Sovtek 6922 dual Triode tube](#) to provide you the incredible sound effects that even audiophiles would be stunned when they listened the music.

Six USB2.0 Ports

Provides four ports on the back panel, one [USB](#) connector on the board, providing a total of six USB2.0 interface devices such as mouse, keyboard, modem, scanner, etc.

S/PDIF Connectors

S/PDIF (Sony/Philips Digital Interface) is the newest audio transfer file format, which provides impressive quality through optical fiber and allows you to enjoy digital audio instead of analog audio.

Power Management/Plug and Play

Supports the power management function that conforms to the power-saving standards of the U.S. Environmental Protection Agency (EPA) Energy Star program. It also offers [Plug-and-Play](#), which helps save users from configuration problems, thus making the system much user-friendlier.

Hardware Monitoring Management

Supports CPU or system fans status, temperature and voltage monitoring and alert, through the on-board hardware monitor module.

Enhanced ACPI

Fully implement the [ACPI](#) standard for Windows[®] 98/ME/2000 series compatibility, and supports Soft-Off, STR (Suspend to RAM, S3), STD (Suspend to Disk, S4) features.

Super Multi-I/O

Provides two high-speed UART compatible serial ports and one parallel port with EPP and ECP capabilities. UART can also be directed from COM1 to the Infrared Module for the wireless connections.

Quick Installation Procedure

This page gives you a quick procedure on how to install your system. Follow each step accordingly.

1. [Installing CPU and Fan](#)
2. [Installing System Memory \(DIMM\)](#)
3. [Connecting Front Panel Cable](#)
4. [Connecting IDE and Floppy Cable](#)
5. [Connecting ATX Power Cable](#)
6. [Connecting Back Panel Cable](#)
7. [Power-on and Load BIOS Setup Default](#)
8. [Setting CPU Frequency](#)
9. Reboot
10. Installing Operating System (such as Windows 98)
11. [Installing Driver and Utility](#)

Motherboard Map

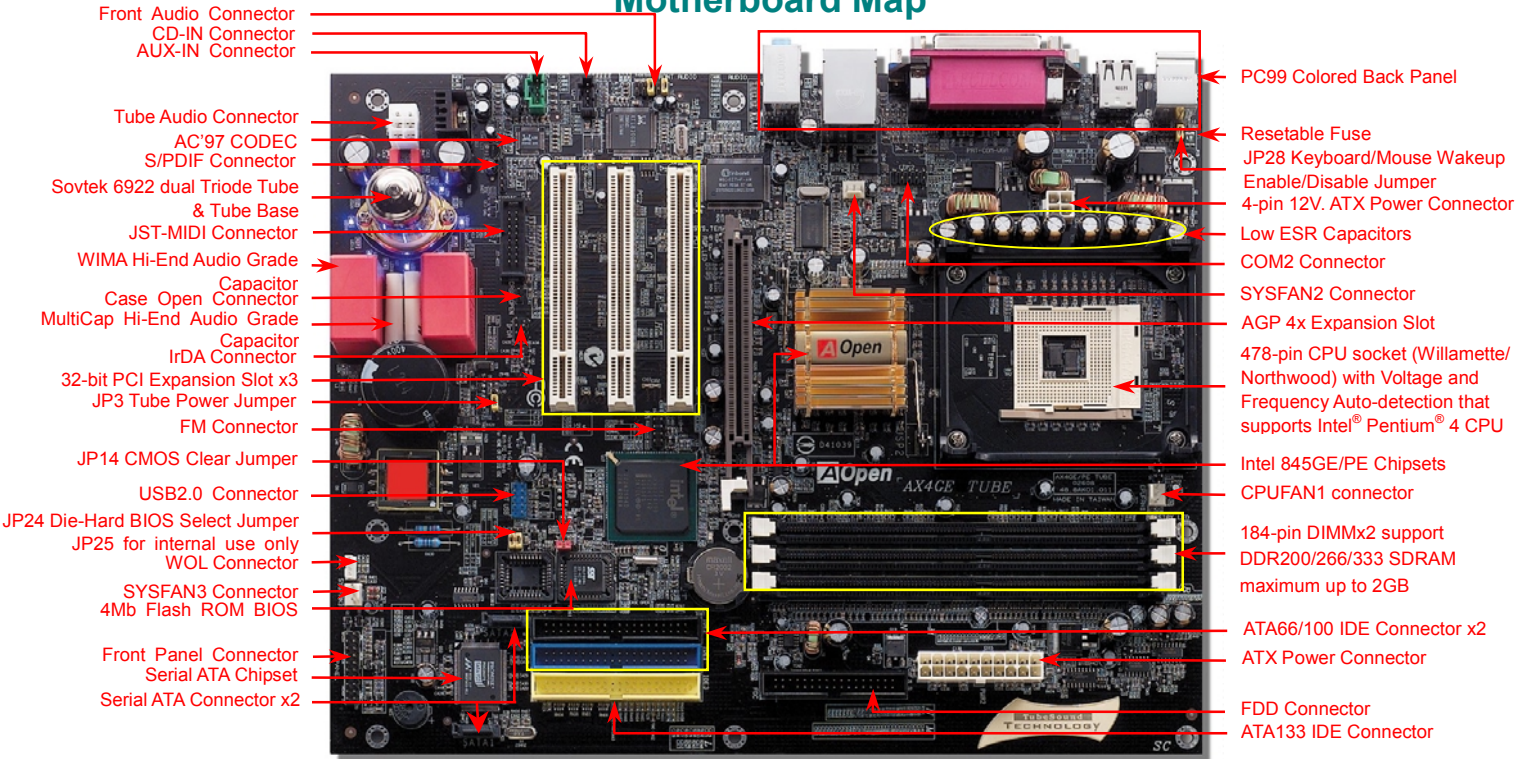

Block Diagram

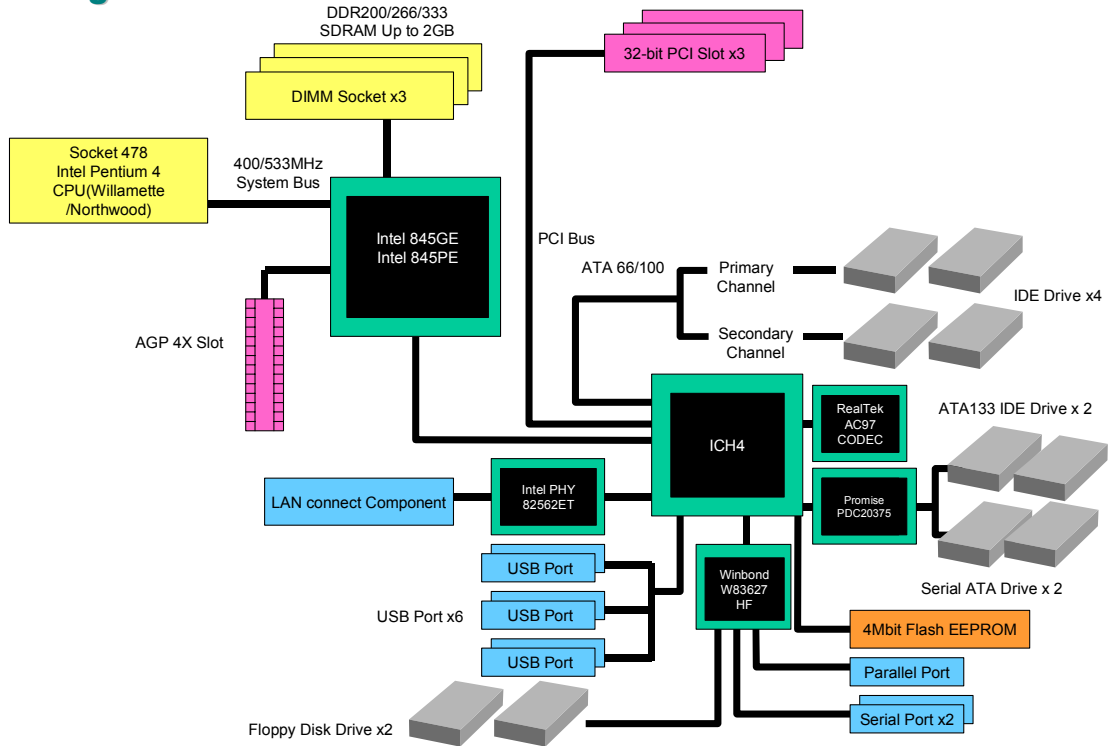

Hardware Installation

This chapter describes jumpers, connectors and hardware devices of this motherboard.



Note: *Electrostatic discharge (ESD) can damage your processor, disk drives, expansion boards, and other components. Always observe the following precautions before you install a system component.*

1. *Do not remove a component from its protective packaging until you are ready to install it.*
2. *Wear a wrist ground strap and attach it to a metal part of the system unit before handling a component. If a wrist strap is not available, maintain contact with the system unit throughout any procedure requiring ESD protection.*

About “User Upgrade Optional” and “Manufacture Upgrade Optional”...

When you read this online manual and start to assemble your computer system, you may notice that some of the functions are marked as “User Upgrade Optional” or “Manufacture Upgrade Optional”. Although all of AOpen’s motherboards have included many amazing and powerful features, sometimes not every user is familiar with these powerful features. As a result of this we define features that can be upgraded by users as “User Upgrade Optional”. You can upgrade these functions by purchasing additional devices. As for functions that cannot be upgraded by users, we define them as “Manufacture Upgrade Optional”. If need be, you can contact our local distributors or resellers to purchase “Manufacture Upgrade Optional” components, and again you are also welcome to visit our official website at english.aopen.com.tw for detail information.



JP14 Clear CMOS Data

You can clear CMOS to restore system default setting. To clear CMOS, follow the procedure below.

1. Turn off the system and unplug the AC power.
2. Remove ATX power cable from connector PWR2.
3. Locate JP14 and short pins 2-3 for a few seconds.
4. Return JP14 to its normal setting by shorting pin 1 & pin 2.
5. Connect ATX power cable back to connector PWR2.

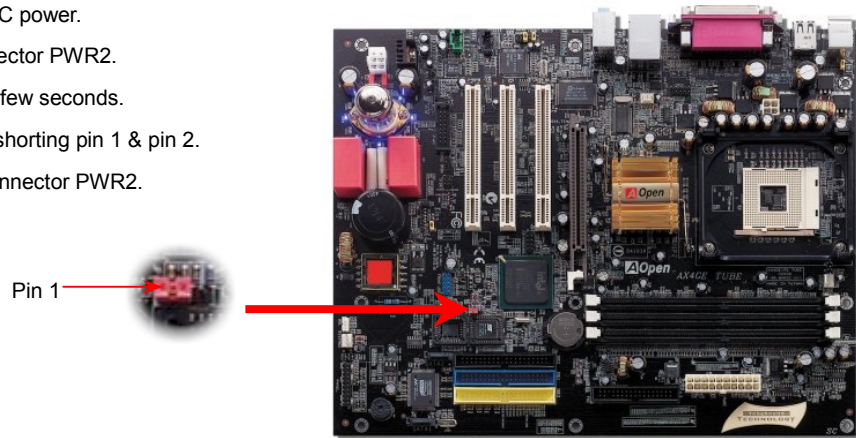

Normal
(default)



Clear CMOS

Tip: When should I Clear CMOS?

1. Boot fail because of overclocking...
2. Forget password...
3. Troubleshooting...

CPU Installation

This motherboard supports Intel® Pentium 4 Socket 478 series CPU (Willamette / Northwood). Be careful of CPU orientation when you plug it into CPU socket.

1. Pull up the CPU socket lever and up to 90-degree angle.
2. Locate Pin 1 in the socket and look for mark on the CPU upper interface. Match Pin 1 and cut edge, then insert the CPU into the socket.

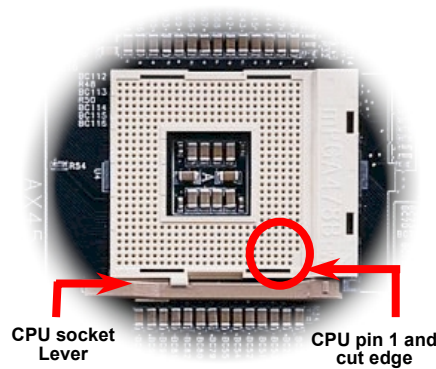
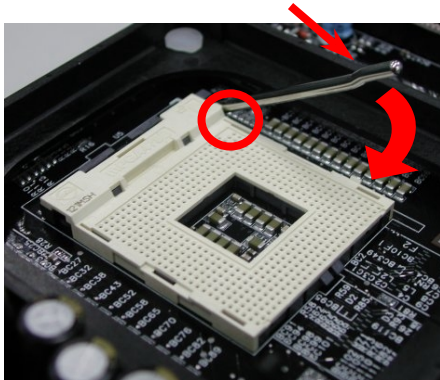

Note: Those pictures are for example only; they may not look the same with the motherboard you purchased.

3. Press down the CPU socket lever and finish CPU installation.

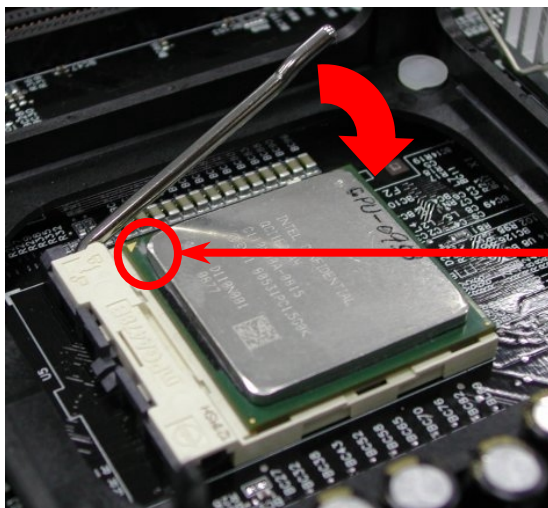

CPU cut edge

Note: If you do not match the CPU socket Pin 1 and CPU cut edge well, you may damage the CPU.

Note: This socket supports Micro-FC-PGA2 package CPU, which is the latest CPU package developed by Intel. Other forms of CPU package are impossible to be fitted in.

Note: This picture is for example only; it may not look the same with the motherboard you purchased.

CPU Fan Installation

This motherboard comes with a retention module attached on the CPU socket when shipped, we strongly recommend you to install AOpen special designed CPU Fan as shown below on the retention module for better heat dissipation. Please install the CPU Fan correctly as the following pictures shown.

1. Gently put the CPU Fan down on the retention module with clips aligning correctly to the four corners.

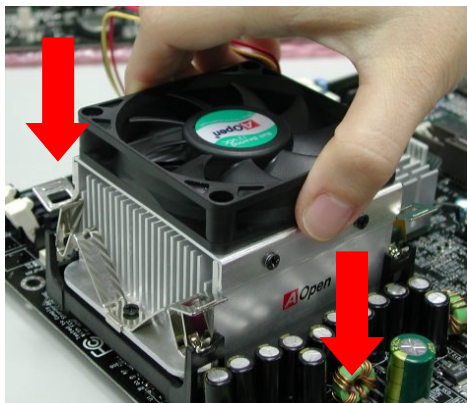

2. Pressing down the four clips with force one by one on the retention module.

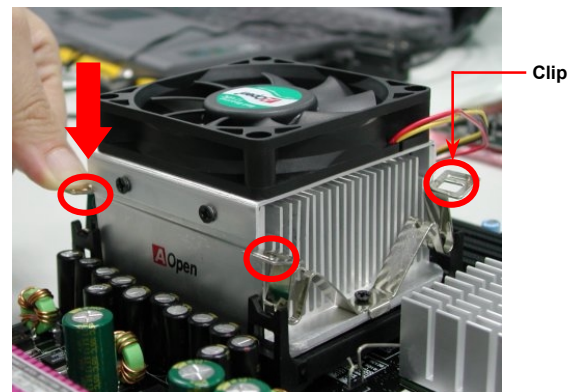

Note: This picture is for example only; it may not look the same with the motherboard you purchased.

CPU Jumper-less Design

CPU VID signal and [SMBus](#) clock generator provide CPU voltage auto-detection and allows the user to set the CPU frequency through the [BIOS setup](#), therefore no jumpers or switches are used. The disadvantages of the Pentium based jumper-less designs are eliminated. There will be no worry of wrong CPU voltage detection.

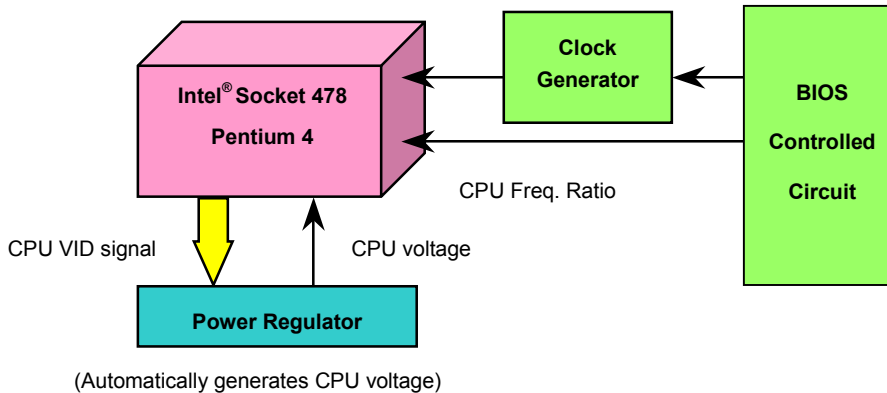

AOpen “Watch Dog Timer”



AOpen provides a special and useful feature on this motherboard for overclockers. When you power-on the system, the BIOS will check last system [POST](#) status. If it succeeded, the BIOS will enable “Watch Dog Timer” function immediately, and set the CPU [FSB](#) frequency according to user’s settings stored in the BIOS. If system failed in BIOS POST, the “Watch Dog Timer” will reset the system to reboot in five seconds.

Then, BIOS will detect the CPU’s default frequency and POST again. With this special feature, you can easily overclock your system to get a higher system performance without removing the system housing and save the hassle from setting the jumper to clear CMOS data when system hangs.

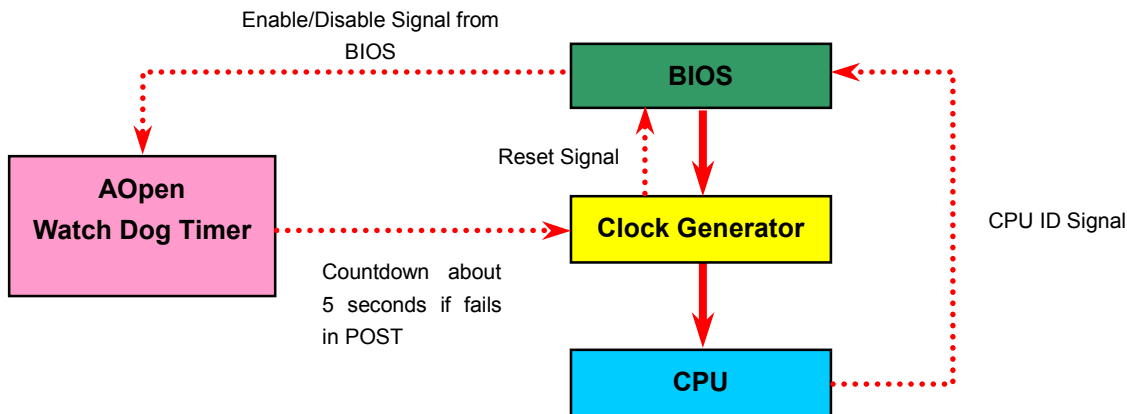

Full-range Adjustable CPU Core Voltage

This function is dedicated to overclockers and supports Adjustable CPU Core Voltage from 1.10V to 1.85V. However, this motherboard can also automatically detect CPU VID signal and generate proper CPU core voltage.

Setting CPU Frequency

BIOS Setup > Frequency/Voltage Control > CPU Clock Setting

This motherboard is CPU jumper-less design, you can set CPU frequency through the BIOS setup, and no jumpers or switches are needed. The default setting is "table select mode". You can adjust the FSB from "CPU Host/SDRAM/PCI Clock" for overclocking.

Core Frequency = CPU FSB Clock * CPU Ratio

PCI Clock = CPU FSB Clock / Clock Ratio

AGP Clock = PCI Clock x 2

CPU Ratio	8x, 10x... 21x, 22x, 23x, 24x
CPU FSB (By BIOS table)	100 and 133 MHz

AX4GE Tube / AX4PE Tube

Northwood CPU	CPU Core Frequency	FSB Clock	System Bus	Ratio
Pentium 4 1.6G	1600MHz	100MHz	400MHz	16x
Pentium 4 1.6G	1600MHz	133MHz	533MHz	12x
Pentium 4 1.7G	1700MHz	133MHz	533MHz	13x
Pentium 4 1.8G	1800MHz	100MHz	400MHz	18x
Pentium 4 2.0G	2000MHz	100MHz	400MHz	20x
Pentium 4 2.2G	2200MHz	100MHz	400MHz	22x
Pentium 4 2.26G	2260MHz	133MHz	533MHz	17x
Pentium 4 2.4G	2400MHz	100MHz	400MHz	24x
Pentium 4 2.4G	2400MHz	133MHz	533MHz	18x
Pentium 4 2.53G	2530MHz	133MHz	533MHz	19x
Pentium 4 2.66G	2660MHz	133MHz	533MHz	20x
Pentium 4 2.8G	2800MHz	133MHz	533MHz	21x

Warning: Intel 845GE/PE chipset supports maximum 400MHz (100MHz*4) / 533MHz (133MHz*4) system bus and 66MHz AGP clock; higher clock setting may cause serious system damage.

Online Manual

Willamette CPU	CPU Core Frequency	FSB Clock	System Bus	Ratio
Pentium 4 1.5G	1500MHz	100MHz	400MHz	15x
Pentium 4 1.6G	1600MHz	100MHz	400MHz	16x
Pentium 4 1.7G	1700MHz	100MHz	400MHz	17x
Pentium 4 1.8G	1800MHz	100MHz	400MHz	18x
Pentium 4 1.9G	1900MHz	100MHz	400MHz	19x
Pentium 4 2.0G	2000MHz	100MHz	400MHz	20x

Celeron CPU	CPU Core Frequency	FSB Clock	System Bus	Ratio
1.7G	1700MHz	100MHz	400MHz	17x
1.8G	1800MHz	100MHz	400MHz	18x

Note: Since the latest processor, Northwood, would detect the clock ratio automatically, you may not be able to adjust the clock ratio in BIOS manually.

CPU and System Fan Connector (with H/W Monitoring)

Plug in the CPU fan cable to the 3-pin **CPUFAN1** connector. If you have chassis fan, you can also plug it on **SYSFAN2** or **SYSFAN3** connector.

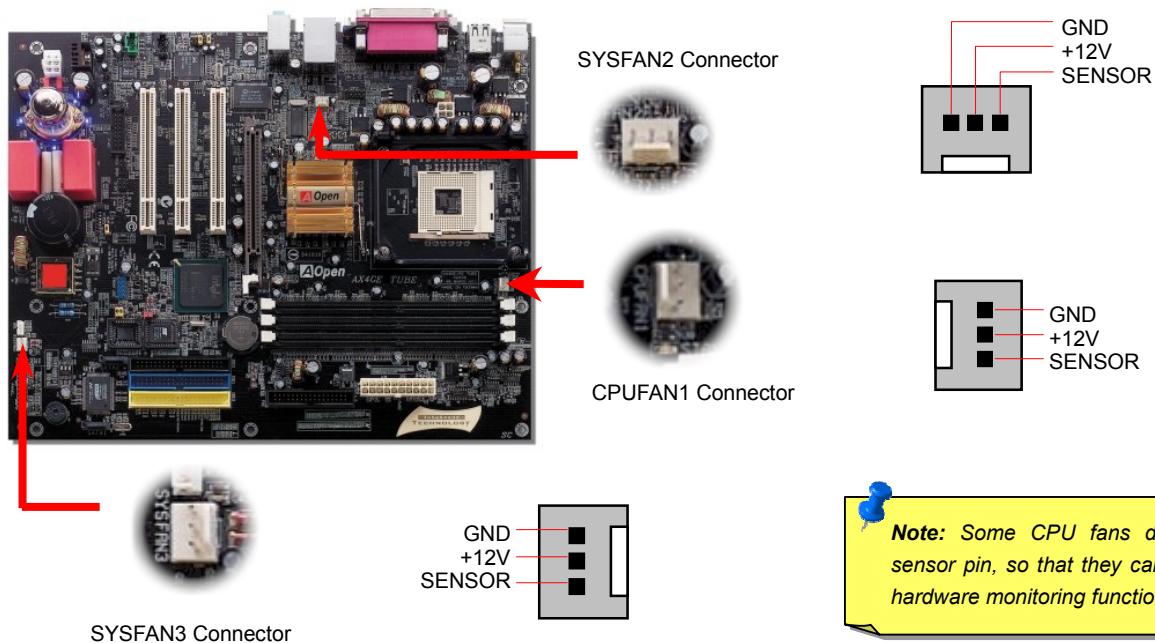

Note: Some CPU fans do not have sensor pin, so that they cannot support hardware monitoring function.

DIMM Sockets and Memory Adjustable Voltage

This motherboard has three 184-pin DDR [DIMM](#) sockets that allow you to install [PC1600](#) (DDR200), [PC2100](#) (DDR266) or [PC2700](#) (DDR333) memory up to 2GB. To have better and stable performance of the memory, we also provide several options of memory voltages for you to choose. You can setup an appropriate voltage with a range between 2.50V and 2.70V in BIOS.

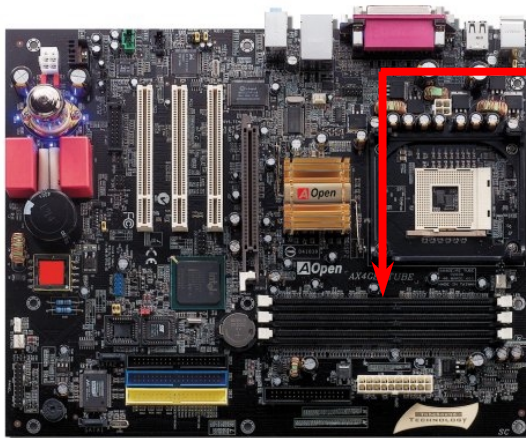

DIMM1
DIMM2
DIMM3

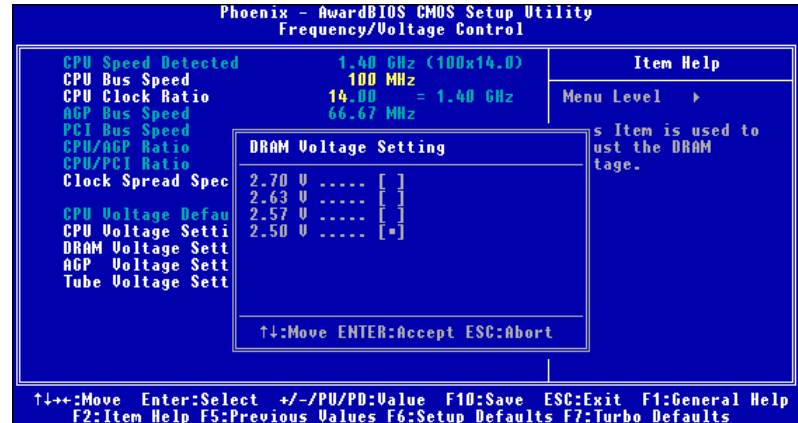

How to Install Memory Modules

Please follow the procedure as shown below to finish memory installation.

1. Make sure the DIMM module's pin face down and match the socket's size as depicted below.

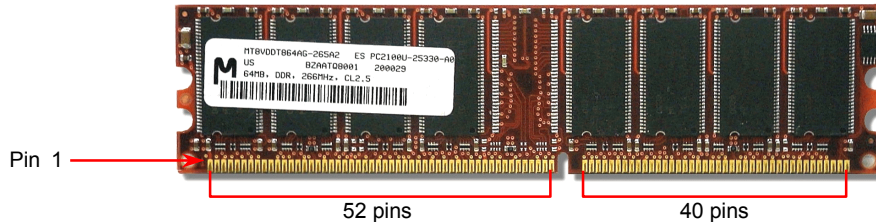

2. Insert the module straight down to the DIMM slot with both hands and press down firmly until the DIMM module is securely in place.

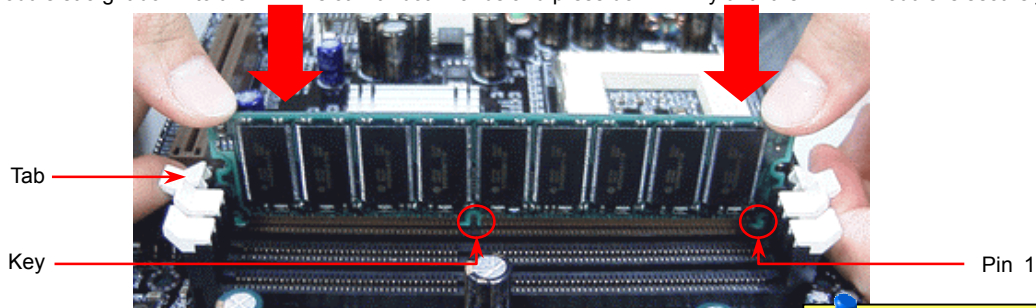

3. Repeat step 2 to finish additional DIMM modules installation.

Note: This picture is for example only; it may not look the same with the motherboard you purchased.

Note: The tabs of the DIMM slot will close-up to hold the DIMM in place when the DIMM touches the slot's bottom.

DDR 266(PC2100) and DDR 333(PC2700)

DDR SDRAM utilizes the existing SDRAM infrastructure and technology while doubling the nominal bandwidth available to systems. To put it in a simple way, DDR SDRAM is like data going along a two lane highway, while at the same time data in traditional SDRAM go along a one way street. Therefore, it is a more advanced technology that provides a great overall improvement in system performance. DDR266 (PC2100) runs two times faster than the traditional PC133 SDRAM with the speed of Front Side Bus (FSB) up to 266MHz. ($2 \times 133 = 266$). And DDR333 (PC2700) is running at 333MHz FSB. Both PC2100 and PC2700 are a new naming standard for speed of DDR 266 and DDR 333, representing their theoretical speeds of the RAM. The theoretical transfer rate of DDR 266 (PC2100) is 2.1GB/s and 2.7GB/s is for DDR 333 (PC2700).

Front Panel Connector

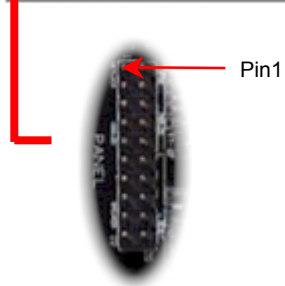

Attach the power LED, Keylock, speaker, power and reset switch connectors to the corresponding pins. If you enable “Suspend Mode” item in BIOS Setup, the ACPI & Power LED will keep flashing while the system is in suspend mode.

Locate the power switch cable from your ATX housing. It is 2-pin female connector from the housing front panel. Plug this connector to the soft-power switch connector marked **SPWR**.

Suspend Type	ACPI LED
Power on Suspend (S2) or Suspend to RAM (S3)	Flashing for every second
Suspend to Disk (S4)	The LED will be turned off

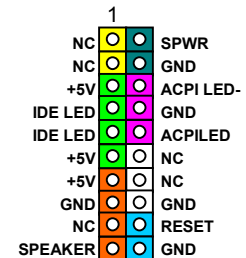
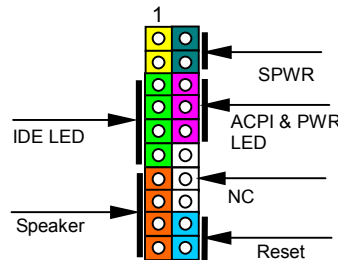

ATX Power Connector

This motherboard comes with a 20-pin and 4-pin ATX power connector. Make sure you plug in the right direction. We strongly recommend you to connect the 4-pin 12V ATX connector before connecting the 20-pin ATX power connector and use standard power supply specially designed for Pentium 4 system.

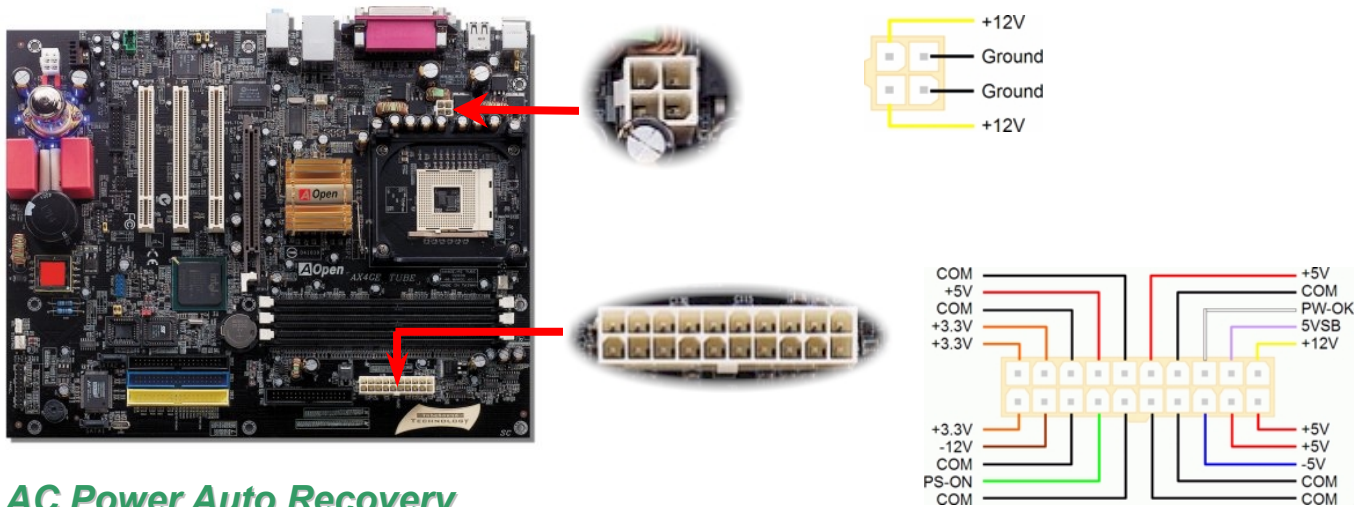

AC Power Auto Recovery

A traditional ATX system should remain at power off stage when AC power resumes from power failure. This design is inconvenient for a network server or workstation, without an UPS, that needs to keep power-on. This motherboard implements an AC Power Auto Recovery function to solve this problem.



STBY LED (Standby LED) and BOOT LED

Both STBY LED and BOOT LED are AOpen's considerate designs that we aim at providing you friendly system information. The STBY LED will light up when power is provided to the motherboard. This is a convenient indication for you to check the system power status in many circumstances such as power on/off, stand-by mode and RAM power status during [Suspend to RAM mode](#).

BOOT LED will keep blinking when you power the system on and when your system is under [POST \(Power-On Self Test\)](#). After POST diagnoses everything alright and finishes the booting, the LED will stay on otherwise it will remain flashing to warn you that mistakes have occurred during POST.

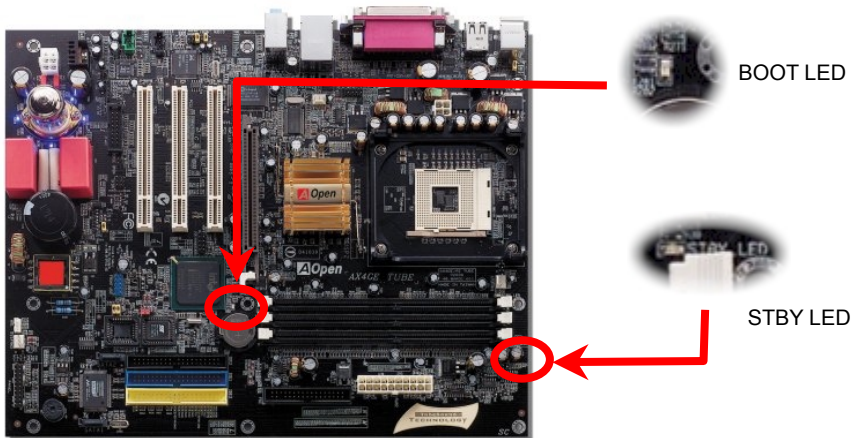

IDE and Floppy Connector

Connect 34-pin floppy cable and 40-pin, 80-wire IDE cable to floppy connector FDC and IDE connector. Be careful of the pin1 orientation. Wrong orientation may cause system damage.

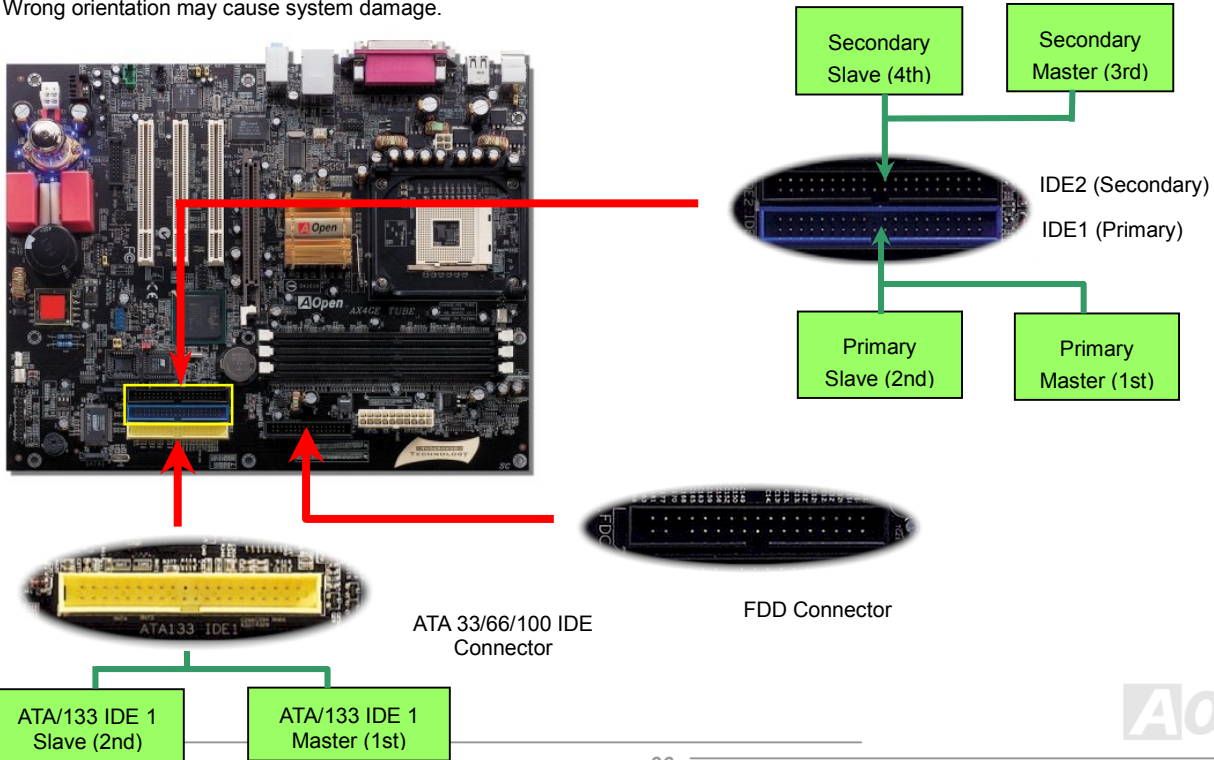

IDE1 is also known as the primary channel and IDE2 as the secondary channel. Each channel supports two IDE devices that make a total of four devices. In order to work together, the two devices on each channel must be set differently to **Master** and **Slave** mode. Either one can be the hard disk or the CDROM. The setting as master or slave mode depends on the jumper on your IDE device, so please refer to your hard disk and CDROM manual accordingly.



Tip:

1. For better signal quality, it is recommended to set the far end side device to master mode and follow the suggested sequence to install your new device. Please refer to above diagram
2. To achieve the best performance of Ultra DMA 66/100/133 hard disks, a special **80-wires IDE cable** for Ultra DMA 66/100/133 is required.



Warning: The specification of the IDE cable is a maximum of 46cm (18 inches); make sure your cable does not exceed this length.



ATA/133 Supported

This motherboard supports [ATA66](#), [ATA100](#) or [ATA133](#) IDE devices. Following table lists the transfer rate of IDE PIO and DMA modes. The IDE bus is 16-bit, which means every transfer is two bytes. As the hard drive industry introduces faster and higher capacity hard drives, the current Ultra ATA/100 interface causes a data bottleneck between the drive and the host computer. To avoid this problem, hard disk manufactures have introduced the new Ultra ATA-133 interface technology. Compared to traditional ATA/100, ATA/133 has up to 33 percent increase in interface speed with transfer rate of 133MB/s. ATA/133 performance is ideal for new operating systems, such as Window XP, that demand more storage space and faster data transfer rates from more responsive computing experiences.

To make good use of this new technology and enjoy its best performance, we recommend you to pair your system with a hard disk equipped with ATA/133 technology so that your system's need for speed on this motherboard can be satisfied.

Mode	Clock Period	Clock Count	Cycle Time	Data Transfer Rate
PIO mode 0	30ns	20	600ns	$(1/600\text{ns}) \times 2\text{byte} = 3.3\text{MB/s}$
PIO mode 1	30ns	13	383ns	$(1/383\text{ns}) \times 2\text{byte} = 5.2\text{MB/s}$
PIO mode 2	30ns	8	240ns	$(1/240\text{ns}) \times 2\text{byte} = 8.3\text{MB/s}$
PIO mode 3	30ns	6	180ns	$(1/180\text{ns}) \times 2\text{byte} = 11.1\text{MB/s}$
PIO mode 4	30ns	4	120ns	$(1/120\text{ns}) \times 2\text{byte} = 16.6\text{MB/s}$
DMA mode 0	30ns	16	480ns	$(1/480\text{ns}) \times 2\text{byte} = 4.16\text{MB/s}$
DMA mode 1	30ns	5	150ns	$(1/150\text{ns}) \times 2\text{byte} = 13.3\text{MB/s}$
DMA mode 2	30ns	4	120ns	$(1/120\text{ns}) \times 2\text{byte} = 16.6\text{MB/s}$
ATA 66	30ns	2	60ns	$(1/60\text{ns}) \times 2\text{byte} \times 2 = 66\text{MB/s}$
ATA 100	20ns	2	40ns	$(1/40\text{ns}) \times 2\text{byte} \times 2 = 100\text{MB/s}$
ATA 133	15ns	2	30ns	$(1/30\text{ns}) \times 2\text{byte} \times 2 = 133\text{MB/s}$



Serial ATA Supported



This motherboard comes with a Promise Serial ATA (PDE20375) controller, aiming to provide you an even faster transfer rate of 150 Mbytes/second. The traditional parallel ATA specification has defined the standard storage interface for PCs with its original speed of just 3 Mbytes/second since the protocol was introduced in the 1980s. And the latest generation of the interface, Ultra ATA-133, has been developed further with a burst data transfer rate of 133 Mbytes/second. However, while ATA has enjoyed an illustrious track record, the specification is now showing its age and imposes some serious design issues on today's developers, including a 5-volt signaling requirement, high pin count, and serious cabling headaches.

The Serial ATA specification is designed to overcome these design limitations while enabling the storage interface to scale with the growing media rate demands of PC platforms. Serial ATA is to replace parallel ATA with the compatibility with existing operating systems and drivers, adding performance headroom for years to come. It reduces voltage and pin count requirements and can be implemented with thin and easy to route cables.

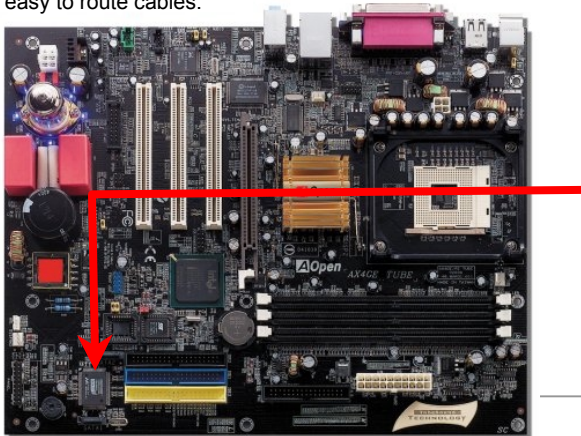

Serial ATA Controller



Connecting Serial ATA Disk

To connect a Serial ATA disk, you have to have a 7-pin serial ATA cable. Connect two ends of the serial ATA cable to the serial ATA header on the mainboard and the disk. Like every other traditional disk, you also have to connect a power cable. Please note that it is a jumper free implement; you don't need to set jumpers to define a master or slave disk. When connecting two serial ATA disks, the system will automatically take the one connected to "Serial ATA 1" header as a master disk.

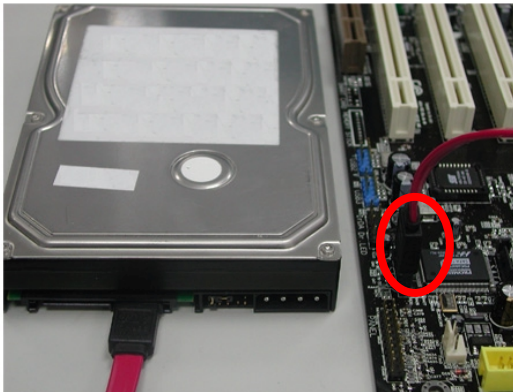

Comparison between Parallel ATA and Serial ATA

	Parallel ATA	Serial ATA
Bandwidth	100/133 MB/Secs	150/300/600 MB/Secs
Volts	5V	250mV
Pins	40	7
Length Limitation	18 inch (45.72cm)	1 meter (100cm)
Cable	Wide	Thin
Ventilation	Bad	Good
Peer-to-Peer	No	Yes

Note: This picture is for example only; it may not look the same with the motherboard you purchased.

IrDA Connector

The IrDA connector can be configured to support wireless infrared module, with this module and application software such as Laplink or Windows 95 Direct Cable Connection, the user can transfer files to or from laptops, notebooks, PDA devices and printers. This connector supports HPSIR (115.2Kbps, 2 meters) and ASK-IR (56Kbps).

Install the infrared module onto the IrDA connector and enable the infrared function from BIOS Setup, UART Mode, make sure to have the correct orientation when you plug in the IrDA connector.

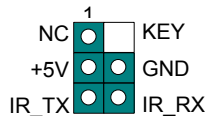

Pin 1

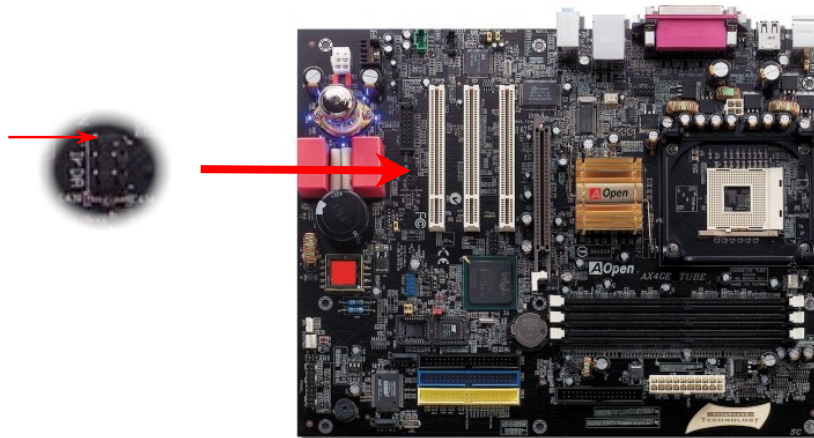

AGP (Accelerated Graphic Port) Expansion Slot and Adjustable Voltage

AX4GE Tube / AX4PE Tube provides an [AGP](#) 4x slot. The AGP 4x is a bus interface targeted for high-performance 3D graphic. AGP supports only memory read/write operation and single-master single-slave one-to-one only. AGP uses both rising and falling edge of the 66MHz clock, for 2X AGP, the data transfer rate is 66MHz x 4bytes x 2 = 528MB/s. AGP is now moving to AGP 4x mode, 66MHz x 4bytes x 4 = 1056MB/s. Same as memory adjustable voltage, you can also adjust a suitable AGP voltage in BIOS to obtain better performance of you AGP.

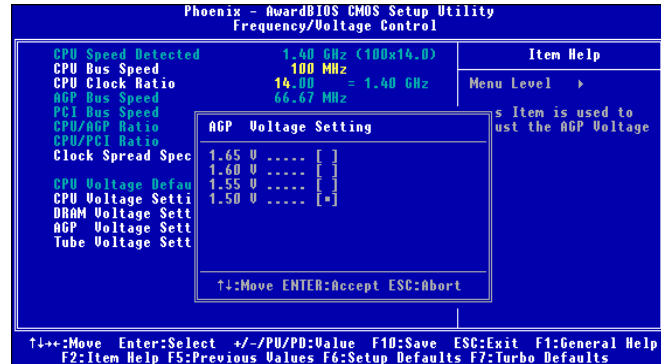
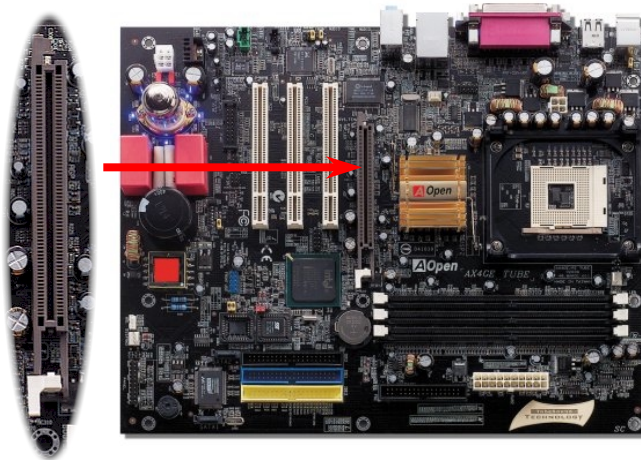

AGP Protection Technology and AGP LED

With the outstanding R&D ability of AOpen and its specially developed circuit, AX4GE Tube / AX4PE Tube implements a brand new technology to protect your motherboard from being damaged by over-voltaging of AGP card. When AGP Protection Technology is implemented, this motherboard will automatically detect the voltage of AGP card and prevent your chipsets from being burnt out. Please note that if you install a AGP card with 3.3V, which is not supported by Intel 845GE/PE, the AGP LED on the motherboard will light up to warn you the possible damage of the exceeding voltage. You may contact your AGP card vendor for further support.

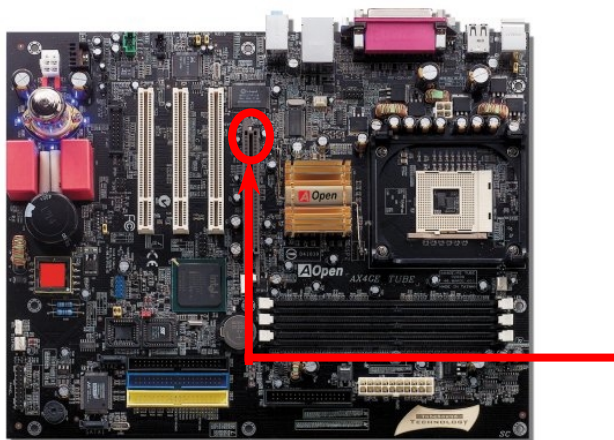

AGP LED

Warning: It is strongly recommended not to install a 3.3V AGP card, which is not supported by Intel 845GE/PE. When you do so, the LED3 on the motherboard will light up to warn you the possible damage.

WOL (Wake on LAN)

To use Wake On LAN function, you must have a network card with chipset that supports this feature, and connect a cable from LAN card to motherboard WOL connector. The system identification information (probably IP address) is stored on network card and because there is a lot of traffic on the Ethernet, you need to install network management software, such as ADM, for the checking of how to wake up the system. Note that, at least 600mA ATX standby current is required to support the LAN card for this function.

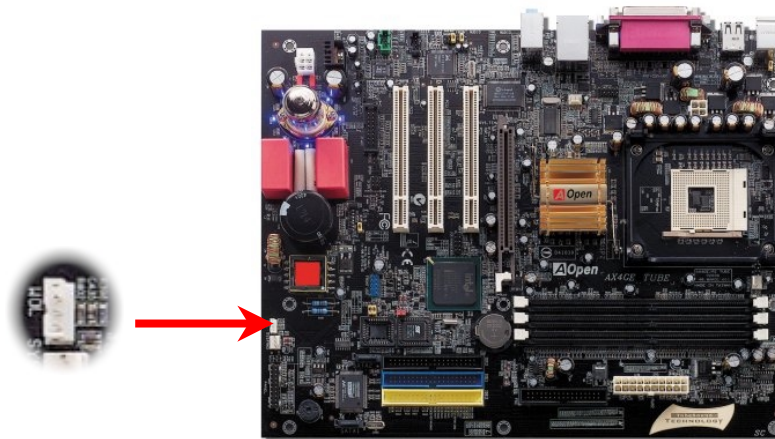
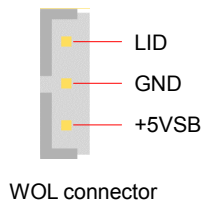

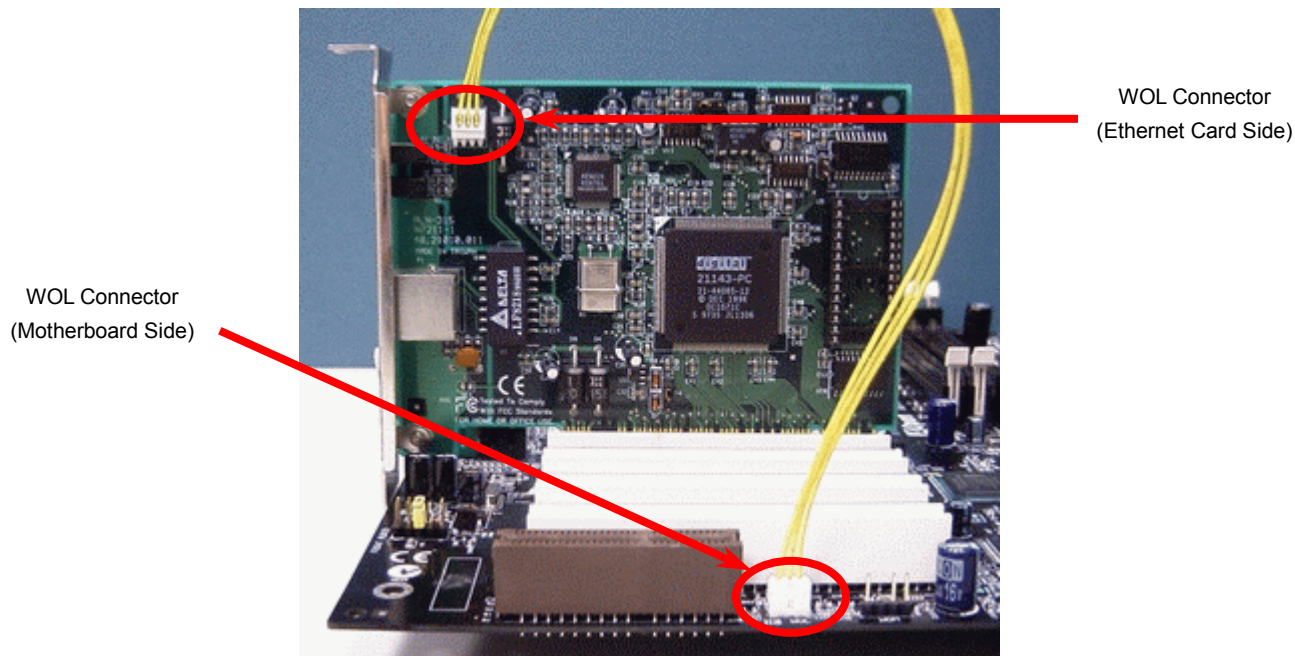

Note: This picture is for example only; it may not exactly look the same with the motherboard you purchased.

Game Port Bracket Supported

This motherboard comes with a game port (Joystick-Midi) for you to connect any midi devices or joysticks. To use this function you have to have a joystick module and connect it with a game port cable to this port on the motherboard.

Joystick Module
(User Upgrade Optional)

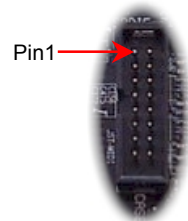

JST-MIDI Port



1	●	●	+5V	●	●	+5V
	●	●	JAB1	●	●	JBB1
	●	●	JACX	●	●	JBCX
	●	●	GND	●	●	MIDI_TXD
	●	●	GND	●	●	JBCY
	●	●	JACY	●	●	JBB2
	●	●	JAB2	●	●	MIDI_RXD
	●	□	+5V	●	●	KEY

Note: This picture is for example only; it may not exactly look the same with the motherboard you purchased.

Support 10/100 Mbps LAN onboard

On the strength of Intel ICH4 on board, it provides 10/100M bps Ethernet for office and home use, the Ethernet RJ45 connector is located on top of USB connectors. The green LED indicates the link mode, it lights when linking to network and blinking when transferring data. The orange LED indicates the transfer mode, and it lights when data is transferring in 100Mbps mode. To enable or disable this function, you may simply adjust it through BIOS.

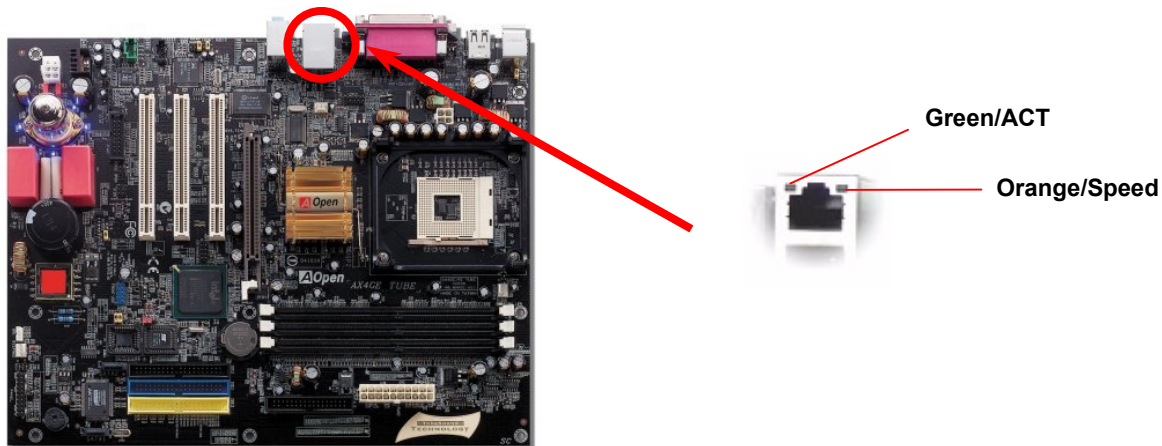

JP28 Keyboard/Mouse Wake-up Jumper

This motherboard provides PS2 keyboard / mouse wake-up function. You can use JP28 to enable or disable this function, which could resume your system from suspend mode with keyboard or mouse. The factory default setting is set to "Disable"(1-2), and you may enable this function by setting the jumper to 2-3.

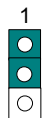
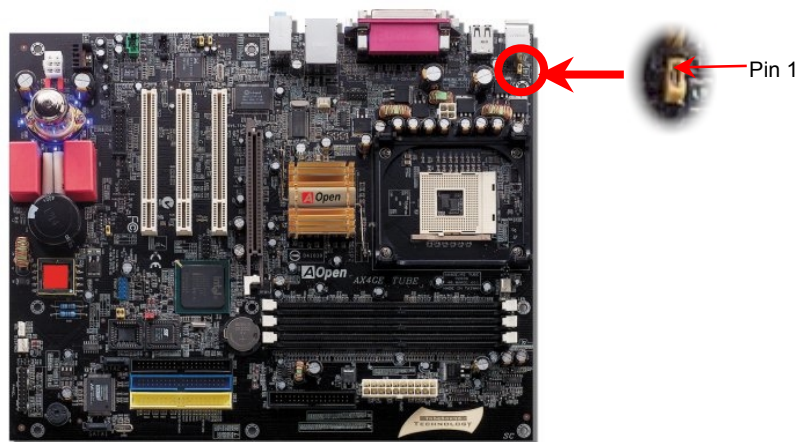

Disable
(Default)



Enable

Die-Hard BIOS and JP24 Die-Hard BIOS Select Jumper

Many viruses have been found that they may destroy bios code and data area lately. This motherboard implements a very effective hardware protection method without any software or BIOS coding involved, therefore it is 100% virus free. You may restore the originally mounted BIOS with 2nd BIOS ROM by setting JP24 to pin 2-3 if it fails to work properly. This motherboard comes with one BIOS ROM, you may contact our local distributors or resellers for purchasing an extra BIOS ROM. Please visit our website at www.aopen.com for details.



Normal



Rescue

JP24 Pin1

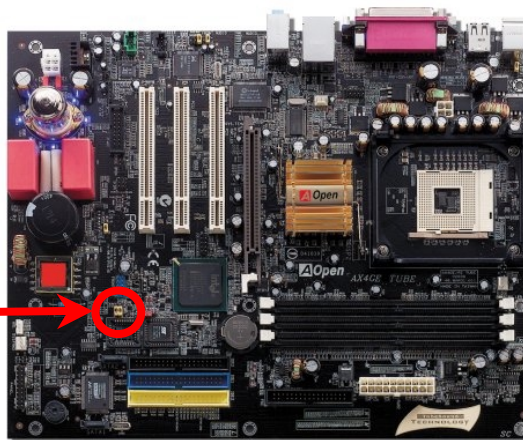

PC99 Color Coded Back Panel

The onboard I/O devices are PS/2 Keyboard, PS/2 Mouse, RJ-45 LAN Connector, COM1, VGA port, Printer, [USB](#), and AC97 sound port. The view angle of drawing shown here is from the back panel of the housing.

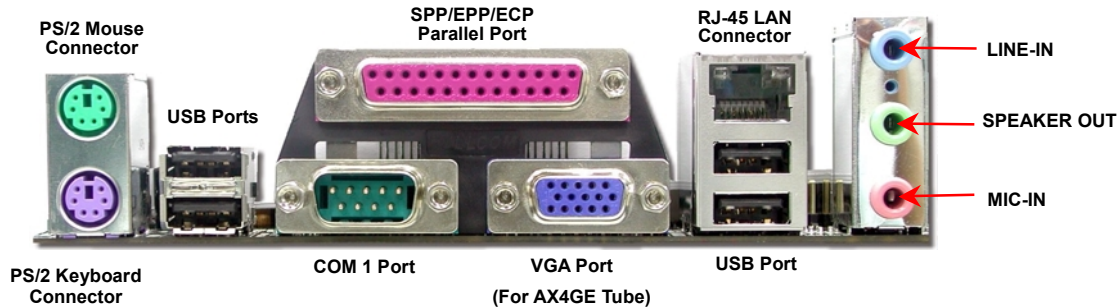

PS/2 Keyboard:	For standard keyboard, which is using a PS/2 plug.
PS/2 Mouse:	For PC-Mouse, which is using a PS/2 plug.
USB Port:	Available for connecting USB devices.
Parallel Port:	To connect with SPP/ECP/EPP printer.
COM1/COM2 Port:	To connect with pointing devices, modem or others serial devices.
RJ-45 LAN connector	To connect Ethernet for home or office use.
VGA Connector:	To connect with PC monitor.
Speaker Out:	To External Speaker, Earphone or Amplifier.
Line-In:	Comes from the signal sources, such as CD/Tape player.
MIC-In:	From Microphone.
MIDI/Game Port:	For 15-pin PC joystick, game pad or MIDI devices.

Support 2nd USB 2.0 Ports



This motherboard provides six [USB](#) ports to connect USB devices such as mouse, keyboard, modem, printer, etc. There is one USB connector on the board for you to connect two USB devices and four other ports on the back panel. You can use proper cables to connect USB devices from PC99 back panel or connect the front USB connector to the front panel of chassis.

Compared to traditional USB 1.0/1.1 with the speed of 12Mbps, USB 2.0 has a fancy speed up to 480Mbps which is 40 times faster than the traditional one. Except for the speed increase, USB 2.0 supports old USB 1.0/1.1 software and peripherals, offering impressive and even better compatibility to customers. On this motherboard, all six ports support USB 2.0 function.

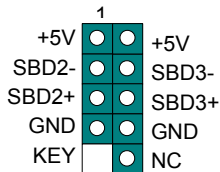

Pin1

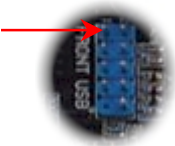

USB2.0 Connector

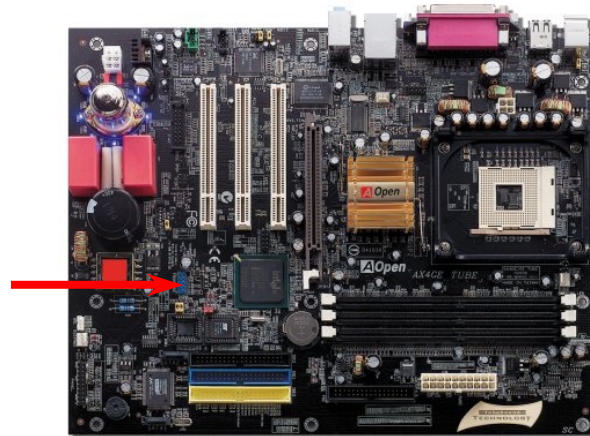

Case Open Connector

The “CASE OPEN” header provides chassis intrusion-monitoring function. To make this function works, you have to enable it in the system BIOS, connect this header to a sensor somewhere on the chassis. So, whenever the sensor is triggered by lights or by the opening of the chassis, the system will beep to inform you. Please be informed that this useful function only applies to advanced chassis, you may purchase an extra sensor, attach it on your chassis, and make a good use of this function.

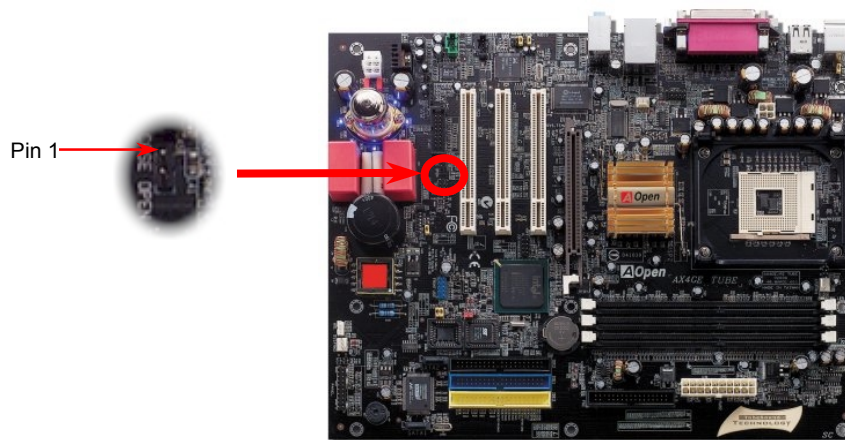
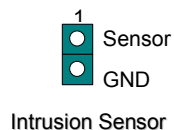

CD Audio Connector

This connector is used to connect CD Audio cable from CDROM or DVD drive to onboard sound.

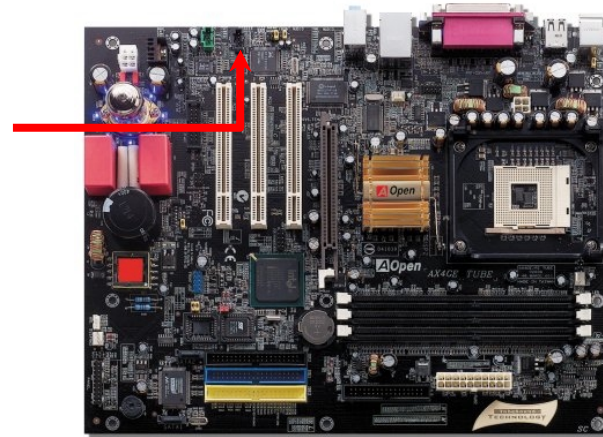
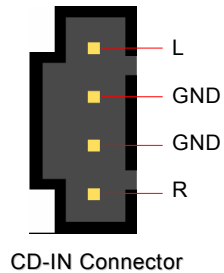

Note: Though some of the Windows versions support "Digital Audio" through IDE bus. However, in order to use Open Jukebox player, which is driven under BIOS, it is a **MUST** to connect audio cable to CD-IN connector on the motherboard.

AUX-IN Connector

This **GREEN** connector is used to connect MPEG Audio cable from MPEG card to onboard sound.

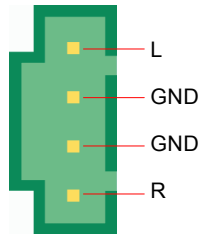

AUX-IN Connector

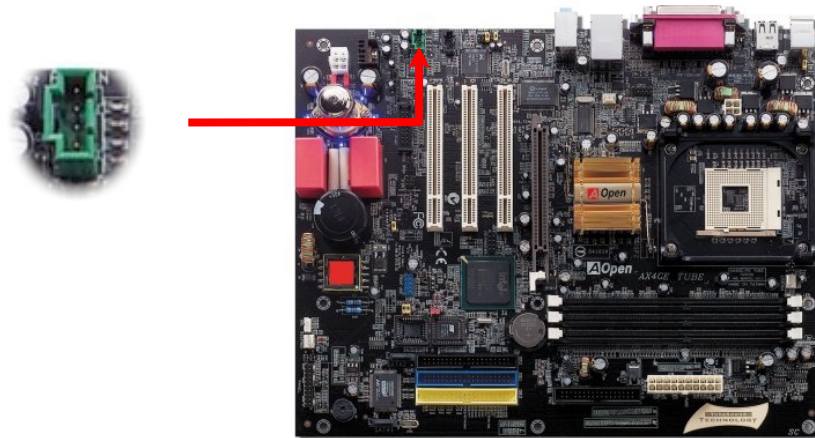

COM2 Connector

This motherboard provides two serial ports. One of them is on back panel connector, and the other is on the lower part of the board. With proper cable, you can connect it to the back panel of chassis.

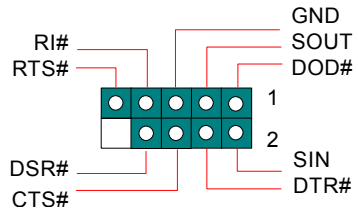
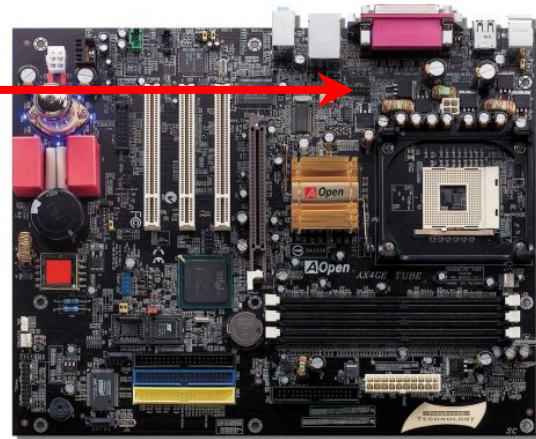
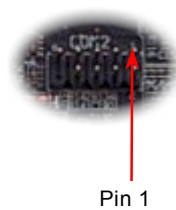

Front Audio Connector

If the housing has been designed with an audio port on the front panel, you'll be able to connect onboard audio to front panel through this connector. By the way, please remove the jumper cap from the Front Audio Connector before you connect the cable. Do not remove this yellow jumper cap if your housing doesn't have an audio port on the front panel.

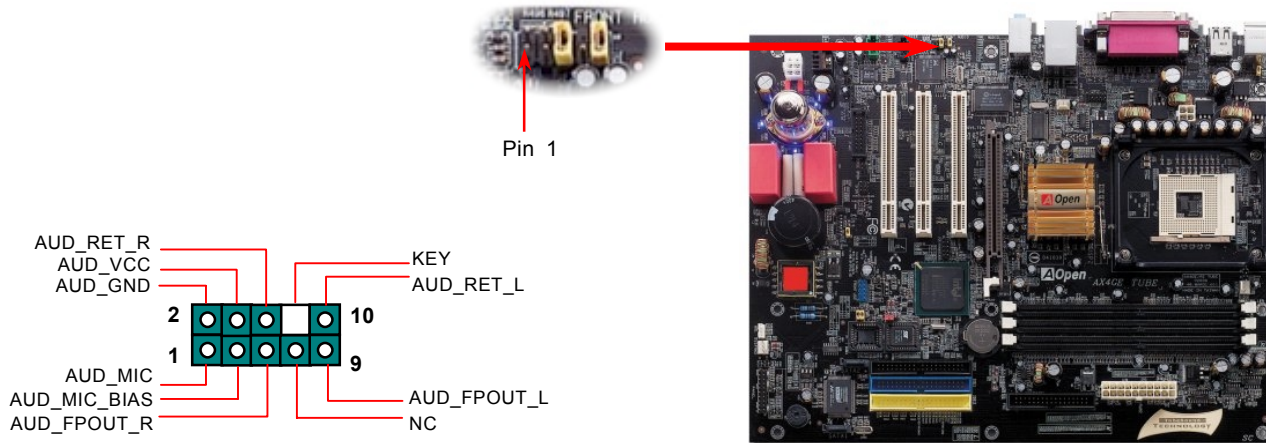

Note: Please remove the jumper cap from the front audio connector before you connect the cable. Do not remove this yellow jumper cap if your housing doesn't have an audio port on the front panel.

Tube Related components



To provide audiophiles excellent audio effect on the computer system, this motherboard is equipped with a Vacuum Tube. You may find its related component as shown below. For the detail information of tube installation or other related components, please refer to Tube Manual.



Sovtek 6922 Tube and Tube Base



WIMA Hi-End Audio Grade Capacitor

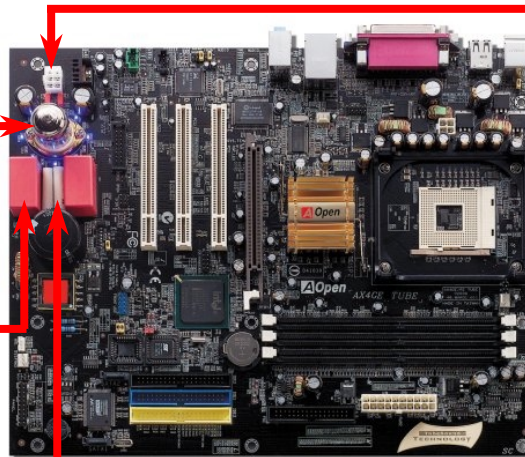

Audio Cable Connector

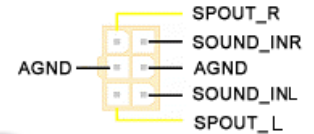

MultiCap Hi-End Audio Grade Capacitor

Note: For Vacuum Tube details, please refer to our specially made Tube Manual.



JP3 Tube Power Jumper



This JP3 jumper allows you to switch on/off power supply for Vacuum Tube. You may switch the power off whenever you are not using Tube as your audio output in order to save the power.

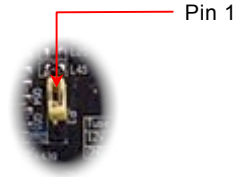
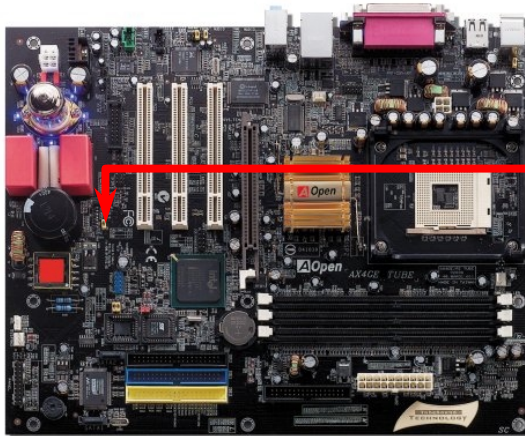

JP3 Tube Power

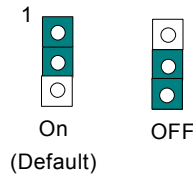

Note: For details of Vacuum Tube, please refer to our specially made Tube Manual.





S/PDIF (Sony/Philips Digital Interface) Connector

S/PDIF (Sony/Philips Digital Interface) is a latest audio transfer file format that provides impressive quality through optical fiber and allows you to enjoy digital audio instead of analog. Normally there are two S/PDIF outputs as shown, one for RCA connector, the most common one used for consumer audio products, and the other for optical connector with a even better audio quality. Through a specific audio cable, you can connect the S/PDIF connector to a S/PDIF audio module bearing S/PDIF digital output. However, you must have a S/PDIF supported speaker with S/PDIF digital input to make the most of this function.

- 1 +5V
- NC
- SPDIFOUT
- GND
- 5 SPDIFIN

Pin 1

S/PDIF Connector

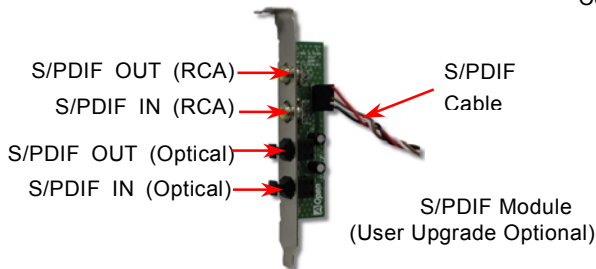
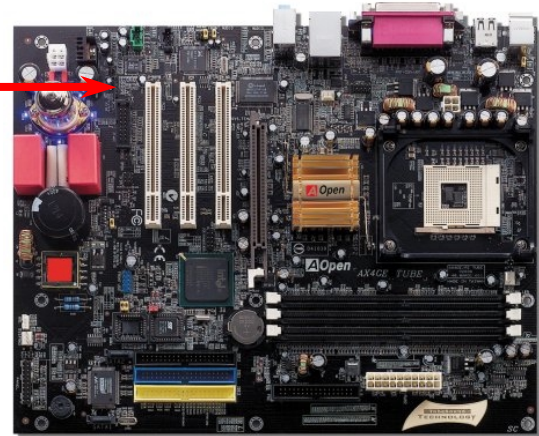

Super 5.1 Channel Audio Effect



This motherboard comes with an ALC650 CODEC which supports high quality of 5.1 Channel audio effect, bringing you a brand new audio experience. On the strength of the innovative design of ALC650, you're able to use standard line-jacks for surround audio output without connecting any external module. To apply this function, you have to install the audio driver in the Bonus Pack CD as well as an audio application supporting 5.1 Channel. Picture below represents the standard location of all speakers in 5.1 Channel sound track. Please connect the plug of your front speakers to the green "Speaker out" port, rear speakers' plug to the blue "Line in" port and both of the center and subwoofer speakers to the red "MIC in" port.

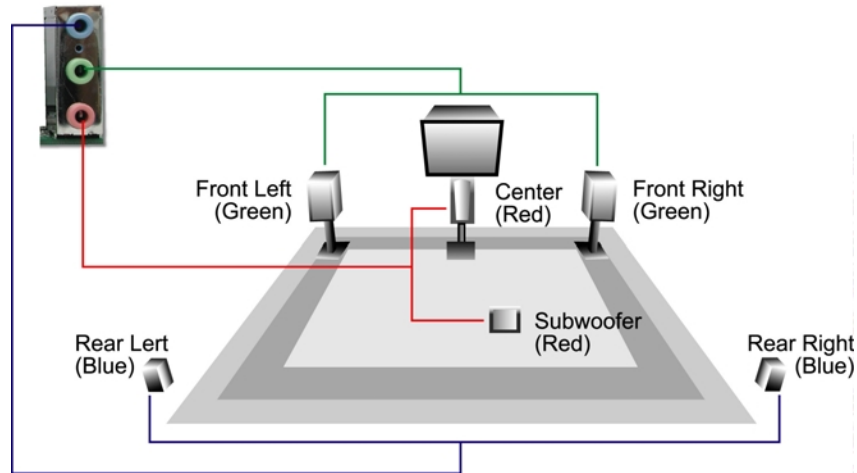



FM Radio Card Supported

Do you enjoy listening baseball live broadcast while playing your PC at the same time? Though you can connect few designated broadcasting channels through some small broadcasting utilities on your PC, there are always abominable problems such as the on and off listening quality, limitation of audience numbers and the long hours of connection to the broadcasting server. To solve the above hassles for our users, AOpen integrates the FM frequency radio function into a small piece of expansion card to allow you enjoy the exciting game broadcasts without missing any good moments. Even more, you can tape down any exciting pitch for later replay. To preserve the original sound of your programs, you can convert the .WAV format file into .MP3 file for the long term keeping. Besides, setting up to 10 of your favorite channels is as easy as normal radios. To be more considerate for our users, you may use JukeBox FM, integrated in our BIOS, to listen to radio without entering operation system after installing this FM Radio Expansion card. It's never been easier with FM Radio!

Installing FM Radio Card:

Please unplug your power cord before processing the following steps.

1. Unpack your FM Radio Card from the box
2. Connect the signal cable of the FM Radio Card to the FM header onboard

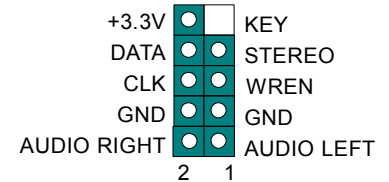
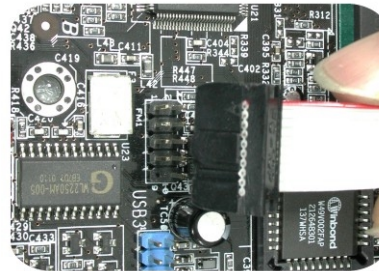
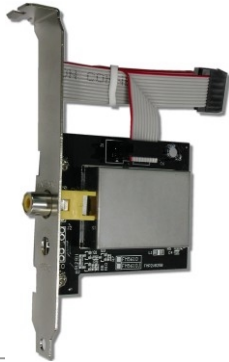

3. Connect the FM Radio Card onto the chassis.

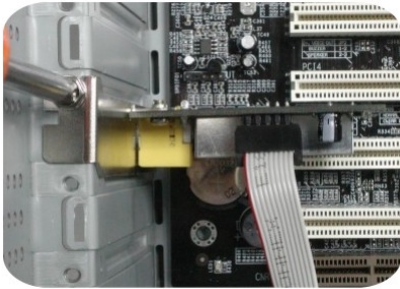

4. Connect antenna connector to expansion card port on the FM Radio Card.



5. Stretch the antenna out and place it securely.

Tip : Please use the audio antenna that comes along with this expansion card to get the best receiving quality.

Placing your PC at different places may have different receiving quality. Please adjust the angle of your antenna for the best receiving quality and stretch it out at its longest extent.

General speaking, it would be easier to receive clear frequency when you locate the antenna beside windows.

Installing FM Radio software:

After the hardware had been installed, you may reboot the system.

Please run the AOpen Bonus Pack CD after entering Window system.

An installation program will pop up automatically on the screen. Choose

FM Radio to start installation. You can also refer to the FM Radio

User Manual enclosed in the package for detailed illustration.



The noise is gone!! ---- SilentTek



As the clock of CPU keeps rocketing higher and higher, it inevitably brings higher heat and system temperature in a relative way. The way we deal with this heat problem, however, is to spare no effort to add one fan after another to protect our pampered system, expecting these fans could cool down our machine as much as it could.

But at the same time, we believe that same amount of users are affected terribly while working with their PC by the irritating noises of these fans. As a matter of fact, we do not have to get our fans running at such a high speed in most cases; on the

contrary, we discovered that having your fans running at appropriate time and speed could not only reduce the noise, but also consume the least power the system needed, so as to prevent over-wasting of energy resource.

Today, AOpen Motherboard is honored to bring you a new overall solution, SilentTek, to have your system quiet. To collocate with hardware circuit, BIOS and the utility under Windows, SilentTek combined "Hardware-Status Monitoring", "Overheat Warning" and "Fan Speed Control" with user-friendly interfaces to provide you a perfect balance between noises, system performance and stability.

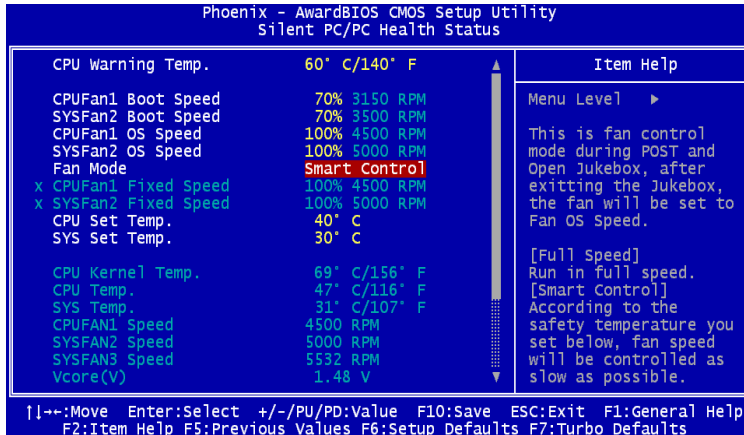

The first image you have here is the Voltage Status page. You can find current status of all voltages and set your expected margins of warning level.

In "Temp/Fan/Case" page, you may get aware of the current temperature of CPU and the heat inside chassis, plus checking if fans are running properly.

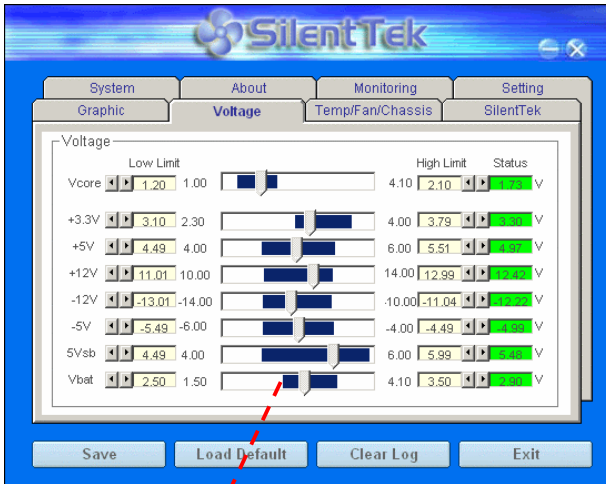

You may check your system voltage from the indicating bar here.

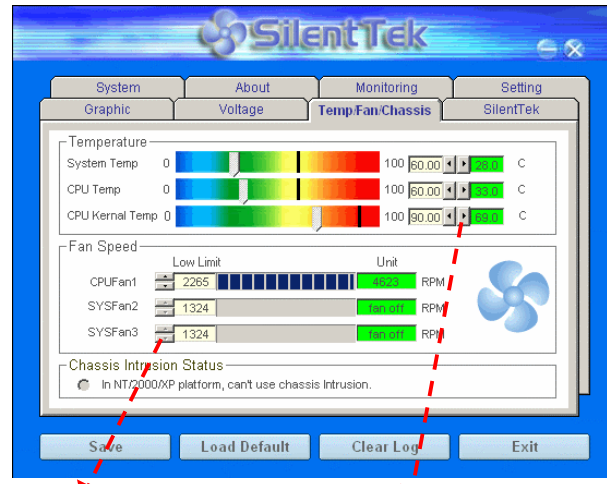

Of course, you may set your defaulted lowest margin for your fans and the SilentTek would also pop up a message box and alarm you when the fan is rotating slower than this specified speed.

You may set the highest margin of your CPU and system temperature as default, and SilentTek would pop up a message box and alert you with alarm when the temperature goes beyond the specified margin.

The following page is sure to be the most important part of this utility, you may control the rotation speed of specific fans you got with options inside in this page. Respectively illustrate as follow:



1. **Smart FAN Control:** This is the default setting of SilentTek and can be used for any branded computer housing. With a special algorithm developed by AOpen, the fan speed is automatically adjusted by the factors of CPU and ambient temperature. Ease-of-use and trouble free at your service.
2. **Fixed FAN Control:** Under this setting, a desired fan speed is set fixed when operating.
3. **Multiple Level Control:** This is the most versatile setting that allows you to set fan speed in relation to temperature. You may find this setting fits youbest.
4. **AOpen Recommend Setting:** This setting is designed specifically for AOpen housing. A series of lab tests were conducted under the real world scenario to determine optimum fan speed to reduce noise level within CPU working condition and temperature. Most of the time, the fan would remain still when CPU is not fully utilized.

Battery-less and Long Life Design

This Motherboard implements a [Flash ROM](#) and a special circuit that provide you no battery power consumption of current CPU and CMOS Setup configurations. The RTC (real time clock) can also keep running as long as the power cord is plugged. If you lose your CMOS data by accident, you can just reload the CMOS configurations from Flash ROM and the system will recover as usual.

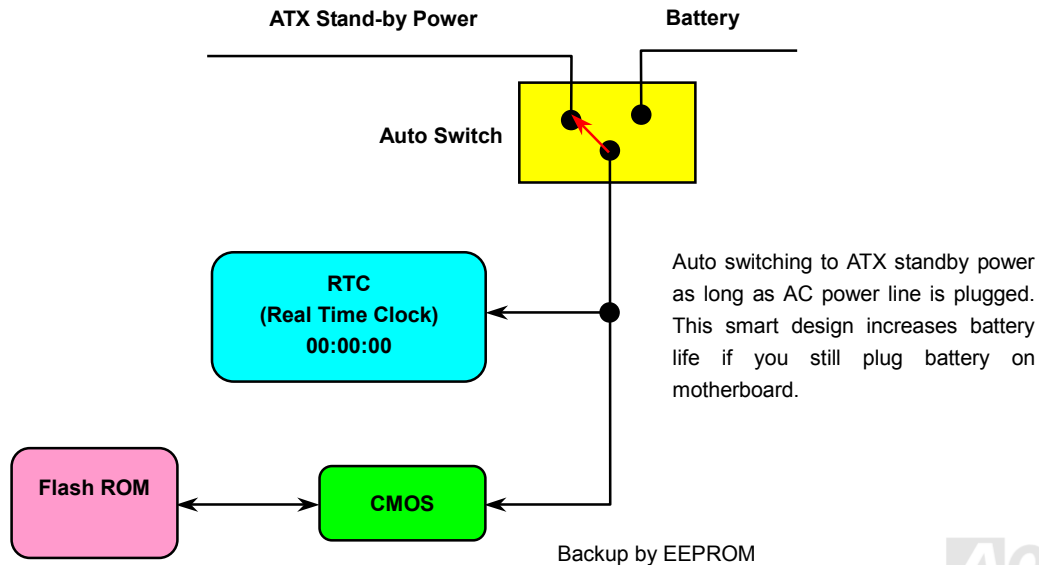

Over-current Protection

The Over Current Protection is a popular implementation on ATX 3.3V/5V/12V switching power supply. However, the new generation CPU uses different voltage with a regulator to transfer 12V to CPU voltage (for example, 2.0V), and thus makes 5V over current protection useless. This motherboard is with switching regulator onboard supporting CPU over-current protection; in conjunction with 3.3V/5V/12V power supply provide the full line over-current protection.

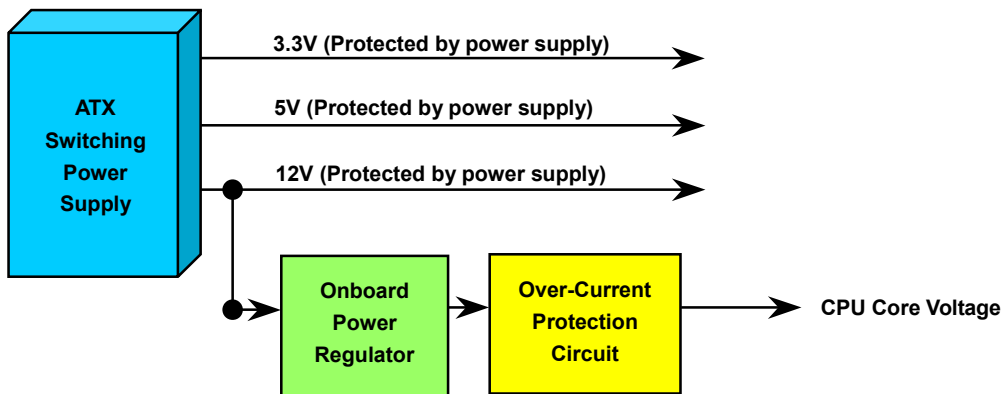

Note: Although we have implemented protection circuit and tried to prevent any human operating mistake, certain risks might still happen when CPU, memory, HDD or add-on cards installed on this motherboard is damaged due to component failure, human operating error or other unknown natural reasons. AOpen cannot guarantee that the protection circuit will always work perfectly.

Hardware Monitoring

This motherboard implements a hardware monitoring system. As you turn on your system, this smart design will monitor your system's working voltage, fan status and CPU temperature. If any of those systems' status goes wrong, there will be an alarm through the chassis external speaker or buzzer of motherboard (if having this function and enabled) to warn the user.

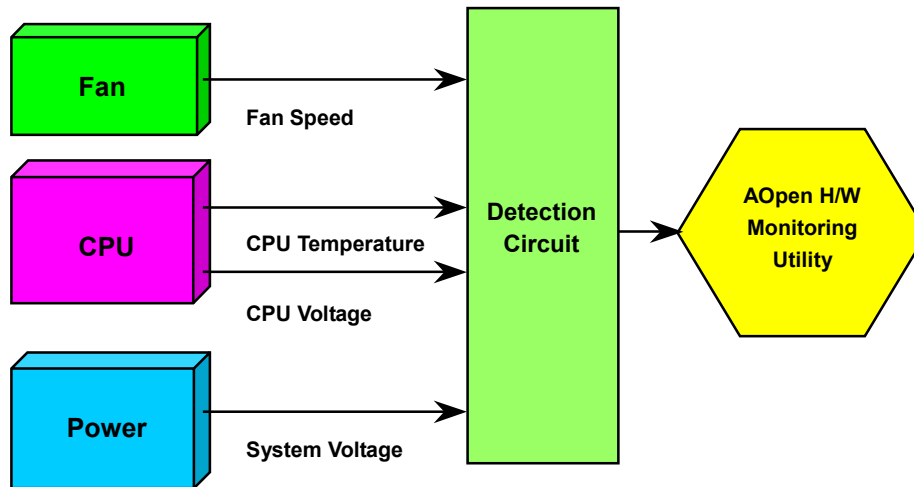

Resettable Fuse

Traditional motherboard uses fuses to prevent Keyboard and [USB](#) port from over-current or shortage. These fuses are soldered onboard that when it is broken (function to protect motherboard), user cannot replace them and result in malfunction of motherboard.

With expensive Resettable Fuse, the motherboard can be resumed back to normal function even after the fuse had done its protection job.

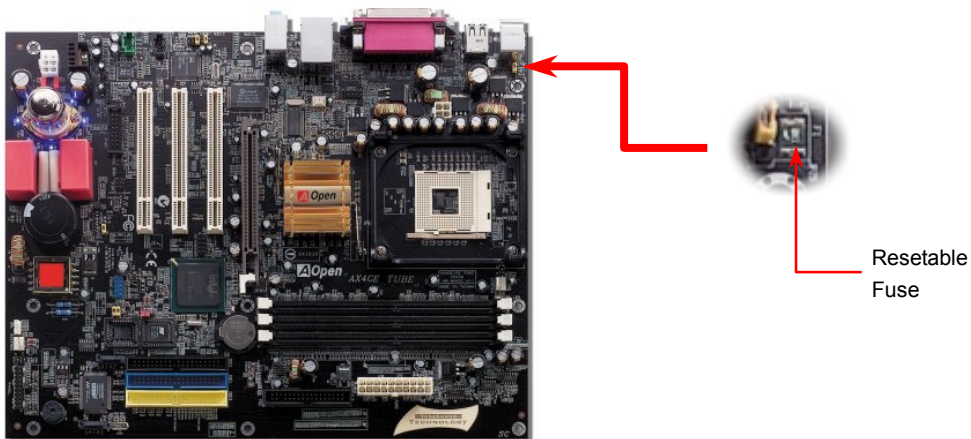

Low ESR Capacitor

The quality of low ESR capacitor (Low Equivalent Series Resistance) during high frequency operation is very important for the stability of CPU power. The idea of where to put these capacitors is another know-how that requires experience and detail calculation.

Not only that, AX4GE Tube / AX4PE Tube implements 2200 μF capacitors, which is much larger than normal capacitor (1000 & 1500 μF) and it provides better stability for CPU power.

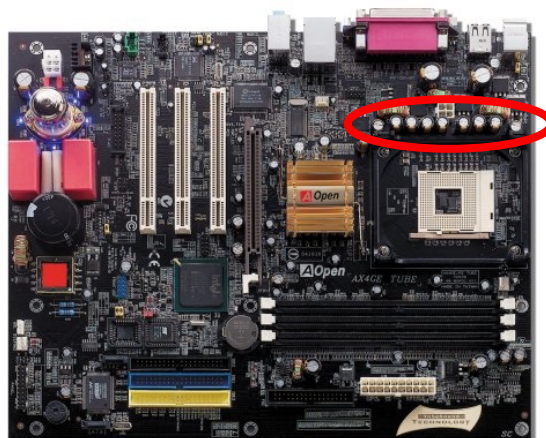

The power circuit of the CPU core voltage must be checked to ensure system stability for high speed CPUs (such as the new Pentium III, or when overclocking). A typical CPU core voltage is 2.0V, so a good design should control voltage between 1.860V and 2.140V. That is, the transient must be below 280mV. Below is a timing diagram captured by a Digital Storage Scope, it shows the voltage transient is only 143mv even when maximum 60A current is applied.

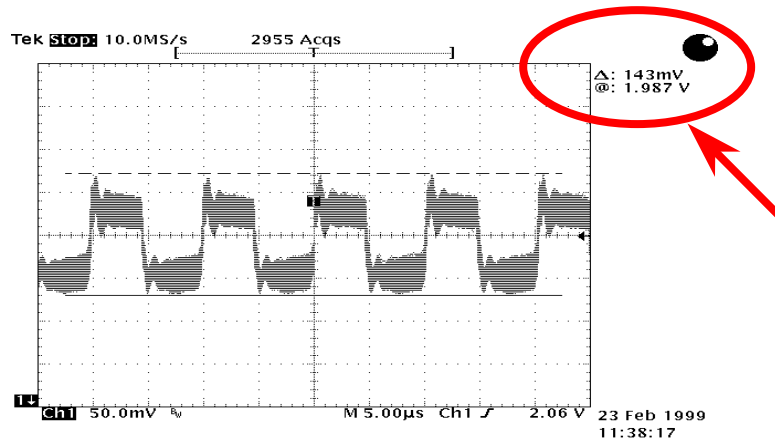

Note: This diagram for example only, it may not be exactly the same as the motherboard you purchased.

Layout (Frequency Isolation Wall)

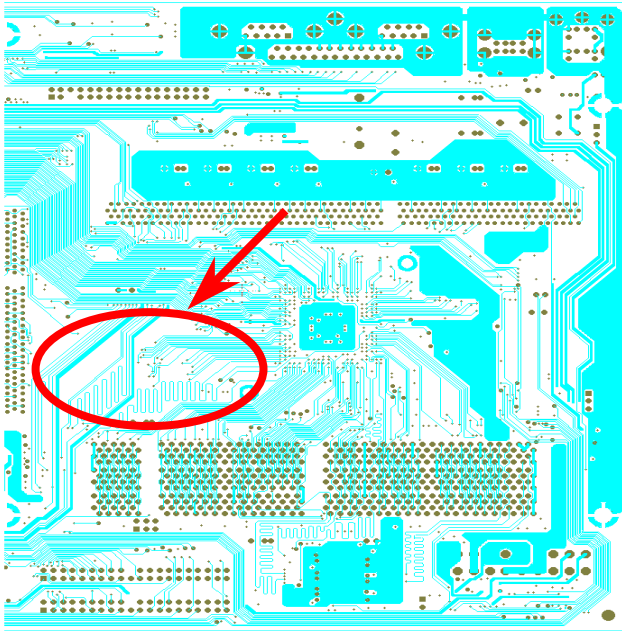

For high frequency operation, especially when overclocking, layout is the most important factor to make sure both chipset and CPU are working in stable condition. The layout of this motherboard implements AOpen's unique design called "Frequency Isolation Wall". Separating each critical portion of motherboard into regions, where each region operates in a same or similar frequency range, we can avoid cross talk and frequency interference between each region's operations and condition. The trace length and route must be calculated carefully. For example, the clock trace must be equal to length (not necessarily as short as possible) so that clock skew will be controlled within few a pico second ($1/10^{12}$ Sec)

Note: This diagram for example only, it may not look exactly the same as the motherboard you purchased.

Enlarged Aluminum Heatsink

Cool down CPU and Chipset are important for system reliability. Enlarged aluminum heat sink provides better heat consumption especially when you are trying to over-clock the CPU.

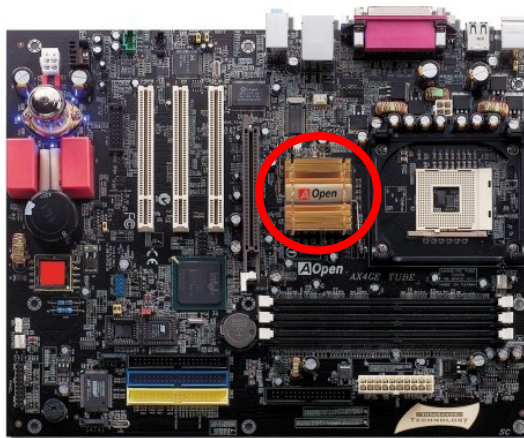

Vivid BIOS technology



Have you been fed up with the conservative and immutable POST screen? Let's rule out the tradition idea that POST screen are stiff and frigid, and let AOpen show you the newly developed VividBIOS to experience the lively vivid colourful POST screen!

Unlike earlier graphic POST screen which could occupy the whole screen and mask text information during POST, AOpen VividBIOS deals with graphics and texts separately, and makes them running simultaneously during POST. With this innovative design, VividBios now brings you a beautiful and sleek 256 colours screen without missing any important information shown on POST screen.

In addition, the limited space of BIOS ROM is another big issue. When all of the traditional BIOS can only show space-consuming and uncompressed Bitmap, AOpen has considerably tuned the BIOS to next generation, to recognize the smaller-sized GIF format and even dynamic-showing GIF animation.



Vivid BIOS shares the same fundamental technology with Open JukeBox CD Player, you may use the same EzSkin utility to change your

Vivid BIOS screen or to download your favourite Open JukeBox skin. If you see this little  shown beside your model name on the BIOS download page, <http://english.aopen.com.tw/tech/download/skin>, it is assured that your motherboard supports this innovative feature!



Open JukeBox Player



Here we are pleased to provide you a brand-new powerful interface—Open JukeBox. Without any cost you can have your PC turn into a fashionable CD player! This latest Open JukeBox motherboard aims at helping you directly operate your CD player on the PC without any hassle of entering Windows operation system.

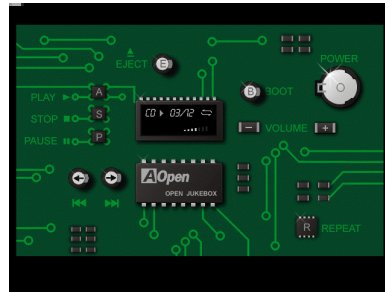
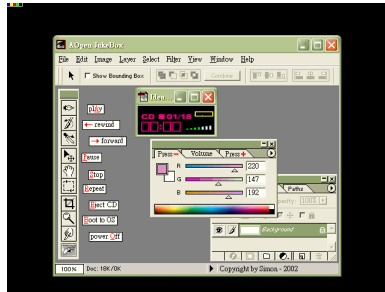
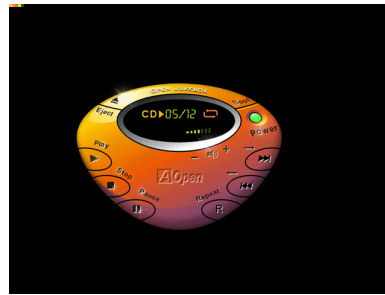

How Your Open JukeBox Works

The operation of Open JukeBox Player is the same as other CD players. By pressing specific keys on the keyboard you will find playing Open JukeBox Player couldn't be easier than the traditional CD Players. Below is the function description of respective buttons.



Power: Pressing **O**, to directly power off your computer with no hassle of entering Windows Operation System.

Boot: Pressing **B**, to intelligently boot to Windows Operation System for you.

Play: Pressing **A**, to start playing CD music.

Stop: Pressing **S**, to stop the music playing.

Pause: Pressing **P**, to pause the music playing temporarily.

Eject: Pressing **E**, to eject CD tray for you to change CD disc.

Repeat: Like other CD Players, pressing **R**, to shift the repeat mode.

Volume +/-: Pressing **+** or **-** to adjust the volume of playing music.

Rewind/Forward **← / →**: Pressing **arrow keys**, to rewind or forward the music.

Note: Though some latest Windows versions support "Digital Audio" through IDE bus. However, in order to use Open Jukebox player, which is driven under BIOS, it is a **MUST** to insert audio cable to CD-IN connector on the motherboard.

Your Open JukeBox Settings in BIOS

There are three Open JukeBox settings in BIOS as follows.

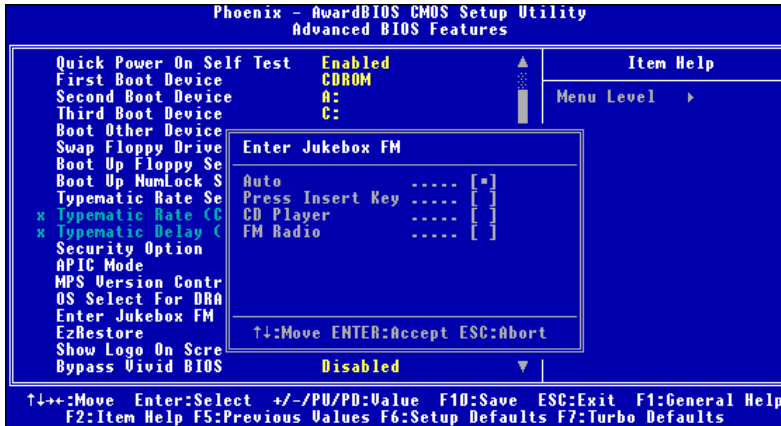

Auto: The default setting is “Auto” with which the Open JukeBox will automatically check the CD player every time you power on. The Open JukeBox will automatically be launched when it detects a music CD in your CD player.

Press Insert Key: Choosing this setting will allow a reminder message popped up on the screen during BIOS POST. It reminds you of pressing “Ins” key on your keyboard to start Open JukeBox Player; otherwise the system will launch the Windows Operation System.

CD Player: Choosing this setting allows the system to launch Open JukeBox Player every time you power on. However, by pressing **B** on your keyboard the Windows Operation System will be launched.

Your Open JukeBox EzSkin



Except these powerful functions above, Open JukeBox Player is also equipped with another fancy feature for you to change its "skin". You can download as many skins as you want from AOpen Website, and changing them whenever you want by using this useful utility – **EzSkin** – which may also be downloaded from our website.

Even more, you may design your own skins with innovative idea and sharing them to users around the world by uploading to our website. For further technical information, we welcome you to visit our website at <http://english.aopen.com.tw/tech/download/skin>.



Hyper Threading Technology



What is Hyper-Threading?

Hyper-Threading technology is an innovative design from Intel that enables multi-threaded software applications to process threads in parallel within each processor resulting in increased utilization of processor execution resources. As a result, an average improvement of ~40% in CPU resource utilization yields higher processing throughput.

How Hyper-Threading Works

A form of simultaneous multi-threading technology (SMT), Hyper-Threading technology allows multiple threads of software applications to be run simultaneously on one processor by duplicating the architectural state on each processor while the same processor execution resources is shared.

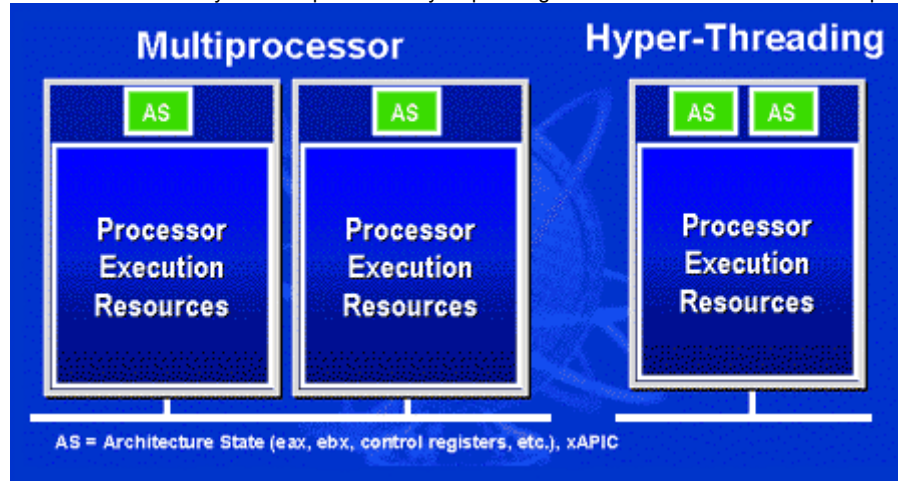

The figure below represents how a Hyper-Threading based processor differentiates a traditional multiprocessor. The left-hand configuration shows a traditional multiprocessor system with two physical processors. Each processor has its own independent execution resources and architectural state. The right-hand configuration represents an Intel Hyper-Threading technology based processor. You can see that the architectural state for each processor is duplicated, while the execution resources is shared.



For multiprocessor-capable software applications, the Hyper-Threading based processor is considered two separate logical processors on which the software applications can run without modification. Also, each logical processor responds to interrupts independently. The first logical processor can track one software thread, while the second logical processor tracks another software thread simultaneously. Because the two threads share the same execution resources, the second thread can use resources that would be otherwise idle if only one thread was executing. This results in an increased utilization of the execution resources within each physical processor.

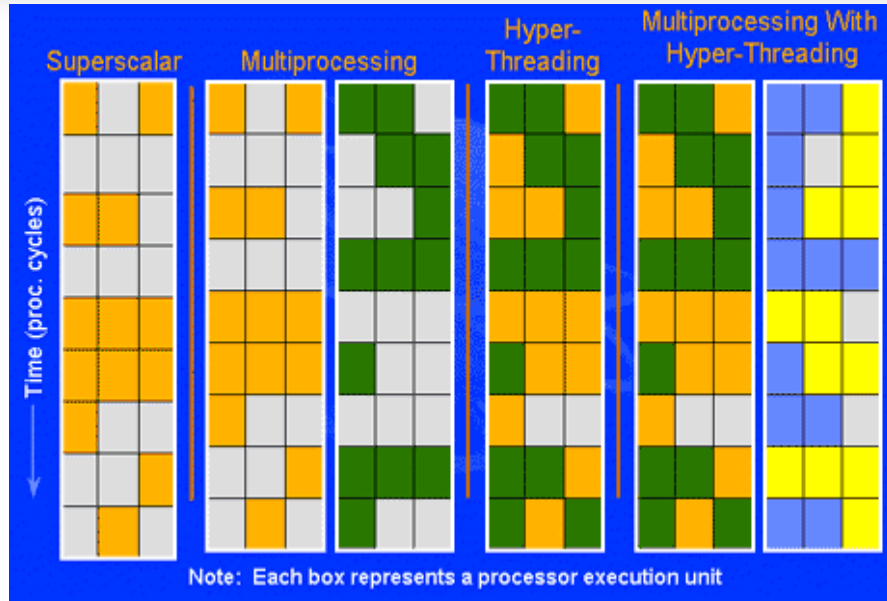

The figure below represents how Hyper-Threading saves time when it works. With two logical processors available on every single physical processor, multi-threaded applications can now take advantage of thread-level parallelism on each physical processor for additional performance. As software applications continue to be optimized to take greater advantage of processor parallelism, Hyper-Threading technology provides an additional boost for newer capabilities and the growing needs of today's users.

Driver and Utility

There are motherboard drivers and utilities in [AOpen Bonus CD](#). You don't need to install all of them to boot your system. But after you finish the hardware installation, you have to install your operation system first (such as Windows 2000) before you install any drivers or utilities. Please refer to your operation system's installation guide.

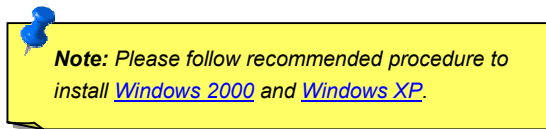

Note: Please follow recommended procedure to install [Windows 2000](#) and [Windows XP](#).

Auto-run Menu from Bonus CD

You can use the auto-run menu of Bonus CD. Choose the utility and driver and select model name.

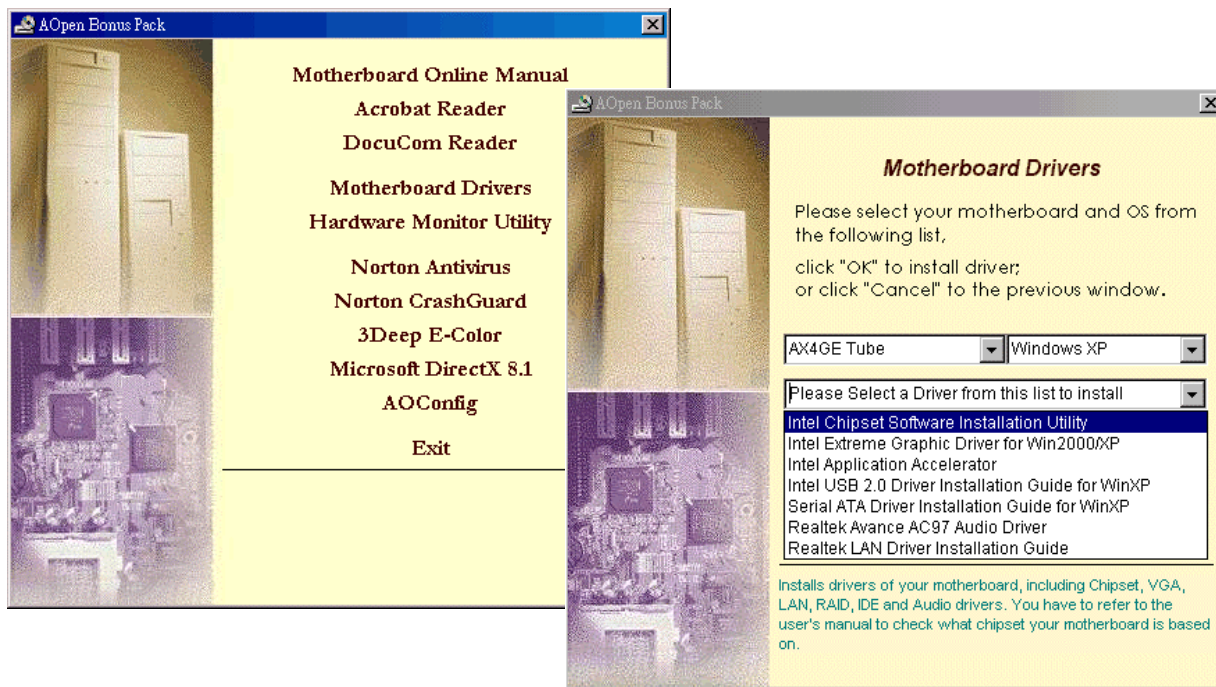

Installing Intel® Chipset Software Installation Utility

Some Windows systems cannot recognize newer chipsets that release later than those systems, therefore “?” marks may appear on “Device manager” page. Intel 845GE/PE cannot support systems earlier than Windows 95 and 98 first version. As for other later Windows systems, you can install Intel INF Update Utility from Bonus Pack CD auto-run menu to eliminate the “?” marks.

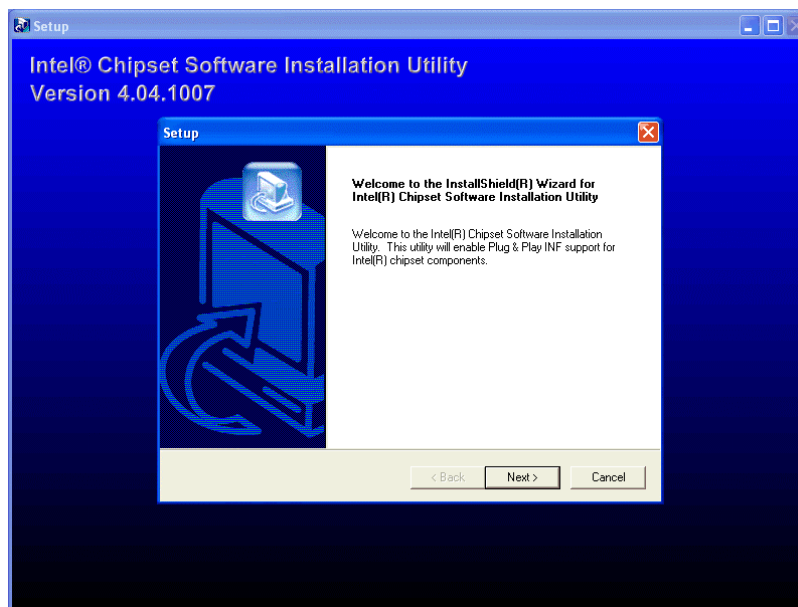

Installing Intel IAA Driver

You can install Intel IAA Driver to increase the performance of software applications and reduce PC boot times. You can find it in AOpen Bonus Pack CD.

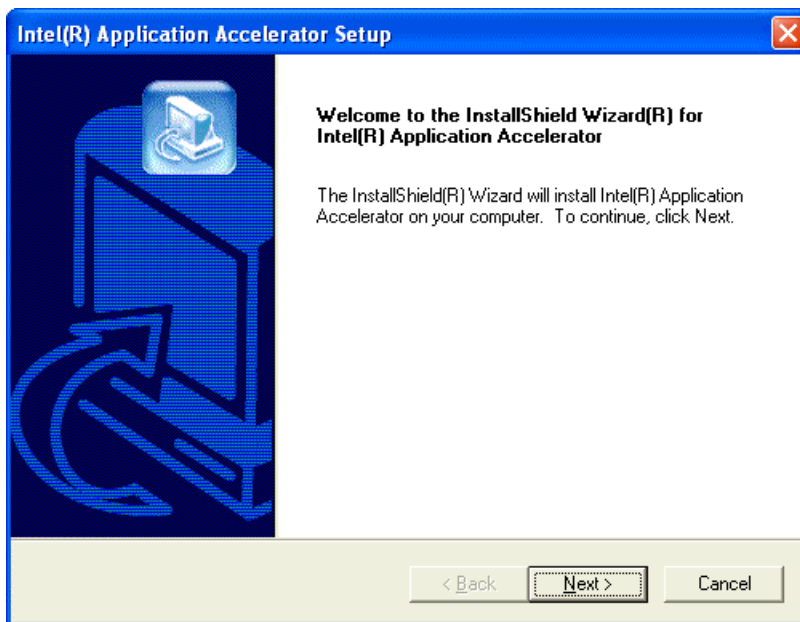

Installing Intel Extreme Graphic Driver (For AX4GE Tube)

You can download Intel Extreme graphic driver from the Bonus Pack CD.

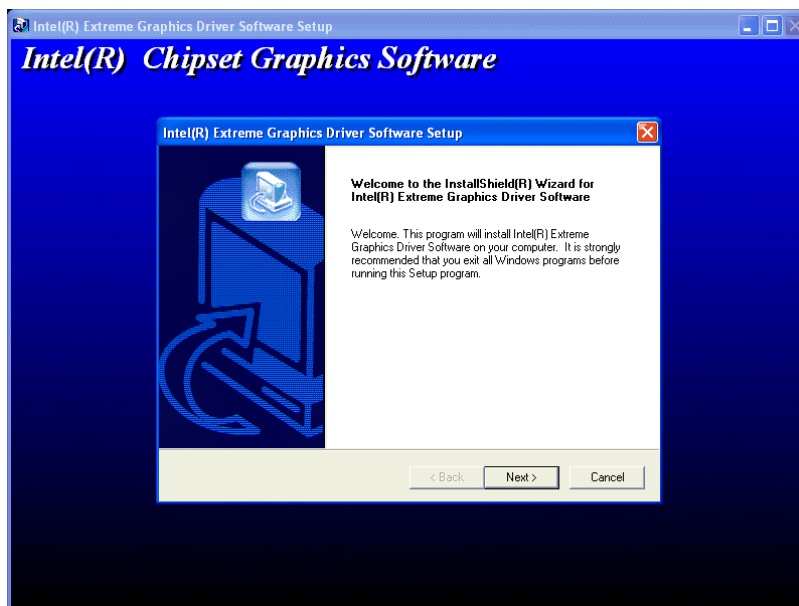

Installing Promise SATA Driver

Installing Driver During New Windows XP Installation

1. Start the installation:
 - a. Floppy Install: Boot the computer with the Windows XP installation diskettes.
 - b. Floppyless Install: Boot from floppy and type "WINNT". After files have been copied, the system will reboot. On the reboot, press <F6> after the message "Setup is inspecting your computer's hardware configuration..." appears.
 - c. CD-ROM Install: Boot from the CD-ROM. Press <F6> after the message "Press F6 if you need to install third party SCSI or RAID driver" appears.
2. When the "Windows XP Setup" window is generated, press "S" to Specify an Additional Device(s)
3. Insert the Promise SATA150 driver diskette into drive A: and press "Enter" key.
4. Use "↑" or "↓" to choose "WinXP Promise SATA TX2plus (tm) IDE Controller" from the list that appears on screen, and then press the "Enter" key.
5. Press "S" to use the driver on the floppy disk, and then press "enter" to continue with installation. If you press "enter" to use "Windows default driver", you will encounter the following error message in the next phase of the installation: "Setup did not find any hard disk drives installed in your computer"

NOTE: Restart installation and then use option "S" to load driver from floppy disk.

6. The Windows XP Setup screen will appear again saying, "Setup will load support for the following mass storage devices:" The list will include "WinXP Promise SATA TX2plus (tm) IDE Controller".

NOTE: If you need to specify any additional devices to be installed, do so at this time. Once all devices are specified, continue to the next step -

7. From the Windows XP Setup screen, press the Enter key. Setup will now load all device files and then continue the Windows XP installation.

Installing Driver in Existing Windows XP System

WARNING: If you will be moving the boot drive containing the existing Windows XP operating system to the SATA150 connector, the SATA150 driver **MUST** be loaded on to this hard drive while it is still attached to your existing hard drive controller. Do not attach this drive or any other hard drive to the SATA150 controller before completing this step.

After enabling the SATA150, Windows XP setup will show a "Found New Hardware" dialog box. Under Windows XP, "Mass Storage Controller" will be displayed.

1. Click on "Next," and from the generated list box, choose "Install from a list or special location (Advanced)"
2. Click on "Next," and from the generated choices, choose "Include this location in the search:"
3. Insert the Promise SATA150 driver diskette into drive A:.
4. Type "A:\" in the text box that appears. Press " OK " .
 - 3a. Insert the Bonus CD in CD-ROM.
 - 4a. Type "[CD-ROM]:\Driver\Promise\SATA150\Driver\WinXP" in the text box that appears. Press " OK " .
5. Click on "Next." A message informing you that Windows XP has found "WinXP Promise SATA TX2plus (tm) IDE Controller" should appear.

When the New Hardware Wizard has finished installing the Promise SATA150 software, click on "Finish"

Confirming Windows XP Installation

1. From Windows XP, open the Control Panel from "My Computer".
2. Click on "Performance and maintenance".
3. Click on the "System" icon.
4. Choose the "Hardware" tab, and then click the "Device Manager" tab.
5. Click the "+" in front of "SCSI controllers". "WinXP Promise SATA TX2plus (tm) IDE Controller" should appear.

Windows 2000 Installation Guide

Installing Driver During New Windows 2000 Installation

1. Start the installation:
 - a. Floppy Install: Boot the computer with the Windows 2000 installation diskettes.
 - b. Floppyless Install: Boot from floppy and type "WINNT". After files have been copied, the system will reboot. On the reboot, press <F6> after the message "Setup is inspecting your computer's hardware configuration..." appears.
 - c. CD-ROM Install: Boot from the CD-ROM. Press <F6> after the message "Press F6 if you need to install third party SCSI or RAID driver" appears.
2. When the "Windows 2000 Setup" window is generated, press "S" to Specify an Additional Device(s)



3. Insert the Promise SATA150 driver diskette into drive A: and press "Enter" key.
4. Use "↑" or "↓" to choose "Win2000 Promise SATA TX2plus (tm) IDE Controller" from the list that appears on screen, and then press the "Enter" key.
5. The Windows 2000 Setup screen will appear again saying "Setup will load support for the following mass storage devices:" The list will include "Win2000 Promise SATA TX2plus (tm) IDE Controller".

NOTE: If you need to specify any additional devices to be installed, do so at this time. Once all devices are specified, continue to the next step -

6. From the Windows 2000 Setup screen, press the Enter key. Setup will now load all device files and then continue the Windows 2000 installation.

Installing Driver in Existing Windows 2000 System

WARNING: If you will be moving the boot drive containing the existing Windows 2000 operating system to the SATA150 connector, the SATA150 driver **MUST** be loaded on to this hard drive while it is still attached to your existing hard drive controller. Do not attach this drive or any other hard drive to the SATA150 connector before completing this step.

After enabling the SATA150 IDE controller and rebooting your system, Windows 2000 setup will show a "New Hardware Found" dialog box. Under Windows 2000, "PCI Mass Storage Controller" will be displayed.

1. Choose "Search for a suitable driver for my device (Recommended)". from the list, and then press "Enter".
2. Choose "Specify a location." and then press "Next"
3. Choose "Mass Storage controller" and press "next" and next screen press "finish"



4. Insert the Promise SATA150 driver diskette into drive A:.
5. Type "A:\." in the text box that appears. Press " OK ".
 - 4a. Insert the Bonus CD in CD-ROM.
 - 5a. Type "[CD-ROM]:\Driver\Promise\SATA150\Driver\Win2000" in the text box that appears. Press " OK ".
6. Click on "Next." A message informing you that Windows has found "Win2000 Promise SATA TX2plus (tm) IDE Controller" should appear.
7. Click on "Next," and then on "Finish."

Confirming Windows 2000 Installation

1. From Windows 2000, open the Control Panel from "My Computer" followed by the System icon.
2. Choose the "Hardware" tab, and then click the "Device Manager" tab.
3. Click the "+" in front of "SCSI controllers". "Win2000 Promise SATA TX2plus (tm) IDE Controller" should appear.

Windows NT 4.x Installation Guide

Installing Drivers During New Windows NT 4.0 Installation

1. Start the system installation by booting from the Windows NT disk:



- a. Floppy install: boot the system with the Windows NT installation diskettes.
 - b. Floppyless install: boot from floppy and type "WINNT /B". After files have been copied, the system will reboot. On the reboot, press the "F6" key when the message "Setup is inspecting your computer's hardware configuration..." appears.
 - c. c. CD-ROM disk install: boot from the CD-ROM disk and press the "F6" key when the message "Setup is inspecting your computer's hardware configuration..." appears.
2. When the "Windows NT Setup" window is generated, press "S" to specify an Additional Device(s).
 3. Use "↑" or "↓" to select "Other" and press the "Enter" key.
 4. Insert the driver diskette into drive A: and press the "Enter" key.
 5. Choose "WinNT Promise SATA TX2plus (tm) IDE Controller" from the list that appears on screen, and then press the "Enter" key.
 6. The Windows NT Setup screen will appear again saying, "Setup will load support for the following mass storage devices:" The list will include "WinNT Promise SATA TX2plus (tm) IDE Controller".
- NOTE: If you need to specify any additional devices to be installed, do so at this time. Once all devices are specified, continue to the next step -
7. From the Windows NT Setup screen, press the Enter key. Setup will now load all device files and then continue the Windows NT installation.

After a successful installation, the "SCSI Adapter Setup" box will show that the "WinNT Promise SATA TX2plus (tm) IDE Controller" driver has been installed.

Installing Drivers with Existing Windows NT 4.0



WARNING: If you wish to use your current bootable drive with the Windows NT4 operating system on the SATA150, perform the steps below while the boot drive is still attached to your existing onboard IDE controller. Do not attach any drives to your SATA150 until the steps below are complete.

1. Choose "Settings" from the "Start" menu.
2. Choose "Control Panel" from the "Settings" menu.
3. Double-click on the "SCSI Adapters" icon, which generates the "SCSI Adapters" dialog box.
4. Choose "Drivers," and then press "Add."
5. In the "Install Drivers" dialog box, press "Have Disk..."
6. When the "Install From Disk" appears, Insert the driver diskette into drive A:, then choose "OK."
7. When the "Install Driver" dialog box appears, select "WinNT Promise SATA TX2plus (tm) IDE Controller" and then press "OK."
8. When the "Select SCSI Adapter Option" dialog box appears, press "Install."
9. After a successful installation, the "SCSI Adapter Setup" box will show that the "WinNT Promise SATA TX2plus (tm) IDE Controller" driver has been installed.
10. Power off your system, and then attach your hard drive(s) to the SATA150 controller.

Installing Drivers During Windows Me Installation

The following details the installation of the Serial ATA drivers while installing Windows Me (with the Serial ATA controller is enabled already).



1. Install Windows Me fully.
2. After installation, go the "Start" menu and choose "Settings."
3. From the "Settings" menu, choose "Control Panel."
4. In the "Control Panel" window, double-click on the "System" icon.
5. In the "System" window, choose the "Device Manager" tab.
6. In the hierarchical display under "Other Devices" is a listing for "PCI Mass Storage Controller." Choose it and then press the "Properties" button.
7. Choose "Reinstall Driver," and then press "Next."
8. Choose "Specify the location of the driver (Advanced)," then press "Next".
9. Insert the Promise SATA150 driver diskette into drive A:.
10. Choose "Specify a Location," and then type "A:\"
 - 9a. Insert the "Bonus CD" in CD-ROM.
 - 10a. Choose "Specify a Location," and then type "[CD-ROM]:\Driver\Promise\SATA150\DriverWin98-Me" in the text box.
11. Press the "Next" button. A message informing you that Windows Me has found "Win98-ME Promise SATA150 TX2plus(tm) IDE Controller" should appear.
12. Press "Next," then "Finish".

Confirming Driver Installation in Windows Me



To confirm that the driver has been properly loaded in Windows Me, perform the following steps:

1. Choose "Settings" from the "Start" menu.
2. Choose "Control Panel," and then double-click on the "System" icon.
3. Choose the "Device Manager" tab, and then click the "+" in front of "SCSI & RAID controllers". "Win98-ME Promise SATT150 TX2plus(tm) IDE Controller" should appear.

Installing Drivers During Windows 98 SE Installation

The following details the installation of the Serial ATA drivers while installing Windows 98 SE (with the SATA controller is enabled already).

1. After enabling the Serial ATA controller and configuring the hard drive(s), partition and format your hard drive(s), if necessary.
2. Install Windows 98 SE normally.
3. After installation, go the "Start" menu and choose "Settings."
4. From the "Settings" menu, choose "Control Panel."
5. In the "Control Panel" window, double-click on the "System" icon.
6. In the "System" window, choose the "Device Manager" tab.
7. In the hierarchical display under "Other Devices" is a listing for "PCI Mass Storage Controller." Choose it and then press the "Properties" button.
8. Choose "Reinstall Driver," and then press "Next."
9. Choose "Search for a better driver than the one your device is using now (recommended)," then press "Next."

10. Insert the Promise SATA150 driver diskette into drive A:.
11. Choose "Specify a Location," and then type "A:\"
 - 10a. Insert the "Bonus CD" in CD-ROM.
 - 11a. Choose "Specify a Location," and then type "[CD-ROM]:\Driver\Promise\SATA150\Driver\Win98-Me" in the text box.
12. Press the "Next" button. A message informing you that Windows has found "Win98-ME Promise SATA150 TX2plus(tm) IDE Controller" should appear.
13. Press "Next," then "Finish".

Confirming Driver Installation in Windows 98

To confirm that the driver has been properly loaded in Windows 98, perform the following steps:

1. Choose "Settings" from the "Start" menu.
2. Choose "Control Panel," and then double-click on the "System" icon.
3. Choose the "Device Manager" tab, and then click the "+" in front of "SCSI controllers." "Win98-ME Promise SATA150 TX2plus(tm) IDE Controller" should appear.

Installing LAN Driver

You can download LAN Driver from the Bonus Pack CD.

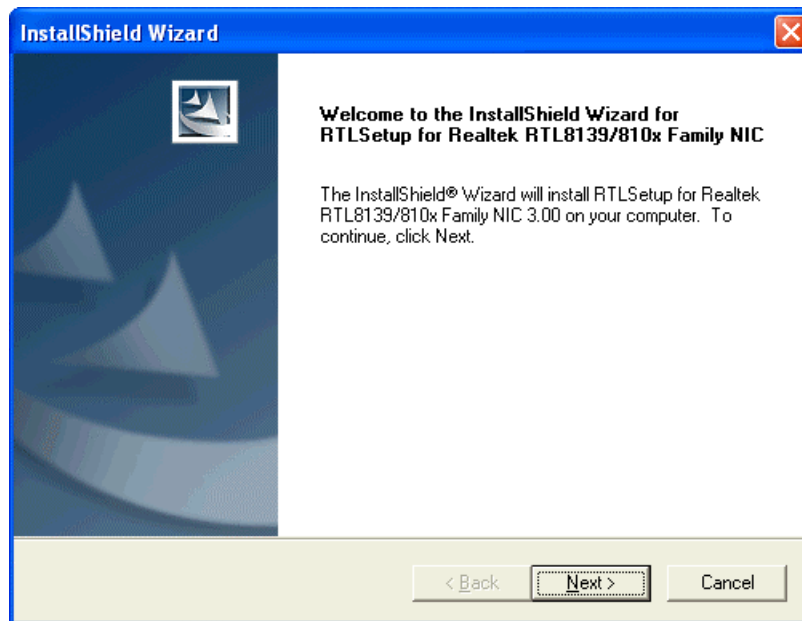

Installing Onboard Audio Driver

This motherboard comes with [AC97 CODEC](#). This audio driver supports Windows 98SE and upper Windows OS; you can find the audio driver from the Bonus Pack CD auto-run menu.

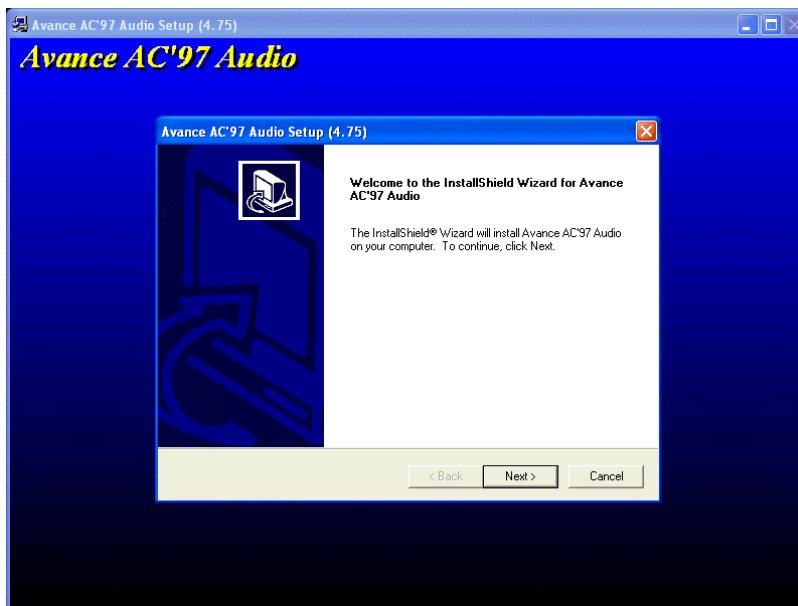

Installing USB2.0 Driver

Installing Driver in Existing Windows XP System

After enabling the USB 2.0, Windows XP setup will show a "Found New Hardware" dialog box. Under Windows XP, "Universal Serial Bus (USB) Controller" will be displayed.

1. Click on "Next," and from the generated list box, choose "Install from a list or special location (Advanced)", click "Next"
2. Click on "Next," and from the generated choices, choose "Include this location in the search:"
3. Insert the Bonus CD in CD-ROM.
4. Type "[CD-ROM]:\Driver\Intel\USB2.0\WinXP" in the text box that appears.
5. Click on "Next." A message informing you that Windows XP has found "Intel PCI to USB Enhanced Host Controller A1" should appear.
6. When the New Hardware Wizard has finished installing the USB driver, click on "Finish"

Confirming Windows XP Installation

1. Tools/Folder Options.../View. Change below item:
2. Enable "Display the full path in the title bar".
3. Enable "Show Hidden files and folders".
4. Disable "Hide extensions of known file types".
5. Disable "Hide protected operating system files (Recommended)".
6. Check USB driver version from My Computer, Local Disk C:, Show the content of this drive, Windows directory, Show the content of this

drive, System32 directory, Show the content of this drive, Drivers directory, Show the content of this drive, View, Details.

1. USBEHCI.SYS - 3/20/2002.
2. USBPORT.SYS - 8/17/2001.
3. USBHUB.SYS - 8/17/2001.

So, new 3616 driver does not install complete.

[Install by manual]

1. Disable Windows File Protection (WFP)
 1. Start button/run/Regedit.
 2. Set HKEY_LOCAL_MACHINE\Software\Microsoft\Windows NT\CurrentVersion\Winlogon\SFCDisable = 1
2. Copy all USB files from CD to HDD.
 1. Copy all test drivers to %windir%\driver cache\i386.
 2. Copy all test drivers to %windir%\system32\ddlcache
You need to copy file to this directory first. Otherwise, Windows XP will replace file from this directory to system32\drivers.
 3. Copy all test drivers to %windir%\system32\drivers.
3. Check USB driver version again.
 1. USBEHCI.SYS - 3/20/2002.
 2. USBPORT.SYS - 3/20/2001.
 3. USBHUB.SYS - 3/20/2001.

Test USB20 HDD with restart for 10 times. The USB 20 HDD can detection with any problem for all 10 times.

Installing Driver in Existing Windows 2000 System

After enabling the USB 2.0 controller and rebooting your system, Windows 2000 setup will show a "New Hardware Found" dialog box. Under Windows 2000, "Universal Serial Bus (USB) Controller" will be displayed.

1. Choose "Search for a suitable driver for my device (Recommended)". from the list, and then press "Enter".
2. Choose "Specify a location." and then press "Next"
3. Insert the Bonus CD in CD-ROM.
4. Type "[CD-ROM]:\Driver\Intel\USB2.0\Win2000" in the text box that appears. Press " OK ".
5. Click on "Next." A message informing you that Windows has found "Intel PCI to USB Enhanced Host Controller A1" should appear.
6. Click on "Next," and then on "Finish."

Confirming Windows 2000 Installation

1. From Windows 2000, open the Control Panel from "My Computer" followed by the System icon.
2. Choose the "Hardware" tab, and then click the "Device Manager" tab.
3. Click the "+" in front of "Universal Serial Bus controllers". "Intel PCI to USB Enhanced Host Controller A1" should appear.

AOConfig Utility

AOOpen always dedicated to provide users a much friendly computer environment. We now bring you a comprehensive system detection utility. AOConfig is a Windows based utility with user-friendly interface that allows users to obtain information of the operation system and hardware such as motherboard, CPU, memory, PCI devices and IDE devices. The powerful utility also displays the version of BIOS and firmware for your convenience of maintenance.

Moreover, AOConfig allows users to save information in *.BMP or *.TXT format which users may collect the system information in detail and send them to AOOpen directly for technical support or for further diagnose of system problems.

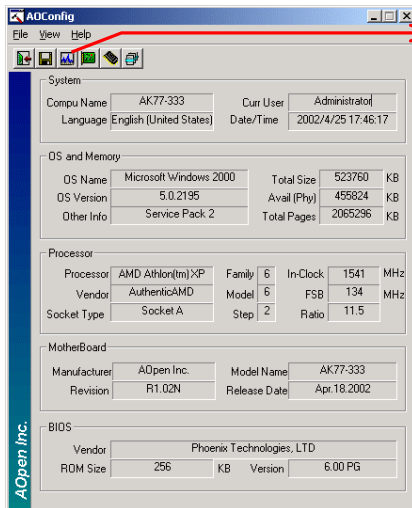

1. The system page shows the detailed information of the motherboard, operating system, processor, and BIOS version.

2. The PCI device page shows the configurations of all PCI devices installed in your motherboard.

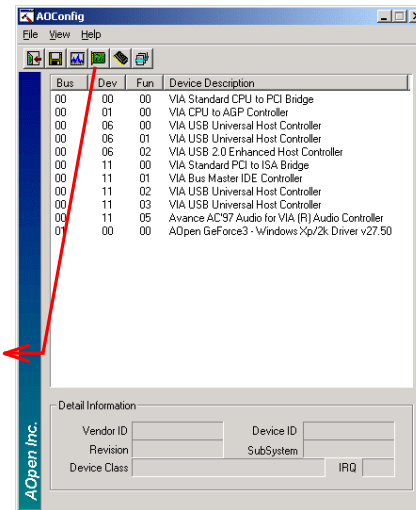

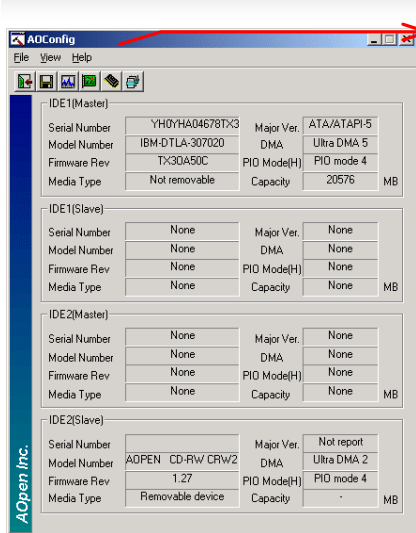

3. This page presents the IDE device information, such as serial number, manufacturer, firmware version, and capacity.

4. From this page, users can obtain the technical support information of AOpen. Moreover, detailed information could be saved in .bmp or .txt format.

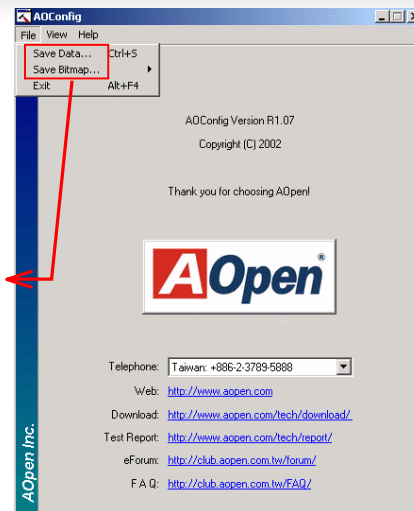

NOTE:

AOpenConfig can be used under Windows 98SE/ME, NT4.0/2000, or even the latest Windows XP. Please also note that AOpenConfig can only be operated in a system equipped with an AOpen motherboard. Before running AOpenConfig, all applications must be closed.

Installing Hardware Monitoring Utility

You can install Hardware Monitoring Utility to monitor CPU temperature, fans and system voltage. The hardware monitoring function is automatically implemented by BIOS and utility software. No hardware installation is needed.

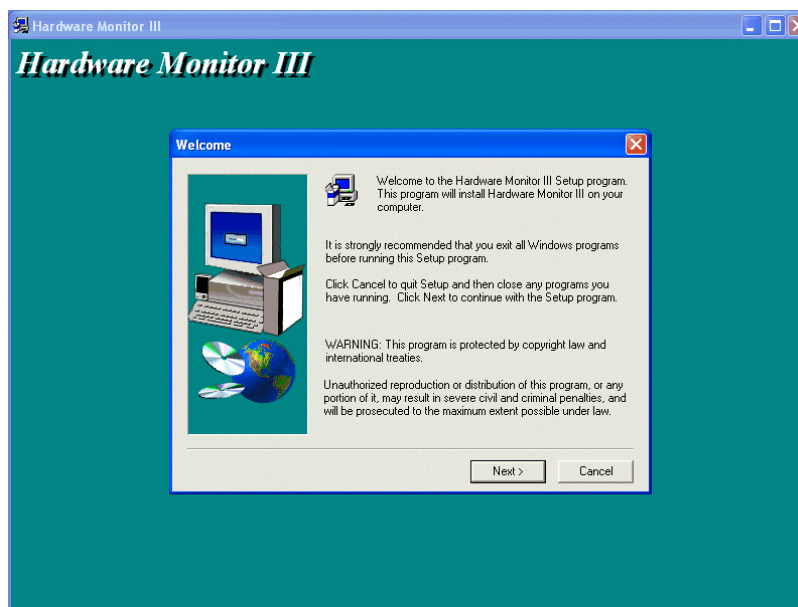

Phoenix-AWARD BIOS

System parameters can be modified by going into [BIOS](#) Setup menu, this menu allows you to configure the system parameters and save the configuration into the 128 bytes CMOS area, (normally in the RTC chip or in the main chipset).

Phoenix-Award BIOS™ installed in the [Flash ROM](#) of the motherboard is a custom version of an industry standard BIOS. The BIOS provides critical low-level support for standard devices such as hard disk drives, serial and parallel ports.

Most BIOS settings of AX4GE Tube / AX4PE Tube have been optimized by AOpen's R&D engineering team. But, the default setting of BIOS still can't fine-tune the chipset controlling entire system. Therefore, the rest of this chapter intends to guide you the process of configuring your system setup.

[To enter to BIOS setup menu](#), press when [POST \(Power-On Self Test\)](#) screen is shown on your monitor.

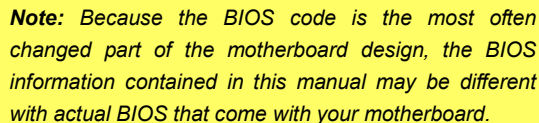

Note: *Because the BIOS code is the most often changed part of the motherboard design, the BIOS information contained in this manual may be different with actual BIOS that come with your motherboard.*

About BIOS Function Description...

AOpen always dedicates to give user a more friendly computer system. Now, we include all function descriptions of BIOS setup program into the BIOS Flash ROM. When you select one function of BIOS setup program, the function description will appear at the right side of screen. Therefore, you don't need to read this manual while you change BIOS settings.

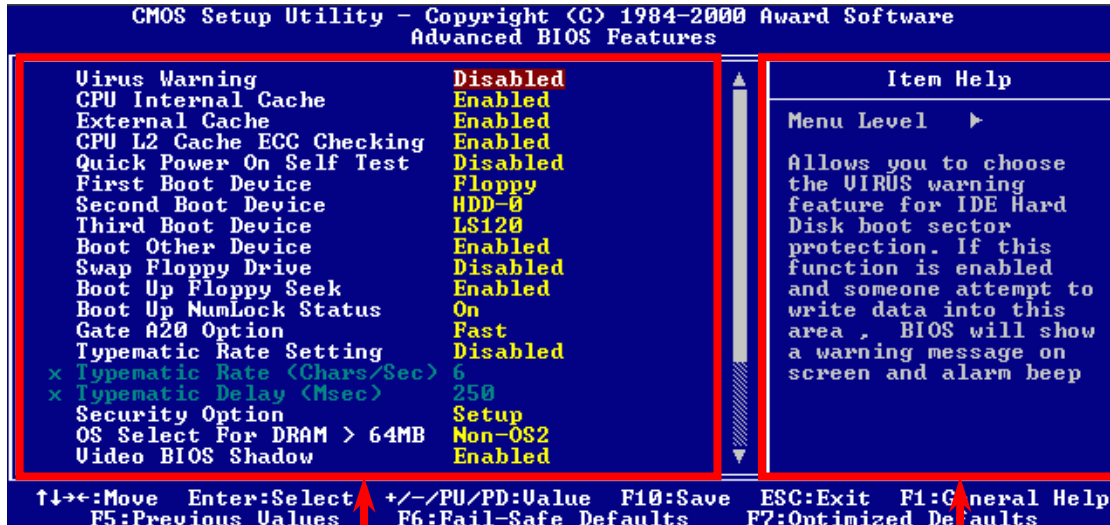

Menu Items Select Window

Item Function Description Window

How To Use Phoenix-Award™ BIOS Setup Program

Generally, you can use arrow keys to highlight items that you want to choose, then press <Enter> key to select, and use the <Page Up> and <Page Down> key to change setting values. You can also press <F1> key for help and press <Esc> key to quit Phoenix-Award™ BIOS setup program. The following table provides details about how to use keyboard in the Phoenix-Award™ BIOS setup program. By the way, all products of AOpen also provide a special function in BIOS setup; you can press <F3> key selecting you preferred menu language.

Key	Description
Page Up or +	Changing setting to next value or increase the value.
Page Down or -	Changing setting to previous value or decrease value.
Enter	Select the item.
Esc	1. In main menu: Quit and don't save any change. 2. In sub menu: Exit current menu to main menu.
Up Arrow	Highlight previous item.
Down Arrow	Highlight next item.
Left Arrow	Move the light bar to left side of menu.
Right Arrow	Move the light bar to right side of menu.
F1	Get menu or item help description.
F3	Changing menu language.
F5	Load previous setting value from CMOS.

Key	Description
F6	Load fail-save setting value from CMOS.
F7	Load turbo setting value from CMOS.
F10	Save changed setting and exit setup program.

How To Enter BIOS Setup

After you finish jumper settings and connect correct cables, power on and enter the BIOS Setup. Press during POST (Power-On Self Test) and choose "Load Setup Defaults" for recommended optimal performance.

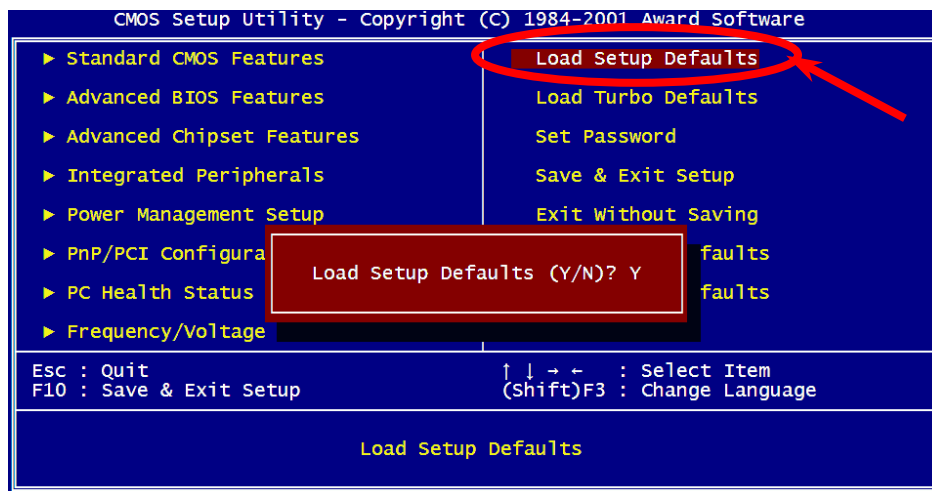

Warning: Please avoid of using "Load Turbo Defaults", unless you are sure your system components (CPU, DRAM, HDD, etc.) are good enough for turbo setting.



BIOS Upgrade under Windows environment



With outstanding R&D ability of AOpen, we now bring you a whole new BIOS Flash wizard ---- EzWinFlash. With an eye to users convenience, EzWinFlash combines the BIOS binary code and flash module together, so the only thing you have to do is just clicking on the utility you downloaded from web and let it helps you complete the flash process automatically. EzWinFlash detects your motherboard and checks the BIOS version cleverly to prevent your system from any possible failure. Moreover, EzWinFlash has been taken into consideration to go with any windows platform you might be using, no matter if you're using Windows 95/98, 98SE/ME, NT4.0/2000, or even the latest Windows XP.

In the meanwhile, in order to provide a much more user-friendly operating environment, AOpen EzWinFlash is natively designed to have multi-language function to provide easier way for users' usage in changing BIOS setting.

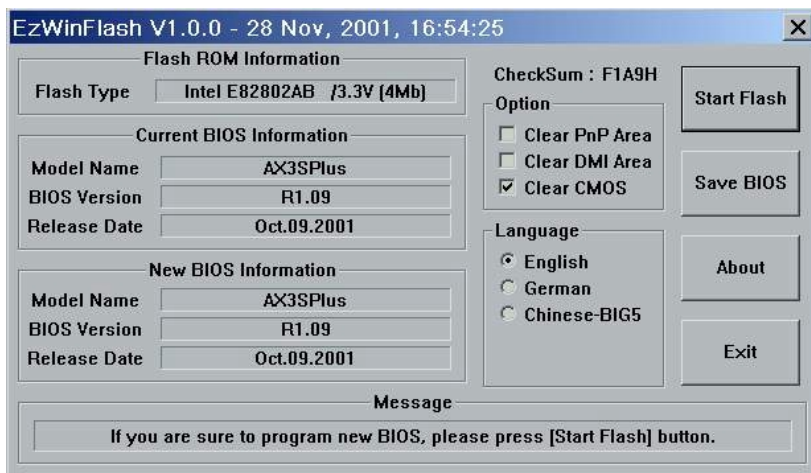

Caution: By updating your motherboard, you are taking a risk of BIOS flash failure. If your motherboard is working stable, and there are no major bugs that had been fixed by a latter BIOS revision, we recommend that you DO NOT try to upgrade your BIOS. If you intent on upgrading, PLEASE BE SURE to get the right BIOS revision for the right motherboard model to avoid any possibility failure.



You may accomplish BIOS upgrade procedure with EzWinFlash by the following steps, and it's STRONGLY RECOMMENDED to close all the applications before you start the upgrading.

1. Download the new version of BIOS package [zip](#) file from AOpen official web site. (ex: <http://www.aopen.com>)
2. Unzip the download BIOS package (ex: WAX4GET102.ZIP) with WinZip (<http://www.winzip.com>) in Windows environment.
3. Save the unzipped files into a folder, for example, WAX4GET102.EXE & WAX4GET102.BIN.
4. Double click on the WAX4GET102.EXE, EzWinFlash will detect the model name and BIOS version of your motherboard. If you had got the wrong BIOS, you will not be allowed to proceed with the flash steps.
5. You may select preferred language in the main menu, then click [Start Flash] to start the BIOS upgrade procedure.
6. EzWinFlash will complete all the process automatically, and a dialogue box will pop up to ask you to restart Windows. You may click [YES] to reboot Windows.
7. Press at POST to [enter BIOS setup](#), choose "Load Setup Defaults", then "Save & Exit Setup". Done!

It is strongly recommended NOT to turn off the power or run any application during FLASH PROCESS.



Warning: The new BIOS upgrade will permanently replace your original BIOS's settings when flashing. You may need to reconfigure your BIOS setting so that your system can go back to work as normal.

Overclocking

As a leading manufacturer in motherboard industry, AOpen always listens to what customers want and develop products to fit different user's requirements. Reliability, compatibility, leading technology and friendly features are our basic goals when designing motherboards. Other than above mentioned design criteria, there are power users who are always seeking to push the limitation of the system performance by overclocking which we call them "Overclocker".

This section is dedicated to overclockers.

This high performance motherboard is designed for maximum **400/533MHz** CPU bus clock. But it comes with clock generator of **992MHz (248MHz x4)** when we design it to accommodate with future CPU bus clock. Not only that, the CPU clock ratio can be up to 24x that supports almost all of Pentium® 4 CPUs in the future and provides flexibility for overclockers.

But not guaranty. 😊

***Tip:** Note that overclocking may also cause thermal problem. Please make sure that the cooling fan and the heatsink were adequate to dissipate excessive heat that's generated by overclocking the CPU.*

***Warning:** The design of this product follows CPU and chipset vendor's design guideline. Any attempts to push beyond product specification are not recommended and you are taking your own risk to damage your system or important data. Before doing overclocking, you must make sure your components are able to tolerate such abnormal setting, especially CPU, DRAMs, hard disks, and AGP VGA cards.*

VGA Card & Hard Disk

VGA and HDD is key components for overclocking, for your reference, the following list are what have been successful overclocked in our lab. Please note that AOpen can not guaranty they can be successful overclocked again. Please check the **Available Vendor List (AVL)** by link to our official website.

VGA: <http://www.aopen.com.tw/tech/report/overclk/mb/vga-oc.htm>

HDD: <http://www.aopen.com.tw/tech/report/overclk/mb/hdd-oc.htm>

Glossary

AC97

Basically, AC97 specification separates sound/modem circuit to two parts, digital processor and a [CODEC](#) for analogy I/O they are linked by AC97 link bus. Since digital processor can be put into motherboard main chipset, the cost of sound/modem onboard solution can be reduced.

ACPI (Advanced Configuration & Power Interface)

ACPI is the power management specification of PC97 (1997). It intends to save more power by taking full control of power management to operating system and bypass [BIOS](#). The chipset or super I/O chip needs to provide standard register interface to operating system (such as Windows 98). This is a bit similar as the [PnP](#) register interface. ACPI defines ATX momentary soft power switch to control the power state transition.

AGP (Accelerated Graphic Port)

AGP is a bus interface targeted for high-performance 3D graphic. AGP supports only memory read/write operation and single-master single-slave one-to-one only. AGP uses both rising and falling edge of the 66MHz clock, for 2X AGP, the data transfer rate is $66\text{MHz} \times 4\text{byte} \times 2 = 528\text{MB/s}$. AGP is now moving to 4X mode, $66\text{MHz} \times 4\text{byte} \times 4 = 1056\text{MB/s}$. AOpen is the first company to support 4X AGP motherboards by both AX6C (Intel 820) and MX64/AX64 (VIA 694x), started from Oct 1999.

AMR (Audio/Modem Riser)

The [CODEC](#) circuit of AC97 sound/modem solution can be put on motherboard or put on a riser card (AMR card) that connects to motherboard through AMR connector.

AOpen Bonus Pack CD

A disc bundled with AOpen motherboard product; there are motherboard drivers, Acrobat Reader for [PDF](#) online manual and other useful utilities.

APM (Advanced Power Management)

Unlike [ACPI](#), BIOS controls most APM power management functions. AOpen Suspend to Hard Drive is a good example of APM power management.

ATA (AT Attachment)

ATA is the specification of diskette interface. In 80's, many software and hardware manufacturers instituted the ATA specification together. The AT is meaning International Business Machines Corporation (IBM) personal computer/AT's bus structure.

ATA/66

ATA/66 uses both rising edge and falling edge but doubles [UDMA/33](#) transfer rate. The data transfer rate is 4 times of the PIO mode 4 or DMA mode 2, 16.6MB/s x4 = 66MB/s. To use ATA/66, you need special ATA/66 IDE cable.

ATA/100

ATA/100 is a new IDE specification under developing. ATA/100 uses both rising edge and falling edge as [ATA/66](#) but clock cycle time is reduced to 40ns. The data transfer rate is $(1/40\text{ns}) \times 2 \text{ bytes} \times 2 = 100\text{MB/s}$. To use ATA/100, you need special 80-wire IDE cable, the same as ATA/66.

ATA/133

Compared to traditional ATA/100, ATA/133 has been up to 33 percent increase in interface speed with transfer rate of 133MB/s. ATA/133 performance is ideal for new operating systems, such as Window XP, that demand more storage space and faster data transfer rates from more responsive computing experiences.

BIOS (Basic Input/Output System)

BIOS is a set of assembly routine/program that reside in [EPROM](#) or [Flash ROM](#). BIOS controls Input/output devices and other hardware devices of motherboard. In general, to provide hardware independent portability, operation system and drivers is required to access BIOS without directly access hardware devices.

Bus Master IDE (DMA mode)

The traditional PIO (Programmable I/O) IDE requires the CPU to involve in all the activities of the IDE access including waiting for the mechanical events. To reduce the workload of the CPU, the bus master IDE device transfers data from/to memory without interrupting CPU, and releases CPU to operate concurrently while data is transferring between memory and IDE device. You need the bus master IDE driver and the bus master IDE HDD to support bus master IDE mode.

CNR (Communication and Networking Riser)

The CNR specification provides the PC industry the opportunity to deliver a flexible and cost reduced method of implementing LAN, home networking, DSL, USB, wireless, audio and modem subsystems widely used in today's "connected PCs". The CNR specification is an open industry specification and is supported by OEMs, IHV card manufacturers, silicon supplier and Microsoft.

CODEC (Coding and Decoding)

Normally, CODEC means a circuit that can do digital to analog conversion and also the analog to digital conversion. It is part of [AC97](#) sound/modem solution.

DDR (Double Data Rated) SDRAM

DDR SDRAM utilizes the existing DRAM infrastructure and technology while doubling the nominal bandwidth available to systems in an easy to design and simple to adopt way. Initially a perfect solution for memory intensive server and workstation applications, DDR low cost and low voltage will ultimately make it an ideal solution for all segments of the PC market, high performance desktop and mobile PCs, Value PCs and even Internet Appliances and mobile devices.

DIMM (Dual In Line Memory Module)

DIMM socket has total 168-pin and supports 64-bit data. It can be single or double side, the golden finger signals on each side of PCB are different, and that is why it was called Dual In Line. Almost all DIMMs are made by [SDRAM](#), which operate at 3.3V. Note that some old DIMMs are made by FPM/[EDO](#) and only operate at 5V. Do not confuse them with SDRAM DIMM.

DMA (Direct Memory Access)

Channel for communications between the memory and surrounding devices.

ECC (Error Checking and Correction)

The ECC mode needs 8 ECC bits for 64-bit data. Each time memory is accessed; ECC bits are updated and checked by a special algorithm. The ECC algorithm has the ability to detect double-bit error and automatically correct single-bit error while parity mode can only detect single-bit error.

EDO (Extended Data Output) Memory

The EDO DRAM technology is actually very similar to FPM (Fast Page Mode). Unlike traditional FPM that tri-states the memory output data to start the pre-charge activity, EDO DRAM holds the memory data valid until the next memory access cycle, that is similar to pipeline effect and reduces one clock state.

EEPROM (Electronic Erasable Programmable ROM)

Also known as E²PROM. Both EEPROM and [Flash ROM](#) can be re-programmed by electronic signals, but the interface technology is different. Size of EEPROM is much smaller than flash ROM.

EPROM (Erasable Programmable ROM)

Traditional motherboard stores BIOS code in EPROM. EPROM can only be erased by ultra-violet (UV) light. If BIOS has to be upgraded, you need to remove EPROM from motherboard, clear by UV light, re-program, and then insert back.

EV6 Bus

EV6 Bus in the technology of Alpha processor from Digital Equipment Corporation. EV6 bus uses both rising and falling clock edge to transfer data, similar as DDR SDRAM or ATA/66 IDE bus.

EV6 Bus Speed = CPU external bus clock x 2.

For example, 200 MHz EV6 bus is actually using 100 MHz external bus clock, but the equivalent speed is 200 MHz.

FCC DoC (Declaration of Conformity)

The DoC is component certification standard of FCC EMI regulations. This standard allows DIY component (such as motherboard) to apply DoC label separately without a shielding of housing.

FC-PGA (Flip Chip-Pin Grid Array)

FC means Flip Chip, FC-PGA is a new package of Intel for Pentium III CPU. It can plug into SKT370 socket, but require motherboard to add some signals on socket 370. That is, the motherboard needs to be redesigned. Intel is going to ship FC-PGA 370 CPU and phase out slot1 CPU.

Flash ROM

Flash ROM can be re-programmed by electronic signals. It is easier for BIOS to upgrade by a flash utility, but it is also easier to be infected by virus. Because of increase of new functions, BIOS size is increased from 64KB to 256KB (2M bit). AOpen AX5T is the first board to implement 256KB (2Mbit) Flash ROM. Now flash ROM size is moving to 4M bit on AX6C (Intel 820) and MX3W (Intel 810) motherboard. , AOpen motherboard uses EEPROM for jumper-less and battery-less design.

FSB (Front Side Bus) Clock

FSB Clock means CPU external bus clock.

CPU internal clock = CPU FSB Clock x CPU Clock Ratio

I²C Bus

See [SMBus](#).

IEEE 1394

IEEE 1394 is a low-cost digital interface originated by Apple Computer as a desktop LAN and developed by the IEEE 1394 working group. The IEEE 1394 can transport data at 100, 200 or 400 Mbps. One of the solutions to connect digital television devices together at 200 Mbps. Serial Bus Management provides overall configuration control of the serial bus in the form of optimizing arbitration timing, guarantee of adequate electrical power for all devices on the bus, assignment of isochronous channel ID, and notification of errors. There are two type of IEEE 1394 data transfer: asynchronous and isochronous. Asynchronous transport is the traditional computer memory-mapped, load and store interface. Data requests are sent to a specific address and an acknowledgment is returned. In addition to an architecture that scales with silicon technology, IEEE 1394 features a unique isochronous data channel interface. Isochronous data channels provide guaranteed data transport at a pre-determined rate. This is especially important for time-critical multimedia data where just-in-time delivery eliminates the need for costly buffering.

Parity Bit

The parity mode uses 1 parity bit for each byte, normally it is even parity mode, that is, each time the memory data is updated, parity bit will be adjusted to have even count "1" for each byte. When next time, if memory is read with odd number of "1", the parity error is occurred and this is called single bit error detection.

PBSRAM (Pipelined Burst SRAM)

For Socket 7 CPU, one burst data read requires four QWord (Quad-word, $4 \times 16 = 64$ bits). PBSRAM only needs one address decoding time and automatically sends the remaining QWords to CPU according to a predefined sequence. Normally, it is 3-1-1-1, total 6 clocks, which is faster than asynchronous SRAM. PBSRAM is often used on L2 (level 2) cache of Socket 7 CPU. Slot 1 and Socket 370 CPU do not need PBSRAM.

PC-100 DIMM

[SDRAM](#) DIMM that supports 100MHz CPU [FSB](#) bus clock.

PC-133 DIMM

[SDRAM](#) DIMM that supports 133MHz CPU [FSB](#) bus clock.

PC-1600, PC-2100 or PC-2700 DDR DRAM

Based on FSB frequency, the DDR DRAM has 200MHz, 266MHz and 333MHz three types of working frequency. Because DDR DRAM data bus is 64-bit, it provides data transfer bandwidth up to $200 \times 64 / 8 = 1600 \text{MB/s}$, $266 \times 64 / 8 = 2100 \text{MB/s}$ and $333 \times 64 / 8 = 2700 \text{MB/s}$ in these current three DDR DRAM. Therefore, the PC-1600 DDR DRAM is working with 100MHz, PC-2100 DDR DRAM is working with 133MHz and PC-2700 with 166MHz FSB frequency.

PCI (Peripheral Component Interface) Bus

Bus for the internal connection of peripheral devices, high-speed data channel between the computer and expansion card.

PDF Format

A file format for electronic document, PDF format is independent from platform, you can read PDF file under Windows, Unix, Linux, Mac ... with different PDF reader. You can also read PDF file by web browser such as IE and Netscape, note that you need to install PDF plug-in first (Included in Acrobat Reader).

PnP (Plug and Play)

The PnP specification suggests a standard register interface for both BIOS and operating system (such as Windows 95). These registers are used by BIOS and operating system to configure system resource and prevent any conflicts. PnP BIOS or operating system will automatically allocate the IRQ/DMA/Memory. Currently, almost all the PCI cards and most ISA cards are already PnP compliant.

POST (Power-On Self Test)

The BIOS self-test procedure after power-on, sometimes, it is the first or the second screen shown on your monitor during system boot.

RDRAM (Rambus DRAM)

Rambus is a memory technology that uses large burst mode data transfer. Theoretically, the data transfer should be high than [SDRAM](#). RDRAM is cascaded in channel operation. For Intel 820, only one RDRAM channel is supported, 16-bit data per channel, and this channel may have maximum 32 RDRAM devices, no matter how many [RIMM](#) sockets.

RIMM (Rambus Inline Memory Module)

184-pin memory module that supports [RDRAM](#) memory technology. A RIMM memory module may contain up to maximum of 16 RDRAM devices.

SDRAM (Synchronous DRAM)

SDRAM is one of the DRAM technologies that allow DRAM to use the same clock as the CPU host bus ([EDO](#) and FPM are asynchronous and do not have clock signal). It is similar as [PBRAM](#) to use burst mode transfer. SDRAM comes in 64-bit 168-pin [DIMM](#) and operates at 3.3V. AOpen is the first company to support dual-SDRAM DIMMs onboard (AP5V), from Q1 1996

Shadow E²PROM

A memory space in Flash-ROM to simulate E²PROM operation, AOpen motherboard uses Shadow E²PROM for jumper-less and battery-less design

SIMM (Single In Line Memory Module)

SIMM socket is only 72-pin, and is only single side. The golden finger signals on each side of PCB are identical. That is why it was called Single In Line. SIMM is made by FPM or [EDO](#) DRAM and supports 32-bit data. SIMM had been phased out on current motherboard design.

SMBus (System Management Bus)

SMBus is also called I2C bus. It is a two-wire bus developed for component communication (especially for semiconductor IC). For example, set clock of clock generator for jumper-less motherboard. The data transfer rate of SMBus is only 100Kbit/s, it allows one host to communicate with CPU and many masters and slaves to send/receive message.

SPD (Serial Presence Detect)

SPD is a small ROM or [EEPROM](#) device resided on the [DIMM](#) or [RIMM](#). SPD stores memory module information such as DRAM timing and chip parameters. SPD can be used by [BIOS](#) to decide best timing for this DIMM or RIMM.

Ultra DMA

Ultra DMA (or, more accurately, Ultra DMA/33) is a protocol for transferring data between a hard disk drive through the computer's data path (or bus) to the computer's random access memory (RAM). The Ultra DMA/33 protocol transfers data in burst mode at a rate of 33.3MB/s, twice as fast as the previous [Direct Access Memory \(DMA\)](#) interface. Ultra DMA was developed as a proposed industry standard by the Quantum corporation, makes of hard disk drives, and Intel, makes of chipset that support computer bus technology. Ultra DMA support in your computer means that it will boot (start) and open new applications more quickly. It will help users of graphic-intensive and applications that require large amounts of access to data on the hard disk drive. Ultra DMA uses Cyclical Redundancy Checking (CRC), offering a new level of data protection. Ultra DMA uses the same 40-pin IDE interface cable as PIO and DMA.

16.6MB/s x2 = 33MB/s

16.6MB/s x4 = 66MB/s

16.6MB/s x6 = 100MB/s

USB (Universal Serial Bus)

USB is a 4-pin serial peripheral bus that is capable of cascading low/medium speed peripherals (less than 10Mbit/s) such as keyboard, mouse, joystick, scanner, printer and modem. With USB, the traditional complex cables from back panel of your PC can be eliminated.

USB2.0 (Universal Serial Bus)

Compared to traditional USB 1.0/1.1 with the speed of 12Mbps, USB 2.0 has a fancy speed up to 480 Mbps that is 40 times faster than the traditional one. Except for the speed increase, USB 2.0 supports old USB 1.0/1.1 software and peripherals, offering impressive and even better compatibility to customers.

VCM (Virtual Channel Memory)

NEC's Virtual Channel Memory (VCM) is a new DRAM core architecture that dramatically improves the memory system's ability to service multimedia requirements. VCM increases memory bus efficiency and performance of any DRAM technology by providing a set of fast static registers between the memory core and I/O pins. Using VCM technology results in reduced data access latency and reduced power consumption.

ZIP file

A compressed file format to reduce file size. To unzip file, run shareware PKUNZIP (<http://www.pkware.com/>) for DOS and other operating system or WINZIP (<http://www.winzip.com/>) for windows environment.



Troubleshooting

If you encounter any trouble to boot you system, follow the procedures accordingly to resolve the problem.

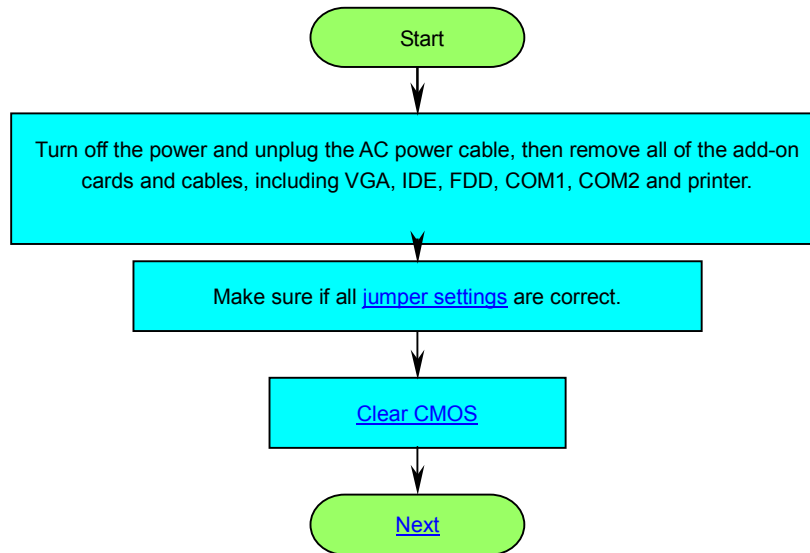

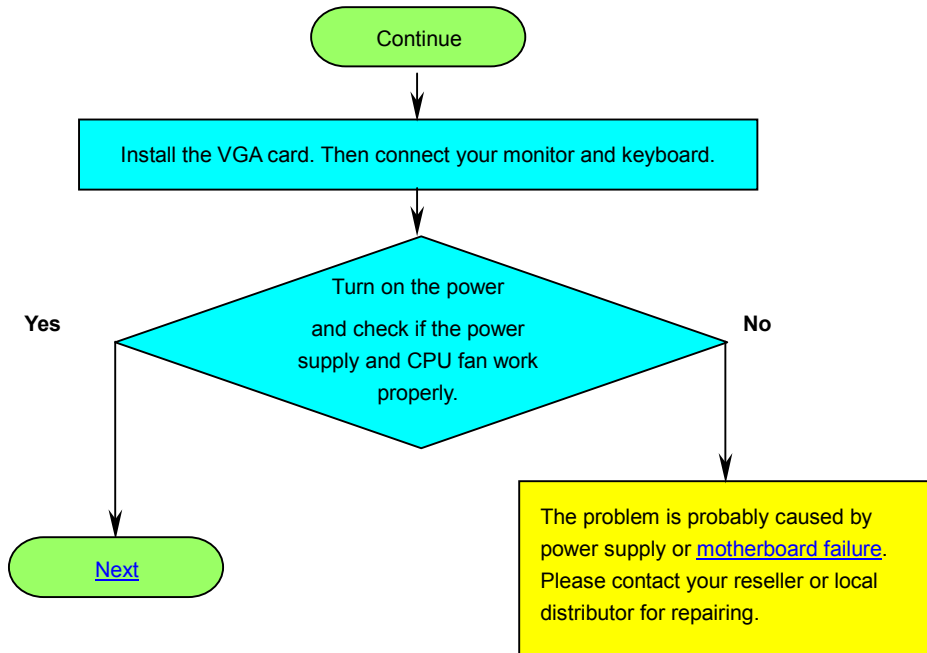

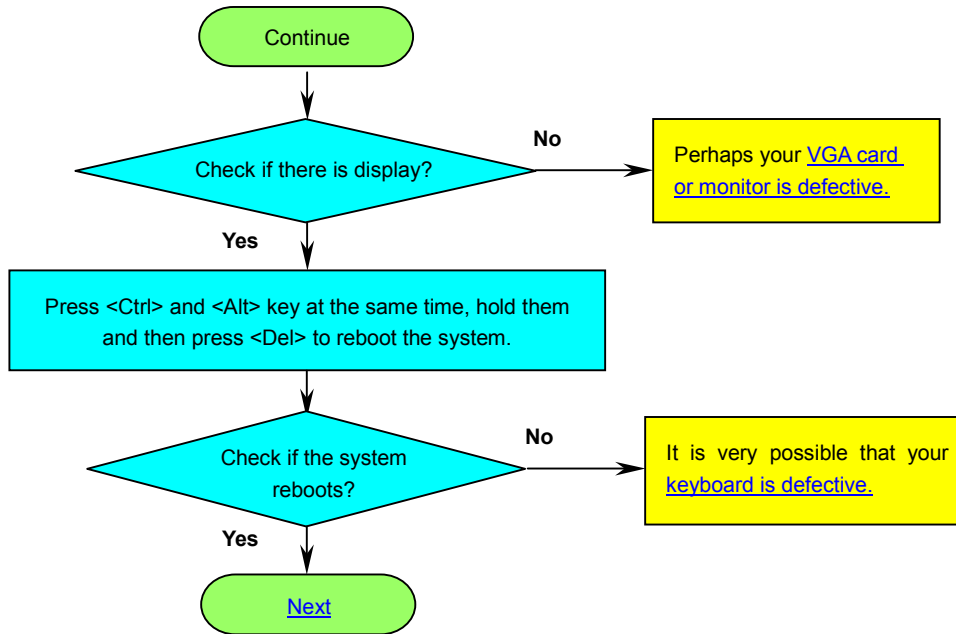

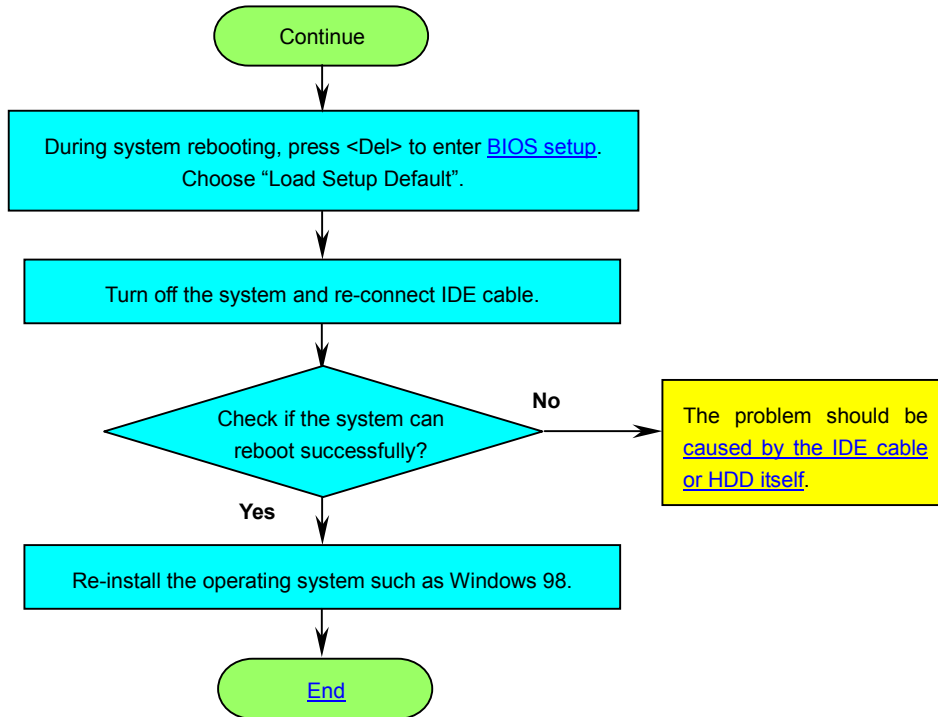



Technical Support

Dear Customer,

Thanks for choosing AOpen products. To provide the best and fastest service to our customer is our first priority. However, we receive numerous emails and phone-calls worldwide everyday, it is very hard for us to serve everyone on time. We recommend you follow the procedures below and seek help before contact us. With your help, we can then continue to provide the best quality service to more customers.

Thanks very much for your understanding!

AOpen Technical Supporting Team

1

Online Manual: Please check the manual carefully and make sure the jumper settings and installation procedure are correct.
<http://english.aopen.com.tw/tech/download/manual/default.htm>

2

Test Report: We recommend choosing board/card/device from the compatibility test reports for assembling your PC.
<http://english.aopen.com.tw/tech/report/default.htm>

3

FAQ: The latest FAQ (Frequently Asked Questions) may contain a solution to your problem.
<http://english.aopen.com.tw/tech/faq/default.htm>

4

Download Software: Check out this table to get the latest updated BIOS/utility and drivers.
<http://english.aopen.com.tw/tech/download/default.htm>

5

News Group: Your problem probably had been answered by our support engineer or professional users on the news group.
<http://english.aopen.com.tw/tech/newsgrp/default.htm>

6

Contact Distributors/Resellers: We sell our products through resellers and integrators. They should know your system configuration very well and should be able to solve your problem efficiently and provide important reference for you if next time you want to buy something else from them.

7

Contact Us: Please prepare detail system configuration and error symptom before contacting us. The **part number**, **serial number** and **BIOS version** are also very helpful.

Part Number and Serial Number

The Part Number and Serial number are printed on bar code label. You can find this bar code label on the outside packing or on component side of PCB. For example:



Part No.

Serial No.



Part No.

Serial No.

P/N: 91.88110.201 is part number, **S/N: 91949378KN73** is serial number.

Model name and BIOS version

Model name and BIOS version can be found on upper left corner of first boot screen ([POST](#) screen). For example:

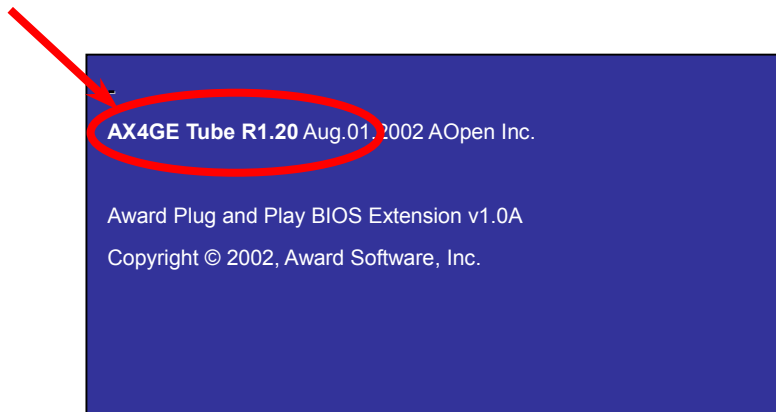

AX4GE Tube is model name of motherboard; **R1.20** is BIOS version.



Product Registration



Thank you for choosing AOpen product. AOpen encourages you to spend few minutes in completing the following product registration. To register your product will ensure the high quality of services from AOpen. After the registration, you will:

- Have opportunities to play online slot machine and win a prize from AOpen by accumulating your bonuses for later prize exchange.
- Be upgraded to gold membership of Club AOpen program.
- Receive email notification about product safety alerts. Its purpose is to alert consumers quickly and conveniently when products contain technical issues.
- Receive email notification about latest product's announcements.
- Be able to personalize your AOpen web pages.
- Receive e-mail notification about latest BIOS/Driver/Software release information.
- Have opportunities to participate special product promotional programs.
- Enjoy higher service priority to receive technical assistance provided by AOpen specialists worldwide.
- Be able to join the discussions of web-based news groups.

AOpen makes sure that the information you provide is encrypted, so that it cannot be read or intercepted by other people or companies. Further, AOpen will not disclose any of information you submitted under any conditions. Please consult our [online privacy policy](#) for further information on our company policy.

Note: *If registering products purchased from different dealers/retails and/or purchased on different dates, please submit a separate form for each product.*



How to Contact Us



Please do not hesitate contact us if you have any problem about our products. Any opinion will be appreciated.

Pacific Rim

AOpen Inc.

Tel: 886-2-3789-5888

Fax: 886-2-3789-5899

Europe

AOpen Computer b.v.

Tel: 31-73-645-9516

Fax: 31-73-645-9604

America

AOpen America Inc.

Tel: 1-510-489-8928

Fax: 1-510-489-1998

China

艾爾鵬國際貿易(上海)有限公司

Tel: 86-21-6225-8622

Fax: 86-21-6225-7926

Germany

AOpen Computer GmbH.

Tel: 49-1805-559191

Fax: 49-2102-157799

Japan

AOpen Japan Inc.

Tel: 81-048-290-1800

Fax: 81-048-290-1820

Web Site: <http://www.aopen.com.tw>

E-mail: Send us email by going through the contact form below.

English <http://english.aopen.com.tw/tech/default.htm>

Japanese <http://www.aopen.co.jp/tech/default.htm>

Chinese <http://www.aopen.com.tw/tech/default.htm>

German <http://www.aopencom.de/tech/default.htm>

Simplified Chinese <http://www.aopen.com.cn/tech/default.htm>

