

AX45F-1394







Online Manual

DOC. NO.: AX45F1394-OL-E0306A

What's in this manual

AX45F-1394	1
<i>What's in this manual</i>	2
<i>You Must Notice</i>	8
<i>Before You Start</i>	9
<i>Overview</i>	10
<i>Feature Highlight</i>	11
<i>Quick Installation Procedure</i>	15
<i>Motherboard Map</i>	16
<i>Block Diagram</i>	17
Hardware Installation	18
<i>About "User Upgrade Optional" and "Manufacture Upgrade Optional"</i>	19
<i>CPU Installation</i>	20
<i>Hyper Threading Technology</i>	23
<i>CPU Jumper-less Design</i>	25
<i>CPU Over-current Protection</i>	26
<i>AOpen "Watch Dog ABS"</i>	27
<i>CPU and System Fan Connector (with H/W Monitoring)</i>	31
<i>DIMM Sockets</i>	32



	Front Panel Connector	34
	ATX Power Connector.....	35
	AC Power Auto Recovery.....	35
	IDE and Floppy Connector.....	36
	ATA/133 Supported	38
	IrDA Connector.....	39
	Support AGP 8X (Accelerated Graphic Port) Expansion Slot	40
	AGP Protection Technology and AGP LED	41
	WOM (Zero Voltage Wake on Modem) Connector.....	42
	WOM by External BOX Modem.....	43
	WOM by Internal Modem Card.....	44
	WOL (Wake on LAN) Connector.....	45
	Support 10/100 Mbps LAN onboard.....	47
	CNR (Communication and Network Riser) Expansion Slot.....	48
	Support USB 2.0 Ports	49
	IEEE 1394 Connectors.....	50
	Colored Back Panel.....	51
	S/PDIF (Sony/Philips Digital Interface) Connector.....	52
	Super 5.1 Channel Audio Effect	53



Front Audio Connector 54

Dr. LED Connector (User Upgrade Optional) 55

Case Open Connector..... 57

CD Audio Connector..... 58

AUX-IN Connector..... 59

Game Port Bracket Supported 60

JP2 Speaker Output Jumper 61

JP14 Clear CMOS Data 62

JP15/JP16 Dr. Voice II Language Select Jumpers..... 63

JP27 / JP28 Keyboard/Mouse Wake-up Jumper 64

JP29 DDR Voltage Jumper 65

STBY LED 66

Enlarged Aluminum Heatsink 67

Resettable Fuse 68

3300µF Low ESR Capacitor..... 69

NEW! *AOConfig Utility* 71

NEW! *The noise is gone!! --- SilentTek*..... 73

NEW! *EzClock* 76

Phoenix-AWARD BIOS **80**





How To Use Phoenix-Award™ BIOS Setup Program 81

How To Enter BIOS Setup..... 82

BIOS Upgrade under Windows environment 83

WinBIOS Utility..... 85

Vivid BIOS technology..... 87

Driver and Utility..... **88**

Auto-run Menu from Bonus CD..... 88

Installing AGP Driver 89

Installing Onboard Sound Driver 90

Installing IDE Driver..... 91

Installing LAN Driver..... 92

Installing USB 2.0 Driver 95

Glossary **96**

AC97 CODEC 96

ACPI (Advanced Configuration & Power Interface)..... 96

ACR (Advanced Communication Riser) 96

AGP (Accelerated Graphic Port) 97

AMR (Audio/Modem Riser) 97

ATA (AT Attachment) 97



BIOS (Basic Input/Output System) 98

Bluetooth 98

CNR (Communication and Networking Riser) 99

DDR (Double Data Rate) RAM 99

ECC (Error Checking and Correction) 99

EEPROM (Electronic Erasable Programmable ROM) 99

EPROM (Erasable Programmable ROM) 100

EV6 Bus 100

FCC DoC (Declaration of Conformity) 100

FC-PGA (Flip Chip-Pin Grid Array) 100

FC-PGA2 (Flip Chip-Pin Grid Array) 100

Flash ROM 101

Hyper Threading 101

IEEE 1394 101

Parity Bit 102

PCI (Peripheral Component Interface) Bus 102

PDF Format 102

PnP (Plug and Play) 102

POST (Power-On Self Test) 103



<i>PSB (Processor System Bus) Clock</i>	103
<i>RDRAM (Rambus Dynamic Random Access Memory)</i>	103
<i>RIMM (Rambus Inline Memory Module)</i>	103
<i>SDRAM (Synchronous DRAM)</i>	103
<i>SATA (Serial ATA)</i>	104
<i>SMBus (System Management Bus)</i>	104
<i>SPD (Serial Presence Detect)</i>	104
<i>USB 2.0 (Universal Serial Bus)</i>	104
<i>VCM (Virtual Channel Memory)</i>	105
<i>Wireless LAN – 802.11b</i>	105
<i>ZIP file</i>	105
Troubleshooting	106
Technical Support	110
Product Registration	114
How to Contact Us	115

You Must Notice



Adobe, the Adobe logo, Acrobat is trademarks of Adobe Systems Incorporated.

AMD, the AMD logo, Athlon and Duron are trademarks of Advanced Micro Devices, Inc.

Intel, the Intel logo, Intel Celeron, Pentium II, Pentium III and Pentium 4 are trademarks of Intel Corporation.

Microsoft, Windows, and Windows logo are either registered trademarks or trademarks of Microsoft Corporation in the United States and/or other countries.

All product and brand names used on this manual are used for identification purposes only and may be the registered trademarks of their respective owners.

All of the specifications and information contained in this manual are subject to change without notice. AOpen reserves the right to revise this publication and to make reasonable changes. AOpen assumes no responsibility for any errors or inaccuracies that may appear in this manual, including the products and software described in it.

This documentation is protected by copyright law. All rights are reserved.

No part of this document may be used or reproduced in any form or by any means, or stored in a database or retrieval system without prior written permission from AOpen Corporation.

Copyright® 1996-2003, AOpen Inc. All Rights Reserved.

Before You Start



This Online Manual will introduce to the user how this product is installed. All useful information will be described in later chapters. Please keep this manual carefully for future upgrades or system configuration changes. This Online Manual is saved in [PDF format](#), we recommend using Adobe Acrobat Reader 5.0 for online viewing, it is included in Bonus CD or you can get free download from [Adobe web site](#).

Although this Online Manual is optimized for screen viewing, it is still capable for hardcopy printing; you can print it by A4 paper size and set 2 pages per A4 sheet on your printer. To do so, choose **File > Page Setup** and follow the instruction of your printer driver.

Thanks for the help of saving our earth.

Overview

Thank you for choosing AOpen AX45F-1394 motherboard. AX45F-1394 is Intel® Socket 478 motherboard (M/B) based on the ATX form factor featuring the [SIS 648FX chipset](#). As high performance chipset built in the M/B, AX45F-1394 motherboard supports Intel® Socket 478 Pentium® 4 1.6GHz~3.20GHz and 400/533/800 MHz [Front Side Bus \(FSB\)](#) clock. It also supports Intel [Hyper-Threading](#) Technology which brings additional intelligence to system. In the [AGP](#) performance, it has one AGP slot and supports AGP 8X mode pipelined spilt-transaction long burst transfer up to 2112MB/sec. According to different customer's requirements, AX45F-1394 supports [DDR](#) 400/333/266 RAM up to 3GB maximum. The onboard IDE controller supports [Ultra DMA 66/100/133](#) mode. There are 6 PCI slots provided on this board and two [IEEE1394](#) connectors which provide data transfer rate up to 400Mb/s. Further flexibility can be achieved by taking advantage of the [Communication and Network Riser \(CNR\)](#) card option that allows audio and modem configuration on a single baseboard design. A total of 4 [USB 2.0](#) ports on the back panel and one header on board give you the best use of all USB devices at the fancy speed up to 480Mbps. More than that, on the strength of Realtek 8100BL LAN controller on board, which is a highly-integrated Platform LAN Connect device, it provides 10/100M bps Ethernet for office and home use. Besides, AX45F-1394 has a [S/PDIF](#) connector and an [AC97 CODEC](#) chipset onboard, providing high performance and magic surround stereo sound to let people enjoy working with it. Now, let's enjoy all features from AOpen AX45F-1394 motherboard.

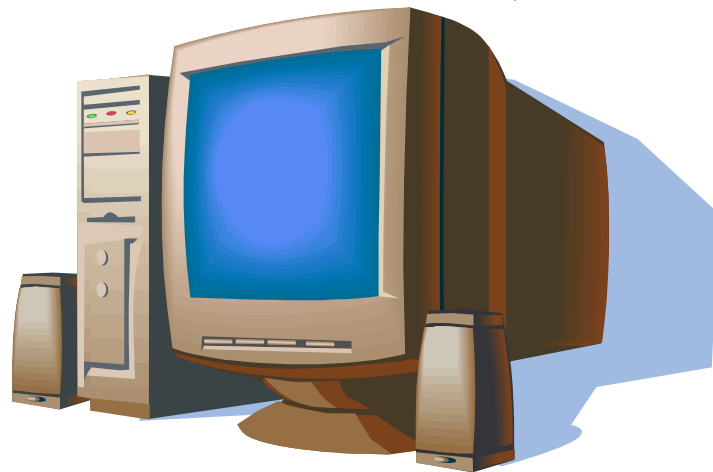

Feature Highlight

CPU

Supports Intel® Socket 478 Pentium® 4 1.6GHz~3.20GHz+ with 400/533/800 MHz Front Side Bus (FSB) designed for Socket 478 technology. The AX45F-1394 motherboard supports Intel Hyper-Threading Technology.

Chipset

The motherboard is equipped with SIS 648FX chipset. The SIS 648FX Host & Memory & AGP Controller integrates a high performance host interface for Intel Pentium 4 processor, a high performance memory controller, an AGP interface and SiS MuTIOL 1G Technology connecting with SiS963L MuTIOL 1G Media IO. The host interface plays the role of processor transactions' dispatcher. It dispatches transactions to Memory, I/O interface and AGP bus. Transactions to different destinations can be dispatched concurrently in order to maximum pipeline efficiency. The Memory controller supports DDR 400/333/266 RAM and the Suspend to RAM function by retaining the CKE# pins asserted in ACPI S3 state in which only AUX source deliver power. The AGP interface supports external AGP slot with AGP 4X/8X capability and Fast Write Transactions.

Expansion Slots

Including six 32-bit/33MHz PCI, one CNR and one AGP 4X/8X slots. The PCI local bus throughput can be up to 132MB/s. The [Communication & Networking Riser \(CNR\)](#) slot provided in AX45F-1394 supports CNR interface for a Modem/Audio card. The [Accelerated Graphics Port \(AGP\)](#) specification provides a new level of video display sophistication and speed. And the data transfer rate can be up to 2112MB/s. Of six PCI slots provided, except the first PCI slot is slave, all other five slots are master PCI slots with arbitration and decoding for all integrated functions and LPC bus.

Memory

Provides three 184-pin DDR DIMM sockets that support [DDR 400/333/266](#) composed of an arbitrary mixture of 64, 128, 256, 512 MB or 1GB RAM up to 3 GB maximum.

Hyper-Threading Technology

Support Hyper-Threading Technology which brings additional intelligence to systems so that multiple tasks received from the processor can be managed and prioritized more effectively.

Watch Dog ABS

Includes AOpen “Watch Dog ABS” function that can auto-reset system in 4.8 seconds when you fail the system overclocking.

1MHz Stepping Frequency Adjustment

Provides “1MHz Stepping Frequency Adjustment” function in the BIOS. This magic function allows you to adjust CPU FSB frequency from 100~248MHz by 1MHz stepping adjustment, and helps your system get maximum performance.

LAN Port

On the strength of Realtek 8100BL LAN controller on board, which is a highly-integrated Platform LAN Connect device, it provides 10/100 Mbps Ethernet for office and home use.

Ultra DMA 66/100/133 Bus Master IDE

Comes with an on-board PCI Bus Master IDE controller with two connectors that support four IDE devices in two channels, supports [Ultra DMA 66/100/133](#), PIO Modes 3 and 4 and Bus Master IDE DMA Mode 5, and supports Enhanced IDE devices.

On-board AC'97 Sound

AX45F-1394 uses RealTek ALC650 AC97 sound chip. This on-board audio includes a complete audio recording and playback system.

Six USB 2.0 Ports

Provides four ports on the back panel and one header on board to connect USB 2.0 interface devices, such as mouse, keyboard, modem, scanner, etc.

AGP Protection Technology

With AGP Protection Technology implemented, this motherboard will automatically detect the voltage of AGP card and prevent your chipsets from being burnt out.

Dr. Voice II

The Dr. Voice II can identify what kind of problems had occurred in the operating system. It provides English, Chinese, Japanese and German four kinds language versions.

S/PDIF Connectors

S/PDIF (Sony/Philips Digital Interface) is the newest audio transfer file format, which provides impressive quality through optical fiber and allows you to enjoy digital audio instead of analog audio.

On-board IEEE 1394 Connectors

Comes with two onboard [IEEE 1394](#) (IEEE-1394a-2000) fully compliant cable ports at 100/200/400 Mbs/sec for you to connect IEEE 1394 devices, such as digital camera or other IEEE 1394 storage devices.

Power Management/Plug and Play

Supports the power management function that conforms to the power-saving standards of the U.S. Environmental Protection Agency (EPA) Energy Star program. It also offers [Plug-and-Play](#), which helps save users from configuration problems, thus making the system much user-friendlier.

Hardware Monitoring Management

Supports CPU or system fans status, temperature and voltage monitoring and alert, through the on-board hardware monitor module.

SilentTek

Combines “Hardware-Status Monitoring”, “Overheat Warning” and “Fan Speed Control” with user-friendly interfaces to provide a perfect balance among noises, system performance and stability.

Quick Installation Procedure

This page gives you a quick procedure on how to install your system. Follow each step accordingly.

1. [Installing CPU and Fan](#)
2. [Installing System Memory \(DIMM\)](#)
3. [Connecting Front Panel Cable](#)
4. [Connecting IDE and Floppy Cable](#)
5. [Connecting ATX Power Cable](#)
6. [Connecting Back Panel Cable](#)
7. [Power-on and Load BIOS Setup Default](#)
8. [Setting CPU Frequency](#)
9. Reboot
10. Installing Operating System (such as Windows XP)
11. [Installing Driver and Utility](#)

Motherboard Map

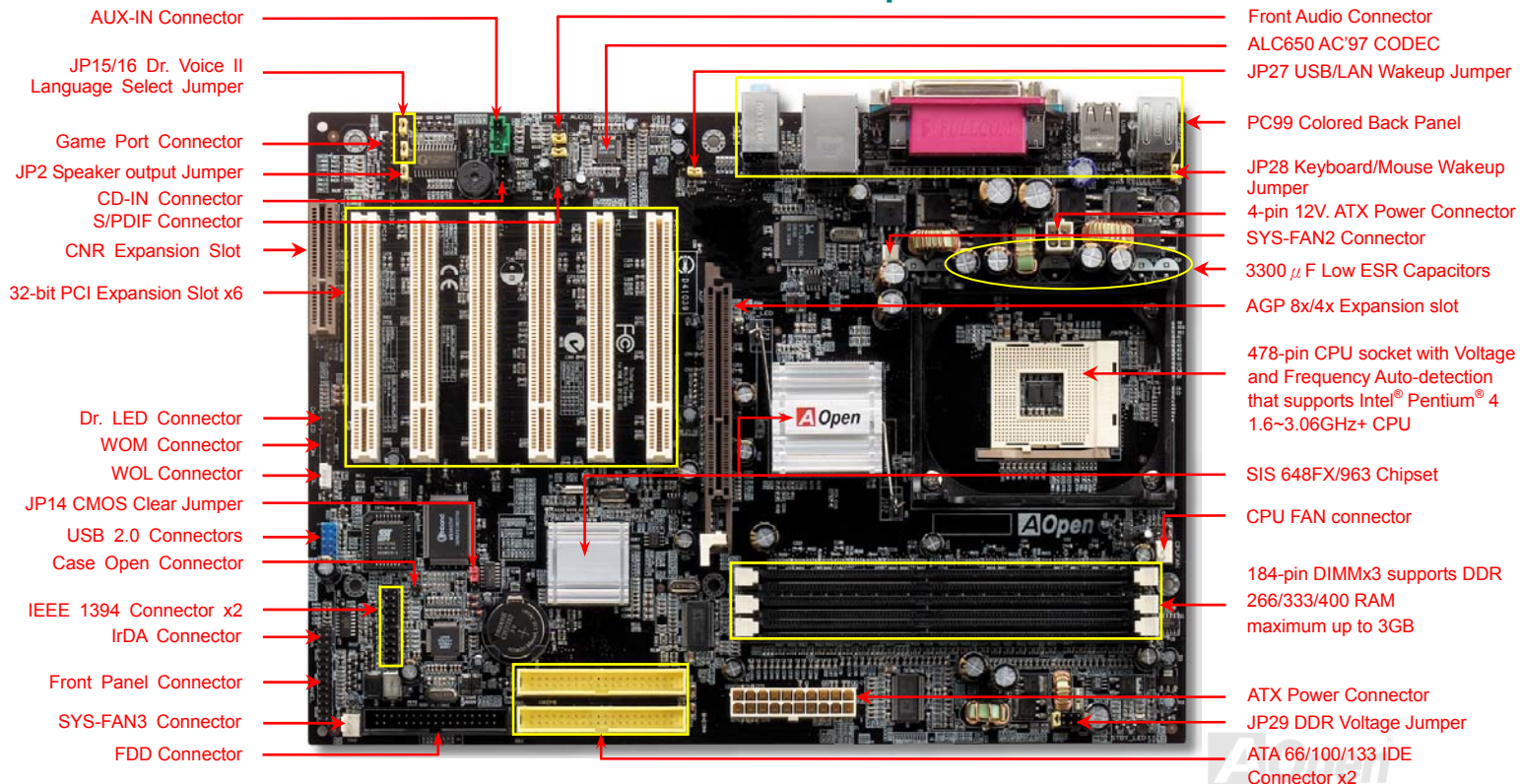

Block Diagram

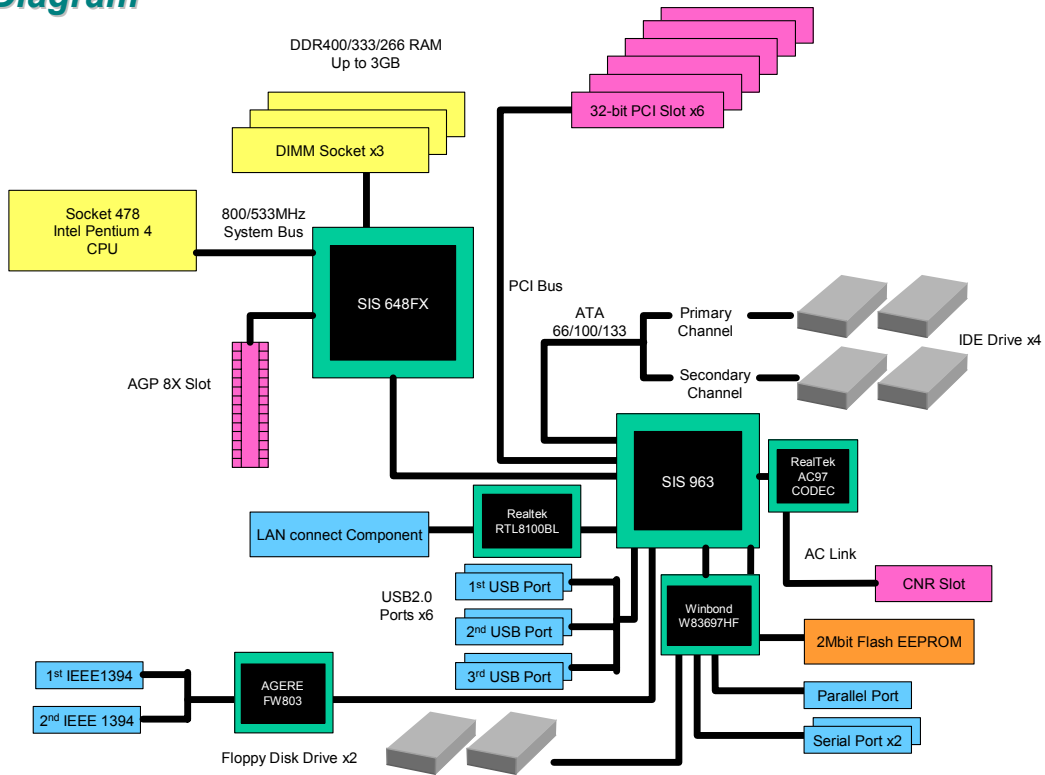

Hardware Installation

This chapter describes jumpers, connectors and hardware devices of this motherboard.



Note: *Electrostatic discharge (ESD) can damage your processor, disk drives, expansion boards, and other components. Always observe the following precautions before you install a system component.*

1. *Do not remove a component from its protective packaging until you are ready to install it.*
2. *Wear a wrist ground strap and attach it to a metal part of the system unit before handling a component. If a wrist strap is not available, maintain contact with the system unit throughout any procedure requiring ESD protection.*

About “User Upgrade Optional” and “Manufacture Upgrade Optional”...

When you read this online manual and start to assemble your computer system, you may notice that some of the functions are marked as “User Upgrade Optional” or “Manufacture Upgrade Optional”. Although all of AOpen’s motherboards have included many amazing and powerful features, sometimes not every user is familiar with these powerful features. As a result of this we define features that can be upgraded by users as “User Upgrade Optional”. You can upgrade these functions by purchasing additional devices. As for functions that cannot be upgraded by users, we define them as “Manufacture Upgrade Optional”. If need be, you can contact our local distributors or resellers to purchase “Manufacture Upgrade Optional” components, and again you are also welcome to visit our official website at www.aopen.com for detail information.



CPU Installation

This motherboard supports Intel® Pentium 4 Socket 478 series CPU (Willamette / Northwood). Be careful of CPU orientation when you plug it into CPU socket.

1. Pull up the CPU socket lever and up to 90-degree angle.
2. Locate Pin 1 in the socket and look for mark on the CPU upper interface. Match Pin 1 and cut edge, then insert the CPU into the socket.

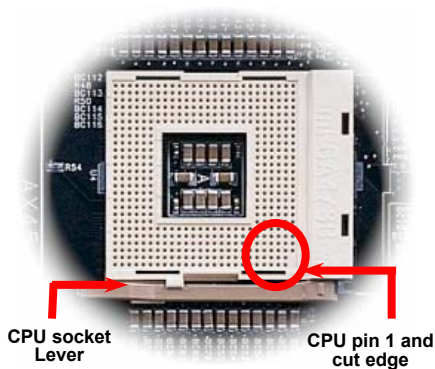
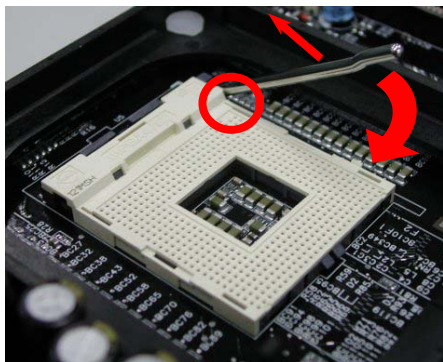

Note: Those pictures are for example only; they may not look the same with the motherboard you purchased.

3. Press down the CPU socket lever and finish CPU installation.

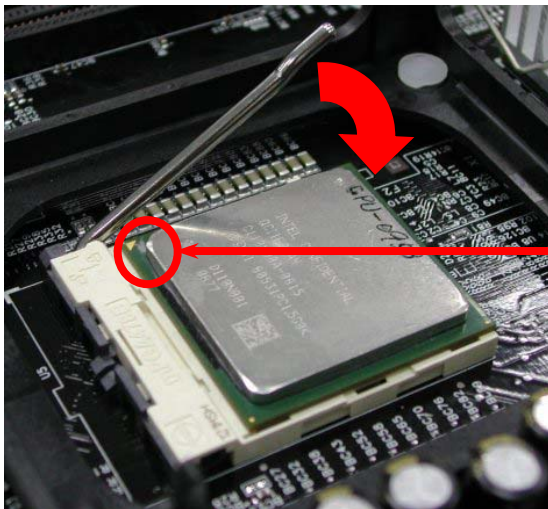

CPU cut edge

Note: If you do not match the CPU socket Pin 1 and CPU cut edge well, you may damage the CPU.

Note: This socket supports Micro-FC-PGA2 package CPU, which is the latest CPU package developed by Intel. Other forms of CPU package are impossible to be fitted in.

Note: This picture is for example only; it may not look the same with the motherboard you purchased.

CPU Fan Installation

This motherboard comes with a retention module attached on the CPU socket when shipped, we strongly recommend you to install AOpen special designed CPU Fan as shown below on the retention module for better heat dissipation. Please install the CPU Fan correctly as the following pictures shown.

1. Gently put the CPU Fan down on the retention module with clips aligning correctly to the four corners.

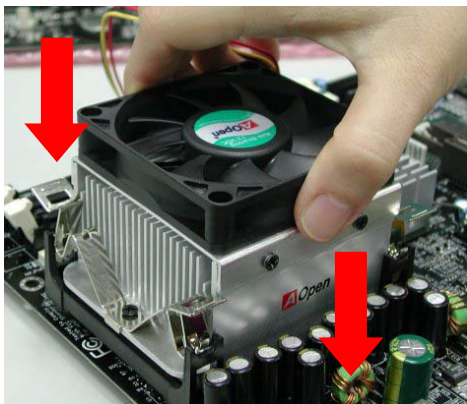

2. Pressing down the four clips with force one by one on the retention module.

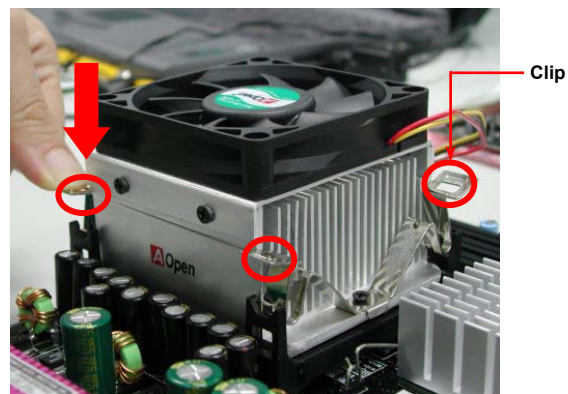

Hyper Threading Technology

What is Hyper-Threading?

Hyper-Threading technology is an innovative design from Intel that enables multi-threaded software applications to process threads in parallel within each processor resulting in increased utilization of processor execution resources. As a result, an average improvement of ~40% in CPU resource utilization yields higher processing throughput.

How Hyper-Threading Works

A form of simultaneous multi-threading technology (SMT), Hyper-Threading technology allows multiple threads of software applications to

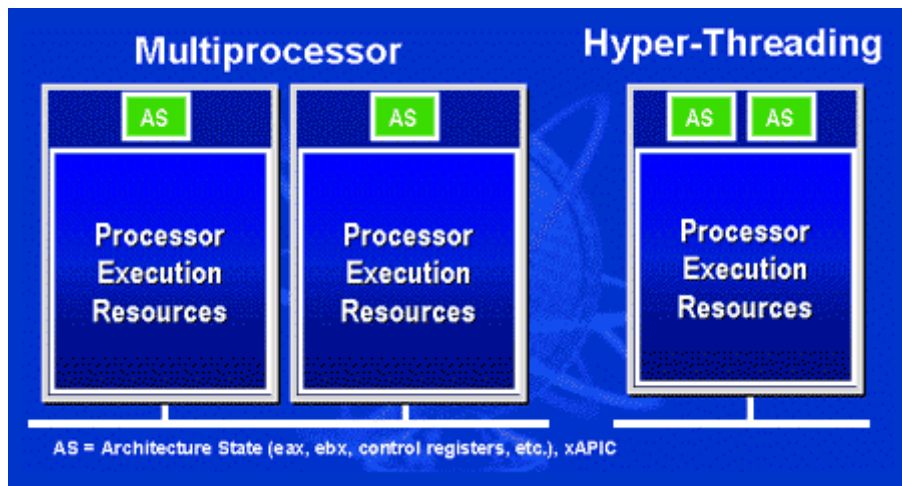

be run simultaneously on one processor by duplicating the architectural state on each processor while the same processor execution resources is shared. The figure below represents how a Hyper-Threading based processor differentiates a traditional multiprocessor. The left-hand configuration shows a traditional multiprocessor system with two physical processors. Each processor has its own independent execution resources and architectural state. The right-hand configuration represents an Intel Hyper-Threading technology based processor. You can see that the architectural state for each processor is duplicated, while the execution resources is shared.

For multiprocessor-capable software applications, the Hyper-Threading based processor is considered two separate logical processors on which the software applications can run without modification. Also, each logical processor responds to interrupts independently. The first logical processor can track one software thread, while the second logical processor tracks another software thread simultaneously. Because the two threads share the same execution resources, the second thread can use resources that would be otherwise idle if only one thread was executing. This results in an increased utilization of the execution resources within each physical processor.

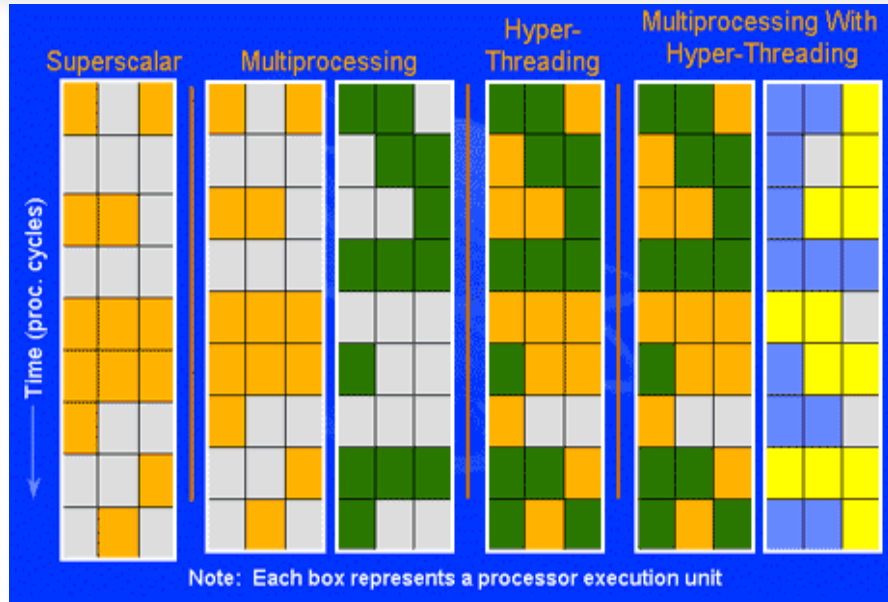

The figure below represents how Hyper-Threading saves time when it works. With two logical processors available on every single physical processor, multi-threaded applications can now take advantage of thread-level parallelism on each physical processor for additional performance. As software applications continue to be optimized to take greater advantage of processor parallelism, Hyper-Threading technology provides an additional boost for newer capabilities and the growing needs of today's users.



CPU Jumper-less Design

CPU VID signal and [SMbus](#) clock generator provide CPU voltage auto-detection and allows the user to set the CPU frequency through the BIOS setup, therefore no jumpers or switches are used. The disadvantages of the Pentium based jumper-less designs are eliminated. There will be no worry of wrong CPU voltage detection.

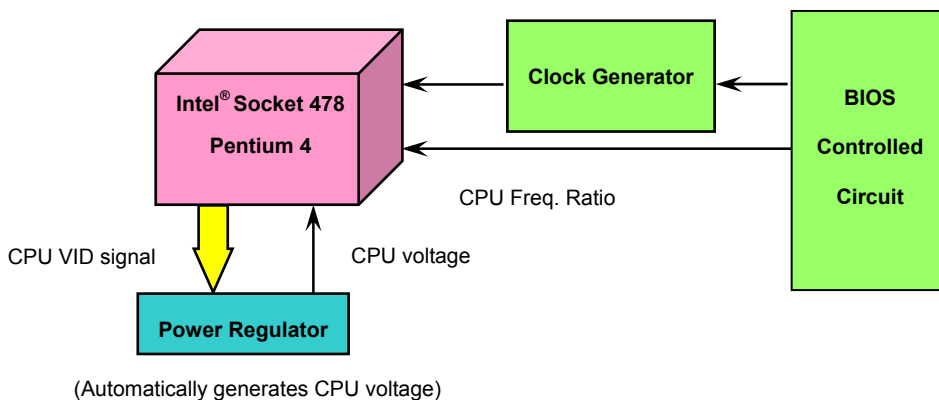

CPU Over-current Protection

The Over Current Protection is a popular implementation on ATX 3.3V/5V/12V switching power supply. However, the new generation CPU uses different voltage with a regulator to transfer 12V to CPU voltage (for example, 2.0V), and thus makes 5V over current protection useless. This motherboard is with switching regulator onboard supporting CPU over-current protection; in conjunction with 3.3V/5V/12V power supply provide the full line over-current protection.

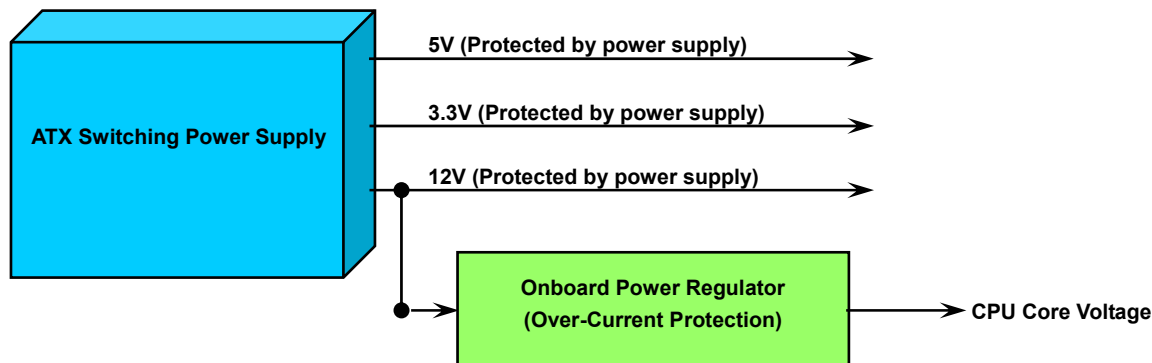

Note: Although we have implemented protection circuit try to prevent any human operating mistake, there is still certain risk that CPU, memory, HDD, add-on cards installed on this motherboard may be damaged because of component failure, human operating error or unknown nature reason. **AOpen cannot guaranty the protection circuit will always work perfectly.**

AOpen “Watch Dog ABS”



AOpen provides a special and useful feature on this motherboard for overclockers. When you power-on the system, the BIOS will check last system [POST](#) status. If it succeeded, the BIOS will enable “Watch Dog ABS” function immediately, and set the CPU FSB frequency according to user’s settings stored in the BIOS. If system failed in BIOS POST, the “Watch Dog Timer” will reset the system to reboot in five seconds. Then, BIOS will detect the CPU’s default frequency and POST again. With this special feature, you can easily overclock your system to get a higher system performance without removing the system housing and save the hassle from setting the jumper to clear CMOS data when system hangs.

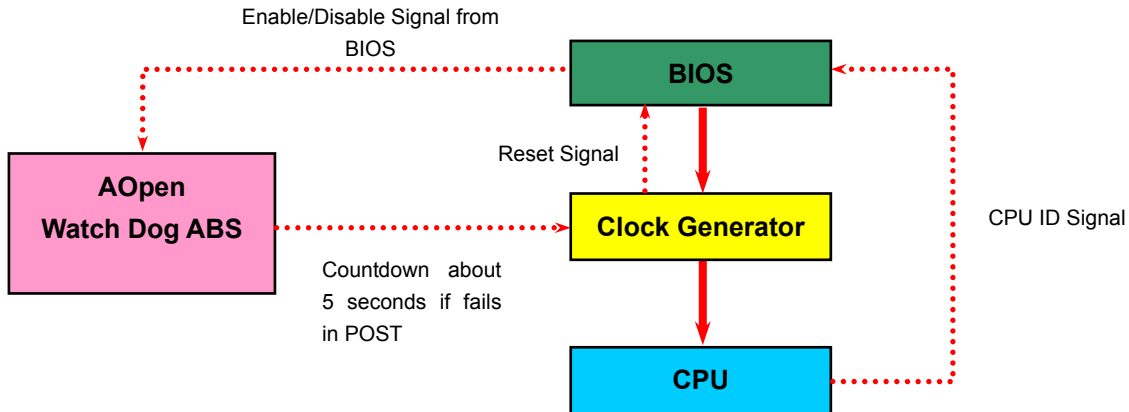

Battery-less and Long Life Design

This Motherboard implements a [Flash ROM](#) and a special circuit that provide you no batter power consumption of current CPU and CMOS Setup configurations. The RTC (real time clock) can also keep running as long as the power cord is plugged. If you lose your CMOS data by accident, you can just reload the CMOS configurations from Flash ROM and the system will recover as usual.

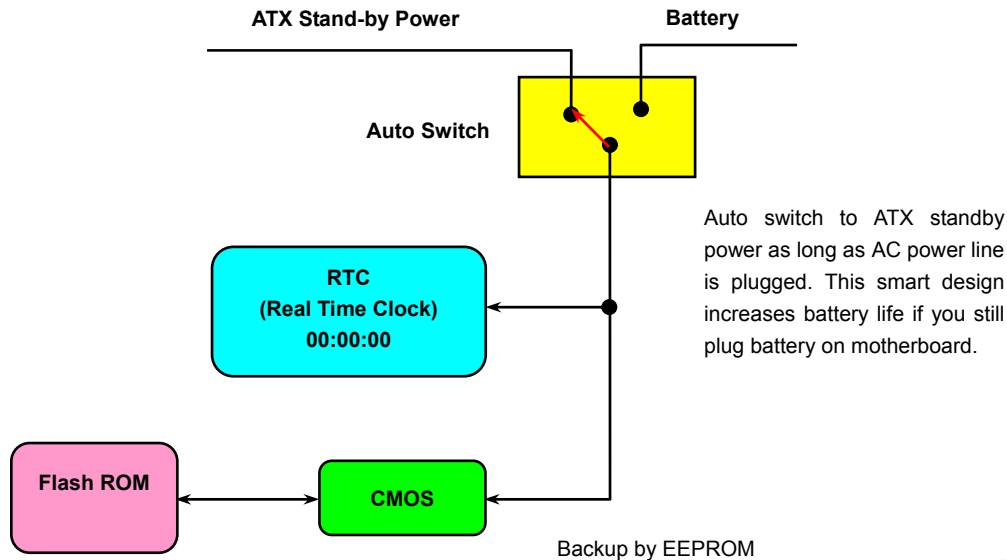

Setting CPU Frequency

BIOS Setup > Frequency/Voltage Control > CPU Bus Frequency

This motherboard is CPU jumper-less design, you can set CPU frequency through the BIOS setup, and no jumpers or switches are needed. The default setting is "table select mode". You can adjust the FSB from "CPU Bus Frequency" for overclocking.

$$\text{Core Frequency} = \text{CPU FSB Clock} * \text{CPU Ratio}$$

$$\text{PCI Clock} = \text{CPU FSB Clock} / \text{Clock Ratio}$$

$$\text{AGP Clock} = \text{PCI Clock} * 2$$

CPU Ratio	8x,30x
CPU FSB (By BIOS table)	100~248MHz by 1MHz stepping

Northwood CPU	CPU Core Frequency	FSB Clock	System Bus	Ratio
Pentium 4 2.0G	2000MHz	100MHz	400MHz	20x
Pentium 4 2.2G	2200MHz	100MHz	400MHz	22x
Pentium 4 2.26G	2260MHz	133MHz	533MHz	17x
Pentium 4 2.4G	2400MHz	133MHz	533MHz	18x
Pentium 4 2.4G	2400MHz	200MHz	800MHz	12x
Pentium 4 2.53G	2530MHz	133MHz	533MHz	19x
Pentium 4 2.66G	2660MHz	133MHz	533MHz	20x
Pentium 4 2.80G	2800MHz	133MHz	533MHz	21x
Pentium 4 2.80G	2800MHz	200MHz	800MHz	14x
Pentium 4 3.00G	3000MHz	200MHz	800MHz	15x
Pentium 4 3.06G	3060MHz	133MHz	533MHz	23x
Pentium 4 3.20G	3200MHz	200MHz	800MHz	16x

Willamette CPU	CPU Core Frequency	FSB Clock	System Bus	Ratio
Pentium 4 1.7G	1700MHz	100MHz	400MHz	17x
Pentium 4 1.8G	1800MHz	100MHz	400MHz	18x
Pentium 4 1.9G	1900MHz	100MHz	400MHz	19x
Pentium 4 2.0G	2000MHz	100MHz	400MHz	20x

Celeron CPU	CPU Core Frequency	FSB Clock	System Bus	Ratio
Celeron 2.2G	2200MHz	100MHz	400MHz	22x
Celeron 2.4G	2400MHz	100MHz	400MHz	24x

Warning: SIS 648FX chipset supports maximum 400MHz/533MHz/800MHz system bus and 66MHz AGP clock; higher clock setting may cause serious system damage.

Note: Since the latest processor, Northwood, would detect the clock ratio automatically, you may not be able to adjust the clock ratio in BIOS manually.



CPU and System Fan Connector (with H/W Monitoring)

Plug in the CPU fan cable to the 3-pin **CPUFAN1** connector. If you have chassis fan, you can also plug it on **SYSFAN2** or **SYSFAN3** connector.

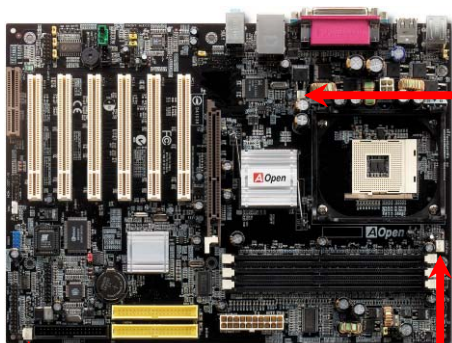

SYSFAN2 Connector



CPUFAN1 Connector

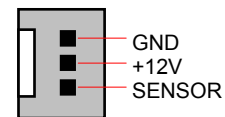

SYSFAN3 Connector

Note: Some CPU fans do not have sensor pin, so that they cannot support hardware monitoring function.

DIMM Sockets

This motherboard has three 184-pin DDR DIMM sockets that allow you to install DDR400/333/266 memory up to 3GB. Please note when you wish to use DDR400 RAM which requires higher voltage, you should set RAM voltage in 2.65 or higher by JP 29. The RAM voltage for JP 29 to adjust is from 2.55V-2.70V. Moreover, you can not run all three RAM in slots at the same time when run in DDR 400.

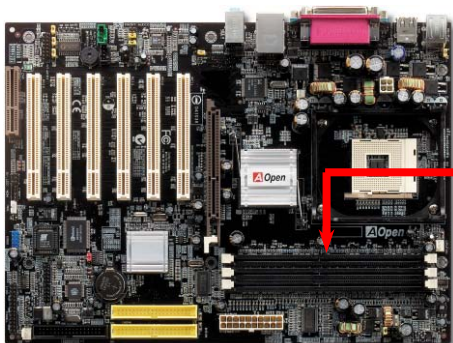

DIMM1
DIMM2
DIMM3

Warning: Due to the limitation of SiS648FX/SiS963 Chipset itself, this motherboard does not support DDR 266 when run in FSB 800. Otherwise, serious damage will happen to your motherboard and RAM.

Note: According to our technical test reports, this motherboard support almost all DDR 266/333/400 RAM in market. However, we strongly recommend you to visit our <http://www.aopen.com/tech/report/default.htm> to get further information of compatibility before you install RAM in your system.

How to Install Memory Modules

Please follow the procedure as shown below to finish memory installation.

1. Make sure the DIMM module's pin face down and match the socket's size as depicted below.

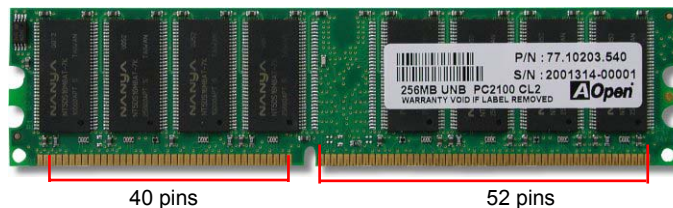

2. Insert the module straight down to the DIMM slot with both hands and press down firmly until the DIMM module is securely in place.

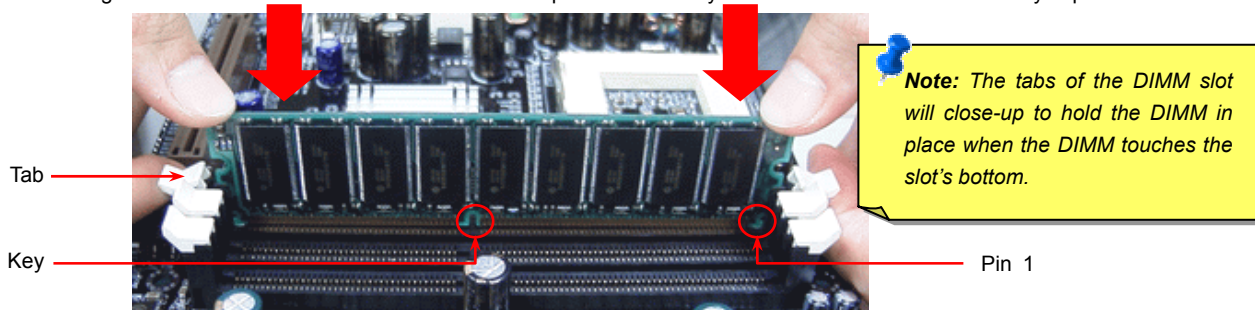

3. Repeat step 2 to finish additional DIMM modules installation.

Note: These images are for example only; they may not be exactly the same as the motherboard you purchased.

Front Panel Connector

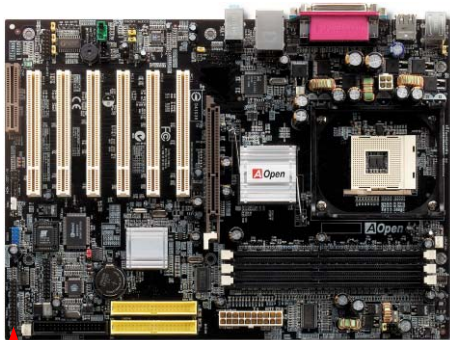

Pin 1

Attach the power LED, Keylock, speaker, power and reset switch connectors to the corresponding pins. If you enable "Suspend Mode" item in BIOS Setup, the ACPI & Power LED will keep flashing while the system is in suspend mode.

Locate the power switch cable from your ATX housing. It is 2-pin female connector from the housing front panel. Plug this connector to the soft-power switch connector marked **SPWR**.

Suspend Type	ACPI LED
Power on Suspend (S1) or Suspend to RAM (S3)	Flashing for every second
Suspend to Disk (S4)	The LED will be turned off

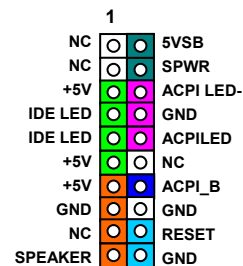
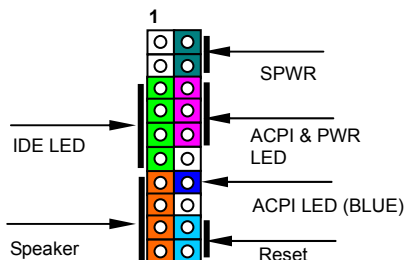

ATX Power Connector

This motherboard comes with a 20-pin and 4-pin ATX power connector. Make sure you plug in the right direction. We strongly recommend you to connect the 4-pin 12V ATX connector before connecting the 20-pin ATX power connector and use standard power supply specially designed for Pentium 4 system.

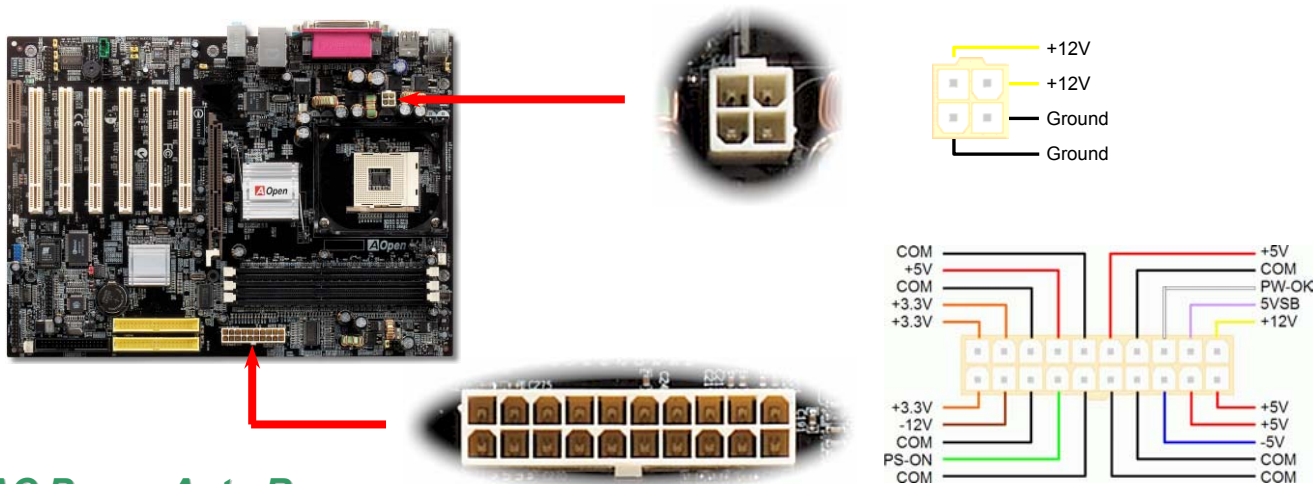

AC Power Auto Recovery

A traditional ATX system should remain at power off stage when AC power resumes from power failure. This design is inconvenient for a network server or workstation, without an UPS, that needs to keep power-on. This motherboard implements an AC Power Auto Recovery function to solve this problem.

IDE and Floppy Connector

Connect 34-pin floppy cable and 40-pin IDE cable to floppy connector FDD and IDE connector. Be careful of the pin1 orientation. Wrong orientation may cause system damage.

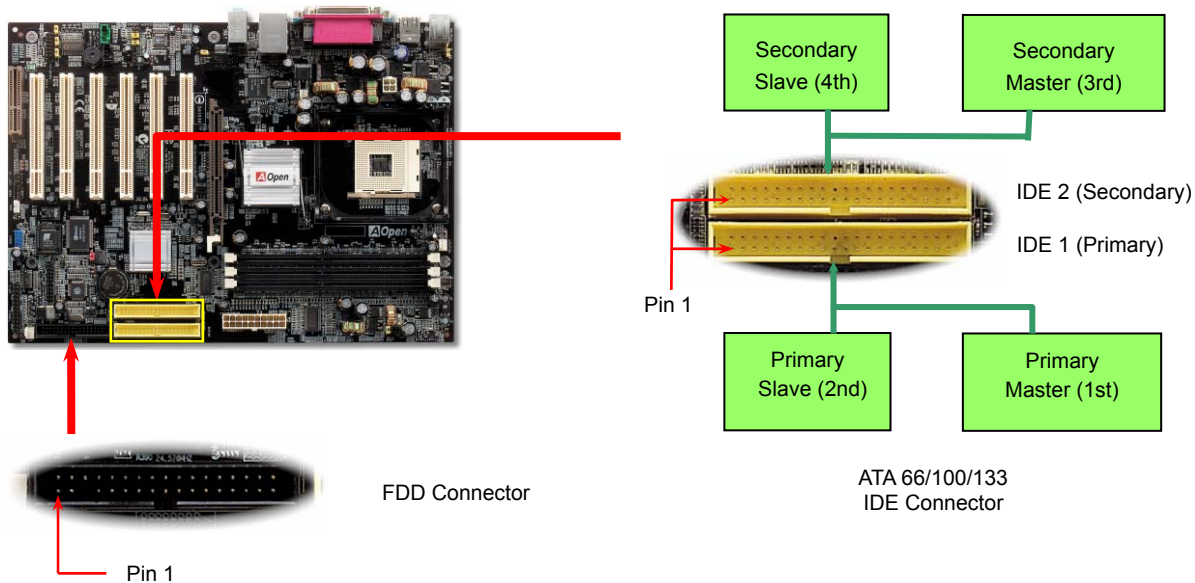

IDE1 is also known as the primary channel and IDE2 as the secondary channel. Each channel supports two IDE devices that make a total of four devices. In order to work together, the two devices on each channel must be set differently to **Master** and **Slave** mode. Either one can be the hard disk or the CDROM. The setting as master or slave mode depends on the jumper on your IDE device, so please refer to your hard disk and CDROM manual accordingly.

**Tip:**

1. For better signal quality, it is recommended to set the far end side device to master mode and follow the suggested sequence to install your new device. Please refer to above diagram
2. To achieve the best performance of Ultra **DMA 66/100/133** hard disks, a special **80-wires IDE cable** for Ultra **DMA 66/100/133** is required.

**Warning:** The specification of the IDE cable is a maximum of 46cm (18 inches); make sure your cable does not exceed this length.

ATA/133 Supported

This motherboard supports [ATA66](#), [ATA100](#) or [ATA133](#) IDE devices. Following table lists the transfer rate of IDE PIO and DMA modes. The IDE bus is 16-bit, which means every transfer is two bytes. As the hard drive industry introduces faster and higher capacity hard drives, the current Ultra ATA/100 interface causes a data bottleneck between the drive and the host computer. To avoid this problem, hard disk manufactures have introduced the new Ultra ATA-133 interface technology. Compared to traditional ATA/100, ATA/133 has up to 33 percent increase in interface speed with transfer rate of 133MB/s. ATA/133 performance is ideal for new operating systems, such as Window XP, that demand more storage space and faster data transfer rates from more responsive computing experiences.

To make good use of this new technology and enjoy its best performance, we recommend you to pair your system with a hard disk equipped with ATA/133 technology so that your system's need for speed on this motherboard can be satisfied.

Mode	Clock Period	Clock Count	Cycle Time	Data Transfer Rate
PIO mode 0	30ns	20	600ns	$(1/600\text{ns}) \times 2\text{byte} = 3.3\text{MB/s}$
PIO mode 1	30ns	13	383ns	$(1/383\text{ns}) \times 2\text{byte} = 5.2\text{MB/s}$
PIO mode 2	30ns	8	240ns	$(1/240\text{ns}) \times 2\text{byte} = 8.3\text{MB/s}$
PIO mode 3	30ns	6	180ns	$(1/180\text{ns}) \times 2\text{byte} = 11.1\text{MB/s}$
PIO mode 4	30ns	4	120ns	$(1/120\text{ns}) \times 2\text{byte} = 16.6\text{MB/s}$
DMA mode 0	30ns	16	480ns	$(1/480\text{ns}) \times 2\text{byte} = 4.16\text{MB/s}$
DMA mode 1	30ns	5	150ns	$(1/150\text{ns}) \times 2\text{byte} = 13.3\text{MB/s}$
DMA mode 2	30ns	4	120ns	$(1/120\text{ns}) \times 2\text{byte} = 16.6\text{MB/s}$
ATA 66	30ns	2	60ns	$(1/60\text{ns}) \times 2\text{byte} \times 2 = 66\text{MB/s}$
ATA 100	20ns	2	40ns	$(1/40\text{ns}) \times 2\text{byte} \times 2 = 100\text{MB/s}$
ATA 133	15ns	2	30ns	$(1/30\text{ns}) \times 2\text{byte} \times 2 = 133\text{MB/s}$

IrDA Connector

The IrDA connector can be configured to support wireless infrared module, with this module and application software such as Laplink or Windows 98 Direct Cable Connection, the user can transfer files to or from laptops, notebooks, PDA devices and printers. This connector supports HPSIR (115.2Kbps, 2 meters) and ASK-IR (56Kbps).

Install the infrared module onto the **IrDA** connector and enable the infrared function from BIOS Setup, UART Mode, make sure to have the correct orientation when you plug in the IrDA connector.

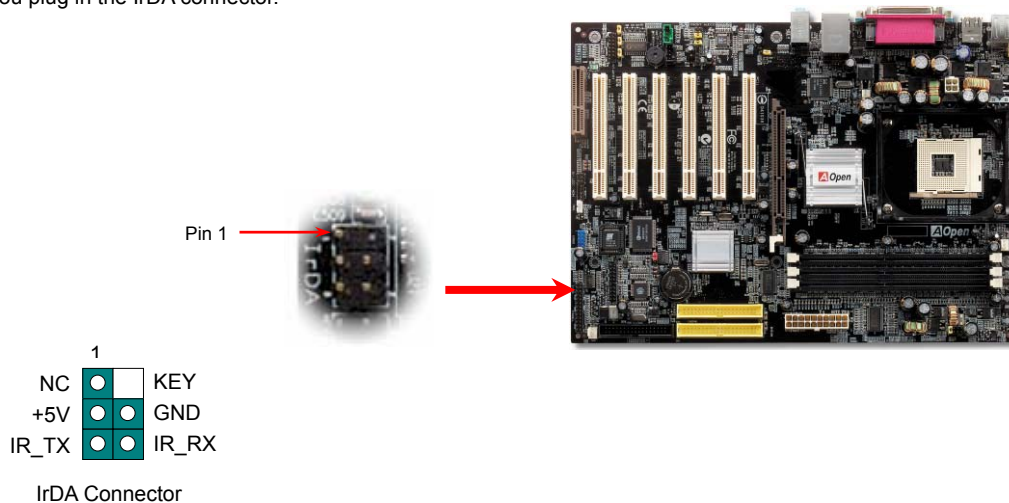

Support AGP 8X (Accelerated Graphic Port) Expansion Slot



AX45F-1394 provides an [AGP](#) 8x slot which is the latest AGP specification. The AGP 8x calls for the bus to operate at the basic AGP 66-MHz clock frequency and the bandwidth are 2.1Gbytes/s. It is a great improvement on the performance of 3D graphic. AGP supports only memory read/write operation and single-master single-slave one-to-one only. AGP uses both rising and falling edge of the 66MHz clock, for 2X AGP, the data transfer rate is $66\text{MHz} \times 4\text{bytes} \times 2 = 528\text{MB/s}$ and AGP 4x mode, $66\text{MHz} \times 4\text{bytes} \times 4 = 1056\text{MB/s}$. Now the transfer rate is $66\text{MHz} \times 4\text{bytes} \times 8 = 2112\text{MB/s}$.

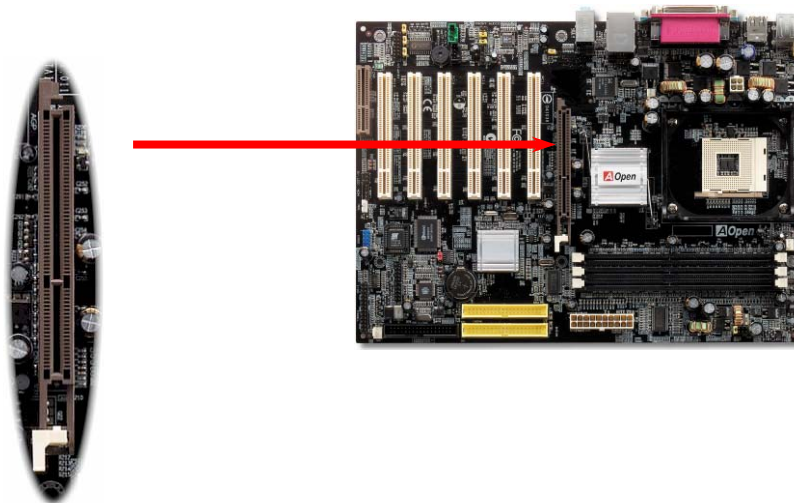

AGP Protection Technology and AGP LED

With the outstanding R&D ability of AOpen and its specially developed circuit, this model implements a blend new technology to protect your motherboard from being damaged by over-voltaging of AGP card. When AGP Protection Technology is implemented, this motherboard will automatically detect the voltage of AGP card and prevent your chipsets from being burnt out. Please note that if you install a AGP card with 3.3V, which is not supported by SIS648FX, the AGP LED on the motherboard will light up to warn you the possible damage of the exceeding voltage. You may contact your AGP card vendor for further support.

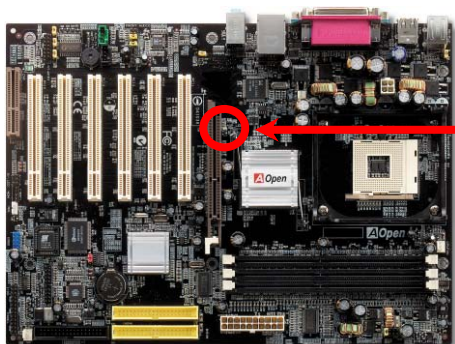

Warning: It is strongly recommended not to install a 3.3V AGP card, which is not supported by SIS648FX. When you do so, the AGP LED on the motherboard will light up to warn you the possible damage.

WOM (Zero Voltage Wake on Modem) Connector

This motherboard implements special circuit to support Wake On Modem; both Internal modem card and external box modem are supported. Since Internal modem card consumes no power when system power is off, it is recommended to use an internal modem. To use internal modem, connect 4-pin cable from RING connector of modem card to WOM connector on the motherboard.

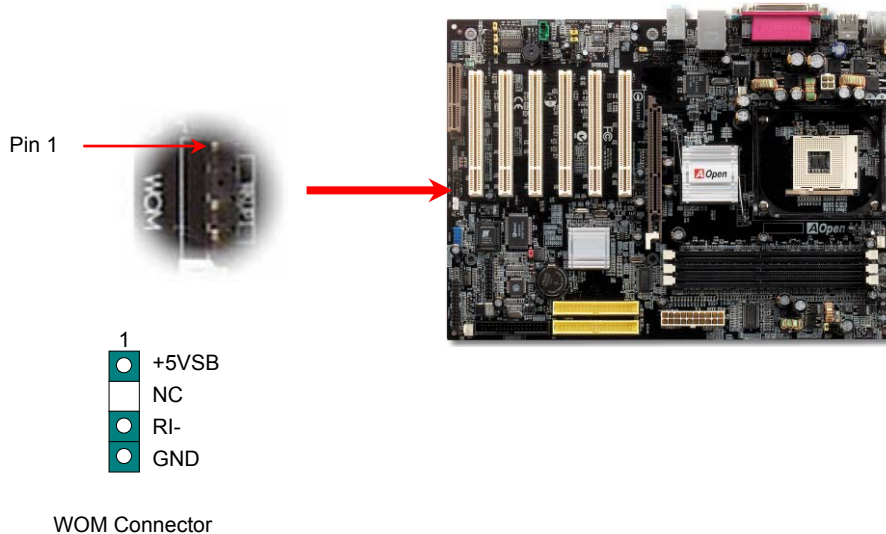

WOM by External BOX Modem

Traditional Green PC suspend mode does not really turn off the system power supply, it uses external box modem to trigger MB COM port and resume back to active.

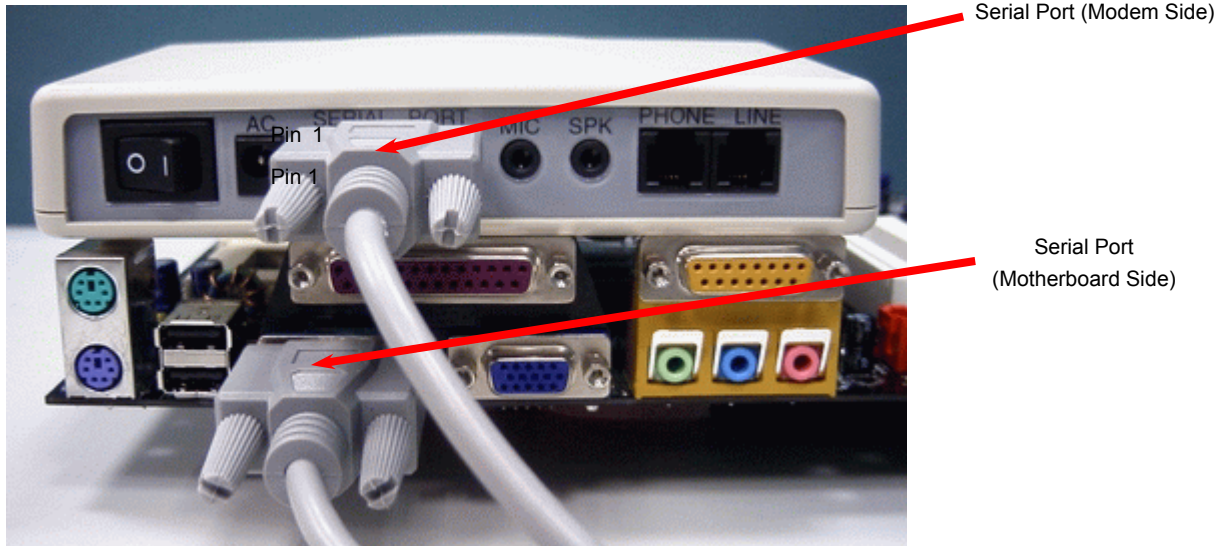

Note: This picture is for example only; it may not look exactly the same as the motherboard you purchased.

WOM by Internal Modem Card

With the help of the ATX soft power On/Off, it is possible to have a system totally power off, and wakeup to automatically answer a phone call as an answering machine or to send/receive a fax. You may identify whether or not your system is in true power off mode by checking to see if the fan of your power supply is off. Both an external box modem and an internal modem card can be used to support Modem Wake Up, but if you use an external modem, you have to leave your box modem on.

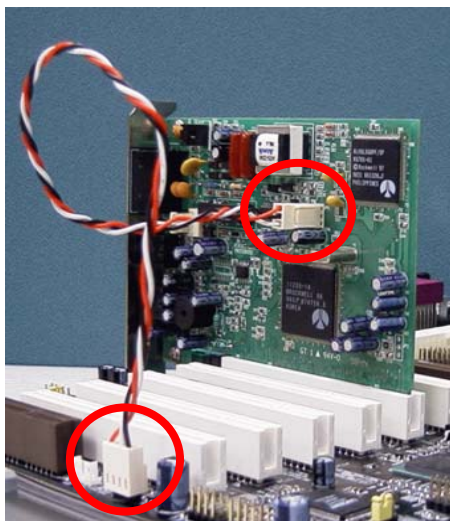

Note: This picture is for example only; it may not look exactly the same as the motherboard you purchased.

WOL (Wake on LAN) Connector

To use Wake On LAN function, you must have a network card with chipset that supports this feature, and connect a cable from LAN card to motherboard WOL connector. The system identification information (probably IP address) is stored on network card and because there is a lot of traffic on the Ethernet, you need to install network management software, such as ADM, for the checking of how to wake up the system. Note that, at least 600mA ATX standby current is required to support the LAN card for this function.

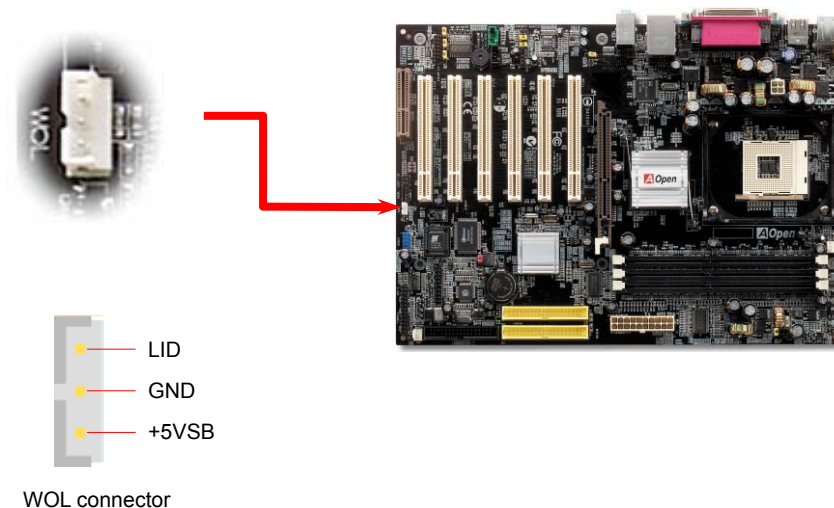

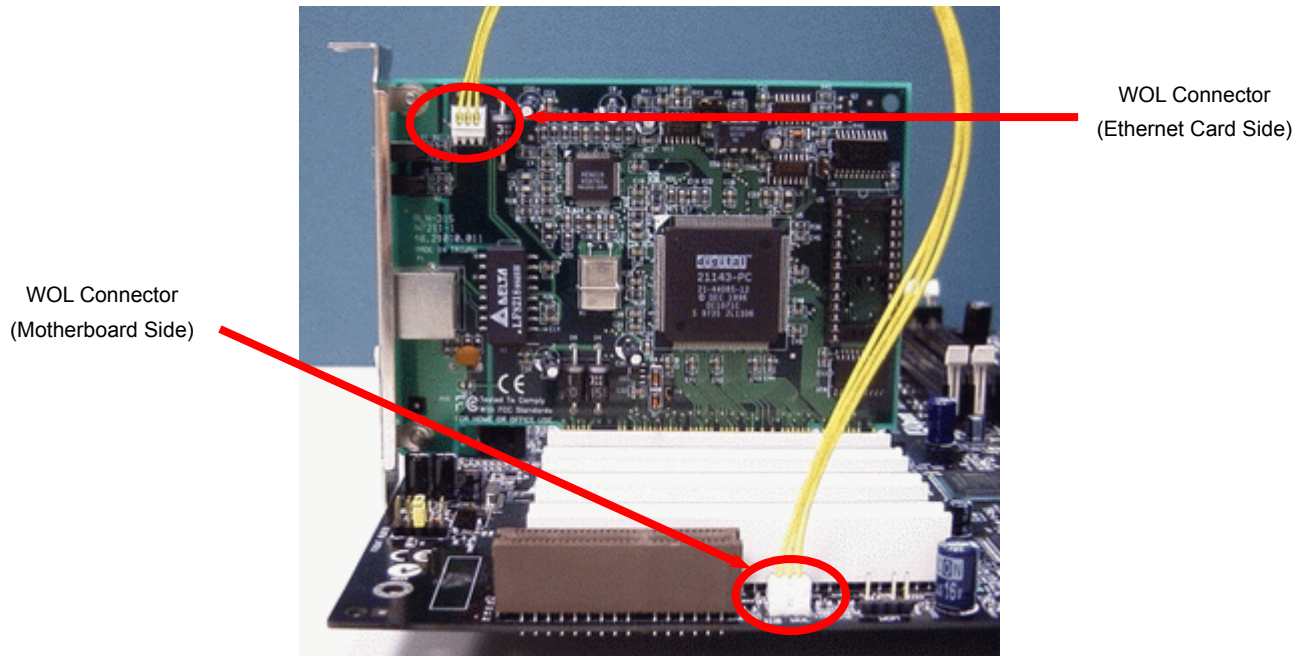

Note: This picture is for example only; it may not exactly look the same with the motherboard you purchased.

Support 10/100 Mbps LAN onboard

The South Bridge SIS963 includes a fast Ethernet controller on chip. On the strength of Realtek 8100BL LAN controller on board, which is a highly-integrated Platform LAN Connect device, it provides 10/100M bps Ethernet for office and home use, the Ethernet RJ45 connector is located on top of USB connectors. The orange LED indicates the link mode, it lights when linking to network and blinking when transferring data. The green LED indicates the transfer mode and it lights when data is transferring in 100Mbps mode. To enable or disable this function, you may simply adjust it through BIOS. To enable LAN wakeup function, you have to set the “Wake on PCI Card” enable in the BIOS “Power Management Setup” section.

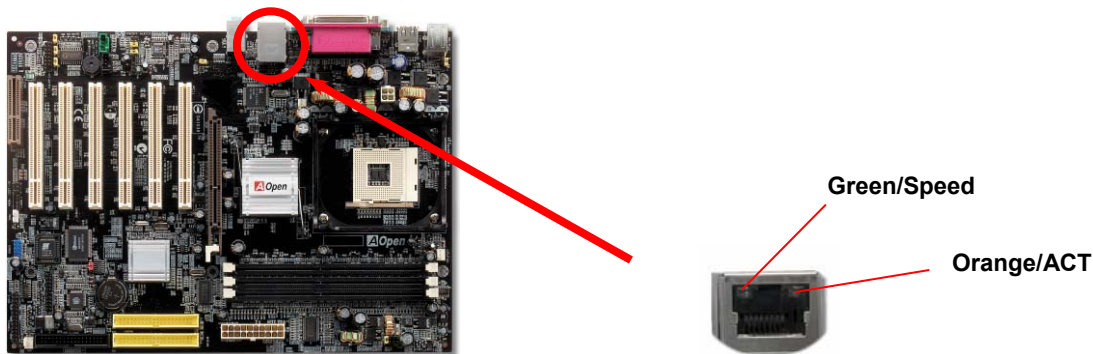

CNR (Communication and Network Riser) Expansion Slot

[CNR](#) is a riser card specification to replace the [AMR \(Audio/Modem Riser\)](#) that supports V.90 analog modem, multi-channel audio, and phone-line based networking. Owing to CPU computing power getting stronger, the digital processing job can be implemented in main chipset and share CPU power. The analogy conversion (CODEC) circuit requires a different and separate circuit design, which is put on CNR card. This motherboard implements sound CODEC on board, but reserve CNR slot for the option of modem function. Note that you can still use PCI modem card.

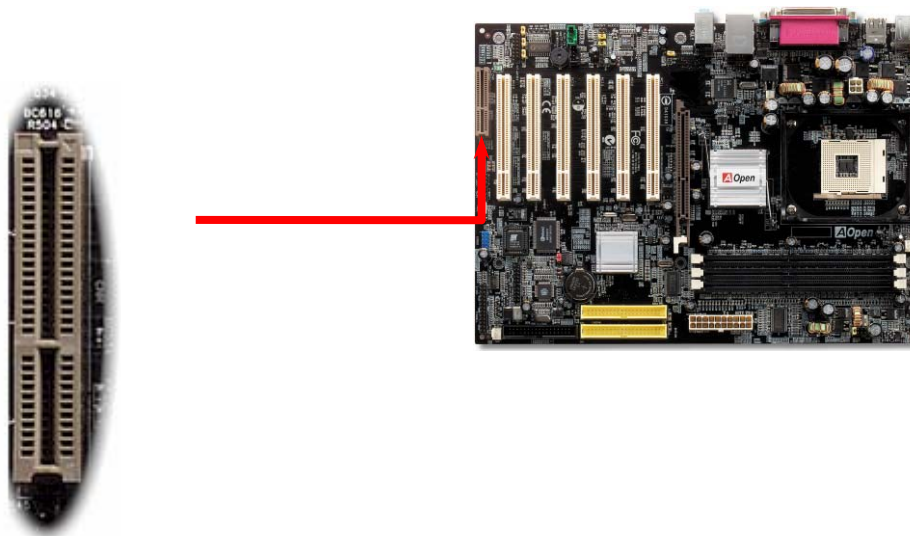

Support USB 2.0 Ports



This motherboard provides six [USB](#) ports to connect USB devices such as mouse, keyboard, modem, printer, etc. There are four connectors on the back panel and one header on board. You can use proper cables to connect USB devices from back panel or connect USB 2.0 header to the front panel of chassis.

Compared to traditional USB 1.0/1.1 with the speed of 12Mbps, USB 2.0 has a fancy speed up to 480 Mbps which is 40 times faster than the traditional one. Except for the speed increase, USB 2.0 supports old USB 1.0/1.1 software and peripherals, offering impressive and even better compatibility to customers. On this motherboard, all six ports support USB 2.0 function.

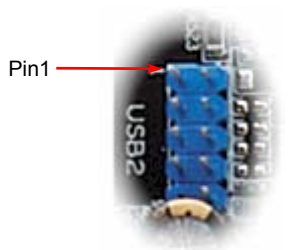

USB 2.0 Connector

	1		
+5V	●	●	+5V
SBD2-	●	●	SBD3-
SBD2+	●	●	SBD3+
GND	●	●	GND
KEY	□	●	NC

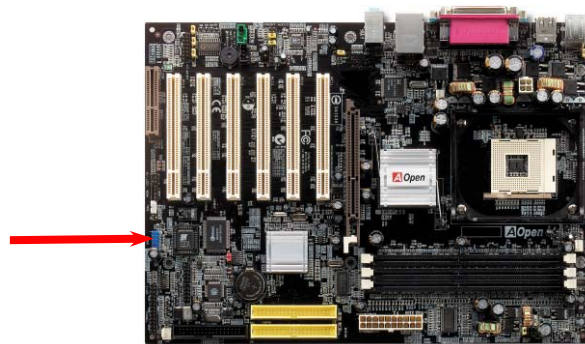

IEEE 1394 Connectors



With [IEEE1394](#) MAC Embedded in SiS 963 (with AGERE FW803), the IEEE 1394 provides data transfer rate up to 400Mb/s, and USB 1.0/1.1 just has 12Mbps. Hence, the IEEE 1394 interface can connect with the devices that need high data transferring performance, such as digital camera, scanner or others IEEE 1394 devices. Please use the proper cable to connect with devices.

	10	9	
SHIED GND			
+12V (Fused)			+12V (Fused)
TPB-			TPB+
GND			GND
TPA-			TPA+
	2	1	

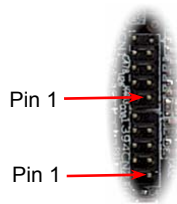

IEEE 1394
Port 1 & 2

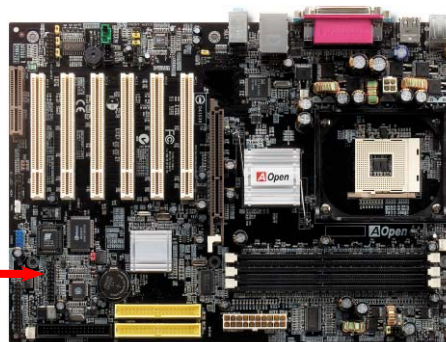

Warning: Please be noted that Hot-Plug in is not allowed on IEEE 1394 header, because it will burn the IC of the controller and damage the motherboard.

Colored Back Panel

The onboard I/O devices are PS/2 Keyboard, PS/2 Mouse, RJ-45 LAN Connector, COM1 and COM2, Printer, USB, and AC97 sound. The view angle of the drawing shown here is from the back panel of the housing.

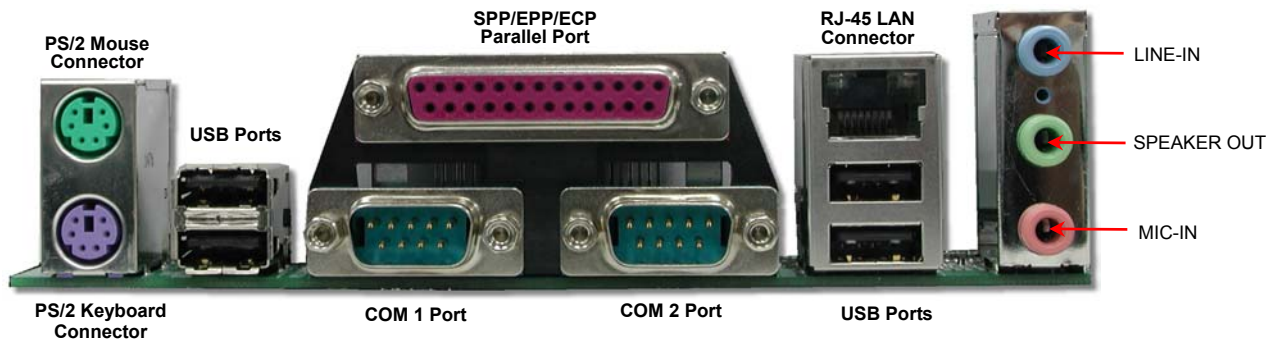

PS/2 Keyboard:	For standard keyboard, which use PS/2 plug.
PS/2 Mouse:	For PC-Mouse, which use PS/2 plug.
USB 2.0 Port:	Available for connecting USB1.1/2.0 devices.
Parallel Port:	To connect with SPP/ECP/EPP printer.
COM1/COM2 Port:	To connect with pointing devices, modem or others serial devices.
RJ-45 LAN connector	To connect Ethernet for home or office use.
Speaker Out:	To External Speaker, Earphone or Amplifier.
Line-In:	Comes from the signal sources, such as CD/Tape player.
MIC-In:	From Microphone.



S/PDIF (Sony/Philips Digital Interface) Connector

S/PDIF (Sony/Philips Digital Interface) is a latest audio transfer file format that provides impressive quality through optical fiber and allows you to enjoy digital audio instead of analog. Normally there are two S/PDIF outputs as shown, one for RCA connector, the most common one used for consumer audio products, and the other for optical connector with a even better audio quality. Through a specific audio cable, you can connect the S/PDIF connector to a S/PDIF audio module bearing S/PDIF digital output. However, you must have a S/PDIF supported speaker with S/PDIF digital input to make the most of this function.

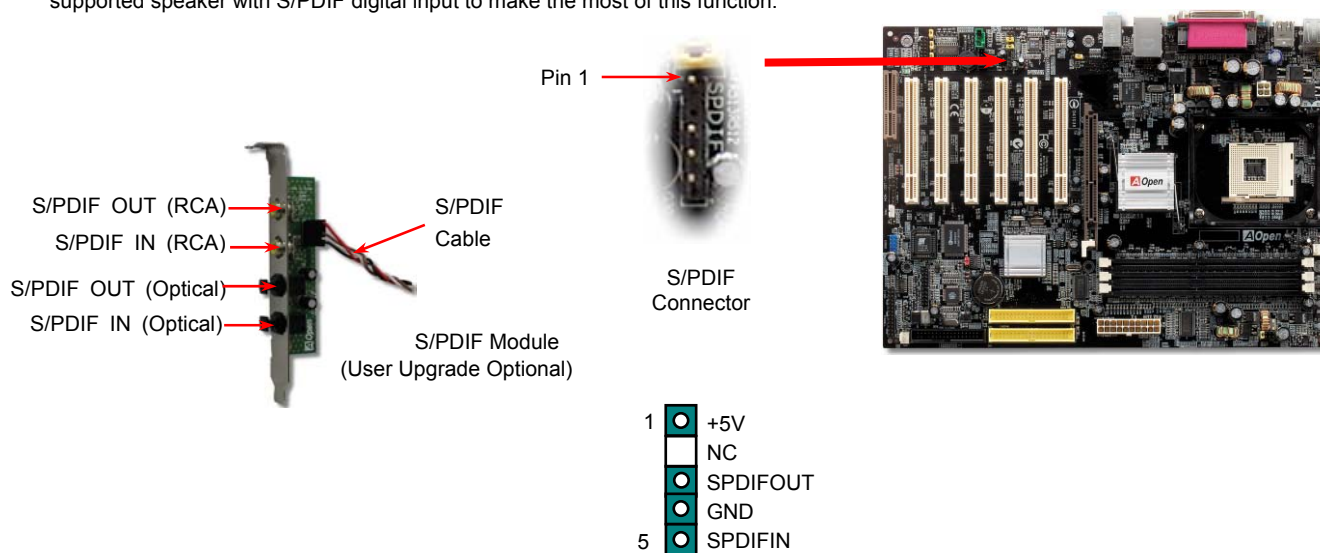

Super 5.1 Channel Audio Effect



This motherboard comes with an ALC650 Codec which supports high quality of 5.1 Channel audio effect, bringing you a brand new audio experience. On the strength of the innovative design of ALC650, you're able to use standard line-jacks for surround audio output without connecting any external module. To apply this function, you have to install the audio driver in the Bonus Pack CD as well as an audio application supporting 5.1 Channel. Picture below represents the standard location of all speakers in 5.1 Channel sound track. Please connect the plug of your front speakers to the green "Speaker out" port, rear speakers' plug to the blue "Line in" port and both of the center and subwoofer speakers to the red "MIC in" port.

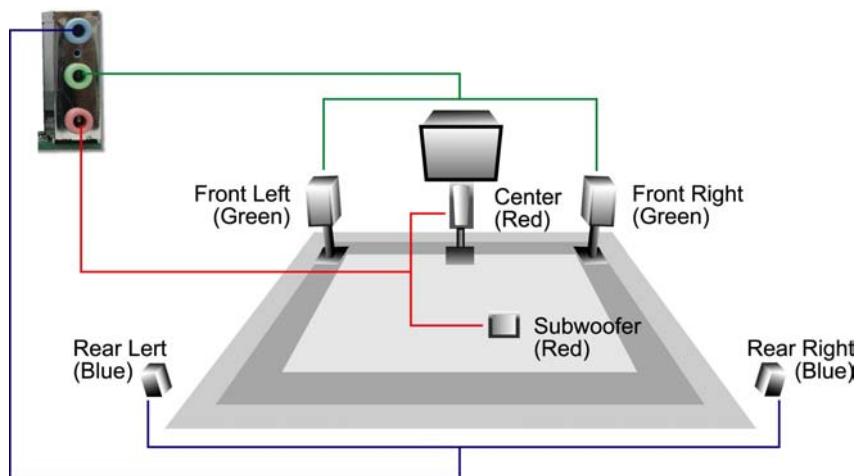

Front Audio Connector

If the housing has been designed with an audio port on the front panel, you'll be able to connect onboard audio to front panel through this connector. By the way, please remove the jumper cap from the Front Audio Connector before you connect the cable. Do not remove this yellow jumper cap if your housing doesn't have an audio port on the front panel.

	1		
FP_MIC			GND
FP_VREF			+5V
PHONE_R			JS1
NC			NC
PHONE_L			NC

Front Audio Connector

Pin 1

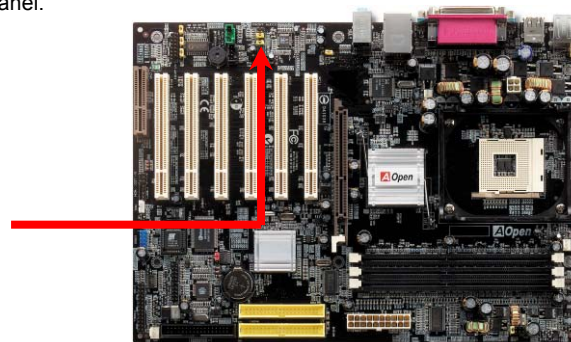
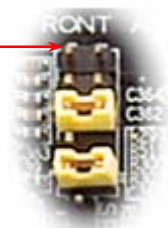

Note: Please remove the jumper cap from the front audio connector before you connect the cable. Do not remove this yellow jumper cap if your housing doesn't have an audio port on the front panel.

Dr. LED Connector (User Upgrade Optional)

Connecting Dr. LED you can easily find the system problems that may occur while assembling. It can clearly indicate whether the problem is caused from components or improper installation through the 8 LED lights of Dr. LED on the front panel. That is to say you can diagnose your system status quickly.

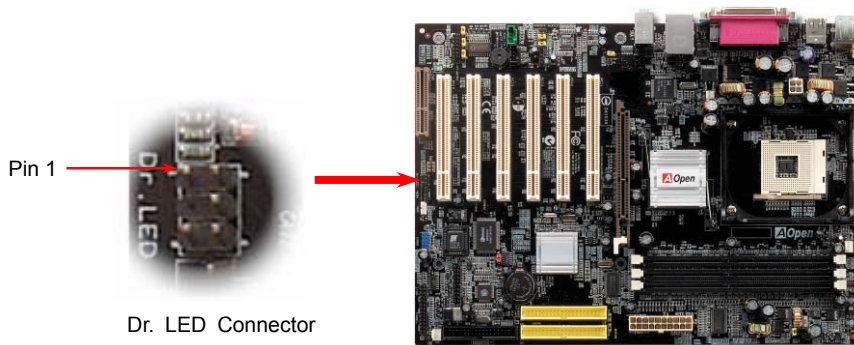

Dr. LED Connector

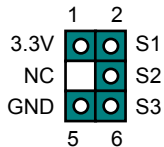

Dr. LED is a CD disc storage box with 8 LEDs on its front panel, the size of Dr. LED is exactly the same as 5.25 in floppy drive, so that it can be mount into normal 5.25 in drive bay of any housing.

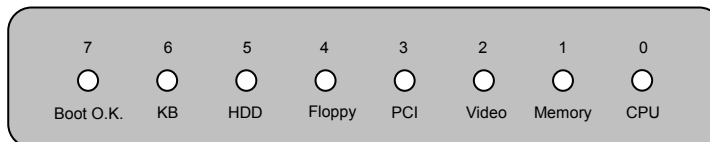

The total 8 LEDs light up alternatively if the system fails in one of eight stages. Once the LED7 (latest LED) is lit, this indicates that the system has completed its boot-up procedure.

The 8 LEDs indicate the following messages when lit:

LED 0 - Indicates that the CPU may have been installed incorrectly or is damaged.

LED 1 - Indicates that the memory may have been installed incorrectly or is damaged.

LED 2 - Indicates that the AGP may have been installed incorrectly or is damaged.

LED 3 - Indicates that the PCI card may have been installed incorrectly or is damaged.

LED 4 - Indicates that the floppy disk drive may have been installed incorrectly or is damaged.

LED 5 - Indicates that the HDD may have been installed incorrectly or is damaged.

LED 6 - Indicates that the keyboard may have been installed incorrectly or is damaged.

LED 7 - Indicates that the system is OK.

Note: During POST (Power On Self Test) procedure, the Debug LED will light on sequentially from LED0 to LED7 until the system boot O.K

Case Open Connector

The "CASE OPEN" header provides chassis intrusion-monitoring function. To make this function works, you have to enable it in the system BIOS, connect this header to a sensor somewhere on the chassis. So, whenever the sensor is triggered by lights or by the opening of the chassis, the system will beep to inform you. Please be informed that this useful function only applies to advanced chassis, you may purchase an extra sensor, attach it on your chassis, and make a good use of this function.

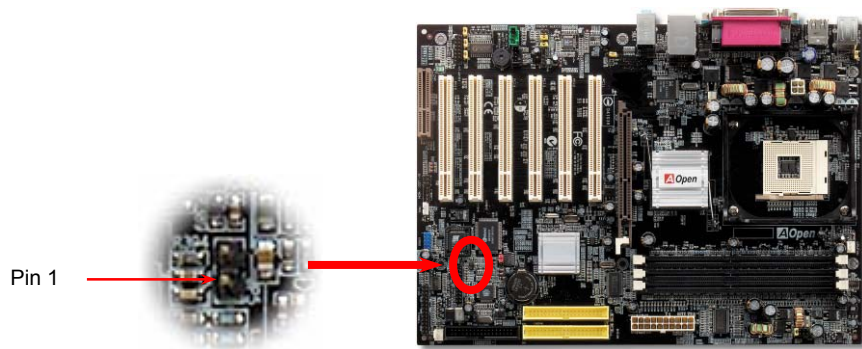

- GND
- Sensor

1

CD Audio Connector

This connector is used to connect CD Audio cable from CDRom or DVD drive to onboard sound.

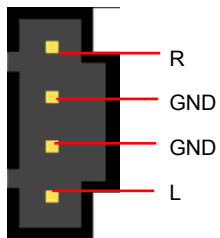
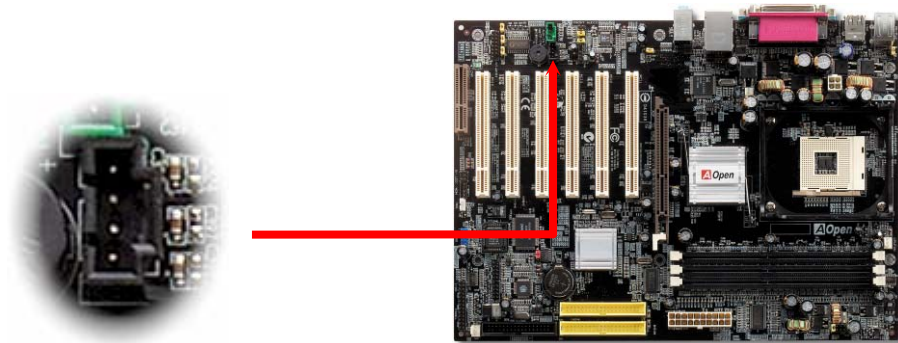

CD-IN Connector

AUX-IN Connector

This GREEN connector is used to connect MPEG Audio cable from MPEG card to onboard sound.

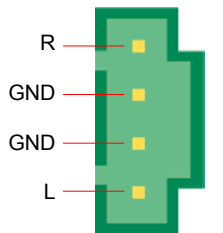

AUX-IN Connector

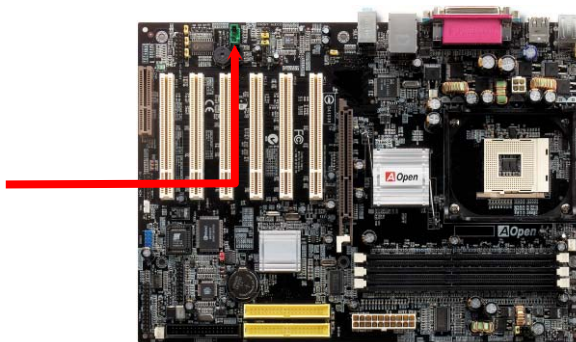

Game Port Bracket Supported

This motherboard comes with a game port (Joystick-Midi) for you to connect any midi devices or joysticks. To use this function you have to have a joystick module and connect it with a game port cable to this port on the motherboard.

Joystick Module
(User Upgrade Optional)



Pin1

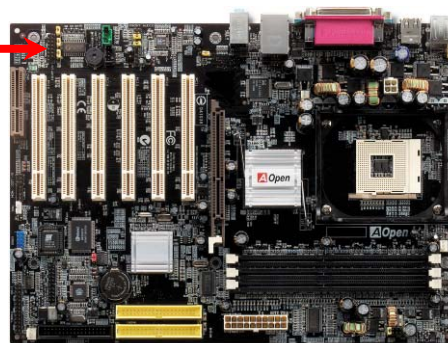

Game Port Connector

	1	
+5V	●	+5V
JAB1	●	JBB1
JACX	●	JBCX
GND	●	MIDI_TXD
GND	●	JBCY
JACY	●	JBB2
JAB2	●	MIDI_RXD
+5V	●	KEY

JP2 Speaker Output Jumper

This motherboard comes with another considerate option that allows you to turn off the voice from buzzer and speaker. You can choose not to be bothered by the warning made from Dr. Voice II when it detects any error in operating system. You may also set JP2 to choose sending out voices from buzzer or speaker.

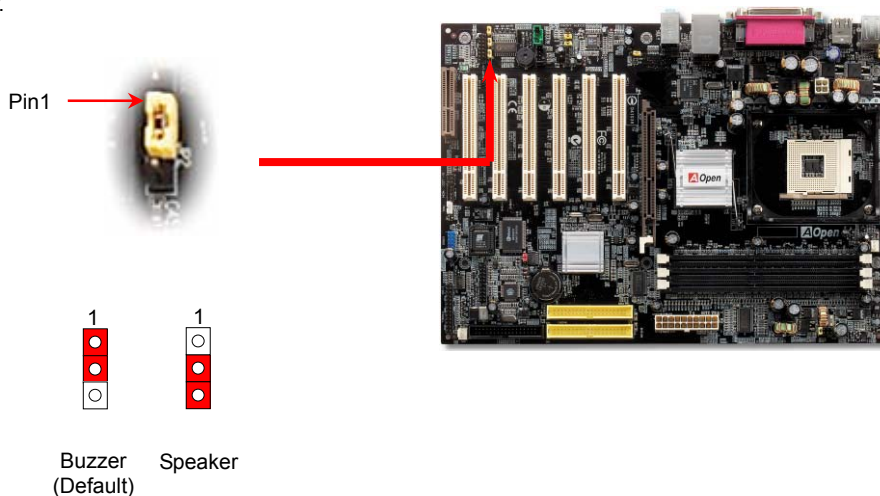

JP14 Clear CMOS Data

You can clear CMOS to restore system default setting. To clear CMOS, follow the procedure below.

1. Turn off the system and unplug the AC power.
2. Remove ATX power cable from connector PWR2.
3. Locate JP14 and short pins 2-3 for a few seconds.
4. Return JP14 to its normal setting by shorting pin 1 & pin 2.
5. Connect ATX power cable back to connector PWR2.

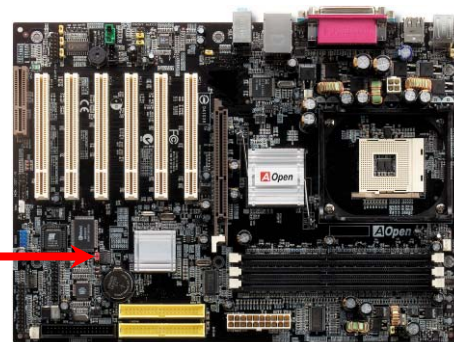
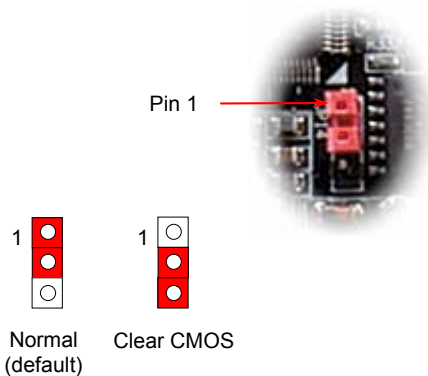

Tip: When should I Clear CMOS?

1. Boot fails because of overclocking...
2. Forget password...
3. Troubleshooting...

JP15/JP16 Dr. Voice II Language Select Jumpers

Dr. Voice is a great feature of AX45F-1394, which can identify the problems you may encounter in the operating system. It can clearly “**tell you**” whether the problem is caused from components or improper installation such as CPU, memory module, VGA, PCI add-on card, FDD, HDD or keyboard. Dr. Voice provides four language versions: **English, German, Japanese** and **Chinese**. You can select your preferred language by **JP15 & JP16** jumpers. Furthermore, you may also set JP2 to choose sending out voices from buzzer or speaker.

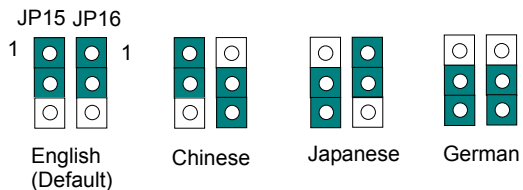
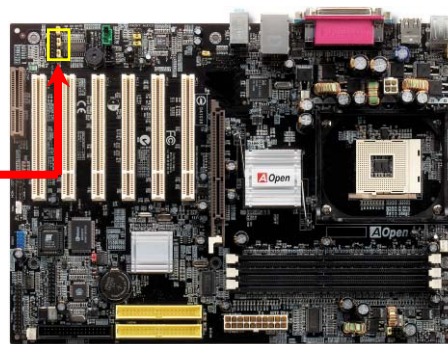
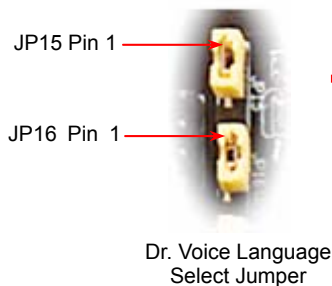

JP27 / JP28 Keyboard/Mouse Wake-up Jumper

This motherboard provides USB and PS2 keyboard / mouse wake-up function. You can use JP27 / JP28 to enable or disable the resuming of your system from suspend mode with any USB keyboard or mouse connected. JP28 controls 1st USB channel, and JP27 controls 2nd USB channel. The factory default setting is set to “Disable” (1-2), and you may enable this function by setting the jumper to 2-3. Please note that you have to enable USB, PS2 keyboard and PS2 mouse settings in the “Power Management Setup” section in BIOS before you use this function.

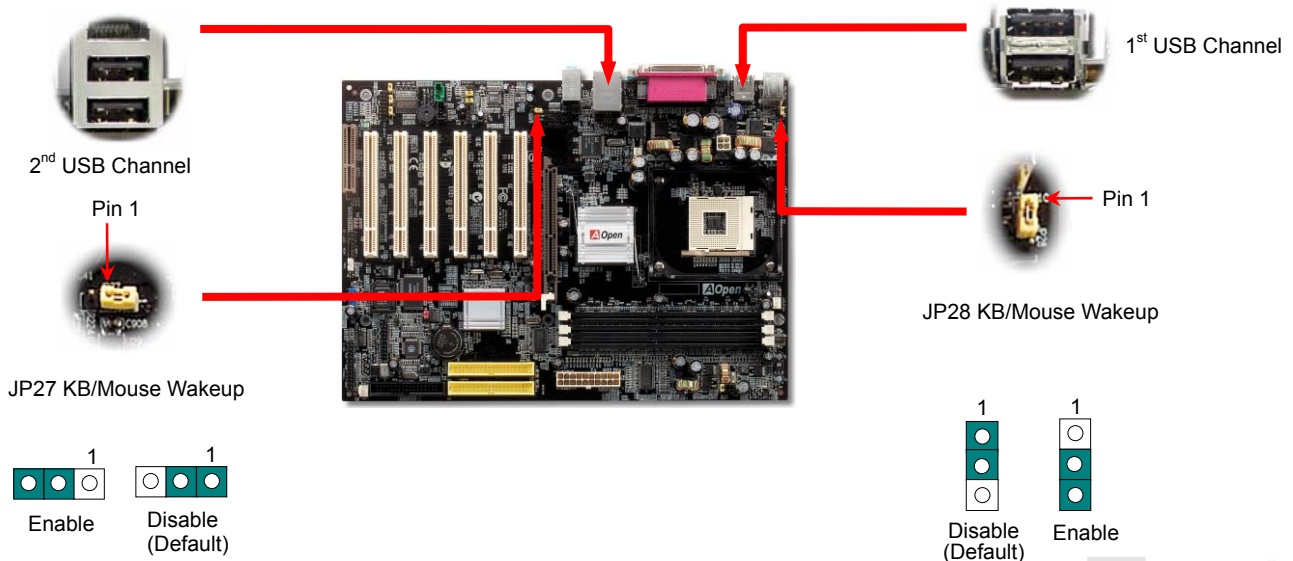

JP29 DDR Voltage Jumper

This motherboard supports all DDR266/333/400 DDR RAM in the market. And in order to get higher and more stable performance of memory, we provide JP29 to adjust the voltage of RAM from 2.55V to 2.70V. However, if you wish to use DDR400 RAM which requires higher voltage, you may have to adjust the jumper to set a suitable voltage supply from 2.65V to 2.70V.

DDR Voltage	JP29
2.55 V	1-2
2.60 V	3-4
2.65 V	5-6
2.70 V	7-8

JP29 DDR Voltage Jumper

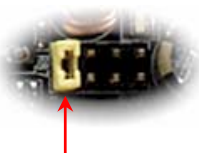

Pin 1

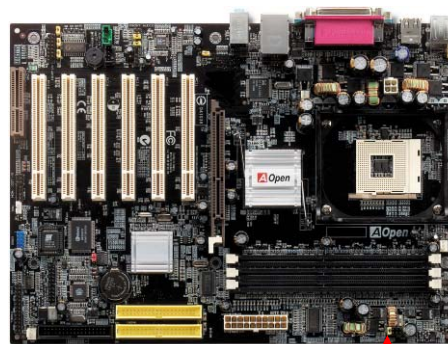

STBY LED

STBY LED is AOpen's considerate design that we aim at providing you friendly system information. The STBY LED will light up when power is provided to the motherboard. This is a convenient indication for you to check the system power status in many circumstances such as power on/off, stand-by mode and RAM power status during Suspend to RAM mode.

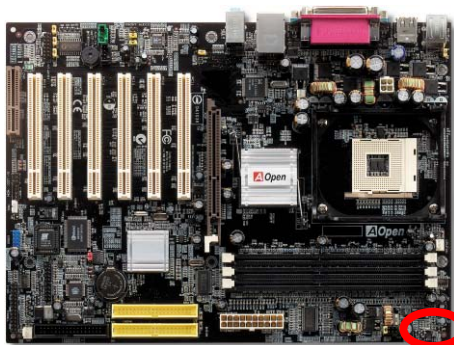

System
Power LED

Warning: Do not install or remove the DIMM module or others devices when the STBY LED lights on.

Enlarged Aluminum Heatsink

Cool down CPU and Chipset are important for system reliability. Enlarged aluminum heat sink provides better heat consumption especially when you are trying to over-clock the CPU.

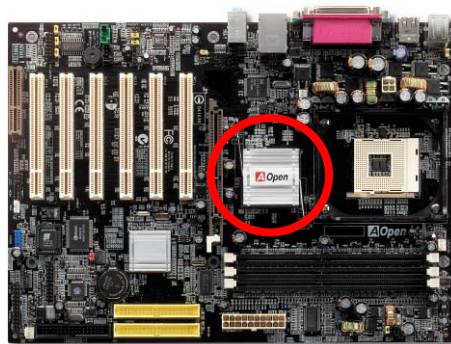

Resettable Fuse

Traditional motherboard uses fuses to prevent Keyboard and USB port from over-current or shortage. These fuses are soldered onboard that when it is broken (function to protect motherboard), user cannot replace them and result in malfunction of motherboard.

With expensive Resettable Fuse, the motherboard can be resumed back to normal function even after the fuse had done its protection job.



Resettable Fuse

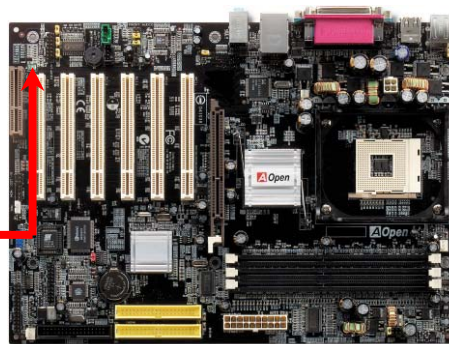

3300 μF Low ESR Capacitor

The quality of low ESR capacitor (Low Equivalent Series Resistance) during high frequency operation is very important for the stability of CPU power. The idea of where to put these capacitors is another know-how that requires experience and detail calculation.

Not only that, AX45F-1394 implements 3300 μF capacitors, which is much larger than normal capacitor (1000 & 1500 μF) and it provides better stability for CPU power.

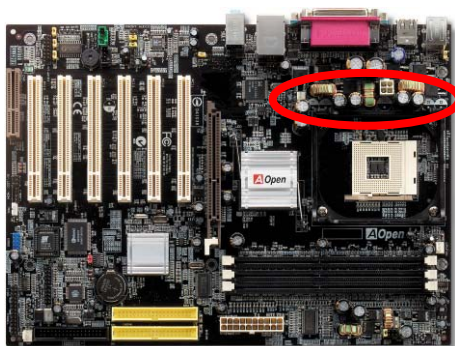

The power circuit of the CPU core voltage must be checked to ensure system stability for high speed CPUs (such as the Pentium IV, or when overclocking). A typical CPU core voltage is 2.0V, so a good design should control voltage between 1.860V and 2.140V. That is, the transient must be below 280mV. Below is a timing diagram captured by a Digital Storage Scope, it shows the voltage transient is only 143mV even when maximum 60A current is applied.

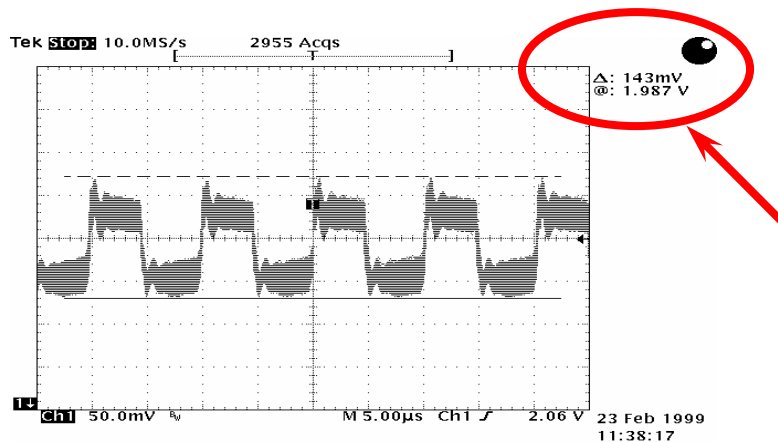

Note: This diagram for example only, it may not be exactly the same as the motherboard you purchased.

AOConfig Utility



AOConfig

AOOpen always dedicated to provide users a much friendly computer environment. We now bring you a comprehensive system detection utility. AOConfig is a Windows based utility with user-friendly interface that allows users to obtain information of the operation system and hardware such as motherboard, CPU, memory, PCI devices and IDE devices. The powerful utility also displays the version of BIOS and firmware for your convenience of maintenance.

Moreover, AOConfig allows users to save information in *.BMP or *.TXT format which users may collect the system information in detail and send them to AOOpen directly for technical support or for further diagnose of system problems.

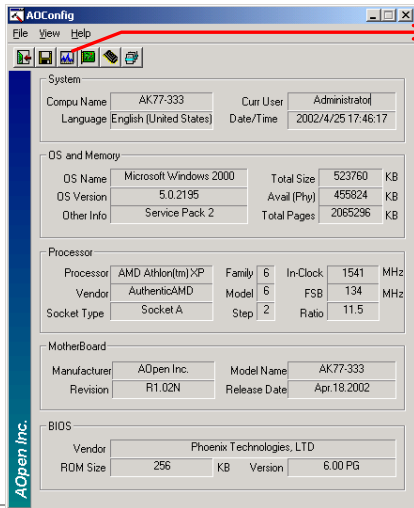

1. The system page shows the detailed information of the motherboard, operating system, processor, and BIOS version.

2. The PCI device page shows the configurations of all PCI devices installed in your motherboard.

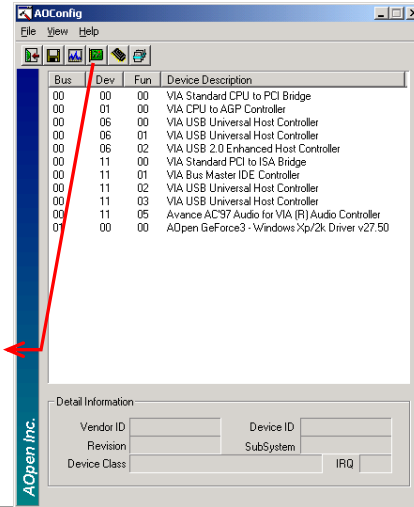

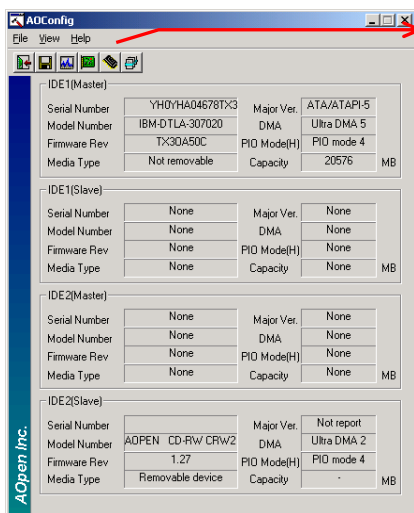

3. This page presents the IDE device information, such as serial number, manufacturer, firmware version, and capacity.

4. From this page, users can obtain the technical support information of AOpen. Moreover, detailed information could be saved in .bmp or .txt format.

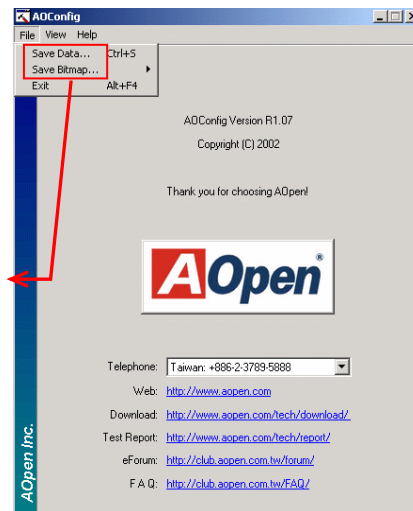

NOTE:
 ADOConfig can be used under Windows 98SE/ME, NT4.0/2000/XP. Please also note that ADOConfig can only be operated in a system equipped with an AOpen motherboard. Before running ADOConfig, all applications must be closed.



The noise is gone!! ---- SilentTek 



As the clock of CPU keeps rocketing higher and higher, it inevitably brings higher heat and system temperature in a relative way. The way we deal with this heat problem, however, is to spare no effort to add one fan after another to protect our pampered system, expecting these fans could cool down our machine as much as they could.

But at the same time, we believe that same users are affected terribly by the irritating noises of these fans while working with their PC. As a matter of fact, we do not have to get our fans running at such a high speed in most cases; on the contrary, we

Phoenix - AwardBIOS CMOS Setup Utility
Silent PC/PC Health Status

CPU Warning Temp.	60° C/140° F	
CPUFan1 Boot Speed	70% 3150 RPM	
SYSFan2 Boot Speed	70% 3500 RPM	
CPUFan1 OS Speed	100% 4500 RPM	
SYSFan2 OS Speed	100% 5000 RPM	
Fan Mode	Smart control	
x CPUFan1 Fixed Speed	100% 4500 RPM	
x SYSFan2 Fixed Speed	100% 5000 RPM	
CPU Set Temp.	40° C	
SYS Set Temp.	30° C	
CPU Kernel Temp.	69° C/156° F	
CPU Temp.	47° C/116° F	
SYS Temp.	31° C/107° F	
CPUFAN1 Speed	4500 RPM	
SYSFAN2 Speed	5000 RPM	
SYSFAN3 Speed	5532 RPM	
Vcore(V)	1.48 V	

Item Help

Menu Level ▶

This is fan control mode during POST and Open Jukebox, after exiting the Jukebox, the fan will be set to Fan OS Speed.

[Full Speed]
Run in full speed.

[Smart Control]
According to the safety temperature you set below, fan speed will be controlled as slow as possible.

↑↓←→:Move Enter:Select +/-/PU/PD:Value F10:Save ESC:Exit F1:General Help
F2:Item Help F5:Previous Values F6:Setup Defaults F7:Turbo Defaults

discovered that having your fans running at appropriate time and speed not only reduces the noise, but also consumes the least power the system needs, so as to prevent over-wasting of energy resource.

Today, AOpen Motherboard is honored to bring you a new overall solution, SilentTek, to make your system quiet. To collocate with hardware circuit, BIOS and the utility under Windows, SilentTek combined "Hardware-Status Monitoring", "Overheat Warning" and "Fan Speed Control" with user-friendly interfaces to provide you a perfect balance among noises, system performance and stability.



The first image you have here is the Voltage Status page. You can find current status of all voltages and set your expected margins of warning level.

In "Temp/Fan/Case" page, you may get aware of the current temperature of CPU and the heat inside chassis. Also, you can check if fans are running properly.

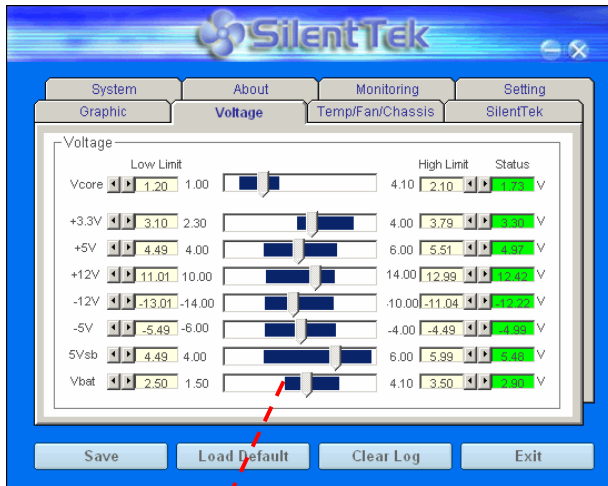

You may check your system voltage from the indicating bar here.

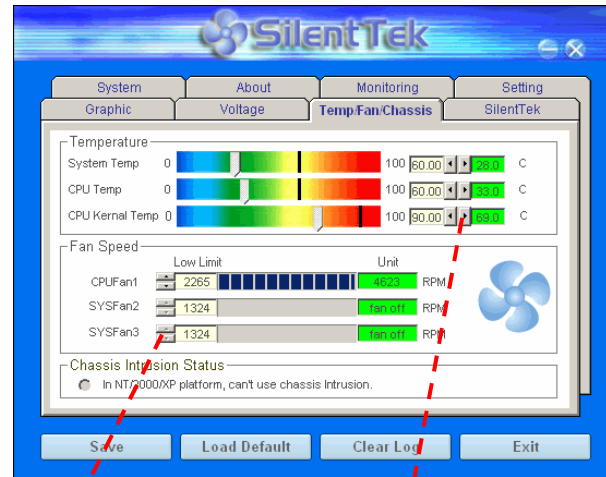

Of course, you may set your defaulted lowest margin for your fans and SilentTek would also pop up a message box to alarm you when the fan is rotating slower than this specified speed.

You may set the highest margin of your CPU and system temperature as default, and SilentTek would pop up a message box to alert you with alarm when the temperature goes beyond the specified margin.

The following page is surely the most important part of this utility. You may control the rotation speed of specific fans that you have got the options inside in this page.

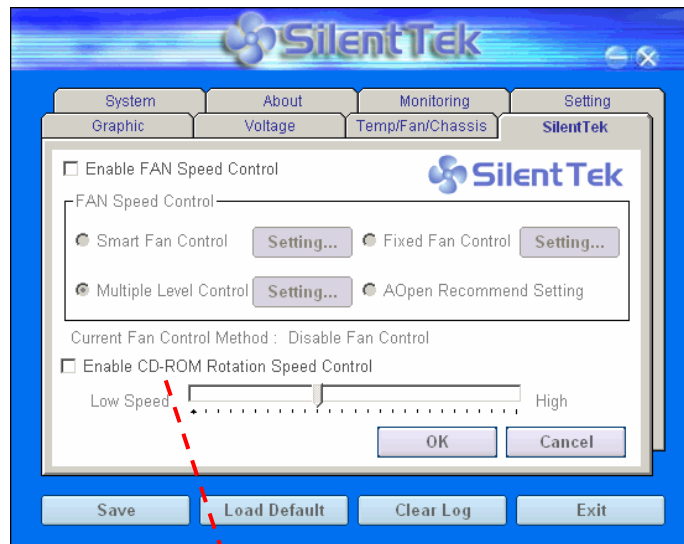

CD-ROM Rotation Speed Control: by enabling the CD-ROM Rotation Speed Control, you can adjust the rotation speed of your CD-ROM. When you set the speed to high level, the CD-ROM will work at its fastest speed and it will run at basic required speed while you set the value to low speed.

1. **Smart FAN Control:** This is the default setting of SilentTek and can be used for any branded computer housing. With a special algorithm developed by AOpen, the fan speed is automatically adjusted by the factors of CPU and ambient temperature. Ease-of-use and trouble free at your service.
2. **Fixed FAN Control:** Under this setting, a desired fan speed is set fixed when operating.
3. **Multiple Level Control:** This is the most versatile setting that allows you to set fan speed in relation to temperature. You may find that this setting fits you best.
4. **AOpen Recommend Setting:** This setting is designed specifically for AOpen housing. A series of lab tests were conducted under the real world scenario to determine optimum fan speed to reduce noise level within CPU working condition and temperature. Most of the time, the fan would remain still when CPU is not fully utilized.

Note: Due to hundreds different brands of fan on the market, inaccuracy may happen in some cases when you had your rotation speed adjusted. It is still under the criterion and please rest assured that it won't cause any problem to your system.

EzClock **NEW!**

Have you ever thought how great it would be if you can adjust the frequency setting on your motherboard under Windows environment and be a real master of your system? Everybody knows that the ratio and frequency setting are key factors to influence the system performance, however, it's absolutely not an easy task for an amateur to adjust the setting value. On most traditional motherboards, you have to get into BIOS screen for the frequency and reboot the system again and again. But from now on, you don't suffer the boring stuffs anymore.

With brand-new and user-friendly EzClock that AOpen specially designs for his users, you can adjust those important values as you please and think of suitable. This tailor-made EzClock allows you to set the voltage and frequency of CPU, VGA, PCI and memory under Windows environment as well as in BIOS setting page; even better, those settings will be displayed real-time. Having this handy EzClock, you can monitor the system when you're fine-tuning the performance of your system. It provides you detailed and necessary information. Now let's take a look how it works on utility, BIOS and POST.



AOpen

How You Adjust the Settings in EzClock Utility

In EzClock utility, you can adjust CPU Front Side Bus (FSB), the voltage and frequency of VGA, AGP, PCI and DRAM. Besides, the CPU related information such as CPU voltage, temperature and CPUFAN rotation speed will also be displayed on this utility.

CPU Color Bars:

The color bar will light on and show different colors as values change. On default values, it will show green.



On the left circle area shows Ratio, FSB and frequency information about CPU. When the values are set to factory default, the light on the top and bottom of the circle will show green and it will vary as you change these CPU settings.

CPU Ratio, FSB and frequency displaying area:

You can adjust CPU FSB here by entering preferred value.

On the right part of the panel is the section that you adjust the settings of VGA, AGP, PCI and memory. To adjust the voltage and clock frequency of those installments, you can press “-” or “+” on corresponding items. The color parts represent the situation of values. The higher value you set, the light on the color bar goes to right and turns red. After finishing those value settings, you can press “Apply” button on the upper right hand corner to save changes to CMOS.

VGA, AGP, PCI and DRAM Voltage / Clock Area:

Pressing “-” and “+” buttons, you can adjust the voltage and clock frequency values of onboard VGA, AGP, PCI and DRAM.

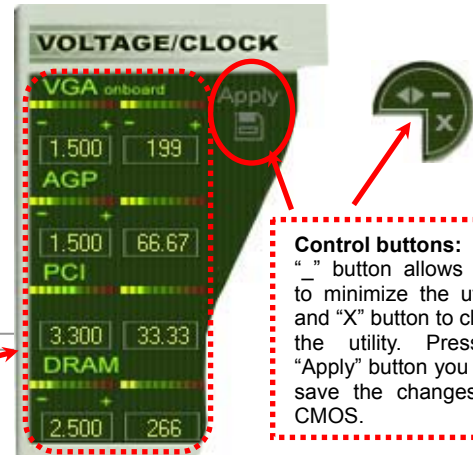

Control buttons:

“-” button allows you to minimize the utility and “X” button to close the utility. Pressing “Apply” button you can save the changes to CMOS.

On the bottom rectangular panel represents CPU fan speed, CPU voltage and CPU temperature. The three color bars on the right hand side will light on according to operation temperature. Please refer to the picture shown above.

CPU Color Bars:

The color bars will light on according to CPU operation temperature.



CPU Fan, Voltage and Temperature:

representing CPU fan speed, CPU voltage and CPU temperature in Celsius and Fahrenheit degrees.

How You Adjust the Settings in BIOS

Apart from EzClock utility, the voltage and frequency values of CPU, PCI and memory can also be adjusted on BIOS page. By pressing

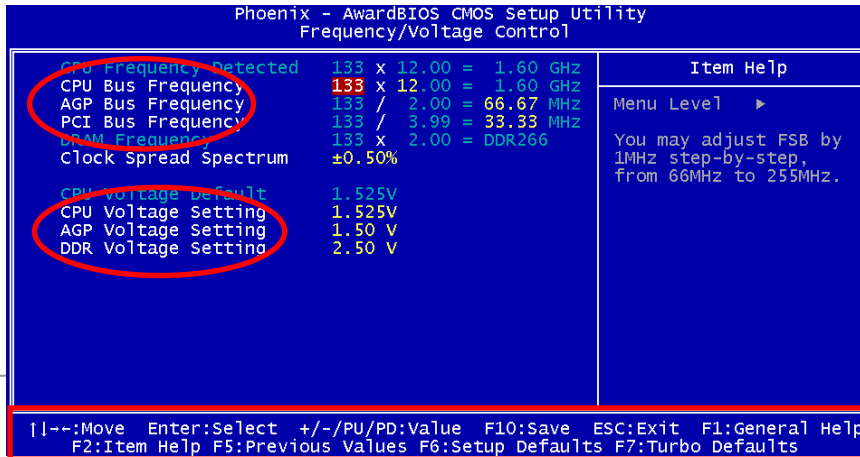

“+”, “-”, “PgUp” or “PgDn” keys, you can adjust the frequency values of CPU Bus, PCI Bus and DRAM.

Also, the same keys help you adjust the voltage of CPU and DDR settings. Some values may change while you adjust the settings. You can press “F10” to save the changes you’ve made.

Function Keys
Description



How Your Boot Screen Looks Like

After you finish setting BIOS, these setting values will be displayed on the boot screen like the shown picture here.

Every time you boot your system, both default and current settings will pop up on the screen. Your personal settings that had been adjusted earlier will be highlighted; thus, you can have clear idea how your system functions and monitor your system more easily.

Current values of your system

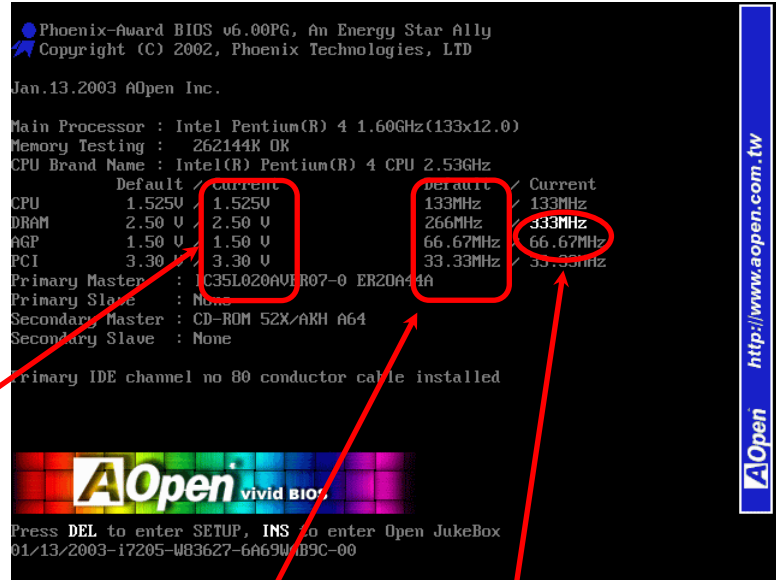

Default settings of this motherboard

The highlighted setting value you manually adjust

AOpen <http://www.aopen.com.tw>

Phoenix-AWARD BIOS

System parameters can be modified by going into [BIOS](#) Setup menu, this menu allows you to configure the system parameters and save the configuration into the 128 bytes CMOS area, (normally in the RTC chip or in the main chipset).

Phoenix-Award BIOS™ installed in the [Flash ROM](#) of the motherboard is a custom version of an industry standard BIOS. The BIOS provides critical low-level support for standard devices such as hard disk drives, serial and parallel ports.

Most BIOS settings of this model have been optimized by AOpen's R&D engineering team. But, the default setting of BIOS still can't fine-tune the chipset controlling entire system. Therefore, the rest of this chapter intends to guide you the process of configuring your system setup.

To enter to BIOS setup menu, press when [POST \(Power-On Self Test\)](#) screen is shown on your monitor.

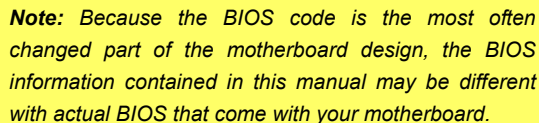

Note: *Because the BIOS code is the most often changed part of the motherboard design, the BIOS information contained in this manual may be different with actual BIOS that come with your motherboard.*

How To Use Phoenix-Award™ BIOS Setup Program

Generally, you can use arrow keys to highlight items that you want to choose, then press <Enter> key to select, and use the <Page Up> and <Page Down> key to change setting values. You can press <Esc> key to quit Phoenix-Award™ BIOS setup program. The following table provides details about how to use keyboard in the Phoenix-Award™ BIOS setup program. Alternatively, it's strongly recommended to install AOpen's newest [WinBIOS](#) Utility to get more detailed description, further powerful functions and advanced setting of BIOS.

Key	Description
Page Up or +	Changing setting to next value or increase the value.
Page Down or -	Changing setting to previous value or decrease value.
Enter	Select the item.
Esc	<ol style="list-style-type: none"> 1. In main menu: Quit and don't save any change. 2. In sub menu: Exit current menu to main menu.
Up Arrow	Highlight previous item.
Down Arrow	Highlight next item.
Left Arrow	Move the light bar to left side of menu.
Right Arrow	Move the light bar to right side of menu.
F6	Load fail-save setting value from CMOS.
F7	Load turbo setting value from CMOS.
F10	Save changed setting and exit setup program.

How To Enter BIOS Setup

After you finish jumper settings and connect correct cables, power on and enter the BIOS Setup. Press during POST (Power-On Self Test) and choose "Load Setup Defaults" for recommended optimal performance.

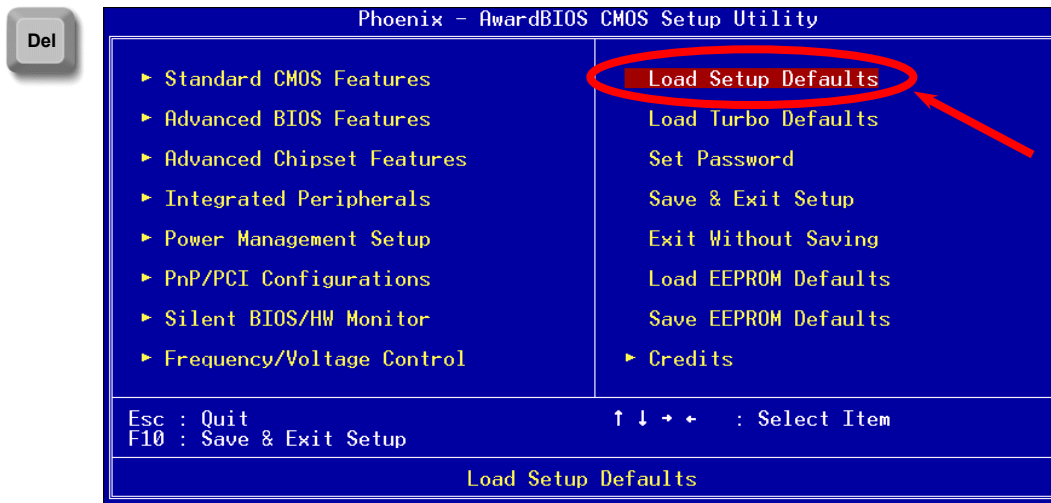

Warning: Please avoid of using "Load Turbo Defaults", unless you are sure your system components (CPU, DRAM, HDD, etc.) are good enough for turbo setting.



BIOS Upgrade under Windows environment



With outstanding R&D ability of AOpen, we now bring you a whole new BIOS Flash wizard ---- EzWinFlash. With an eye to users convenience, EzWinFlash combines the BIOS binary code and flash module together, so the only thing you have to do is just clicking on the utility you downloaded from web and let it helps you complete the flash process automatically. EzWinFlash detects your motherboard and checks the BIOS version cleverly to prevent your system from any possible failure. Moreover, EzWinFlash has been taken into consideration to go with any windows platform you might be using, no matter if you're using Windows 95/98, 98SE/ME, NT4.0/2000, or Windows XP.

In the meanwhile, in order to provide a much more user-friendly operating environment, AOpen EzWinFlash is natively designed to have multi-language function to provide easier way for users' usage in changing BIOS setting.

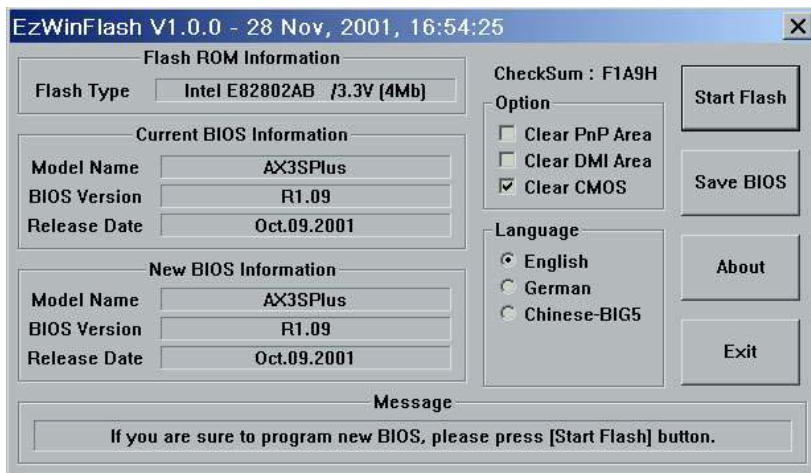

Caution: By updating your motherboard, you are taking a risk of BIOS flash failure. If your motherboard is working stable, and there are no major bugs that had been fixed by a latter BIOS revision, we recommend that you DO NOT try to upgrade your BIOS.

If you intent on upgrading, PLEASE BE SURE to get the right BIOS revision for the right motherboard model to avoid any possibility failure.

You may accomplish BIOS upgrade procedure with EzWinFlash by the following steps, and it's STRONGLY RECOMMENDED to close all the applications before you start the upgrading.

1. Download the new version of BIOS package [zip](http://www.aopen.com) file from AOpen official web site. (ex: <http://www.aopen.com>)
2. Unzip the download BIOS package (ex: WAX45F1394-102.ZIP) with WinZip (<http://www.winzip.com>) in Windows environment.
3. Save the unzipped files into a folder, for example, WAX45F1394-102.EXE & WAX45F1394-102.BIN.
4. Double click on the WAX45F1394-102.EXE; EzWinFlash will detect the model name and BIOS version of your motherboard. If you had got the wrong BIOS, you will not be allowed to proceed with the flash steps.
5. You may select preferred language in the main menu, then click [Start Flash] to start the BIOS upgrade procedure.
6. EzWinFlash will complete all the process automatically, and a dialogue box will pop up to ask you to restart Windows. You may click [YES] to reboot Windows.
7. Press at POST to enter BIOS setup, choose "Load Setup Defaults", then "Save & Exit Setup". Done!

It is strongly recommended NOT to turn off the power or run any application during FLASH PROCESS.



Warning: The new BIOS upgrade will permanently replace your original BIOS's settings when flashing. You may need to reconfigure your BIOS setting so that your system can go back to work as normal.

WinBIOS Utility







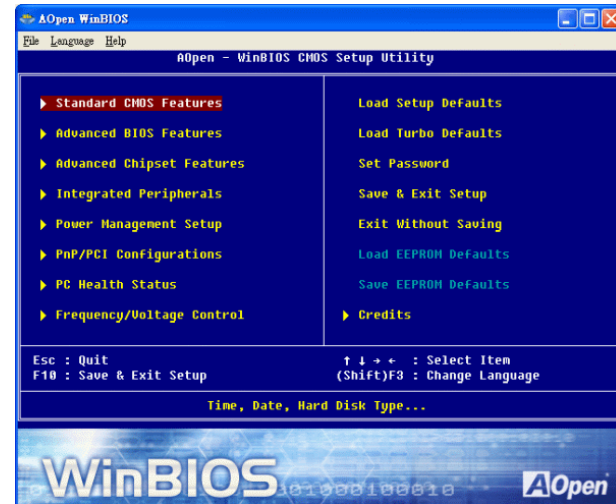

In the past, users have to keep punching the DEL key at a good timing during POST (Power-On-Self-Test) screen to get into the BIOS, which is inconvenient and clumsy. From now on, AOpen provides an easier way to configure your BIOS. WinBIOS is a customized utility for running exclusively on AOpen motherboards, which allows you to setup your BIOS under Windows environment. Designed with traditional-BIOS-alike interface, you may adjust BIOS parameter with clear descriptions for each item.

WinBIOS is natively designed with multi-language support. There are various widely-use languages provided on our website for your downloading, which also helps to prevent wrong settings caused by misunderstanding of the languages. The only thing you have to do is to visit our official website and download your respective language pack (of few KB size), then double-click on it to activate the support with your chosen language.

Moreover, with high scalability, either for newly bought motherboard or the latest BIOS version with new function, you don't have to re-install the whole program again and again. All you have to do is to grab the latest profile from our website, simply double-click on it as well to support the latest version of your BIOS. You don't have to spend any extra effort to have your motherboard supported by WinBIOS.



Function keys:

It's definitely easy to handle WinBIOS as if you're using traditional BIOS setting. Users can use the arrow keys such as     to move around the items in WinBIOS screen. And use  , "+" or "-" to change the setting value if they are available. Press  to get back to the previous screen. Furthermore, the hotkeys shown in the table may help you and save your time. Some settings may not come into effect until you reboot your system.

Caution: After updating your BIOS, please remember to update WinBIOS profile as well. If the upgraded BIOS version is newer than WinBIOS profile, WinBIOS will not be able to launch and a dialog box with error message will pop up. This verification is designed on purpose to protect your BIOS from damaged by wrong profile version.

For the latest WinBIOS profile and language pack modules, you may find them from AOpen official web site as shown below:

<http://english.aopen.com.tw/tech/download/WinBIOS/default.htm>

Note: Due to BIOS versions are updated in an extremely fast speed, it's strongly recommended to download the latest BIOS version and WinBIOS profile from our website upon receipt of the motherboard.

Hotkey	Function Description
F1	Get help description.
F2	Item Help
F3	Changing menu language.
F5	Load previous setting
F6	Load setup default setting
F7	Load turbo setting
F10	Save changed setting and exit setup program.
F12	Full Screen / Normal Mode

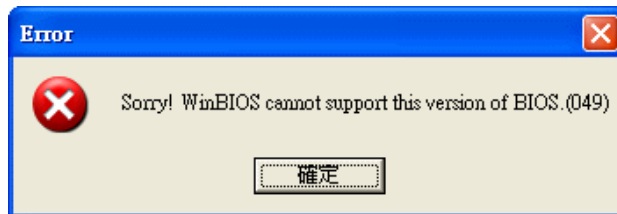

Vivid BIOS technology



Have you been fed up with the conservative and immutable POST screen? Let's rule out the tradition idea that POST screen are stiff and frigid, and let AOpen show you the newly developed VividBIOS to experience the lively vivid colorful POST screen!

Unlike earlier graphic POST screen which could occupy the whole screen and mask text information during POST, AOpen VividBIOS deals with graphics and texts separately, and makes them running simultaneously during POST. With this innovative design, VividBIOS now brings you a beautiful and sleek 256 colors screen without missing any important information shown on POST screen.

In addition, the limited space of BIOS ROM is another big issue. When all of the traditional BIOS can only show space-consuming and uncompressed Bitmap, AOpen has considerably tuned the BIOS to next generation, to recognize the smaller-sized GIF format and even dynamic-showing GIF animation.



Vivid BIOS shares the same fundamental technology with Open JukeBox CD Player, you may use the same EzSkin utility to change your

Vivid BIOS screen or to download your favorite Open JukeBox skin. If you see this little logo  shown beside your model name on the BIOS download page, <http://english.aopen.com.tw/tech/download/skin>, it is assured that your motherboard supports this innovative feature!

Driver and Utility

There are motherboard drivers and utilities in AOpen Bonus CD. You don't need to install all of them to boot your system. But after you finish the hardware installation, you have to install your operation system first (such as Windows XP) before you install any drivers or utilities. Please refer to your operation system's installation guide.

Auto-run Menu from Bonus CD

You can use the auto-run menu of Bonus CD. Choose the utility and driver and select model name.

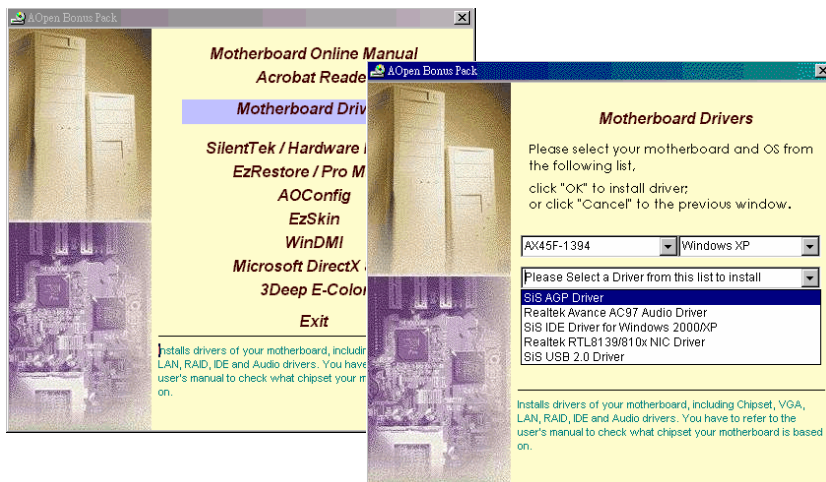

Installing AGP Driver

You can find AGP driver from the Bonus Pack CD auto-run menu.

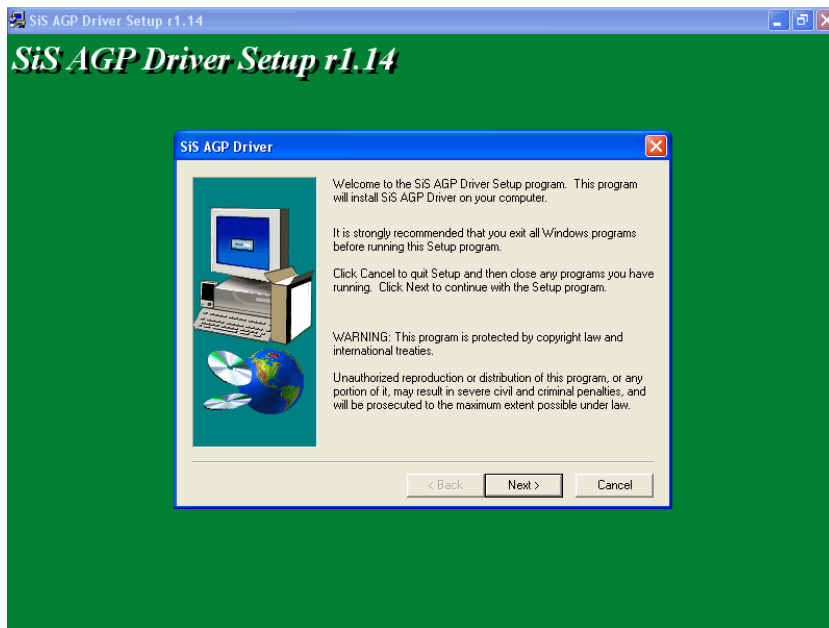

Installing Onboard Sound Driver

This motherboard comes with RealTek ALC650 AC97 CODEC. This audio driver supports Windows 98SE and upper Windows OS; you can find the audio driver from the Bonus Pack CD auto-run menu.

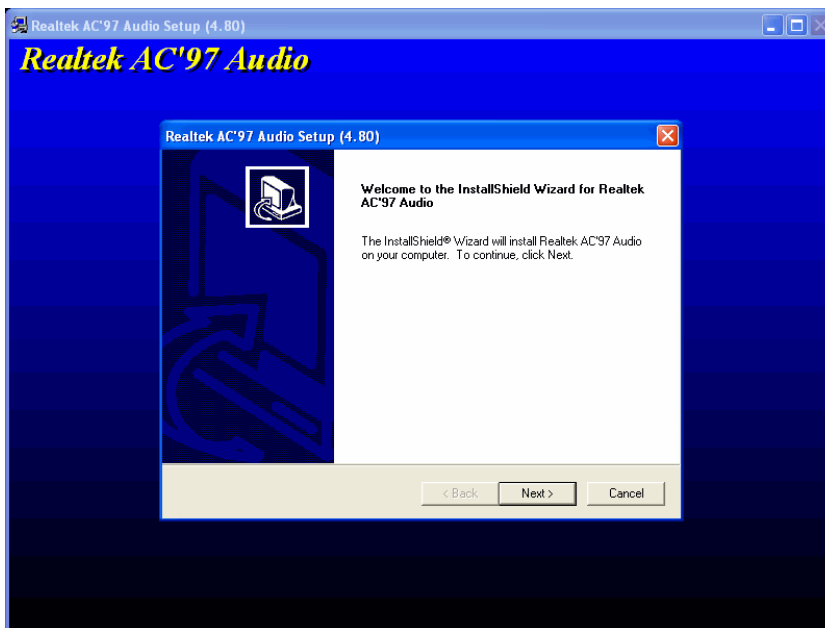

Installing IDE Driver

To use IDE devices you have to install IDE driver from Bonus Pack CD.



Installing LAN Driver

You can find LAN Driver from the Bonus Pack CD and install Realtek RTL8139 PCI Fast Ethernet adapter under Windows 98SE/ME, Windows 2000 and Windows XP system.

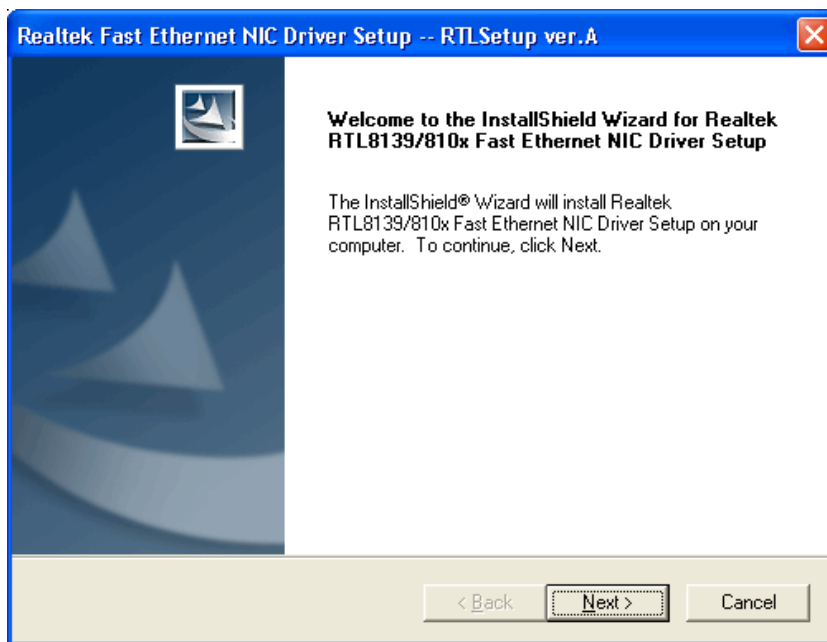

Install Realtek RTL8139 PCI Fast Ethernet adapter under Windows 95 (Golden version), Win95A, OSR2, Windows NT v4.0.

[Windows 95 (Golden version), Win95A and OSR2]

Installing driver procedure on Microsoft Windows 95:

1. Ask you to select which driver you want to install, select "Driver from disk provided by hardware manufacturer".
2. Specify the setup file pathname
[CD-ROM]:\Driver\LAN\RTL8100\Windows\95\WIN95A (for Windows 95 and Win95A) or
[CD-ROM]:\Driver\LAN\RTL8100\Windows\95\W95OSR2 (for Windows 95 OSR2).
3. Windows 95 will appear some messages to insert Windows 95 system disk to complete setup step.
4. Windows 95 will finish the other installation procedure automatically, and then you restart the system.

[Windows NT 3.5, 3.51 & 4.0]

Installing driver procedure on Microsoft Windows NT:

When you are in Windows NT:

1. In the Main group of NT, select the "Control Panel" icon.
2. In the Control Panel window, choose the "Network" icon.

3. In the Network Settings dialog box, choose the "Add Adapter" button. The Add Network Adapter dialog box appears.
4. In the list of network cards, select "<other> requires disk from manufacturer", and then press <Enter> button.
5. Enter drive and pathname
[CD-ROM]:\Driver\LAN\RTL8100\Windows\NT (for NT 4.0) which is the path where the setup files OEMSETUP.INF is located, and then chooses the OK button.
6. The screen will appear "Select Line Speed" dialog box which is provided by RTL8139.SYS driver. The default value is "auto" so that the RTL8139 PCI Fast Ethernet adapter and its driver RTL8139.SYS will auto-detect the line speed, 10 Mb or 100Mb, while the RTL8139.SYS is loading. The other values, "10" or "100", are only used when you want to forced RTL8139 PCI Fast Ethernet adapter to 10Mb or 100Mb.
7. The screen will appear "Input Ethernet ID" dialog box which is provided by RTL8139.SYS driver. This option is only required when you have more than one Realtek RTL8139 PCI Fast Ethernet adapters on this computer. Select "SKIP" if only one adapter is installed on this computer.
8. "Bus Location" display in next screen. Your machine contains more than one hardware bus; please select the Bus Type and Bus number on which your network adapter card is installed.
9. NT will then perform the binding process. If any additional network software options were installed, you may be prompted for specific information for these packages.
10. Restarting your system you will acquire network service.

NOTES:

* Installing Multiple LAN Adapters: Enter Windows NT and follow above setup procedure step 2, in the "Network Settings" dialog box, choose the "Configure..." button. The "Input Ethernet ID" dialog box appears and input adapter's Ethernet ID. Last step is to select OK and close NETWORK SETUP. Select SKIP if only one adapter is installed on this computer.

Installing USB 2.0 Driver

In Bonus Pack CD, you can install USB 2.0 driver from the following screen.



Glossary

AC97 CODEC

Basically, AC97 CODEC is the standard structure of PCI sound card. As we know, computer is digital-based, but music is based on analog-based. Therefore, there must be a process to turn digital into analog during the last stage processing of sound in computer. Hence, the component on sound card that play this important task is what we called CODEC.

Audio CODEC 97 (briefly called AC97) is the specification regulated by Intel, and it's about the structure of audio conversion. The special place about CODEC is that it is separated from sound card (CODEC is an independent chipset). Therefore, PCI sound card could possess with 90db and do other application process as well. We called CODEC that meets this structure AC97 CODEC.

ACPI (Advanced Configuration & Power Interface)

ACPI is the power management specification of PC97 (1997). It intends to save more power by taking full control of power management to operating system and bypass [BIOS](#). The chipset or super I/O chip needs to provide standard register interface to operating system (such as Windows 98). This is a bit similar as the [PnP](#) register interface. ACPI defines ATX momentary soft power switch to control the power state transition.

ACR (Advanced Communication Riser)

Building on the PC motherboard riser architecture, ACR slot is backward compatible with AMR but beyond the limitation of it. The ACR specification is designed to support modem, audio, Local Area Network (LAN) and Digital Subscriber Line (DSL).

AGP (Accelerated Graphic Port)

The main function of AGP simply put is to tell monitor what screen information had to be shown, a visual transmission device actually. With the rapid developing of AGP card, we can see that it had been developed from single colorful AGP card to 2D and 3D graphic. AGP supports only memory read/write operation and single-master single-slave one-to-one only. Though AGP and PCI share the same algorithm of 32-bit, its frequencies are 66MHz and 33MHz respectively. AGP interface had been developed from 2X to 8x.

1X AGP, data transfer rate is $66\text{MHz} \times 4\text{byte} \times 1 = 264\text{MB/s}$

2X AGP, data transfer rate is $66\text{MHz} \times 4\text{byte} \times 2 = 528\text{MB/s}$

4X AGP, data transfer rate is $66\text{MHz} \times 4\text{byte} \times 4 = 1056\text{MB/s}$.

8X AGP, data transfer rate is $66\text{MHz} \times 4\text{byte} \times 8 = 2112\text{MB/s}$.

AMR (Audio/Modem Riser)

The CODEC circuit of AC97 sound/modem solution can be put on motherboard or put on a riser card (AMR card) that connects to motherboard through AMR connector.

ATA (AT Attachment)

Before talking about ATA (AT Attachment), we must understand **DMA** (Direct Memory Access), which allows devices to skip the CPU devices and access memory directly. DMA specification could not only eliminate the workload of CPU, but also accelerate the transmission of data. DMA begins with a data transfer rate of 16.6MB/Sec, but afterward developed to new data rate of 33.3MB/Sec, which is twice the data rate and we called it **Ultra DMA**. **ATA** details power and data signals between the drive and integrated drive controller and the computer's motherboard. Two drives (master and slave) are supported. The ATA specification allows the drive to connect directly to the ISA bus on the computer. ATA transfer rate then had been developed to 133MHz/Sec and would come out with fastest rate later (please refer to [Serial ATA](#)).

DMA, data transfer rate is 16.6MHz/s

Ultra DMA, data transfer rate is 16.6MHz x 2 = 33MB/s.

ATA/66, data transfer rate is 16.6MHz x 4 = 66MB/s.

ATA/100, data transfer rate is 16.6MHz x 6 = 100MB/s.

ATA/133, data transfer rate is 16.6MHz x 8 = 133MB/s.

(ATA/133 uses both rising edge and falling edge as ATA/66 but clock cycle time is reduced to 30ns.)

BIOS (Basic Input/Output System)

BIOS, is a set of assembly routine/program that reside in [EPROM](#) or [Flash ROM](#). BIOS controls Input/output devices and other hardware devices of motherboard. In general, to provide hardware independent portability, operation system and drivers is required to access BIOS without directly access hardware devices.

Bluetooth

Bluetooth is a wireless transferring technology that enables short-range wireless connections between desktop and laptop computers, personal digital assistants (PDAs), cellular phones, printers, scanners, digital cameras and even home appliances. The principle of Bluetooth (a chipset) is to transfer information and voices at the frequency of ISM Band. Every Bluetooth technology devices do come with a standard address for you to connect one-to-one or one-to-seven (to form a Pico-net), with transferring range up to 10 meters (100 meters to follow), using low power radio. Bluetooth do not only possess high transfer rate of 1MB/s, it also could be encrypted with pin code. With hopping rate of 1600 hops per second, it's difficult to be intercepted and are less interrupted by electromagnetic wave.

CNR (Communication and Networking Riser)

The CNR specification provides the PC industry the opportunity to deliver a flexible and cost reduced method of implementing LAN, home networking, DSL, USB, wireless, audio and modem subsystems widely used in today's "connected PCs". The CNR specification is an open industry specification and is supported by OEMs, IHV card manufacturers, silicon supplier and Microsoft.

DDR (Double Data Rate) RAM

DDR RAM utilizes the existing [SDRAM](#) (For ex, PC-100, PC-133) infrastructure and technology while doubling the nominal bandwidth available to systems in an easy to design and simple to adopt way. Based on FSB frequency, DDR RAM on the market are DDR200, DDR266 and DDR333 with more coming around soon.

DDR200, transfer bandwidth up to $200 \times 64 / 8 = 1600 \text{MB/s}$ (PC1600)

DDR266, transfer bandwidth up to $266 \times 64 / 8 = 2100 \text{MB/s}$ (PC2100)

DDR333, transfer bandwidth up to $333 \times 64 / 8 = 2700 \text{MB/s}$ (PC2700)

DDR400, transfer bandwidth up to $400 \times 64 / 8 = 3200 \text{MB/s}$ (PC3200)

ECC (Error Checking and Correction)

The ECC mode needs 8 ECC bits for 64-bit data. Each time memory is accessed; ECC bits are updated and checked by a special algorithm. The ECC algorithm has the ability to detect double-bit error and automatically correct single-bit error while parity mode can only detect single-bit error.

EEPROM (Electronic Erasable Programmable ROM)

Also known as E²PROM. Both EEPROM and [Flash ROM](#) can be re-programmed by electronic signals, but the interface technology is different. Size of EEPROM is much smaller than flash ROM.

EPROM (Erasable Programmable ROM)

Traditional motherboard stores BIOS code in EPROM. EPROM can only be erased by ultra-violet (UV) light. If BIOS has to be upgraded, you need to remove EPROM from motherboard, clear by UV light, re-program, and then insert back.

EV6 Bus

EV6 Bus is the technology of Alpha processor from Digital Equipment Corporation. EV6 bus uses both rising and falling clock edge to transfer data, similar as DDR RAM or ATA/66 IDE bus.

EV6 Bus Speed = CPU external bus clock x 2.

200 MHz EV6 bus, 200MHz = 100 MHz external bus clock x 2

FCC DoC (Declaration of Conformity)

The DoC is component certification standard of FCC EMI regulations. This standard allows DIY component (such as motherboard) to apply DoC label separately without a shielding of housing.

FC-PGA (Flip Chip-Pin Grid Array)

FC means Flip Chip, FC-PGA is a package of Intel for Pentium III for 0.18 μ m process CPU, which can be plugged into SKT370 socket.

FC-PGA2 (Flip Chip-Pin Grid Array)

After FC-PGA, FC-PGA2 is the package for 0.13 μ m process CPU developed by Intel, which can be plugged into SKT423/478 socket as well.

Flash ROM

Flash ROM can be re-programmed by electronic signals. It is easier for BIOS to upgrade by a flash utility, but it is also easier to be infected by virus. Because of increase of new functions, BIOS size is increased from 64KB to 512KB (4M bit).

Hyper Threading

Hyper-Threading technology is an innovative design from Intel that enables multi-threaded software applications to process threads in parallel within each processor resulting in increased utilization of processor execution resources. As a result, an average improvement of ~40% in CPU resource utilization yields higher processing throughput.

IEEE 1394

IEEE 1394, which also called Firewire, is a serial data transfer protocol and interconnection system. The main feature of the Firewire that assures its adoption for the digital video and audio (A/V) consumer application is its low cost. Fire wire interface is capable of supporting various high-end digital A/V applications, such as consumer A/V device control and signal routing, Digital Video (DV) editing, home networking, and more than 32 channels of digital mixing. Gone are those days of expensive video capture cards. Firewire allows for video capture from both newer DV camcorders with Firewire ports and older analog equipment using A/V to Firewire converters.

The advantages of the IEEE1394:

High data transfer rate – Start from 400 Mbps, (with 800/1600/3200 Mbps coming soon), which is about 30 times faster than USB 1.1.

Supports up to 63 devices (16 - daisy chained) with cable length up to about 4.5 m (14 feet).

Hot-pluggable (like USB). No need to turn of your device to connect or disconnect, and you don't need to reboot your PC. Also, it is a plug-and-play bus.

IEEE1394 is very easy to connect (Like USB1.1/2/0).

Parity Bit

The parity mode uses 1 parity bit for each byte, normally it is even parity mode, that is, each time the memory data is updated, parity bit will be adjusted to have even count "1" for each byte. When next time, if memory is read with odd number of "1", the parity error is occurred and this is called single bit error detection.

PCI (Peripheral Component Interface) Bus

Developed by Intel, Peripheral Component Interconnect (PCI) is a local bus standard. A bus is a channel used to transfer data to (input) and from (output) a computer and to or from a peripheral device. Most PCs have a PCI bus usually implemented at 32-bits providing a 33 MHz clock speed with a throughput rate of 133 MBps.

PDF Format

With PDF file, it is easy to do universal document exchange. Virtually any document may be converted in Portable Document Format (PDF). Contents in PDF documents are exactly the same as the original file, including fonts and graphics, and they can be distributed by e-mail or stored on the World Wide Web, an intranet, a file system, or a CD-ROM for other users to view on any platforms. You may download Acrobat Reader in order to read PDF file from its website (www.adobe.com).

PnP (Plug and Play)

Oversimplified, Plug-and-Play automatically tells the software (device drivers) where to find various pieces of hardware (devices) such as modems, network cards, sound cards, etc. Plug-and-Play's task is to match up physical devices with the software (device drivers) that operates them and to establish channels of communication between each physical device and its driver.

POST (Power-On Self Test)

The BIOS self-test procedure after power-on, sometimes, it is the first or the second screen shown on your monitor during system boot.

PSB (Processor System Bus) Clock

PSB Clock means the external bus clock of CPU.

$\text{CPU internal clock} = \text{CPU PSB Clock} \times \text{CPU Clock Ratio}$

RDRAM (Rambus Dynamic Random Access Memory)

A DRAM technology developed by Rambus Corporation*, to achieve high speed of memory through the use of multiple channels in parallel by 16-bits. Basically, RDRAM uses new structure of Multibank, which is quite different from FPM, EDO, SDRAM. Using different memory module as well, RDRAM uses "RIMM" with transfer rate of 600/700/800MHz, providing bandwidth as high to 1.6GB.

RIMM (Rambus Inline Memory Module)

184-pin memory module that supports [RDRAM](#) memory technology. A RIMM memory module may contain up to maximum of 16 RDRAM devices.

SDRAM (Synchronous DRAM)

SDRAM is one of the DRAM technologies that allow DRAM to use the same clock as the CPU host bus (EDO and FPM are asynchronous and do not have clock signal). It is similar as PDSRAM to use burst mode transfer. SDRAM comes in 64-bit 168-pin DIMM and operates at 3.3V, and have been gradually replaced by DDR RAM.

SATA (Serial ATA)

The Serial ATA specification is designed to overcome speed limitations while enabling the storage interface to scale with the growing media rate demands of PC platforms. Serial ATA is to replace parallel [ATA](#) with the compatibility with existing operating systems and drivers, adding performance headroom for years to come. It is developed with data transfer rate of 150 Mbytes/second, and 300M/bs, 600M/bs to come. It reduces voltage and pins count requirements and can be implemented with thin and easy to route cables.

SMBus (System Management Bus)

SMBus is also called I²C bus. It is a two-wire bus developed for component communication (especially for semiconductor IC). For example, set clock of clock generator for jumper-less motherboard. The data transfer rate of SMBus is only 100Kbit/s, it allows one host to communicate with CPU and many masters and slaves to send/receive message.

SPD (Serial Presence Detect)

SPD is a small ROM or [EEPROM](#) device resided on the DIMM or [RIMM](#). SPD stores memory module information such as DRAM timing and chip parameters. SPD can be used by [BIOS](#) to decide best timing for this DIMM or RIMM.

USB 2.0 (Universal Serial Bus)

A Universal Serial Bus (USB) is an external bus (an interconnect) standard that supports data transfer rates of 12 Mbps. A single USB port can be used to connect up to 127 peripheral devices, such as mouse, modems and keyboards. Introduced in 1996, USB has completed replaced serial and parallel ports. It also supports plug-and-play installations and hot plugging Plug-and-play is the ability to add and remove devices to a computer while the computer is running and have the operating system automatically recognize the change. USB 2.0, which supports data transfer rates of 480 Mbps, has been widely used in motherboard these days.

VCM (Virtual Channel Memory)

NEC's Virtual Channel Memory (VCM) is a new DRAM core architecture that dramatically improves the memory system's ability to service multimedia requirements. VCM increases memory bus efficiency and performance of any DRAM technology by providing a set of fast static registers between the memory core and I/O pins. Using VCM technology results in reduced data access latency and reduced power consumption.

Wireless LAN – 802.11b

802.11 is a specification developed by IEEE and Wireless LAN technology, which is an interface between a wireless client and a base station or between two wireless clients.

802.11 families include the following specifications and with more coming:

802.11 = 1 or 2 Mbps transmission in the 2.4 GHz band, using either frequency hopping spread spectrum (FHSS) or direct sequence spread spectrum (DSSS).

802.11a = 54 Mbps in the 5GHz band, using orthogonal frequency division multiplexing)

802.11b (11 Mbps transmission in the 2.4 GHz band, using direct sequence spread spectrum (DSSS).

ZIP file

A compressed file format to reduce file size. To unzip file, run shareware PKUNZIP (<http://www.pkware.com/>) for DOS and other operating system or WINZIP (<http://www.winzip.com/>) for windows environment.



Troubleshooting

If you encounter any trouble to boot your system, follow the procedures accordingly to resolve the problem.

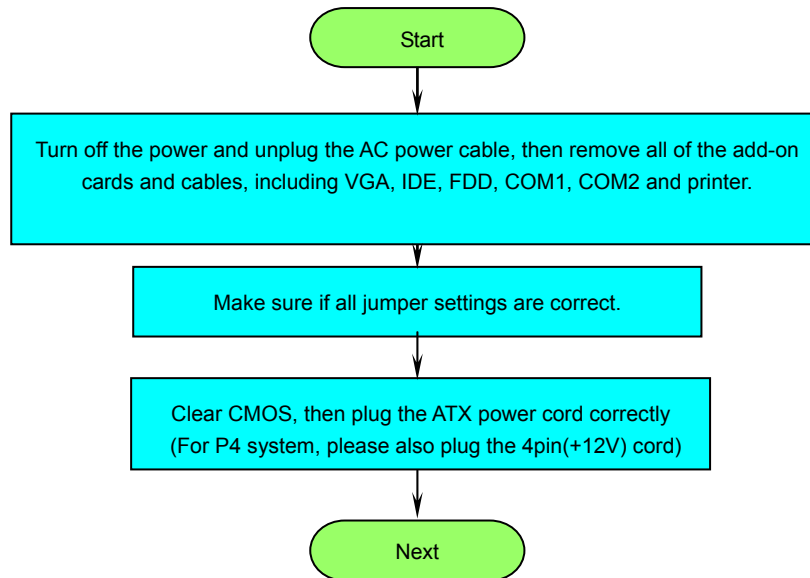

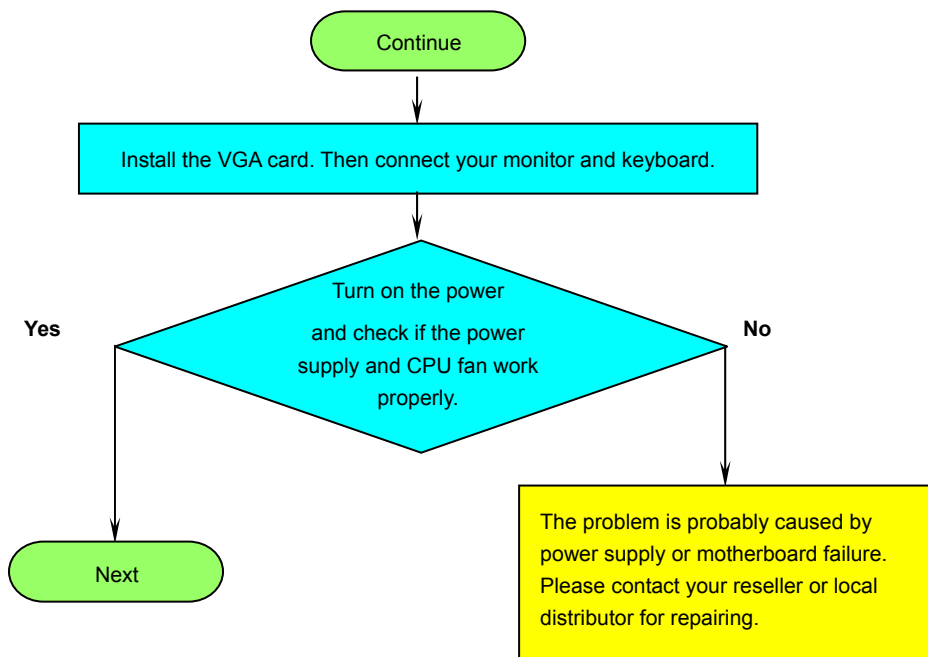

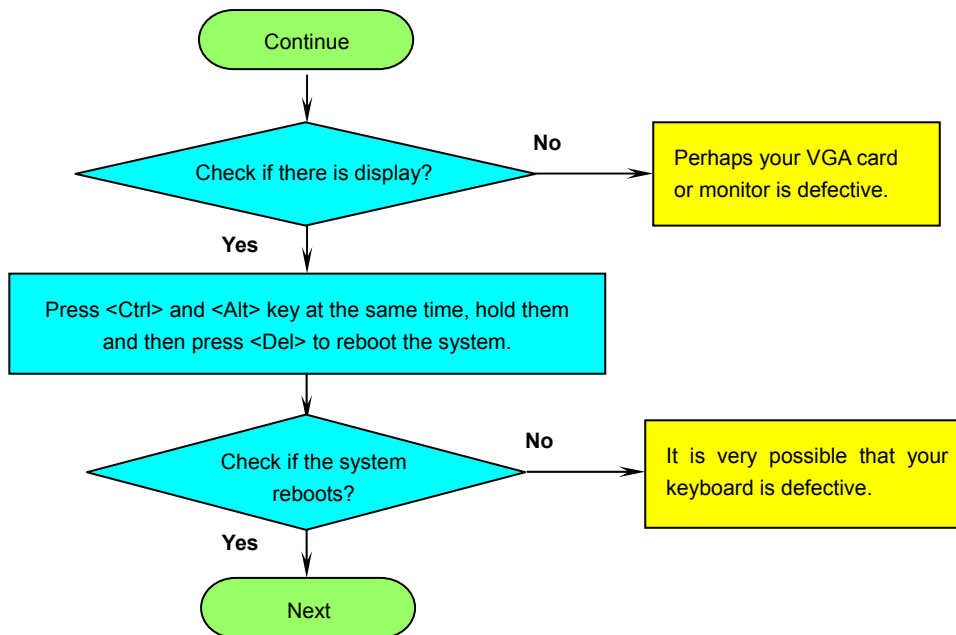

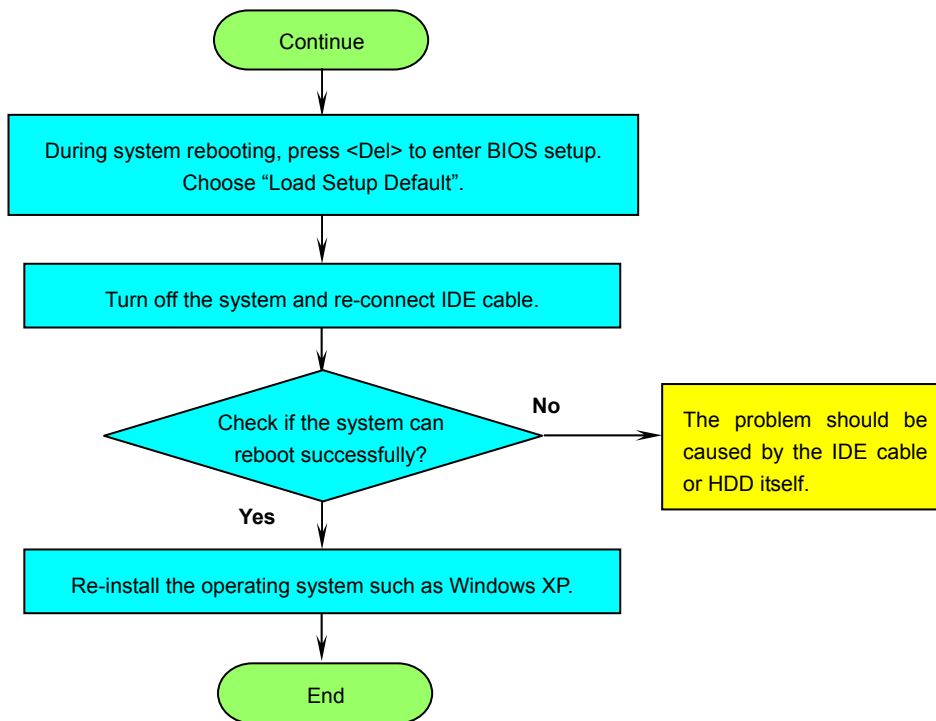



Technical Support

Dear Customer,

Thanks for choosing AOpen products. To provide the best and fastest service to our customer is our first priority. However, we receive numerous emails and phone-calls worldwide everyday, it is very hard for us to serve everyone on time. We recommend you follow the procedures below and seek help before contact us. With your help, we can then continue to provide the best quality service to more customers.

Thanks very much for your understanding!

AOpen Technical Supporting Team

1

Online Manual: To download manual, please log on and then select your preferred language. Under “Type” directory, choose “Manuals” to go to our manual database. You can also find the manual and EIG in AOpen Bonus Pack.

<http://download.aopen.com.tw/downloads>

2

Test Report: We recommend you to choose board/card/device from the compatibility test reports for assembling your PC. It may prevent incompatibility problems.

<http://english.aopen.com.tw/tech/report/default.htm>

3

FAQ: Here we list problems that users often encounter and FAQ (Frequently Asked Questions). You may be able to find a solution to your problem.

<http://club.aopen.com.tw/faq/>

4

Download Software: After log on and having language selected, you may get the latest updated BIOS/utility and drivers you need under “Type” directory. In most case, newer versions of drivers and BIOS have solved earlier bugs or compatibility problems.

<http://download.aopen.com.tw/downloads>



5

eForum: AOpen eForum is provided to discuss our products with other users, in which your problem probably had been discussed before or will be answered. After log on, you may select your preferred language under "Multi-language".

<http://club.aopen.com.tw/forum/>

6

Contact Distributors/Resellers: We sell our products through resellers and integrators. They should know your system configuration very well and should be able to solve your problem efficiently and provide important reference for you.

7

Contact Us: Please prepare detail system configuration and error symptom before contacting us. The **part number**, **serial number** and **BIOS version** are also very helpful.

Part Number and Serial Number

The Part Number and Serial number are printed on bar code label. You can find this bar code label on the outside packing, or on component side of PCB. For example:

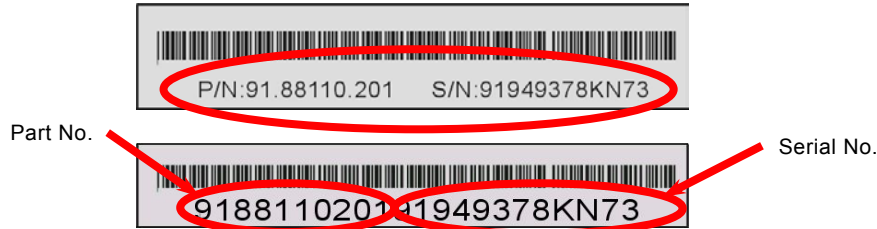

P/N: 91.88110.201 is part number, **S/N: 91949378KN73** is serial number.

Model name and BIOS version

Model name and BIOS version can be found on upper left corner of first boot screen ([POST](#) screen). For example:



AX45F-1394 R1.00 Jun. 1. 2003 AOpen Inc.

Phoenix-Award Plug and Play BIOS Extension v1.0A

Copyright © 2003, Award Software, Inc.

AX45F-1394 is model name of motherboard, **R1.00** is BIOS version.



Product Registration

ClubAOpen

Welcome to AOpen Inc.



Thank you for choosing AOpen product. AOpen encourages you to spend few minutes in completing the following product registration. To register your product will ensure the high quality of services from AOpen. After the registration, you will:

- Have opportunities to play online slot machine and win a prize from AOpen by accumulating your bonuses for later prize exchange.
- Be upgraded to gold membership of Club AOpen program.
- Receive email notification about product safety alerts. Its purpose is to alert consumers quickly and conveniently when products contain technical issues.
- Receive email notification about latest product's announcements.
- Be able to personalize your AOpen web pages.
- Receive e-mail notification about latest BIOS/Driver/Software release information.
- Have opportunities to participate special product promotional programs.
- Enjoy higher service priority to receive technical assistance provided by AOpen specialists worldwide.
- Be able to join the discussions of web-based news groups.

AOpen makes sure that the information you provide is encrypted, so that it cannot be read or intercepted by other people or companies. Further, AOpen will not disclose any of information you submitted under any conditions. Please consult our [online privacy policy](#) for further information on our company policy.

Note: *If registering products purchased from different dealers/retails and/or purchased on different dates, please submit a separate form for each product.*



How to Contact Us



Please do not hesitate contact us if you have any problem about our products. Any opinion will be appreciated.

<p>Pacific Rim AOpen Inc. Tel: 886-2-3789-5888 Fax: 886-2-3789-5899</p>	<p>Europe AOpen Computer b.v. Tel: 31-73-645-9516 Email: support@aopen.nl</p>	<p>America AOpen America Inc. Tel: 1-510-498-8928 Fax: 1-408-922-2935</p>
<p>China 艾爾鵬國際貿易(上海)有限公司 Tel: 86-21-6225-8622 Fax: 86-21-6225-7926</p>	<p>Germany AOpen Computer GmbH. Tel: 49-2102-157700 Fax: 49-2102-157799</p>	<p>Japan AOpen Japan Inc. Tel: 81-048-290-1800 Fax: 81-048-290-1820</p>

Web Site: <http://www.aopen.com.tw>

E-mail: Send us email by going through the contact form below.

English <http://english.aopen.com.tw/tech/default.htm>

Japanese <http://www.aopen.co.jp/tech/default.htm>

Chinese <http://www.aopen.com.tw/tech/default.htm>

German <http://www.aopencom.de/tech/default.htm>

Simplified Chinese <http://www.aopen.com.cn/tech/default.htm>